



*Center Drain Shower Base

Specification Features

- DREAMSTONE BASE AND WALL KIT
- DURABLE SOLID SURFACE MATERIAL IS EASY TO CLEAN
- WHITE COLOR RUNS COMPLETELY THROUGH THE MATERIAL
- NEO-ANGLE (2-WALL CORNER)
- SLIP-RESISTANT PEBBLE PATTERN PROVIDES ADDITIONAL SAFETY
- RESISTS MOLD AND MILDEW
- TRIM-TO-SIZE WALL PANELS CAN BE CUT ON-SITE

Technical Information

- Model: DreamStone
- Shower Base Type: Neo-Angle (2-Wall Corner)
- Dimensions: 38" D x 38" W x 84" H
- Product Width: 38"
- Product Depth: 38"
- Product Height: 84"
- Base Color: White
- Backwalls Color: White
- Backwalls Patern: Traditional Subway Pattern

Shower Base Finish Options

- White

Model SKU#:

BWDS38383TC0001

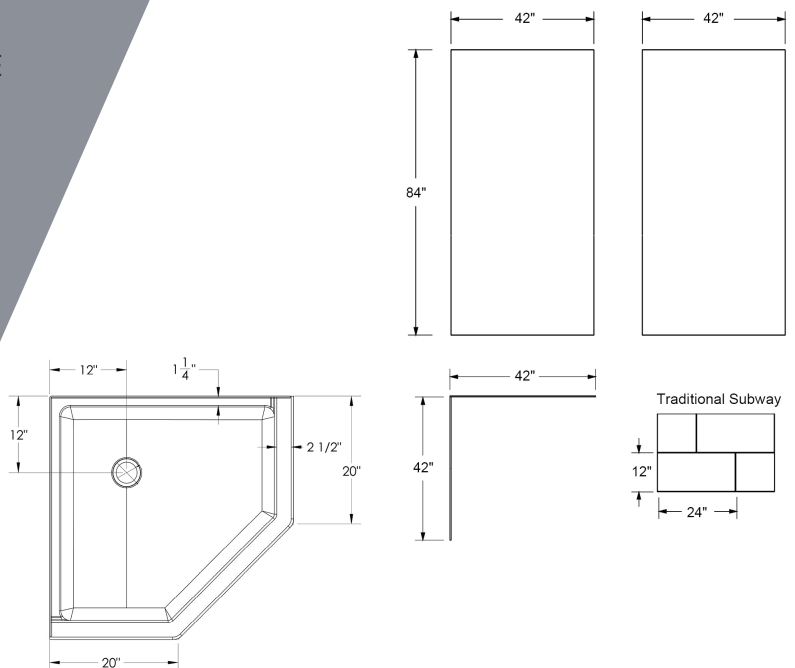

Product Details

Important Notes



Base Corner

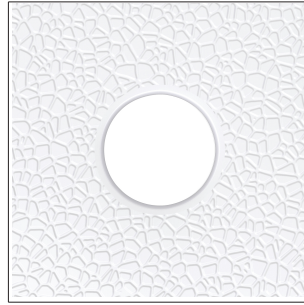

Base Drain

DreamStone authentic solid surface shower bases feature an easy-to-clean, non-porous surface that resists mold and mildew.

The solid color runs completely throughout the material for long-lasting durability and easy maintenance.

Please read Installation Manual thoroughly prior to installing this product.

Base Installation: Direct to studs (Unfinished walls: Prior to backerboard, cement board, etc.).

Wall Installation: Glue on solid surface, such as wonderboard or greenboard (not directly to studs).

Professional installation is required.

Important Disclaimers

Please note that you should consult your local building codes with questions on installation compliance standards. Building and plumbing codes may vary by location, and DreamLine® is not responsible for code compliance standards for your project and will not accept any returns.

For commercial customers, we strongly recommend the use of Dreamline's Onsite Contractor Support option.

Dreamline's commercial warranty does not apply to damage or losses resulting from (i) other than normal and proper use and normal service conditions; (ii) improper installation, (iii) installation in or upon an unsuitable surface or areas; (iv) abuse, (v) accident, (vi) alteration, (vii) misuse, (viii) neglect, (ix) unauthorized repair or the failure to utilize suitably qualified and trained persons to perform service and/or repair of the Product, (x) improper maintenance, (xi) failure to follow installation, operating, cleaning or maintenance instructions, and (xii) use of "non-authorized" parts.