

Commercial Grade Classic Crossback Swivel Bar Height Wooden Stool



ASSEMBLY INSTRUCTIONS

Before You Begin: Phillips Screwdriver is required (Not Included).

Please identify all component parts and hardware pieces required before you begin. Carefully remove all of the components from the packaging and set aside for assembly. Assemble on a soft surface to prevent scratching during assembly.

Caution:

Tighten all components securely before use. Failure to do so may result in personal injury.

DO NOT use any sharp objects to open plastic wrapped components as damage to product or components may result.

Warning:

CHOKING HAZARD - Small Parts. Adult Assembly Required.

DO NOT ALLOW CHILDREN TO CLIMB ON FURNITURE

Serious or fatal injuries can occur from furniture tipping over. You must install Tipping Restraint Hardware (where included) to help prevent the unit from tipping and causing accidental injury, instability, death or damage. The tipping restraint is intended only as a safety measure, it is not a substitute for proper adult supervision.

To help prevent furniture from tipping over it must be permanently attached to the wall. Anti-Tip Safety Wall Straps suitable for the unit weight and wall materials (if not included) should be purchased and installed.

Have a Question/Concern?

Quality products and first-class customer service are the cornerstone of long-lasting consumer relationships. We strive toward excellence in all we do and want you to be completely satisfied with your purchase.

Please contact our exceptional Customer Experience Agents at the email address or phone number shown below to assist you with any product questions or issues before requesting a return.

We look forward to serving you in a friendly, efficient manner to resolve any issues you may have.

Customer Service Email: CustomerExperience@belnick.com

Customer Service Phone: 866-552-2810

Our Warranty Statement

This warranty covers manufacturing defects associated with your new product. The product is warranted from the original purchase date and to the original purchaser for normal usage, according to the below-referenced specifications and limitations.

- Non-moving metal parts are warranted for 5 years.
- Component parts including pneumatic cylinder, control mechanism, base and casters are warranted for 2 years.
- All other items are warranted for 1 year.

Normal usage means use in compliance with the restrictions and weight limits specified for the product. In the absence of product-specific restrictions and weight limits, normal usage means use for no more than forty hours per week by persons weighing 250 lbs. or less. Coverage terminates if the product is sold or otherwise transferred. Repairs made by parties other than Belnick also void this warranty.



This warranty will not cover: (1) labor, freight, or damage from misuse, abuse, negligence, alteration, assembly, installation, attachments, accident, vandalism, acts of nature or any other event beyond the control of Belnick; (2) tearing, scratching, scuffing, or blemishing of leather or fabric; (3) cosmetic damage that may result from normal usage; (4) damage attributable to use by persons exceeding specified weight limits or commercial use exceeding forty hours per week; or (5) rust or other damage caused by exposure to moisture. The user assumes all risk of injury resulting from use of this product. Liability for incidental or consequential damage is excluded. Some states do not allow the exclusion or limitation of incidental or consequential damages, so the above limitation or exclusion may not apply to you.





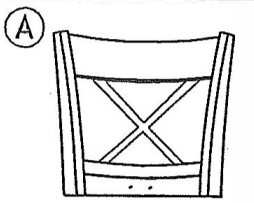
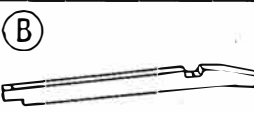
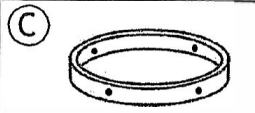

.....

ASSEMBLY INSTRUCTION

IMPORTANT NOTE:

- To prevent scratches, place all wooden parts on a clean, smooth surface such as carpet.
- Keep all hardware parts out of reach of children.
- Follow step by step assembly instructions.

PARTS LIST	
	Backrest 1 PC
	Chair Leg 4 PCS
	Footrest 1 PC
	Apron with Swivel Plate 1 PC
	Cushion seat 1 PC

HARDWARE LIST		
ITEM	DESCRIPTION	QTY
1	Hex Screw M6 x 25MM 	4 PCS
2	Hex Screw M6 x 40MM 	14 PCS
3	Hex Screw M6 x 90MM 	4 PCS
4	Lock Washer M6 x 13MM 	18 PCS
5	Flat Washer 6.5mm x 16.5mm 	10 PCS
6	Flat Washer M6 x 13mm 	12 PCS
7	Allen Wrench M4 	1 PC

NOTE : Do not tighten all the screws until the stool is fully assembled.

STEP 1

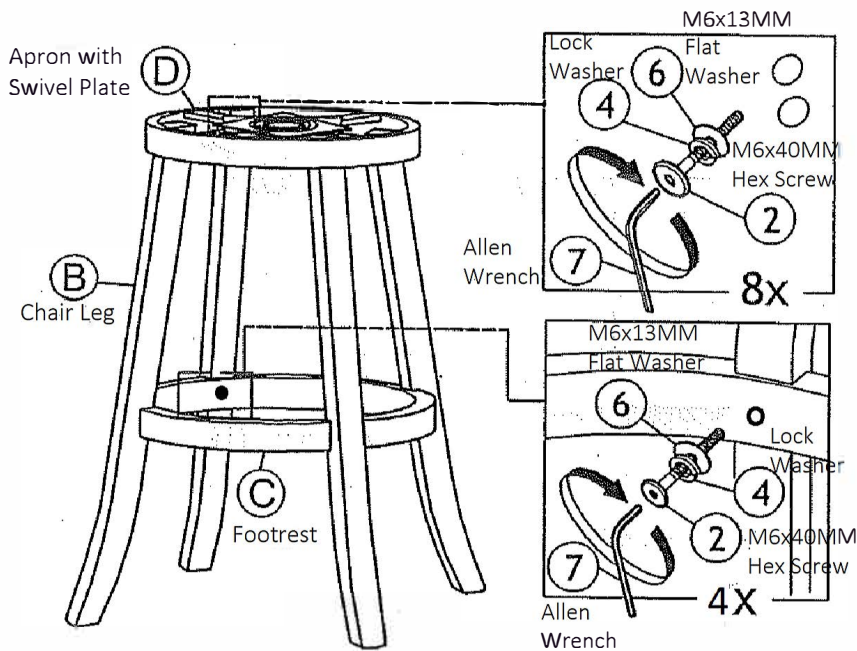

Attach the Chair Legs (Part B) to the Apron with Swivel Plate (Part D), then attach the Footrest (Part C) to inside of the Chair Legs (Part B) using (12) M6x40mm Hex Screws (Part 2), (12) Lock Washers (Part 4) and (12) M6x13mm Flat Washers (Part 6). Loosely tighten using Allen Wrench (Part 7).

ASSEMBLY INSTRUCTION

STEP 2

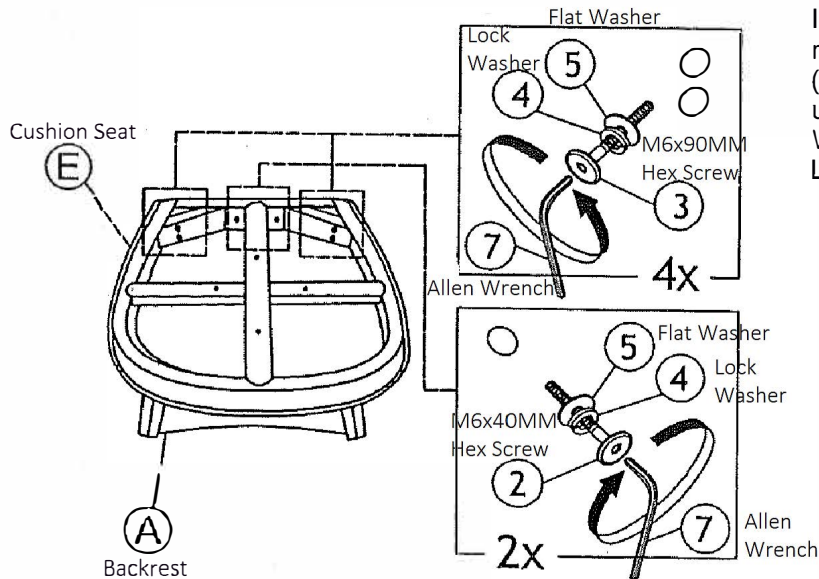

Invert Cushioned Seat (Part E) and place on a stable raised surface such as a table. Attach the Backrest (Part A) to the corners of the Cushioned Seat (Part E) using (4) M6x90MM Hex Screws (Part 3), (4) Lock Washers (Part 4), and (4) Flat Washers (Part 5). Loosely tighten using Allen Wrench (Part 7).

Finish attaching the Backrest (Part A) to the Cushioned Seat (Part E) using (2) M6x40MM Hex Screws (Part 2), (2) Lock Washers (Part 4) and (2) Flat Washers (Part 5). Loosely tighten using Allen Wrench (Part 7).

STEP 3

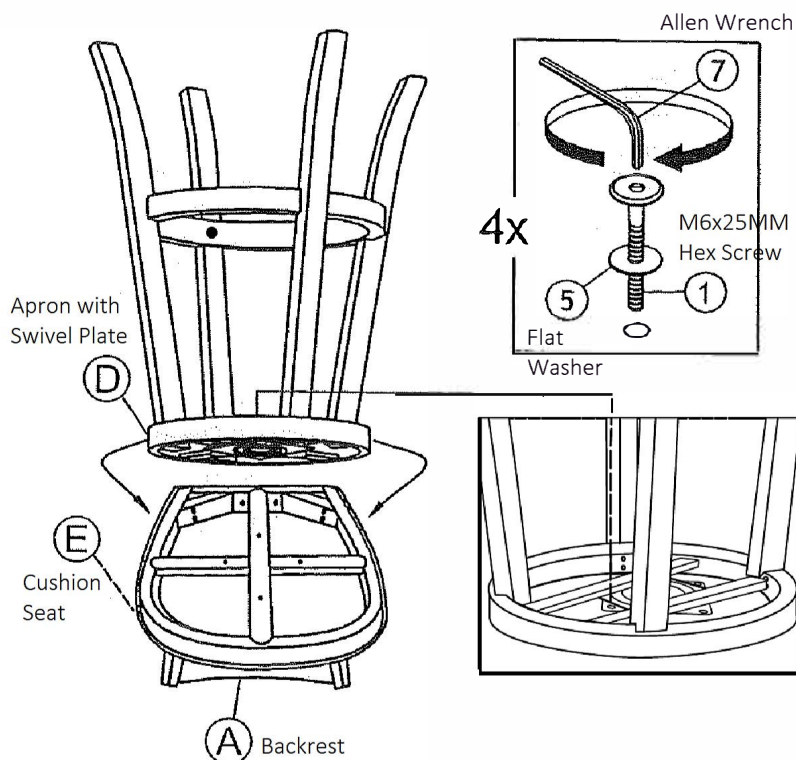

Keep the Backrest (Part A) and Cushioned Seat (Part E) inverted on a stable raised surface. Attach the Swivel Plate located on the Apron with Swivel Plate (Part D) to the Cushioned Seat (Part E) using (4) M6x25mm Hex Screws (Part 1) and (4) 6.5x16.5mm Flat Washers (Part 5). Return Chair to the upright position and securely tighten all screws using Allen Wrench (Part 6).

ENSURE THAT ALL SCREWS ARE FULLY TIGHTENED BEFORE USE.