



ZGARD S & DS Gas Sensors

Instruction Manual

⚠ WARNING

THIS MANUAL MUST BE CAREFULLY READ BY ALL INDIVIDUALS WHO HAVE OR WILL HAVE THE RESPONSIBILITY FOR USING OR SERVICING THE PRODUCT. Like any piece of complex equipment, this instrument will perform as designed only if it is used and serviced in accordance with the manufacturer's instructions. OTHERWISE, IT COULD FAIL TO PERFORM AS DESIGNED AND PERSONS WHO RELY ON THIS PRODUCT FOR THEIR SAFETY COULD SUSTAIN SEVERE PERSONAL INJURY OR DEATH.

The warranties made by Mine Safety Appliances Company with respect to the product are voided if the product is not used and serviced in accordance with the instructions in this manual. Please protect yourself and others by following them. We encourage our customers to write or call regarding this equipment prior to use or for any additional information relative to use or service.

Manuel d'instructions

⚠ Détecteur d'Émanations

Veillez lire attentivement les instructions qui suivent. Tous ceux qui sont responsables, ou qui auront la responsabilité pour l'installation, la fonctionnalité ou l'usage de ce produit doivent se familiariser complètement avec ses instructions. Comme tout appareil complexifié, ce produit peut vous donner les résultats anticipés seulement s'il est installé, usagé et que le service d'entretien sont effectués d'après les instructions du fabricant (ou manufacturier). Sous peine de ne pas suivre les instructions ci-incluses, il est possible que cet appareil vous donne des résultats insuffisant. En conséquence, les personnes qui dépendront sur ce produit pour leur sécurité peuvent être blessés ou mourir.

Les garanties de 'Mine Safety Appliances Company' par rapport à ces produits sont annulés si les produits ne sont pas installés, usagés et le service maintenus conformément aux instructions ci-incluses. Veuillez vous protéger ainsi que les autres, en suivant les instructions d'installations. S'il vous plaît, entrez en communications avec nous au sujet de ce produit avant l'utilisation de ce produit ou pour plus amples renseignements, sois pour l'usage ou les réparations.

In North America., to contact your nearest stocking location, dial toll-free 1-800-MSA-INST
To contact MSA International, dial (724) 776-8626

© MINE SAFETY APPLIANCES COMPANY 2014 - All Rights Reserved

This manual is available on the internet at www.MSAafety.com

Manufactured by

MSA NORTH AMERICA

1000 Cranberry Woods Drive, Cranberry Township, PA 16066

MSA Permanent Instrument Warranty

1. **Warranty** - Seller warrants that this product will be free from mechanical defect or faulty workmanship for a period of eighteen (18) months from date of shipment or one (1) year from installation, whichever occurs first, provided it is maintained and used in accordance with Seller's instructions and / or recommendations. This warranty does not apply to expendable or consumable parts whose normal life expectancy is less than one (1) year such as, but not limited to, non-rechargeable batteries, filament units, filter, lamps, fuses etc. The Seller shall be released from all obligations under this warranty in the event repairs or modifications are made by persons other than its own or authorized service personnel or if the warranty claim results from physical abuse or misuse of the product. No agent, employee or representative of the Seller has any authority to bind the Seller to any affirmation, representation or warranty concerning the product. Seller makes no warranty concerning components or accessories not manufactured by the Seller, but will pass on to the Purchaser all warranties of manufacturers of such components. **THIS WARRANTY IS ON LIEU OF ALL OTHER WARRANTIES, EXPRESSED, IMPLIED OR STATUTORY, AND IS STRICTLY LIMITED TO THE TERMS HEREOF. SELLER SPECIFICALLY DISCLAIMS ANY WARRANTY OF MERCHANTABILITY OR OF FITNESS FOR A PARTICULAR PURPOSE.**
2. **Exclusive Remedy** - It is expressly agreed that Purchaser's sole and exclusive remedy for breach of the above warranty, for any tortious conduct of Seller, or for any other cause of action, shall be the repair and / or replacement at Seller's option, of any equipment or parts thereof, which after examination by Seller is proven to be defective. Replacement equipment and /or parts will be provided at no cost to Purchaser, F.O.B. Seller's Plant. Failure of Seller to successfully repair any nonconforming product shall not cause the remedy established hereby to fail of its essential purpose.
3. **Exclusion of Consequential Damage** - Purchaser specifically understands and agrees that under no circumstances will Seller be liable to Purchaser for economic, special, incidental or consequential damages or losses of any kind whatsoever, including but not limited to, loss of anticipated profits and any other loss caused by reason of nonoperation of the goods. This exclusion is applicable to claims for breach of warranty, tortious conduct or any other cause of action against seller.

General Warnings

⚠ WARNING

1. The ZGARD S & DS gas sensors described in this manual must be installed, operated, and maintained in strict accordance with the labels, cautions, warnings, instructions, and within the limitations stated.
2. The ZGARD S & DS gas sensors must not be installed in outdoor areas or in locations where explosive concentrations of combustible gases or vapors might occur in the atmosphere: Class 1, Group A, B, C, and D areas as defined by the NEC. Because the gas sensors are not explosion-proof, they must be located in non-hazardous areas. The ZGARD S & DS gas sensor must not be subject to direct sunlight or equivalent.
3. Do not paint the ZGARD S & DS gas sensors. Cleaning must be with warm water only (no cleaning solutions).
4. The only absolute method to assure the proper overall operation of a gas detection instrument is to check it with a known concentration of the gas for which it has been calibrated. Consequently, a calibration check must be included as part of the installation and as a routine inspection of the system.
5. Use only genuine MSA replacement parts when performing any maintenance procedures provided in this manual. Failure to do so may seriously impair instrument performance. Repair or alteration of the ZGARD S & DS gas sensors, beyond the scope of these maintenance instructions or by anyone other than authorized MSA service personnel, could cause the product to fail to perform as designed, and persons who rely on this product for their safety could sustain serious personal injury or death.
6. The ZGARD S & DS gas sensors must be installed, located and operated in accordance to all applicable codes. These codes include, but are not limited to, the National Fire Prevention Code and National Electric Code.
7. Do not exceed the relay contact ratings listed in this manual. Otherwise, the relay operation may fail, which can result in personal injury or death.

FAILURE TO COMPLY WITH THE ABOVE WARNINGS CAN RESULT ON SERIOUS PERSONAL INJURY OR DEATH.

⚠ AVERTISSEMENTS

1. Le détecteur d'émanations ZGARD S & DS tel que représenté dans ce manuel doit être installé, opéré et maintenu conformément aux étiquettes, les cautions, avertissements, ainsi que les instructions et les restrictions spécifiées.
2. Le détecteur d'émanations ZGARD S & DS ne doit pas être fixé en plein air ou dans une région où des concentrations explosives de gaz ou de vapeur sont présentes dans l'atmosphère; Classe 1, Groupes A, B, C, et D comme définis par le NEC. Étant donné que les détecteurs d'émanations ne sont pas protégés contre les explosions, ils devraient être localisés dans un endroit non-dangereux. Le détecteur d'émanation ZGARD S & DS ne doit pas être exposé au soleil.
3. Veuillez ne pas peindre le ZGARD S & DS. Nettoyer uniquement avec de l'eau tiède, sans savon ou produits de nettoyage.
4. Pour vérifier que l'appareil fonctionne bien, il s'agit de l'exposer à une concentration d'émanation pour laquelle l'appareil a été calibré. Conséquemment, une vérification du calibre doit être incluse comme partie de l'installation ainsi qu'à l'inspection régulière du système.
5. Un mot de caution lors de l'entretien de cet appareil; il est nécessaire d'utiliser que les pièces MSA lors d'effectuer l'entretien de cet appareil. Sinon, l'appareil peut faillir. Toutes réparations ou modifications du détecteur d'émanations au dessus des instructions ci-incluses, ou par autre personne non-autorisée par le MSA peut causer une faillite mettant en danger les personnes qui dépendent sur cet appareil pour leur bien-être contre les blessures et la mortalité.
6. Le détecteur d'émanations ZGARD S & DS doit être fixé, localisé, et opéré conformément aux codes applicables. Ces codes sont inclus, mais pas limités au 'National Fire Prevention Code' et le 'National Electric Code.'
7. Ne pas dépasser l'indique du relais tel que spécifié dans ce manuel d'instructions. Autrement, l'opération du relais peut faire faillite qui, par la suite peut causer des blessures physiques ou même la mortalité.

CAUTION: Si vous n'adhérez pas aux avertissements ci-haut spécif

Table of Contents

Chapter 1,	
General Information and Applications	1-1
Table 1-1. ZGARD S & DS Sensors	1-1
Chapter 2,	
Installation Guidelines	2-1
Mounting	2-1
Wiring Connections	2-1
▲ WARNING	2-1
▲ CAUTION	2-1
Chapter 3,	
Start-Up	3-1
Operating Features and Setup ZGARD S Sensors (4 to 20 mA and RS-485)	3-1
Table 3-1. ZGARD S & DS Sensor Specifications	3-1
ZGARD S Sensors (RS-485 Only)	3-2
Bump Test	3-2
Table 3-2. Digital Binary Address Codes	3-3
Chapter 4,	
Calibration	4-1
Calibration Procedure	4-1
▲ WARNING	4-1
Calibration Equipment	4-1
▲ WARNING	4-1
Calibration Of ZGARD S & DS Sensors	4-1
Zero Calibration	4-1
Span Calibration	4-1
Sensor Out of Range or Inoperative After Calibration	4-2
Sensor Fail Indication	4-2
Chapter 5,	
Parts List	5-1
Table 5-1. Parts List	5-1
▲ WARNING	5-1
Appendix A,	
Installation Outline Drawings	A-1

Chapter 1, General Information and Applications

The ZGARD S Sensors are designed to detect the presence of Carbon Monoxide, Nitrogen Dioxide and Combustibles in air.

The ZGARD DS is a Dual Sensor in one enclosure designed to detect the presence of Carbon Monoxide and Nitrogen Dioxide in air. Depending on the type of sensor used, electrochemical, solid-state metal oxide or catalytic bead technology is employed. Each generates a representative output signal proportional to the calibrated operating range.

The ZGARD S & DS sensors are available with two output versions, a 4-20mA analog output or an addressable RS485 digital signal. The ZGARD S & DS, RS485 version is specifically designed to

operate with any MSA ZGARD C 485 or CXII Controller, operating as a system. The ZGARD S & DS with 4-20mA output can be installed as a stand-alone sensor typically integrated with common commercial equipment including PLC, DCS or Building Environmental Automation Systems or operate with any ZGARD C Controller.

TABLE 1-1 shows distinctive features of the ZGARD S & DS Sensors and is a quick guide for determining the operating features of each sensor. The performance of any ZGARD S & DS Sensor depends on the appropriate and strategic placement within a guarded area. Gas sensors should be strategically placed closest to the areas where the target gases or vapors might occur in the atmosphere.

Table 1-1. ZGARD S & DS Sensors

	CARBON MONOXIDE (SS)	CARBON MONOXIDE (EC)	NITROGEN DIOXIDE (EC)	COMBUSTIBLE (LEL)
Principal of Operation	MOS, Metal Oxide Semiconductor	Electrochemical	Electrochemical	Catalytic Sensor
Accuracy at STP	+/- 10% Full Scale	+/- 5% Full Scale	+/- 10% Full Scale	+/- 5% Full Scale
Operating Range	0-100 ppm OR 0-200 ppm	0-100 ppm OR 0-200 ppm	0-10 ppm	0-100% LEL
Zero Deadband	17 ppm	1 ppm	0.1 ppm	1% LEL
Output	4-20mA OR RS485 Network	4-20mA OR RS485 Network	4-20mA OR RS485 Network	4-20mA OR RS485 Network
Operating Temperature	0° to 40°C	-20° to 40°C	0° to 40°C	-20° to 40°C
Storage Temperature	-10° to 50°C	-20° to 50°C	-10° to 50°C	-20° to 50°C
Humidity	25 to 95% RH	0 to 95% RH	0 to 95% RH	0 to 95% RH
Altitude	0 to 6562 Feet / 0-2000 Meter			
SENSOR ENCLOSURE				
ZGARD S Enclosure	Powder-coated metal double-gang connection box			
Dimensions	5.5" H (140 mm) x 5.5" W (140 mm) x 2.2" D (56 mm)			
Weight	0.45kg (1.00 lbs.)			
ZGARD DS Enclosure	Polycarbonate			
Dimensions	7.0" H (178 mm) x 10.5" W (267 mm) x 4.5" D (114 mm)			
Weight	1.1kg (2.45 lbs.)			

Chapter 2, Installation Guidelines

NOTE: Reference the Installation Outline drawings in this manual, Appendix A.

Mounting

- Do not mount the sensor to structures subject to vibration and shock, such as piping and piping supports.
- Do not locate the sensor near an excessive heat source or in wet or damp locations.
- For proper cooling, allow at least five inches of clearance around all surfaces except for the mounting surface. Also consider mounting the sensor so it can be easily accessed for service and routine testing.
- The sensor has four mounting lugs; securely mount the instrument to a wall or support using appropriate hardware.

Wiring Connections

Before putting a ZGARD S & DS Sensor into operation, determine the elevation and the number of gas sensors according to the required application. Also refer to the ZGARD S & DS sensor(s) Installation Outline drawings for important information regarding:

- Operating power
- Required conductors and wire size
- 4-20 mA and RS485 Network wiring connection.

⚠ WARNING

When wiring the sensor, disconnect the main power to prevent bodily harm.

⚠ ATTENTION!

Lors de l'installation électrique du détecteur, couper le courant d'électricité du détecteur en entier pour éviter toutes possibilités de chocs qui peut causer des blessures corporelles.

⚠ CAUTION

Do not use the sensor power when connecting any external devices.

Use shielded cable for wiring installation. Do not install low voltage signal cable in the same conduit as the other

devices such as sensors operating power and or relay wiring.

Make sure that each RS485 sensor is given a unique address (Switch selected) to enable the MSA ZGARD C series controller to communicate properly.

When connecting sensors, make sure all wiring is correct for the power and signal leads. Ensure the RS485 bus wiring is not interchanged; otherwise, permanent sensor damage may result.

Perform all wiring and conduit installation in accordance with the National Electrical Code.

Failure to follow the above Warning and Cautions can result in injury or property damage.

⚠ CAUTION

Utilisez pas le pouvoir électrique du détecteur pour brancher autres appareils.

Se servir uniquement le fil conducteur électrique ayant un écran de protection. Soyez avisé qu'il faut isoler un conduit uniquement pour l'électricité (pouvoir) du détecteur ainsi que le relais.

Assurez-vous que chaque détecteur a son propre bouton de contrôle pour assurer que le contrôleur du MSA ZGARD S & DS communique directement tel que branché.

Lorsque vous branchez le détecteur isolé, assurez-vous que le branchage de fils électriques sont convenable au pouvoir (électricité). Veuillez noter que le fil RS 485 ne doit pas être échangé pour un autre fil électrique, il est unique à cet appareil. Autrement, vous courez le risque d'endommager, en permanence, le détecteur.

Exécuter tout branchement et installation de conduit conformément au "National Electric Code".

A coup sûr, si les cautions ci-haut mentionnés ne sont pas suivis, il y a possibilité de blessures corporelles et vous courez chance d'endommager votre propriété.

Chapter 3, Start-Up

- The ZGARD S and DS Sensors are factory-calibrated and ready for immediate use.
- Once power is applied to the unit and a 30-second delay occurs, the normal green LED is solid ON to indicate the sensor is operating properly.

Table 3-1. ZGARD S & DS Sensor Specifications

Operating Power	mA	24 VAC/DC 50/60 Hz Class 2 Source	250 mA max Comb 100 mA max SS 100 mA max EC
	RS485	24 VDC Class 2 Source	250 mA max Comb 100 mA max SS 100 mA max EC
	RS485-PR	24 VDC/DC 50/60 Hz Class 2 Source	250 mA max Comb 100 mA max SS 100 mA max EC
Signal	mA	Isolated 4-20 mA current source	
	RS485	2-wire (plus shield) network connection	
	RS485-PR	2-wire (plus shield) network connection	

Operating Features and Setup ZGARD S Sensors (4 to 20 mA and RS-485)

SW2	
→←	1 TEST FULL SCALE (100% OUTPUT)
→←	2 TEST HALF SCALE (50% OUTPUT)
→←	3 TEST ZERO SCALE (0% OUTPUT)
→←	4 CUT-OFF (ON/ OFF)

ZGARD S Sensors, Output Test: Each sensor provides a means of driving the output to 0%, 50% or 100% full-scale. Respectively, when the onboard switch SW2 is turned ON to 1 or 2 or 3, the sensor generates the selected output signal. This feature is useful for testing remote devices, which may be connected to the sensor output.

SW2	
→←	1 TEST FULL SCALE (100% OUTPUT)
→←	2 TEST HALF SCALE (50% OUTPUT)
→←	3 TEST ZERO SCALE (0% OUTPUT)
→←	4 CUT-OFF (ON/ OFF)

ZGARD S Sensors, Zero Deadband: Each sensor provides a zero deadband (cut-off) option to eliminate possible high background interference of any unsuspected environmental or other airborne compounds. This function is switch-enabled. When SW2, position 4 is in the OFF position, the zero deadband feature is enabled. When SW2, position 4 is in the ON position, there is no deadband.

ZGARD S Sensors (RS-485 Only)

SW2	
→←	1 TEST FULL SCALE (100% OUTPUT)
→←	2 TEST HALF SCALE (50% OUTPUT)
→←	3 TEST ZERO SCALE (0% OUTPUT)
→←	4 CUT-OFF (ON/ OFF)
→←	5 NOT USED
→←	6 NOT USED
→←	7 PRIBUSIN
→←	8 NOT USED

SW1	RS-485 ADDRESS 1 - 127 (SET BY BINARY)
1 →←	1
2 →←	2
4 →←	3
8 →←	4
16 →←	5
32 →←	6
64 →←	7

For RS-485 Sensors, SW2 - position 7 must always be turned ON. This will allow the sensor to communicate to a C 485, CX or CXII controller.

Digital Address Binary Code Setup: Each sensor must be given a unique address code for accurate communication. The binary address code is set by arranging the user selection switch SW1 as shown. Turning on SW1 switches 1, 2, 3, 4, 5, 6 and 7 according to the appropriate Binary Address Code required for each application. **See TABLE 3-2 for details.**

Bump Test

Apply a representative sample gas to the sensor and check if the sensor responds to the target gas and has reached the appropriate value.

NOTE: Any connected remote equipment may be activated.

The initial sensor function test is now completed.

TABLE 3-2 is a representation of the appropriate selection of SW1 Switches 1 through 7 for the first 40 sensor addresses. Note that address '0' is invalid.

Table 3-2. Digital Binary Address Codes

BINARY ADDRESS	1 SW1-1	2 SW1-2	4 SW1-3	8 SW1-4	16 SW1-5	32 SW1-6	64 SW1-7
1	ON	OFF	OFF	OFF	OFF	OFF	OFF
2	OFF	ON	OFF	OFF	OFF	OFF	OFF
3	ON	ON	OFF	OFF	OFF	OFF	OFF
4	OFF	OFF	ON	OFF	OFF	OFF	OFF
5	ON	OFF	ON	OFF	OFF	OFF	OFF
6	OFF	ON	ON	OFF	OFF	OFF	OFF
7	ON	ON	ON	OFF	OFF	OFF	OFF
8	OFF	OFF	OFF	ON	OFF	OFF	OFF
9	ON	OFF	OFF	ON	OFF	OFF	OFF
10	OFF	ON	OFF	ON	OFF	OFF	OFF
11	ON	ON	OFF	ON	OFF	OFF	OFF
12	OFF	OFF	ON	ON	OFF	OFF	OFF
13	ON	OFF	ON	ON	OFF	OFF	OFF
14	OFF	ON	ON	ON	OFF	OFF	OFF
15	ON	ON	ON	ON	OFF	OFF	OFF
16	OFF	OFF	OFF	OFF	ON	OFF	OFF
17	ON	OFF	OFF	OFF	ON	OFF	OFF
18	OFF	ON	OFF	OFF	ON	OFF	OFF
19	ON	ON	OFF	OFF	ON	OFF	OFF
20	OFF	OFF	ON	OFF	ON	OFF	OFF
21	ON	OFF	ON	OFF	ON	OFF	OFF
22	OFF	ON	ON	OFF	ON	OFF	OFF
23	ON	ON	ON	OFF	ON	OFF	OFF
24	OFF	OFF	OFF	ON	ON	OFF	OFF
25	ON	OFF	OFF	ON	ON	OFF	OFF
26	OFF	ON	OFF	ON	ON	OFF	OFF
27	ON	ON	OFF	ON	ON	OFF	OFF
28	OFF	OFF	ON	ON	ON	OFF	OFF
29	ON	OFF	ON	ON	ON	OFF	OFF
30	OFF	ON	ON	ON	ON	OFF	OFF
31	ON	ON	ON	ON	ON	OFF	OFF
32	OFF	OFF	OFF	OFF	OFF	ON	OFF
33	ON	OFF	OFF	OFF	OFF	ON	OFF
34	OFF	ON	OFF	OFF	OFF	ON	OFF
35	ON	ON	OFF	OFF	OFF	ON	OFF
36	OFF	OFF	ON	OFF	OFF	ON	OFF
37	ON	OFF	ON	OFF	OFF	ON	OFF
38	OFF	ON	ON	OFF	OFF	ON	OFF
39	ON	ON	ON	OFF	OFF	ON	OFF
40	OFF	OFF	OFF	ON	OFF	ON	OFF

Chapter 4, Calibration

Calibration Procedure

While the ZGARD S & DS sensors are factory-calibrated, the user must perform regular calibration checks as part of a routine inspection and maintenance schedule. Use calibration gases of known and certified concentrations, and check the expiration date on the gas cylinders.

⚠ WARNING

The calibration procedure must be completed after the replacement of sensing cells; otherwise the unit could fail to perform as designed and persons who rely on this product for their safety could sustain severe personal injury or death.

⚠ ATTENTION!

Le procès de calibration doit être complété lors du remplacement de cellules du détecteur. Sinon, l'appareil peut faire faillite qui augmente la possibilité de causer des blessures corporels ou la mortalité.

Calibration Equipment

- Flow controller 0.25 liters/minute and tubing
- Zero Gas and Span Gas

SENSOR TYPE	SPAN VALUE	MSA GAS CYLINDER PART. NO.
Carbon Monoxide	60 ppm CO	710882
Nitrogen Dioxide	5 ppm NO ₂	710332
Combustible	2.5% CH ₄	10028032
Zero Air	20.8% O ₂ in Nitrogen	10028042

- Calibration magnet (MSA P/N 30060-2)
- Calibration cover (MSA P/N 10128624) for S sensor
- Calibration cover (MSA P/N 10149017) for DS sensor

⚠ WARNING

Remove the Calibration Cover after calibration is complete; otherwise, the unit could fail to perform as designed and persons who rely on this product for their safety could sustain severe personal injury or death.

⚠ ATTENTION!

Enlever le couvercle du calibre seulement une fois le procès de calibration est terminé. Autrement, vous courez chance de faillite de l'appareil et les gens qui se fient sur cet appareil pour leurs sécurité cours une chance de blessures corporelles ou même la mortalité.

Calibration Of ZGARD S & DS Sensors

NOTE: Slow Flash = 1 Flash per second
Fast Flash = 8 Flashes per second.

Zero Calibration

1. Apply Zero Air to sensor using calibration cover.
2. Apply magnet to calibration target until the Green LED slow flashes; then, **remove** magnet.
3. Remove Zero Air when green LED is SOLID ON (stops flashing)

NOTE: If the previous Span Calibration failed, the red LED SLOW FLASH appears instead of the green SOLID ON LED.
Proceed to Span Calibration.

4. Zero calibration is now complete (time required is two minutes); proceed to Span Calibration.

Span Calibration

1. Apply Span Gas to sensor using calibration cover.
2. Apply magnet to calibration target until the Green LED fast flashes; then, remove magnet.

NOTE: Green LED slow flashes first.

NOTE: mA output is held at 4 during calibration.

3. Remove the Span Gas when the Green LED is Solid ON.
4. Span calibration is now complete (time required is two minutes).
 - There is a two-minute delay when the Green LED stays ON.

5. Remove calibration cover.

NOTE: Upon completion of span calibration, there is a two-minute delay before sensor output returns. This time allows for the span gas to dissipate, preventing false indications from the controller.

- If magnet is left on for more than 16 seconds, calibration aborts and normal operation resumes (with no change to calibration).
- When calibrating a solid state CO sensor, nafion tubing (MSA P/N 813628) should be installed between the regulator and calibration cover.

Sensor Out of Range or Inoperative After Calibration

- If Sensor is out of range or inoperative after calibration, the Red LED slow flashes.
- Perform a new Zero and Span calibration to resolve the problem.

Sensor Fail Indication

- If a sensor fails or is not present, the Red LED turns ON and the sensor is not seen by the controller. (SENSOR FAIL)

Chapter 5, Parts List

Table 5-1. Parts List

ITEM	PART NUMBER
Replacement Electrochemical (EC) CO Cell Assembly	10064004
Replacement Electrochemical (EC) NO2 Cell Assembly	10064003
Replacement Solid-State (SS) CO Cell Assembly	10063828
Replacement LEL Cell Assembly	10143928
Calibration Cover for S Sensor	10128624
Calibration Cover for DS Sensor	10149017
Calibration Magnet	30060-2

NOTE: When ordering replacement parts, please state the unit's MSA Part Number and Serial Number.

⚠ WARNING

Use only genuine MSA replacement parts when performing any maintenance on the ZGARD S & DS Sensors. Failure to do so may seriously impair instrument performance. Repair or alteration of the ZGARD S & DS gas sensors, beyond the scope of these maintenance instructions or by anyone other than authorized MSA service personnel, could cause the product to fail to perform as designed, and persons who rely on this product for their safety could sustain serious personal injury or death.

Disconnect all power source(s) to the ZGARD S & DS Sensors before removing or changing components.

⚠ ATTENTION!

Un mot de caution lors de l'entretien du détecteur ZGARD S & DS. Il est nécessaire d'utiliser que les pièces MSA lors d'effectuer l'entretien. Sinon, vous pouvez causer l'appareil de ne pas fonctionner proprement. Toutes réparations ou modifications du détecteur ZGARD S & DS au dessus des instructions ci-inclues ou par autre personne non-autorisée par le MSA peut causer une faillite de l'appareil mettant en danger les personnes qui dépendent sur cet appareil pour leur bien-être contre les blessures et la mortalité.

Coupez tout pouvoir (électricité) au détecteur ZGARD S & DS avant d'effectuer des changements, modifications ou réparations.

Appendix A, Installation Outline Drawings

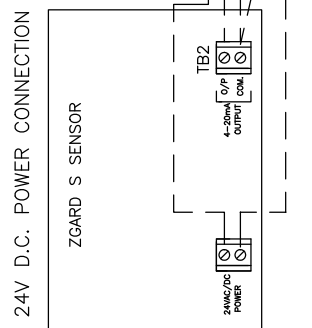
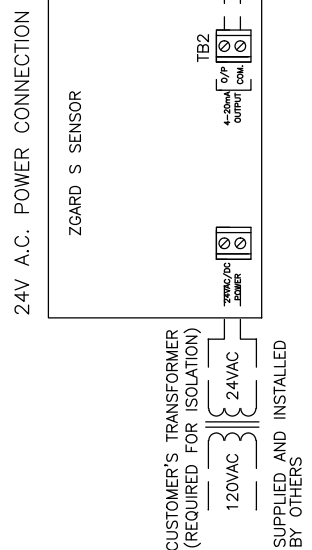
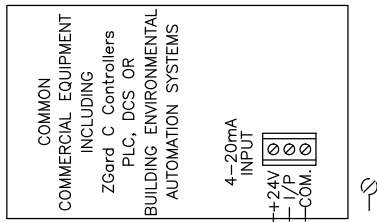
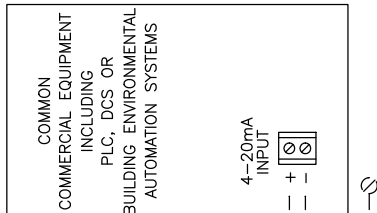

OR

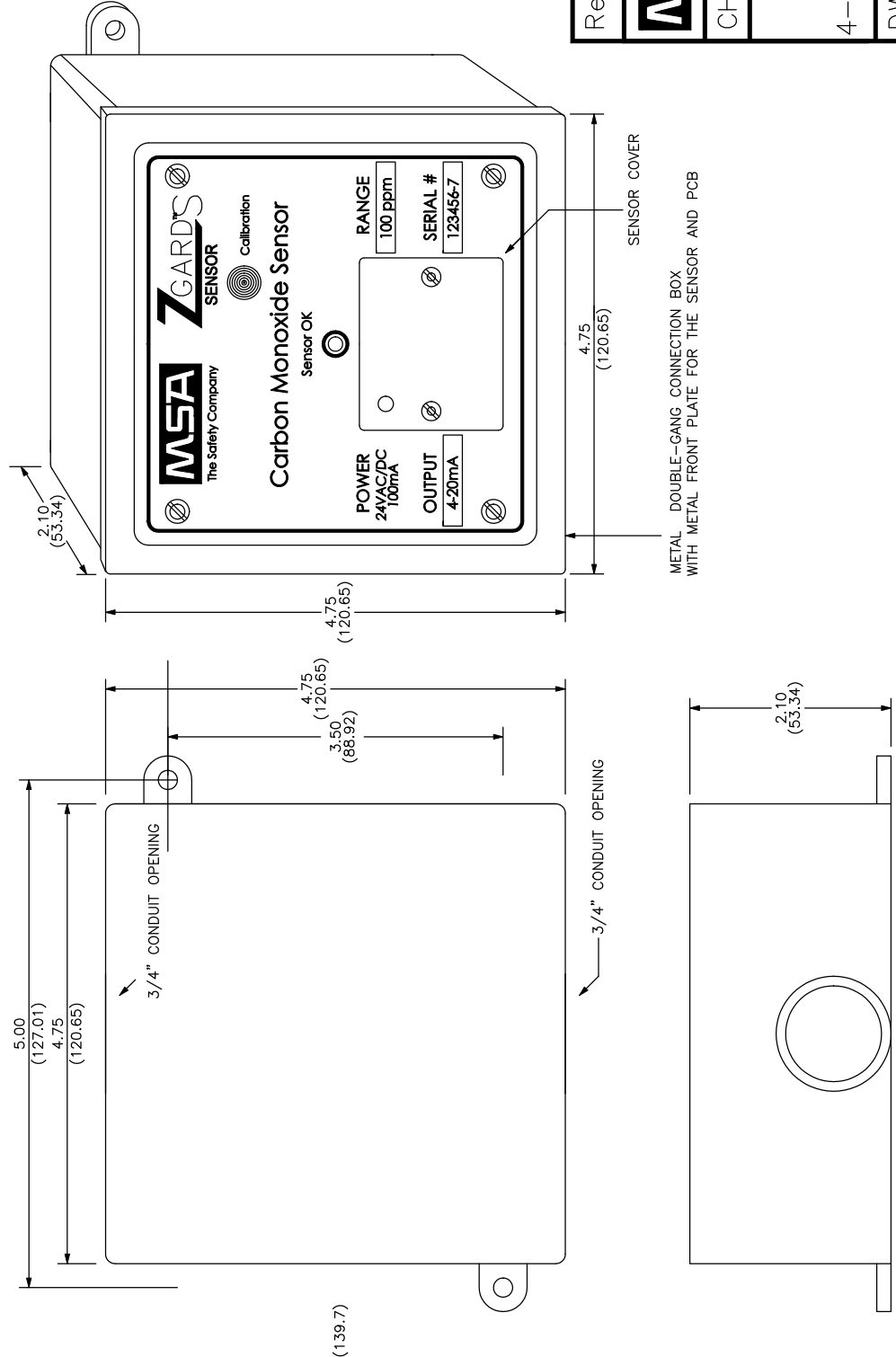

CABLE LENGTH VS. SIZE (AWG#)

CABLE LENGTH FEET	GAUGE (AWG#)
1 TO 5,000	18

SUGGESTED CABLE

GAUGE (AWG#)	3-WIRE SHIELDED CABLE	2-WIRE SHIELDED CABLE
18	ALPHA WIRE 5523	ALPHA WIRE 5522

NOTES:
1. DIMENSIONS SHOWN IN INCHES (MILLIMETERS).

(139.7)

Rev. C ZGARD MAG CAL VERSION

MSA

CHKD: V.E DATE: Nov. 16/04 DRN: KS

Installation Outline,
ZGARD S,
4-20mA Output Stand-Alone Sensors

DWG. NO.: 106897 REV. D

FOR DAISSY-CHAIN (SERIES) WIRING OF ZGARD S SENSORS TO AN MSA ZGARD C SERIES CONTROLLER AS SHOWN HERE, EACH SENSOR MUST BE UNIQUELY ADDRESSED VIA JUMPERS ON SENSOR CIRCUIT BOARD.

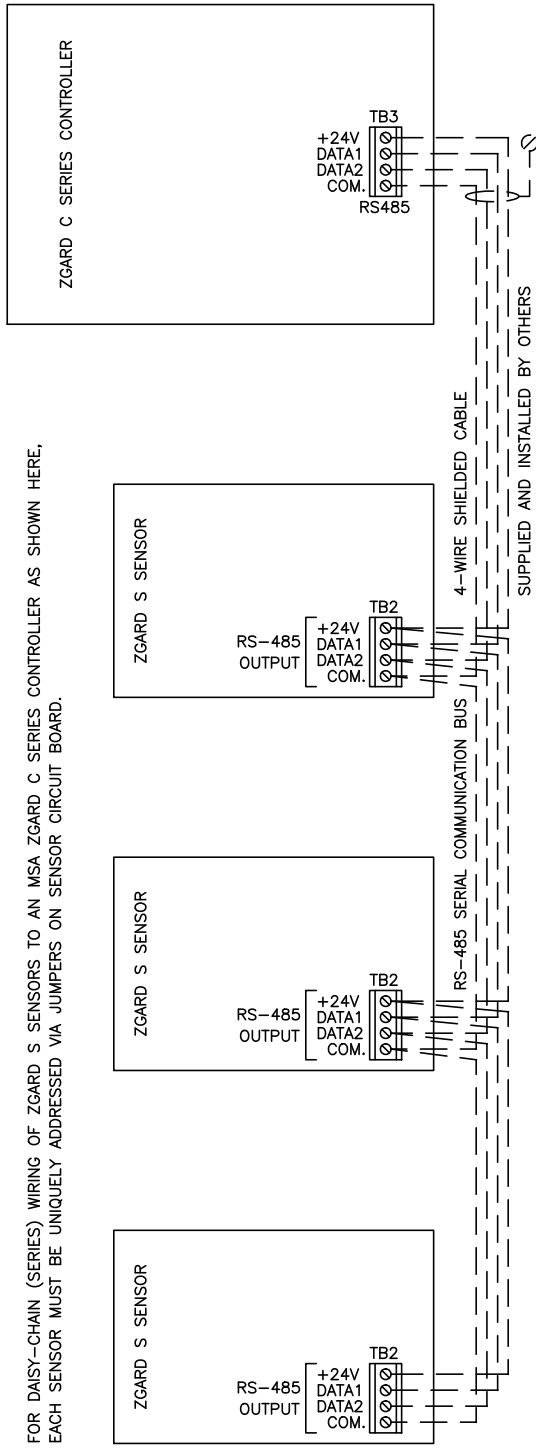

CABLE LENGTH VS. SIZE (AWG#)

CABLE LENGTH FEET	No. OF SENSORS	4	6	8	10	12	14	16
1 TO 500	AWG #	22	22	22	22	22	20	20
501 TO 1,000	AWG #	22	20	20	20	18	18	18
1,001 TO 1,500	AWG #	20	18	18	16	16	16	16
1,501 TO 2000	AWG #	18	16	16	14	14	14	14

SUGGESTED CABLE	
GAUGE (AWG#)	4-WIRE SHIELDED CABLE
22	ALPHA WIRE 5504
20	ALPHA WIRE 5514
18	ALPHA WIRE 5524
16	ALPHA WIRE 5534
14	ALPHA WIRE 5544

NOTES:
1. DIMENSIONS SHOWN IN INCHES (MILLIMETERS).

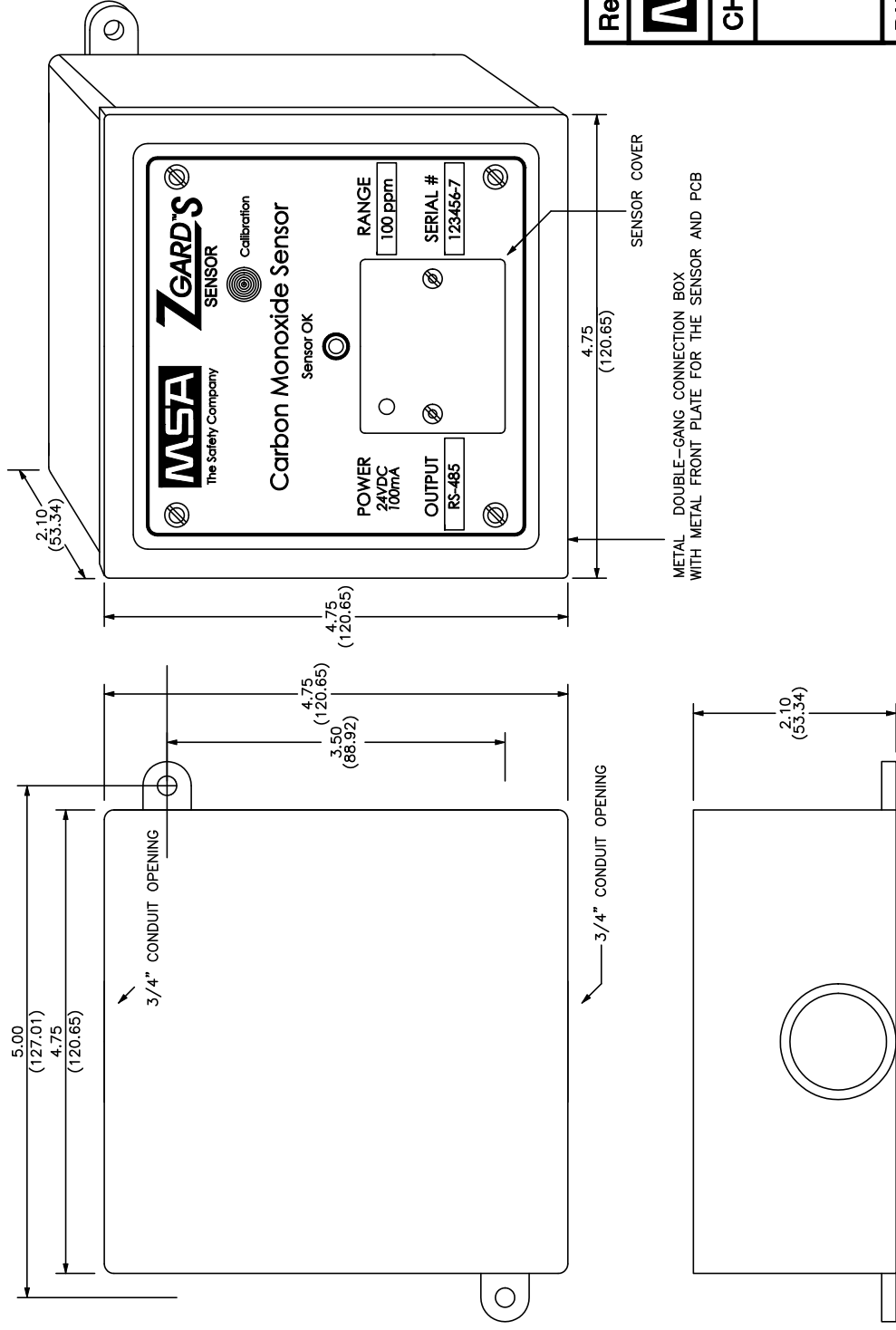

Rev. C ZGARD MAG CAL VERSION



CHKD: V.B DATE: Nov. 16/04 DRN: KS

Installation Outline,
ZGARD S,
RS485 Digital Output Sensors

DWG. NO.: 106896 REV. C

24V A.C. POWER CONNECTION
ZGARD DS SENSOR

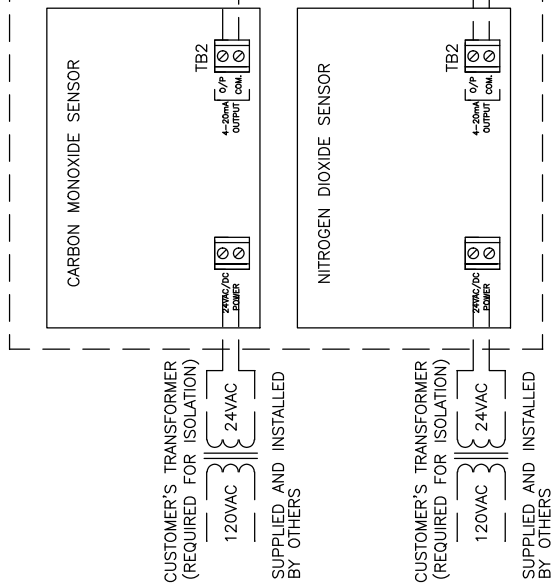

24V D.C. POWER CONNECTION
ZGARD DS SENSOR

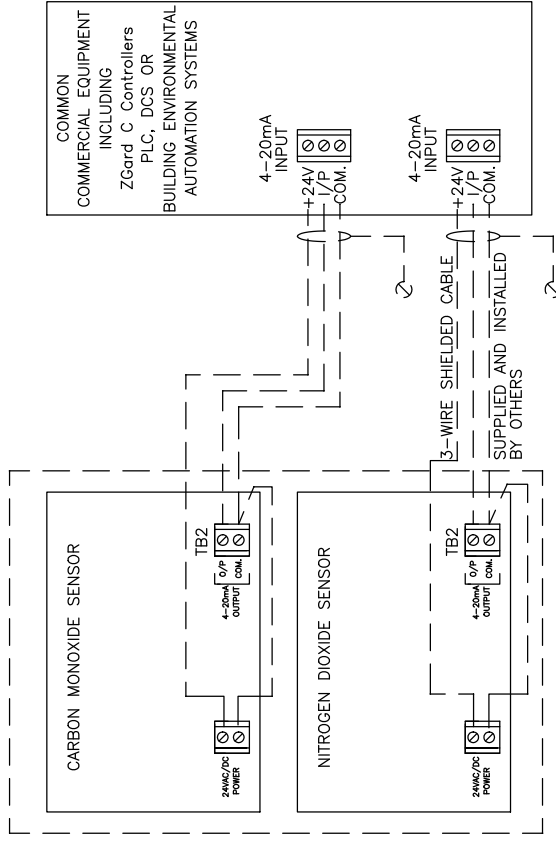

OR

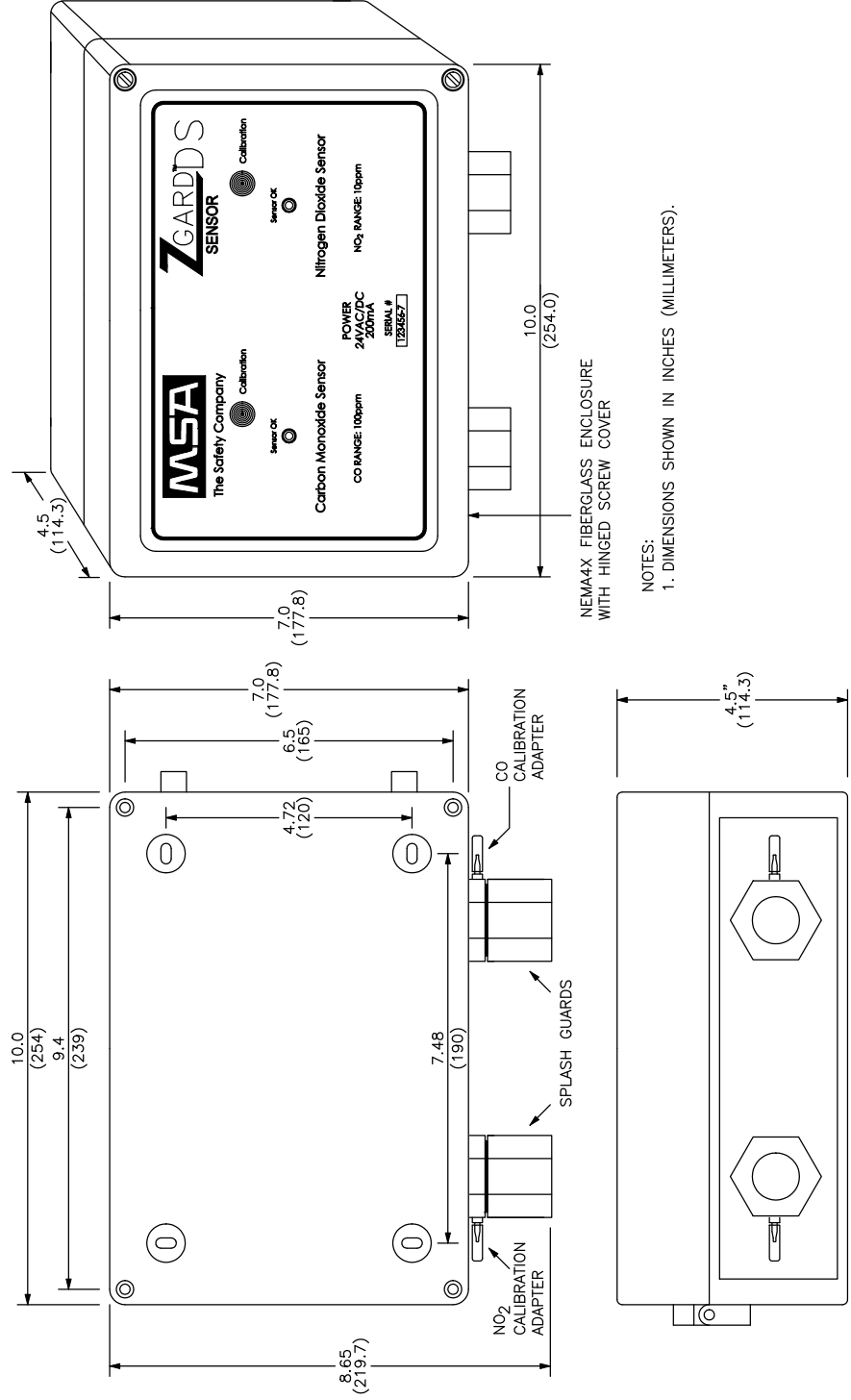

NOTES:
1. DIMENSIONS SHOWN IN INCHES (MILLIMETERS).

CABLE LENGTH VS. SIZE (AWG#)	
CABLE LENGTH FEET	GAUGE (AWG#)
1 TO 5,000	18

SUGGESTED CABLE	
GAUGE (AWG#)	3-WIRE SHIELDED CABLE
18	ALPHA WIRE 5523
GAUGE (AWG#)	2-WIRE SHIELDED CABLE
18	ALPHA WIRE 5522

Rev. C ZGARD MAG CAL VERSION



CHKD: V.E DATE: Jan. 18/05 DRN: KS

Installation Outline,
ZGARD DS,
4-20mA Output Stand-Alone Sensors

DWG. NO.: 106955

REV. D

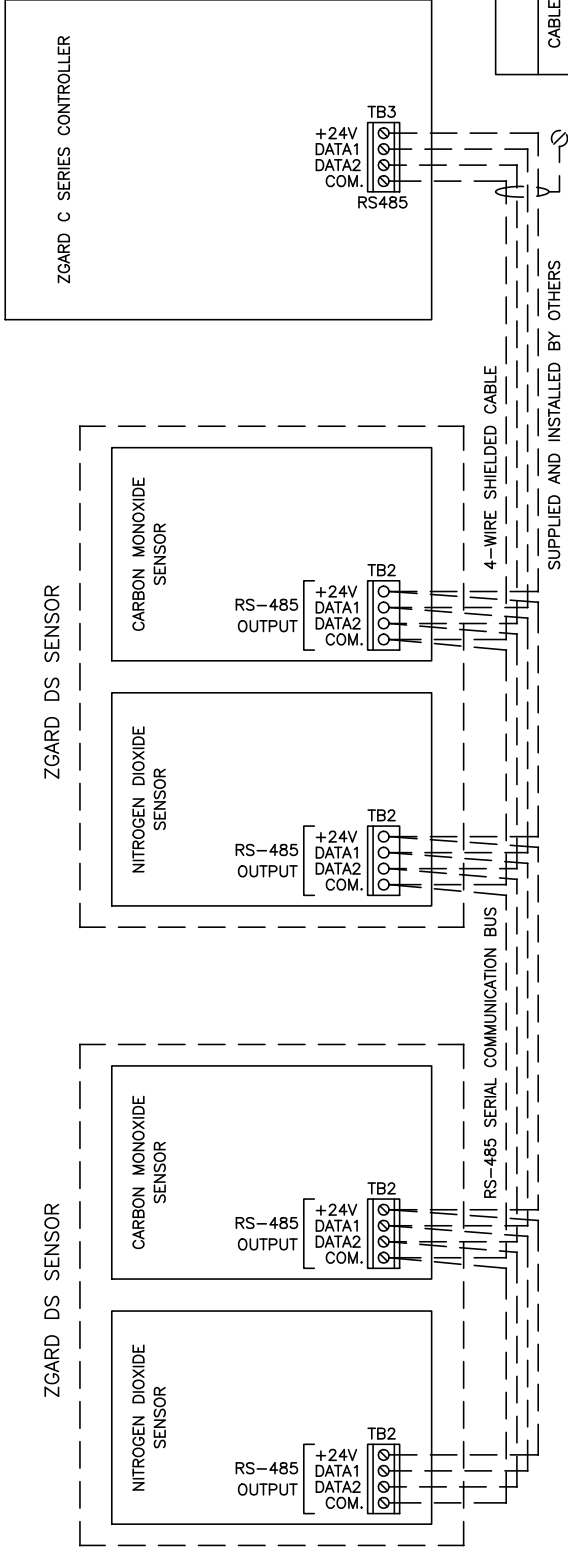

FOR DASY--CHAIN (SERIES) WIRING OF ZGARD DS SENSORS TO AN MSA ZGARD C SERIES CONTROLLER AS SHOWN HERE, EACH SENSOR MUST BE UNIQUELY ADDRESSED VIA JUMPERS ON SENSOR CIRCUIT BOARD.

CABLE LENGTH VS. SIZE (AWG#)								
CABLE LENGTH FEET	No. OF SENSORS	4	6	8	10	12	14	16
1 TO 500	AWG #	22	22	22	22	22	20	20
501 TO 1,000	AWG #	22	20	20	20	18	18	18
1,001 TO 1,500	AWG #	20	18	18	16	16	16	16
1,501 TO 2000	AWG #	18	16	16	14	14	14	14

SUGGESTED CABLE	
GAUGE (AWG#)	4-WIRE SHIELDED CABLE
22	ALPHA WIRE 5504
20	ALPHA WIRE 5514
18	ALPHA WIRE 5524
16	ALPHA WIRE 5534
14	ALPHA WIRE 5544

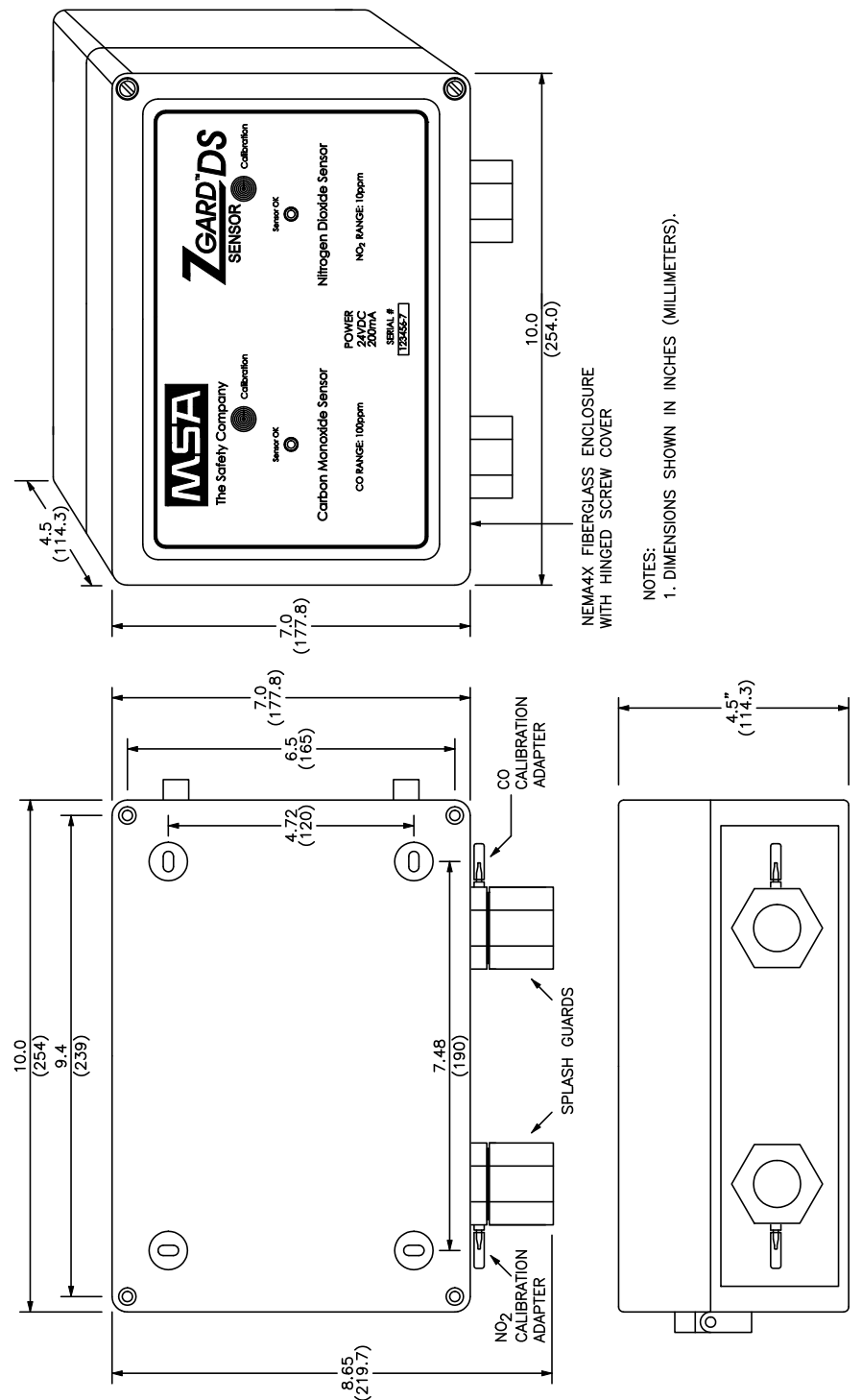

NOTES:
1. DIMENSIONS SHOWN IN INCHES (MILLIMETERS).

Rev. C ZGARD MAG CAL VERSION



CHKD: DATE: Jan. 18/05 DRN: KS

**Installation Outline,
ZGARD DS,
RS485 Digital Output Sensors**

DWG. NO.: 106954 REV. C

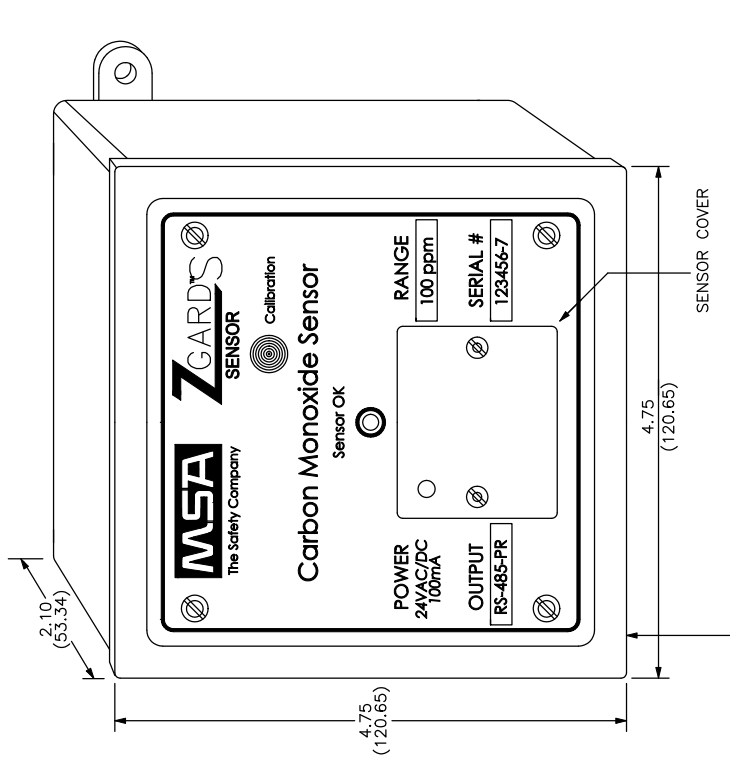

METAL DOUBLE-GANG CONNECTION BOX WITH METAL FRONT PLATE FOR THE SENSOR AND PCB

FOR DAISY-CHAIN (SERIES) WIRING OF ZGARD S SENSORS TO A SIEMENS CONTROLLER AS SHOWN HERE, EACH SENSOR MUST BE UNIQUELY ADDRESSED VIA JUMPERS ON SENSOR CIRCUIT BOARD.
MAXIMUM NUMBER OF SENSORS ON THE RS-485 BUS IS 127.

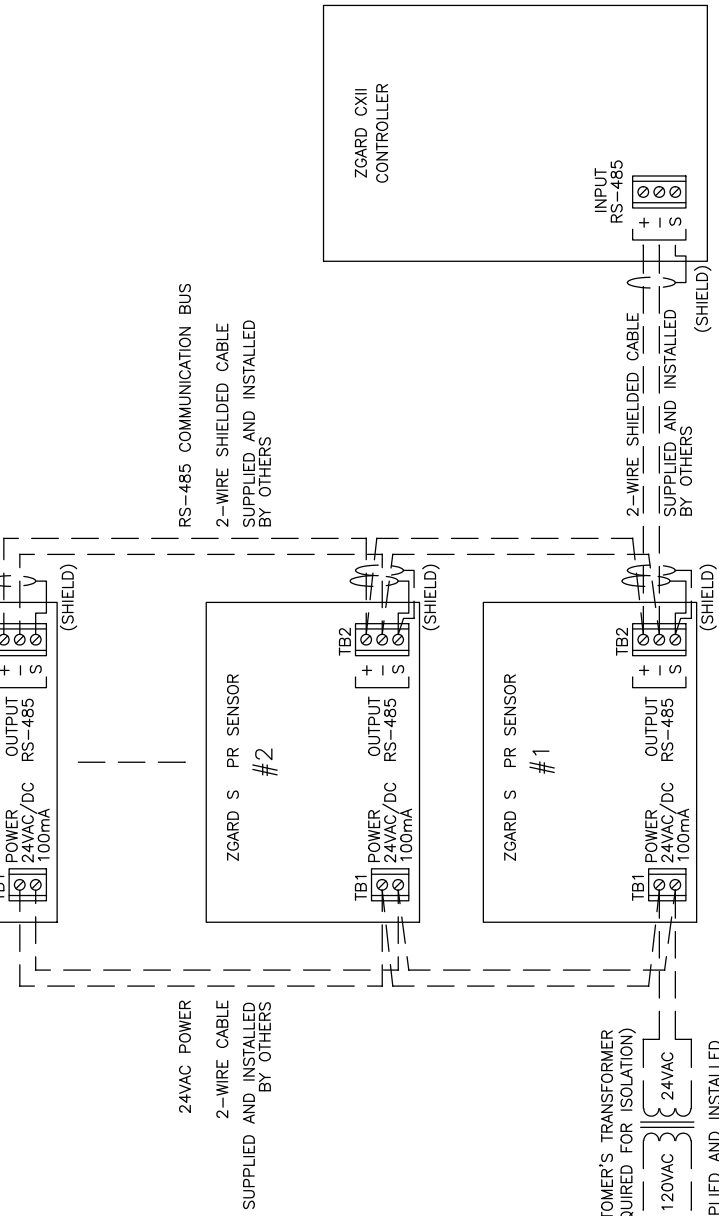

NOTES:
1. DIMENSIONS SHOWN IN INCHES (MILLIMETERS).

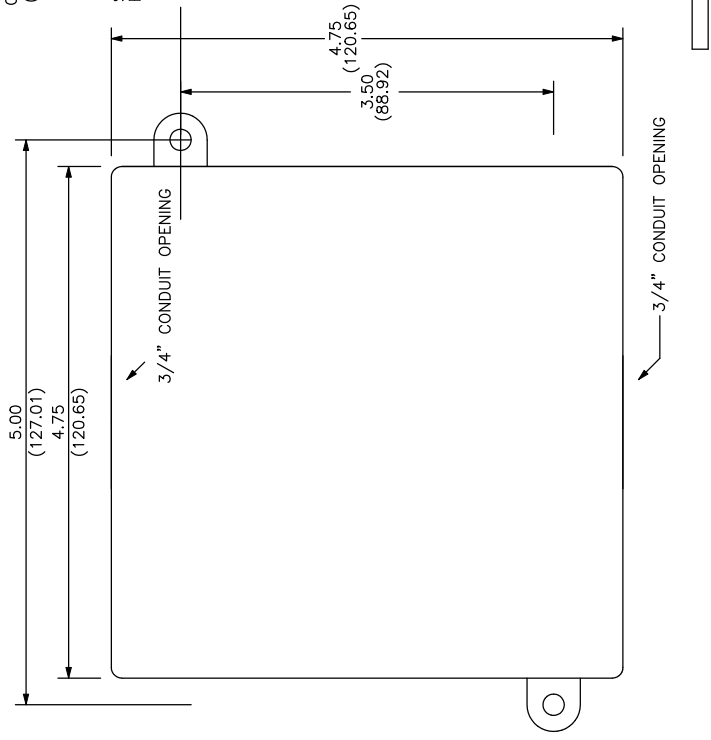

CHKD: V.B DATE: Jan10/13 DRN: D.P

Installation Outline,
ZGARD S PR
RS485-PR Output Sensors

DWG. NO.: 108668 REV. B

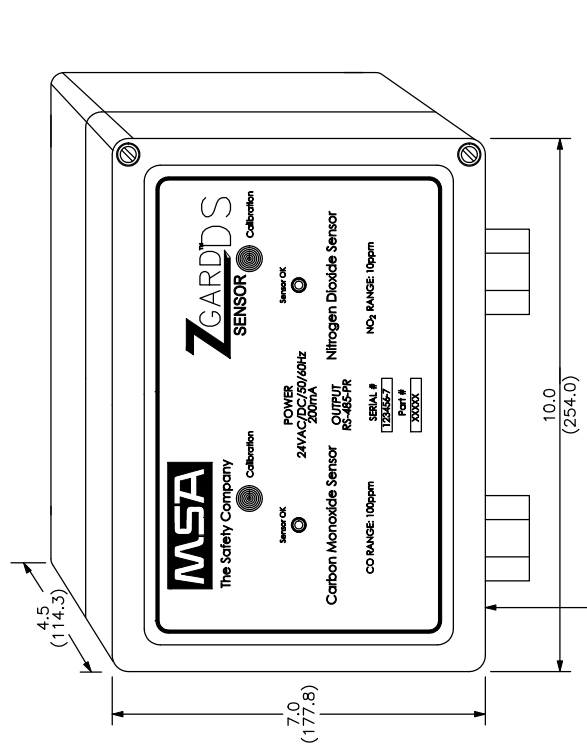

NEMA4X FIBERGLASS ENCLOSURE WITH HINGED SCREW COVER

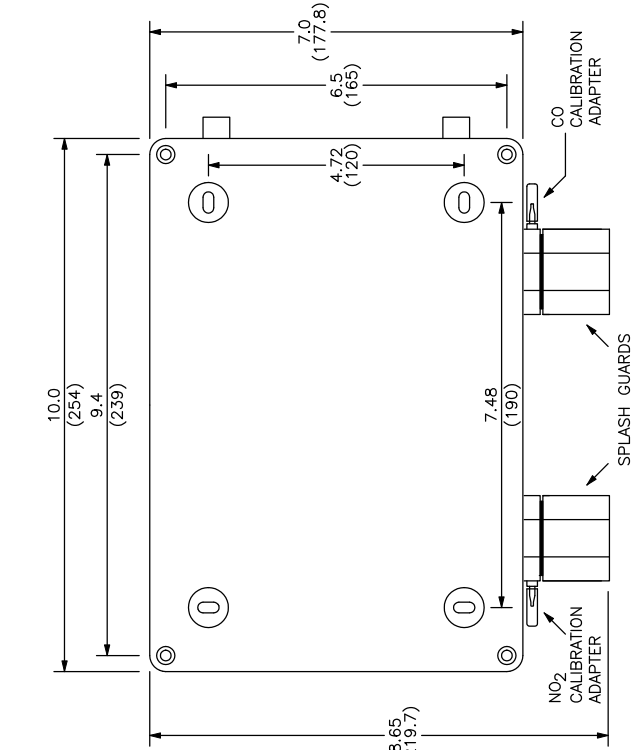

SPLASH GUARDS

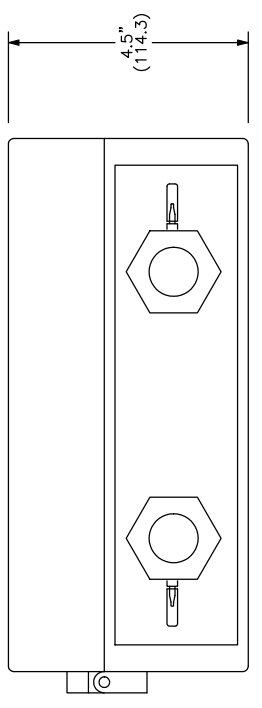

FOR DAISY-CHAIN (SERIES) WIRING OF ZGARD DS SENSORS TO A SIEMENS CONTROLLER AS SHOWN HERE, EACH SENSOR MUST BE UNIQUELY ADDRESSED VIA JUMPERS ON SENSOR CIRCUIT BOARD.
MAXIMUM NUMBER OF SENSORS ON THE RS-485 BUS IS 126.

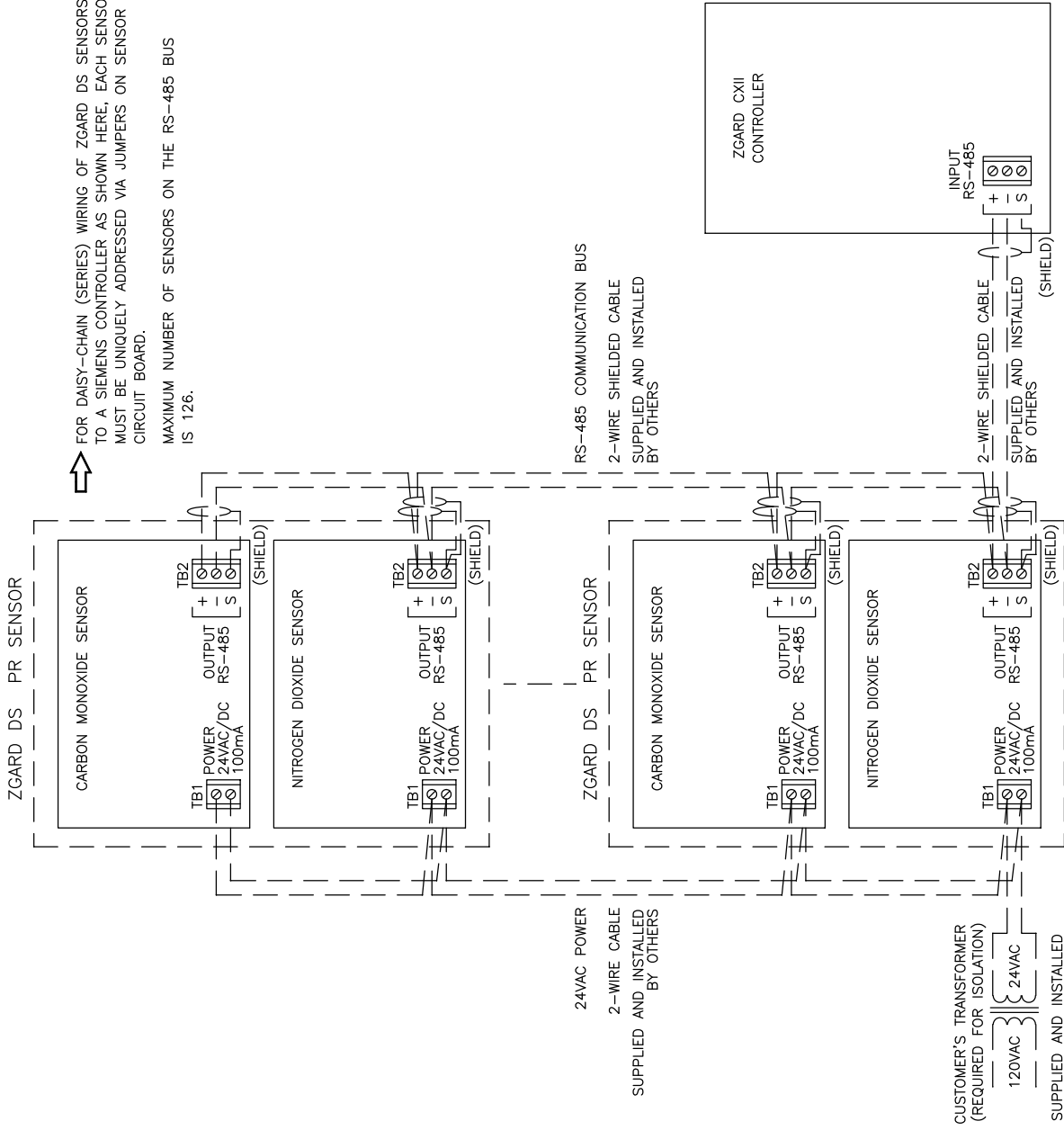

24VAC POWER 2-WIRE CABLE SUPPLIED AND INSTALLED BY OTHERS

CUSTOMER'S TRANSFORMER (REQUIRED FOR ISOLATION) 120VAC 24VAC SUPPLIED AND INSTALLED BY OTHERS

RS-485 COMMUNICATION BUS 2-WIRE SHIELDED CABLE SUPPLIED AND INSTALLED BY OTHERS



CHKD: V.B DATE: Jan. 11/13 DRN: D.P

Installation Outline,
ZGARD DS PR,
RS485-PR Output Sensors

DWG. NO.: 1086669 REV. B

NOTES:
1. DIMENSIONS SHOWN IN INCHES (MILLIMETERS).