

# PALMGREN<sup>®</sup>

## 20" FLOOR MODEL DRILL PRESSES



***Read carefully and follow all safety rules and operating instructions before first use of this product.***

## DESCRIPTION

Dayton Drill Presses feature a heavy cast iron base, column collar, work table and head. Work table height is adjustable using rack and pinion. Table can be tilted 45° both right and left, and rotates 360° on a vertical axis. Work table surface is precision ground and features T-slots for secure, accurate mounting of workpiece and also a coolant trough. Digital readout displays spindle depth and RPM. Other features of Dayton Drill Presses are an enclosed ball bearing quill assembly, quick belt change and tension mechanism, positive quick-adjust feed depth stop and a 1½ HP motor and 16 speeds. Chuck and arbor are included.

Dayton Drill Presses are ideal for use in home shops, maintenance shops and light industrial applications. Spindle speeds are adjustable for drilling steel, cast iron, aluminum, wood and plastic.

## UNPACKING

Refer to Figure 1.

**WARNING:** Be careful not to touch overhead power lines, piping, lighting, etc., if lifting equipment is used. Drill Press weighs over 180 lbs. Proper tools, equipment and qualified personnel should be employed in all phases of unpacking and installation.

Carton should be handled with care to avoid damage from dropping, bumping, etc. Store and unpack carton with correct side up. After unpacking Drill Press, inspect carefully for any damage that may have occurred during transit. Check for loose, missing or damaged parts. If any damage or loss has occurred, claim must be filed with carrier immediately. Check for completeness. Immediately report missing parts to dealer.

Important: The tool has been coated with a protective coating. In order to ensure proper fit and operation the coating must be removed. Remove coating with mild solvents such as mineral spirits and a soft cloth. Nonflammable solvents are recommended. After cleaning, cover all exposed surfaces with a light coating of oil. Paste wax is recommended for table top.

**CAUTION:** Never use highly volatile solvents. Avoid getting cleaning solution on paint as it may tend to deteriorate these finishes. Use soap and water on painted components.

Drill Press is shipped partially assembled. Locate and identify the following assemblies and loose parts:

- A) Head Assembly
- C) Table
- D) Table Bracket
- E) Base
- F) Column Assembly
- G) Quill Feed Handle
- H) Feed Bar Handle
- J) Table Bracket Locking Handle
- K) Table Locking Handle
- L) Chuck & Arbor

Not Shown: Worm gear; four M10 × 1.5-40 hex bolts; wedge; 3 & 5 mm hex wrenches; chuck key; belt tension handle; hardware bag for quill feed handle.

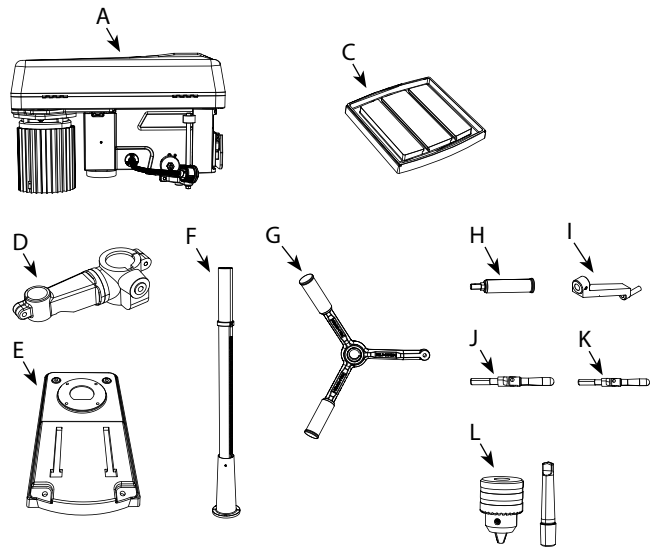

Figure 1 – Unpacking

## SPECIFICATIONS

### Model 9680209A & 9680210A, 20" Floor Model Drill Press

Chuck Size .....	19 mm, JT4
Spindle Taper .....	MT3 × JT4
Spindle Travel .....	6"
Quill Diameter .....	2.44" (62 mm)
Quill Collar Diameter .....	3" (75 mm)
Column Diameter .....	3.62" (92 mm)
Speeds .....	16
RPM .....	140–3600
Swing .....	20"
Table Size .....	18¾" × 16¾"
Table Working Surface .....	16" × 13"
T-Slots (Diagonal) .....	15 mm
Base Size .....	24" × 17⅝"
Base Working Surface .....	16" × 13"
Drilling Capacity (Cast Iron) .....	1"
Distance, Spindle to Table: (Min/Max) .....	6¾" / 28¾"
Distance, Spindle to Base: .....	46½"
Overall Height: .....	69"
Net Weight .....	250 lbs
Shipping Weight .....	268 lbs
<b>9680209A Motor</b> (Prewired for 120V operation) .....	1.5 HP, 1725 RPM, 120/240 V, 14.2/7.1 A, 60 Hz, 1 PH
<b>9680210A Motor</b> .....	1.5 HP, 1725 RPM, 240V, 5 A, 60 Hz, 3PH

## SAFETY RULES

**PROPOSITION 65 WARNING:** Some dust created by using power tools contain chemicals known to the state of California to cause cancer, birth defects or other reproductive harm.

Some examples of these chemicals are:

- Lead from lead-based paints
- Crystalline silica from bricks and cement and other masonry products.
- Arsenic and chromium from chemically treated lumber.

Your risk from these exposures varies, depending on how often you do this type of work. To reduce your exposure to these chemicals; work in a well ventilated area and work with approved safety equipment. Always wear **OSHA/NIOSH** approved, properly fitting face mask or respirator when using such tools.

### BE PREPARED FOR JOB

- Wear proper apparel. Do not wear loose clothing, gloves, neckties, rings, bracelets or other jewelry which may get caught in moving parts of machine.
- Wear protective hair covering to contain long hair.
- Wear safety shoes with non-slip soles.
- Wear safety glasses which comply with United States ANSI Z87.1. Everyday glasses have only impact resistant lenses. They are **NOT** safety glasses.
- Wear face mask or dust mask if cutting operation is dusty.
- Be alert and think clearly. Never operate power tools when tired, intoxicated or when taking medications that cause drowsiness.

### WORK AREA SHOULD BE READY FOR JOB

- Keep work area clean. Cluttered work areas and work benches invite accidents.
- Do not use power tools in dangerous environments. Do not use power tools in damp or wet locations. Do not expose power tools to rain.
- Work area should be properly lighted.
- Proper electrical outlet should be available for tool. Three-prong plug should be plugged directly into properly grounded, three-prong receptacle.
- Extension cords should have a grounding prong, and the three wires of the extension cord should be of the correct gauge.
- Keep visitors at a safe distance from work area.
- Keep children out of workplace. Make workshop childproof. Use padlocks, master switches or remove switch keys to prevent any unintentional use of power tools.

### TOOL SHOULD BE MAINTAINED

- Always unplug tool prior to inspection.
- Read operating instructions manual for specific maintaining and adjusting procedures.
- Keep tool lubricated.
- Use sharp cutters and keep the tool clean for safest operation.
- Remove adjusting tools. Form the habit of checking that adjusting tools are removed before turning on the machine.
- Keep all parts in working order. Check to determine that the guard or other parts will operate properly and perform their intended function.
- Check for damaged parts. Check for alignment of moving parts, binding, breakage, mounting and any other condition that may affect a tool's operation.

- Damaged parts should be properly repaired or replaced. Do not perform makeshift repairs. (Use the parts list provided to order replacement parts.)

### KNOW HOW TO USE TOOL

- Use the right tool for the job. Do not force tool or attachment to do a job for which it was not designed.
- Disconnect tool when changing accessories such as bits, cutters and the like.
- Avoid accidental start-up. Make sure switch is in OFF position before plugging in.
- Do not force tool. It will work most efficiently at the rate for which it was designed.
- Handle workpiece correctly. Secure work with clamps or vise. Leave hands free to operate machine, Protect hands from possible injury.
- Never leave a tool running unattended. Turn the power off and do not leave tool until it comes to a complete stop.
- Do not overreach. Keep proper footing and balance.
- Never stand on tool. Serious injury could occur if tool is tipped or if cutter is unintentionally contacted.
- Keep hands away from moving parts and cutting surfaces.
- Know your tool. Learn its operation, application and specific limitations.
- Feed work into a bit or cutter against the direction of rotation of bit or cutter.
- Turn the machine off if it jams. A cutter jams when it digs too deeply into the workpiece. (The motor force keeps it stuck in workpiece.)
- Use recommended accessories.
- Clamp workpiece or brace against column to prevent rotation.
- Use recommended speed for drill accessory and workpiece material.

**WARNING:** Think Safety! Safety is a combination of operator common sense and alertness at all times when drill press is being used.

## ASSEMBLY

### MOUNT COLUMN ASSEMBLY TO BASE

Refer to Figure 7.

- Place base (Ref. No. 3) on flat level surface.
- Mount column assembly (Ref. No. 7) to base using four hex bolts (Ref. No. 10).

### INSTALL TABLE TO COLUMN ASSEMBLY

Refer to Figure 7.

- Insert the worm gear (Ref. No. 34) into the table crank handle hole from inside the table bracket (Ref. No. 25). Make sure the worm gear (Ref. No. 34) meshes with the inside raising/lowering gear.
- Install the table bracket locking handle (Ref. No. 33) into the hole at the rear of the table bracket (Ref. No. 25).

**NOTE:** Install the handle from left to right, so it enters the non-threaded side of the table bracket first.

- Place the rack (Ref. No. 13) inside the table bracket (Ref. No. 25), making sure the worm gear (Ref. No. 34) on the inside of the table bracket is engaged with the teeth of the rack and the arrow stamped on the rack is pointing up.
- Slide the table bracket with the rack onto the column.

**ASSEMBLY (CONTINUED)**

- Engage the bottom of the rack with the lip of the column support. Tighten the table bracket lock handle to lock the table bracket to the column.
- Install the rack ring (Ref. No. 36) on the column so the top lip of the rack sits into the rack ring.

**IMPORTANT:** The bottom of the collar **MUST NOT** be pushed all the way down onto the top of the rack. **MAKE SURE** the top of the rack is under the bottom of the collar and that there is enough clearance to allow the rack to freely rotate around the column. Tighten the set screw of the rack ring.

**NOTE:** To avoid column or collar damage, **DO NOT OVERTIGHTEN** the set screw.

- Install the table crank handle (Ref. No. 31) onto the worm gear shaft on the side of the table bracket.
- Line up the flat side of the worm gear shaft with the set screw (Ref. No. 28) in the table crank handle (Ref. No. 31) and tighten the screw with the 3 mm hex wrench provided.
- Attach table (Ref. No. 24) to table bracket (Ref. No. 25) using the table locking handle (Ref. No. 22).

**MOUNT HEAD ASSEMBLY**

**WARNING:** Although compact, the drill press head assembly is heavy. Two people are required to mount the drill press head assembly onto the column.

- Carefully lift the head above the column and slide in onto the column. Make sure the head slides down over the column as far as possible. Align the head with the base.
- Using the 5 mm hex wrench, tighten the two head lock set screws (Ref. No. 70) on the right side of the head.

**ATTACH BELT TENSION HANDLE**

Refer to Figure 8.

- Thread handle (Ref. No. 183) into motor mount plate (Ref. No. 184).

**MOUNT QUILL FEED HANDLE ASSEMBLY**

Refer to Figure 8.

- Place key (Ref. No. 146) into feed shaft assembly (Ref. No. 61).
- Place quill feed handle assembly (Ref. No. 147) to the feed shaft assembly.
- Secure quill feed handle assembly with flat head screw (Ref. No. 150) and a washer (Ref. No. 149).
- Thread handle bar (Ref. No. 151) into quill feed handle assembly. (Ref. No. 147).

**INSTALL THE CHUCK**

Refer to Figure 8.

**WARNING:** Before any assembly of the chuck and arbor to the drill press head, clean all mating surfaces with a nonpetroleum based product, such as acetone or alcohol. Any oil or grease used in the packing of these parts must be removed otherwise the chuck may come loose during operation.

- Place the chuck (Ref. No. 131) onto the spindle arbor (Ref. No. 134) while lowering the spindle by turning the feed handles (Ref. No. 147) counterclockwise, until the slot appears on the quill.
- Push the chuck and spindle arbor up into the spindle, making sure the tang is engaged and locked in the inner slot of the spindle. Once tang is oriented correctly, drill duck will not rotate without turning the spindle.

- Open the jaws of the chuck (Ref. No. 131) by rotating the chuck sleeve clockwise. To prevent damage, make sure the jaws are completely retracted into the chuck.

**NOTE:** Clean the taper with acetone or alcohol cleaner before inserting it into the arbor.

- Using a rubber mallet, plastic-tipped hammer, or a block of wood and a hammer, firmly tap the chuck upward into position on the spindle shaft.

**CHUCK KEY STORAGE**

Refer to Figure 8, 9/10.

- Storage holder (Figure 9/10, Ref. No. 68) for the chuck key (Figure 8, Ref. No. 132) is located on the right side of the head.

**INSTALLATION****MOUNT DRILL PRESS**

- Drill press must be mounted to flat level surface. Use shims or machine mounts if necessary. Do not mount drill press in direct sunlight.
- Be sure to bolt drill press to floor or bench securely to prevent tipping and minimize vibration.
- Tighten all nuts and bolts that may have loosened during shipment.

**ELECTRICAL REQUIREMENTS**

The motor is designed for operation on the voltage and frequency specified. Normal loads will be handled safely on voltages not more than 10% above or below the specified voltage.

Running the unit on voltages which are not within the range may cause overheating and motor burn-out. Heavy loads require that the voltage at motor terminals be no less than the voltage specified.

**GROUNDING INSTRUCTIONS**

Refer to Figures 2, 3 and 4.

**WARNING:** Improper connection of equipment grounding conductor can result in the risk of electrical shock. Equipment should be grounded while in use to protect operator from electrical shock. Check with a qualified electrician if grounding instructions are not understood or if in doubt as to whether the tool is properly grounded.

This tool is equipped with an approved 3-conductor cord rated at 300V and a 3-prong grounding type plug for your protection against shock hazards.

Grounding plug should be plugged directly into a properly installed and grounded 3-prong grounding-type receptacle, as shown in Figure 2.

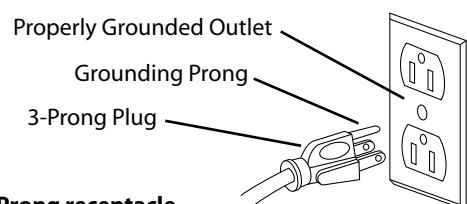

**Figure 2 – 3-Prong receptacle.**

Do not remove or alter grounding prong in any manner. In the event of a malfunction or breakdown, grounding provides a path of least resistance for electrical shock.

**WARNING:** Do not permit fingers to touch the terminals of plug when installing or removing from outlet.

**INSTALLATION (CONTINUED)**

Plug must be plugged into matching outlet that is properly installed and grounded in accordance with all local codes and ordinances. Do not modify plug provided. If it will not fit in outlet, have proper outlet installed by a qualified electrician.

Inspect tool cords periodically, and if damaged, have repaired by an authorized service facility.

Green (or green and yellow) conductor in cord is the grounding wire. If repair or replacement of the electric cord or plug is necessary, do not connect the green (or green and yellow) wire to a live terminal.

Where a 2-prong wall receptacle is encountered, it must be replaced with a properly grounded 3-prong receptacle installed in accordance with National Electric Code and local codes and ordinances.

**WARNING:** This work should be performed by a qualified electrician.

A temporary 3-prong to 2-prong grounding adapter (See Figure 3) is available for connecting plugs to a two pole outlet if it is properly grounded.

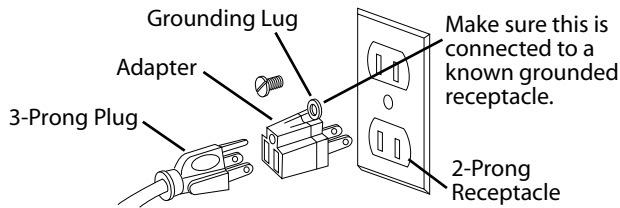

**Figure 3 – 2-Prong receptacle with adapter.**

Do not use a 3-prong to 2-prong grounding adapter unless permitted by local and national codes and ordinances.

(A 3-prong to 2-prong grounding adapter is not permitted in Canada.) Where permitted, the rigid green tab or terminal on the side of the adapter must be securely connected to a permanent electrical ground such as a properly grounded water pipe, a properly grounded outlet box or a properly grounded wire system.

Many cover plate screws, water pipes and outlet boxes are not properly grounded. To ensure proper ground, grounding means must be tested by a qualified electrician.

**EXTENSION CORDS**

- The use of any extension cord will cause some drop in voltage and loss of power.
- Wires of the extension cord must be of sufficient size to carry the current and maintain adequate voltage.
- Running the unit on voltages which are not within  $\pm 10\%$  of the specified voltage may cause overheating and motor burn-out.
- Use the table to determine the minimum wire size (A.W.G.) extension cord.
- Use only 3-wire extension cords having 3-prong grounding type plugs and 3-pole receptacles which accept the tool plug.
- If the extension cord is worn, cut or damaged in any way, replace it immediately.

Extension Cord Table						
		Volts	Total Length of Cord in Feet			
Ampere Rating		120	25	50	100	150
More Than	Not More Than	240	50	100	150	300
			Minimum Gage for Cord			
0	6		18	16	16	14
6	10		18	16	14	12
10	12		16	16	14	12
12	16		14	12	Not Recommended	

**Power Source**

For 9680209A single-phase: Drill Press requires a 120/240 volt, 60 Hz power source. NOTE: Drill press is prewired for 120V operation. To use the drill press with a 240V power supply, have a qualified electrician attach a 240 volt, 20/30A, 3-prong plug.

**ELECTRICAL CONNECTIONS**

Refer to Figure 4.

**WARNING:** All electrical connections must be performed by a qualified electrician. Make sure unit is off and disconnected from power source while motor is mounted, connected, reconnected or anytime wiring is inspected.

- The motor should be wired for 120 volts and clockwise rotation as viewed from shaft end of motor.
- A label on the motor describes the possible wiring configurations. There are many different possible combinations, so only the diagram provided with the motor should be used.
- The power supply to motor is controlled by a push button switch. Power lines are connected to the quick connect terminals of the switch.
- The green ground line must remain securely fastened to the motor ground terminal to provide proper grounding.
- To operate drill press at 240 volts, rewire motor as shown in Figure 4 and replace line cord plug with a 240 volt, 20/30A, 3-prong plug. If motor label has a different wiring configuration, use the motor label diagram to rewire motor.

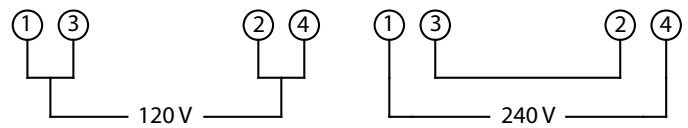

**Figure 4 – Wiring schematic for 9680209A single-phase motor.**

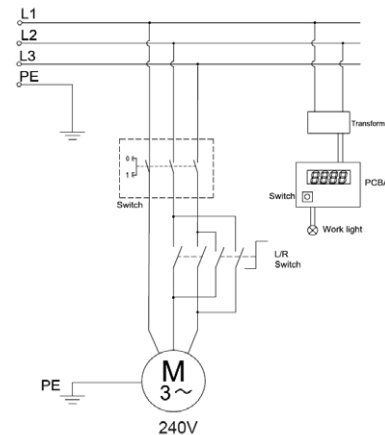

**Figure 4 – Wiring schematic for 9680210A three-phase motor.**

**OPERATION**

**WARNING:** Read and understand operating instructions and parts manual before operating this machine.

**CAUTION:** The operation of any power tool can result in foreign objects being thrown into the eyes, which can result in severe eye damage. Always wear safety glasses complying with United States ANSI Z87.1 (shown on package) before commencing power tool operation.

**STARTING AND STOPPING THE DRILL PRESS**

Refer to Figure 9/10.

**WARNING:** Be sure drill bit is not in contact with workpiece when motor is started. Start motor and allow bit to come up to full speed before drilling.

- The ON/OFF switch (Ref. No. 47/48) is located on the front of the head casting.
- To turn the drill press on, push START button. Always allow drill bit to come up to speed before drilling.

**OPERATION (CONTINUED)**

- To turn the drill press off, press the large red OFF paddle or lift the paddle and press directly on the red OFF button. Do not leave drill press until the bit has come to a complete stop.

**SPEED ADJUSTMENTS**

Refer to Figure 5 and charts on page 7, and Figure 8.

**WARNING:** Be sure drill press is turned off and is disconnected from power source before adjusting speeds.

- To change spindle speed, loosen motor lock handle (Ref. No. 187), pivot the motor toward front of drill press. This will loosen the belt and permit relocating the belt to the desired pulley groove for the required spindle speed (See Figure 5 and charts, page 8).
- After belt has been repositioned, turn handle (Ref. No. 183) to move motor toward rear of drill press and tighten motor lock handle.
- Check belt for proper tension and make any final adjustment. A belt is properly tensioned when light pressure applied to midpoint of the belt produces about 1/2" deflection.

**TABLE ADJUSTMENTS**

Refer to Figure 7.

- Height adjustments: To adjust table, loosen locking handle (Ref. No. 33) and turn crank handle (Ref. No. 31) to desired height. Immediately retighten table bracket locking handle.
- Rotation of work table : Loosen table locking handle (Ref. No. 22)

and rotate table (Ref. No. 24) to desired position and retighten handle.

- Tilting work table: Loosen hex bolt (Ref. No. 20). Remove pin (Ref. No. 16) by loosening hex nut (Ref. No. 17). Tilt table to desired angle up to 45° and retighten bolt. Reinsert pin and nut when returning the table to 0° position.
- To obtain more distance between chuck and table, the work table can be rotated 180° and base can be used as a work surface. This permits drilling of larger objects.
- Clamp table securely after adjustments have been made.

**DEPTH STOP ADJUSTMENT**

Refer to Figure 8.

To control drilling depth, use scale (Ref. No. 128) to adjust to desired depth. Depress and hold pin, slide depth stop nut (Ref. No. 130) along lead screw until bottom edge of nut coincides with the desired depth on the scale, then release pin. Use this feature to drill more than one hole to the same depth.

**MOUNT DRILL BIT**

Refer to Figure 8.

**WARNING:** To avoid injury or accident by the chuck key ejecting forcibly from the chuck when the power is turned on, use only the self-ejecting chuck key supplied with this drill press. ALWAYS recheck and remove the chuck key before turning the power on. Be sure drill press is turned off and is disconnected from power source before adjusting speeds.

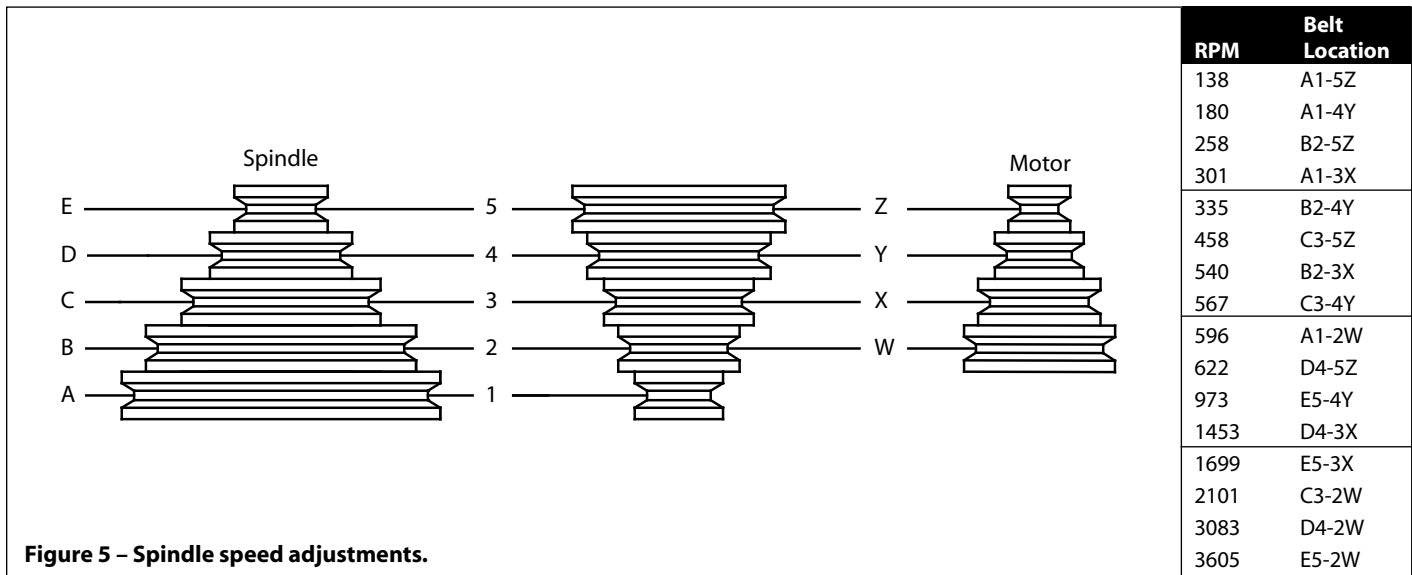

Figure 5 – Spindle speed adjustments.

RPM	Wood		Zinc Diecast		Aluminum & Brass		Plastic		Cast Iron & Bronze		Steel - Mild & Malleable		Steel - Cast & Med. Carbon		Steel - Stainless & Tool	
	in.	mm	in.	mm	in.	mm	in.	mm	in.	mm	in.	mm	in.	mm	in.	mm
3605	5/16	7.9	3/16	4.8	11/64	4.4	5/32	4.0	7/64	2.8	3/32	2.4	1/16	1.6	1/32	0.8
2101	5/8	15.9	3/8	9.5	11/32	8.7	5/16	7.9	1/4	6.4	5/32	4.0	1/8	3.2	1/16	1.6
1699	3/4	19.0	7/16	11.1	13/32	10.3	3/8	9.5	5/16	7.9	3/16	4.8	1/8	3.2	1/16	1.6
1453	7/8	22.2	1/2	12.7	15/32	11.9	7/16	11.1	11/32	8.7	1/4	6.4	3/16	4.8	1/8	3.2
973	1	25.4	5/8	15.9	1/2	12.7	1/2	12.7	3/8	9.5	5/16	7.9	1/4	6.4	3/16	4.8
596	1 1/4	31.8	3/4	19.0	11/16	17.5	5/8	15.9	1/2	12.7	3/8	9.5	5/16	7.9	1/4	6.4
458	1 5/8	41.3	7/8	22.2	3/4	19.0	13/16	20.6	5/8	15.9	1/2	12.7	7/16	11.1	3/8	9.5
335	1 3/4	44.4	15/16	23.8	13/16	20.6	7/8	22.2	3/4	19.0	5/8	15.9	1/2	12.7	7/16	11.1
258	2	50.8	1	25.4	—	—	—	—	—	—	—	—	9/16	14.3	—	—

Recommended speed based on material and drill bit size.

**OPERATION (CONTINUED)**

- Place drill bit in jaws of drill chuck.
- Tighten chuck with drill chuck key. Be sure to tighten the chuck using all three key positions on the chuck body and remove chuck key.
- Use only the self-ejecting chuck key (Ref. No. 132) supplied with this drill press, or a duplicate key. Use of any other key might allow start up with the key still in the chuck. An airborne key could strike the operator and cause injury.

**REMOVE THE CHUCK**

Refer to Figure 8.

- With the switch "OFF" and unit unplugged, adjust the depth stop nut (Ref. No. 130) to hold the drill at a depth of 3 in. (7.6 cm).
- Align the key holes in the spindle and quill rotating the chuck by hand.
- Insert the key wedge (Ref. No. 142) into the key holes. Tap the key wedge lightly with a plastic tipped hammer, until the chuck and arbor fall out of spindle.

**NOTE:** Place one hand below the chuck to catch it when it falls out.

**DIGITAL DISPLAY PANEL**

Refer to Figure 6.

- Display panel (A) shows the spindle RPM.
- Button (B) turns power on and off to LED light.

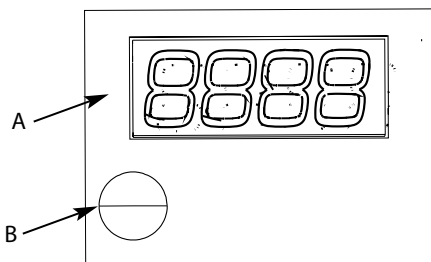

**Figure 6 – Digital display panel.**

**MAINTENANCE**

**WARNING:** Turn switch off and remove plug from power source outlet before maintaining or lubricating your drill press

**DRIVE BELT**

Replace drive belt when worn.

**LUBRICATION**

Refer to Figures 7 and 8.

The ball bearings are lubricated at the factory and need no further lubrication. Using 20wt. non detergent oil, periodically lubricate the splines (grooves) in the spindle and the rack (teeth on the quill) as follows:

- Lower quill assembly (Figure 8, Ref. No. 147) all the way down.
- Apply lubricant around the inside of the hole in the spindle pulley (Figure 8, Ref. Nos. 158 & 172).
- Apply lubricant to rack (teeth) on quill (Figure 8, Ref. No. 144) while extended below drill press head.
- Apply lubricant to rack and pinion gear (Figure 7, Ref. Nos. 13 & 34) on column and table assembly.

**CLEAN MOTOR**

Frequently blow out any dust that may accumulate inside motor. If power cord is worn, cut or damaged in any way, have it replaced immediately.

**IMPORTANT:** To assure product SAFETY and RELIABILITY, repairs, maintenance and adjustment (other than those listed in this manual) should be performed by authorized service centers or other qualified service organizations, always using identical replacement parts.

**WARNING:** To avoid shock or fire hazard, if the power lead is worn or cut in any way, replace it immediately.

## TROUBLESHOOTING

<b>SYMPTOM</b>	<b>POSSIBLE CAUSE(S)</b>	<b>CORRECTIVE ACTION</b>
Spindle does not turn	<ol style="list-style-type: none"> <li>1. No power to drill press</li> <li>2. Defective switch</li> <li>3. Defective motor</li> </ol>	<ol style="list-style-type: none"> <li>1. Check wiring, fuse or circuit breaker</li> <li>2. Replace switch</li> <li>3. Replace motor</li> </ol>
Noisy spindle	Defective bearings	Replace bearings
Noisy operation	<ol style="list-style-type: none"> <li>1. Incorrect belt tension</li> <li>2. Dry spindle</li> <li>3. Loose spindle</li> <li>4. Loose motor pulley</li> </ol>	<ol style="list-style-type: none"> <li>1. Adjust tension</li> <li>2. Lubricate spindle, See Lubrication, page 7</li> <li>3. Tighten pulley nut</li> <li>4. Tighten set screw in pulley</li> </ol>
Bit burns or smokes	<ol style="list-style-type: none"> <li>1. Incorrect speed</li> <li>2. Chips not coming out of table</li> <li>3. Dull bit</li> <li>4. Feeding too slow</li> <li>5. Bit not lubricated</li> <li>6. Bit running backwards</li> </ol>	<ol style="list-style-type: none"> <li>1. Change speed</li> <li>2. Retract bit frequently to clear chips</li> <li>3. Sharpen or replace bit</li> <li>4. Feed faster; enough to allow drill to cut</li> <li>5. Lubricate bit</li> <li>6. Check motor rotation to be sure it is clockwise facing shaft end</li> </ol>
Excessive drill runout or wobble	<ol style="list-style-type: none"> <li>1. Bent bit</li> <li>2. Bit not properly installed in chuck</li> <li>3. Chuck not properly installed</li> <li>4. Worn spindle bearings</li> </ol>	<ol style="list-style-type: none"> <li>1. Replace bit</li> <li>2. Install bit properly</li> <li>3. Install chuck properly</li> <li>4. Replace bearings</li> </ol>
Drill bit binds in workpiece	<ol style="list-style-type: none"> <li>1. Workpiece pinching bit or excessive feed</li> <li>2. Improper belt tension</li> <li>3. Workpiece not supported or clamped properly</li> </ol>	<ol style="list-style-type: none"> <li>1. Support or clamp work, decrease feed pressure</li> <li>2. Adjust tension</li> <li>3. Support or clamp workpiece securely</li> </ol>



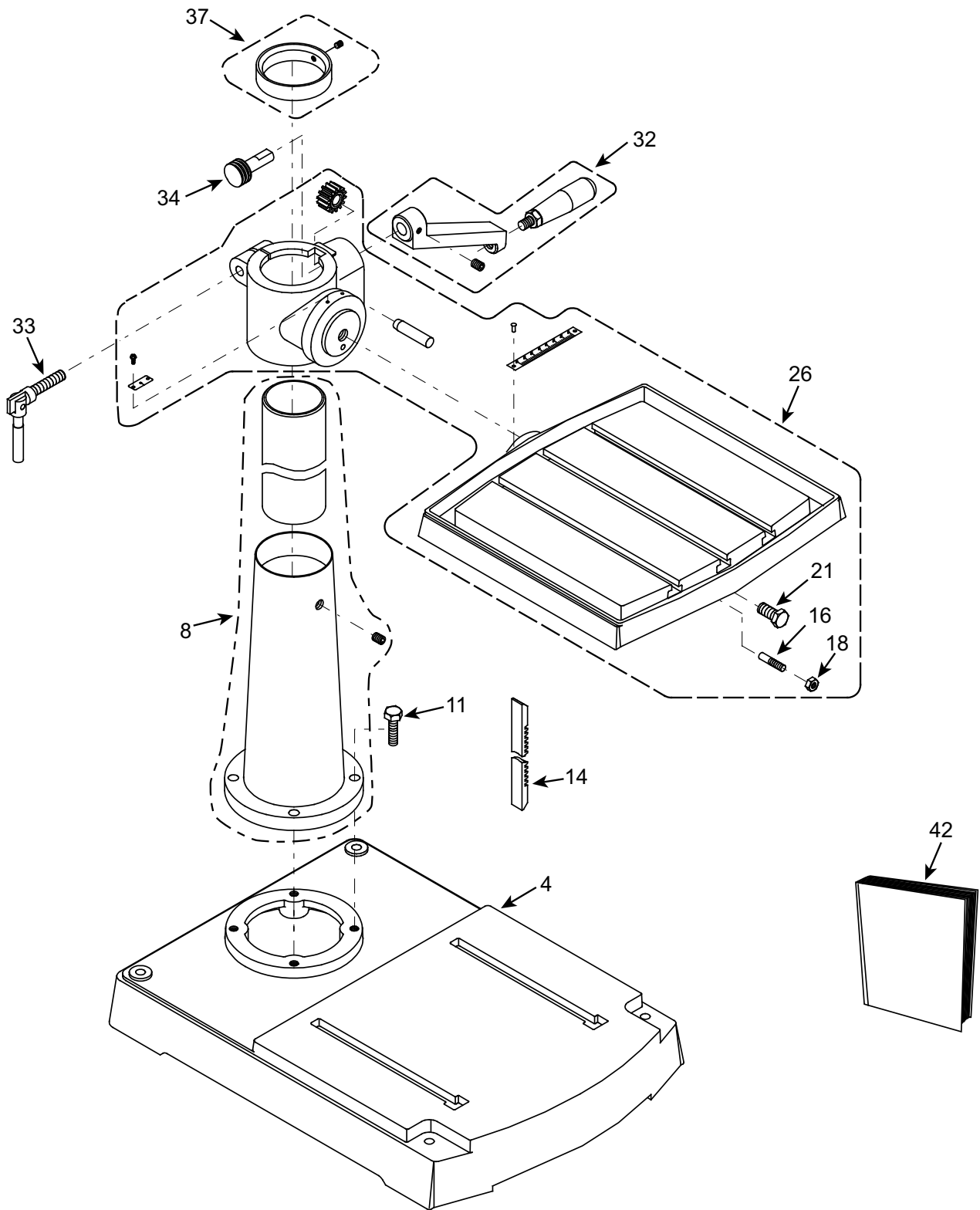

Figure 7 – Replacement Parts Illustration for Base, Column & Table.

## REPLACEMENT PARTS LIST FOR BASE, COLUMN & TABLE

Ref. No.	Description	Part Number	Qty.
4	Base	963163506	1
8	Column Holder Assembly	963195806	1
11	Hex Head Bolt, M12×1.75-40	*	4
14	Rack	963195905	1
16	Location Pin	963197205	1
18	Hex Nut, 1/4×20UNC T=4.7	*	1
21	Hex Head Bolt, 5/8-11UNC-2	*	1
26	Table Assembly	963197305	1
32	Crank Handle Assembly	963212511	1
33	Column Lock Handle	963297605	1
34	Worm	963212305	1
37	Rack Ring Assembly	963097806	1
42	Instruction Manual	964827906	

(Δ) Not shown.

(N/A) Not available as repair part.

(\*) Standard hardware item, available locally.

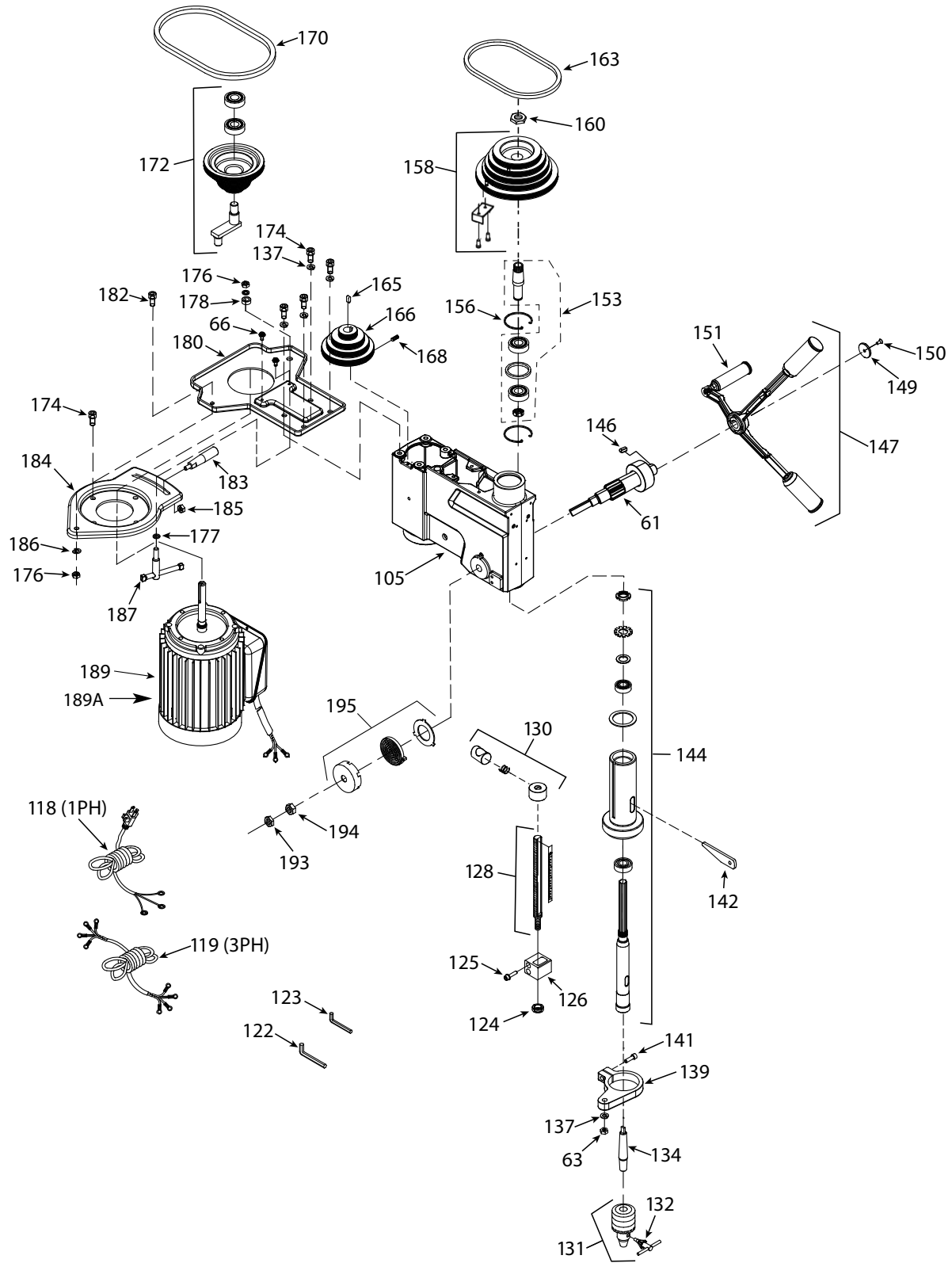

Figure 8 – Replacement Parts Illustration for Spindle & Drive.

## REPLACEMENT PARTS LIST FOR SPINDLE & DRIVE

Ref. No.	Description	Part Number	Qty.
61	Feed Shaft Assembly	963202106	1
63	Hex Nut, M10×1.5 T=8	*	1
66	Round Washer Head Screw, M6×1.0-12	*	4
105	Head	N/A	1
118	Power Cable for 9680209A Single-Phase	965018801	1
119	Power Cable for 9680210A Three-Phase	963214610	1
122	Hex Wrench, 5 mm	960015005	1
123	Hex Wrench, 3 mm	960014905	1
124	Circular Nut	963206605	1
125	Hex Socket Head Cap Screw, M6×1.0-40	*	2
126	Plunger Housing	963206705	1
128	Set Bolt Assembly	963202615	1
130	Depth Stop Nut	963202905	1
131	Chuck & Key	963213810	1
132	Chuck Key	963213910	1
134	Drilling Arbor, MT2×JT3	962792610	1
137	Spring Washer	*	5
139	Set Ring	963213615	1
141	Hex Socket Head Cap Bolt, M8×1.25-20	*	1
142	Wedge Shifter	961890905	1
144	Spindle Assembly	963213716	1
146	Parallel Key	963202005	1
147	Handle Assembly	963214111	1
149	Washer	963201706	1
150	Screw, M5×0.8-12	963200406	1
151	Handle Bar Assembly	963201806	1
153	Driving Sleeve Assembly	965018701	1
156	Retaining Ring	965018601	2
158	Pulley & Magnet Assembly	963212711	1
160	Pulley Set Nut, φ22.5	963212610	1
163	V-Ribbed Belt, Polyurethane (330J4)	963218015	1
165	Parallel Key	960788505	1
166	Motor Pulley	963215110	1
168	Hex Socket Set Screw, M6×1.0-16	*	1
170	V-Ribbed Belt, Polyurethane (290J4)	963218010	1
172	Pulley Assembly	963213216	1
174	Hex Socket Head Cap Bolt, M10×1.5-20	*	8
176	Chuck Nut, M10×1.5 T=10	*	2
177	Nylon Washer, φ10×20-2	*	2
178	Collar	960053305	1
180	Motor Retaining Clip	963218411	1
182	Hex Socket Head Cap Bolt, M10×1.5-25	*	1
183	Handle Shifter	963214805	1
184	Motor Bracket	963214905	1
185	Hex Nut, M10×1.5 T=8	*	1
186	Spring Washer, φ12	*	1
187	Locking Handle Assembly	963214505	1
189	Motor Assembly for 9680209A Single-Phase	963218121	1
189A	Motor Assembly for 9680210A Three-Phase	963218126	1
193	Hex Nut, 1/2×20UNF T=6.5	*	1
194	Hex Nut, 1/2×20UNF T=10	*	1
195	Plate Spring Assembly	963213310	1

(Δ) Not shown.

(N/A) Not available as repair part.

(\*) Standard hardware item, available locally.

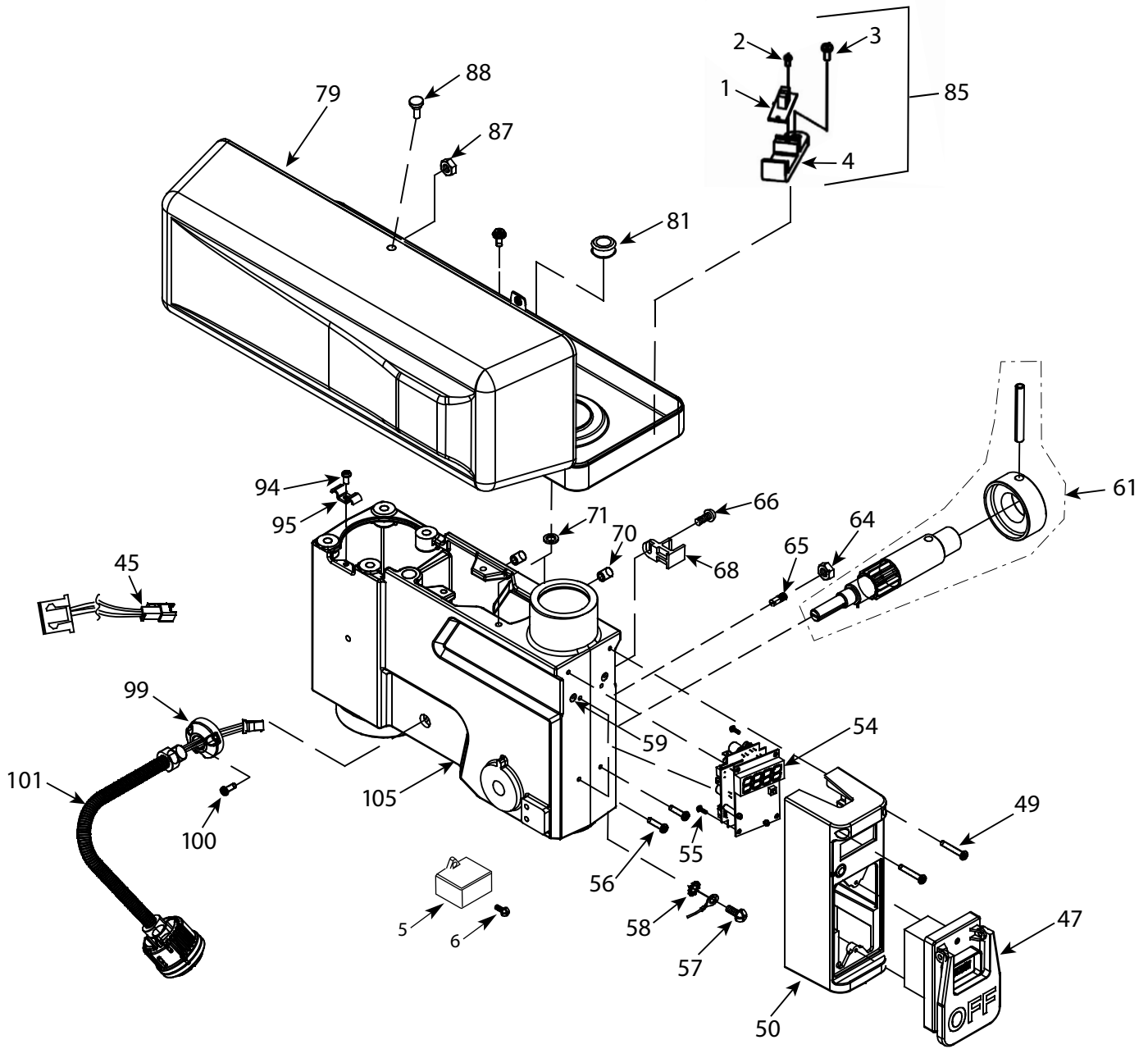

Figure 9 – Replacement Parts Illustration for 9680209A Single-Phase Head.

## REPLACEMENT PARTS LIST FOR 9680209A SINGLE-PHASE HEAD

Ref. No.	Description	Part Number	Qty.
1	Speed Sensor	N/A	1
2	Self-Tapping Screw, ST2.2×6.5	*	2
3	Screw, GB8 18-86 M4×25	*	2
4	Receiver Seat	N/A	1
5	DC Power Supply	964748901	1
6	Pan Head Screw, M5×0.8-8	*	1
45	Lead Wire Assembly	965018901	1
47	Switch Assembly	963215705	1
49	Pan Head Screw, M5×0.8-35	*	2
50	Switch Box Assembly	963204506	1
54	Controller Assembly	963216006	1
55	Pan Head Tapping Screw, M3×24-6	*	4
56	Round Washer Head Screw, M5×0.8-16	*	2
57	Pan Head Screw, M5×0.8-8	*	2
58	External Tooth Lock Washer, φ5	*	2
61	Feed Shaft Assembly	963202106	1
64	Hex Nut, M10×1.5 T=8	*	1
65	Quill Set Screw	963213505	1
66	Round Washer Head Screw, M6×1.0-12	*	1
68	Chuck Key Holder	963215805	1
70	Hex Socket Set Screw, M10×1.5-12	*	2
71	Flat Washer, φ8.5×22-3	*	4
79	Pulley Cover Assembly	963203806	1
81	Strain Relief	963204105	1
85	Speed Sensor Assembly	963204206	1
87	Hex Nut, M8×1.25 T=5	*	1
88	Captive Screw	963203705	1
94	Pan Head Screw, M5×0.8-10	*	1
95	Cord Clamp	963215605	1
99	Lamp Socket	963205805	1
100	Hex Socket Head Cap Screw, M5×0.8-16	*	3
101	Lamp Assembly	963206406	1
105	Head	N/A	1

(Δ) Not shown.

(N/A) Not available as repair part.

(\*) Standard hardware item, available locally.

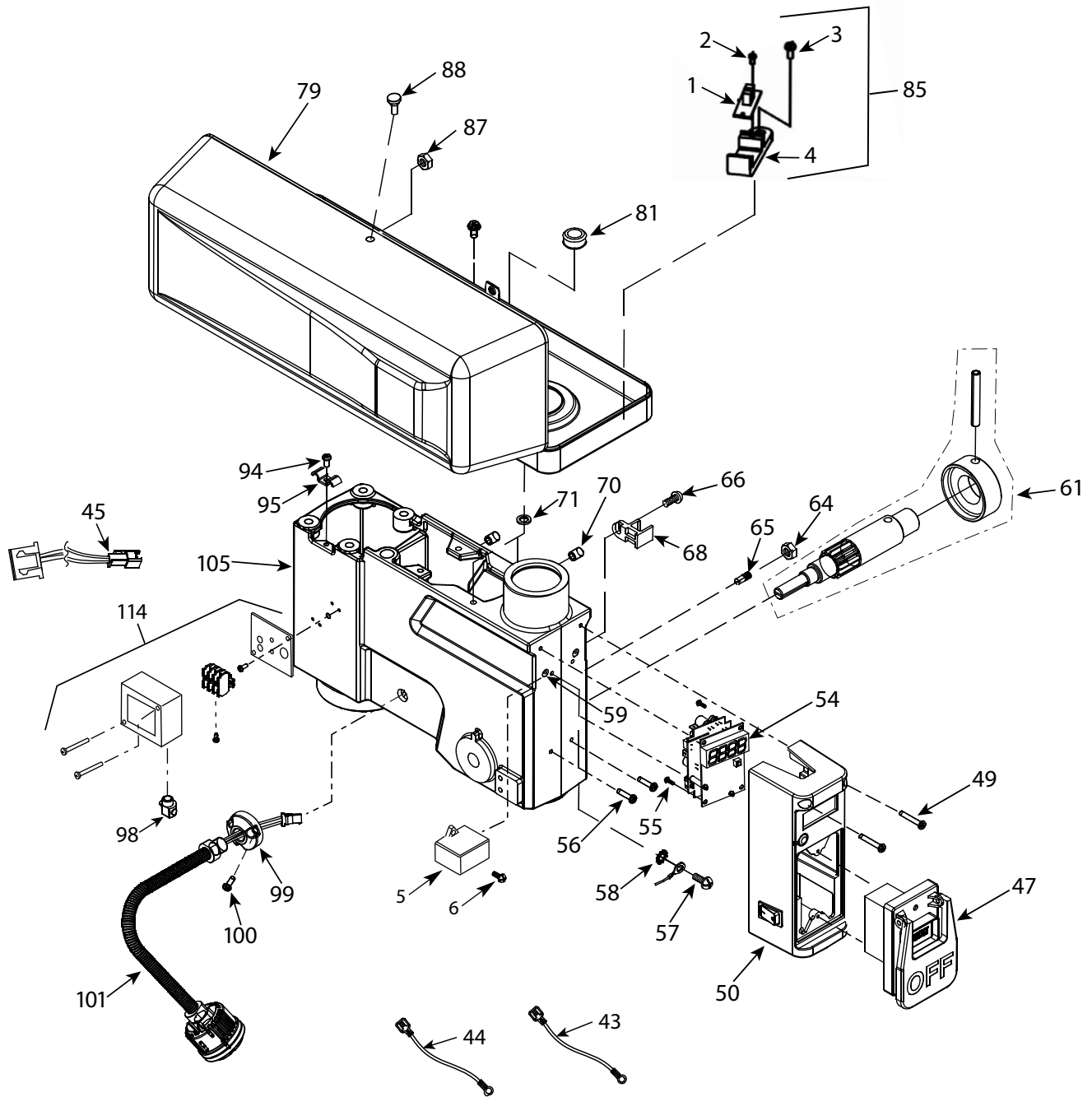

Figure 10 – Replacement Parts Illustration for 9680210A Three-Phase Head.

## REPLACEMENT PARTS LIST FOR 9680910A THREE-PHASE HEAD

Ref. No.	Description	Part Number	Qty.
1	Speed Sensor	N/A	1
2	Self-Tapping Screw, ST2.2×6.5	*	2
3	Screw, GB8 18-86 M4×25	*	2
4	Receiver Seat	N/A	1
5	DC Power Supply	964748901	1
6	Pan Head Screw, M5×0.8-8	*	1
39	Drive Screw, φ2.3-5	*	4
43	Lead Wire Assembly	960006800	1
44	Lead Wire Assembly	960006900	1
45	Lead Wire Assembly	960007000	1
47	Switch Assembly	963204405	1
49	Pan Head Screw, M5×0.8-35	*	2
50	Switch Box Assembly	963204506	1
54	Controller Assembly	963216006	1
55	Pan Head Tapping Screw, M3×24-6	*	4
56	Round Washer Head Screw, M5×0.8-16	*	2
57	Pan Head Screw, M5×0.8-8	*	2
58	External Tooth Lock Washer, φ5	*	2
61	Feed Shaft Assembly	963202106	1
64	Hex Nut, M10×1.5 T=8	*	1
65	Quill Set Screw	965019001	1
66	Round Washer Head Screw, M6×1.0-12	*	1
68	Chuck Key Holder	963215805	1
70	Hex Socket Set Screw, M10×1.5-12	*	2
71	Flat Washer, φ8.5×22-3	*	4
79	Pulley Cover Assembly	963203806	1
81	Strain Relief	963204105	1
85	Speed Sensor Assembly	963204206	1
87	Hex Nut, M8×1.25 T=5	*	1
88	Captive Screw	963203705	1
94	Pan Head Screw, M5×0.8-10	*	1
95	Cord Clamp	963215605	1
98	Strain Relief	963204405	2
99	Lamp Socket	963205805	1
100	Hex Socket Head Cap Screw, M5×0.8-16	*	3
101	Lamp Assembly	963206405	1
105	Head	N/A	1
114	Connector Box Assembly	963108900	1

(Δ) Not shown.

(N/A) Not available as repair part.

(\*) Standard hardware item, available locally.





## PALMGREN WARRANTY

C.H. Hanson / Palmgren warrants their products to be free of defects in material or workmanship. This warranty does not cover defects due directly or indirectly to misuse, abuse, normal wear and tear, failure to properly maintain the product, heated, ground or otherwise altered, or used for a purpose other than that for which it was intended.

The warranty does not cover expendable and/or wear part (i.e. v-belts, screws, abrasives, jaws), damage to tools arising from alteration, abuse or use other than their intended purpose, packing and freight. The duration of this warranty is expressly limited to the terms noted below beginning from the date of delivery to the original user.

**The Palmgren branded items carry the following warranties on parts:**

**All arbor presses, vises, clamps, positioning tables, tombstones, jack screws and vise accessories - LIFETIME.**

**All bench grinders, drill presses, tapping machines, band saws, lathes, milling machines, abrasive finishing machines and work stands - 3 YEARS.**

The obligation of C.H. Hanson / Palmgren is limited solely to the repair or replacement, at our option, at its factory or authorized repair agent of any part that should prove inoperable. Purchaser must lubricate and maintain the product under normal operating conditions at all times. Prior to operation become familiar with product and the included materials, i.e. warnings, cautions and manuals.

**Failure to follow these instructions will void the warranty.**

This warranty is the purchaser's exclusive remedy against C.H. Hanson for any inoperable parts in its product. Under no circumstances is C.H. Hanson liable for any direct, indirect, incidental, special or consequential damages including loss of profits in any way related to the use or inability to use our products. This warranty gives you specific legal rights which may vary from state to state.

# PALMGREN®

**Palmgren - a C.H. Hanson Company**  
**2000 N. Aurora Rd., Naperville, IL 60563 U.S.A.**  
**or call 1-800-827-3398**