



PALMGREN®

7" × 12" METAL CUTTING BAND SAW



Read carefully and follow all safety rules and operating instructions before first use of this product.



DESCRIPTION

Palmgren 7 x 12" Horizontal Metal Cutting Band Saw provides speed with quality of cut for fabrication shops, machine shops, maintenance departments and contractors. Blade speed ranges from 86 to 260 FPM to cut a variety of material ranging from cast iron, tool steel, bronze, aluminum and plastic.

The feed rate is regulated by a hydraulic cylinder. The dial control for the cylinder is accessible during all stages of proper operation and can be set at any feed rate within its range. The wet cut operation provides a quality cut and extends blade life. Features include automatic shutoff, industrial rated speed reducer, heavy gauge steel construction, cast iron wheels, pulleys, head and bed.

Additional features include swivel vise jaws for angle cuts, built in chip tray and wheel assemblies. Saw is controlled by magnetic switch.

UNPACKING

Refer to Figure 1.

Check for shipping damage. If damage has occurred, a claim must be filed with carrier immediately. Check for completeness. Immediately report missing parts to dealer.

The band saw comes completely assembled as one unit. Additional parts which need to be fastened to the saw should be located and accounted for before assembling:

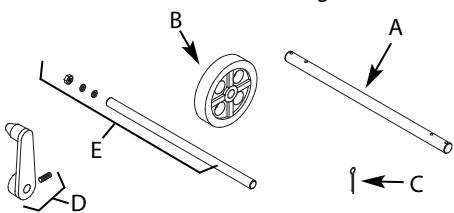

Figure 1 - Unpacking

- A Axle (2)
- B Wheel (4)
- C Cotter Pin (8)
- D Work Stop with set screw
- E Work Stop rod with hex nut and two lock washers

WARNING: Be careful not to touch overhead power lines, piping, lighting, etc. if lifting equipment is used. Band Saw weighs approximately 318 lbs. proper tools, equipment and qualified personnel should be employed in all phases of unpacking and installation.

IMPORTANT: Bed is coated with a protectant. To ensure proper fit and operation, remove coating. Coating is easily removed with mild solvents, such as mineral spirits, and a soft cloth. Avoid getting cleaning solution on paint or any of the rubber or plastic parts. Solvents may deteriorate these finishes. Use soap and water on paint, plastic or rubber components. After cleaning, cover all exposed surfaces with a light coating of oil.

WARNING: Never use highly volatile solvents. Non-flammable solvents are recommended to avoid possible fire hazard.

SPECIFICATIONS

Capacity	7" Rounds
	4" Rounds at 45°
	7 x 12" Rectangle at 90°
	4 x 7" Rectangle at 45°
Motor	1 HP, 1725 RPM, 120/240 Volts, 9/4.5 Amps, 60 Hz

Blade speeds	86, 132, 178 and 260 FPM
Blade size	3/4 x .032 x 93"
Blade wheels	11½" Diameter, cast iron
Overall dimensions	45 x 18 x 41"
Crate dimensions	49.6 x 18.1 x 42.5"
Weight	318 lb
Shipping weight	385 lb
Coolant pump	2.2 Gallons per minute
Coolant reservoir capacity	3.5 Gallons

SAFETY RULES

WARNING: For your own safety, read operating instructions manual before operating tool.

PROPOSITION 65 WARNING: Some dust created by using power tools contain chemicals known to the state of California to cause cancer, birth defects or other reproductive harm.

Some examples of these chemicals are:

- Lead from lead-based paints
- Crystalline silica from bricks and cement and other masonry products.
- Arsenic and chromium from chemically treated lumber.

Your risk from these exposures varies, depending on how often you do this type of work. To reduce your exposure to these chemicals; work in a well ventilated area and work with approved safety equipment. Always wear **OSHA/NIOSH** approved, properly fitting face mask or respirator when using such tools.

WARNING: Always follow proper operating procedures as defined in this manual even if you are familiar with the use of this or similar tools. Remember that being careless for even a fraction of a second can result in severe personal injury.

BE PREPARED FOR JOB

- Wear proper apparel. Do not wear loose clothing, gloves, neckties, rings, bracelets or other jewelry which may get caught in moving parts of machine.
- Wear protective hair covering to contain long hair.
- Wear safety shoes with non-slip soles.
- Wear safety glasses complying with United States ANSI Z87.1. Everyday glasses have only impact resistant lenses. They are **NOT** safety glasses.
- Wear face mask or dust mask if operation is dusty.
- Be alert and think clearly. Never operate power tools when tired, intoxicated or when taking medications that cause drowsiness.

PREPARE WORK AREA FOR JOB

- Keep work area clean. Cluttered work areas invite accidents.
- Do not use power tools in dangerous environments. Do not use power tools in damp or wet locations. Do not expose power tools to rain.
- Work area should be properly lighted.
- Proper electrical receptacle should be available for tool. Plug 120 volt, single-phase plug directly into properly grounded, three-prong receptacle.
- Extension cords should have a grounding prong and the three wires of the extension cord should be of the correct gauge.
- Keep visitors at a safe distance from work area.
- Keep children out of workplace. Make workshop childproof. Use padlocks or master switches to prevent any unintentional use of power tools.

SAFETY RULES (CONTINUED)**TOOL SHOULD BE MAINTAINED**

- Always unplug tool prior to inspection.
- Consult manual for specific maintaining and adjusting procedures.
- Keep tool lubricated and clean for safest operation.
- Remove adjusting tools. Form habit of checking to see that adjusting tools are removed before switching machine on.
- Keep all parts in working order. Check to determine that the guard or other parts will operate properly and perform their intended function.
- Check for damaged parts. Check for alignment of moving parts, binding, breakage, mounting and any other condition that may affect a tool's operation.
- A guard or other part that is damaged should be properly repaired or replaced. Do not perform makeshift repairs. (Use parts list provided to order repair parts.)

KNOW HOW TO USE TOOL

- Use right tool for job. Do not force tool or attachment to do a job for which it was not designed.
- Unplug tool when changing blade.
- Avoid accidental start-up. Make sure that the tool is in the OFF position before plugging in.
- Do not force tool. It will work most efficiently at the rate for which it was designed.
- Keep hands away from moving parts and cutting surfaces.
- Never leave tool running unattended. Turn the power off and do not leave tool until it comes to a complete stop.
- Do not overreach. Keep proper footing and balance.
- Never stand on tool. Serious injury could occur if tool is tipped or if blade is unintentionally contacted.
- Know your tool. Learn the tool's operation, application and specific limitations.
- Use recommended accessories. Use of improper accessories may cause risk of injury to persons.
- Handle workpiece correctly. Protect hands from possible injury.
- Turn machine off if it jams. Blade jams when it digs too deeply into workpiece. (Motor force keeps it stuck in the work.) Do not remove jammed or cut off pieces until the saw is turned off, unplugged and the blade has stopped.

CAUTION: Think safety! Safety is a combination of operator common sense and alertness at all times when tool is being used.

ASSEMBLY

WARNING: Do not attempt to operate tool until it is completely assembled according to the instructions.

ATTACH WHEEL ASSEMBLIES

Refer to figure 9.

1. Raise and prop up right leg (Ref. No. 3) approximately 3". Support saw on leg only. Do not use shelf to support saw. Slide axle (Ref. No. 35) through holes in leg.
2. Insert cotter pin (Ref. No. 36) into inner hole of axle. Bend end of cotter pin back to secure in place. Slide wheel (Ref. No. 34) onto axle. Insert cotter pin into outer hole of axle and bend end of cotter pin back to secure in place.
3. Repeat step 2 for other end of axle.
4. Repeat steps 1, 2 and 3 for left leg.

ATTACH FILTER AND RETURN HOSE

Refer to figure 9.

1. Place filter assembly (Ref. No. 44) into center drain of chip tray (Ref. No. 1).

ATTACH WORK STOP

Refer to figure 9.

1. Insert work stop rod (Ref. Nos. 74) into bed. Secure rod in position with hex bolt.
2. Attach work stop (Ref. Nos. 73) to rod and secure in position with set screw (Ref. No. 72).

INSTALLATION

Refer to Figures 2 and 3.

CAUTION: Do not attempt installation if parts are missing. Use this manual to order repair parts.

Before band saw is installed, a suitable location should be chosen. Band saw weighs approximately 318 lbs.

- Band saw needs to be set on a flat, level surface.
- Make sure there is ample room for the workpiece.
- Good lighting and correct power supply are also required for a proper work area.

POWER SOURCE

Band saw is prewired for 120 volt, 60 Hz power source.

WARNING: All electrical connections must be performed by a qualified electrician.

WARNING: Do not connect band saw to the power source until all assembly steps have been completed.

The motor is designed for operation on the voltage and frequency specified. Normal loads will be handled safely on voltages not more than 10% above or below the specified voltage.

Running the unit on voltages which are not within the range may cause overheating and motor burn-out. Heavy loads require that the voltage at motor terminals be no less than the voltage specified.

Band saw is prewired to operate at 120 volts.

GROUNDING INSTRUCTIONS

WARNING: Improper connection of equipment grounding conductor can result in the risk of electrical shock. Equipment should be grounded while in use to protect operator from electrical shock.

Check with a qualified electrician if you do not understand grounding instructions or if in doubt as to whether the tool is properly grounded.

This tool is equipped with an approved cord rated at 250V and a 3-prong grounding type plug rated at 125V (See Figure 2) for your protection against shock hazards.

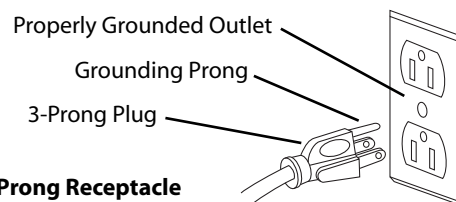

Figure 2 – 3-Prong Receptacle

Grounding plug should be plugged directly into a properly installed and grounded 3-prong grounding-type receptacle, as shown in Figure 2.

Do not remove or alter grounding prong in any manner. In the event of a malfunction or breakdown, grounding provides a path of least resistance for electrical shock.

INSTALLATION (CONTINUED)

WARNING: Do not permit fingers to touch the terminals of plug when installing or removing from outlet.

Plug must be plugged into matching outlet that is properly installed and grounded in accordance with all local codes and ordinances. Do not modify plug provided. If it will not fit in outlet, have proper outlet installed by a qualified electrician.

Inspect tool cords periodically, and if damaged, have repaired by an authorized service facility.

Green (or green and yellow) conductor in cord is the grounding wire. If repair or replacement of the electric cord or plug is necessary, do not connect the green (or green and yellow) wire to a live terminal.

Where a 2-prong wall receptacle is encountered, it must be replaced with a properly grounded 3-prong receptacle installed in accordance with National Electric Code and local codes and ordinances.

WARNING: This work should be performed by a qualified electrician.

A temporary 3-prong to 2-prong grounding adapter (See Figure 3) is available for connecting plugs to a two pole outlet if it is properly grounded.

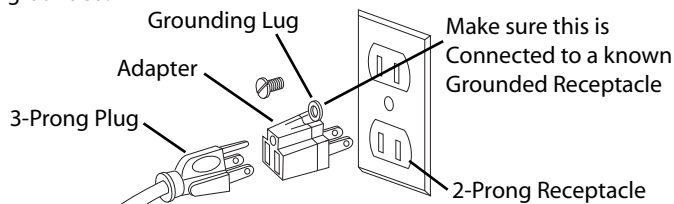

Figure 3 – 2-Prong Receptacle with Adapter

Do not use a 3-prong to 2-prong grounding adapter unless permitted by local and national codes and ordinances.

(A 3-prong to 2-prong grounding adapter is not permitted in Canada.) Where permitted, the rigid green tab or terminal on the side of the adapter must be securely connected to a permanent electrical ground such as a properly grounded water pipe, a properly grounded outlet box or a properly grounded wire system.

Many cover plate screws, water pipes and outlet boxes are not properly grounded. To ensure proper ground, grounding means must be tested by a qualified electrician.

EXTENSION CORDS

- The use of any extension cord will cause some drop in voltage and loss of power.
- Wires of the extension cord must be of sufficient size to carry the current and maintain adequate voltage.
- Running the unit on voltages which are not within $\pm 10\%$ of the specified voltage may cause overheating and motor burn-out.
- Use the table to determine the minimum wire size (A.W.G.) extension cord.
- Use only 3-wire extension cords having 3-prong grounding type plugs and 3-pole receptacles which accept the tool plug.
- If the extension cord is worn, cut or damaged in any way, replace it immediately.

Extension Cord Table						
		Volts	Total Length of Cord in Feet			
Ampere Rating		120	25	50	100	150
More Than	Not More Than	240	50	100	150	300
			Minimum Gage for Cord			
0	6		18	16	16	14
6	10		18	16	14	12
10	12		16	16	14	12
12	16		14	12	Not Recommended	

OPERATION

Refer to Figures 4-10.

The 7 × 12", 4-speed horizontal band saw blade speeds range from 86 to 260 FPM.

Vise jaws can turn 0 – 45° for making angle cuts. Movable jaw has rapid approach and withdraw capability.

WARNING: Always observe the following safety precautions.

- Whenever adjusting or replacing any parts on the band saw turn switch off and remove plug from power source.
- Make sure the stops are positioned and that the automatic shut-off is operating.
- Check that the gear box has the proper amount of lubricant.
- Make sure the blade guides are positioned correctly.
- Use the appropriate blade for the workpiece that is being cut.
- Use a sharp blade. Replace dull blades or blades which are missing teeth.
- Make sure the blade is tensioned properly and going in the right direction.
- Use the proper blade speed for the work.
- For optimum performance, do not stall the motor or reduce the speed. Use the proper feed pressure.
- Make sure enough coolant is available to keep coolant pump (Figure 9, Ref. No. 103) submerged.
- Secure the workpiece in a stable position.
- Check that all guards are attached.
- After turning the switch on, let the blade come to full speed. Then lower the blade onto the workpiece slowly.
- Keep hands away from the blade and all moving parts.
- Always wear eye protection.

HORIZONTAL STOP

Refer to Figure 9.

Horizontal stop (Ref. No. 60) controls the position of the head at the end of the cut. Head should contact the horizontal stop when teeth are 1/8" below the surface of the workbed.

HORIZONTAL STOP ADJUSTMENT

Refer to Figure 9.

1. Place head in the horizontal position.
2. Loosen the nuts (Ref. No. 61) on the horizontal stop.
3. Adjust the horizontal stop so that the teeth are 1/8" below the surface of the workbed.
4. Tighten nuts to lock the position.

LUBRICATION

- All ball bearings are permanently lubricated. They should not require further lubrication.
- If the tracking wheel or head pivot is disassembled for any reason, wipe off the old grease before assembly.

OPERATION (CONTINUED)**OIL LEVEL**

Refer to Figure 10.

- The gear box relies on an oil bath to lubricate the sliding surfaces and transfer heat. The vent bolt (Ref. No. 113) is vented to release pressure created by the developed heat. Insufficient lubrication will cause the gears to heat up and wear at an accelerated rate. If the gear box is overfilled, hot oil will escape through the vent hole. The gear box is designed to take 10 ounces of 70-95 weight industrial gear oil.
- The oil level should remain constant. If the level changes, a defective gasket or seal should be looked for and replaced.
- If the gear box is worked on, the oil should be replaced to avoid contamination.
- Always add fresh oil and replace the oil seasonally, to guard against breakdown.
- The seal between the gearbox and the cover plate is a gasket (Ref. No. 115N). If cover plate is removed, the surface should be cleaned and a new gasket should be applied.
- After the first fifty hours of use, the gear box should be drained and refilled with industrial gear oil.

BLADE GUIDES

Band saw blade has to be twisted relative to the plane in which it rotates. Blade must be properly positioned relative to the workbed.

Blade guides hold the cutting portion of the blade in a plane which is perpendicular to both the workbed and the stationary vise and keeps the blade in line with its natural path around the blade wheels.

Inner guide bearings on the left and right guide assemblies keep the blade in line with the blade wheels. Outer guide bearings keep the blade against the inner bearings.

Entire guide assembly is positioned at the factory to produce the proper twist and should not need adjustment, however, the position of blade guides should be checked often.

NOTE: Since the blade position is related to both bed and the vise jaws, the relative position of the jaw to the bed is important. When assembled, the stationary jaw must be perpendicular to the surface of the workbed.

CHECKING BLADE GUIDES

Refer to Figure 10.

1. Check that the blade teeth are perpendicular to the machined surface of the base.
2. Spread the blade guides as far apart as possible.
3. Check that vise jaws are parallel and set for 90° cutoff.
4. Position the vise jaws to have the maximum separation that will not interfere with the blade guides.
5. With the head in horizontal position, use a square against face of rear vise jaw and check that jaw is 90° to the side of blade.
6. Check that the blade is in line with tracking and drive wheels (Ref. Nos. 175 and 124).
7. Raise the head.
8. Look straight on at the cutting edge of the blade.
9. Make sure that the blade sides are parallel to the sides of the bearings.
10. Make sure the bearings (Ref. No. 133) touch the blades and can still be rotated by hand.

ADJUSTING GUIDE BEARINGS

Refer to Figure 10.

If the blade is not perpendicular to the bed or not in line with the blade wheels, adjustment is necessary.

NOTE: There should be .000-.001" clearance between the blade and the guide bearings.

The guide bearings are adjusted using an eccentric location system. The inner guide bearings are fixed and cannot be adjusted. The outer guide bearings are mounted to eccentric shafts (Ref. No. 136) and can be adjusted.

1. Loosen hex nuts (Ref. No. 137) with a wrench. Rotate the eccentric shaft to locate bearings in desired positions.
2. Maintain eccentric shaft position and tighten hex nuts.

CHECKING THRUST BEARINGS

Refer to Figure 10.

The thrust bearings (Ref. No. 133) should be .003-.005" (average thickness of a piece of paper) away from back of blade.

The thrust bearings are adjusted by moving the guide bracket.

ADJUSTING GUIDE BRACKETS

Refer to Figure 10.

If the bearings are positioned properly and the blade is not square, one or both blade guide brackets (Ref. Nos. 163 and 132) must be adjusted.

1. Loosen the socket head bolts (Ref. No. 161).
2. Adjust the bracket to the correct position.
3. Tighten the socket head bolts.
4. Check the guide bearings. Repositioning the blade guide bracket can alter the previous adjustments. Readjust if necessary.

BLADE SELECTION

Using the proper blade is important for setting up the correct cutting conditions. Blades are made differently depending on the specific application intended for the blade. Some simple rules can still be applied to almost all blades.

- Always remember to have at least three teeth in contact with the work during a cut. When three teeth are in contact, the blade cannot straddle the work. This prevents a tooth that enters the cut from encountering more material than it can remove.
- "Shocking" occurs when blade teeth contact too much material. This can strip the teeth from the blade. When cutting harder materials, the suggested minimum number of teeth in contact is six because "shocking" on harder materials has a more detrimental effect on the blade. Optimum number of teeth in contact with workpiece distributes blade forces among more teeth to increase cutting efficiency and reduces blade wear.
- Optimum range is from 6 – 12 teeth in contact for soft materials, up to 12 – 24 teeth in contact for harder materials.
- Always have maximum number of teeth in contact with work to prevent gullets of teeth from being clogged.
- When choosing a blade, overall size of the work is not as important as the thickness average. Thickness average is the average width of material which blade will contact during each cut. Figure 8, page 8 describes how thickness average should be calculated.

OPERATION (CONTINUED)

- Thickness average should be used when choosing a blade for the optimum number of teeth in contact, however, the three teeth rule should be applied to the minimum thickness, not thickness average.
- Keeping a selection of sharp blades on hand will yield better cuts. Blades may last longer because they are less likely to be misused when proper blade is available.
- Every band saw should have at least one replacement blade of each type used. Blade breakage is unpredictable. Consult a blade manufacturer for detailed information about available blades for specific uses.

REMOVING BLADE

Refer to Figure 10.

WARNING: Disconnect band saw from power source when changing or adjusting blades. Wear leather gloves when handling band saw blades. Never wear gloves when operating saw.

1. Raise the head and open the blade cover.
2. Loosen the outer guide bearings on the upper and lower guide assemblies. No other guide bearings should be moved.
3. With one hand, pinch the blade and the tracking wheel together to protect against the possibility of the blade popping off when tension is released.
4. Release the tension by slowly revolving the knob (Ref. No. 181) counterclockwise.
5. Remove the blade.

REPLACING THE BLADE

1. Make sure the outer guide bearings are loose.
2. Make sure the teeth are pointing in the right direction (See Figure 4).

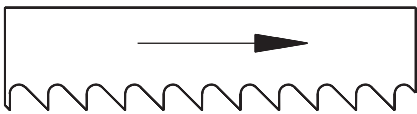

Figure 4 – Blade Direction

3. Place the blade around the wheels and between the guide bearings.
4. Hold the blade in position and apply tension.
5. Push the blade against the wheel flange.
6. Tighten the blade until it is properly tensioned. A properly tightened blade will ring slightly when the back of the blade is plucked (like a string of an instrument).
7. Adjust the outer guide bearings.
8. Check for proper tracking (See Tracking Adjustment).

TRACKING

Proper tracking is achieved when the drive wheel and tracking wheel are aligned. A blade that is not tracking correctly can come off the blade wheels. Although adjustment is rarely required, tracking should be checked frequently.

CAUTION: Turn motor off and disconnect power to check tracking.

CHECK TRACKING

Refer to Figures 5 and 10.

1. Raise the head. Open the wheel cover.
2. Insert a piece of paper between the blade and the left side of the idler wheel.
3. Let the blade grab the paper. Rotate the tracking wheel (Figure

10, Ref. No. 175) so the paper goes around the wheel.

4. Refer to Figure 5 to determine if an adjustment is needed.

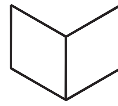

A sharp fold indicates proper tracking.

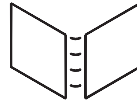

Cut or ripped paper indicates that the blade is riding against the flange of the wheel. Adjusting set screw needs to be turned counterclockwise.

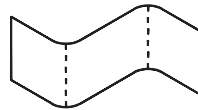

No fold indicates the blade will ride off the wheel. Adjusting set screw should be turned clockwise.

Figure 5 – Tracking Adjustments

TRACKING ADJUSTMENT

Refer to Figures 5 and 10.

The tracking is adjusted by positioning the tracking wheel shaft (Ref. No. 171). The positioning is done with the set screw (Ref. No. 167).

1. Loosen the two socket head bolts.
2. Adjust the tilt with set screws. For correct tracking, refer to Figure 5. Turn 1/4 revolution at a time.
3. Check the blade tension and adjust if necessary.
4. Recheck the tracking.
5. Once the proper position has been found, tighten the bolts securely.

BLADE SPEED

Choosing the proper blade speed is important for extending the life of the blade. The speed determines the available cutting force.

- Harder materials require more force and are cut at a slower speed.
- Softer materials are cut with less force at higher speeds to ensure the proper removal of the chips.
- The speed and corresponding force are related to the power supplied to the blade. Four speeds are available.
- If a motor, other than the one supplied is used, the cutting speeds will be changed.
- Speeds and corresponding materials are listed below.

FPM

86	Stainless steel, alloy steel
132	Medium to high carbon steels, hard brass
178	Low to medium carbon steels, copper
260	Aluminum, plastics

OPERATION (CONTINUED)**CHANGING SPEEDS**

Refer to Figures 6 and 10.

1. Loosen screw (Ref.No. 190) and open pulley cover (Ref.No. 189).
2. Loosen hex nut (Ref.No. 152) and turn hex head bolt (Ref.No. 151) counterclockwise to loosen belt tension.
3. Move V-belt (Ref.No. 183 to desired position on pulleys (Ref.Nos. 185 and 184).
4. Turn hex head bolt clockwise to tension belt. Belt is tensioned properly when a moderate pressure applied to the belt between the pulleys produces $\frac{1}{2}$ " of deflection. Tighten hex nut to secure belt tension.
5. Close and secure pulley cover.

FEED PRESSURE

- Correct feed pressure holds the blade in the cut. Feed pressure is supplied by the weight of the head. Maximum material removal rate corresponds with the proper pressure.
- Optimum feed pressure ensures that maximum power is used for cutting. If the feed pressure is too low, the blade will not dig into the material properly. Too much feed pressure will cause the blade to dig too deeply, bogging down the motor, and possibly burning it out. In addition, blade "shocking" could result.
- Extra energy will be used to produce powdered chips rather than smooth shavings; this will produce more heat and dull the blade.

CAUTION: Do not attempt to increase feed pressure by leaning on head.

REGULATING FEED PRESSURE

Refer to Figures 7 and 9.

- Feed pressure is controlled by the feed regulator. The regulator creates a force which counteracts the feed pressure. The force from the feed regulator can be adjusted to create any feed pressure up to the set maximum.
- Having the correct feed pressure will produce the optimum feed rate and the fastest cut. Incorrect pressure, whether too great or too small, will put less power into the cut and reduce the feed rate.

NOTE: Wasted power damages the saw.

- Determining the proper feed is largely a judgement based on experience. The feed is usually determined during the cutting operation. Before the cutting begins, the blade should be off the work and the head should be held in position by closing the knob on the feed regulator (Figure 9, Ref. No. 20).
- Once the blade is running, the head is slowly lowered onto the work by adjusting knob on the feed regulator.

- After the blade begins the cut, optimum feed rate should be determined.
- To determine if the feed is incorrect, examine the chips produced. When the blade is operating at the ideal feed for the speed, the chips will be curled and continuous. If the chips are thick and not continuous, the feed pressure should be reduced. If the chips are powdery, the feed pressure needs to be increased (Refer to Figure 7).



Curled shavings indicate correct feed pressure.

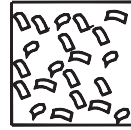

Thick discontinuous chips indicate too much pressure. Turn knob clockwise.

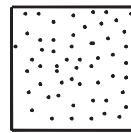

Powdery chips indicate too little pressure. Turn knob counterclockwise.

Figure 7 – Determine Feed Pressure

CUTTING FLUIDS

- Using a cutting fluid can improve the cutting conditions and keep them more consistent throughout the cut by:
 - a. Lubricating the blade, which reduces the friction between it and the workpiece.
 - b. Taking heat away from the cut and preventing the workpiece and blade from overheating.
 - c. Dissipating the built-up heat because hot metals become tough and more difficult to cut and blades become dull at an accelerated rate.

NOTE: Because much of the built-up heat comes from friction between the blade and the workpiece, cutting fluids are often referred to as "coolants".

- The importance of cutting fluids increases with blade speed and toughness of the material.
- There are many available types of cutting fluids. Consult a machinery handbook for specific information. The most common general purpose coolant is a mixture of water and water soluble oil. The producer of the water soluble oil should provide the appropriate mixing ratios.

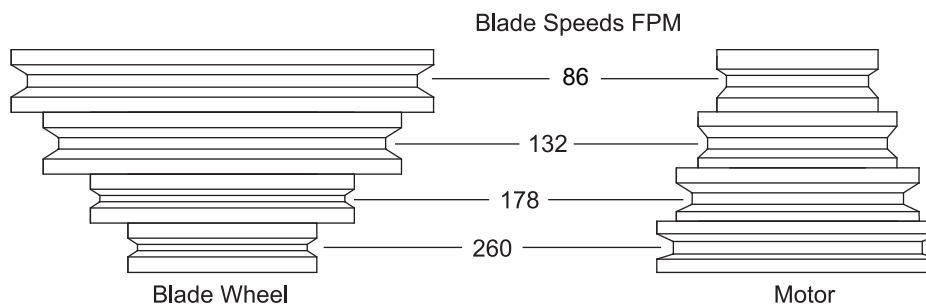

Figure 6 - Speed and Pulley Diagram

OPERATION (CONTINUED)**COOLANT TANK**

Refer to Figure 9.

- The coolant tank (Ref. No. 107) can hold up to 2.25 gallons of coolant. For proper operation, the pump must be completely submerged in fluid.
- Check that the fluid level is sufficient before attempting wet-cut operations. Usually two gallons is sufficient.
- Check that the tank is not filled with debris.

CAUTION: Do not allow shavings to flow through the pump. Change the fluid and clean the tank often. Whenever possible, the chips should be cleaned out of the chip tray (Ref. No. 1) before they are washed into coolant reservoir.

POSITIONING

Refer to Figure 8.

The vise is designed to keep the workpiece steady while it is being cut. The vise should only have to counteract the cutting forces. Using the proper position will help produce a safe and accurate cut. These general rules about positioning apply to most situations:

- The workpiece should rest flat on the workbed without the need for side support. Some suggested configurations are shown in Figure 8.
- The entire length of the work should be supported. Do not balance the workpiece on the workbed. Use support stands to prevent the work from falling off after the cut.
- Avoid positions which will cause the blade to encounter sharp edges. If sharp corners cannot be avoided, file down the point that the blade will contact.

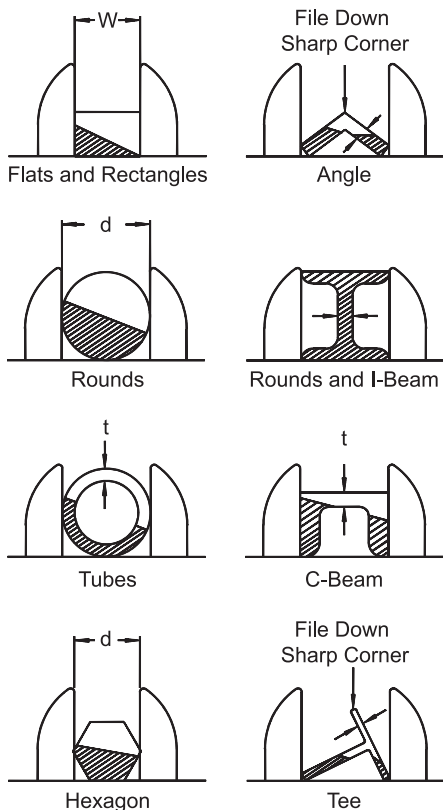

Figure 8 – Clamping Configurations and Thickness Average Calculation

WORK STOP ADJUSTMENT

Refer to Figures 8 and 9.

1. Loosen the screw (Ref. No. 72) holding the work stop (Ref. No. 73) to the work stop rod (Ref. No. 74).
 2. Adjust the work stop casting to the desired length position.
 3. Rotate the work stop to contact the workpiece as close to the bottom as possible.
 4. Tighten the wing bolt.
- Do not allow the blade to rest on the workpiece while the motor is shut off.
 - Flats and rectangles have thickness averages of w (See Figure 8).
 - Rounds and many sided regular cross-sections have thickness average of $0.75d$.
 - Tubes and structural shapes have a thickness average of $2.5t$.

NOTE: See Blade Selection for more information on thickness average calculation.

CHECK THE BLADE PATH

Before the saw is plugged in, check to see that blade path is clear and that:

- All blade guards are in place.
- There is no debris inside the blade guard or covers.
- There is no debris on the blade or blade wheels.
- All hoses and line cords are out of the blade path.

WARNING: Do not operate saw unless all guards are in place and the workpiece is the only object that will encounter the blade teeth.

MAINTENANCE

Refer to Figure 9.

Steps required to keep the saw in optimum operating condition have been described under Operation. The Safety Precautions should be performed before operation.

For proper maintenance:

- Keep saw clean and dry. Sweep off spots where chips have collected and wipe off spots where coolant splashed.
- Lubricate the unpainted surfaces with a light application of medium consistency machine oil to prevent corrosion after cleaning.
- Grease the vise lead screw (Ref. No. 50) if vise action becomes difficult.
- Replace dull blades and blades from which teeth have been stripped. A clean saw with a sharp blade will yield the best cut.
- Internal parts of the band saw have been completely lubricated at the factory and do not need to be relubricated.
- After the first fifty hours of use, the gear box should be drained and refilled.

WARNING: Make certain unit is disconnected from power source before attempting to service or remove any component. If power cord is worn, cut, or damaged in any way, have it replaced immediately by a qualified electrician.

**TROUBLESHOOTING**

SYMPTOM	POSSIBLE CAUSES	CORRECTIVE ACTION
Blade cuts (crooked)	<ol style="list-style-type: none"> 1. Work not square 2. Feed pressure too great 3. Guide bearings not adjusted properly 4. Inadequate blade tension 5. Blade guides spaced out too much 6. Dull blade 7. Speed incorrect 8. Blade guide assembly loose 9. Blade guide bearing assembly loose 10. Blade tracks too far away from wheel flanges 11. Guide bearing worn 	<ol style="list-style-type: none"> 1. Adjust vise to be square with blade 2. Reduce pressure by increasing spring tension 3. Adjust guide bearings 4. Increase blade tension a little at a time 5. Move guides as close to work as possible 6. Replace blade 7. Check page 6 for recommended speeds 8. Tighten 9. Tighten 10. Track blade properly according to instructions under Operation, pages 6 11. Replace
Bad cuts (rough)	<ol style="list-style-type: none"> 1. Too much speed or feed 2. Blade has too few teeth per inch 	<ol style="list-style-type: none"> 1. Reduce speed or feed 2. Replace with finer tooth blade
Blade is twisting Unusual wear on side or back of blade	<ol style="list-style-type: none"> 1. Cut is binding blade 2. Blade guides worn 3. Blade guide bearings not adjusted properly 4. Blade guide bearings not adjusted properly 5. Feed pressure too great 	<ol style="list-style-type: none"> 1. Decrease feed pressure 2. Replace 3. Adjust guide bearings (see page 5) 4. Tighten bearings 5. Reduce feed pressure
Motor will not start	<ol style="list-style-type: none"> 1. No electrical power to motor 2. Low voltage 3. Defective On/Off switch; defective line cord 4. Open circuit in motor or loose connections 5. Motor protector open (only if your motor is equipped with an overload protector) 6. Burned out motor 7. Limit switch closed 	<ol style="list-style-type: none"> 1. Check electrical wiring to motor for continuity 2. Check power line for proper voltage 3. Replace defective parts before using band saw again 4. Inspect lead terminals on motor for loose or open connections 5. Reset protector after motor has cooled 6. Replace motor 7. Raise head to open limit switch
Motor will not start; fuses or circuit breakers blow	<ol style="list-style-type: none"> 1. Short circuit in line cord or plug 2. Short circuit in motor or loose connection 3. Incorrect fuses or circuit breakers in power line 4. Motor overloaded 	<ol style="list-style-type: none"> 1. Inspect line cord or plug for damaged insulation and shorted wires 2. Inspect all lead terminals on motor for loose or worn insulation on wires 3. Install correct fuses or circuit breakers 4. Reduce load on motor
Motor fails to develop full power (power output of motor decreases rapidly) with decreased voltage at motor terminals	<ol style="list-style-type: none"> 1. Power line overloaded 2. Undersized wires or cords too long 3. General overloading of power company's facilities 	<ol style="list-style-type: none"> 1. Reduce the load on the power line 2. Increase wire sizes or reduce length of cords 3. Request a voltage check from the power company





TROUBLESHOOTING

SYMPTOM	POSSIBLE CAUSES	CORRECTIVE ACTION
Motor overheats	<ol style="list-style-type: none"> 1. Motor overloaded 2. Air circulation around motor restricted 	<ol style="list-style-type: none"> 1. Reduce load on motor 2. Clean motor to provide normal air circulation around motor
Motor stalls (resulting in blown fuses or tripped circuit breakers)	<ol style="list-style-type: none"> 1. Short circuit in motor; connections loose; or shorted terminals or worn insulation on lead wires 2. Low voltage 3. Incorrect fuses or circuit breakers 4. Motor overloaded 	<ol style="list-style-type: none"> 1. Inspect terminals in motor for damaged insulation and shorted wires 2. Correct the low line voltage conditions 3. Install correct fuses or circuit breakers 4. Reduce load on motor
Frequent opening of fuses or circuit breakers	<ol style="list-style-type: none"> 1. Motor overloaded 2. Incorrect fuses or circuit breakers 	<ol style="list-style-type: none"> 1. Reduce load on motor 2. Install correct fuses or circuit breakers
Motor problems in general	Various causes	To troubleshoot and service motor consult qualified technician
Teeth ripping from blade	<ol style="list-style-type: none"> 1. Teeth too coarse for work 2. Too heavy feed 3. Too slow speed 4. Vibrating workpiece 5. Gullets loaded 	<ol style="list-style-type: none"> 1. Use finer tooth blade 2. Decrease feed pressure 3. Increase speed 4. Clamp work securely 5. Use coarse tooth blade or use brush to remove chips
Motor running too hot	<ol style="list-style-type: none"> 1. Blade tension too high 2. Blade too coarse for work (pipes especially) 3. Blade too fine for work (heavier, soft material) 4. Gears need lubrication 	<ol style="list-style-type: none"> 1. Reduce tension on blade 2. Use finer tooth blade 3. Use coarser tooth blade 4. Check oil bath
Coolant does not flow	<ol style="list-style-type: none"> 1. Pump motor burned out 2. Dirty screen/filter on pump 3. Coolant level too low 	<ol style="list-style-type: none"> 1. Replace pump 2. Clean 3. Refill coolant tank
Excessive blade breakage	<ol style="list-style-type: none"> 1. Material loose in vise 2. Incorrect speed or feed 3. Teeth too coarse for material 4. Incorrect blade tension 5. Teeth in contact with work before saw is started 6. Blade rubs on wheel flange 7. Misaligned guides 8. Blade too thick for wheel diameter 	<ol style="list-style-type: none"> 1. Clamp work securely 2. Check Machinist Handbook 3. Check Machinist Handbook for recommended blade type 4. Adjust to where blade does not slip on wheel 5. Place blade in contact with work after motor is started 6. Adjust tracking 7. Adjust guide bearings 8. Use thinner blade
Premature blade dulling	<ol style="list-style-type: none"> 1. Teeth too coarse 2. Too much speed 3. Inadequate feed pressure 4. Hard spots or scale in/on material 5. Work hardening of material (especially stainless steel) 6. Blade installed backwards 7. Insufficient blade tension 	<ol style="list-style-type: none"> 1. Use finer tooth blade 2. Try next lower speed 3. Decrease spring pressure 4. Reduce speed, increase feed of saw 5. Increase feed pressure by reducing spring tension 6. Remove blade, twist inside out and reinstall blade 7. Increase tension to proper level



REPAIR PARTS ILLUSTRATION FOR BAND SAW

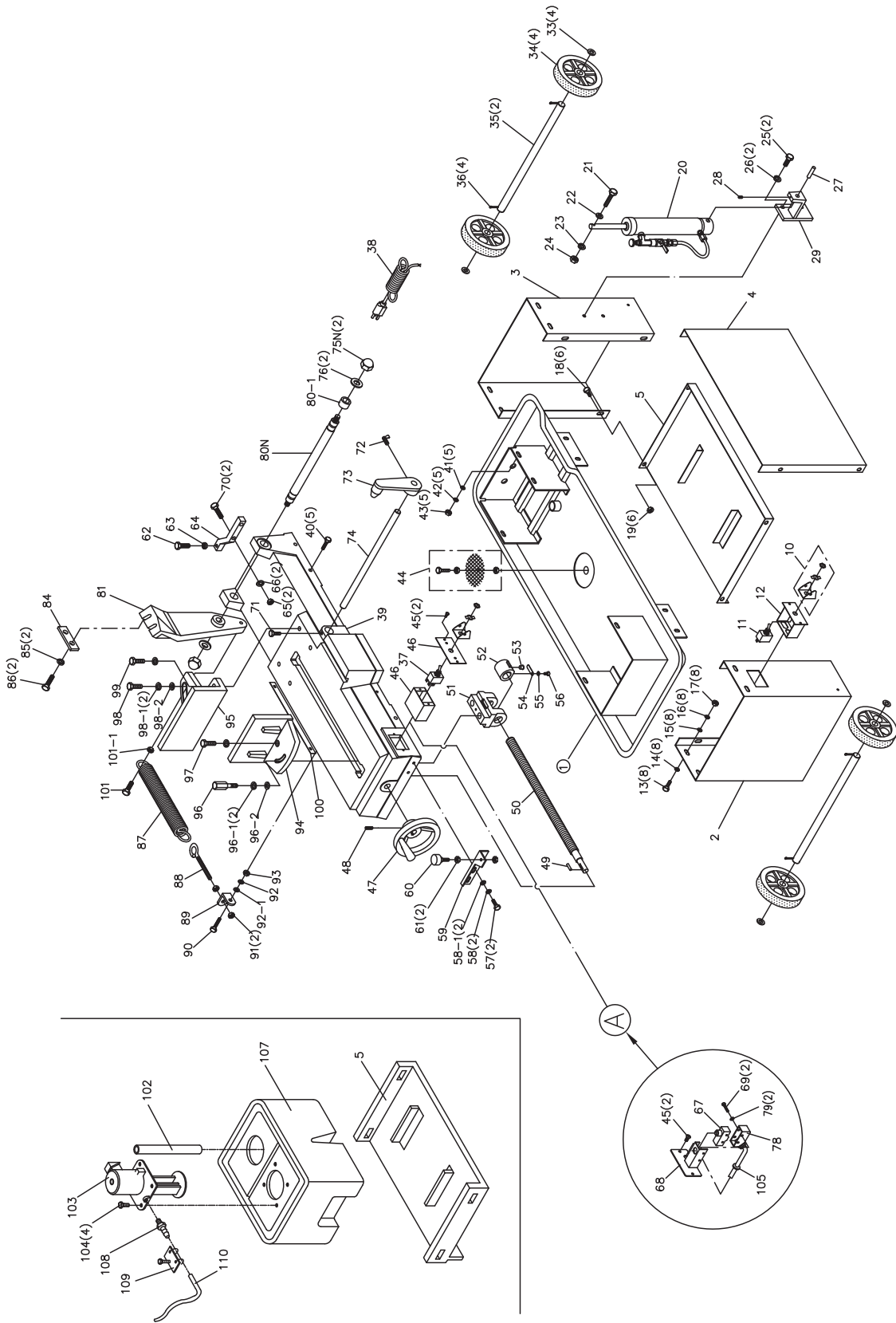

Figure 9 — Replacement Parts Illustration

REPAIR PARTS ILLUSTRATION FOR BAND SAW

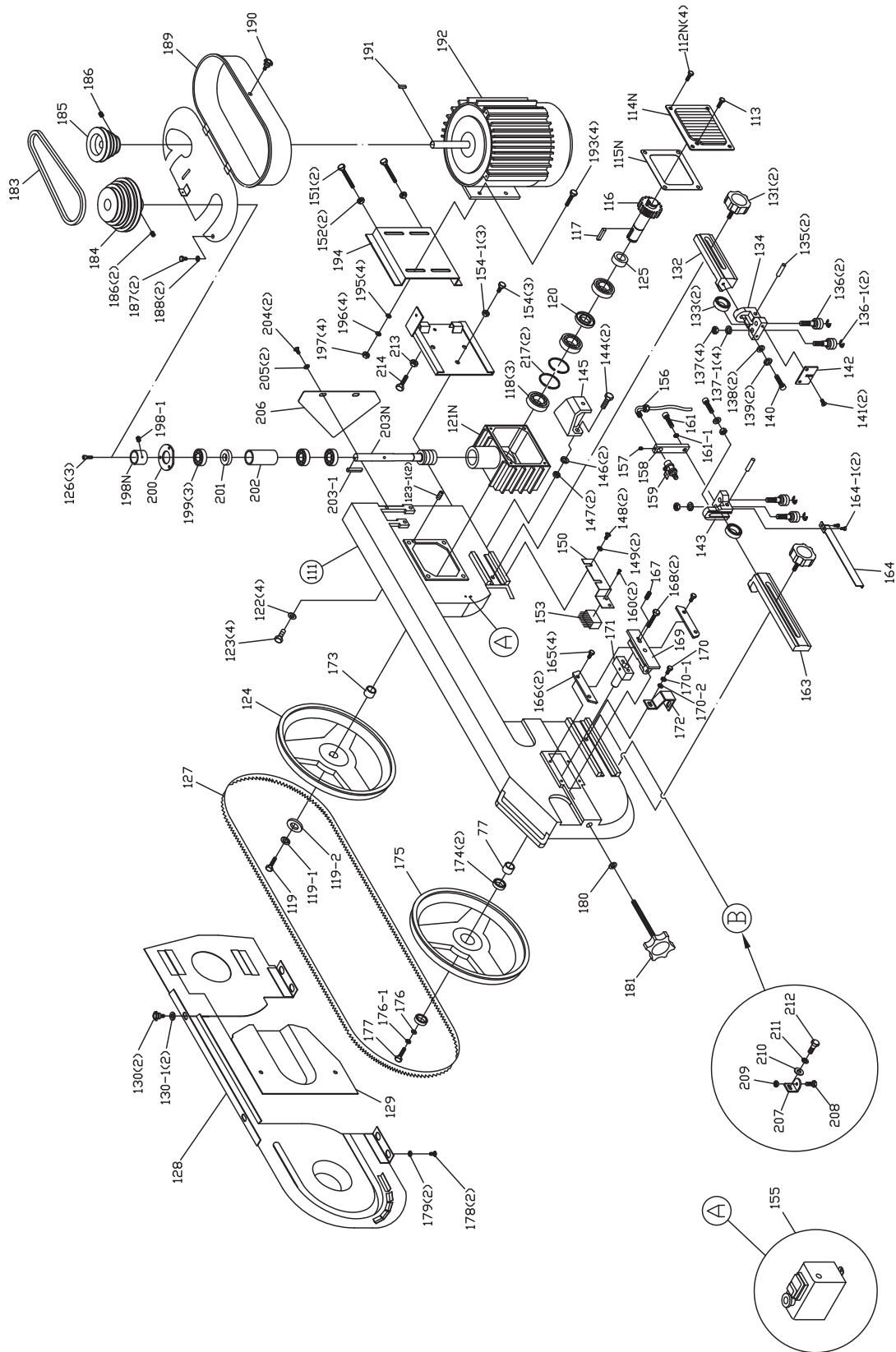

Figure 10 — Replacement Parts Illustration

REPAIR PARTS LIST FOR BAND SAW

Ref. No.	Description	Part No.	Qty.	Ref. No.	Description	Part No.	Qty.	Ref. No.	Description	Part No.	Qty.
1	Bottom Pan	9615742.00	1	46	Electric Box Assembly	9603936.00	1	84	Plate	9615763.00	1
2	Leg (Left)	9615826.00	1	47	Handle Wheel	9640991.01	1	85	Spring Washer, 3/8	*	2
3	Leg (Right)	9615744.00	1	48	Set Screw, 5/16x3/8	*	1	86	Hex. Hd. Screw, 3/8 x 1 1/2	*	2
4	Skirt	9615747.00	1	49	Key, M5x20	*	1	87	Spring	9615762.00	1
5	Shelf	9615745.00	1	50	Lead Screw	9615755.00	1	88	Adjustable Spring Rod	9603922.00	1
10	Switch Bracket	9615741.00	1	51	Nut Seat	9615754.00	1	89	Spring Bracket	9603923.00	1
11	Toggle Switch	9602432.00	1	52	Acme Nut	9615580.00	1	90	Hex. Hd. Screw, 5/16 x 1	*	1
12	Electrical Box	9615827.00	1	53	Button	9615582.00	1	91	Nut, 3/8	*	2
13	Hex. Hd. Screw, 5/16x3/4	*	8	54	Retainer	9603911.00	1	92	Spring Washer, 5/16	*	1
14	Washer, 5/16	*	8	55	Spring Washer, M5	*	1	92-1	Washer, 5/16	*	1
15	Washer, 5/16	*	8	56	Round Hd. Screw, M5x8	*	1	93	Nut, 5/16	*	1
16	Spring Washer, 5/16	*	8	57	Hex. Hd. Screw, 5/16x5/8	*	2	94	Front Vise	9615761.00	1
17	Nut, 5/16	*	8	58	Spring Washer, 5/16	*	2	95	Rear Vise	9615766.00	1
18	Hex. Hd. Screw, 5/16x1/2	*	6	58-1	Washer, 5/16	*	2	96	Vise Thrust Shaft	9640990.01	1
19	Nut, 5/16	*	6	59	Support Plate	9615756.00	1	96-1	Spring Washer, 3/8	*	2
20	Cylinder	9603945.00	1	60	Horizontal Stop Screw	9615757.00	1	96-2	Washer, 3/8	*	1
21	Hex. Soc. Screw, M10x40	*	1	61	Nut, 5/16	*	2	97	Hex. Hd. Screw, 3/8 x 1 1/2	*	1
22	Washer, 3/8	*	1	62	Hex. Hd. Screw, 3/8x1	*	1	98	Hex. Hd. Screw, 1/2 x 1 1/2	*	1
23	Spring Washer, M10	*	1	63	Nut, 3/8	*	1	98-1	Spring Washer, 1/2	*	2
24	Nut, M10	*	1	64	90° Position Support	9615765.00	1	98-2	Washer, 1/2	*	1
25	Hex. Hd. Scre, 3/8x1	*	2	65	Nut, 3/8	*	2	99	Hex. Hd. Screw, 1/2 x 1 1/4	*	1
26	Spring Washer, 3/8	*	2	66	Spring Washer, 3/8	*	2	100	Scale	9615767.00	1
27	Support Rod	9603940.01	1	67	Limit Switch	9640996.01	1	101	Hex. Soc. Screw 3/8 x 1 3/4	*	1
28	Set Screw, 1/4x3/8	*	1	68	Limit Switch Seat	9640987.01	1	101-1	Nut, 3/8	*	1
29	Bottom Support	9615746.00	1	69	Round Hd. Screw, 5/32x1	*	2	102	Hose	9615820.00	1
33	Washer, 5/8	*	4	70	Hex. Hd. Screw, 3/8x1 1/2	*	2	103	Pump	9615621.00	1
34	Wheel	9615824.00	4	71	Hex. Hd. Screw, 5/16x3/4	*	1	104	Hex. Hd. Screw, 1/4 x 1/2	*	4
35	Wheel Shaft	9615825.00	2	72	Thumb Screw	9603927.00	1	105	Strain Relief	*	1
36	Cotter Pin	9615033.00	4	73	Stop Block	9615751.00	1	107	Coolant Tank	9615818.00	1
37	Toggle Switch	9615753.00	1	74	Work Stop Rod	9615752.00	1	108	Hose Fitting	9615620.00	1
38	Electric Cord Assembly	9615817.00	1	75n	Fiber Hex. Nut, 1/2	*	2	109	Hose Clamp	9640992.01	1
39	Table	†	1	76	Washer, 1/2	*	2	110	Hose	9615821.00	1
40	Hex. Hd. Screw, 5/16x1	*	5	77	Bearing Bushing (Front)	9640988.01	1	111	Saw Bow	†	1
41	Washer, 5/16	*	5	78	Rubber Cover	9640989.01	1	112N	Tapping Screw, M6 x 20	*	4
42	Spring Washer, 5/16	*	5	79	Washer, 5/32	*	2	113	Vent Plug	9640993.01	1
43	Nut, 5/16	*	5	80n	Support Shaft	9615749.00	1	114N	Gear Box Cover	9640994.01	1
44	Filter	9615743.00	1	80-1	Bushing	9615750.00	1	115N	Gear Box Gasket	9640995.01	1
45	Round Hd. Screw, 3/16x 3/8	*	2	81	Pivot Arm	9615764.00	1	116	Worm Gear	9640996.01	1

(*) Standard hardware item, available locally.

(†) Not available as repair part.

REPAIR PARTS LIST FOR BAND SAW

Ref. No.	Description	Part No.	Qty.	Ref. No.	Description	Part No.	Qty.	Ref. No.	Description	Part No.	Qty.
117	Key, M6 x 20	9640997.01	1	148	Round Hd. Screw, 1/4 x 1/2	*	2	180	Washer, 3/8	*	1
118	Ball Bearing 6005zz	*	3	149	Washer, 1/4	*	2	181	Blade Adjustable Handle	9603972.00	1
119	Hex. Hd. Screw, 3/8 x 1	*	1	150	Brush Holder	9615801.00	1	183	Belt (3v270)	9641006.01	1
119-1	Spring Washer, 3/8	*	1	151	Hex. Hd. Screw, 5/16 x 2 1/2	*	2	184	Worm Pulley	9641007.01	1
119-2	Washer	9641019.01	1	152	Nut, 5/16	*	2	185	Motor Pulley	9641008.01	1
120	Oil Seal	9640998.01	1	153	Brush	9603975.00	1	186	Set Screw, 5/16 x 3/8	*	3
121n	Gear Box	9640999.01	1	154	Hex. Hd. Screw, 5/16 x 5/8	*	3	187	Hex. Hd. Screw, 1/4 x 1/2	*	2
122	Spring Washer, 5/16	*	4	154-1	Spring Washer, 5/16	*	3	188	Washer, 1/4	*	2
123	Hex. Hd. Screw, 5/16 x 1 1/4	*	4	155	Magnetic Switch	9641005.01	1	189	Pulley Cover	9641009.01	1
123-1	Adj. Screw, 1/4 x 3/8	*	2	156	Nozzle	9615794.00	1	190	Plum Screw	9641010.01	1
124	Blade Wheel (Rear)	9615809.00	1	157	Set Screw, 1/4 x 3/8	*	1	191	Key, M5 x 20	*	1
125	Bearing Bushing	9641000.01	1	158	Nozzle Support	9600632.00	1	192	Motor	9641011.01	1
126	Hex. Soc. Screw, 3/16 x 5/8	*	3	159	Valve	9603168.00	1	193	Hex. Hd. Screw, 5/16 x 1	*	4
127	Blade	9615103.00	1	160	Round Hd. Screw, 3/16 x 3/8	*	2	194	Motor Mount Plate	9641012.01	1
128	Blade Back Cover	9615808.00	1	161	Hex. Soc. Screw, 5/16 x 1 1/8	*	1	195	Washer, 5/16	*	4
129	Wheel Cover	9615807.00	1	161-1	Spring Washer, 5/16	*	1	196	Spring Washer, 5/16	*	4
130	Plum Screw	9601057.00	2	163	Adjustable Bracket (Front)	9615799.00	1	197	Nut, 5/16	*	4
130-1	Washer, 1/4	*	2	164	Blade Guard	9615798.00	1	198N	Worm Shaft Stopper	9641013.01	1
131	Adjustable Guide Knob	9603989.00	2	164-1	Round Hd. Screw, 3/16 x 1/4	*	2	198-1	Set Screw, 5/16 x 1/4	*	1
132	Adjustable Bracket (Rear)	9615788.00	1	165	Hex. Hd. Screw, 1/4 x 1/2	*	4	199	Ball Bearing 6003zz	*	3
133	Ball Bearing 608zz	*	2	166	Sliding Guide Plate	9615800.00	2	200	Block Plate	9641014.01	1
134	Adjustable Blade Seat (Rear)	9615789.00	1	167	Set Screw, 5/16 x 3/4	*	1	201	Oil Seal	9641015.01	1
135	Bearing Pin	9615790.00	2	168	Hex. Hd. Screw, 5/16 x 1 1/2	*	2	202	Bearing Bushing	9641016.01	1
136	Eccentric Shaft Assembly	9641003.01	2	169	Blade Tension Sliding Block	9615803.00	1	203N	Worm Shaft	9641017.01	1
136-1	Center Shaft Assembly	9641004.01	2	170	Hex. Hd. Screw, 1/4 x 1/2	*	1	203-1	Key, M5 x 50	*	1
137	Nut, 3/8 x 24unf	*	4	170-1	Spring Washer, 1/4	*	1	204	Hex. Hd. Screw, 1/4 x 1/2	*	2
137-1	Spring Washer, 3/8	*	4	170-2	Washer, 1/4	*	1	205	Washer, 1/4	*	2
138	Washer, 5/16	*	2	171	Sliding Draw Block	9615802	1	206	Support Plate	9615811.00	1
139	Spring Washer, 5/16	*	2	172	Bracket	9641001.01	1	207	Limit Switch Rack	9641018.01	1
140	Hex. Soc. Screw, 5/16 x 1 1/8	*	1	173	Bearing Bushing (Rear)	9641002.01	1	208	Hex. Hd. Screw, 1/4 x 1/2	*	1
141	Hd. Screw, 1/4 x 1/2	*	2	174	Ball Bearing 6203zz	*	2	209	Nut, 1/4	*	1
142	Vertical Cutting Plate (Small)	9615793.00	1	175	Blade Wheel (Front)	9615806.00	1	210	Washer, 1/4	*	1
143	Adjustable Blade Seat (Front)	9615797.00	1	176	Washer, 5/16	*	1	211	Spring Washer, 1/4	*	1
144	Hex. Hd. Screw, 3/8 x 1 1/4	*	2	176-1	Spring Washer, 5/16	*	1	212	Hex. Hd. Screw, 1/4 x 1/2	*	1
145	Top Support	9615795.00	1	177	Hex. Hd. Screw, 5/16 x 3/4	*	1	213	Nut, 5/16	*	1
146	Spring Washer, 3/8	*	2	178	Round Hd. Screw, 1/4 x 1/2	*	2	214	Hex. Hd. Screw, 5/16 x 1 1/4	*	1
147	Nut, 3/8	*	2	179	Washer, 1/4	*	2	217	C-Ring (R47)	*	2

(*) Standard hardware item, available locally.

(†) Not available as repair part.

PALMGREN WARRANTY

C.H. Hanson / Palmgren warrants their products to be free of defects in material or workmanship. This warranty does not cover defects due directly or indirectly to misuse, abuse, normal wear and tear, failure to properly maintain the product, heated, ground or otherwise altered, or used for a purpose other than that for which it was intended.

The warranty does not cover expendable and/or wear part (i.e. v-belts, screws, abrasives, jaws), damage to tools arising from alteration, abuse or use other than their intended purpose, packing and freight. The duration of this warranty is expressly limited to the terms noted below beginning from the date of delivery to the original user.

The Palmgren branded items carry the following warranties on parts:

All vises, clamps, positioning tables, tombstones, jack screws and vise accessories - LIFETIME.

All bench grinders, drill presses, tapping machines, band saws, lathes, milling machines, arbor presses, abrasive finishing machines and work stands - 3 YEARS.

The obligation of C.H. Hanson / Palmgren is limited solely to the repair or replacement, at our option, at its factory or authorized repair agent of any part that should prove inoperable. Purchaser must lubricate and maintain the product under normal operating conditions at all times. Prior to operation become familiar with product and the included materials, i.e. warnings, cautions and manuals.

Failure to follow these instructions will void the warranty.

This warranty is the purchaser's exclusive remedy against C.H. Hanson for any inoperable parts in its product. Under no circumstances is C.H. Hanson liable for any direct, indirect, incidental, special or consequential damages including loss of profits in any way related to the use or inability to use our products. This warranty gives you specific legal rights which may vary from state to state.

PALMGREN®

Palmgren - a C.H. Hanson Company
2000 N. Aurora Rd., Naperville, IL 60563 U.S.A.
or call 1-800-827-3398