



Manufactured by:
 Backyard Discovery
 3305 Airport Drive, Pittsburg, KS 66762
 800-856-4445

Basepoint Business Centre: Rivermead Drive, Westlea, Swindon SN5 7EX Phone: 0800-118-2476
 J.P. Coenstraat 7, The Bridge, The Hague, 2595 WP, Netherlands Phone: 08005678990

20x9.5 STONEBRIDGE GAZEBO

MODEL # : 2307117B



Please visit www.backyarddiscovery.com
 For the most up to date assembly manual, to register your product, or to order replacement parts *Para obtener instrucciones en español, visite* www.backyarddiscovery.com



EASY STEP-BY-STEP
 3D INTERACTIVE INSTRUCTIONS
 DOWNLOAD THE FREE APP



OWNER'S MANUAL - BASIC SETUP DIMENSIONS & ASSEMBLY NOTES

It is critically important that you start with square and level footings, concrete pad or deck to attach your structure

- Pay close attention to the items needed for each step. Make sure you are using the correct hardware for each step. Using incorrect hardware may result in improper assembly
- Remember to double check for underground utilities and overhead electrical lines

Post mounts are provided with your structure which allows you to permanently install your structure to a pre-existing or new wood or concrete surface. See Anchor Instructions for further details and recommendations.

- The hardware to attach the post mounts to the structure is included.
- The hardware to mount the structure permanently to a concrete surface is included.
- The hardware to mount the structure permanently to a wood deck is NOT included and will need to be purchased separately. You must ensure there is ample structural support under the deck before permanently attaching.

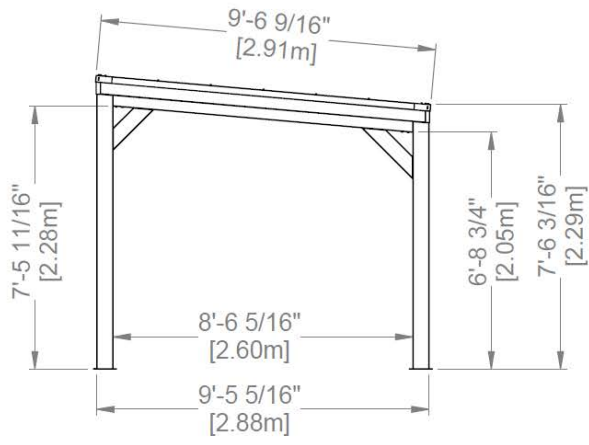
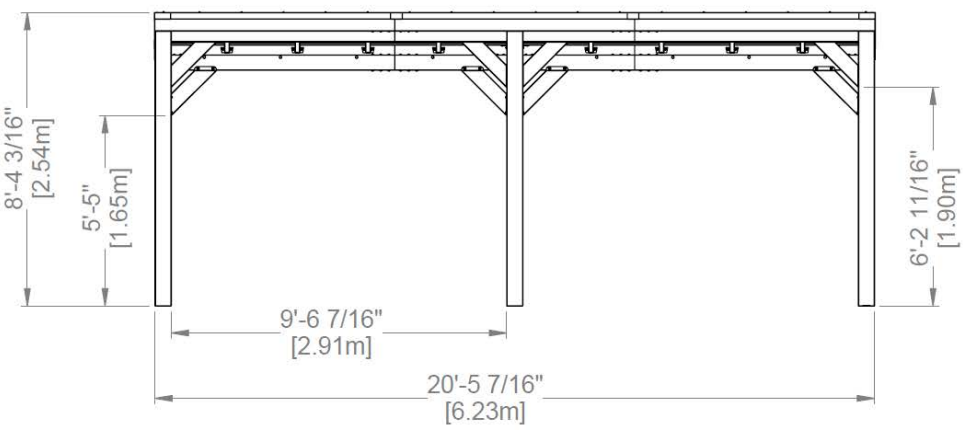
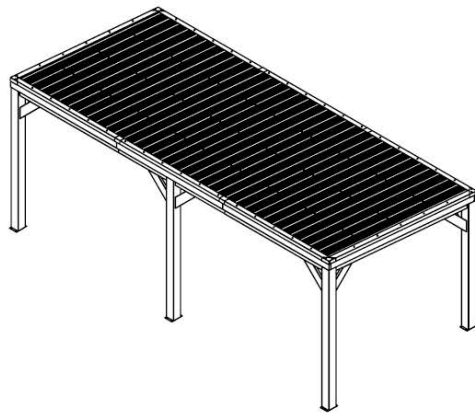
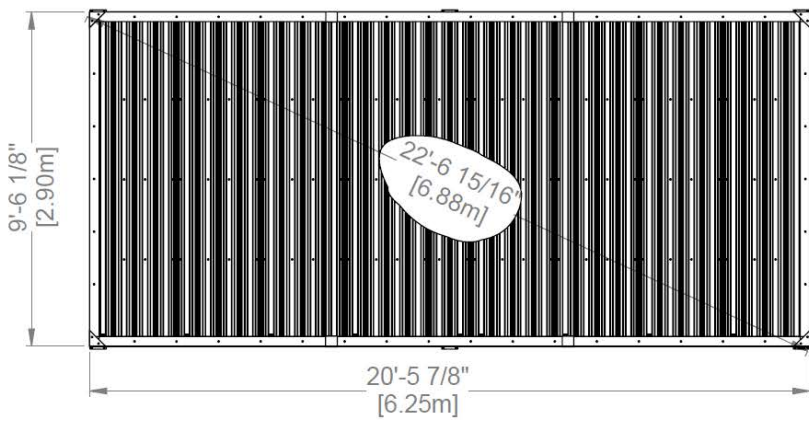

OWNER'S MANUAL - ANCHORING LAYOUT

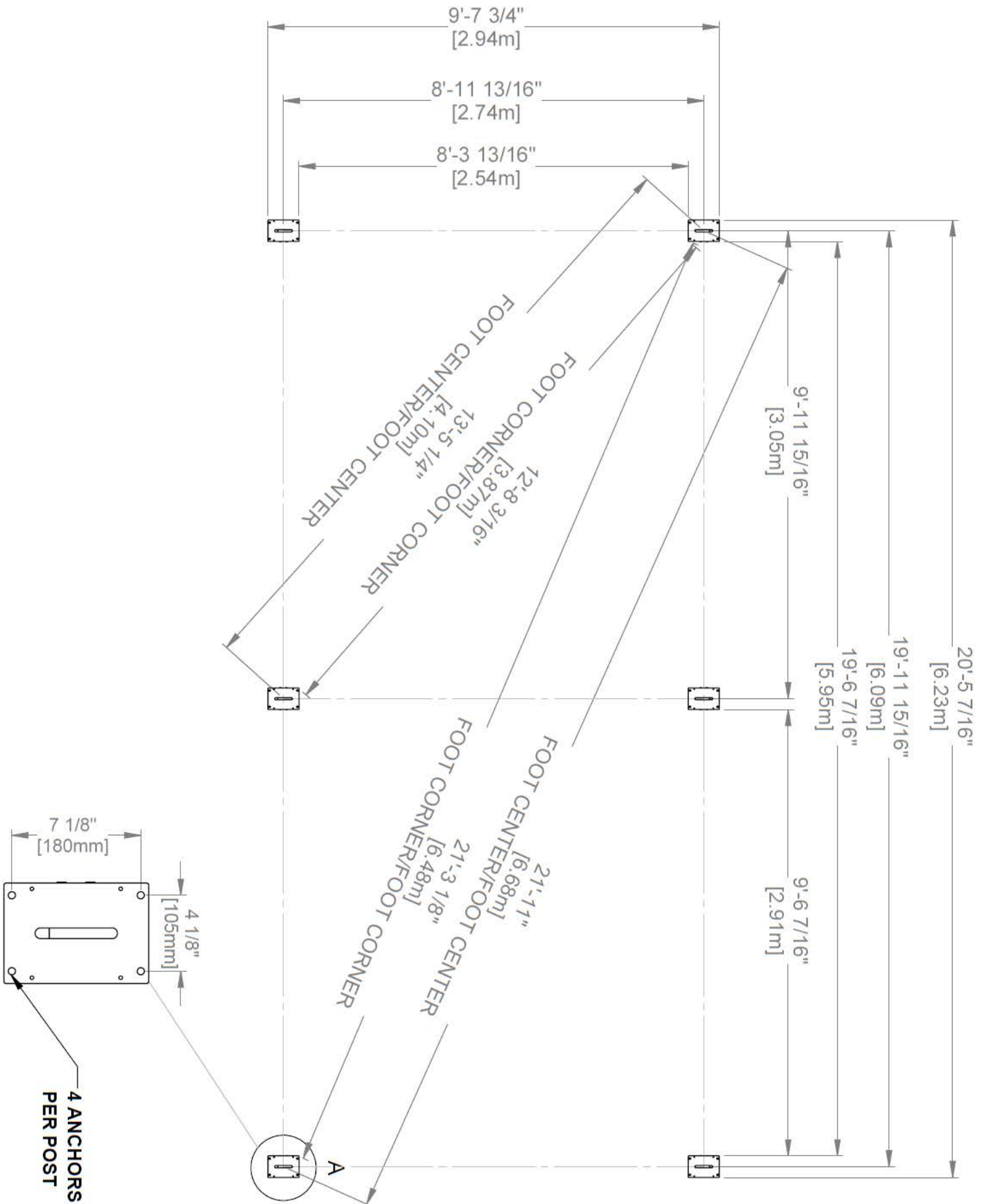

OWNER'S MANUAL - PARTS IDENTIFICATION

METAL COMPONENTS (NOT TO SCALE)

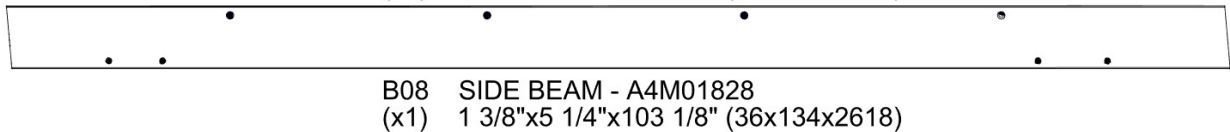
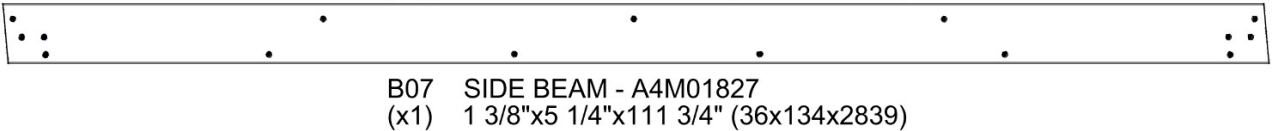
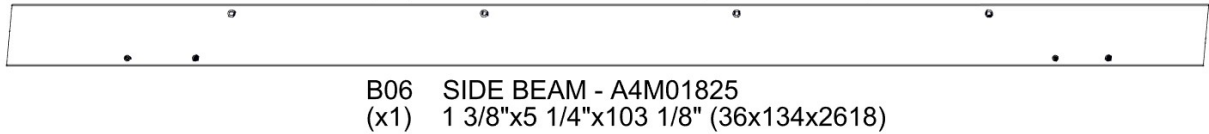
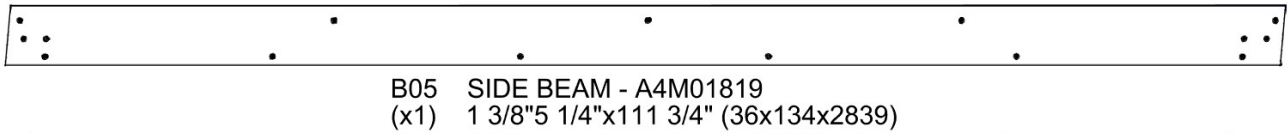
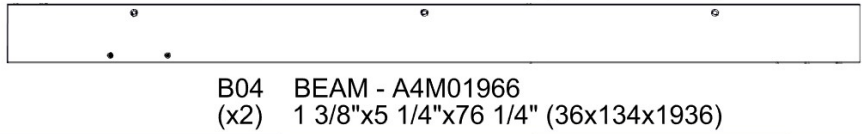
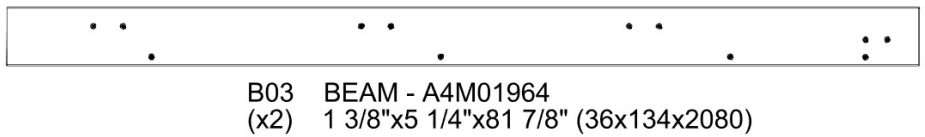
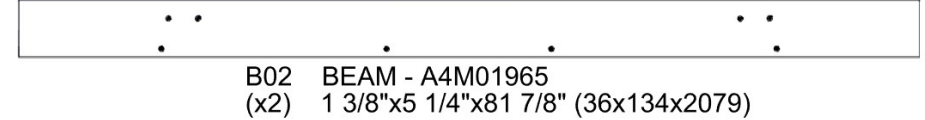
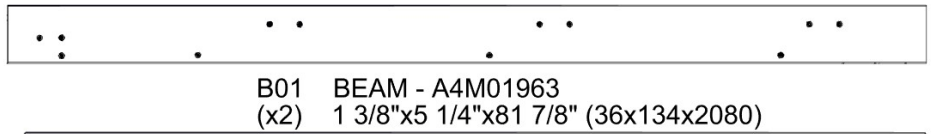
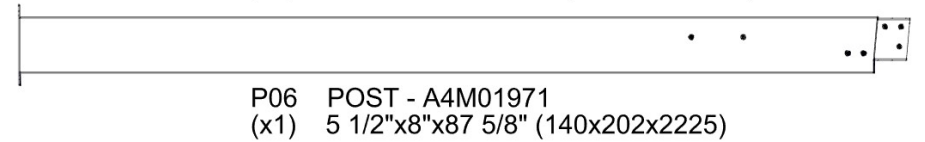
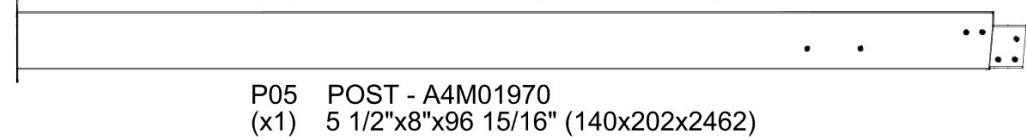
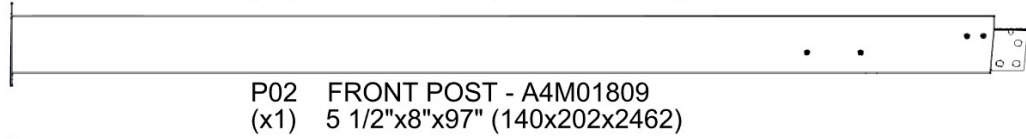
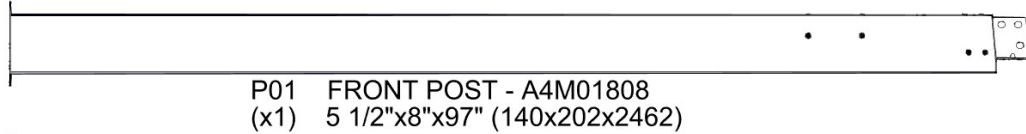

OWNER'S MANUAL - PARTS IDENTIFICATION

METAL COMPONENTS (NOT TO SCALE)



B09 BEAM - A4M01969
(x2) 1 3/8"x5 1/4"x38 1/8" (36x134x969)



B10 BEAM - A4M01968
(x2) 1 3/8"x5 1/4"x38 1/8" (36x134x969)



B11 BEAM - A4M01967
(x2) 1 3/8"x5 1/4"x76 1/4" (36x134x1936)



B12 MIDDLE BEAM - A4M01972
(x1) 1 3/8"x5 1/4"x111 3/4" (36x134x2837)

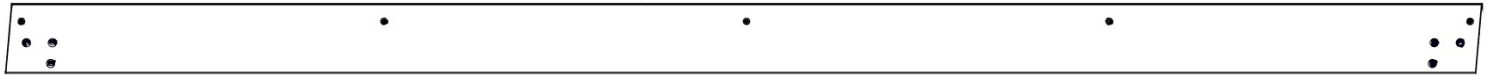

B13 MIDDLE BEAM - A4M01973
(x1) 1 3/8"x5 1/4"x111 3/4" (36x134x2837)



C01 RAFTER - A4M01833
(x8) 1 5/8"x2 3/8"x111 1/2" (40x60x2831)



D01 CORBEL - A4M01817
(x4) 2 3/4"x5 13/16"x22 1/4" (70x147x565)



D02 CORBEL - A4M01818
(x4) 2 3/4"x5 13/16"x22 1/4" (70x147x565)



D03 CORBEL - A4M01826
(x1) 2 3/4"x5 11/16"x20 1/16" (70x145x509)



D04 CORBEL - A4M01830
(x1) 2 3/4"x5 11/16"x20 1/16" (70x145x509)



D05 CORBEL - A4M01831
(x1) 2 3/4"x5 7/8"x24 13/16" (70x149x631)



D06 CORBEL - A4M01832
(x1) 2 3/4"x5 7/8"x24 13/16" (70x149x631)



E01 PURLIN - A4M01975
(x10) 3/4"x1 5/8"x71 1/4" (20x40x1810)



E02 PURLIN - A4M01976
(x10) 3/4"x1 5/8"x47 1/8" (20x40x1198)

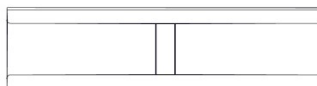

J1 SPLICE BRACKET - A4M01980
(x8) 1 5/16"x5 3/16"x19 11/16" (33.2x131x500)

OWNER'S MANUAL - PARTS IDENTIFICATION

METAL COMPONENTS (NOT TO SCALE)



A4M01814 BEAM BRACKET
(x8)



A4M01820 ANGLED BEAM BRACKET
(x2)

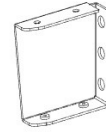

A4M01824 ANGLED BEAM BRACKET
(x2)

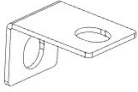

A4M01844 PURLIN BRACKET
(x20)

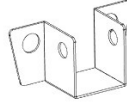

A4M01834 RAFTER BRACKET
(x16)



A4M01352 HOLE COVER
(x40)



A4M02929 EDGE
TRIM SPLICE
(x4)

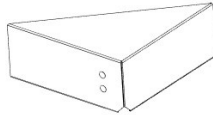

A4M02930 CORNER PROTECTOR
(x2)

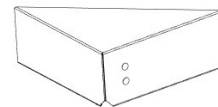

A4M02931 CORNER PROTECTOR
(x2)

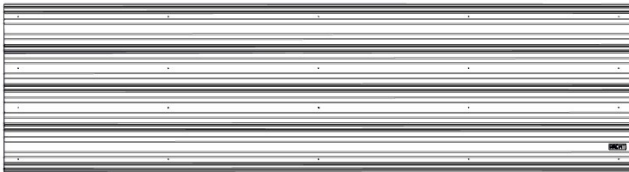

A4M02925 29GA STEEL SHEETING
(x8)



A4M02926 29 GA STEEL SHEETING
(x1)

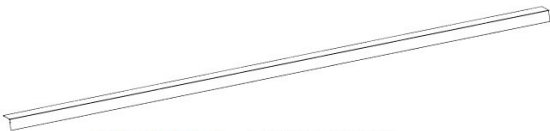

A4M02927 EDGE TRIM
(x2)

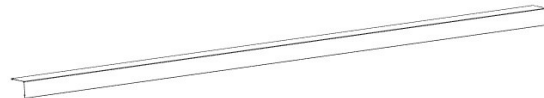

A4M02928 EDGE TRIM
(x6)



A6P00530 2-WAY SQUARE PLUG
(x10)

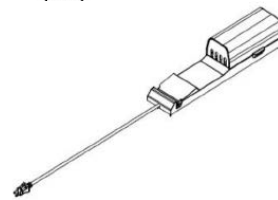

9205413 ELECTRICAL ENCLOSURE
(x1)

OWNER'S MANUAL - PARTS IDENTIFICATION

HARDWARE COMPONENTS (NOT TO SCALE)

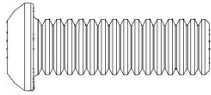

H101101 TORX PAN HEAD
(x312) 1/4-20x3/4

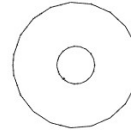

H101053 STEEL WASHER
(x312) 6x20

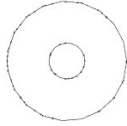

H101054 SEALANT WASHER
(x312)

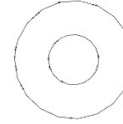

H100630 FLAT WASHER BLK
(x40) 8x19

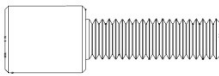

H101132 TORX SOCKET SCREW SHORT
(x40) 1/4-20

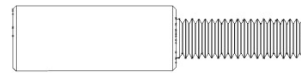

H101103 TORX SOCKET SCREW
(x40) 1/4-20



H100567 BOLT WH BLK
(x16) 1/4x2 1/4



H100653 NUT LOCK BLK
(x16) 1/4

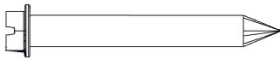

H100120 CONCRETE ANCHOR
(x24) 1/4x2

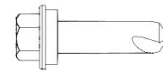

H101116 SCREW SELF TAPPING
(x50) 1/4x1 BLK



H101117 SCREW WOODGRIP
(x170) 10x3/4 BLK

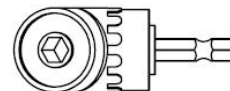

H101114 RIGHT ANGLE
(x1) DRILL ADAPTER

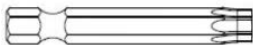

H100147 TORX BIT
(x1) T-30



H101100 MAGNETIC DRIVER
(x1)



H100114 TORX WRENCH
(x1) T-30

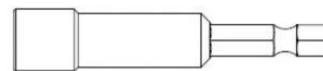

H101106 SOCKET DRIVER
(x1)

PRE-ASSEMBLY STEP 1 - SORTING PARTS

It is critical for ease of assembly that you take the time to sort and organize the parts and hardware.

METAL PARTS:

- Organize metal parts by the three-digit, alpha-numeric number stamped on each part (ex. P01).
- If there are multiple parts with the same stamped number, stack those pieces together.
- Stamps can be found on the flat surface of the parts or on the end of the parts.
- Allow yourself plenty of room - the parts can take up a significant amount of space.

NOTE: CARTONS ARE NOT ORGANIZED BY PART NUMBER.

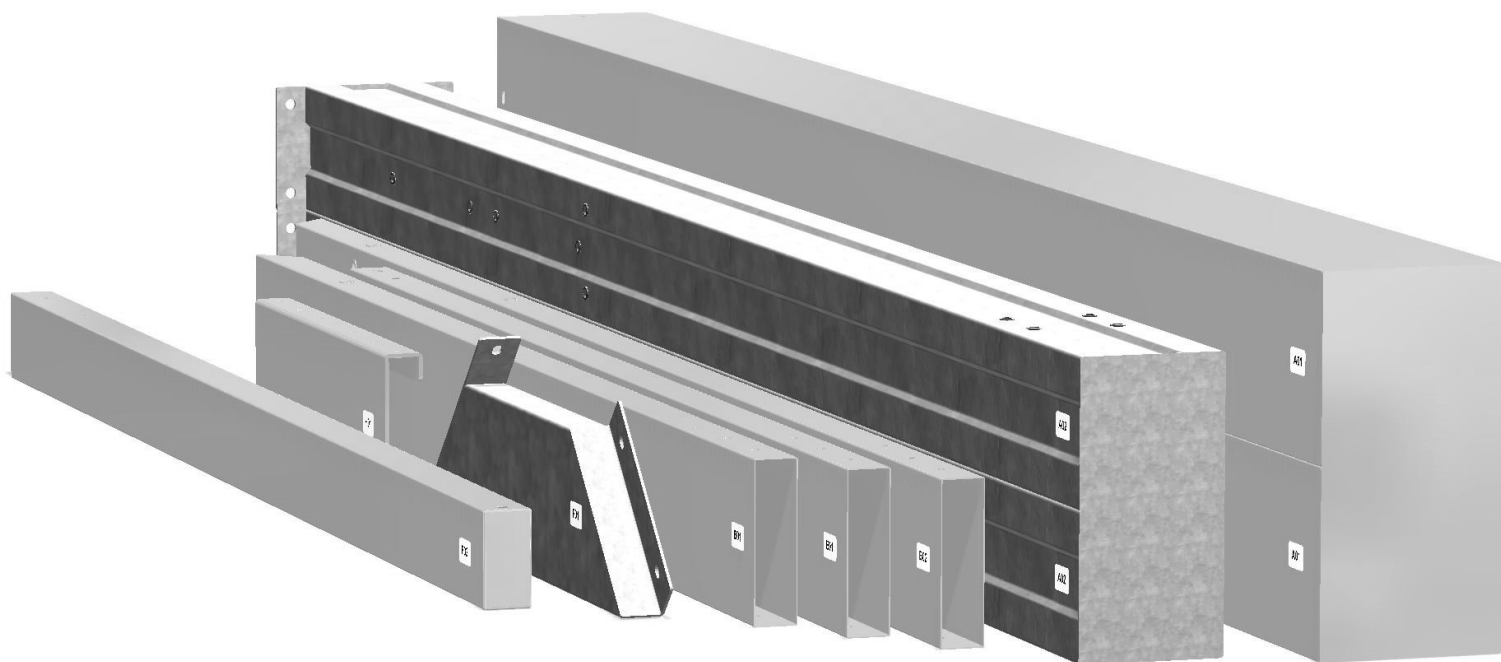

HARDWARE PARTS:

- We recommend that you have a separate table to organize the hardware.
- Hardware bags are printed with a seven-digit, alpha-numeric part number.
- You can organize your hardware by part number or group by hardware type (i.e. bolts, nuts, etc.).
- During assembly you only need to reference the last four digits of the number.

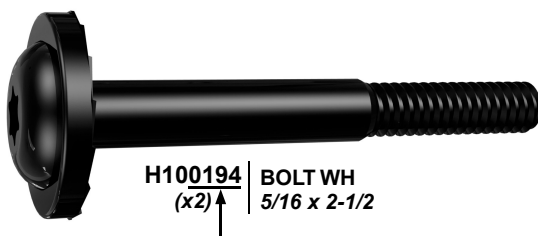

PRE-ASSEMBLY STEP 2 - TOOLS REQUIRED



Cordless Drill or Electric Drill



Drill Attachments:
Phillips Head



1/8", 3/16", 3/8" &
7/16" Drill Bits



Phillips Screw Driver

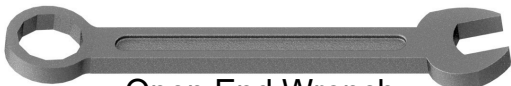

Open End Wrench
7/16"



3/8" Drive Ratchet, 1/2" &
7/16" STD Sockets 1/2" & 7/16"
Deep Sockets



Claw Hammer



Rubber Mallet -
Optional



Tape Measure

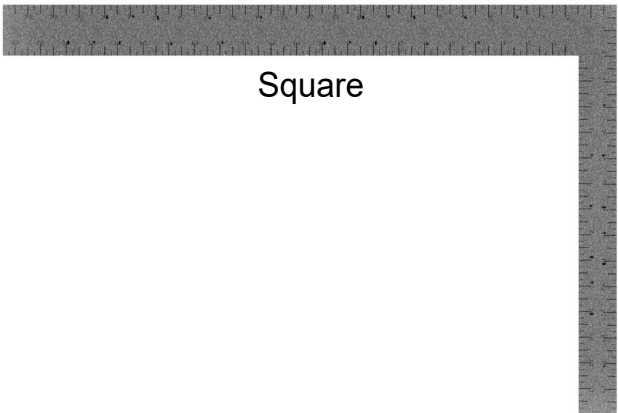

Square



Level 24"

PRE-ASSEMBLY STEP 3 - CHOOSE YOUR ASSEMBLY METHOD

There are several types of assembly instructions available to you.

1. Printed Assembly Manual included with your set
2. BILT APP - 3D interactive instructions
3. Combination of the Printed Manual and BILT APP (Note: Step numbers can differ between the two methods)



BILT.

Scan for easy
3D instructions

Download the BILT app
before you begin

Download on the
App Store

GET IT ON
Google Play

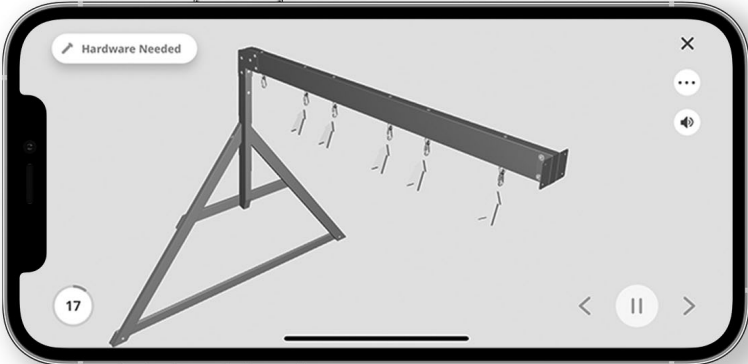

Hardware Needed

17

< || >

The image shows a smartphone screen displaying a 3D assembly instruction. The screen features a 3D model of a metal frame with a horizontal bar and several hanging components. A 'Hardware Needed' button is visible in the top left corner of the app interface. The step number '17' is shown in a circle in the bottom left corner. Navigation controls, including a back arrow, a pause button, and a forward arrow, are located at the bottom of the screen.

STEP 1 - BEAM ASSEMBLY

Qty	PART NUMBER	Description
4	H101103	TORX SOCKET SCREW 1/4-20



B08 SIDE BEAM - A4M01828
(x1) 1 3/8"x5 1/4"x103 1/8" (36x134x2618)



B07 SIDE BEAM - A4M01827
(x1) 1 3/8"x5 1/4"x111 3/4" (36x134x2839)

FOR EASE OF ASSEMBLY, WE RECOMMEND USING SAW HORSES FOR STEPS 1-29.

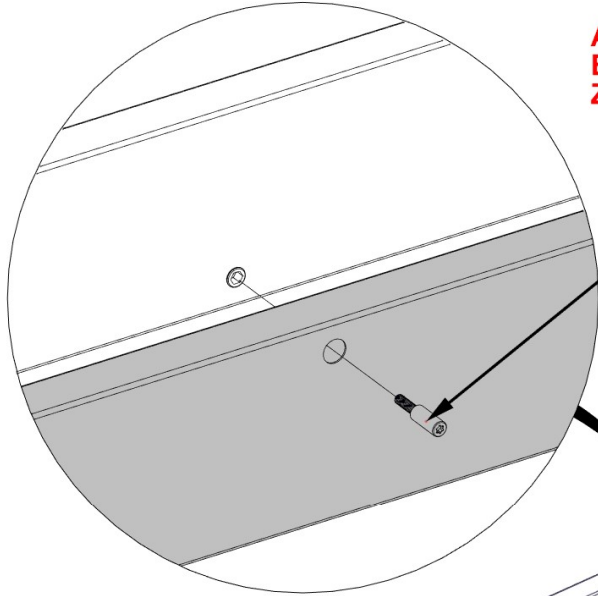

ALIGN THRU HOLES IN B08 SIDE BEAM WITH ZERTS IN B07 SIDE BEAM

**1103 (x4)
TORX SOCKET SCREW 1/4-20**

**B07 (x1)
SIDE BEAM**

**B08 (x1)
SIDE BEAM**

DIMENSIONS ARE THE SAME AT BOTH ENDS AND CRITICAL TO THE BEAM ASSEMBLY

FRONT VIEW

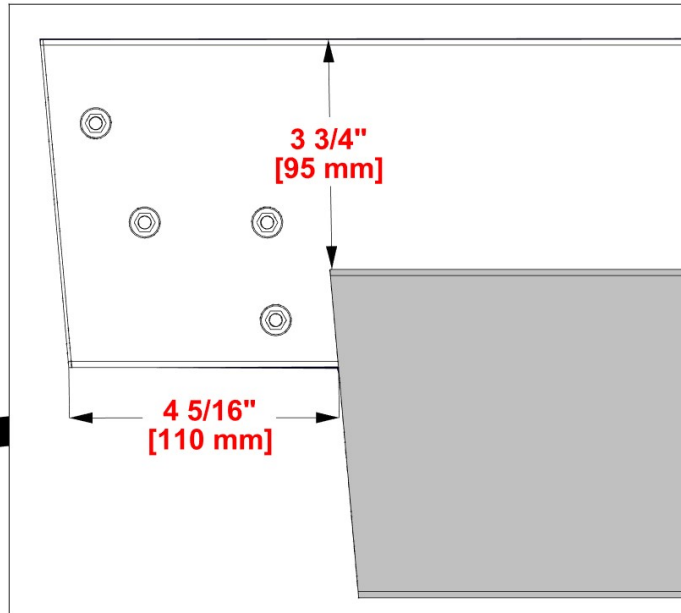

STEP 2 - BEAM ASSEMBLY

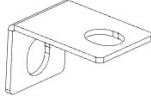

A4M01844 PURLIN BRACKET
(x5)

Qty	PART NUMBER	Description
5	H101101	TORX PAN HEAD 1/4-20x3/4"
5	H101053	STEEL WASHER 6x20
5	H101054	SEALANT WASHER

DO NOT FULLY TIGHTEN BOLTS AT THIS STEP

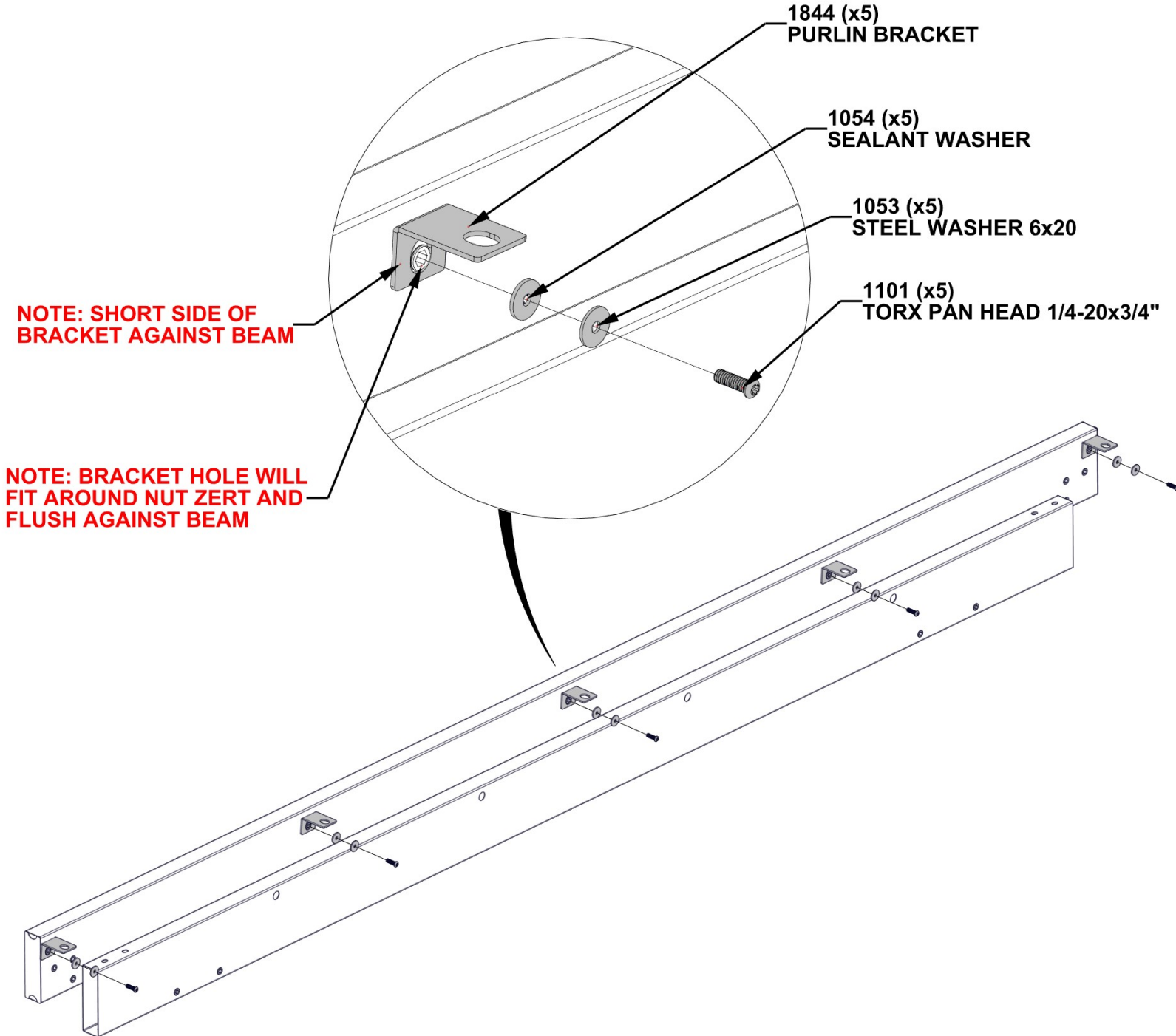

STEP 3 - POST ASSEMBLY

Qty	PART NUMBER	Description
2	H101101	TORX PAN HEAD 1/4-20x3/4"
2	H101053	STEEL WASHER 6x20
2	H101054	SEALANT WASHER



P02 FRONT POST - A4M01809
(x1) 5 1/2"x8"x97" (140x202x2462)



A4M01824 ANGLED BEAM BRACKET
(x1)

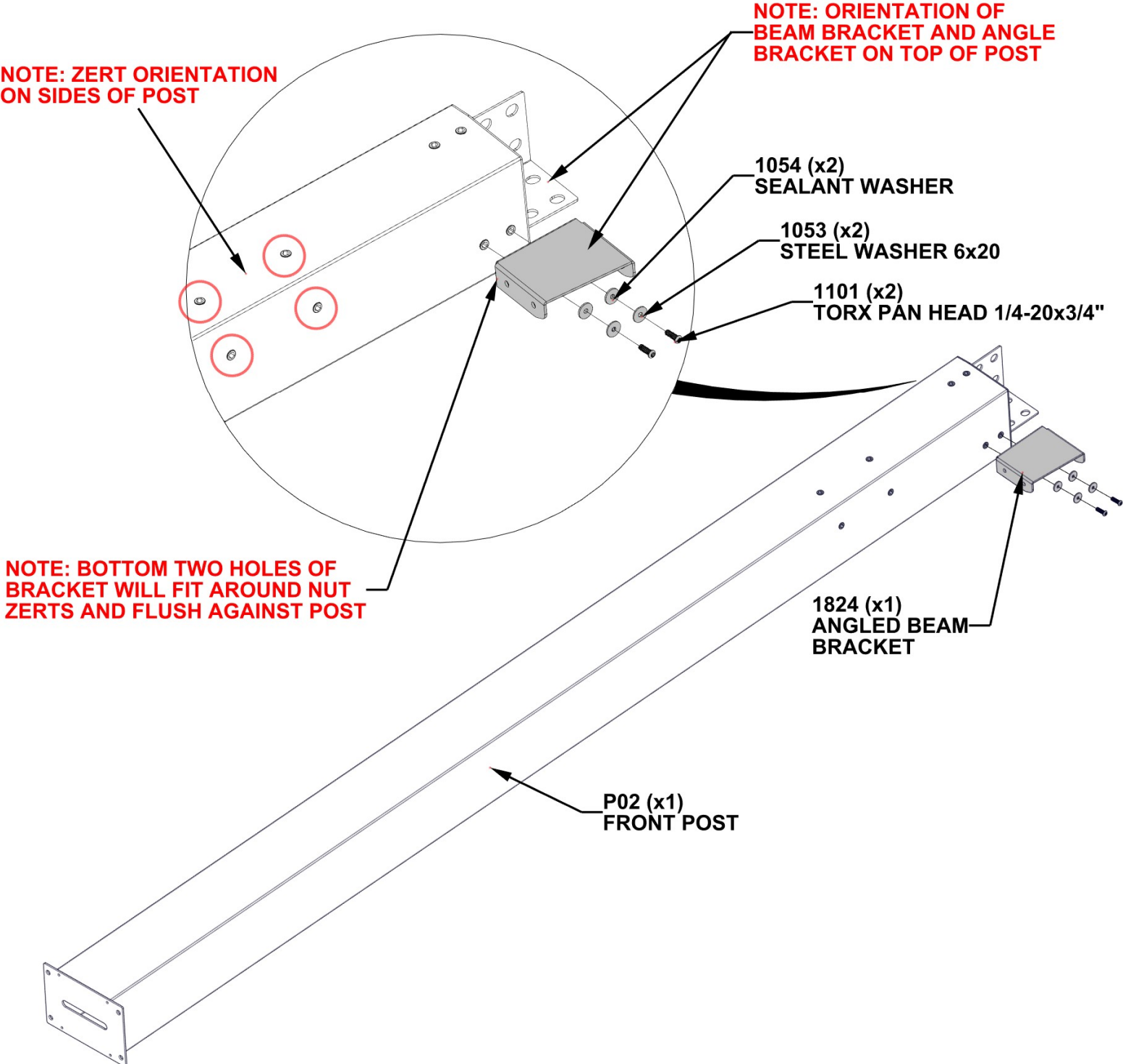

STEP 4 - POST ASSEMBLY

Qty	PART NUMBER	Description
2	H101054	SEALANT WASHER
2	H101053	STEEL WASHER 6x20
2	H101101	TORX PAN HEAD 1/4-20x3/4"

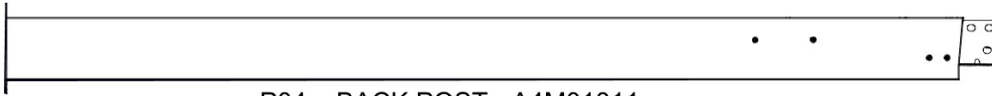

P04 BACK POST - A4M01811
(x1) 5 1/2"x8"x87 5/8" (140x202x2225)



A4M01824 ANGLED BEAM BRACKET
(x1)

NOTE: ORIENTATION OF BEAM BRACKET AND ANGLE BRACKET ON TOP OF POST

NOTE: ZERT ORIENTATION ON SIDES OF POST

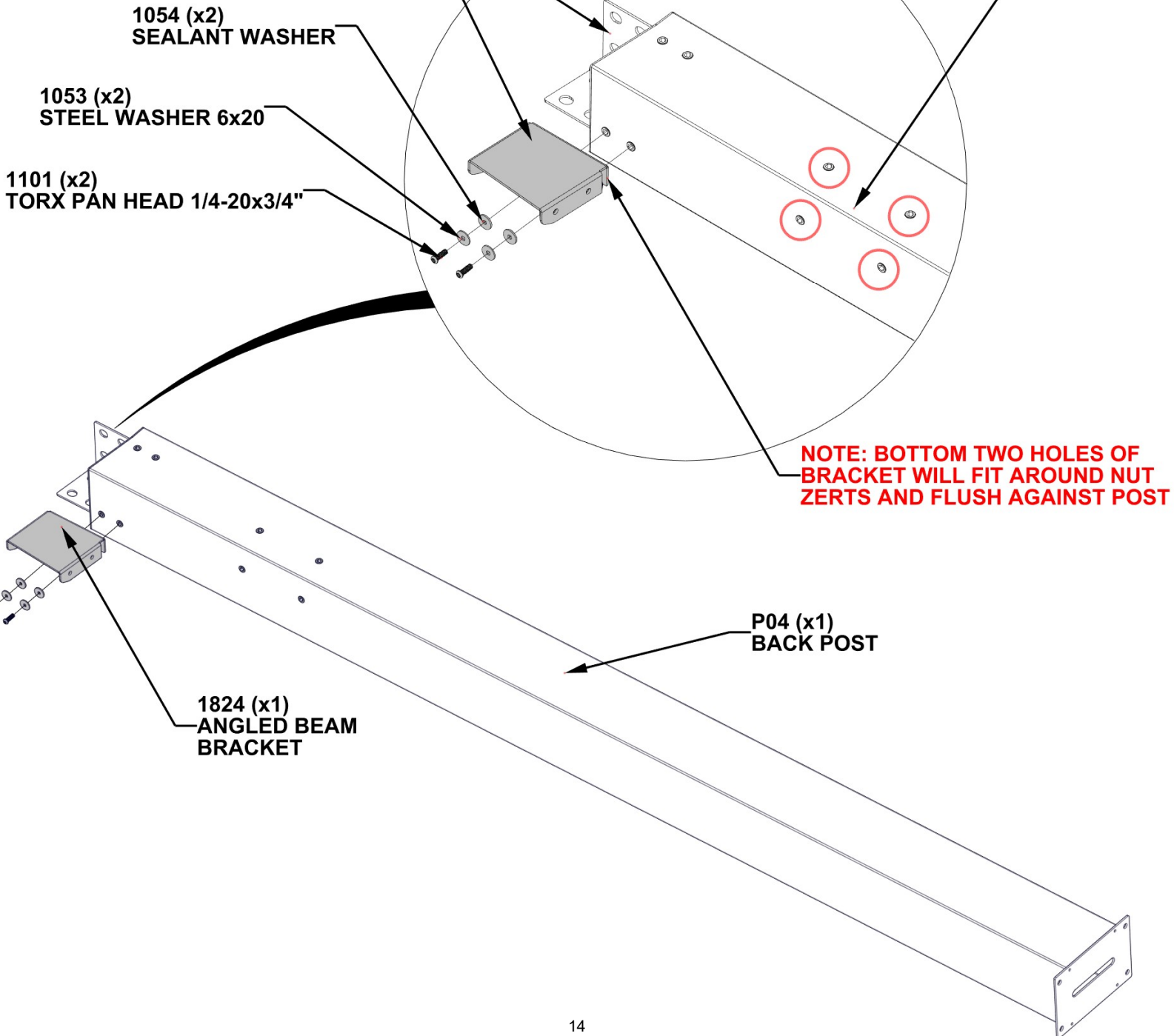

STEP 5A - LEFT SIDE POST ASSEMBLY

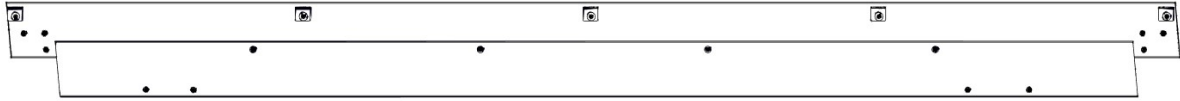

BEAM ASSEMBLY FROM STEPS 1-2

SLIDE EACH POST ASSEMBLY INTO THE BEAM ASSEMBLY FROM STEPS 1-2

NOTE: POST ORIENTATION. ZERTS WILL FACE UP AND TOWARD EACH OTHER ON POST.

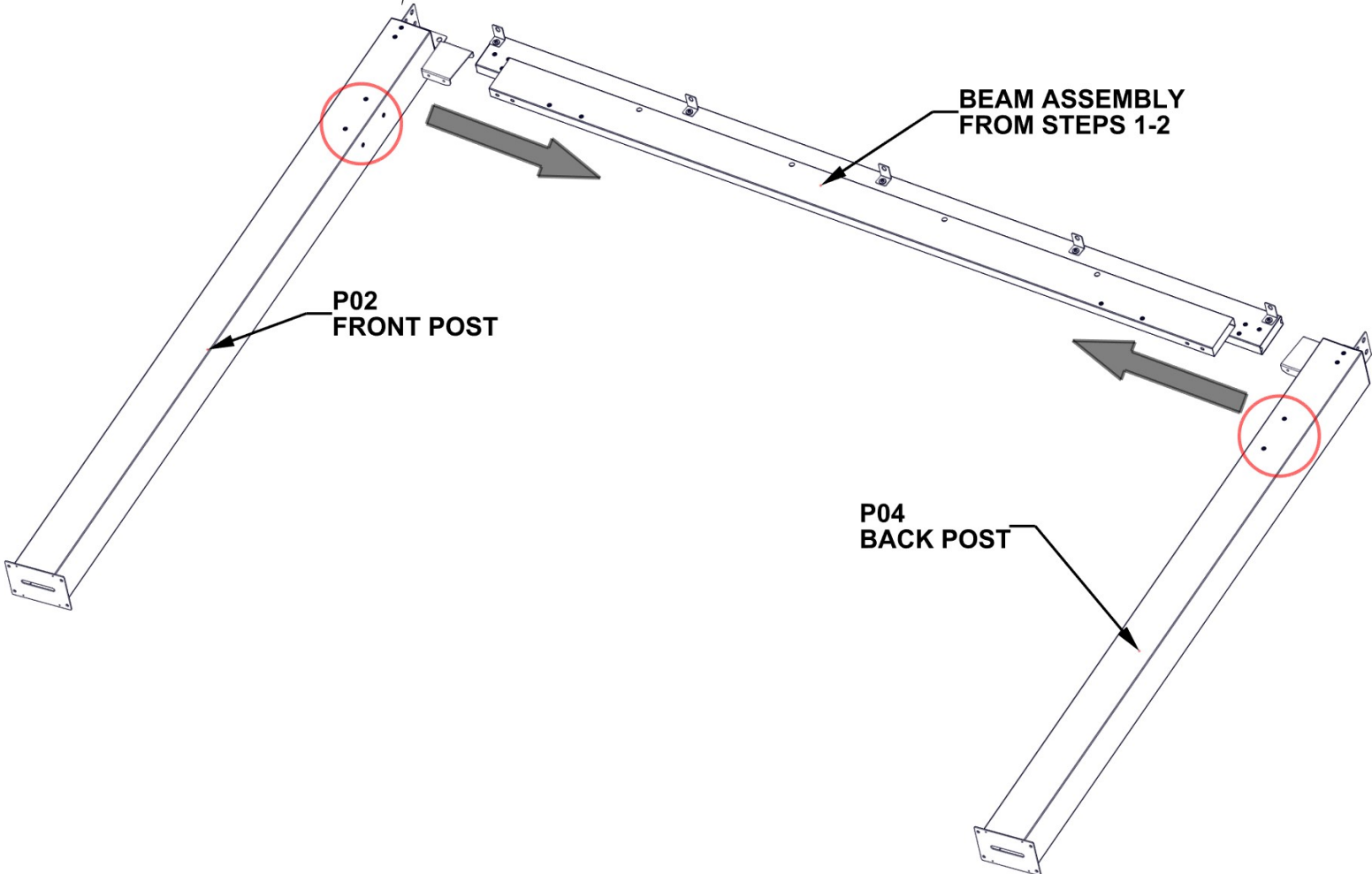
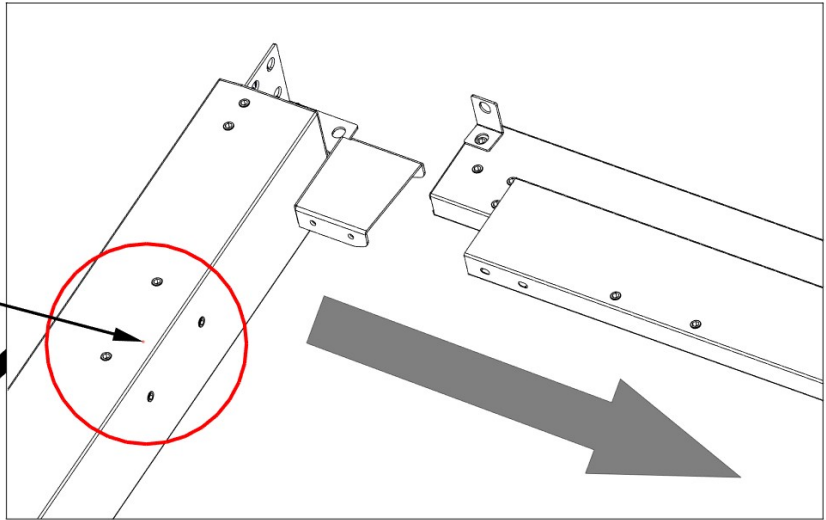

STEP 5B - LEFT SIDE POST ASSEMBLY

Qty	PART NUMBER	Description
6	H101054	SEALANT WASHER
6	H101101	TORX PAN HEAD 1/4-20x3/4"
6	H101053	STEEL WASHER 6x20

DO NOT FULLY TIGHTEN BOLTS AT THIS STEP

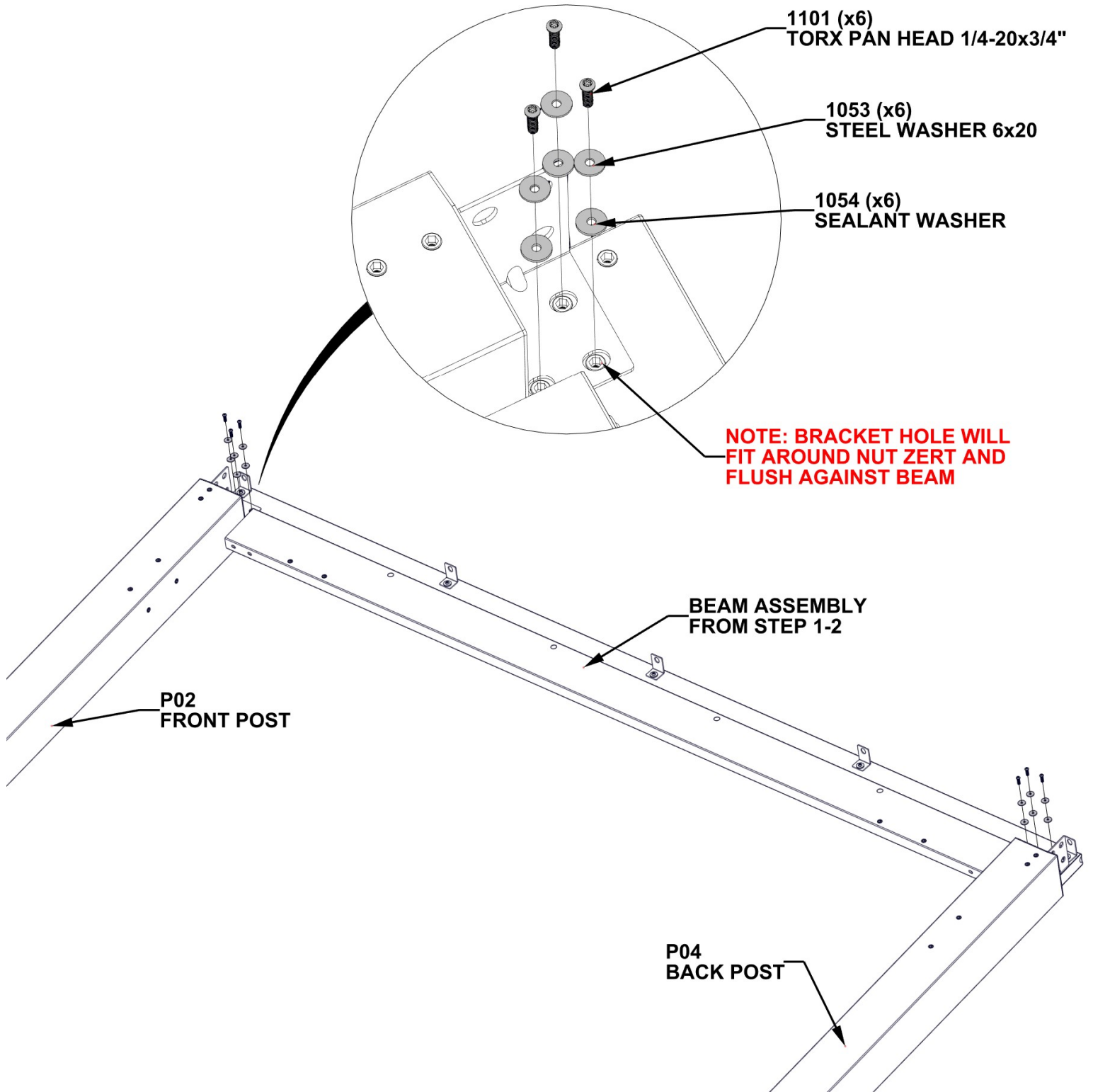

STEP 5C - LEFT SIDE POST ASSEMBLY

Qty	PART NUMBER	Description
8	H101054	SEALANT WASHER
8	H101101	TORX PAN HEAD 1/4-20x3/4"
8	H101053	STEEL WASHER 6x20

DO NOT FULLY TIGHTEN BOLTS AT THIS STEP

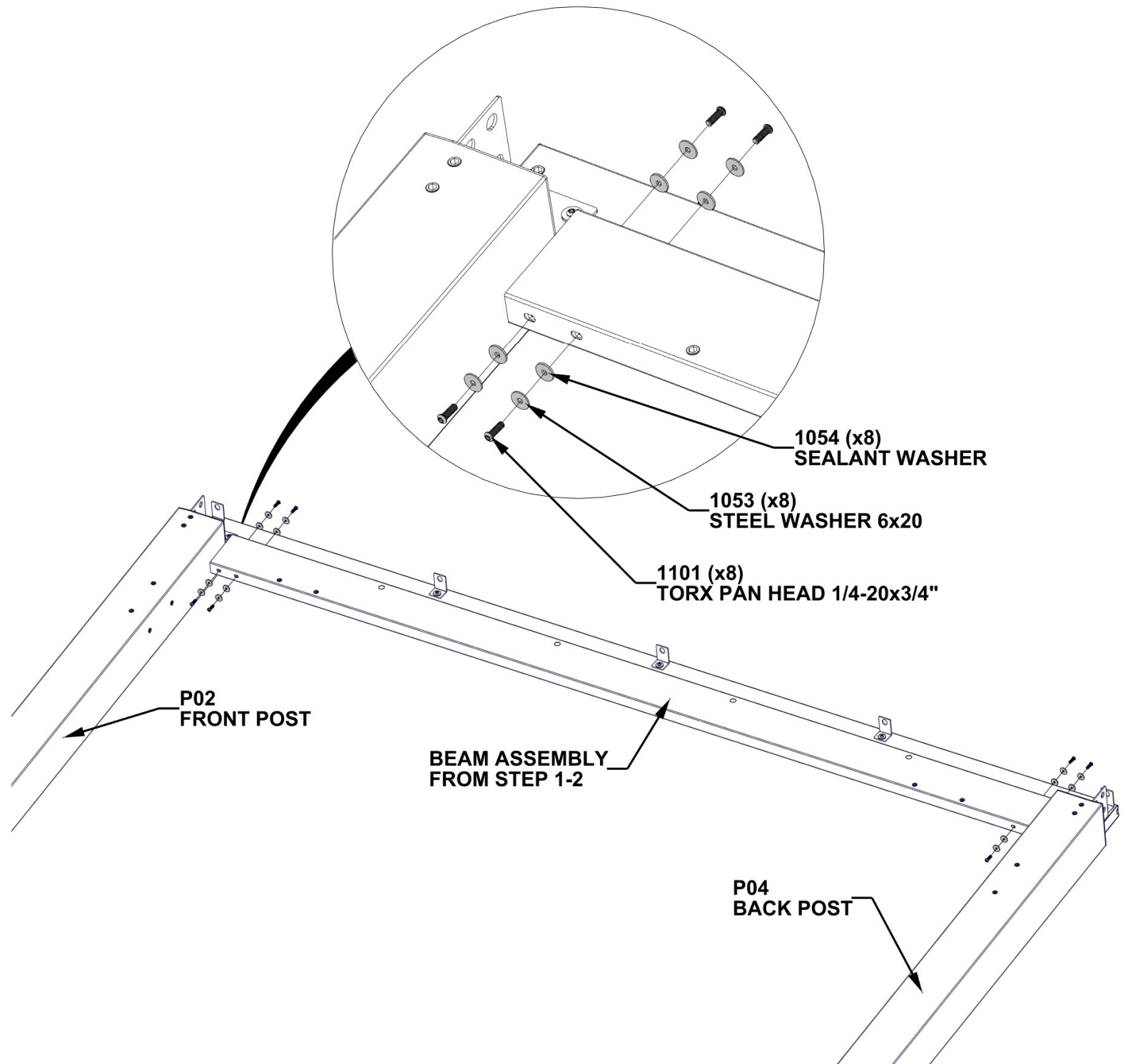

STEP 6 - LEFT SIDE POST ASSEMBLY

Qty	PART NUMBER	Description
8	H101054	SEALANT WASHER
8	H101101	TORX PAN HEAD 1/4-20x3/4"
8	H101053	STEEL WASHER 6x20



D04 CORBEL - A4M01830
(x1) 2 3/4"x5 11/16"x20 1/16" (70x145x509)



D06 CORBEL - A4M01832
(x1) 2 3/4"x5 7/8"x24 13/16" (70x149x631)

**ATTACH CORBELS TO BEAM AND POST.
SQUARE AS NEEDED BEFORE TIGHTENING
ALL HARDWARE FROM PREVIOUS STEPS.**

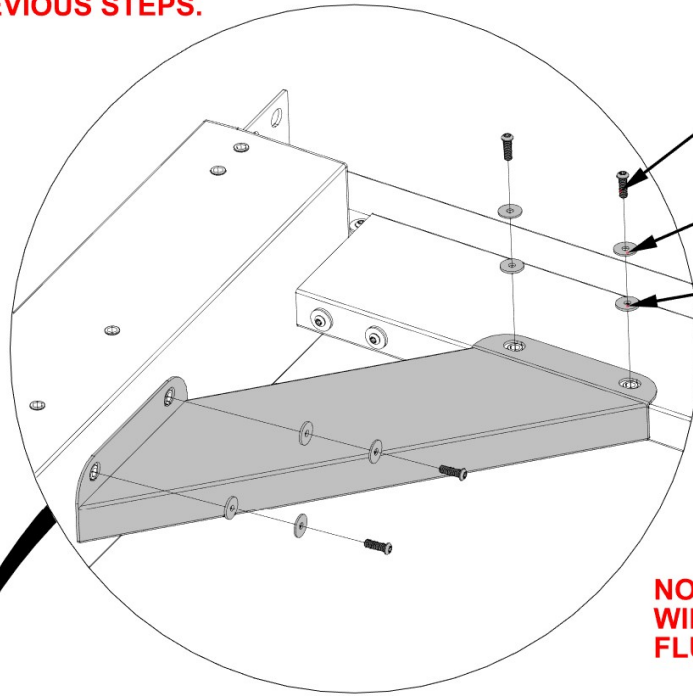

1101 (x8)
TORX PAN HEAD 1/4-20x3/4"

1053 (x8)
STEEL WASHER 6x20

1054 (x8)
SEALANT WASHER

**NOTE: CORBEL BRACKET HOLES
WILL FIT AROUND NUT ZERTS AND
FLUSH AGAINST BEAM AND POST**

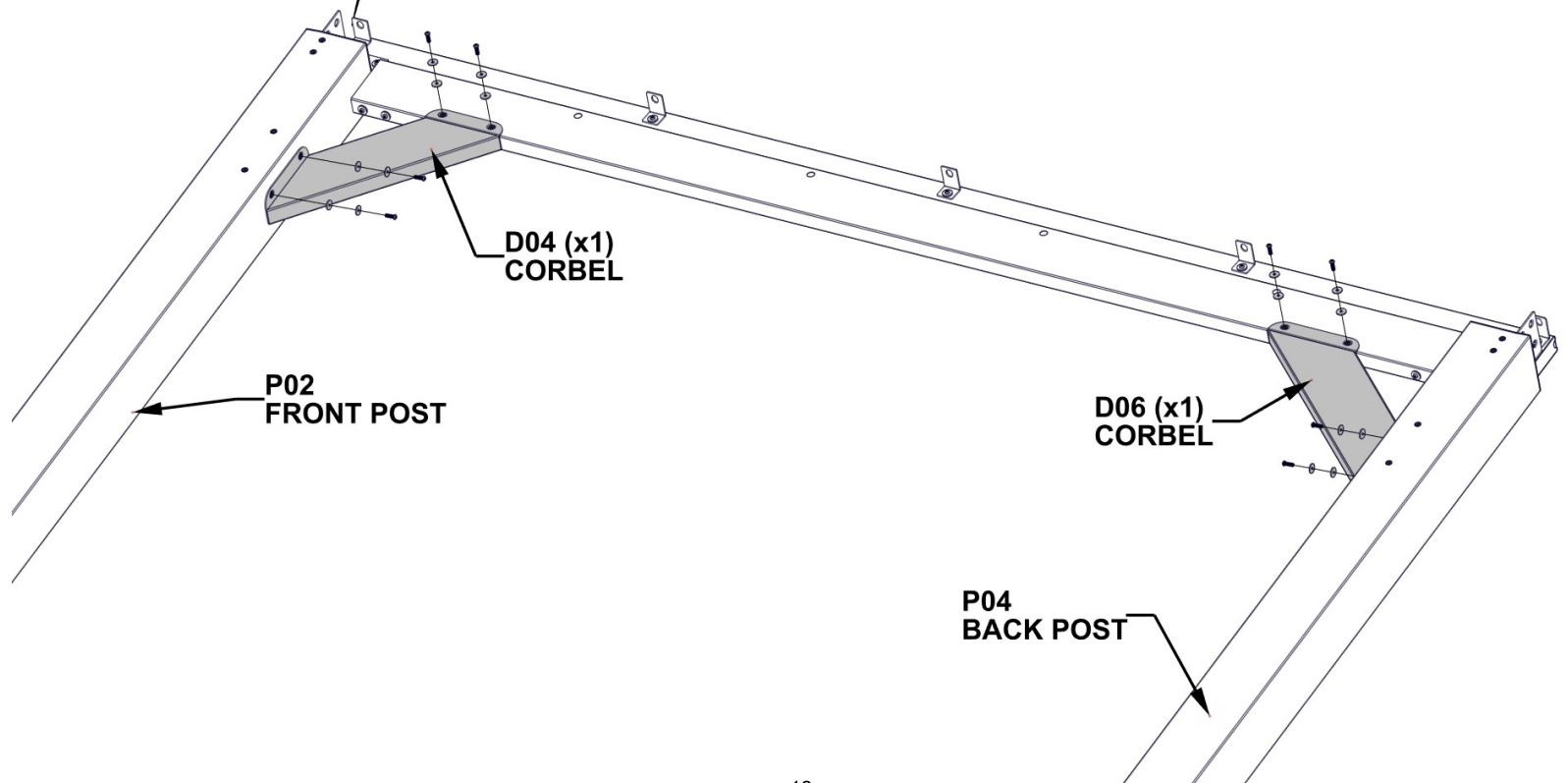

STEP 7 - LEFT SIDE POST ASSEMBLY

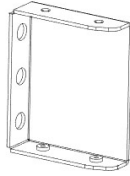

A4M01814 BEAM BRACKET
(x2)

Qty	PART NUMBER	Description
4	H101054	SEALANT WASHER
4	H101101	TORX PAN HEAD 1/4-20x3/4"
4	H101053	STEEL WASHER 6x20

- 1101 (x4)
TORX PAN HEAD 1/4-20x3/4"
- 1053 (x4)
STEEL WASHER 6x20
- 1054 (x4)
SEALANT WASHER
- 1814 (x2)
BEAM BRACKET

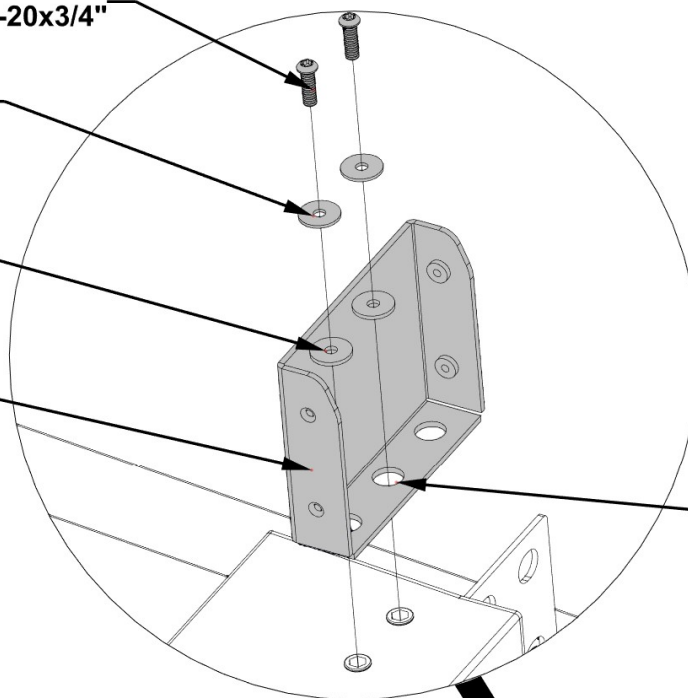

NOTE: BOTTOM TWO HOLES OF BRACKET WILL FIT AROUND NUT ZERT AND FLUSH AGAINST POST

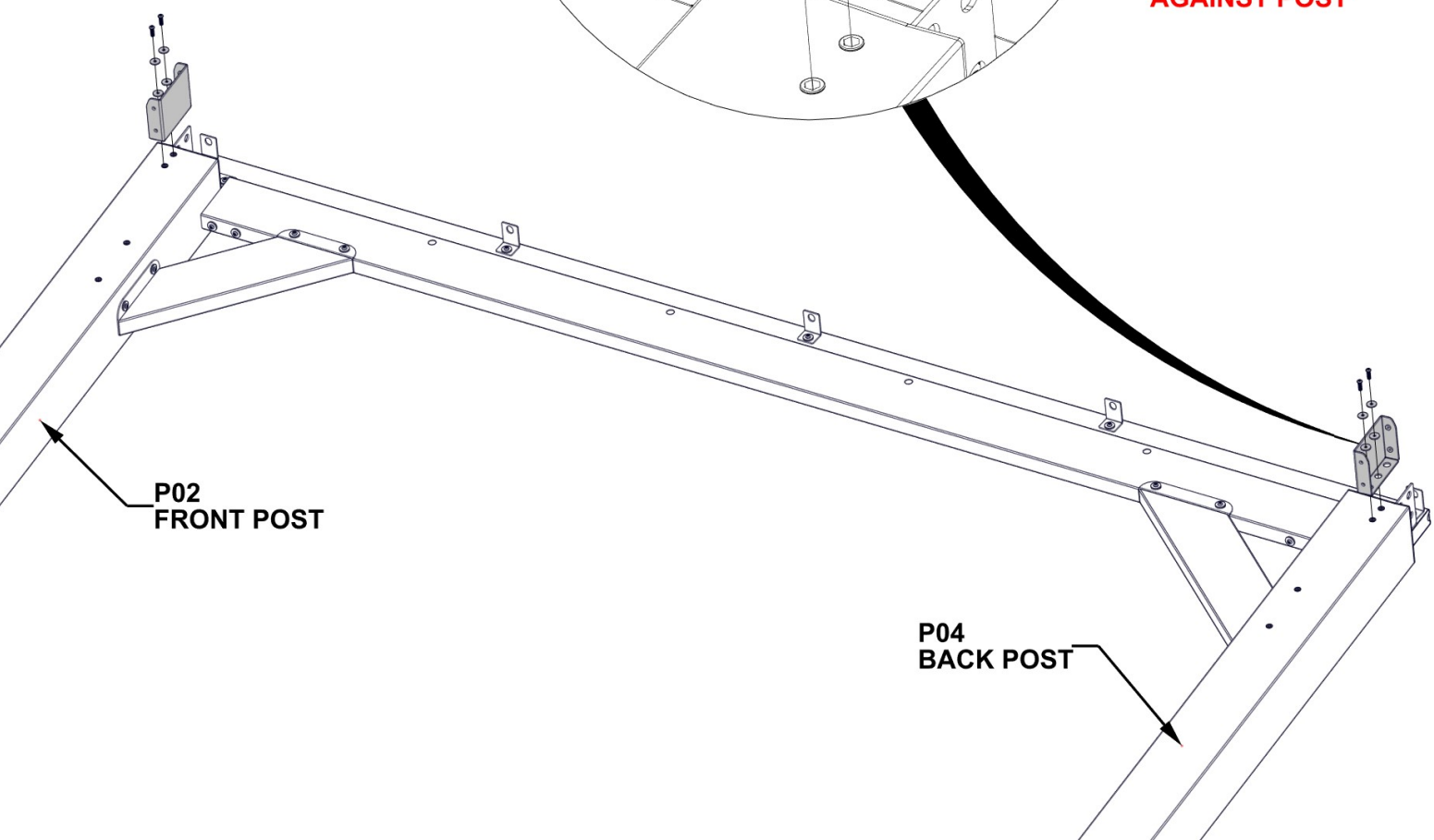

P02
FRONT POST

P04
BACK POST

STEP 8 - MIDDLE POST ASSEMBLY

Qty	PART NUMBER	Description
6	H101103	TORX SOCKET SCREW 1/4-20

P05 POST - A4M01970
(x1) 5 1/2"x8"x96 15/16" (140x202x2462)

P06 POST - A4M01971
(x1) 5 1/2"x8"x87 5/8" (140x202x2225)

B12 MIDDLE BEAM - A4M01972
(x1) 1 3/8"5 1/4"x111 3/4" (36x134x2837)

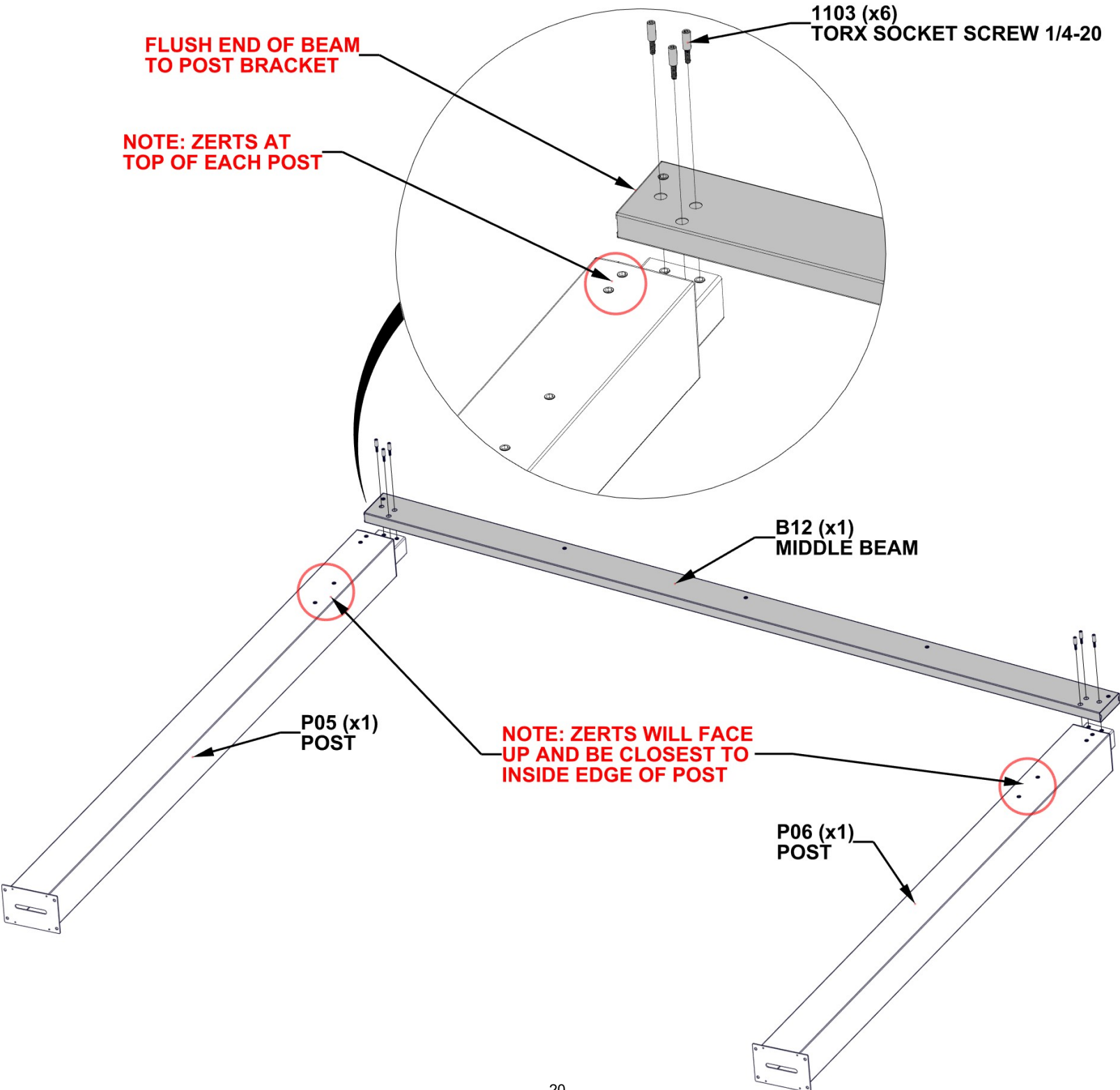

STEP 9 - MIDDLE POST ASSEMBLY

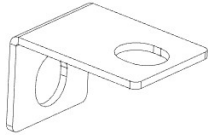

A4M01844 PURLIN BRACKET
(x5)

Qty	PART NUMBER	Description
5	H101101	TORX PAN HEAD 1/4-20x3/4"
5	H101053	STEEL WASHER 6x20
5	H101054	SEALANT WASHER

DO NOT FULLY TIGHTEN BOLTS AT THIS STEP

NOTE: BRACKET HOLE WILL FIT AROUND NUT ZERT AND FLUSH AGAINST BEAM

1101 (x5)
TORX PAN HEAD 1/4-20x3/4"

1053 (x5)
STEEL WASHER 6x20

1054 (x5)
SEALANT WASHER

1844 (x5)
PURLIN BRACKET

NOTE: SHORT SIDE OF BRACKET AGAINST BEAM

P05
POST

P06
POST

STEP 10 - MIDDLE POST ASSEMBLY



A4M01352 HOLE COVER
(x6)

USE A SMALL PIECE OF WOOD AND RUBBER Mallet TO TAP HOLE COVERS IN.

DO NOT TAP DIRECTLY WITH A HAMMER AS YOU MAY DAMAGE THE POWDER COAT FINISH ON PRODUCT.

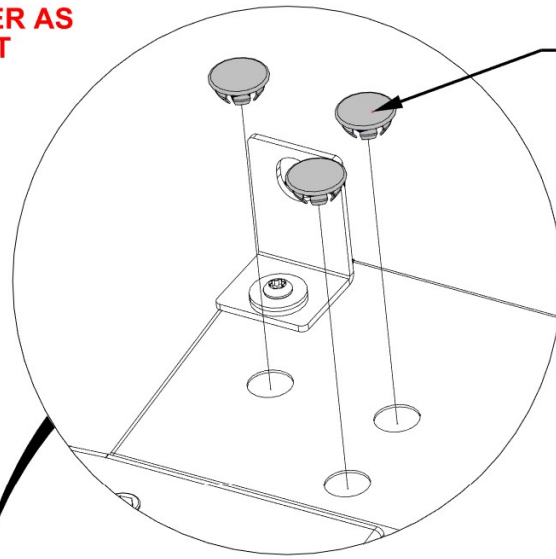

H1 (x6)
HOLE COVER

P05
POST

P06
POST

STEP 11 - MIDDLE POST ASSEMBLY



A4M01814 BEAM BRACKET
(x2)

Qty	PART NUMBER	Description
4	H101053	STEEL WASHER 6x20
4	H101054	SEALANT WASHER
4	H101101	TORX PAN HEAD 1/4-20x3/4"

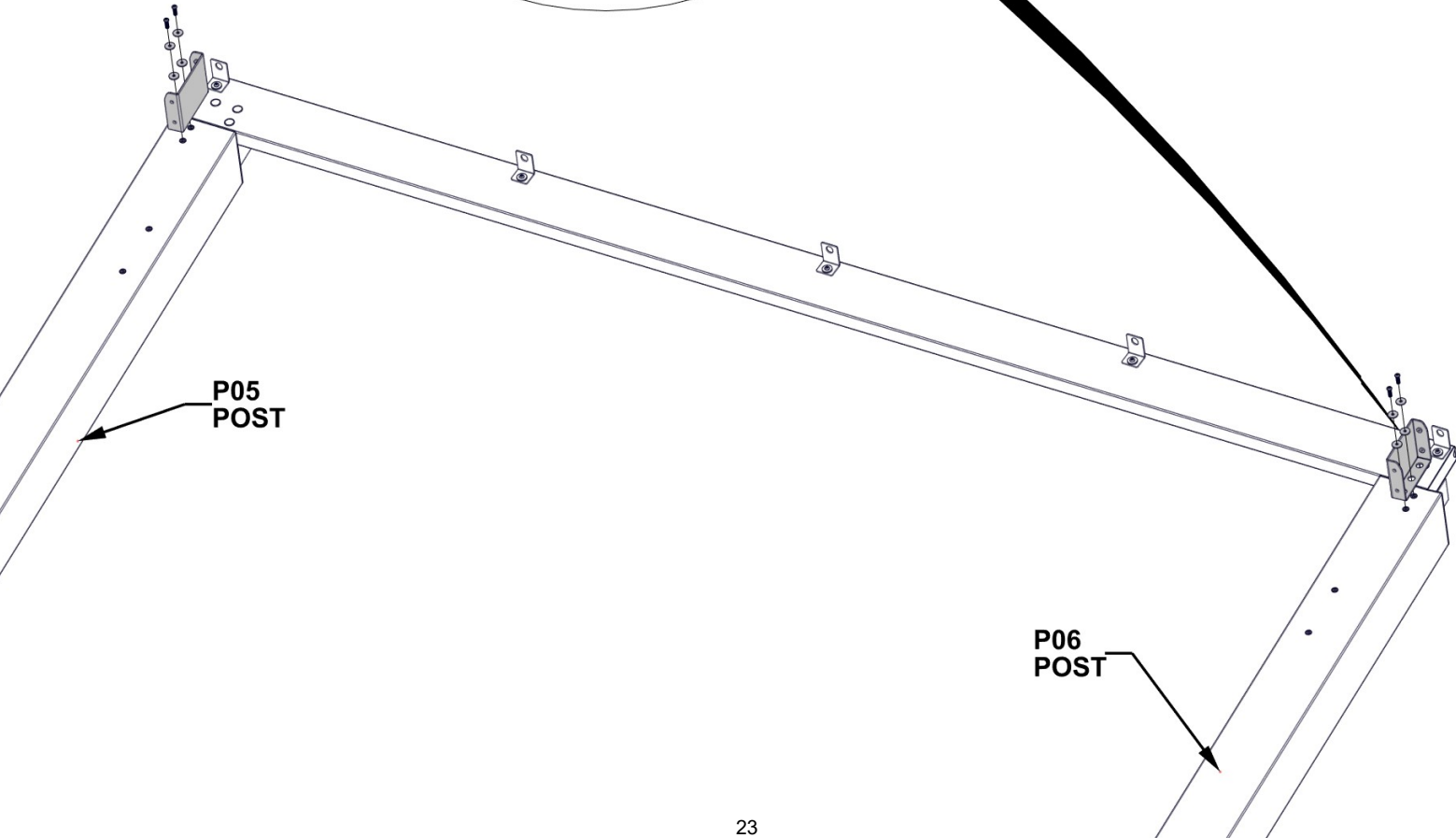
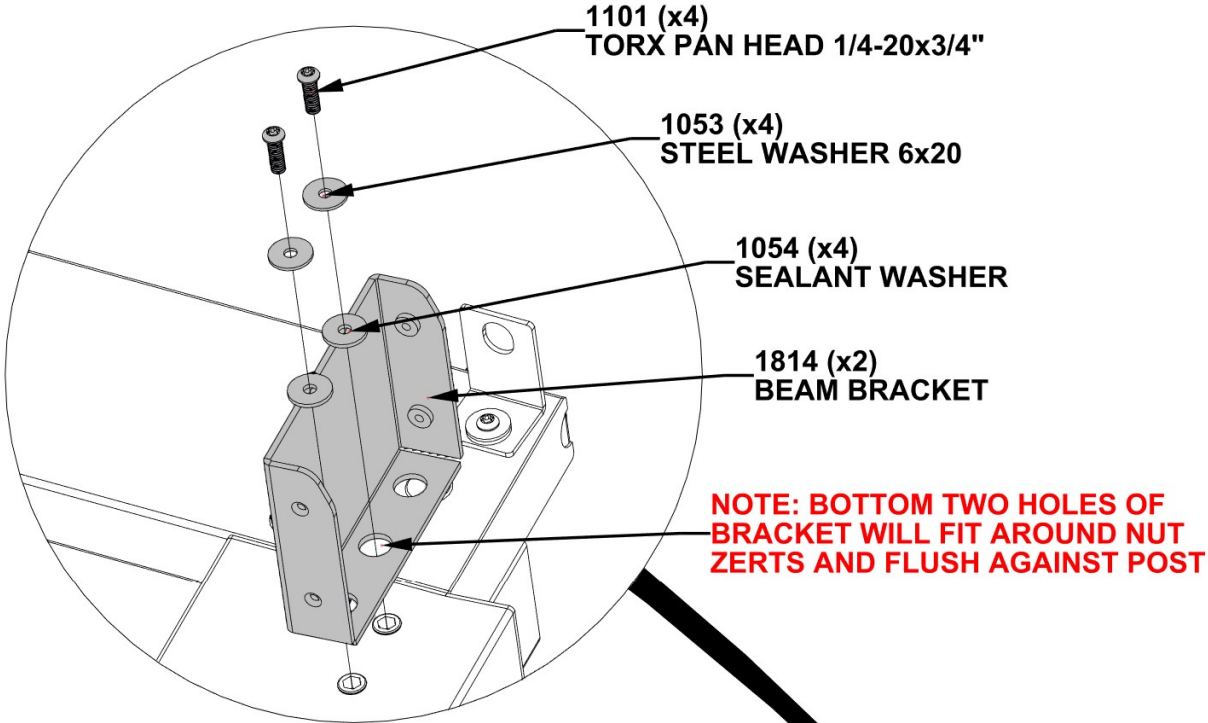

STEP 12 - MIDDLE POST ASSEMBLY

Qty	PART NUMBER	Description
6	H101103	TORX SOCKET SCREW 1/4-20



B13 MIDDLE BEAM - A4M01973
(x1) 1 3/8"x5 1/4"x111 3/4" (36x134x2837)

**FLIP MIDDLE POST ASSEMBLY
OVER AND ATTACH B13 TO POST**

**FLUSH END OF BEAM
TO POST BRACKET**

**NOTE: ZERTS AT
TOP OF EACH POST**

**1103 (x6)
TORX SOCKET SCREW 1/4-20**

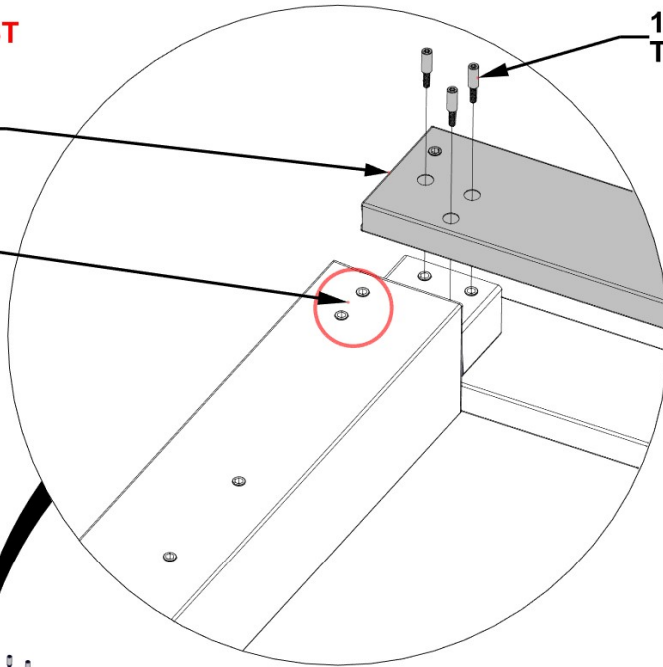

**B13 (x1)
MIDDLE BEAM**

**P06
POST**

**NOTE: ZERTS WILL FACE
UP AND BE CLOSEST TO
INSIDE EDGE OF POST**

**P05
POST**

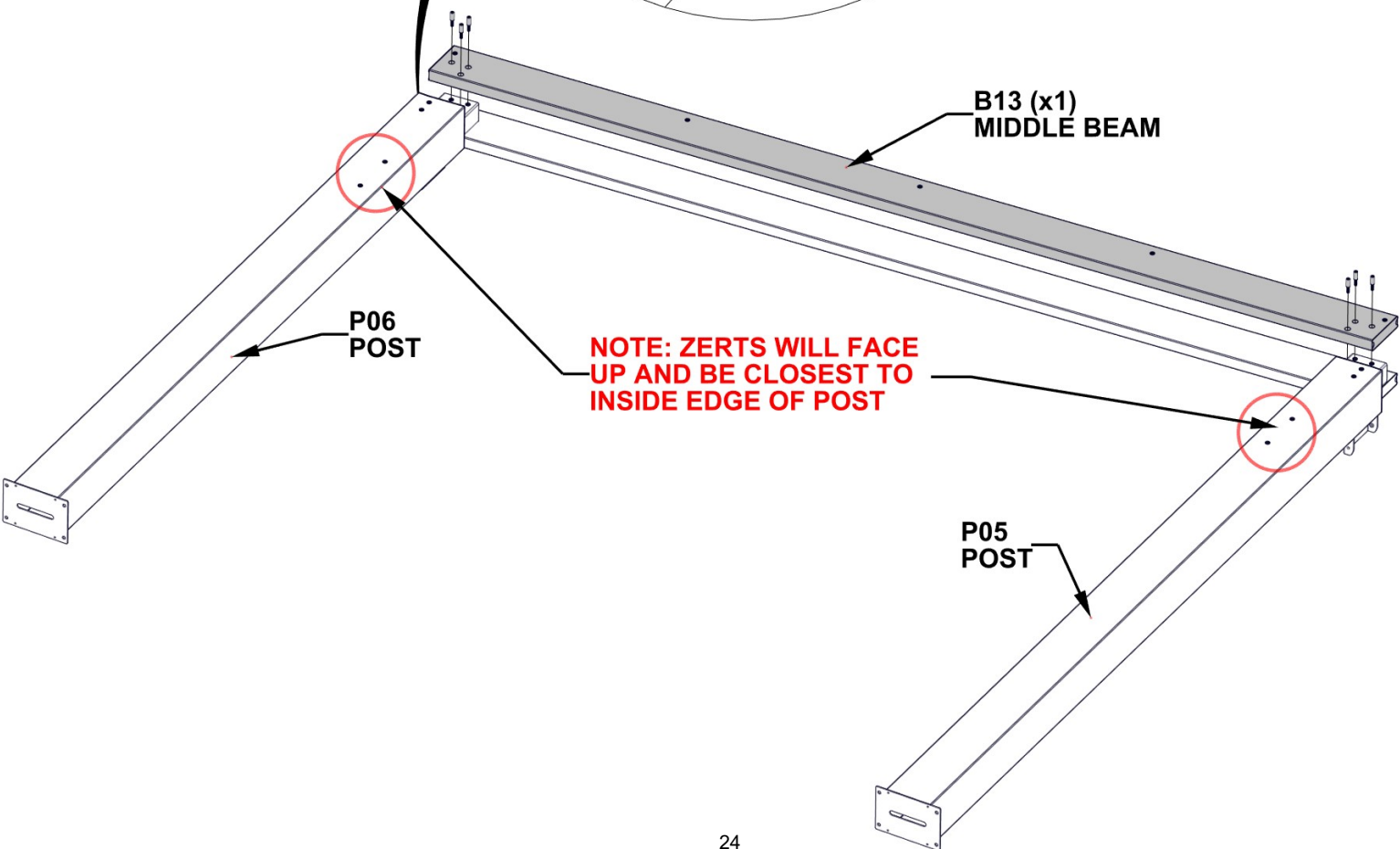

STEP 13 - MIDDLE POST ASSEMBLY

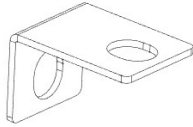

A4M01844 PURLIN BRACKET
(x5)

Qty	PART NUMBER	Description
5	H101101	TORX PAN HEAD 1/4-20x3/4"
5	H101053	STEEL WASHER 6x20
5	H101054	SEALANT WASHER

DO NOT FULLY TIGHTEN BOLTS AT THIS STEP

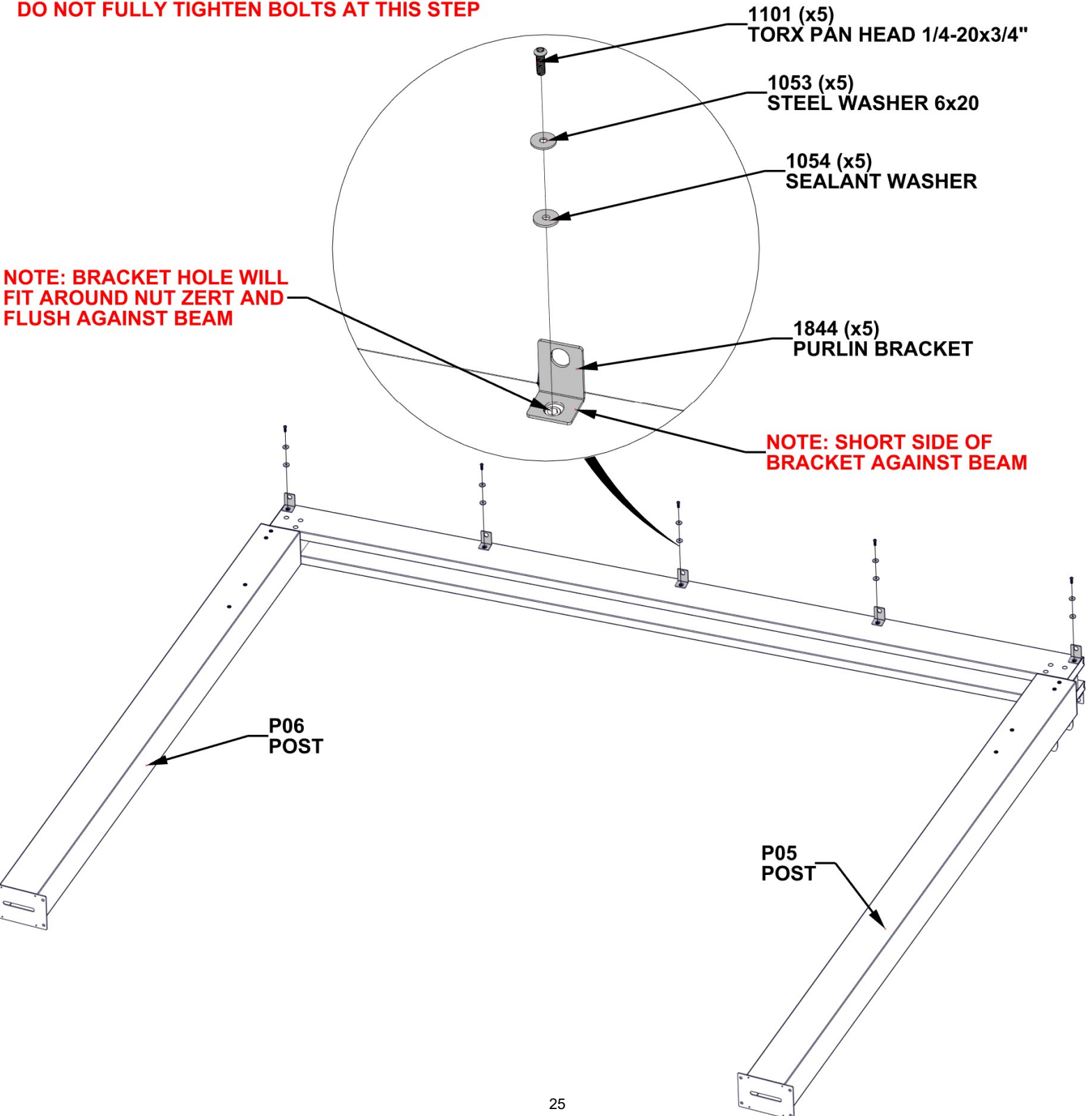

STEP 14 - MIDDLE POST ASSEMBLY



A4M01352 HOLE COVER
(x6)

USE A SMALL PIECE OF WOOD AND RUBBER Mallet TO TAP HOLE COVERS IN.

DO NOT TAP DIRECTLY WITH A HAMMER AS YOU MAY DAMAGE THE POWDER COAT FINISH ON PRODUCT.

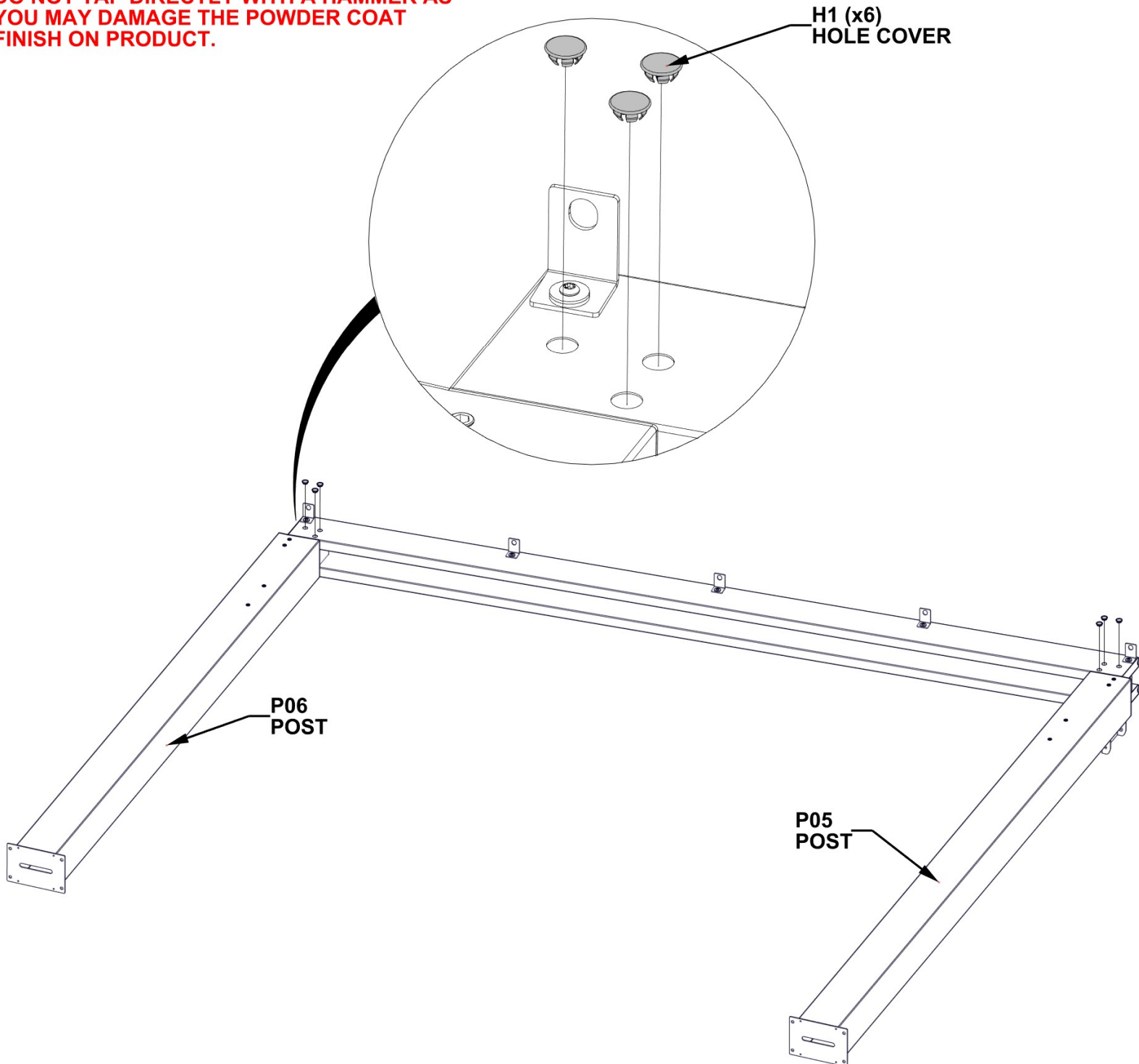

STEP 15 - MIDDLE POST ASSEMBLY



A4M01814 BEAM BRACKET
(x2)

Qty	PART NUMBER	Description
4	H101101	TORX PAN HEAD 1/4-20x3/4"
4	H101053	STEEL WASHER 6x20
4	H101054	SEALANT WASHER

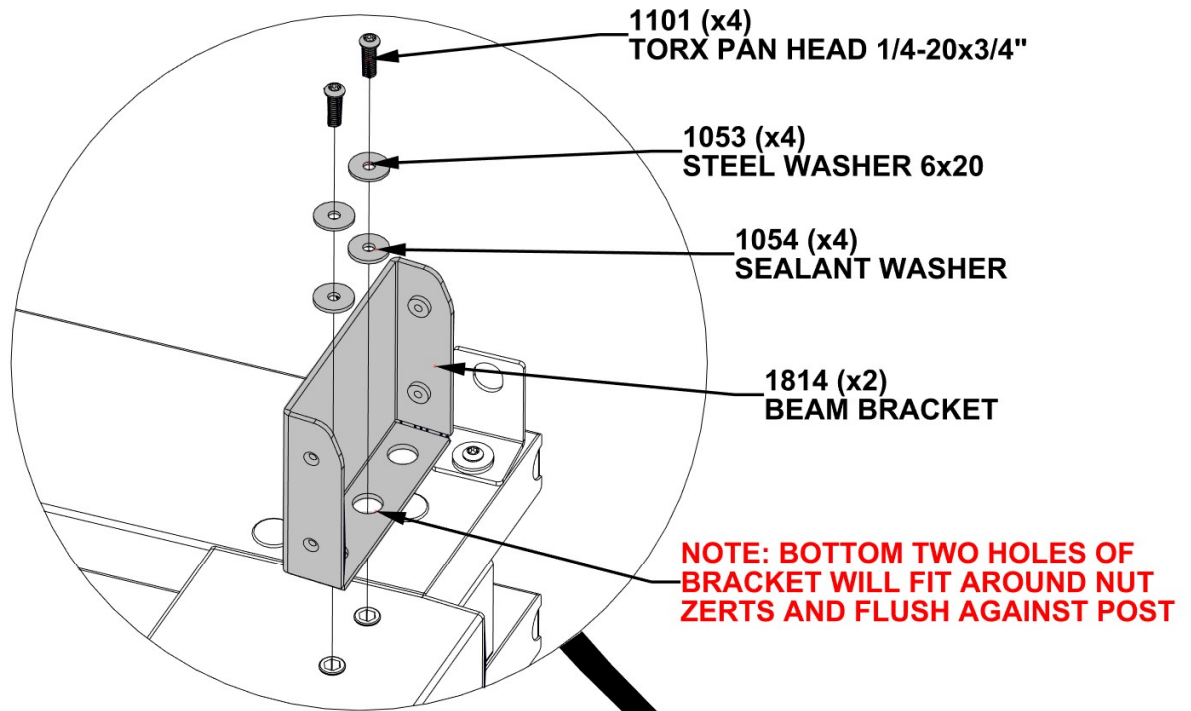

P06
POST

P05
POST

STEP 16 - FRONT BEAM ASSEMBLY

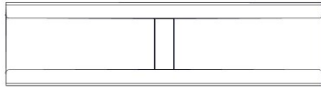

J1 SPLICE BRACKET - A4M01980
(x1) 1 5/16"x5 3/16"x19 11/16" (33.2x131x500)

Qty	PART NUMBER	Description
6	H101054	SEALANT WASHER
6	H101101	TORX PAN HEAD 1/4-20x3/4"
6	H101053	STEEL WASHER 6x20



B11 BEAM - A4M01967
(x1) 1 3/8"x5 1/4"x76 1/4" (36x134x1936)

DO NOT FULLY TIGHTEN BOLTS AT THIS STEP

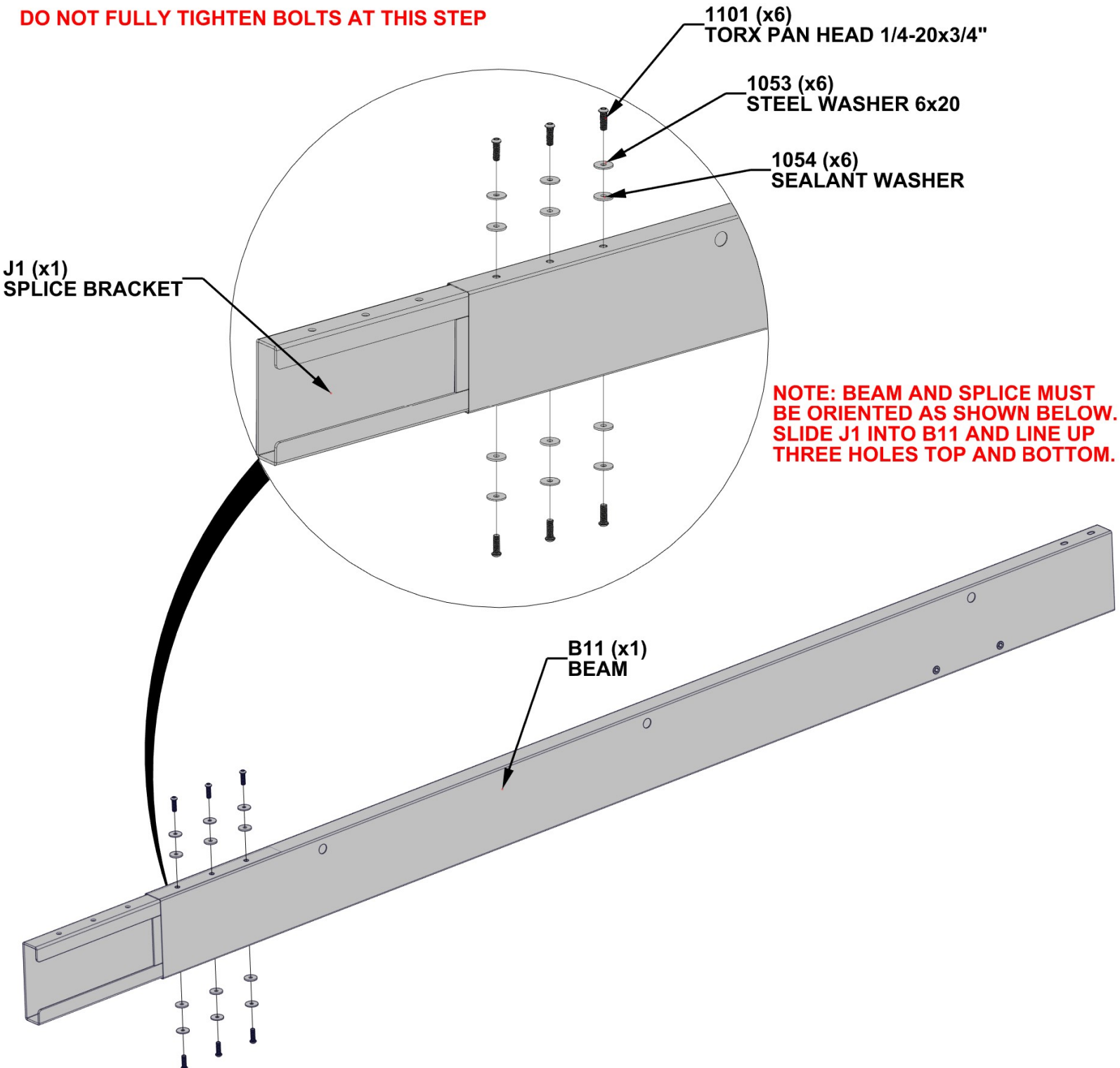

STEP 17 - FRONT BEAM ASSEMBLY



B10 BEAM - A4M01968
 (x1) 1 3/8"x5 1/4"x38 1/8" (36x134x969)

Qty	PART NUMBER	Description
6	H101101	TORX PAN HEAD 1/4-20x3/4"
6	H101053	STEEL WASHER 6x20
6	H101054	SEALANT WASHER

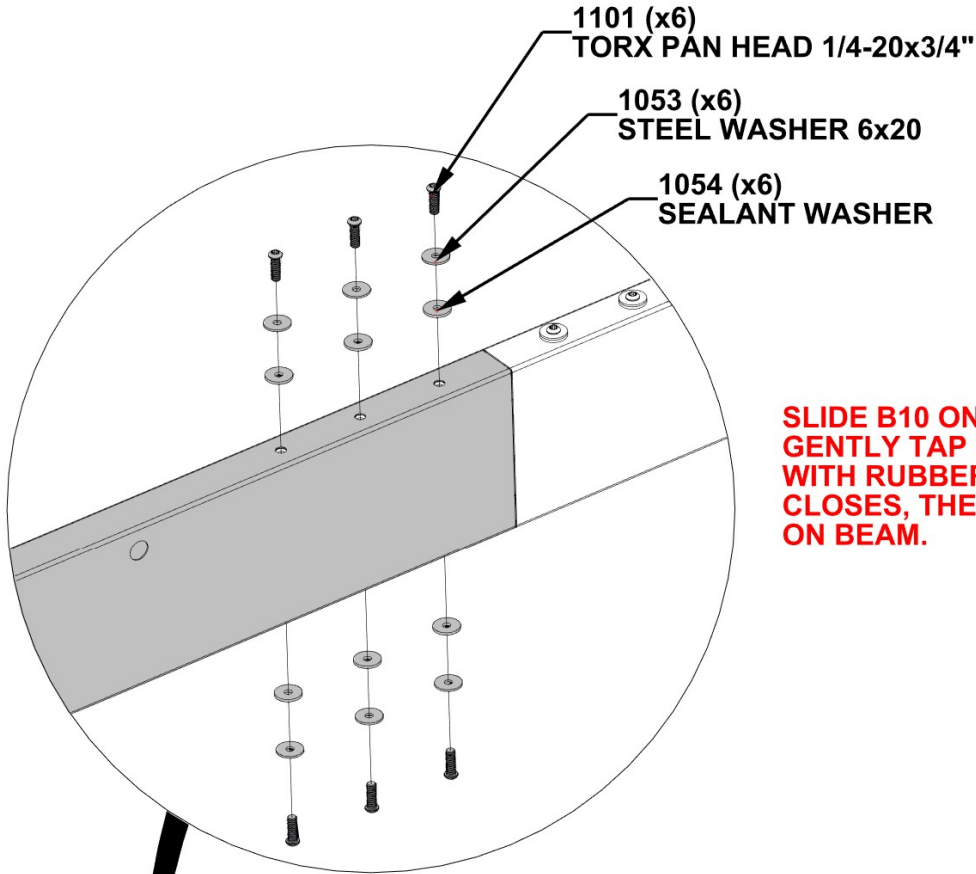

SLIDE B10 ONTO SPLICE BRACKET. GENTLY TAP ENDS OF ASSEMBLY WITH RUBBER Mallet UNTIL GAP CLOSES, THEN TIGHTEN ALL BOLTS ON BEAM.

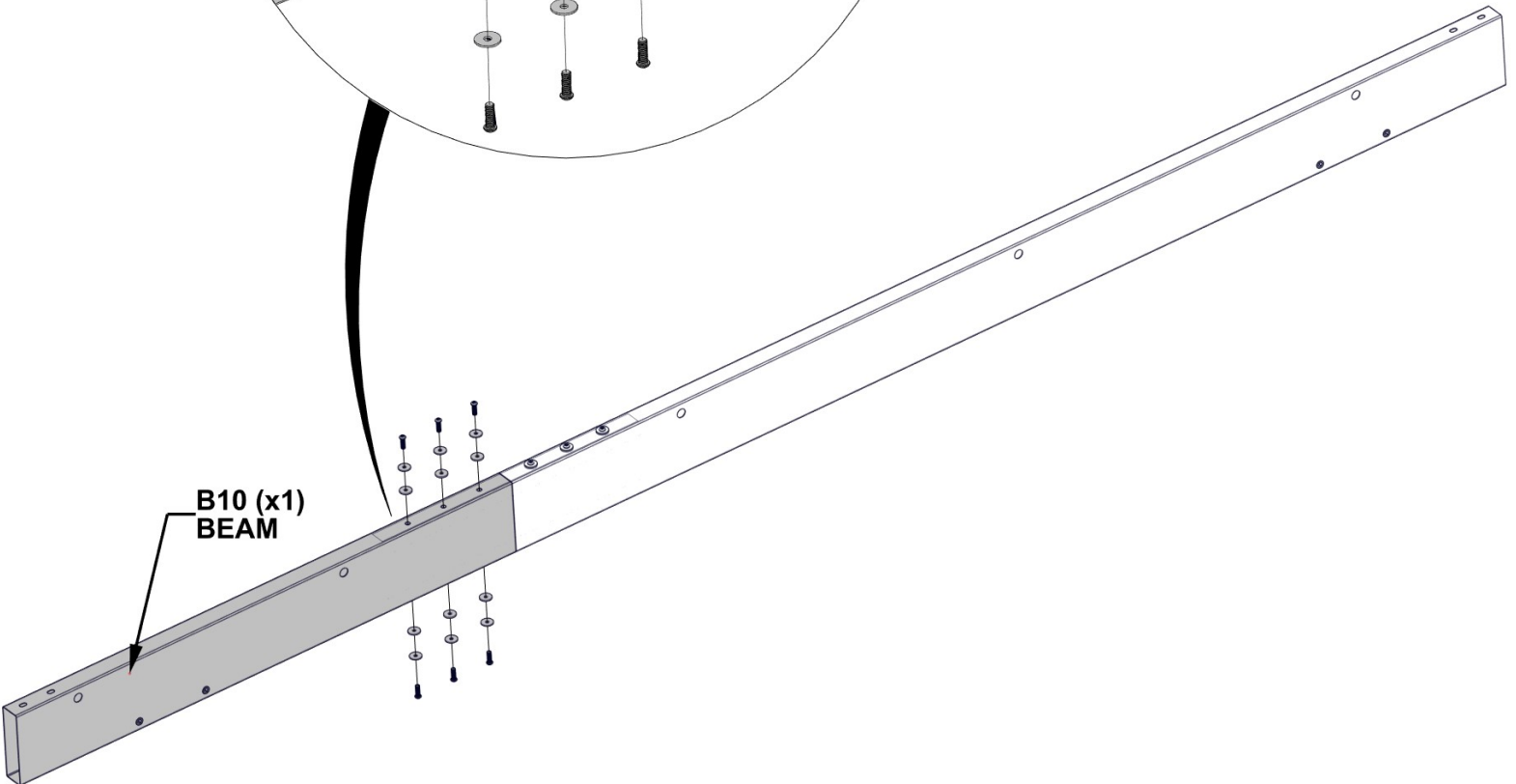

STEP 18 - FRONT BEAM ASSEMBLY

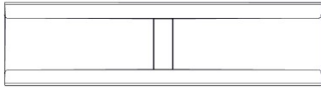

J1 SPLICE BRACKET - A4M01980
(x1) 1 5/16"x5 3/16"x19 11/16" (33.2x131x500)

Qty	PART NUMBER	Description
6	H101101	TORX PAN HEAD 1/4-20x3/4"
6	H101053	STEEL WASHER 6x20
6	H101054	SEALANT WASHER



B03 BEAM - A4M01964
(x1) 1 3/8"x5 1/4"x81 7/8" (36x134x2080)

DO NOT FULLY TIGHTEN BOLTS AT THIS STEP

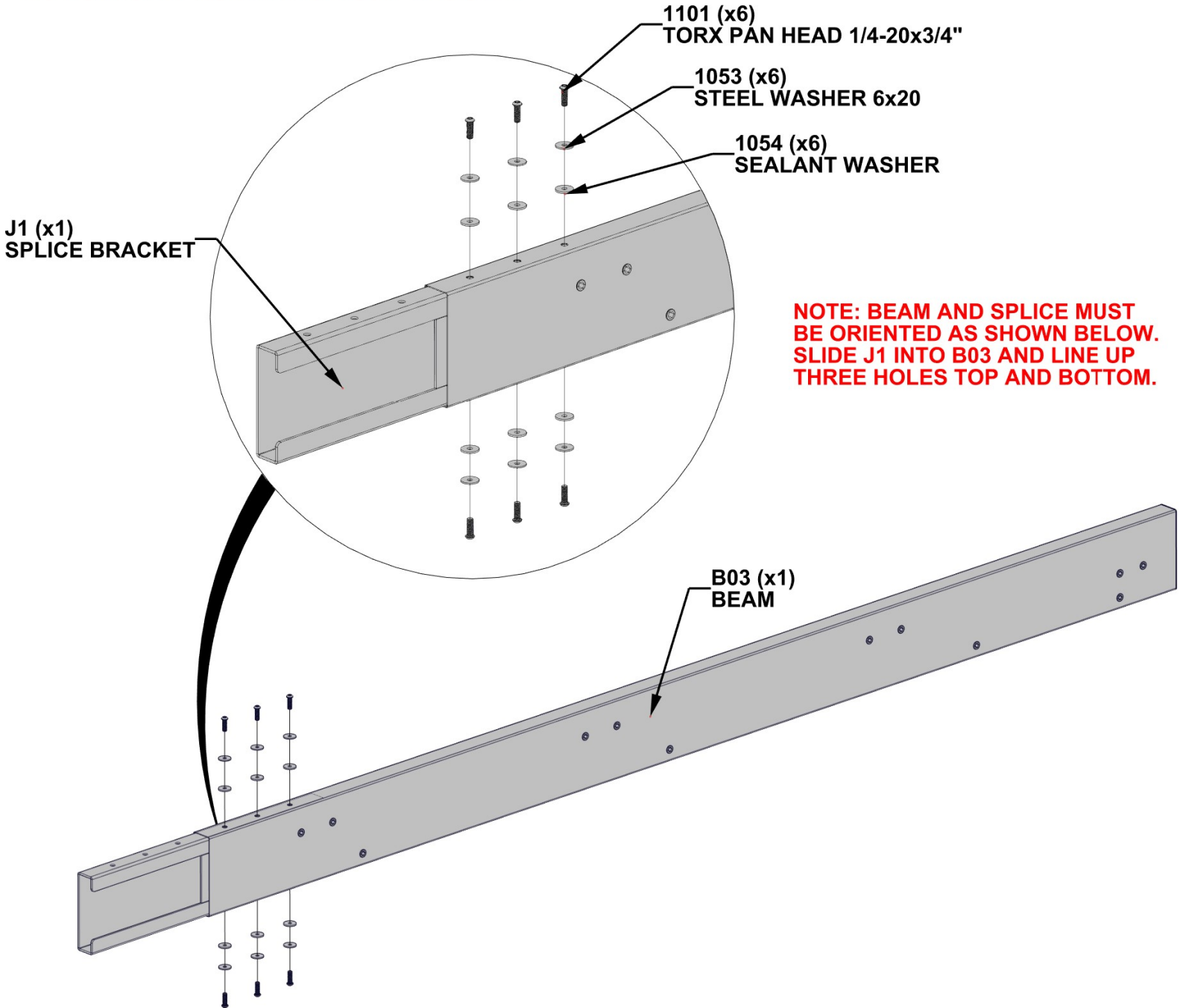

STEP 19 - FRONT BEAM ASSEMBLY



B02 BEAM - A4M01965
 (x1) 1 3/8"x5 1/4"x81 7/8" (36x134x2079)

Qty	PART NUMBER	Description
6	H101054	SEALANT WASHER
6	H101101	TORX PAN HEAD 1/4-20x3/4"
6	H101053	STEEL WASHER 6x20

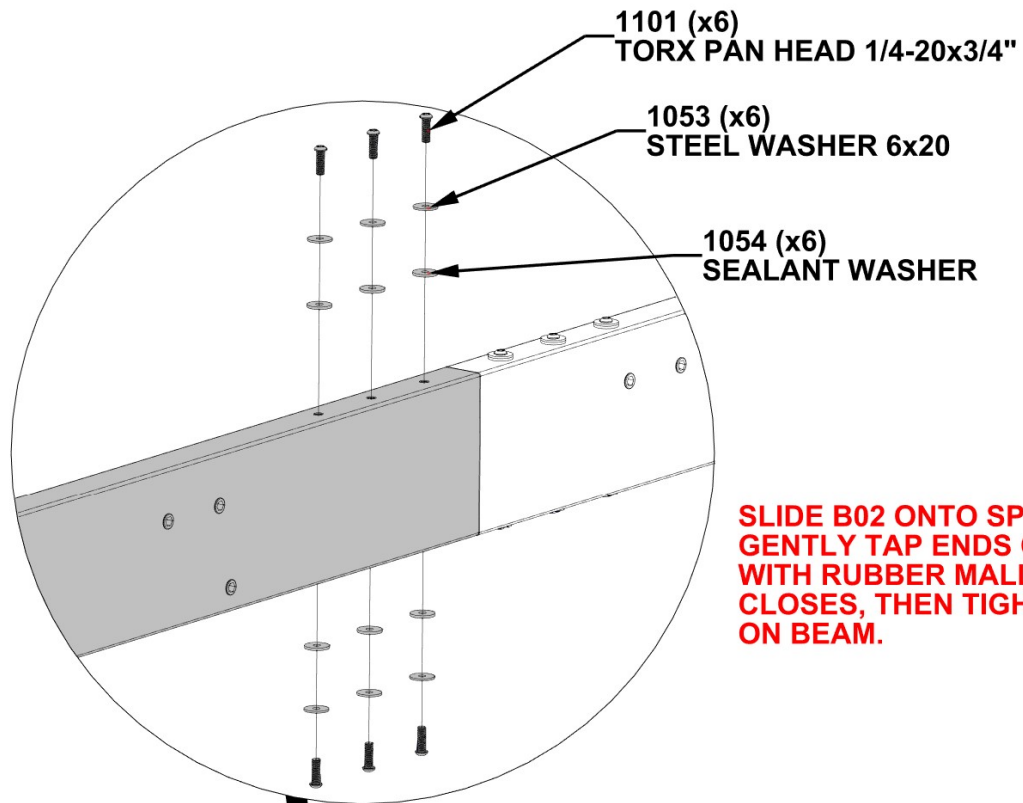

**SLIDE B02 ONTO SPLICE BRACKET.
 GENTLY TAP ENDS OF ASSEMBLY
 WITH RUBBER Mallet UNTIL GAP
 CLOSES, THEN TIGHTEN ALL BOLTS
 ON BEAM.**

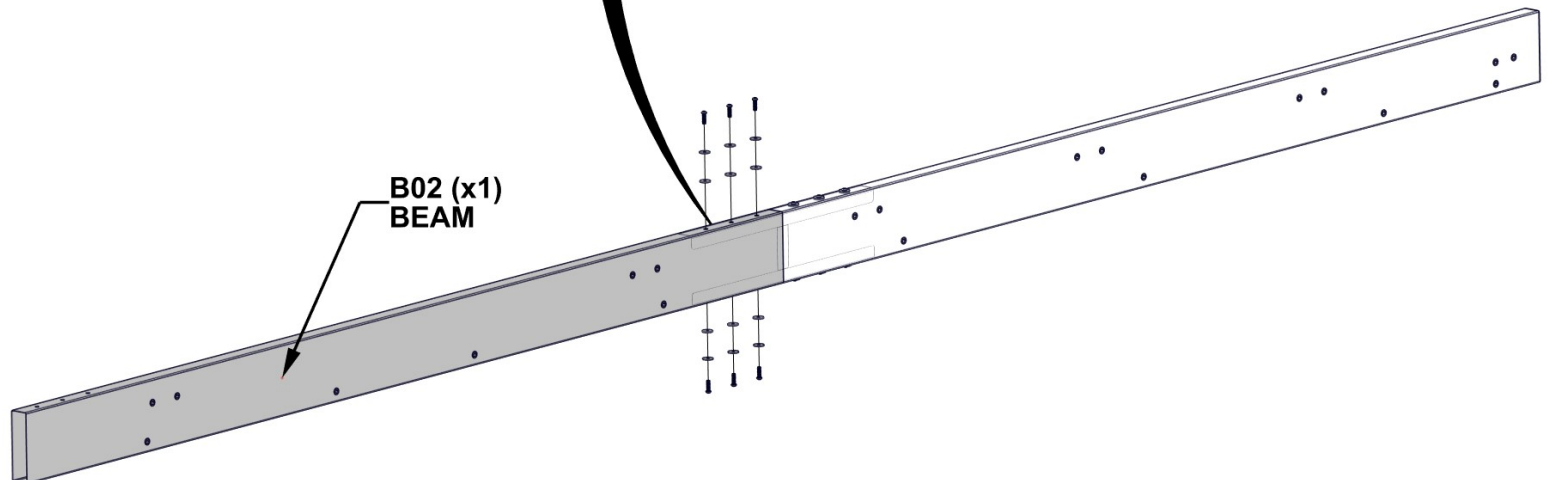

STEP 20 - FRONT BEAM ASSEMBLY



J1 SPLICE BRACKET - A4M01980
 (x1) 1 5/16"x5 3/16"x19 11/16" (33.2x131x500)

Qty	PART NUMBER	Description
6	H101101	TORX PAN HEAD 1/4-20x3/4"
6	H101053	STEEL WASHER 6x20
6	H101054	SEALANT WASHER

DO NOT FULLY TIGHTEN BOLTS AT THIS STEP

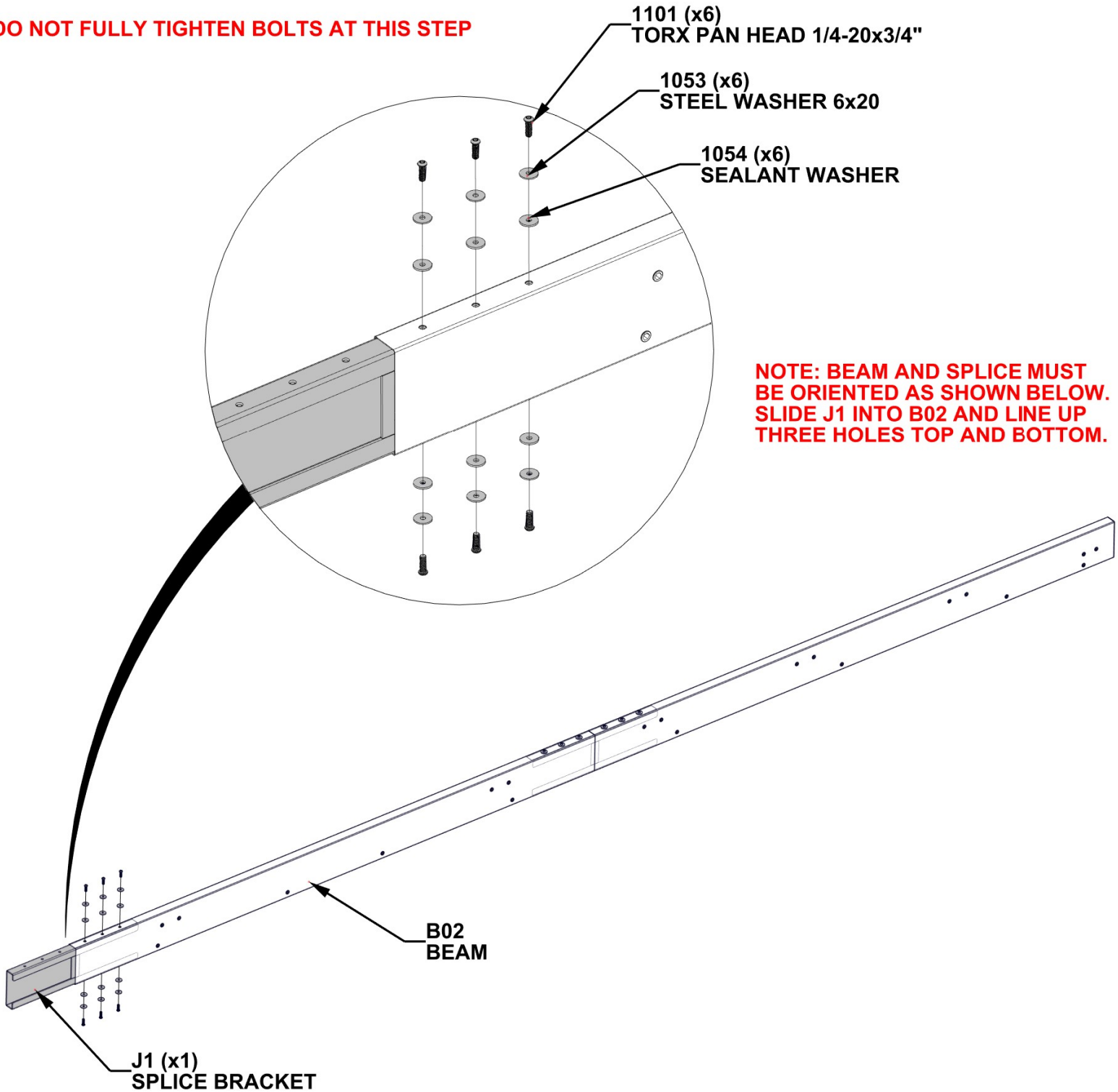

STEP 21 - FRONT BEAM ASSEMBLY

Qty	PART NUMBER	Description
5	H101103	TORX SOCKET SCREW 1/4-20



FRONT BEAM ASSEMBLY STEPS 16-17



FRONT BEAM ASSEMBLY STEPS 18-20

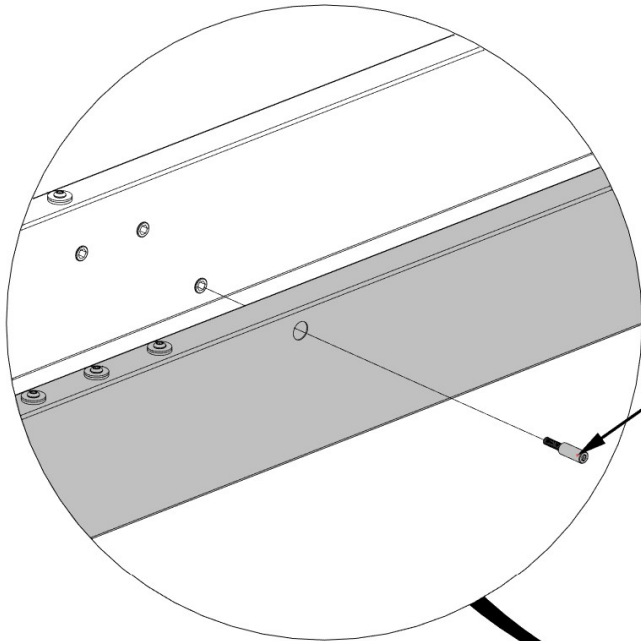

ALIGN THRU HOLES IN BEAM ASSEMBLY STEPS 16-17 WITH ZERTS IN BEAM ASSEMBLY STEPS 18-20.

**1103 (x5)
TORX SOCKET SCREW 1/4-20**

**FRONT BEAM
ASSEMBLY STEPS 16-17**

**FRONT BEAM ASSEMBLY
STEPS 18-20**

FRONT VIEW

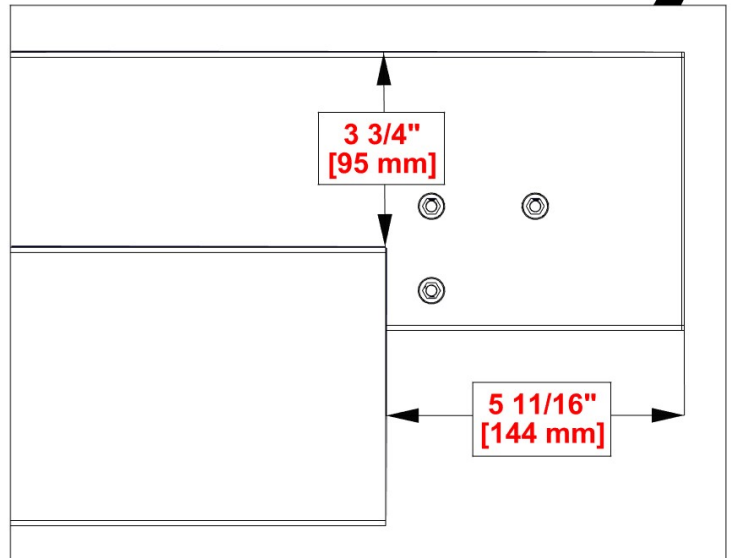

**DIMENSIONS ARE CRITICAL
TO THE BEAM ASSEMBLY**

**3 3/4" [95mm] DIMENSION IS
CRITICAL ALONG ENTIRE
LENGTH OF BEAM**

STEP 22 - FRONT BEAM ASSEMBLY

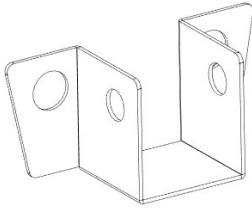

A4M01834 RAFTER BRACKET
(x5)

Qty	PART NUMBER	Description
10	H101053	STEEL WASHER 6x20
10	H101054	SEALANT WASHER
10	H101101	TORX PAN HEAD 1/4-20x3/4"

NOTE: BRACKET HOLE WILL FIT AROUND NUT ZERT AND FLUSH AGAINST BEAM

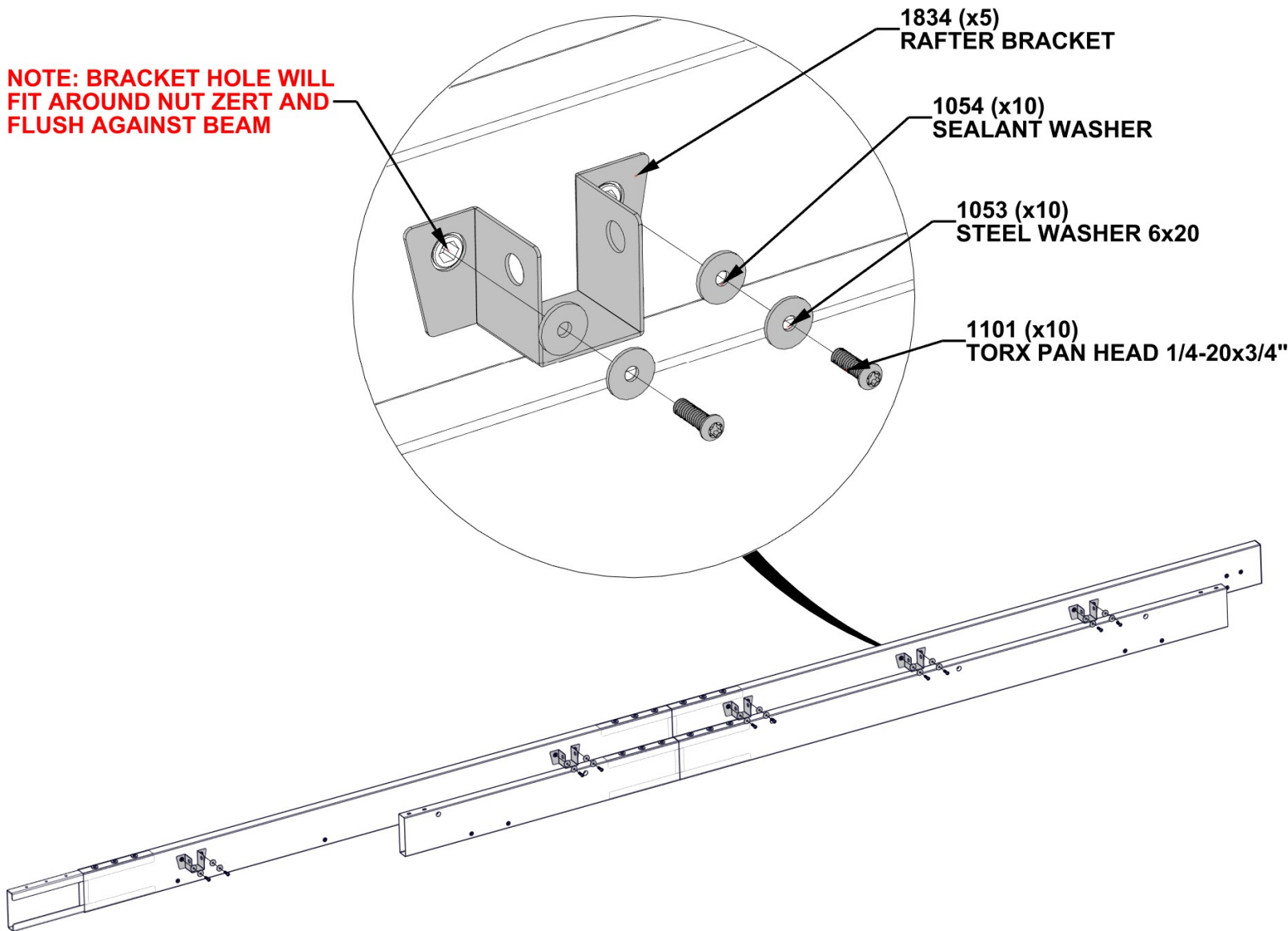

STEP 23 - BACK BEAM ASSEMBLY

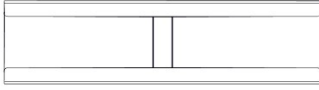

J1 SPLICE BRACKET - A4M01980
 (x1) 1 5/16"x5 3/16"x19 11/16" (33.2x131x500)

Qty	PART NUMBER	Description
6	H101054	SEALANT WASHER
6	H101101	TORX PAN HEAD 1/4-20x3/4"
6	H101053	STEEL WASHER 6x20



B04 BEAM - A4M01966
 (x1) 1 3/8"x5 1/4"x76 1/4" (36x134x1936)

DO NOT FULLY TIGHTEN BOLTS AT THIS STEP

1101 (x6)
 TORX PAN HEAD 1/4-20x3/4"

1053 (x6)
 STEEL WASHER 6x20

1054 (x6)
 SEALANT WASHER

J1 (x1)
 SPLICE BRACKET

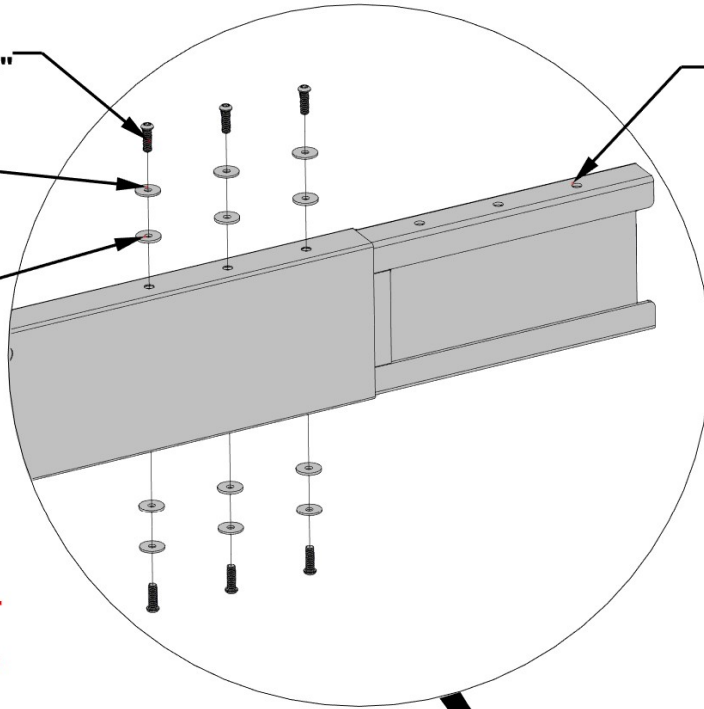

NOTE: BEAM AND SPLICE MUST BE ORIENTED AS SHOWN BELOW. SLIDE J1 INTO B04 AND LINE UP THREE HOLES TOP AND BOTTOM.

B04 (x1)
 BEAM

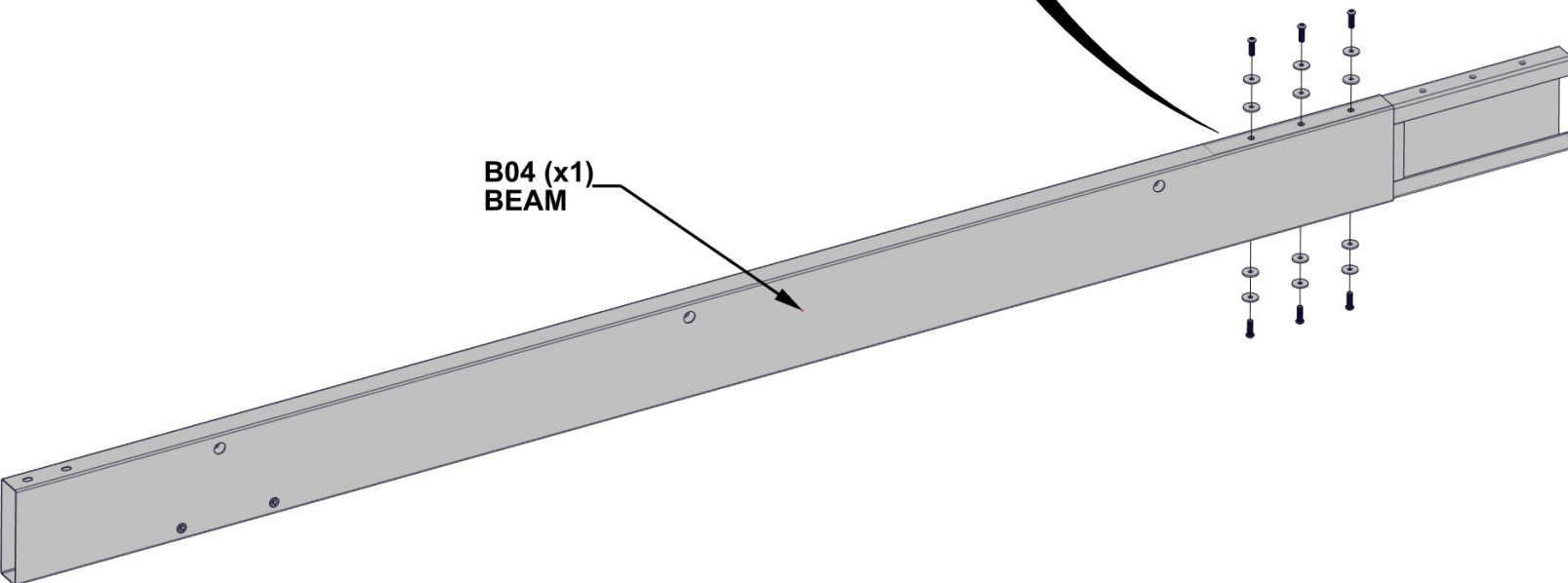

STEP 24 - BACK BEAM ASSEMBLY



B09 BEAM - A4M01969
 (x1) 1 3/8"x5 1/4"x38 1/8" (36x134x969)

Qty	PART NUMBER	Description
6	H101101	TORX PAN HEAD 1/4-20x3/4"
6	H101053	STEEL WASHER 6x20
6	H101054	SEALANT WASHER

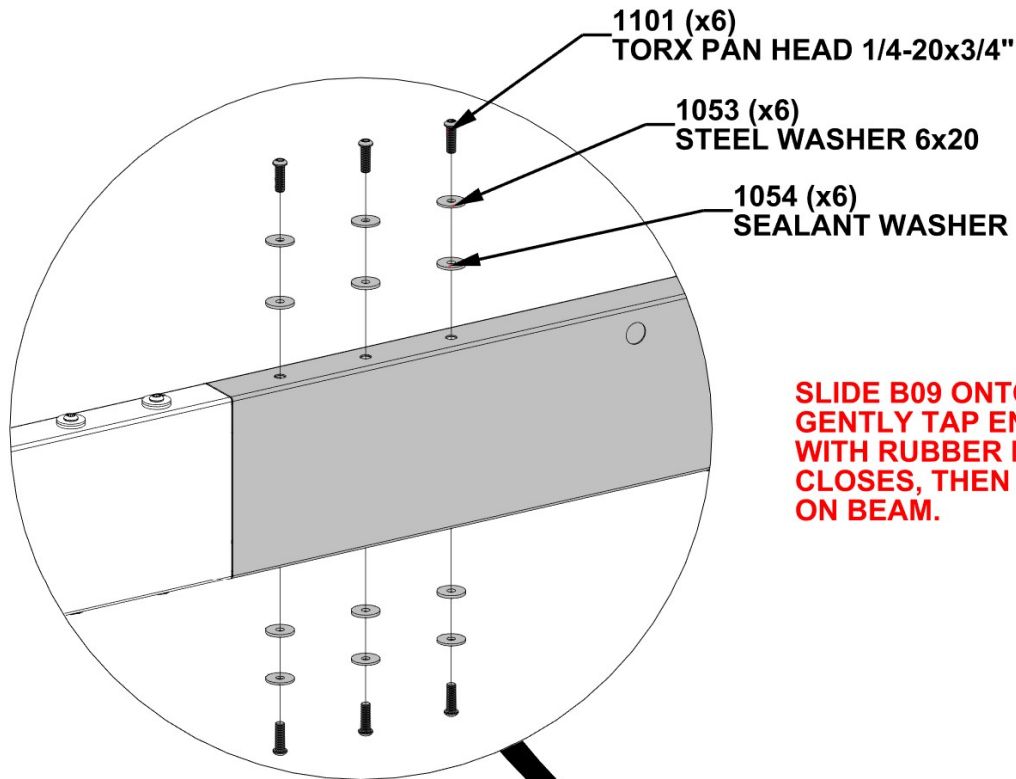

**SLIDE B09 ONTO SPLICE BRACKET.
 GENTLY TAP ENDS OF ASSEMBLY
 WITH RUBBER Mallet UNTIL GAP
 CLOSES, THEN TIGHTEN ALL BOLTS
 ON BEAM.**

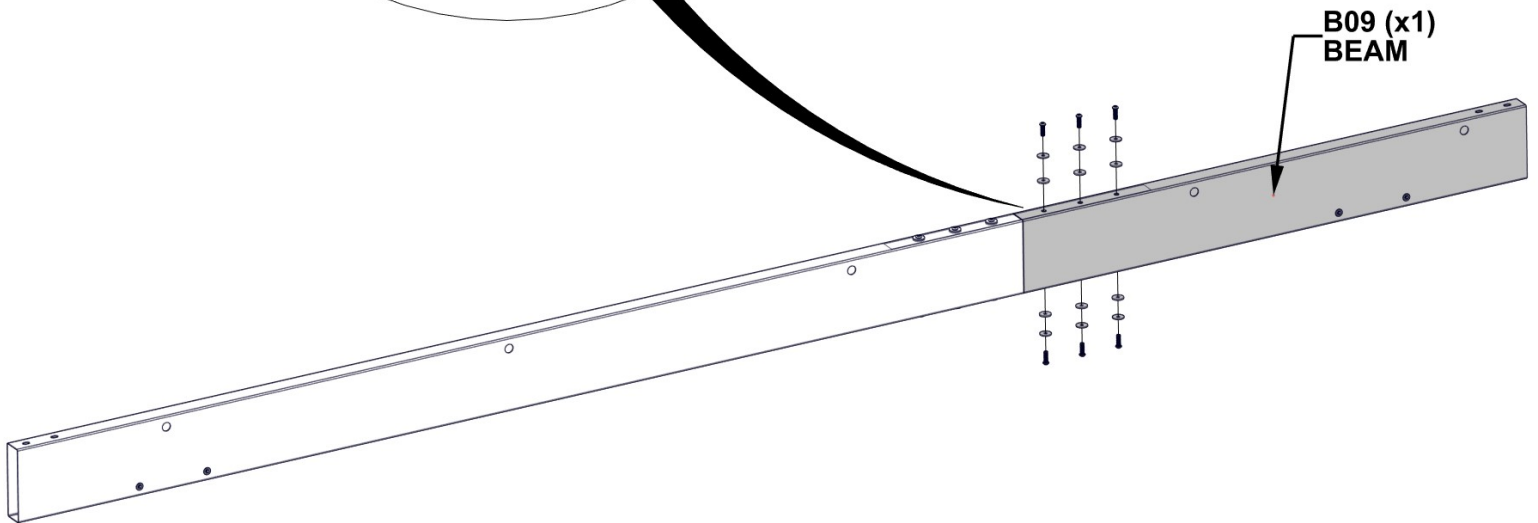

STEP 25 - BACK BEAM ASSEMBLY

Qty	PART NUMBER	Description
6	H101054	SEALANT WASHER
6	H101101	TORX PAN HEAD 1/4-20x3/4"
6	H101053	STEEL WASHER 6x20

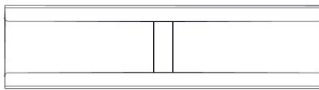

J1 SPLICE BRACKET - A4M01980
 (x1) 1 5/16"x5 3/16"x19 11/16" (33.2x131x500)



B01 BEAM - A4M01963
 (x1) 1 3/8"x5 1/4"x81 7/8" (36x134x2080)

DO NOT FULLY TIGHTEN BOLTS AT THIS STEP

1101 (x6)
 TORX PAN HEAD 1/4-20x3/4"

1053 (x6)
 STEEL WASHER 6x20

1054 (x6)
 SEALANT WASHER

J1 (x1)
 SPLICE BRACKET

NOTE: BEAM AND SPLICE MUST BE ORIENTED AS SHOWN BELOW. SLIDE J1 INTO B01 AND LINE UP THREE HOLES TOP AND BOTTOM.

B01 (x1)
 BEAM

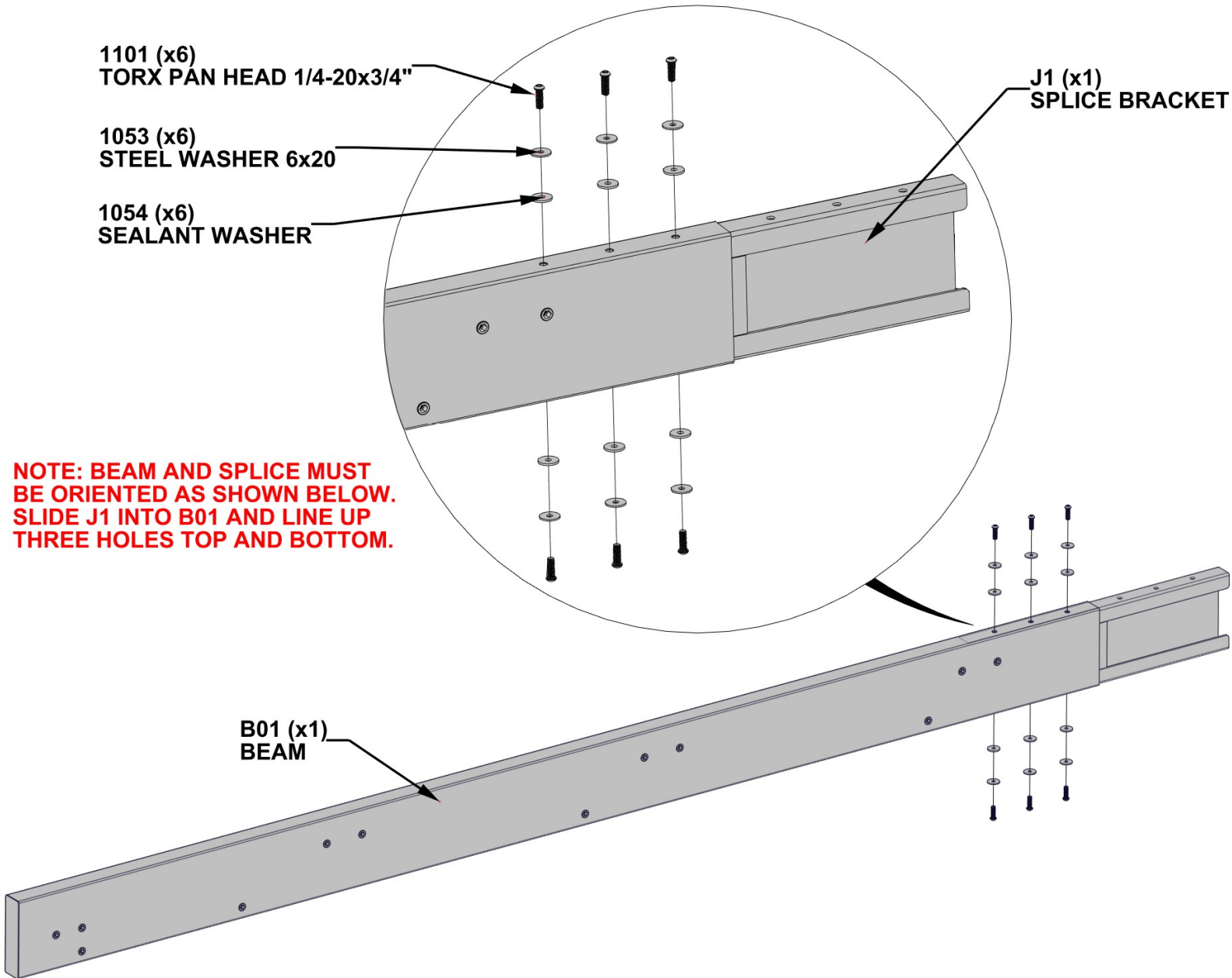

STEP 26 - BACK BEAM ASSEMBLY



B02 BEAM - A4M01965
 (x1) 1 3/8"x5 1/4"x81 7/8" (36x134x2079)

Qty	PART NUMBER	Description
6	H101101	TORX PAN HEAD 1/4-20x3/4"
6	H101053	STEEL WASHER 6x20
6	H101054	SEALANT WASHER

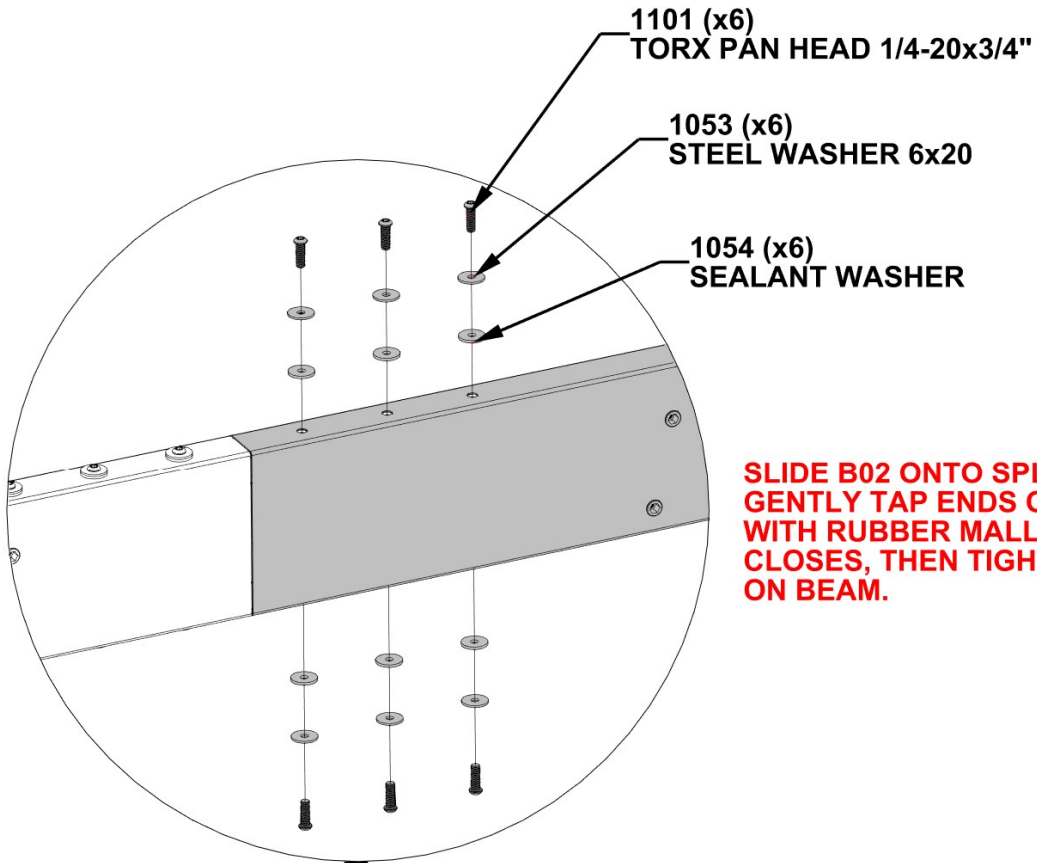

SLIDE B02 ONTO SPLICE BRACKET. GENTLY TAP ENDS OF ASSEMBLY WITH RUBBER Mallet UNTIL GAP CLOSES, THEN TIGHTEN ALL BOLTS ON BEAM.

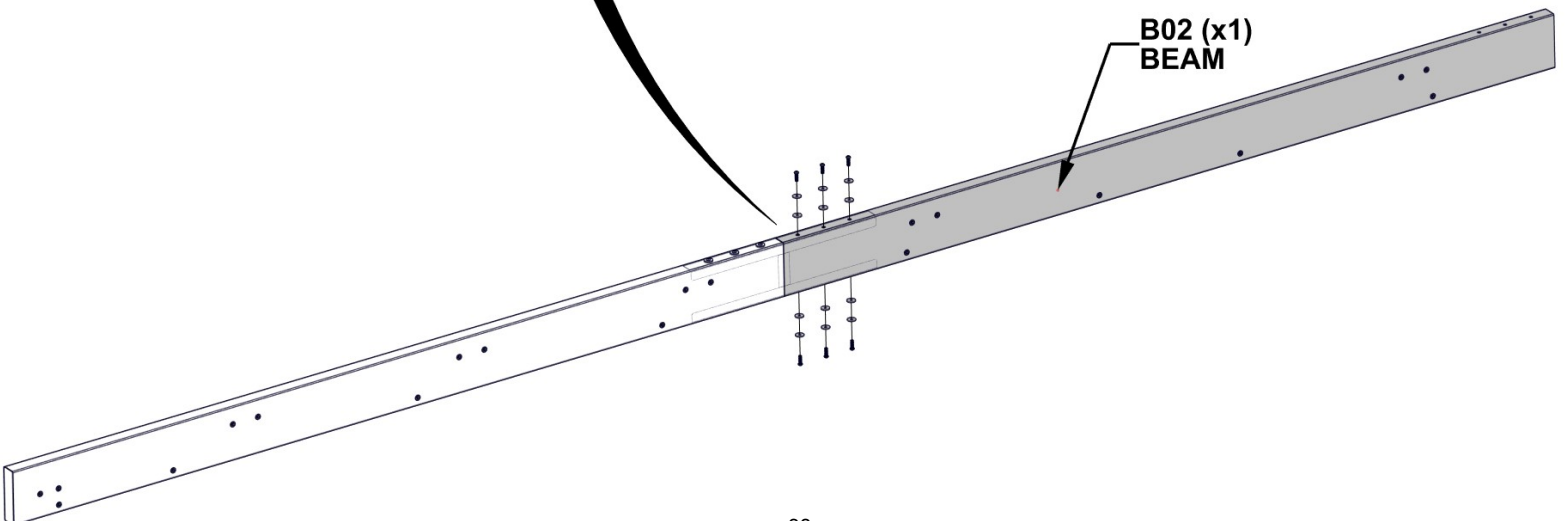

STEP 27 - BACK BEAM ASSEMBLY



J1 SPLICE BRACKET - A4M01980
(x1) 1 5/16"x5 3/16"x19 11/16" (33.2x131x500)

Qty	PART NUMBER	Description
6	H101053	STEEL WASHER 6x20
6	H101054	SEALANT WASHER
6	H101101	TORX PAN HEAD 1/4-20x3/4"

DO NOT FULLY TIGHTEN BOLTS AT THIS STEP

1101 (x6)
TORX PAN HEAD 1/4-20x3/4"

1053 (x6)
STEEL WASHER 6x20

1054 (x6)
SEALANT WASHER

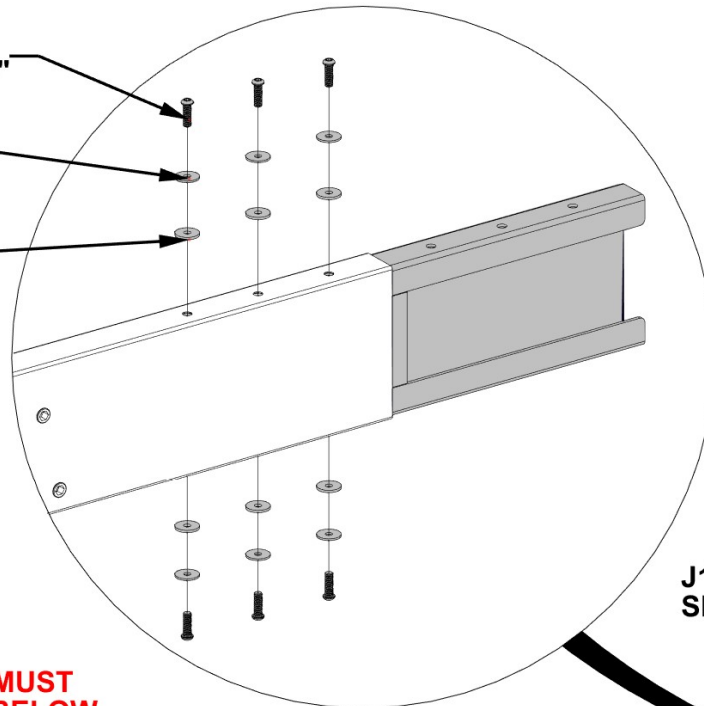

J1 (x1)
SPLICE BRACKET

NOTE: BEAM AND SPLICE MUST BE ORIENTED AS SHOWN BELOW. SLIDE J1 INTO B02 AND LINE UP THREE HOLES TOP AND BOTTOM.

B02
BEAM

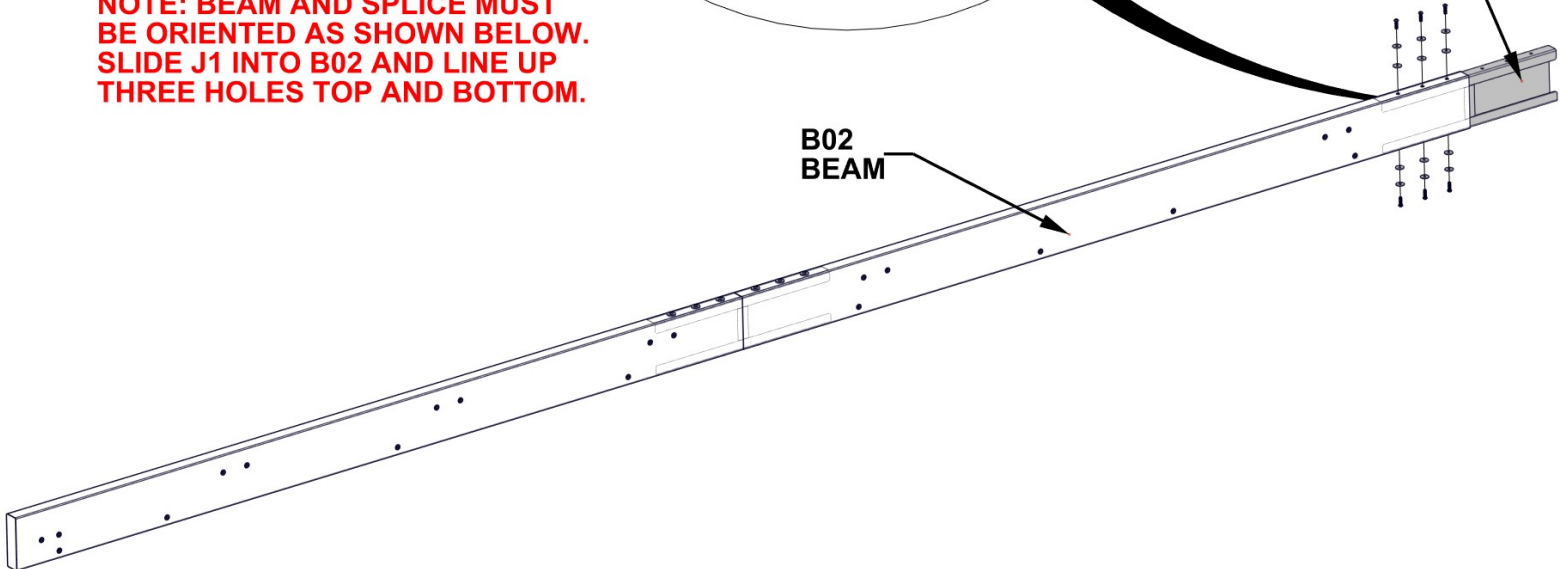

STEP 28 - BACK BEAM ASSEMBLY

Qty	PART NUMBER	Description
5	H101103	TORX SOCKET SCREW 1/4-20



BACK BEAM ASSEMBLY STEPS 23-24



BACK BEAM ASSEMBLY STEPS 25-27

ALIGN THRU HOLES IN BEAM ASSEMBLY STEPS 23-24 WITH ZERTS IN BEAM ASSEMBLY STEPS 25-27.

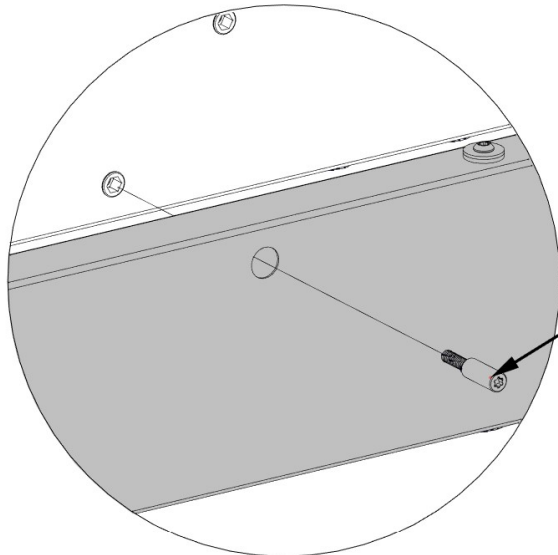

**1103 (x5)
TORX SOCKET SCREW 1/4-20**

**BACK BEAM ASSEMBLY
STEPS 25-27**

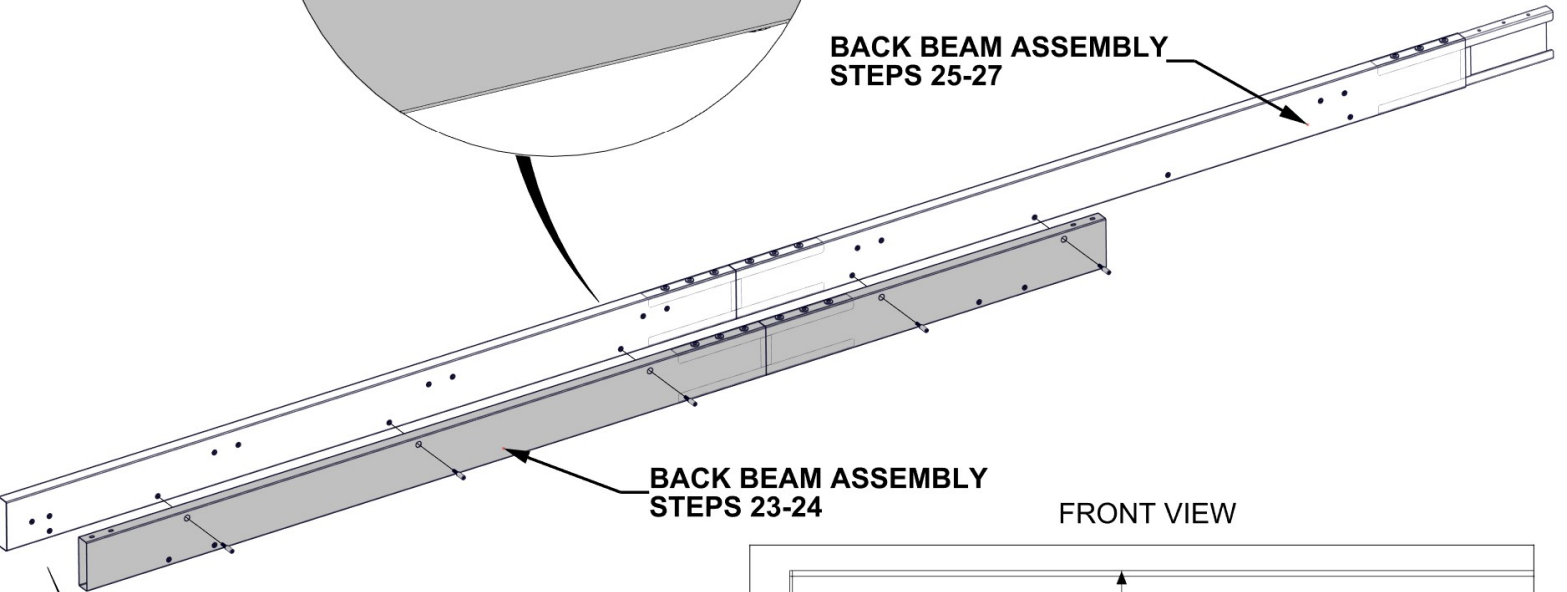

**BACK BEAM ASSEMBLY
STEPS 23-24**

FRONT VIEW

**DIMENSIONS ARE CRITICAL
TO THE BEAM ASSEMBLY**

**3 3/4" [95mm] DIMENSION IS
CRITICAL ALONG ENTIRE
LENGTH OF BEAM**

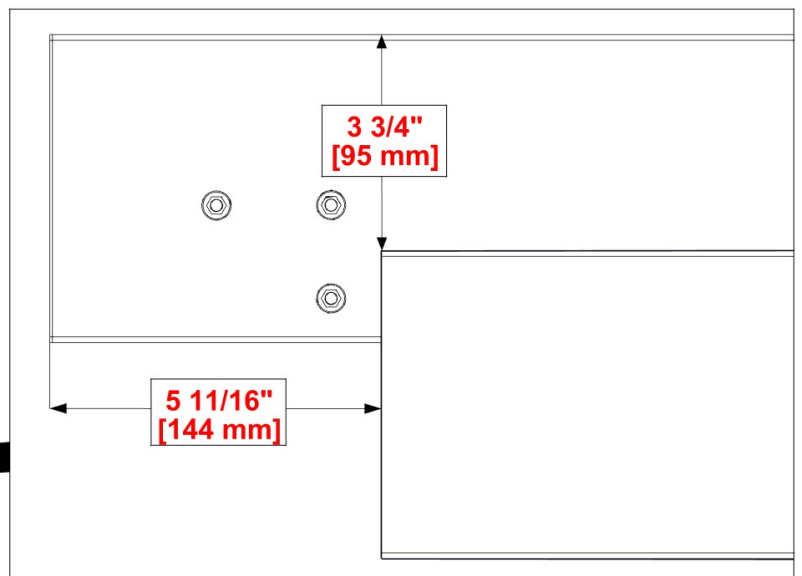

STEP 29 - BACK BEAM ASSEMBLY

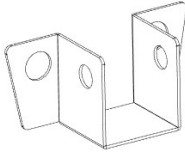

A4M01834 RAFTER BRACKET
(x5)

Qty	PART NUMBER	Description
10	H101054	SEALANT WASHER
10	H101053	STEEL WASHER 6x20
10	H101101	TORX PAN HEAD 1/4-20x3/4"

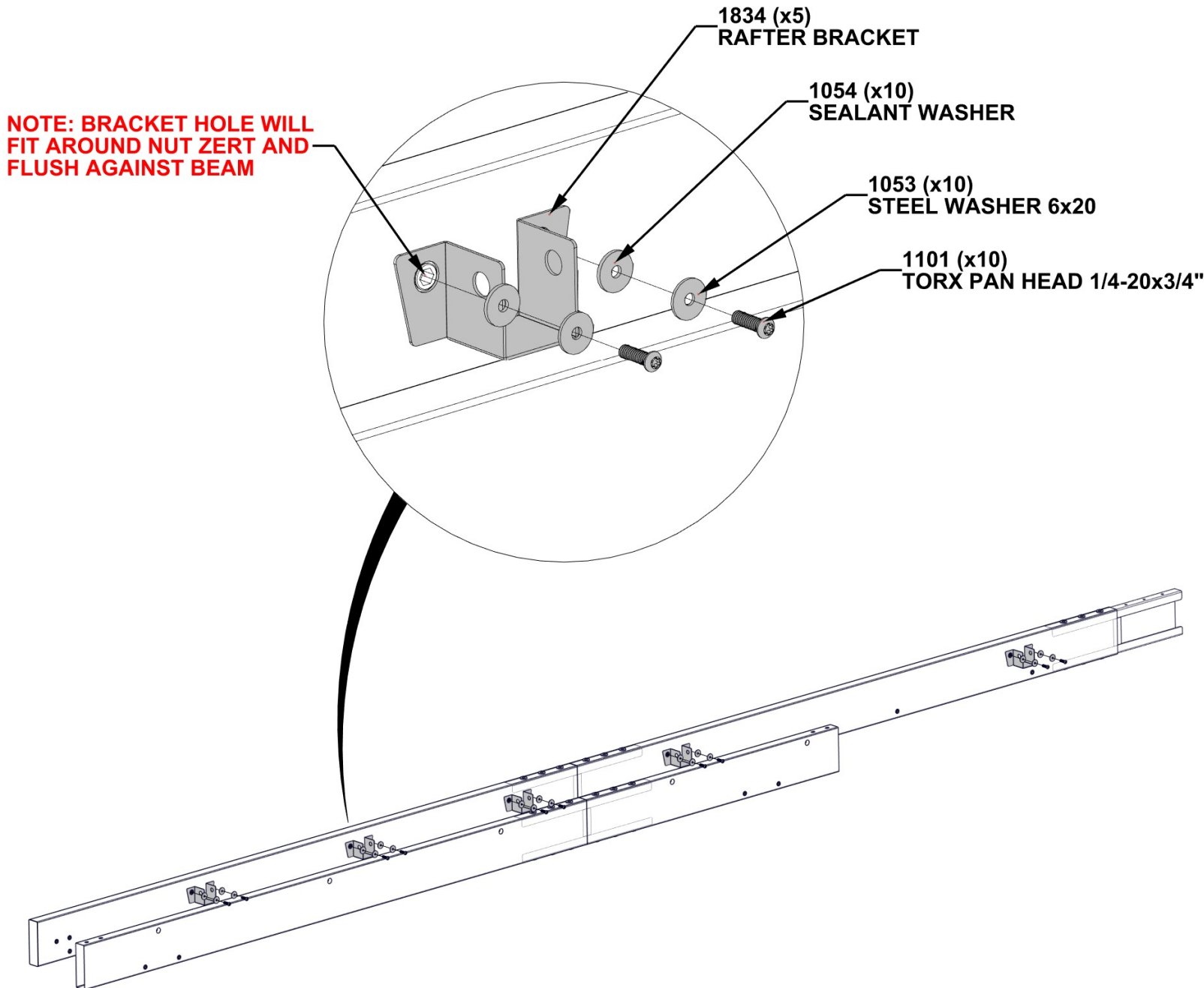

STEP 30A - GAZEBO ASSEMBLY

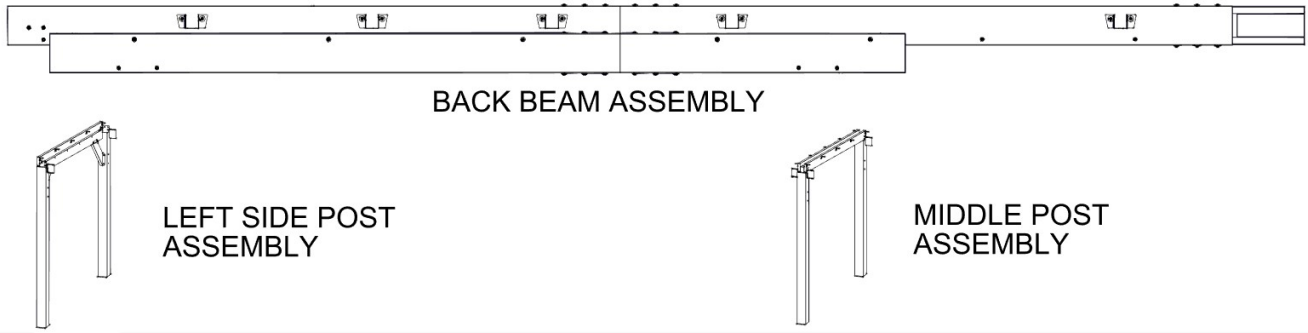

BEFORE BEGINNING, HAVE HARDWARE PREPARED FOR STEPS 30B AND 30C.

FOR THIS STEP IT IS HELPFUL TO HAVE THREE ADDITIONAL PEOPLE TO HELP STAND UP ASSEMBLIES AND TO SLIDE BACK BEAM ASSEMBLY INTO PLACE.

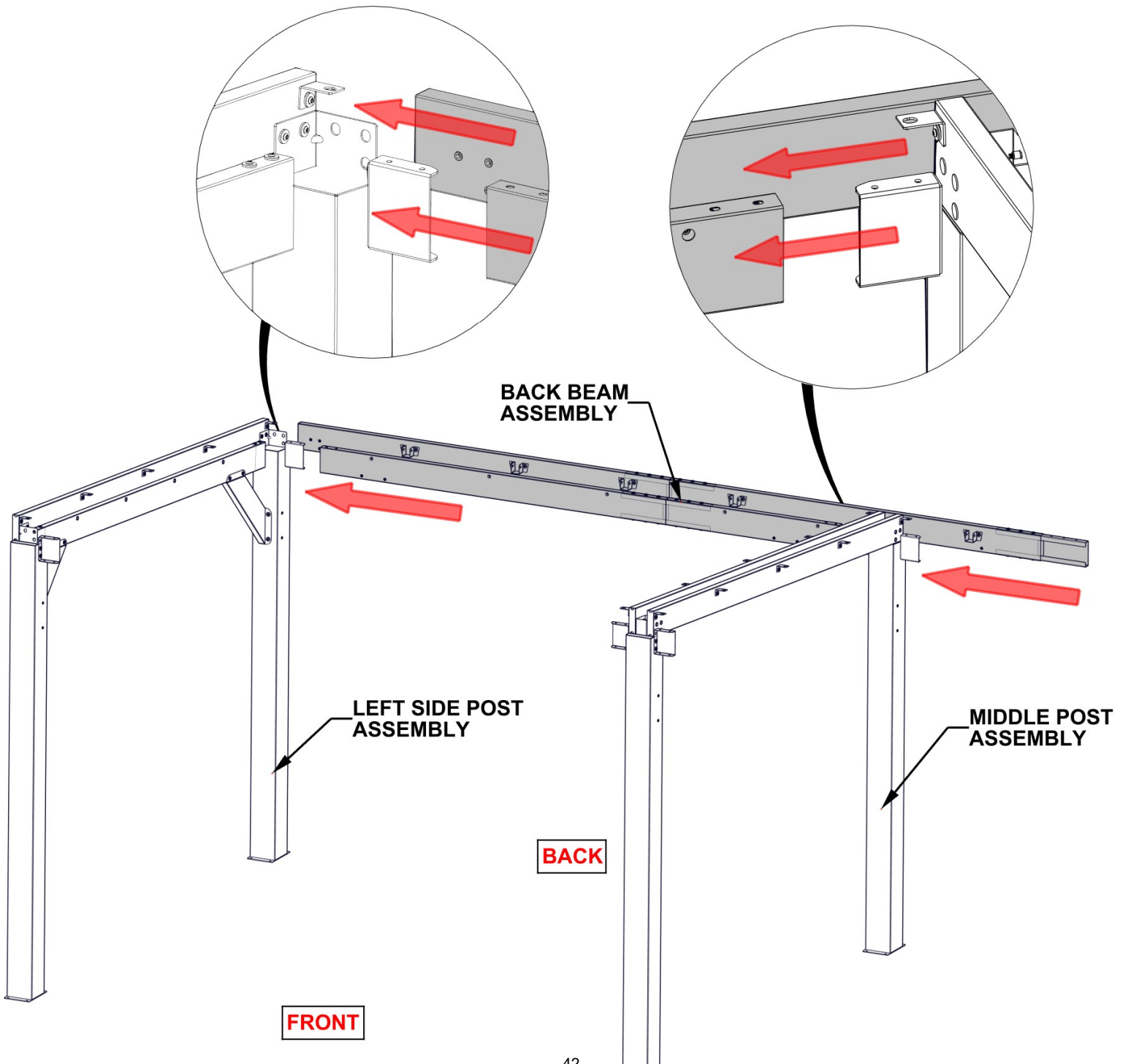

STEP 30B - GAZEBO ASSEMBLY

Qty	PART NUMBER	Description
3	H101054	SEALANT WASHER
3	H101101	TORX PAN HEAD 1/4-20x3/4"
3	H101053	STEEL WASHER 6x20

DO NOT FULLY TIGHTEN BOLTS AT THIS STEP

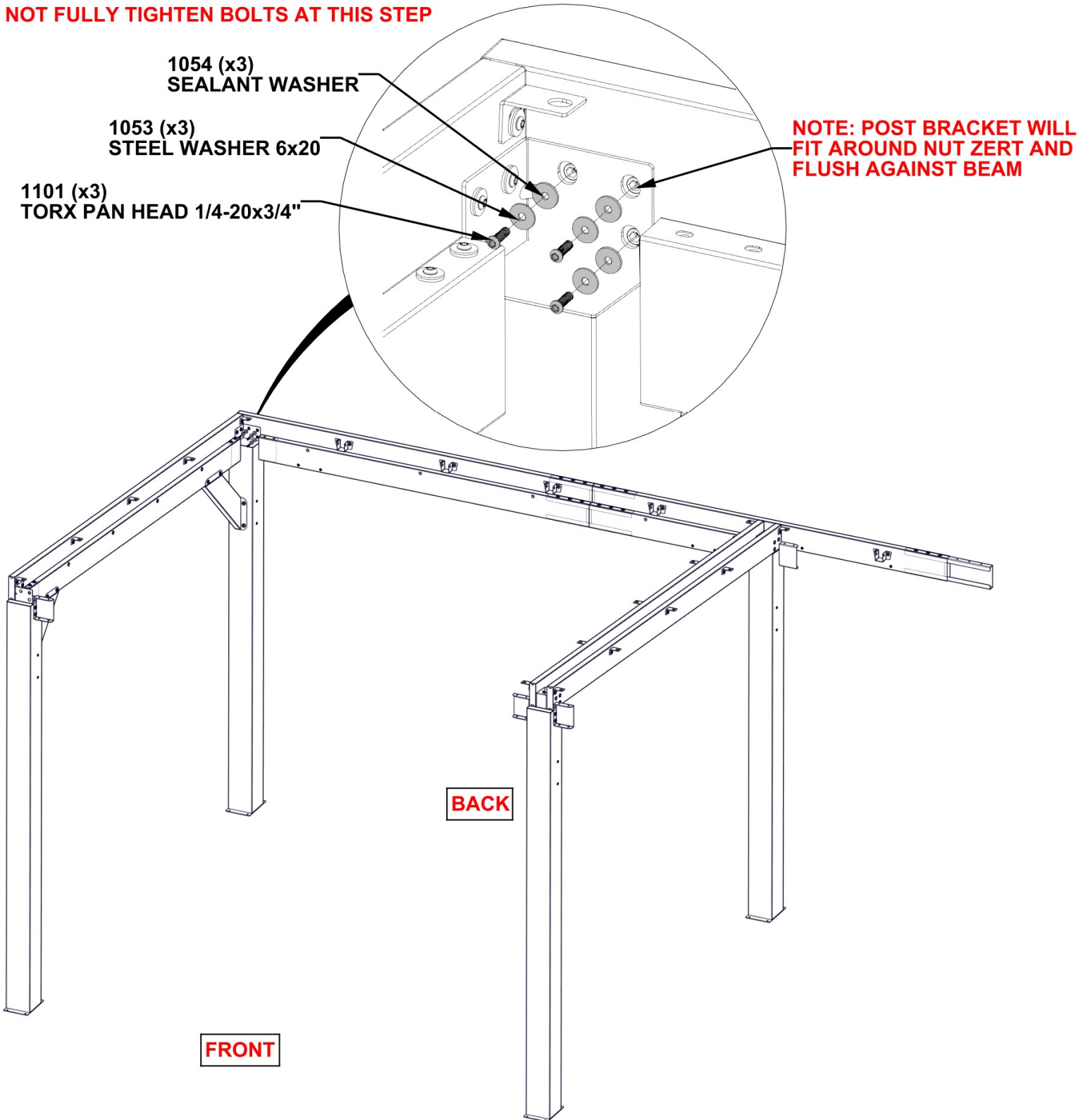

STEP 30C - GAZEBO ASSEMBLY

Qty	PART NUMBER	Description
8	H101101	TORX PAN HEAD 1/4-20x3/4"
8	H101053	STEEL WASHER 6x20
8	H101054	SEALANT WASHER

DO NOT FULLY TIGHTEN BOLTS AT THIS STEP

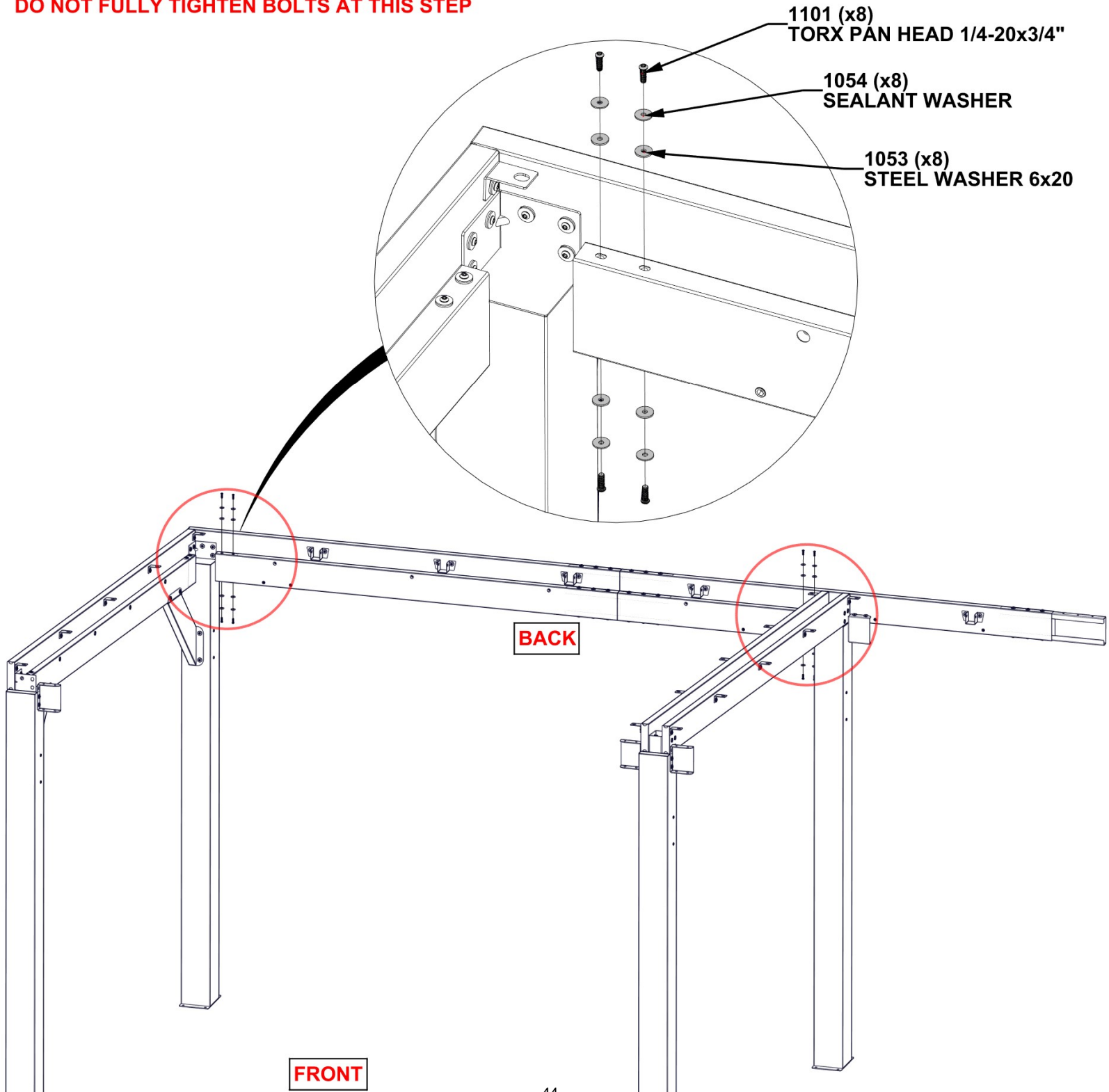

STEP 31A - GAZEBO ASSEMBLY

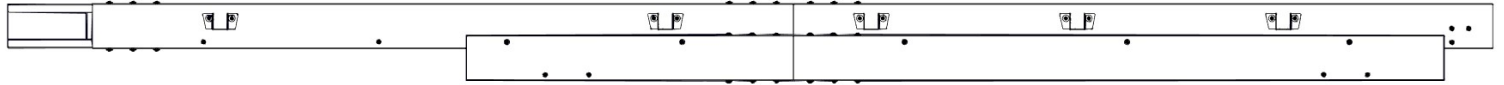

FRONT BEAM ASSEMBLY

BEFORE BEGINNING, HAVE HARDWARE PREPARED FOR STEPS 31B AND 31C.

FOR THIS STEP IT IS HELPFUL TO HAVE THREE ADDITIONAL PEOPLE TO HELP SLIDE FRONT BEAM ASSEMBLY INTO PLACE.

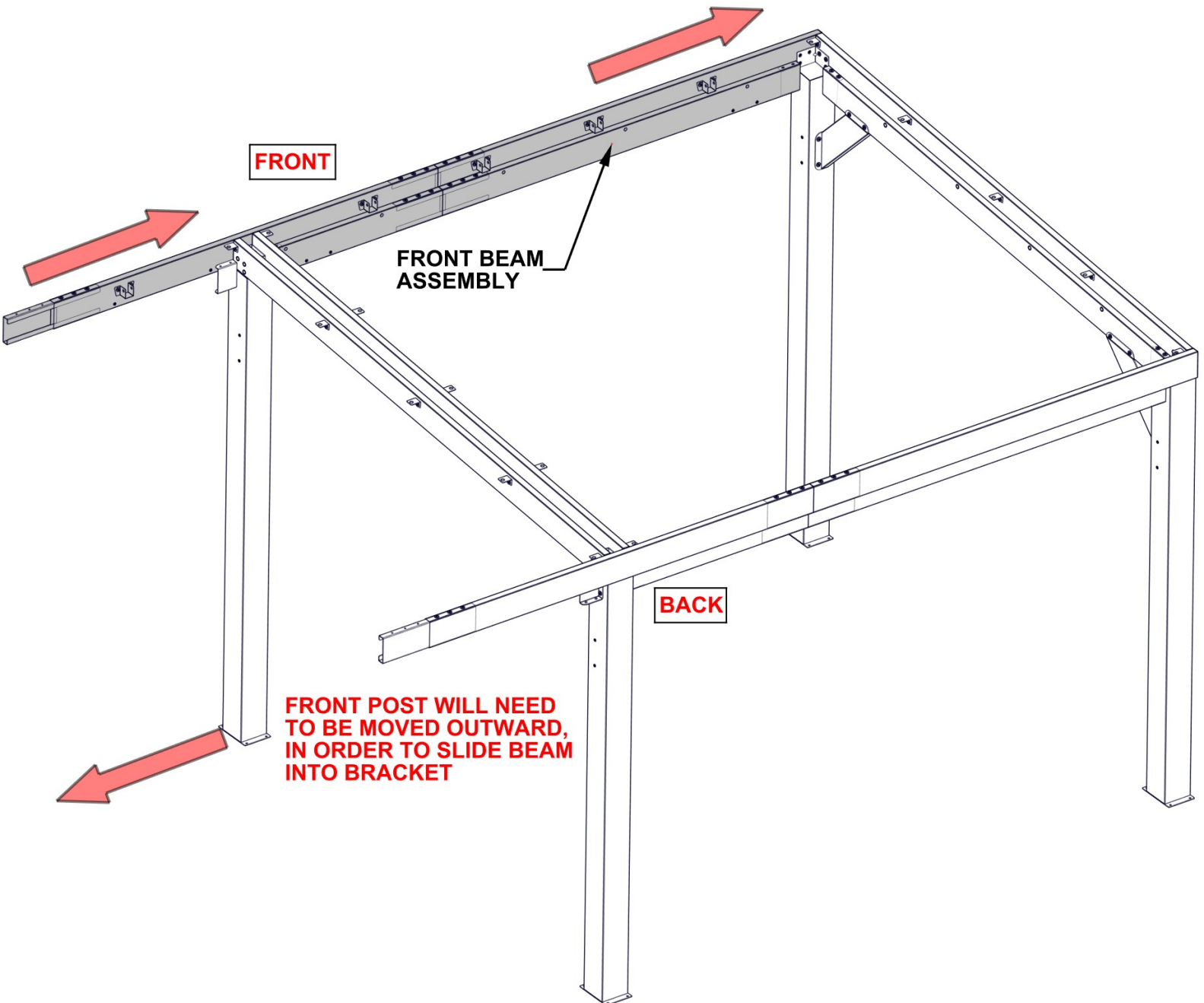

STEP 31B - GAZEBO ASSEMBLY

Qty	PART NUMBER	Description
3	H101053	STEEL WASHER 6x20
3	H101101	TORX PAN HEAD 1/4-20x3/4"
3	H101054	SEALANT WASHER

DO NOT FULLY TIGHTEN BOLTS AT THIS STEP

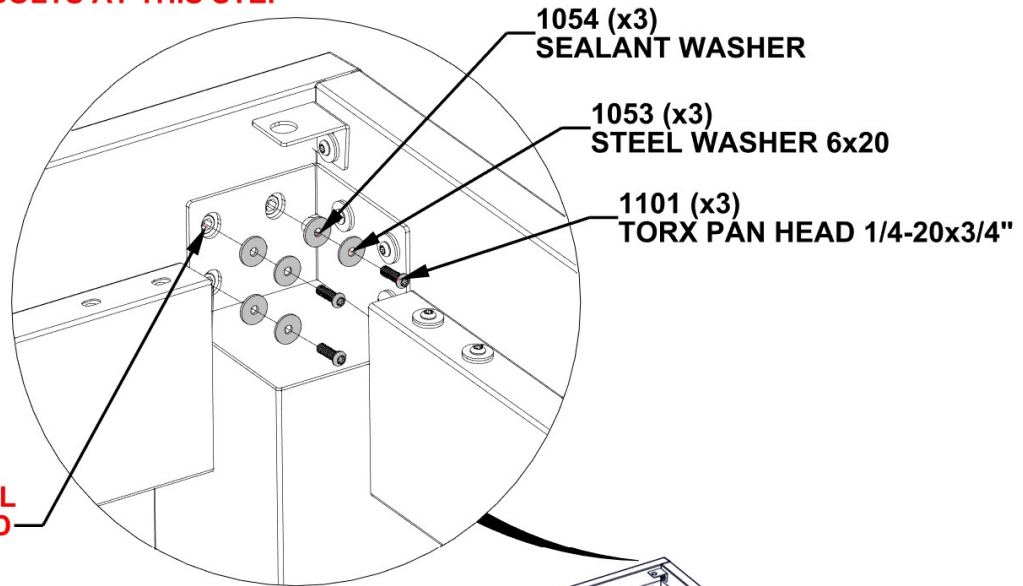

NOTE: POST BRACKET WILL FIT AROUND NUT ZERT AND FLUSH AGAINST BEAM

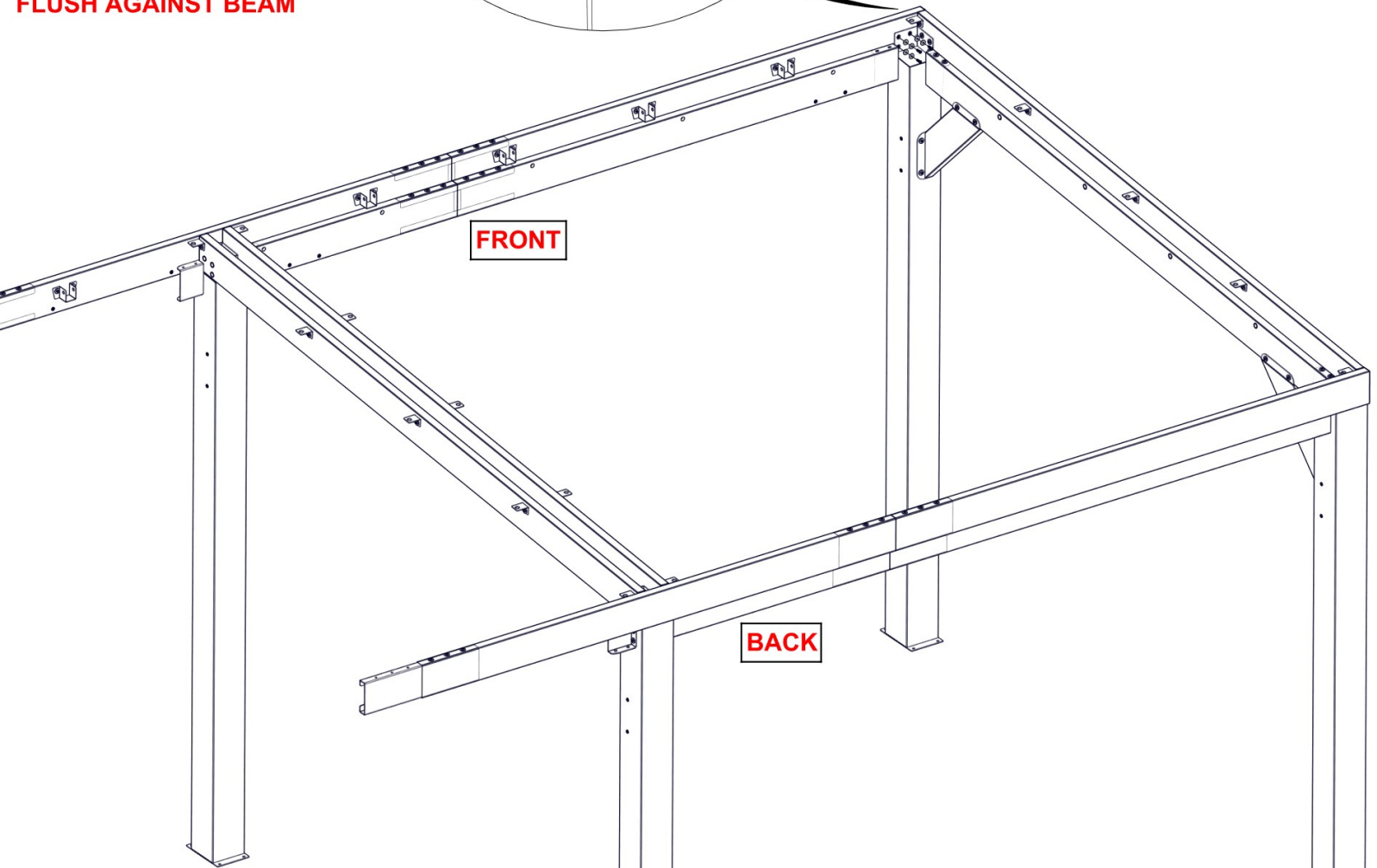

STEP 31C - GAZEBO ASSEMBLY

Qty	PART NUMBER	Description
8	H101054	SEALANT WASHER
8	H101101	TORX PAN HEAD 1/4-20x3/4"
8	H101053	STEEL WASHER 6x20

DO NOT FULLY TIGHTEN BOLTS AT THIS STEP

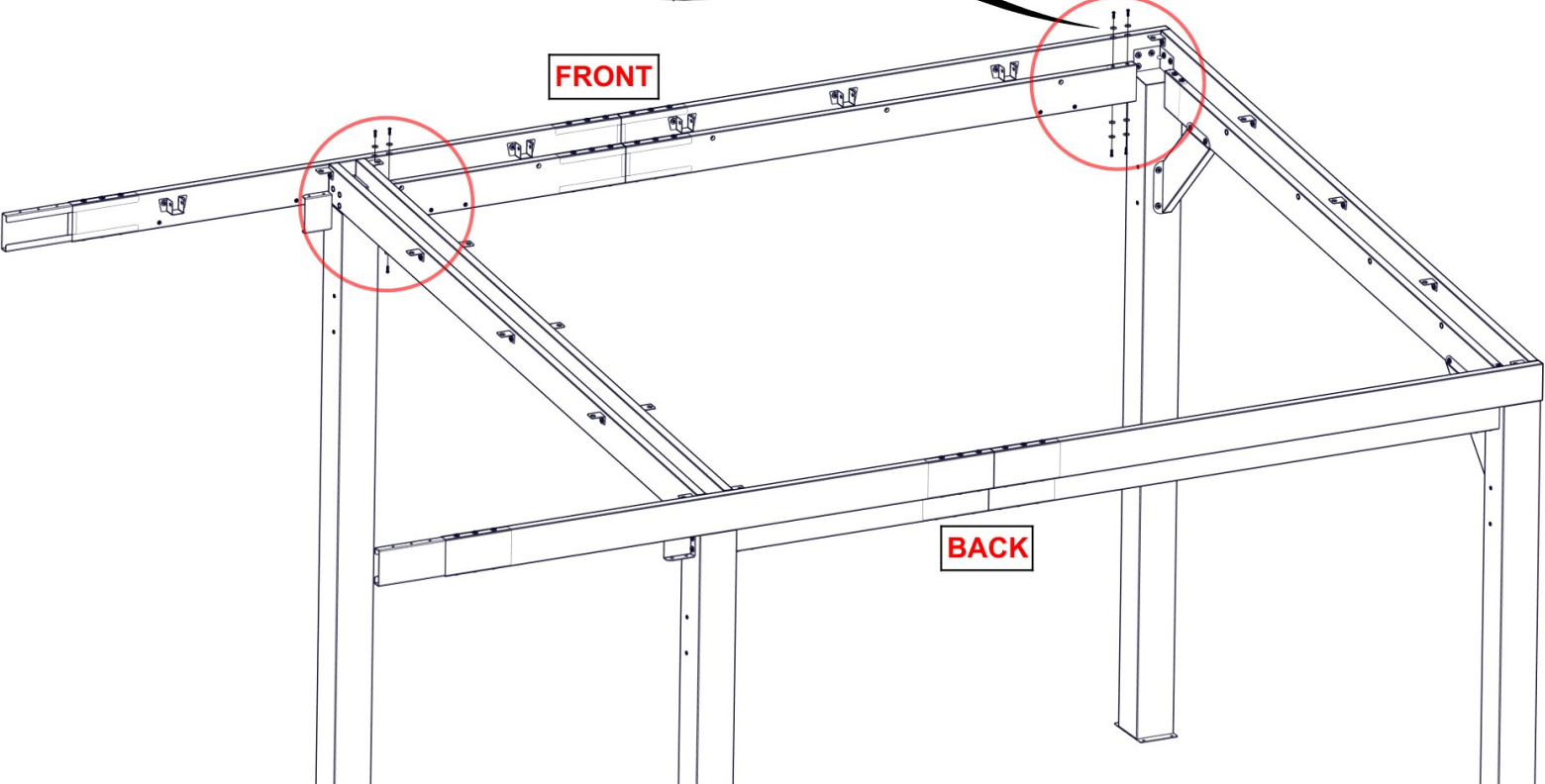
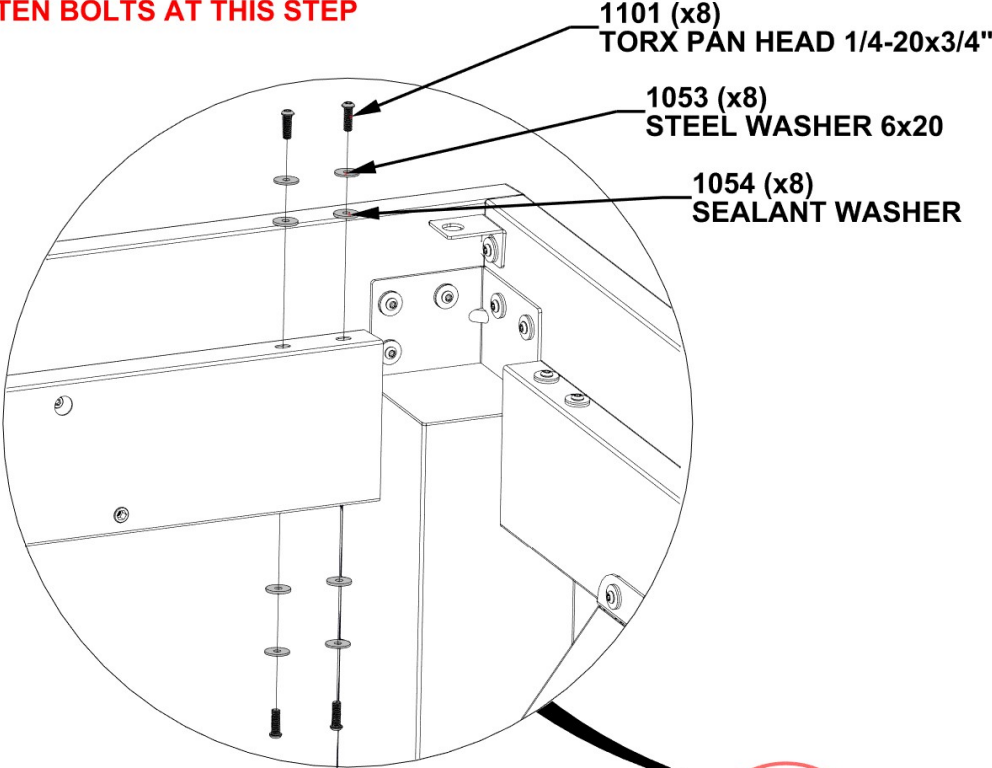

STEP 32 - GAZEBO ASSEMBLY



D01 CORBEL - A4M01817
(x1) 2 3/4"x5 13/16"x22 1/4" (70x147x565)



D02 CORBEL - A4M01818
(x1) 2 3/4"x5 13/16"x22 1/4" (70x147x565)

Qty	PART NUMBER	Description
8	H101054	SEALANT WASHER
8	H101101	TORX PAN HEAD 1/4-20x3/4"
8	H101053	STEEL WASHER 6x20

DO NOT FULLY TIGHTEN BOLTS AT THIS STEP

NOTE: CORBEL BRACKETS WILL FIT AROUND NUT ZERTS AND FLUSH AGAINST BEAM AND POST.

1054 (x8)
SEALANT WASHER

1053 (x8)
STEEL WASHER 6x20

1101 (x8)
TORX PAN HEAD 1/4-20x3/4"

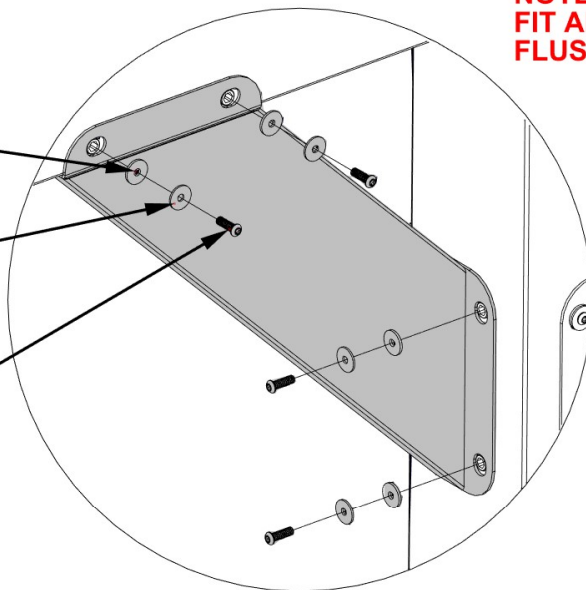

FRONT

D02 (x1)
CORBEL

D01 (x1)
CORBEL

BACK

STEP 33 - GAZEBO ASSEMBLY



D01 CORBEL - A4M01817
(x1) 2 3/4"x5 13/16"x22 1/4" (70x147x565)



D02 CORBEL - A4M01818
(x1) 2 3/4"x5 13/16"x22 1/4" (70x147x565)

Qty	PART NUMBER	Description
8	H101054	SEALANT WASHER
8	H101101	TORX PAN HEAD 1/4-20x3/4"
8	H101053	STEEL WASHER 6x20

DO NOT FULLY TIGHTEN BOLTS AT THIS STEP

NOTE: CORBEL BRACKETS WILL FIT AROUND NUT ZERTS AND FLUSH AGAINST BEAM AND POST.

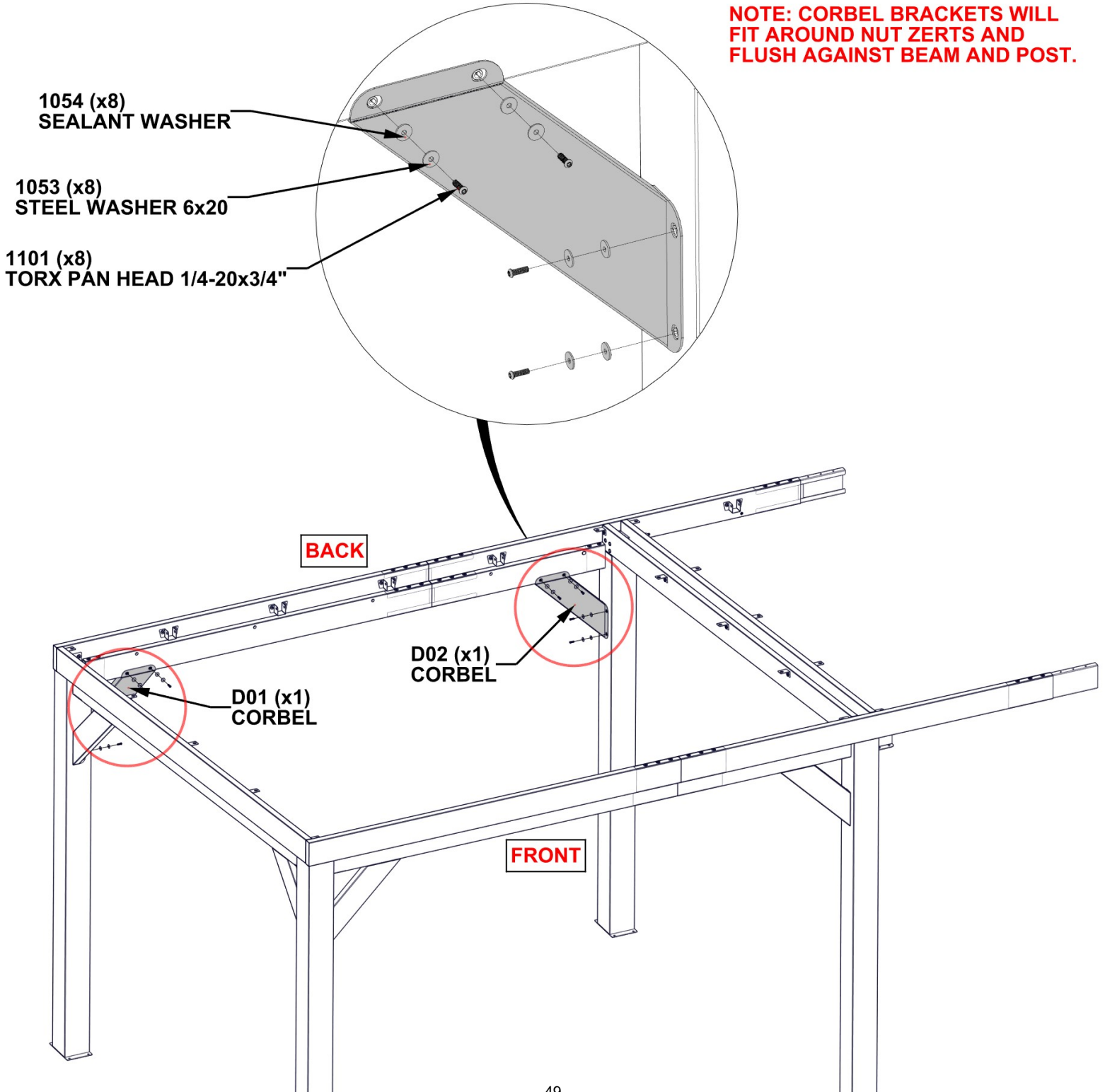

STEP 34 - GAZEBO ASSEMBLY

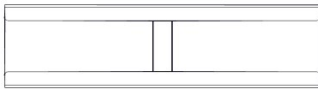

J1 SPLICE BRACKET - A4M01980
(x1) 1 5/16"x5 3/16"x19 11/16" (33.2x131x500)



B10 BEAM - A4M01968
(x1) 1 3/8"x5 1/4"x38 1/8" (36x134x969)

Qty	PART NUMBER	Description
2	H101103	TORX SOCKET SCREW 1/4-20
10	H101054	SEALANT WASHER
10	H101101	TORX PAN HEAD 1/4-20x3/4"
10	H101053	STEEL WASHER 6x20

DO NOT FULLY TIGHTEN BOLTS AT THIS STEP

NOTE: BEAM AND SPLICE MUST BE ORIENTED AS SHOWN BELOW. SLIDE J1 INTO B10 AND LINE UP THREE HOLES TOP AND BOTTOM.

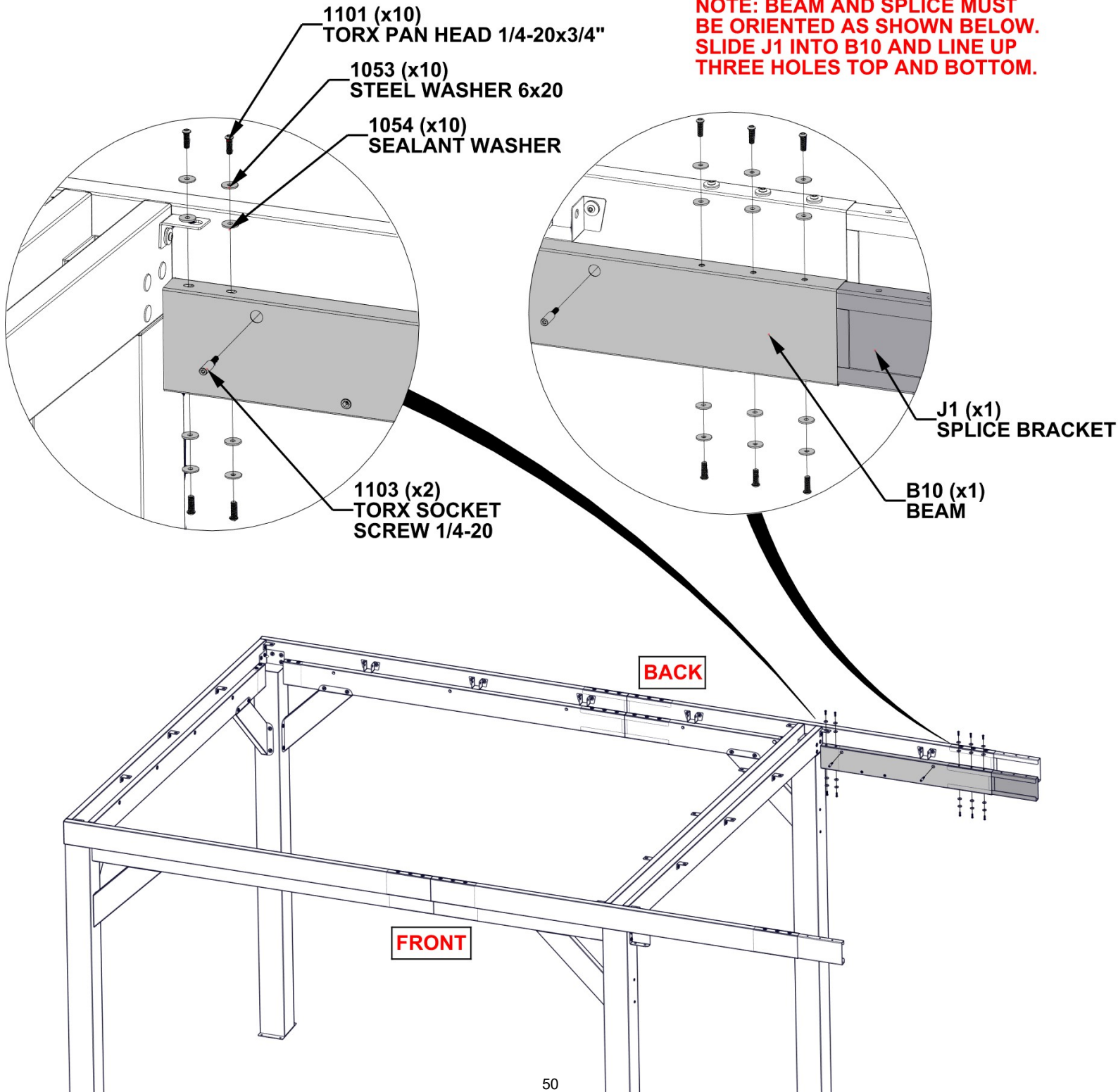

STEP 35 - GAZEBO ASSEMBLY



D01 CORBEL - A4M01817
(x1) 2 3/4"x5 13/16"x22 1/4" (70x147x565)

Qty	PART NUMBER	Description
4	H101054	SEALANT WASHER
4	H101101	TORX PAN HEAD 1/4-20x3/4"
4	H101053	STEEL WASHER 6x20

DO NOT FULLY TIGHTEN BOLTS AT THIS STEP

NOTE: CORBEL BRACKETS WILL FIT AROUND NUT ZERTS AND FLUSH AGAINST BEAM AND POST.

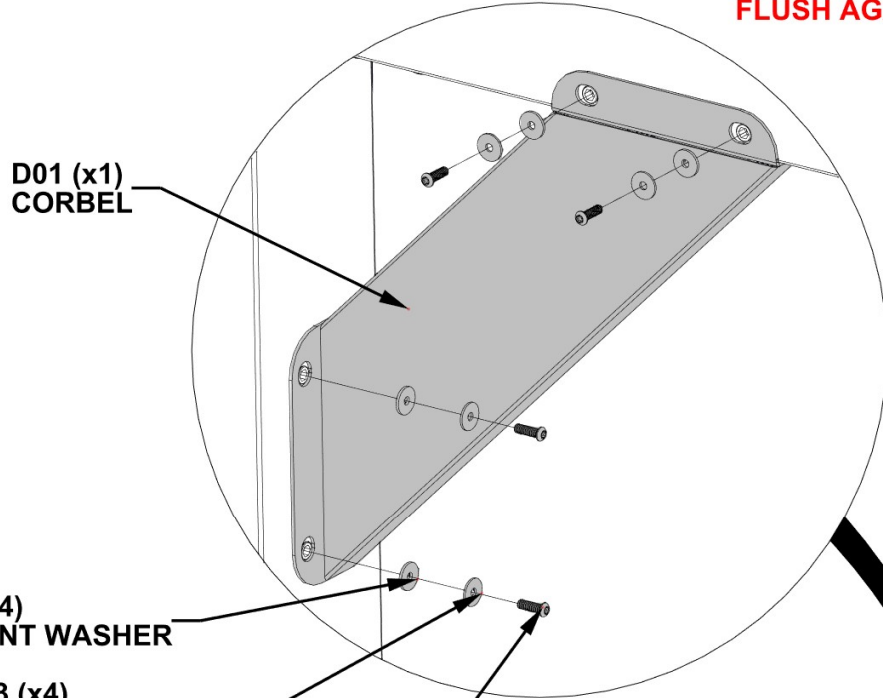

D01 (x1)
CORBEL

1054 (x4)
SEALANT WASHER

1053 (x4)
STEEL WASHER 6x20

1101 (x4)
TORX PAN HEAD 1/4-20x3/4"

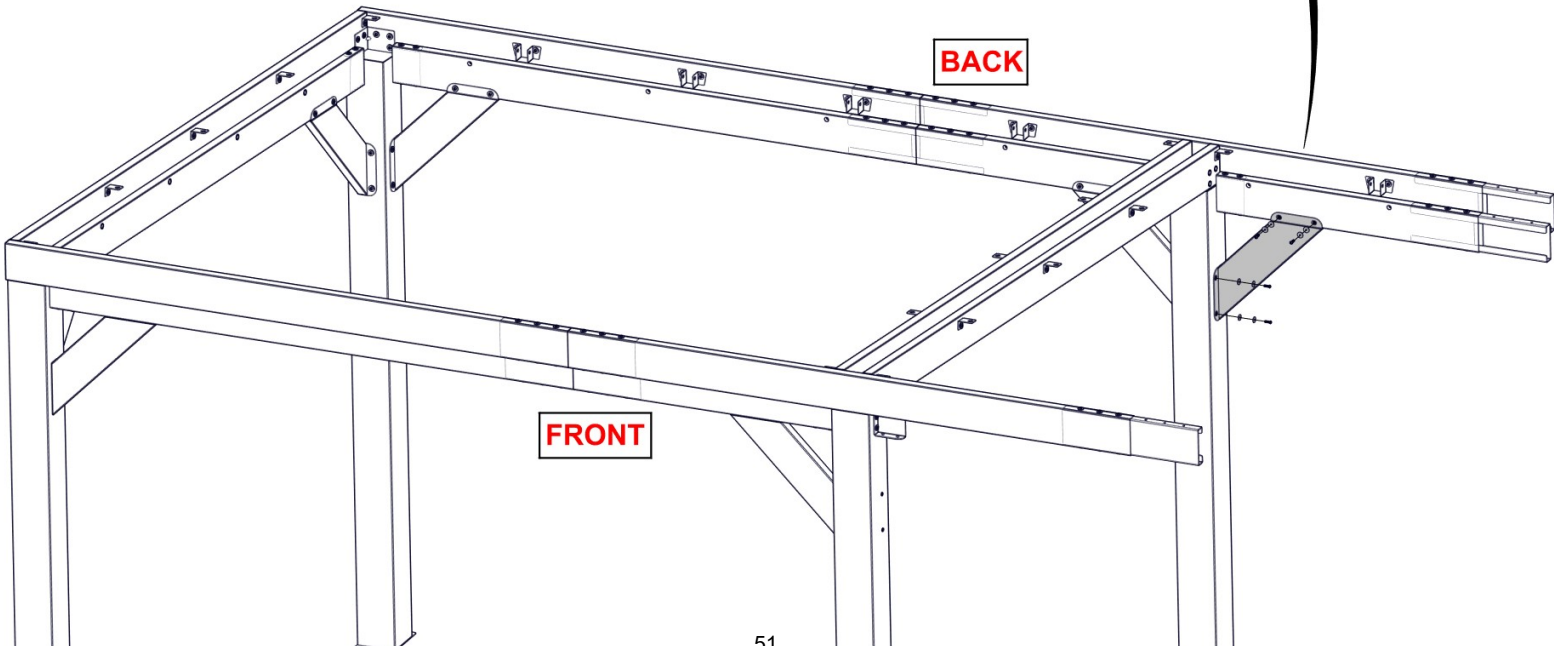

STEP 36 - GAZEBO ASSEMBLY

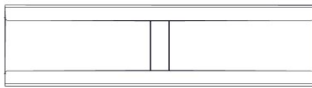

J1 SPLICE BRACKET - A4M01980
(x1) 1 5/16"x5 3/16"x19 11/16" (33.2x131x500)



B09 BEAM - A4M01969
(x1) 1 3/8"x5 1/4"x38 1/8" (36x134x969)

Qty	PART NUMBER	Description
2	H101103	TORX SOCKET SCREW 1/4-20
10	H101054	SEALANT WASHER
10	H101101	TORX PAN HEAD 1/4-20x3/4"
10	H101053	STEEL WASHER 6x20

DO NOT FULLY TIGHTEN BOLTS AT THIS STEP

NOTE: BEAM AND SPLICE MUST BE ORIENTED AS SHOWN BELOW. SLIDE J1 INTO B09 AND LINE UP THREE HOLES TOP AND BOTTOM.

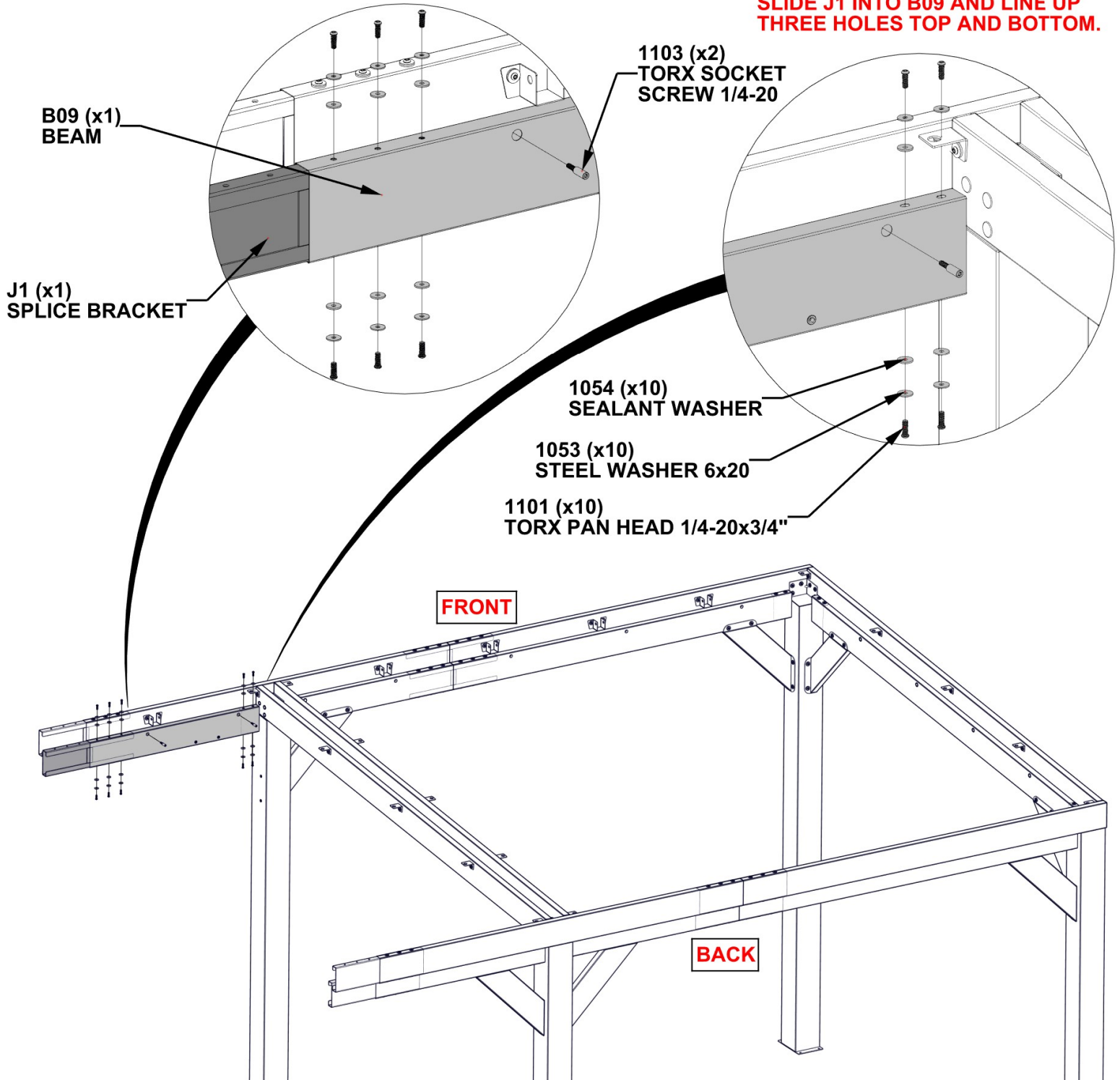

STEP 37 - GAZEBO ASSEMBLY



D02 CORBEL - A4M01818
(x1) 2 3/4"x5 13/16"x22 1/4" (70x147x565)

Qty	PART NUMBER	Description
4	H101054	SEALANT WASHER
4	H101101	TORX PAN HEAD 1/4-20x3/4"
4	H101053	STEEL WASHER 6x20

DO NOT FULLY TIGHTEN BOLTS AT THIS STEP

NOTE: CORBEL BRACKETS WILL FIT AROUND NUT ZERTS AND FLUSH AGAINST BEAM AND POST.

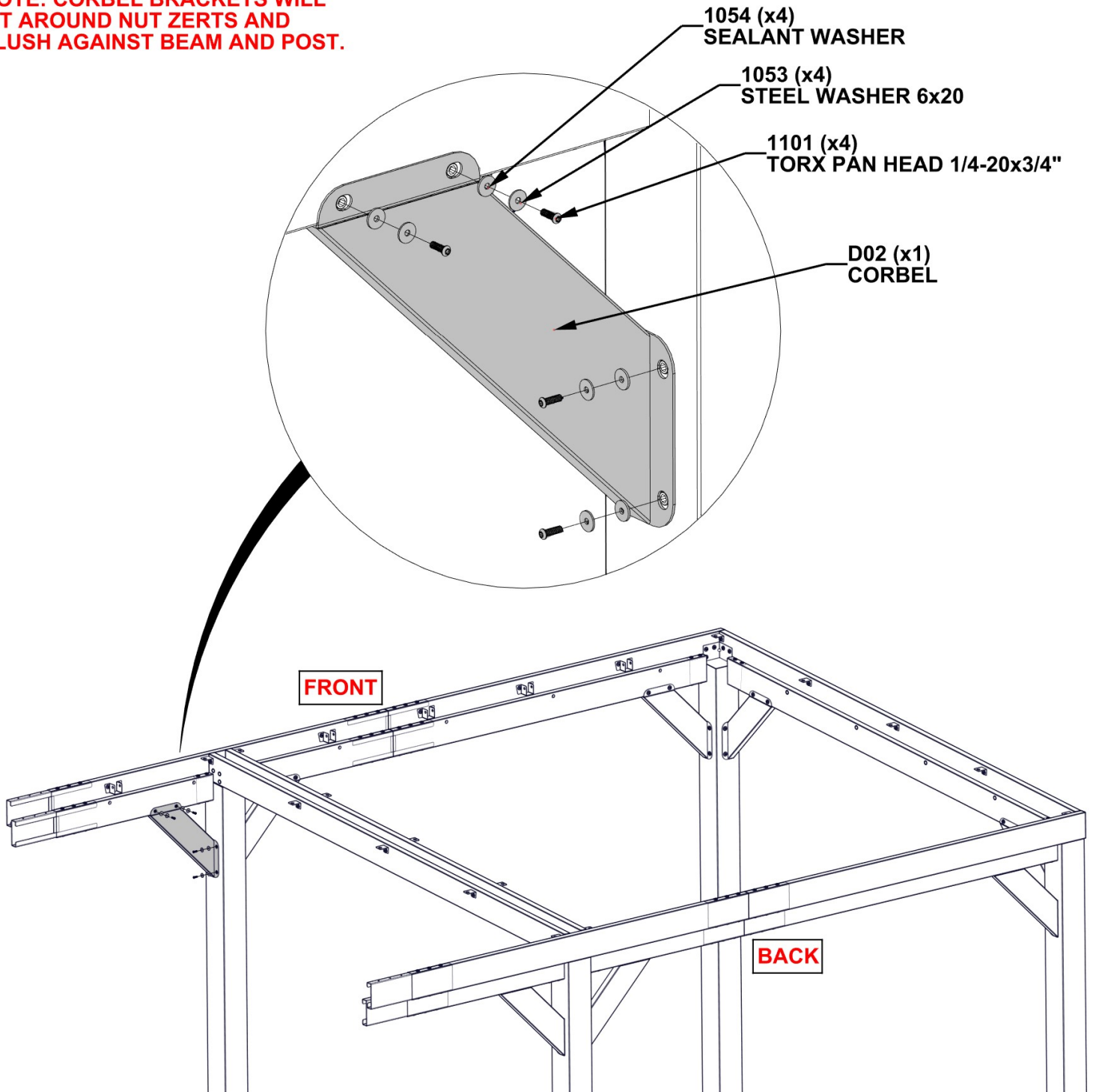

STEP 38 - BEAM ASSEMBLY

Qty	PART NUMBER	Description
4	H101103	TORX SOCKET SCREW 1/4-20



B06 SIDE BEAM - A4M01825
(x1) 1 3/8"x5 1/4"x103 1/8" (36x134x2618)

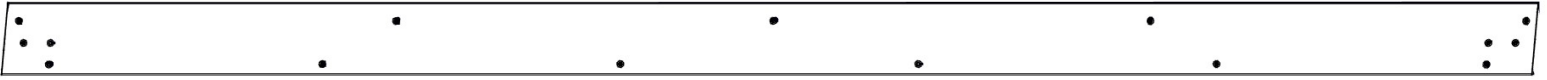

B05 SIDE BEAM - A4M01819
(x1) 1 3/8"x5 1/4"x111 3/4" (36x134x2839)

FOR EASE OF ASSEMBLY, WE RECOMMEND USING SAW HORSES FOR STEPS 38-48.

1103 (x4)
TORX SOCKET SCREW 1/4-20

**ALIGN THRU HOLES IN
B06 SIDE BEAM WITH
ZERTS IN B05 SIDE BEAM**

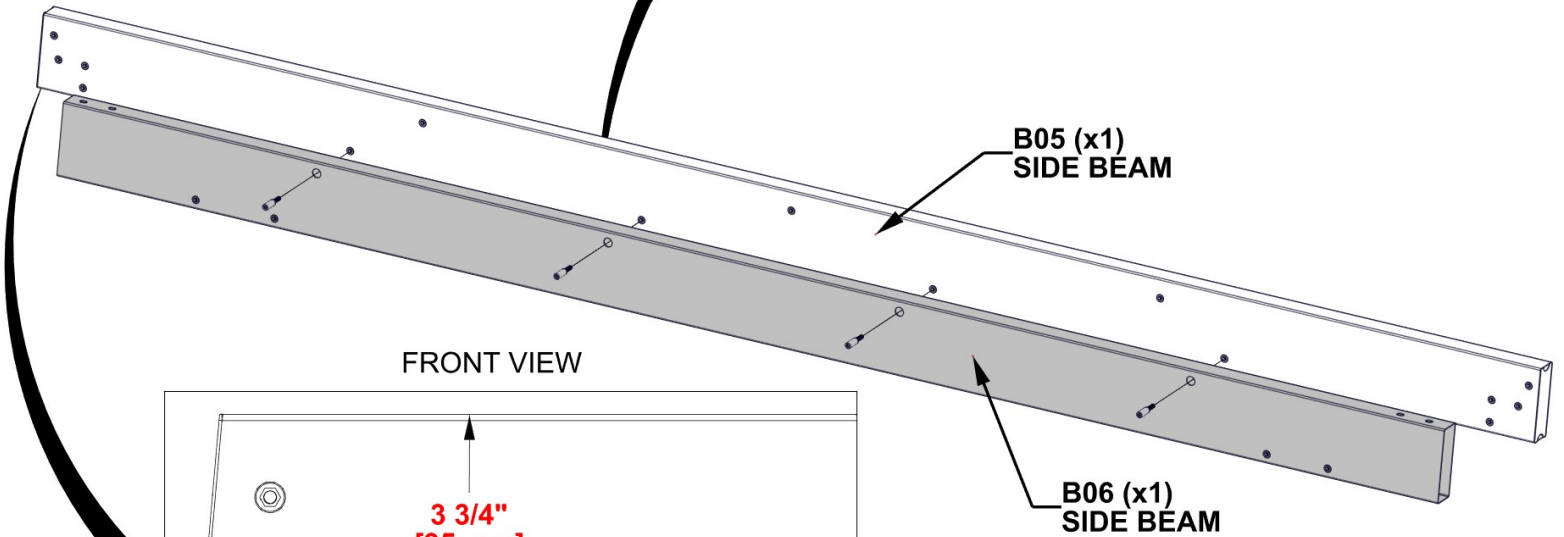
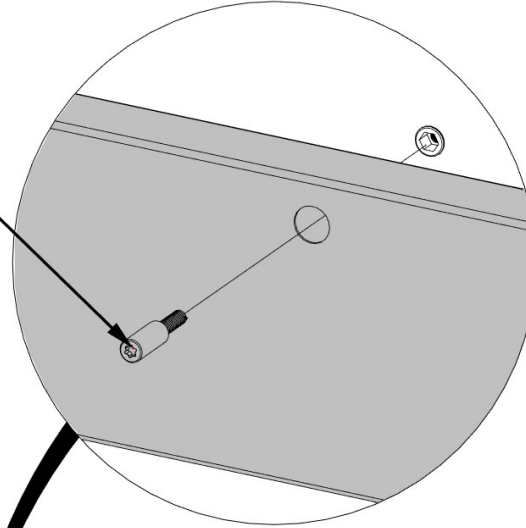

FRONT VIEW

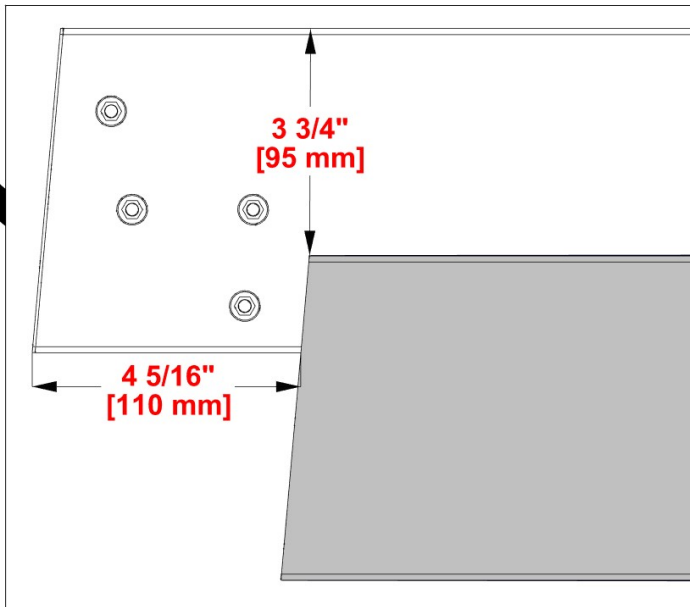

**DIMENSIONS ARE THE SAME
AT BOTH ENDS AND CRITICAL
TO THE BEAM ASSEMBLY**

STEP 39 - BEAM ASSEMBLY

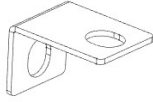

A4M01844 PURLIN BRACKET
(x5)

Qty	PART NUMBER	Description
5	H101054	SEALANT WASHER
5	H101101	TORX PAN HEAD 1/4-20x3/4"
5	H101053	STEEL WASHER 6x20

DO NOT FULLY TIGHTEN BOLTS AT THIS STEP

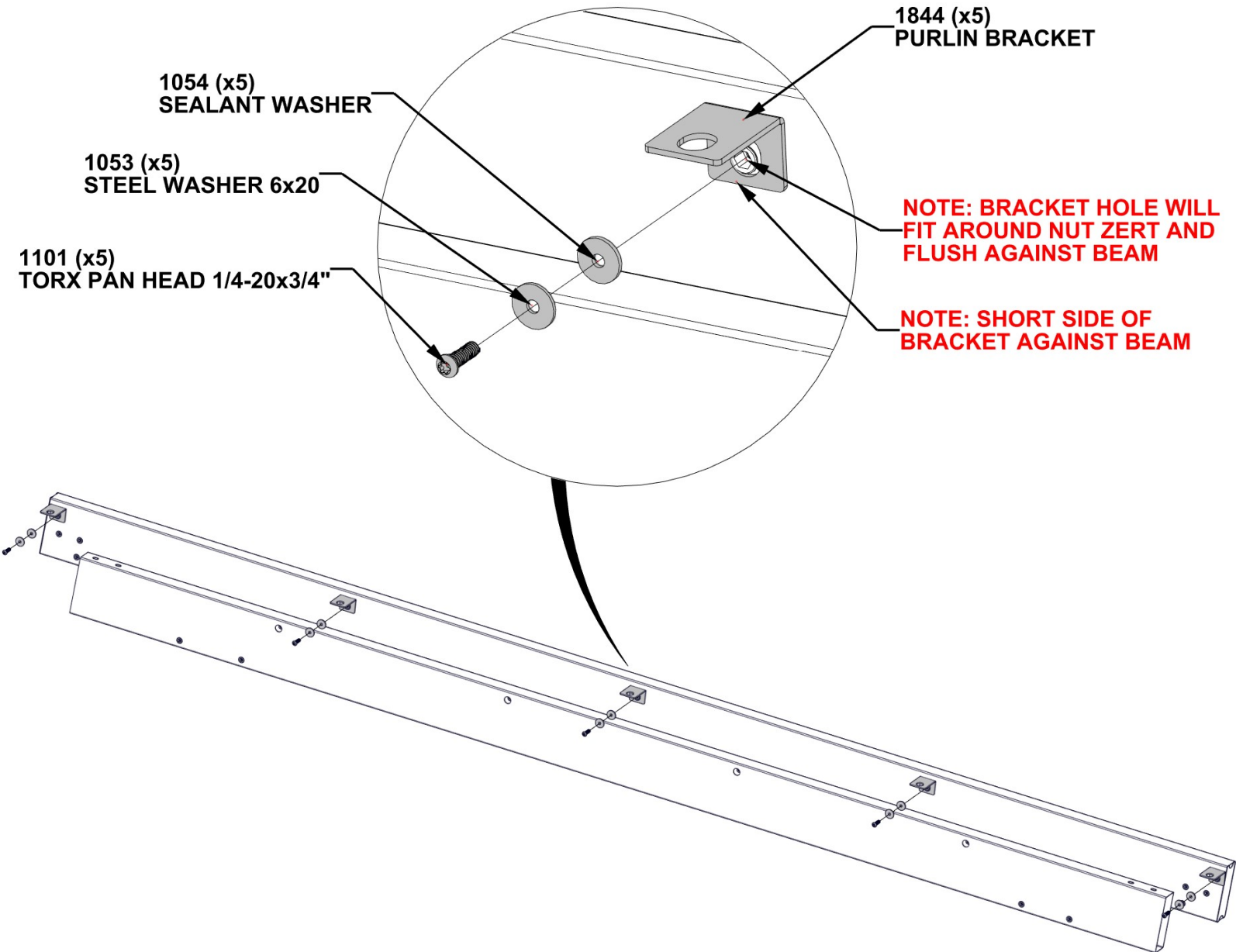

STEP 40 - POST ASSEMBLY

Qty	PART NUMBER	Description
2	H101053	STEEL WASHER 6x20
2	H101054	SEALANT WASHER
2	H101101	TORX PAN HEAD 1/4-20x3/4"

P03 BACK POST - A4M01810
(x1) 5 1/2"x8"x87 5/8" (140x202x2225)

A4M01820 ANGLED BEAM BRACKET
(x1)

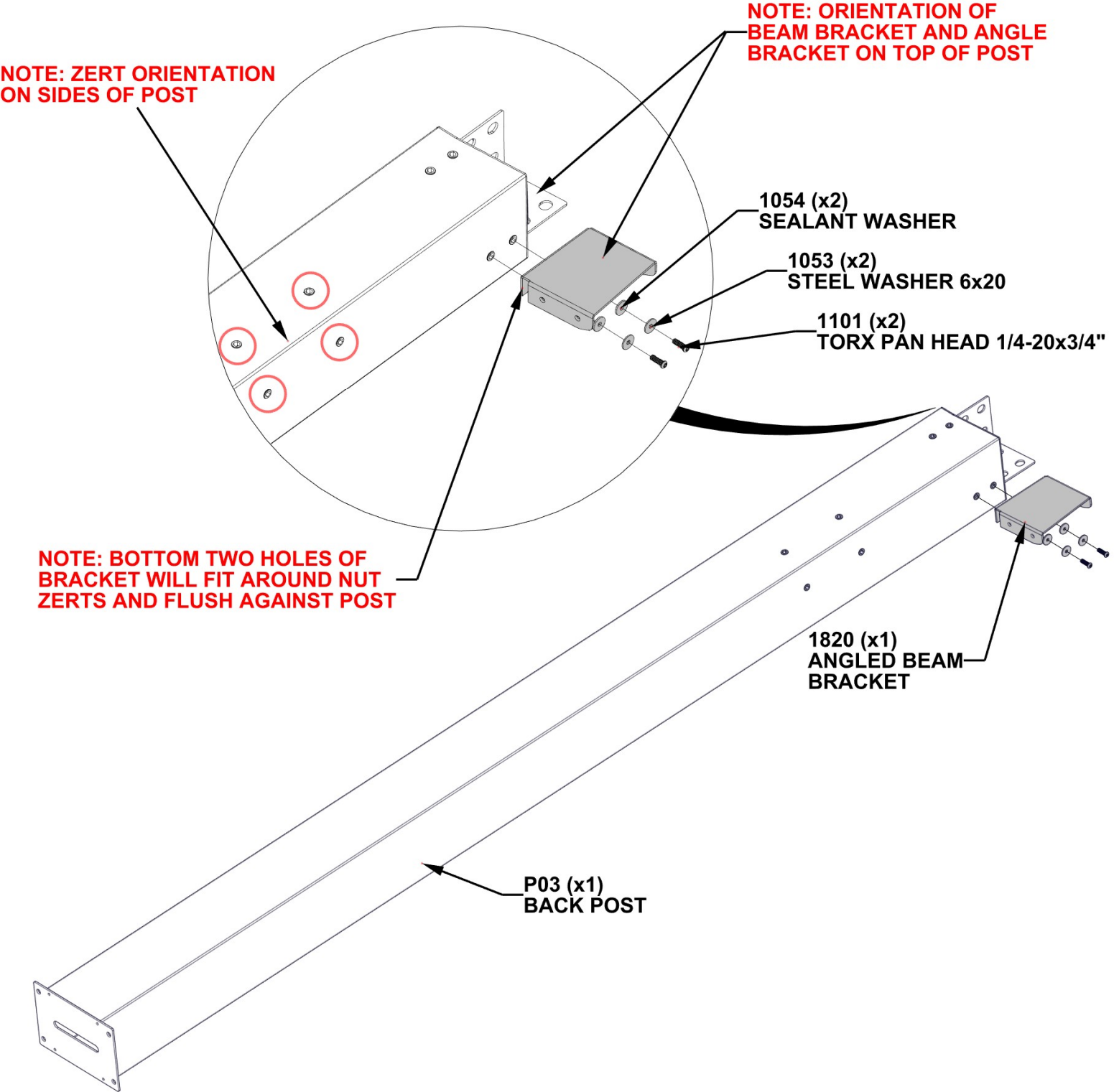

STEP 41 - POST ASSEMBLY

Qty	PART NUMBER	Description
2	H101054	SEALANT WASHER
2	H101101	TORX PAN HEAD 1/4-20x3/4"
2	H101053	STEEL WASHER 6x20



P01 FRONT POST - A4M01808
(x1) 5 1/2"x8"x97" (140x202x2462)

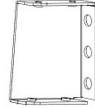

A4M01820 ANGLED BEAM BRACKET
(x1)

NOTE: ORIENTATION OF BEAM BRACKET AND ANGLE BRACKET ON TOP OF POST

NOTE: ZERT ORIENTATION ON SIDES OF POST

1054 (x2)
SEALANT WASHER

1053 (x2)
STEEL WASHER 6x20

1101 (x2)
TORX PAN HEAD 1/4-20x3/4"

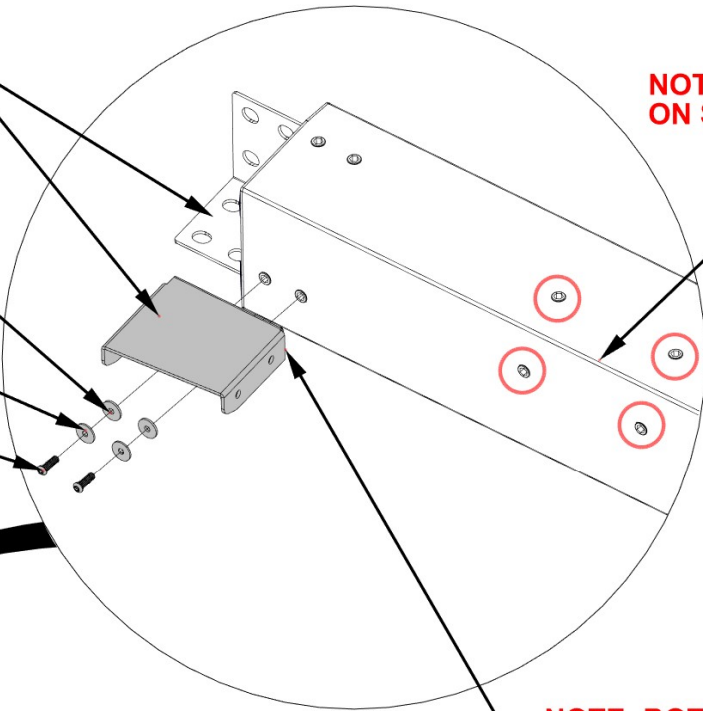

NOTE: BOTTOM TWO HOLES OF BRACKET WILL FIT AROUND NUT ZERTS AND FLUSH AGAINST POST

1820 (x1)
ANGLED BEAM BRACKET

P01 (x1)
FRONT POST

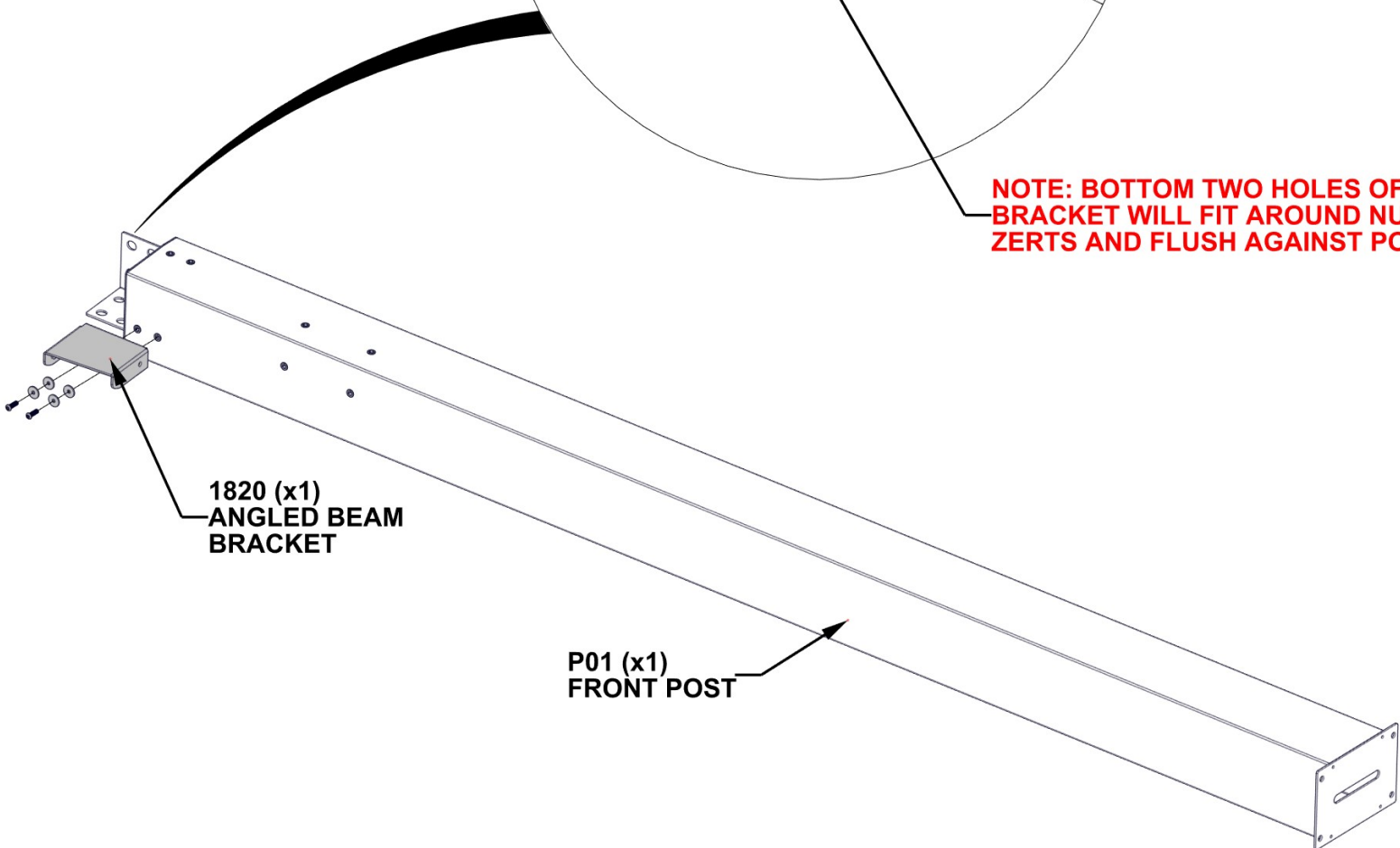

STEP 42A - RIGHT SIDE POST ASSEMBLY



BEAM ASSEMBLY FROM STEPS 38-39

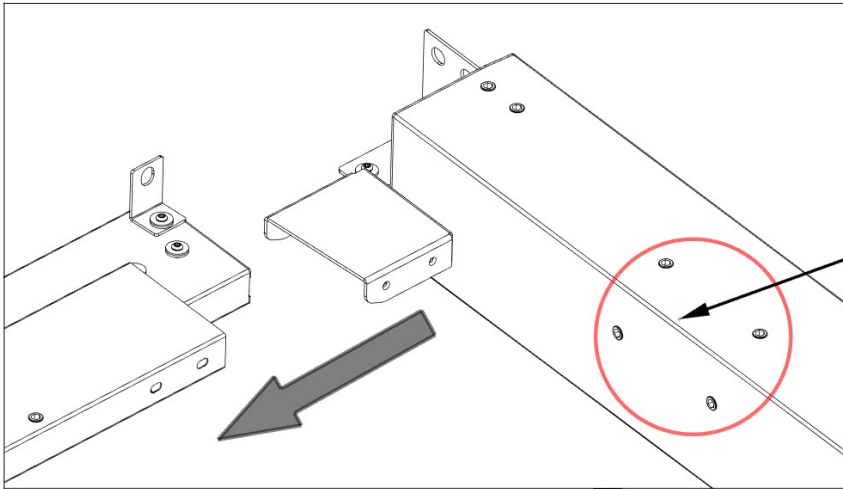

SLIDE EACH POST ASSEMBLY INTO THE BEAM ASSEMBLY FROM STEP 38-39

NOTE: POST ORIENTATION. ZERTS WILL FACE UP AND TOWARD EACH OTHER ON POST.

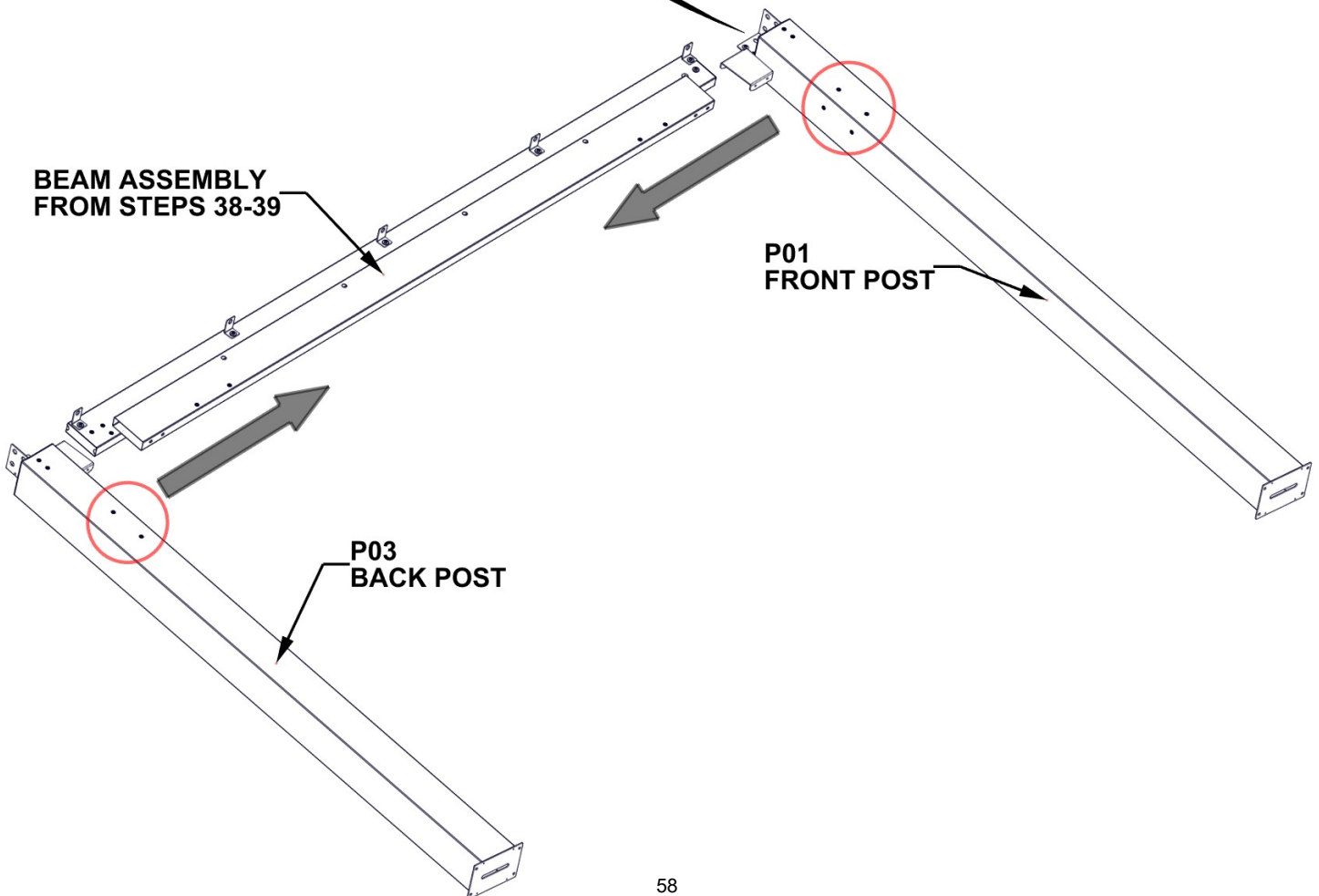

BEAM ASSEMBLY FROM STEPS 38-39

P01 FRONT POST

P03 BACK POST

STEP 42B - RIGHT SIDE POST ASSEMBLY

Qty	PART NUMBER	Description
6	H101101	TORX PAN HEAD 1/4-20x3/4"
6	H101054	SEALANT WASHER
6	H101053	STEEL WASHER 6x20

DO NOT FULLY TIGHTEN BOLTS AT THIS STEP

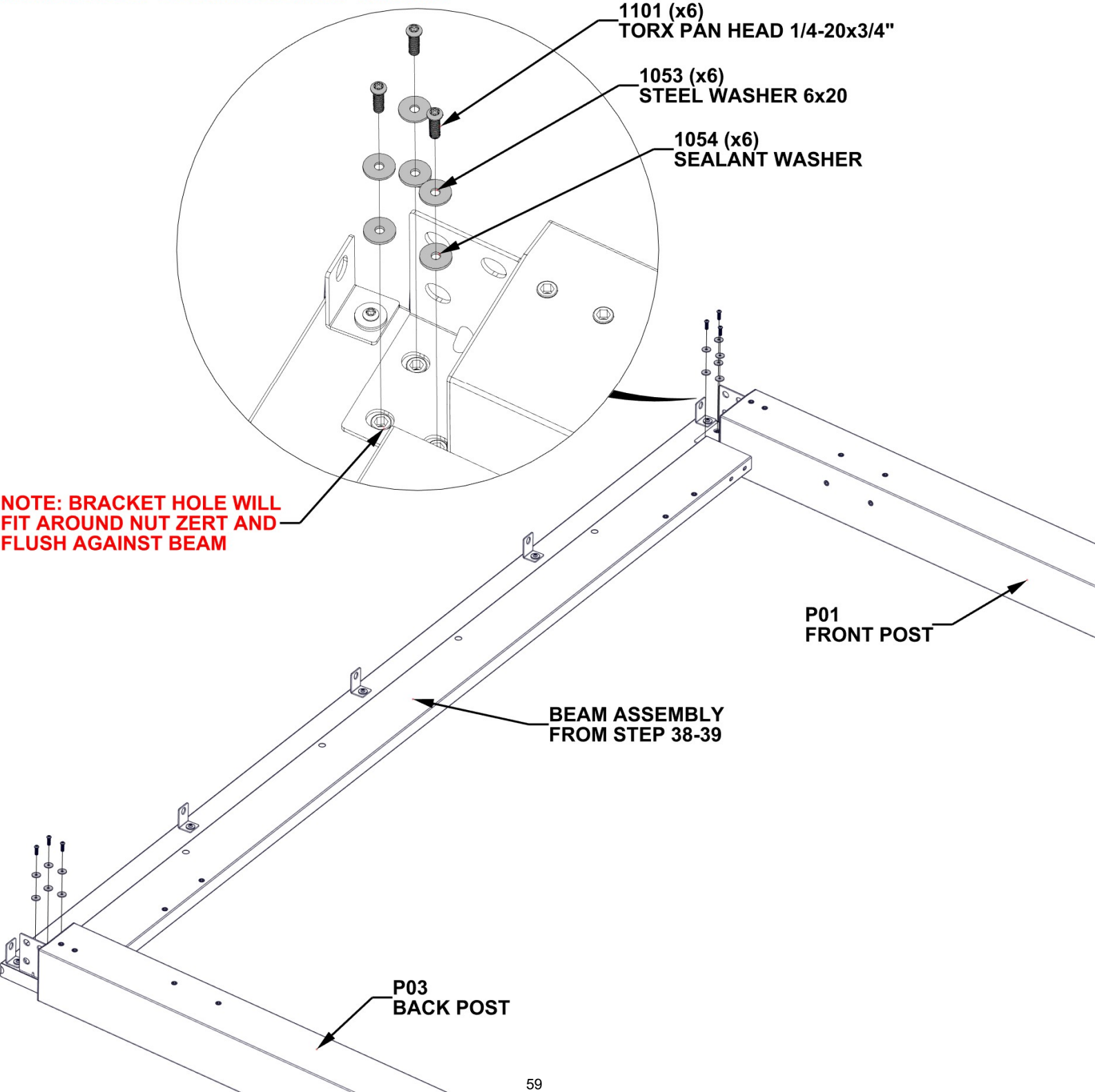

STEP 42C - RIGHT SIDE POST ASSEMBLY

Qty	PART NUMBER	Description
8	H101101	TORX PAN HEAD 1/4-20x3/4"
8	H101053	STEEL WASHER 6x20
8	H101054	SEALANT WASHER

DO NOT FULLY TIGHTEN BOLTS AT THIS STEP

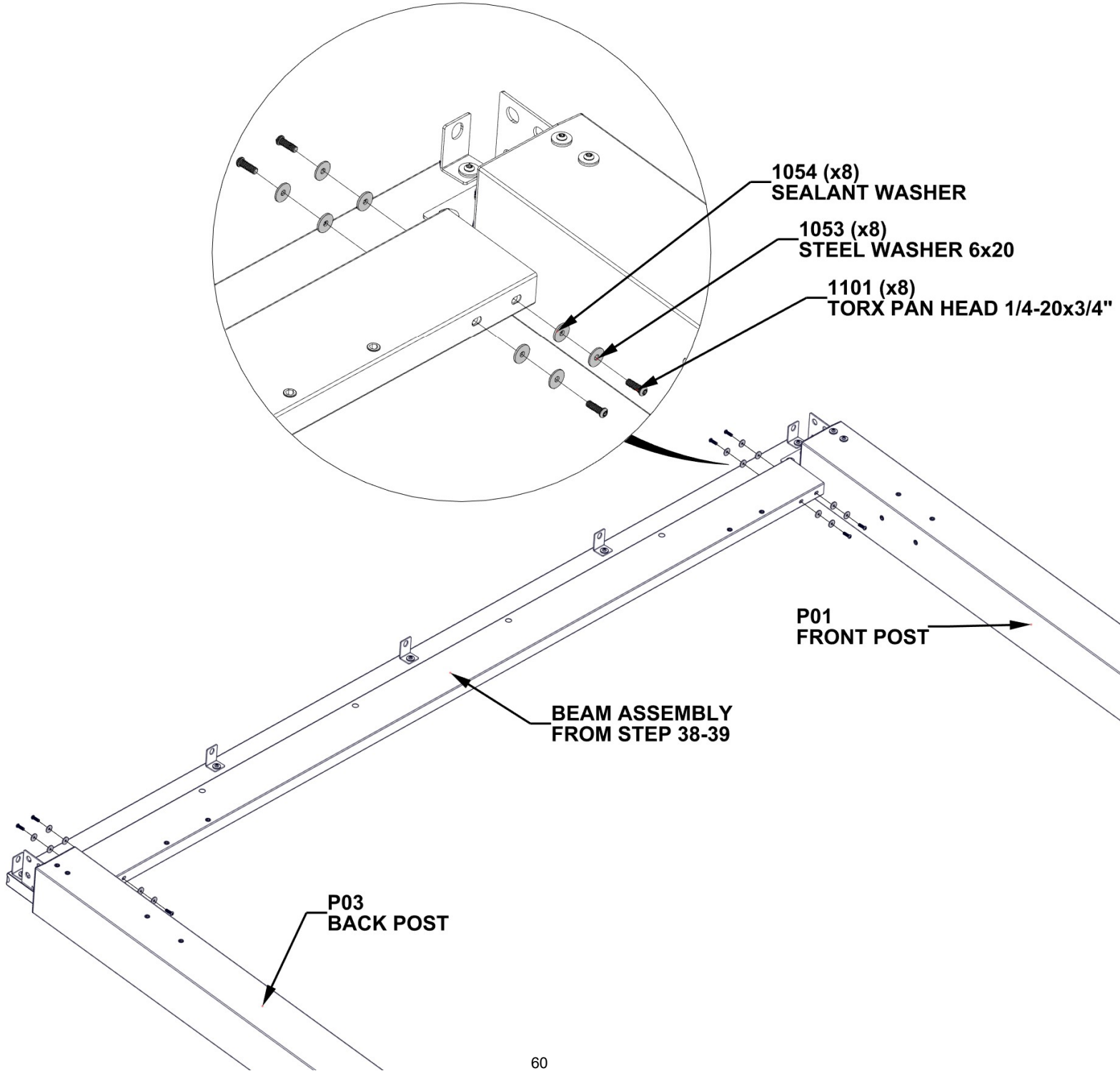

STEP 43 - RIGHT SIDE POST ASSEMBLY

Qty	PART NUMBER	Description
8	H101054	SEALANT WASHER
8	H101053	STEEL WASHER 6x20
8	H101101	TORX PAN HEAD 1/4-20x3/4"



D05 CORBEL - A4M01831
(x1) 2 3/4"x5 7/8"x24 13/16" (70x149x631)



D03 CORBEL - A4M01826
(x1) 2 3/4"x5 11/16"x20 1/16" (70x145x509)

**ATTACH CORBELS TO BEAM AND POST.
SQUARE AS NEEDED BEFORE TIGHTENING
ALL HARDWARE FROM PREVIOUS STEPS.**

1101 (x8)
TORX PAN HEAD 1/4-20x3/4"

1053 (x8)
STEEL WASHER 6x20

1054 (x8)
SEALANT WASHER

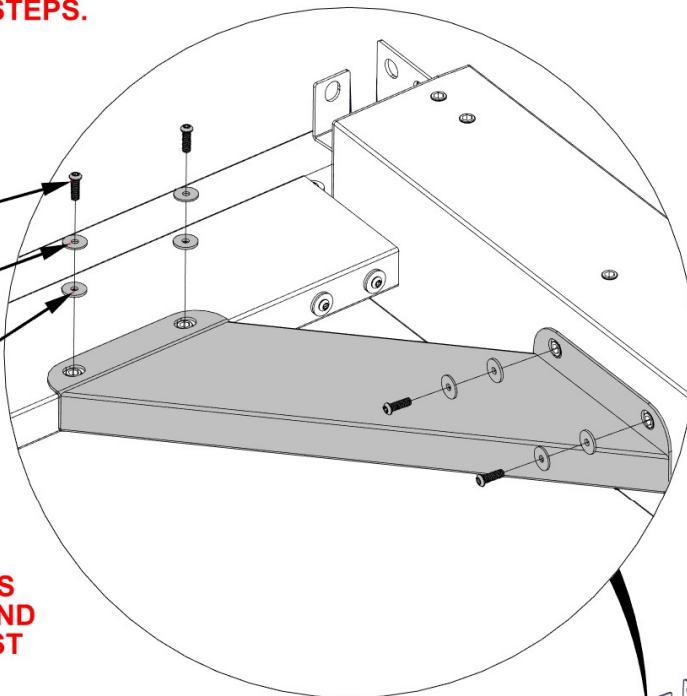

**NOTE: CORBEL BRACKET HOLES
WILL FIT AROUND NUT ZERTS AND
FLUSH AGAINST BEAM AND POST**

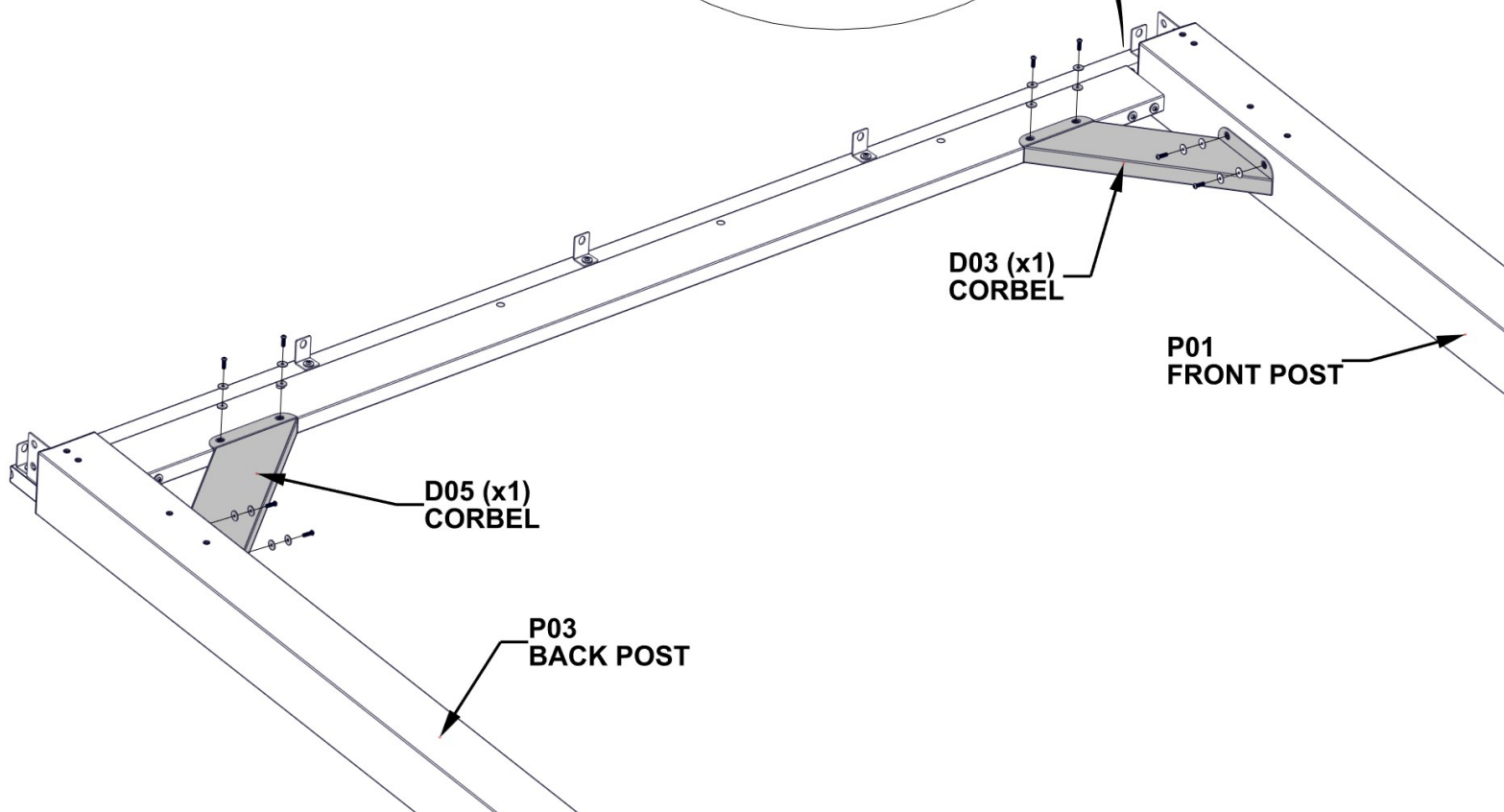

STEP 44 - RIGHT SIDE POST ASSEMBLY

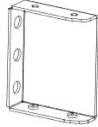

A4M01814 BEAM BRACKET
(x2)

Qty	PART NUMBER	Description
4	H101101	TORX PAN HEAD 1/4-20x3/4"
4	H101053	STEEL WASHER 6x20
4	H101054	SEALANT WASHER

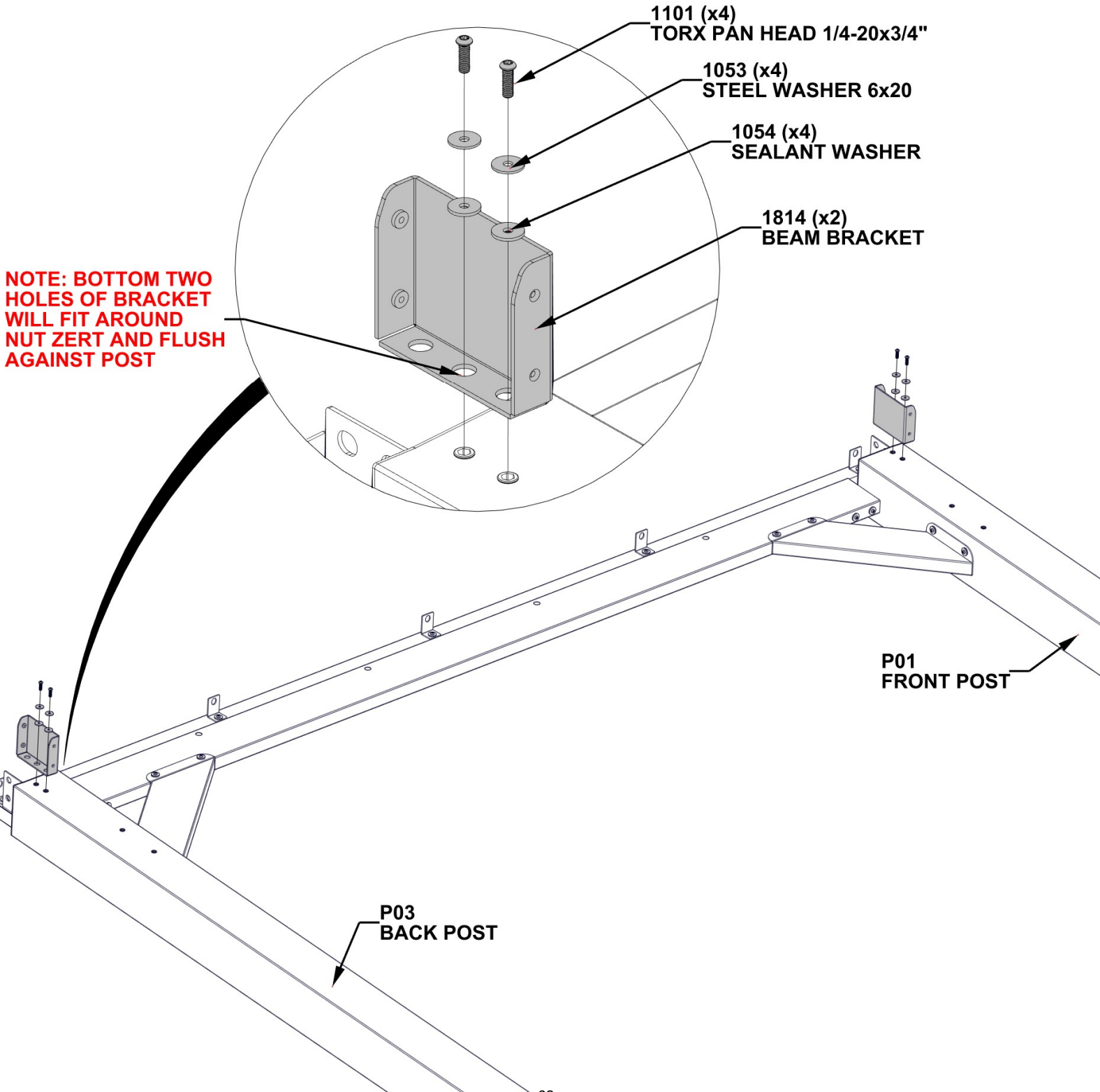

STEP 45 - FRONT BEAM ASSEMBLY

Qty	PART NUMBER	Description
3	H101103	TORX SOCKET SCREW 1/4-20



B01 BEAM - A4M01963
(x1) 1 3/8"x5 1/4"x81 7/8" (36x134x2080)



B04 BEAM - A4M01966
(x1) 1 3/8"x5 1/4"x76 1/4" (36x134x1936)

DO NOT FULLY TIGHTEN BOLTS AT THIS STEP

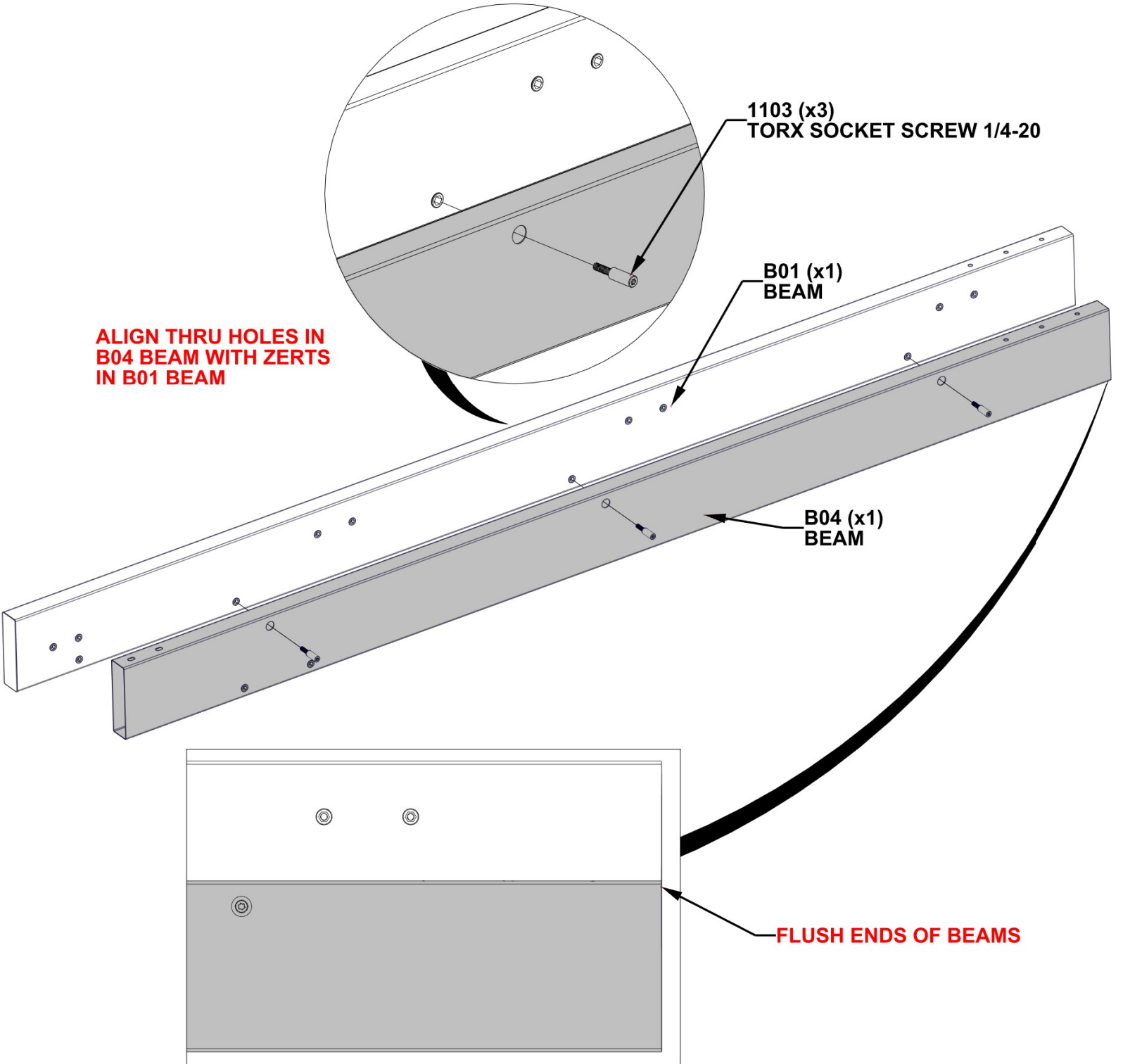

STEP 46 - FRONT BEAM ASSEMBLY

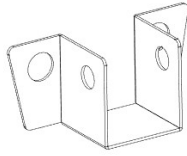

A4M01834 RAFTER BRACKET
(x3)

Qty	PART NUMBER	Description
6	H101101	TORX PAN HEAD 1/4-20x3/4"
6	H101053	STEEL WASHER 6x20
6	H101054	SEALANT WASHER

1834 (x3)
RAFTER BRACKET

NOTE: BRACKET HOLE WILL FIT AROUND NUT ZERT AND FLUSH AGAINST BEAM

1054 (x6)
SEALANT WASHER

1053 (x6)
STEEL WASHER 6x20

1101 (x6)
TORX PAN HEAD 1/4-20x3/4"

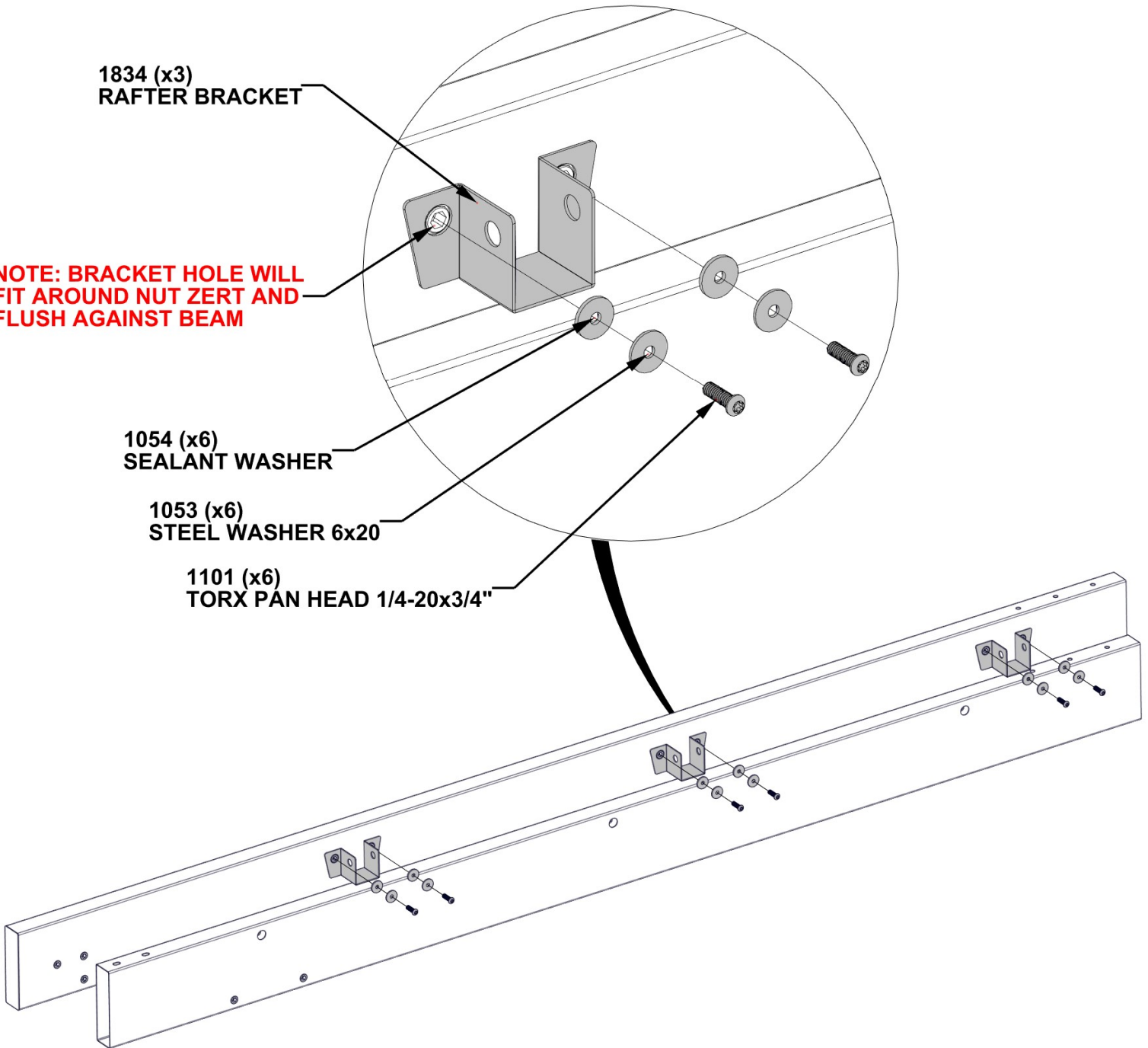

STEP 47 - BACK BEAM ASSEMBLY

Qty	PART NUMBER	Description
3	H101103	TORX SOCKET SCREW 1/4-20

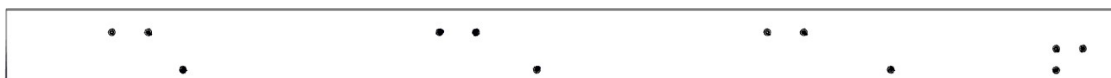

B03 BEAM - A4M01964
(x1) 1 3/8"x5 1/4"x81 7/8" (36x134x2080)



B11 BEAM - A4M01967
(x1) 1 3/8"x5 1/4"x76 1/4" (36x134x1936)

DO NOT FULLY TIGHTEN BOLTS AT THIS STEP

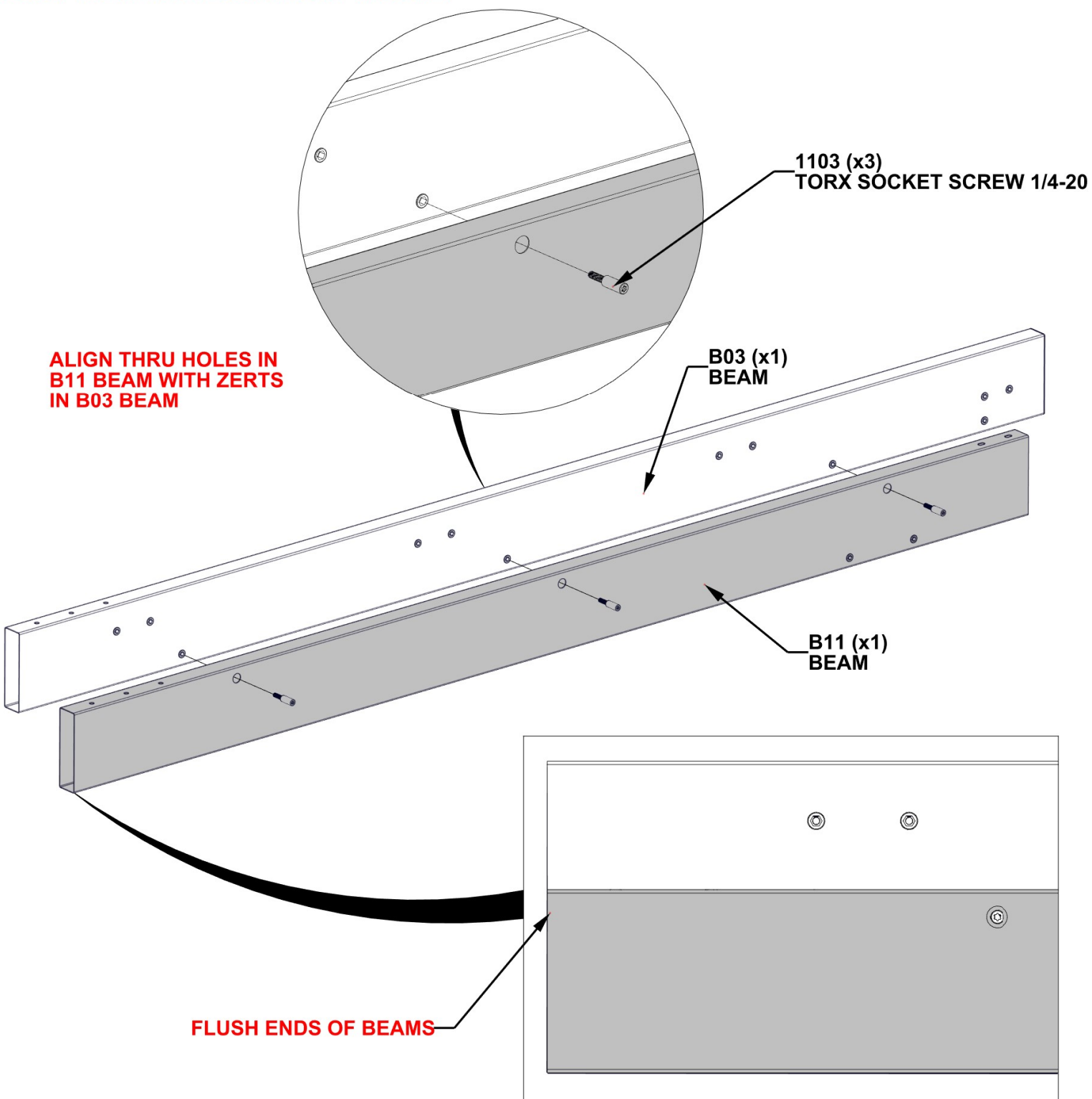

STEP 48 - BACK BEAM ASSEMBLY

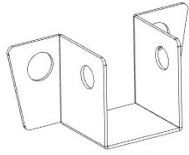

A4M01834 RAFTER BRACKET
(x3)

Qty	PART NUMBER	Description
6	H101101	TORX PAN HEAD 1/4-20x3/4"
6	H101054	SEALANT WASHER
6	H101053	STEEL WASHER 6x20

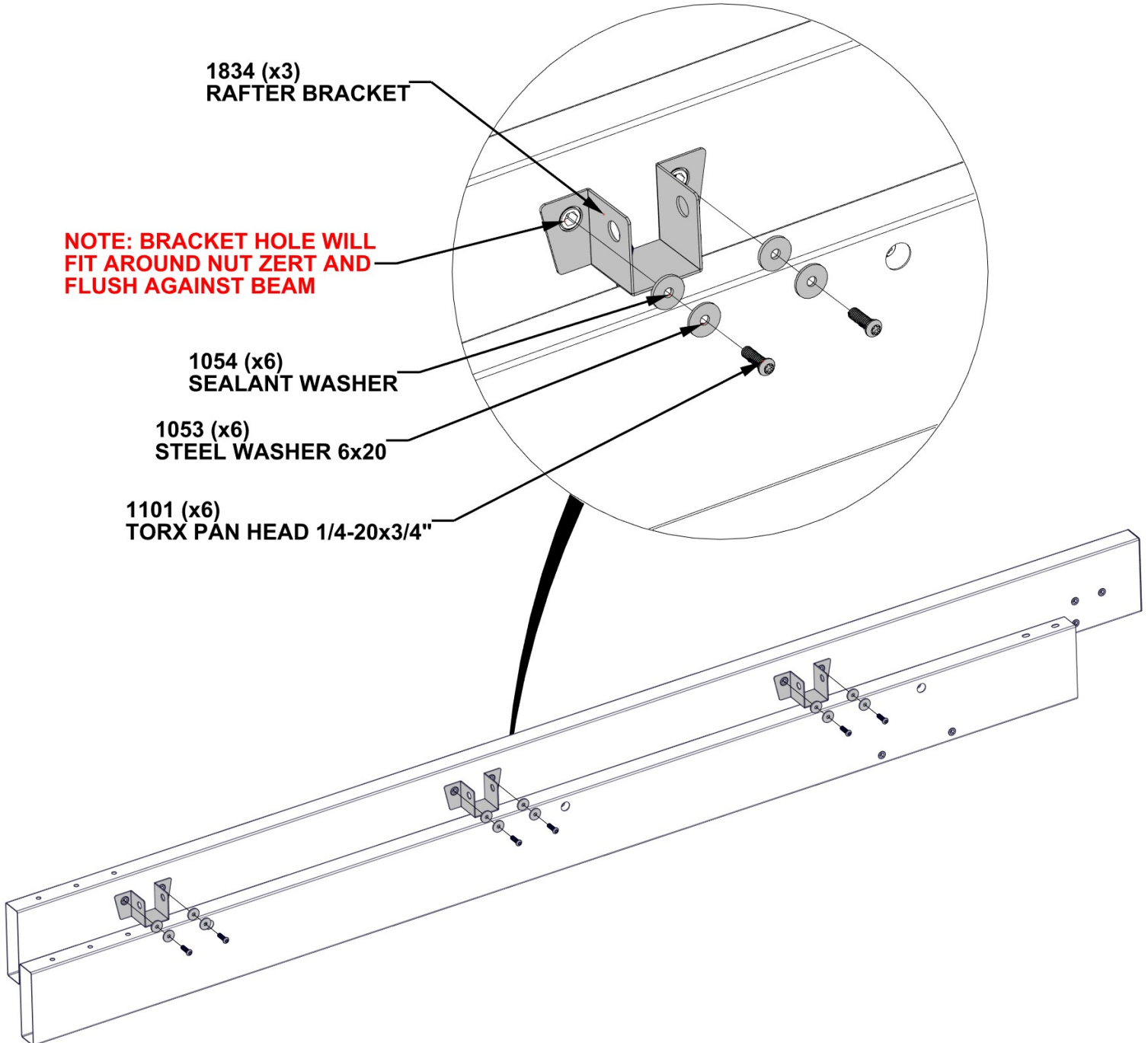

STEP 49A - GAZEBO ASSEMBLY

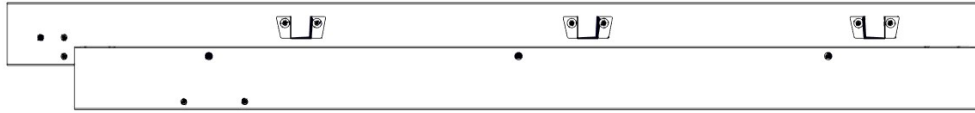

FRONT BEAM ASSEMBLY STEPS 45-46

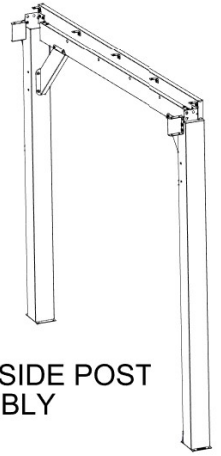

RIGHT SIDE POST ASSEMBLY

BEFORE BEGINNING, HAVE HARDWARE PREPARED FOR STEPS 49B AND 49C.

FOR THIS STEP IT IS HELPFUL TO HAVE TWO ADDITIONAL PEOPLE TO HELP STAND UP ASSEMBLY AND TO SLIDE FRONT BEAM ASSEMBLY INTO PLACE.

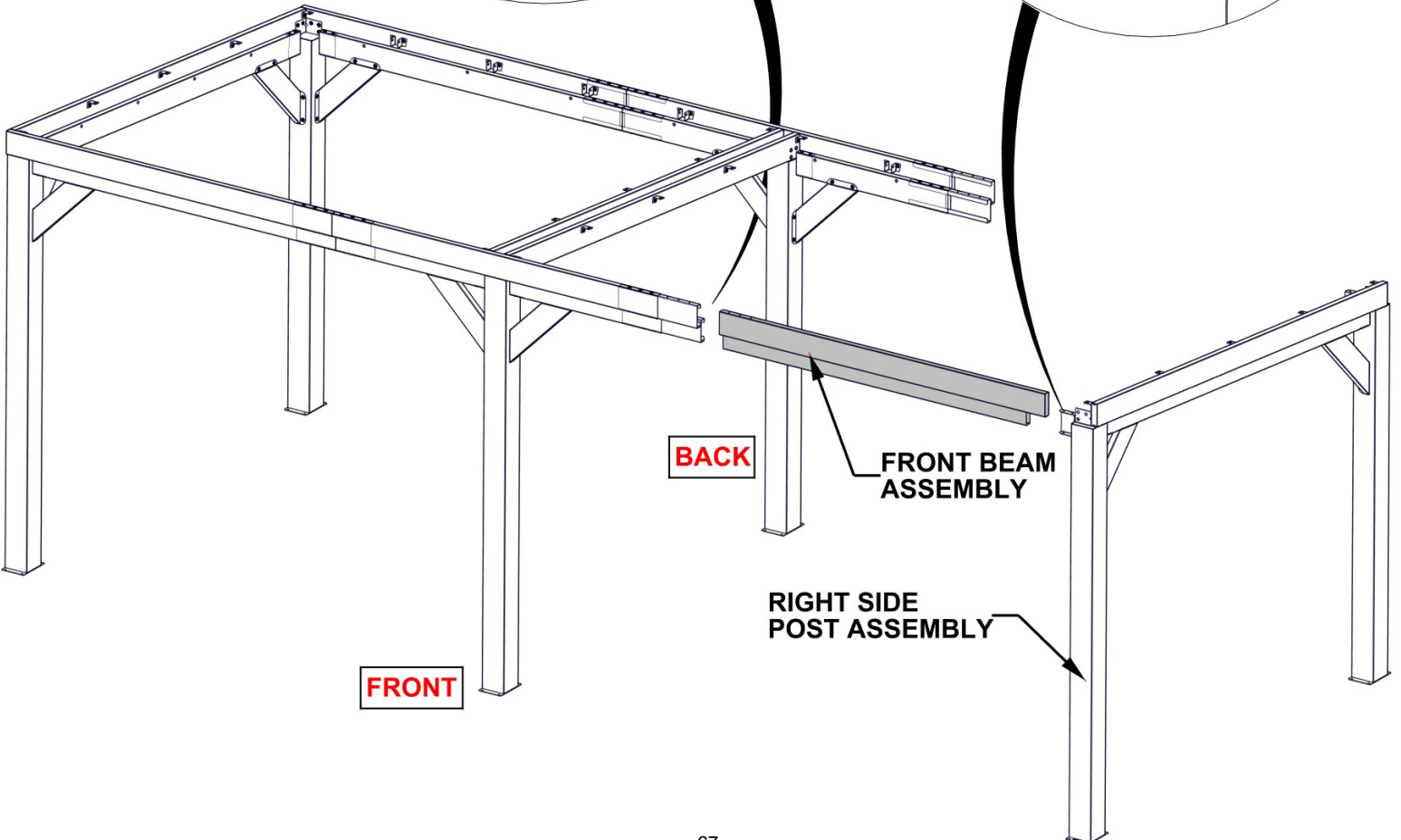
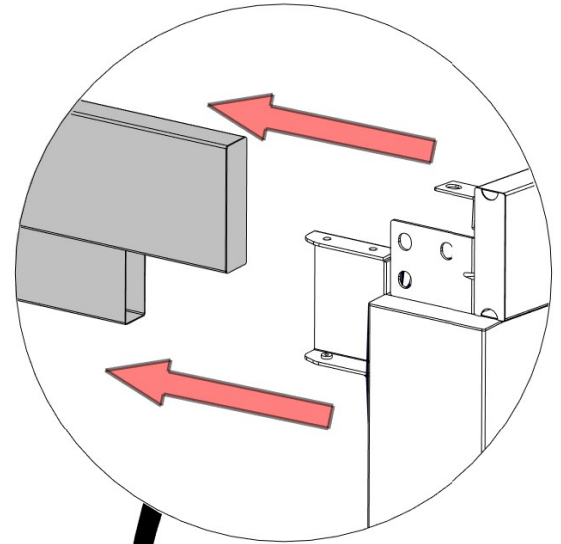
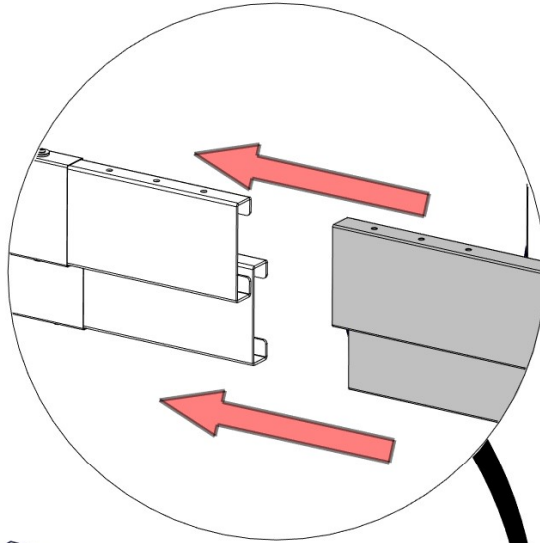

STEP 49B - GAZEBO ASSEMBLY

Qty	PART NUMBER	Description
3	H101101	TORX PAN HEAD 1/4-20x3/4"
3	H101053	STEEL WASHER 6x20
3	H101054	SEALANT WASHER

DO NOT FULLY TIGHTEN BOLTS AT THIS STEP

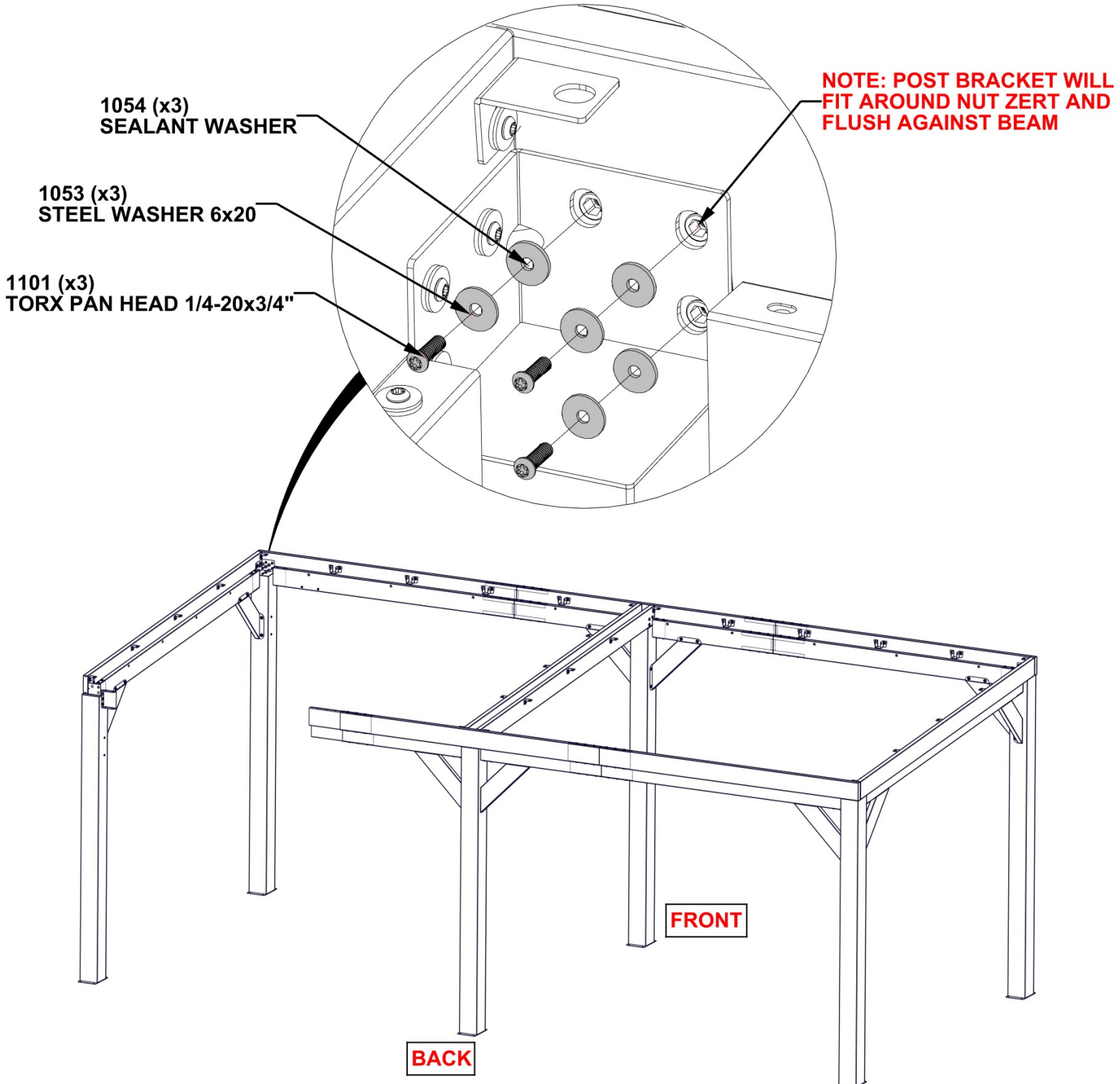

STEP 49C - GAZEBO ASSEMBLY

Qty	PART NUMBER	Description
16	H101101	TORX PAN HEAD 1/4-20x3/4"
16	H101053	STEEL WASHER 6x20
16	H101054	SEALANT WASHER

DO NOT FULLY TIGHTEN BOLTS AT THIS STEP

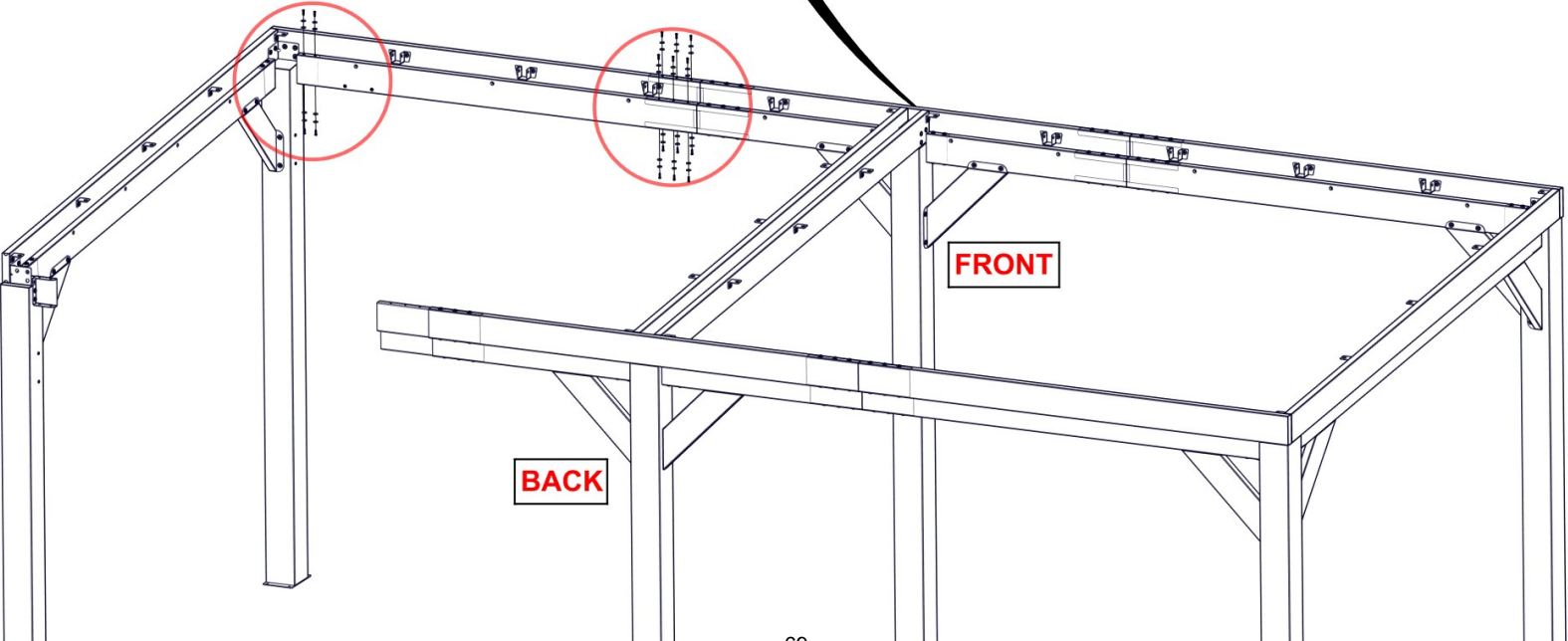
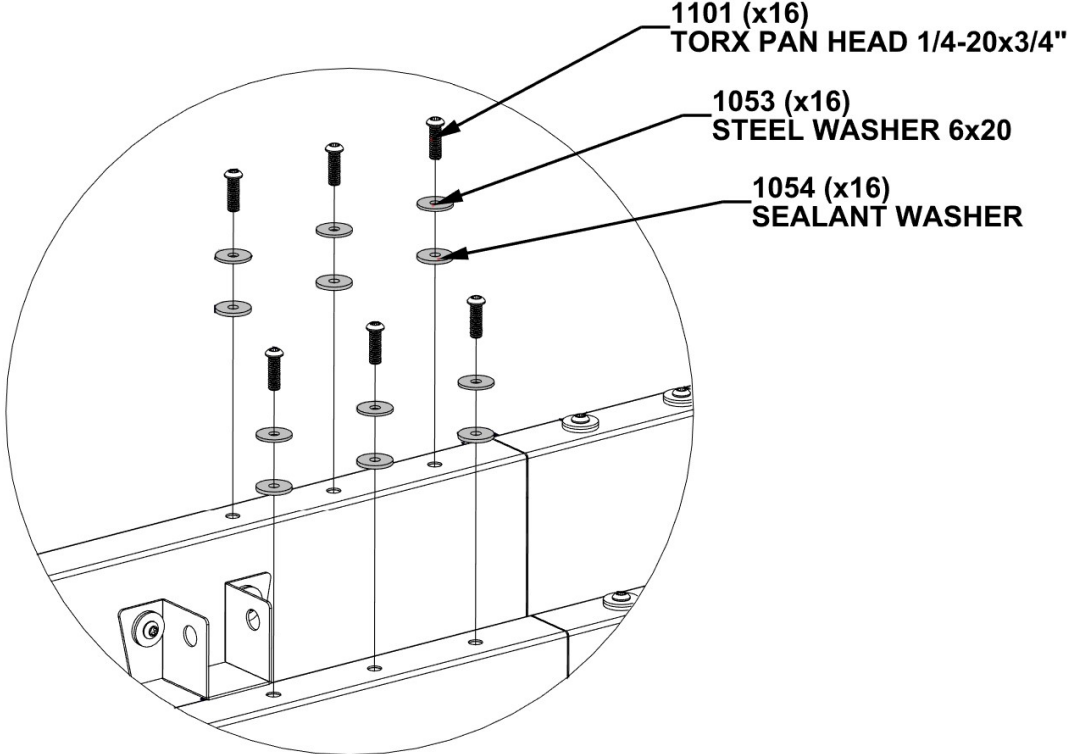

STEP 50 - GAZEBO ASSEMBLY



D01 CORBEL - A4M01817
(x1) 2 3/4"x5 13/16"x22 1/4" (70x147x565)

Qty	PART NUMBER	Description
4	H101101	TORX PAN HEAD 1/4-20x3/4"
4	H101053	STEEL WASHER 6x20
4	H101054	SEALANT WASHER

DO NOT FULLY TIGHTEN BOLTS AT THIS STEP

NOTE: CORBEL BRACKETS WILL FIT AROUND NUT ZERTS AND FLUSH AGAINST BEAM AND POST.

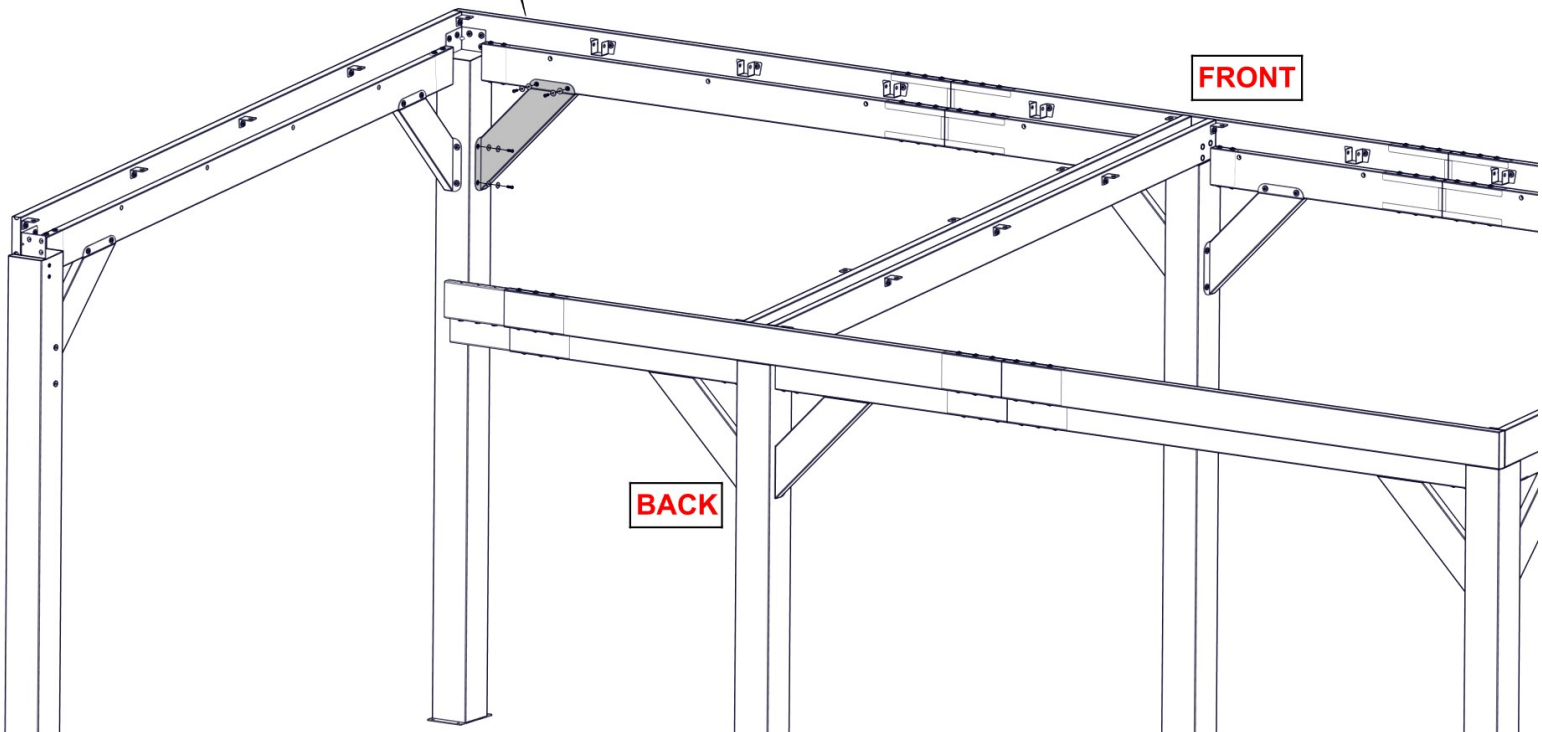
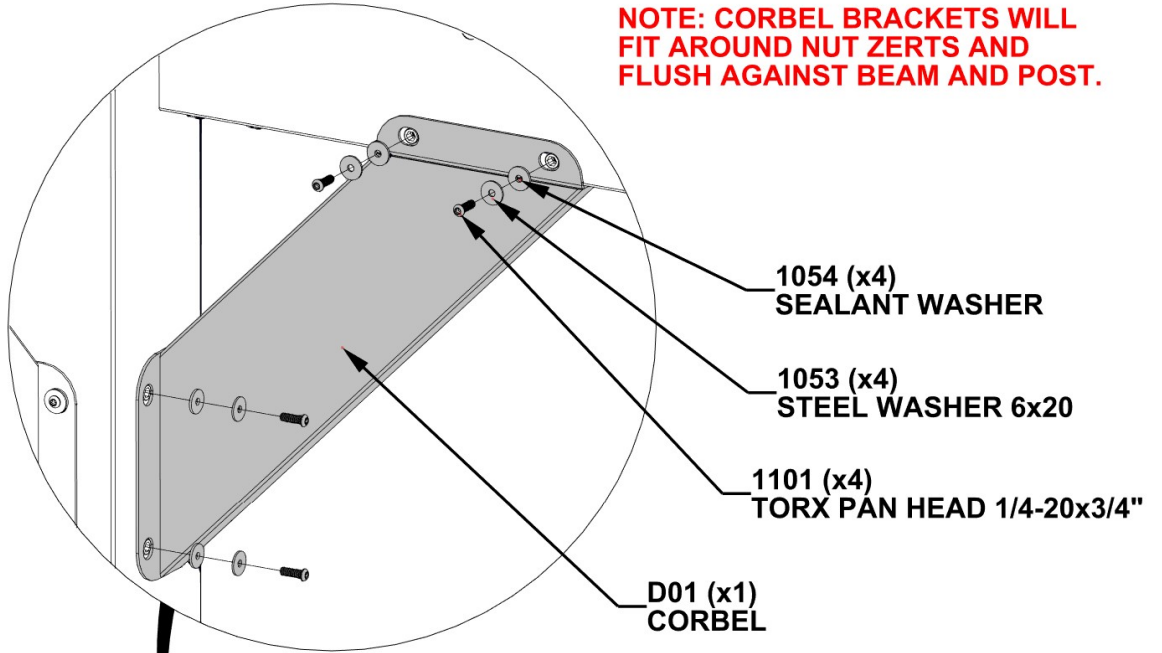

STEP 51A - GAZEBO ASSEMBLY

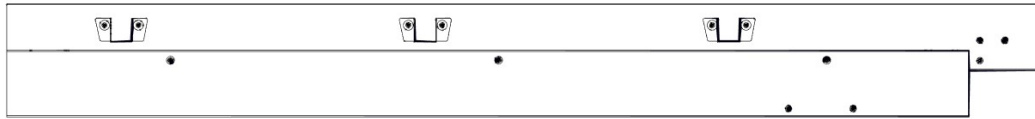

BACK BEAM ASSEMBLY STEPS 47-48

BEFORE BEGINNING, HAVE HARDWARE PREPARED FOR STEPS 51B AND 51C.

FOR THIS STEP IT IS HELPFUL TO HAVE TWO ADDITIONAL PEOPLE TO HELP MOVE BACK CORNER POST OUTWARD TO BE ABLE TO SLIDE BEAM ASSEMBLY INTO PLACE

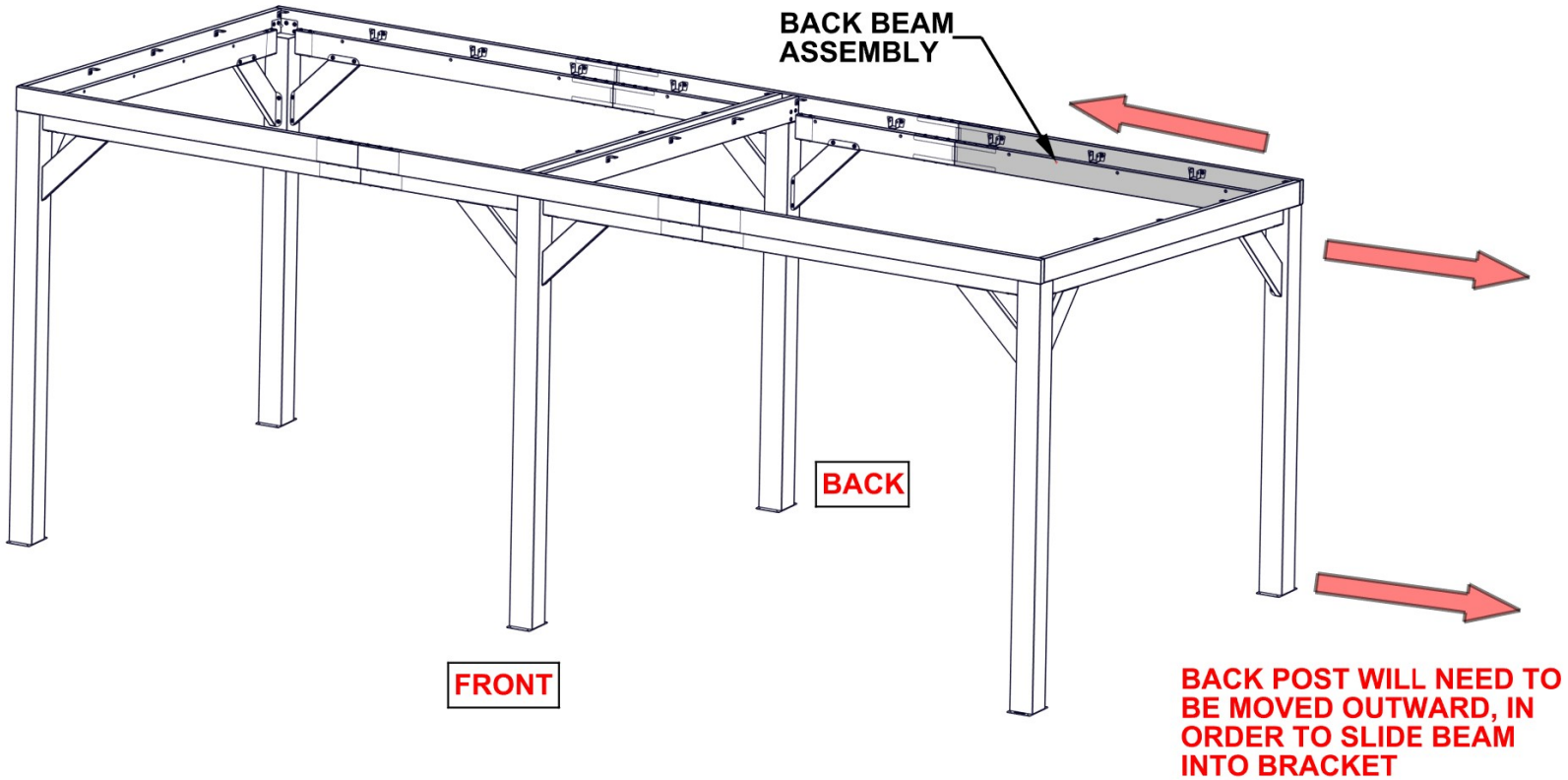

STEP 51B - GAZEBO ASSEMBLY

Qty	PART NUMBER	Description
3	H101101	TORX PAN HEAD 1/4-20x3/4"
3	H101053	STEEL WASHER 6x20
3	H101054	SEALANT WASHER

DO NOT FULLY TIGHTEN BOLTS AT THIS STEP

NOTE: POST BRACKET WILL FIT AROUND NUT ZERT AND FLUSH AGAINST BEAM

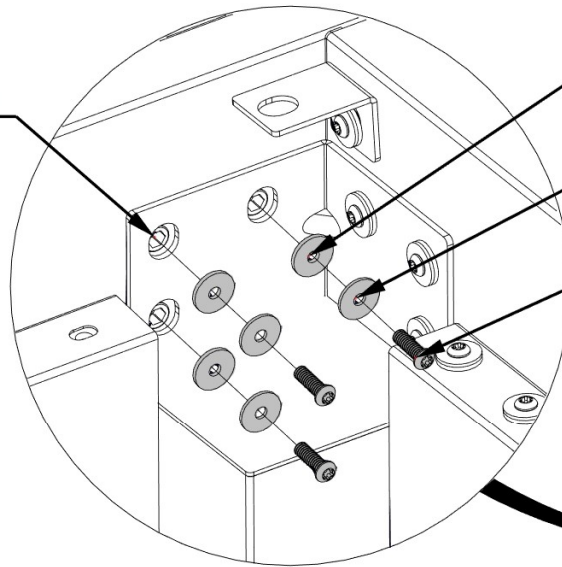

**1054 (x3)
SEALANT WASHER**

**1053 (x3)
STEEL WASHER 6x20**

**1101 (x3)
TORX PAN HEAD 1/4-20x3/4"**

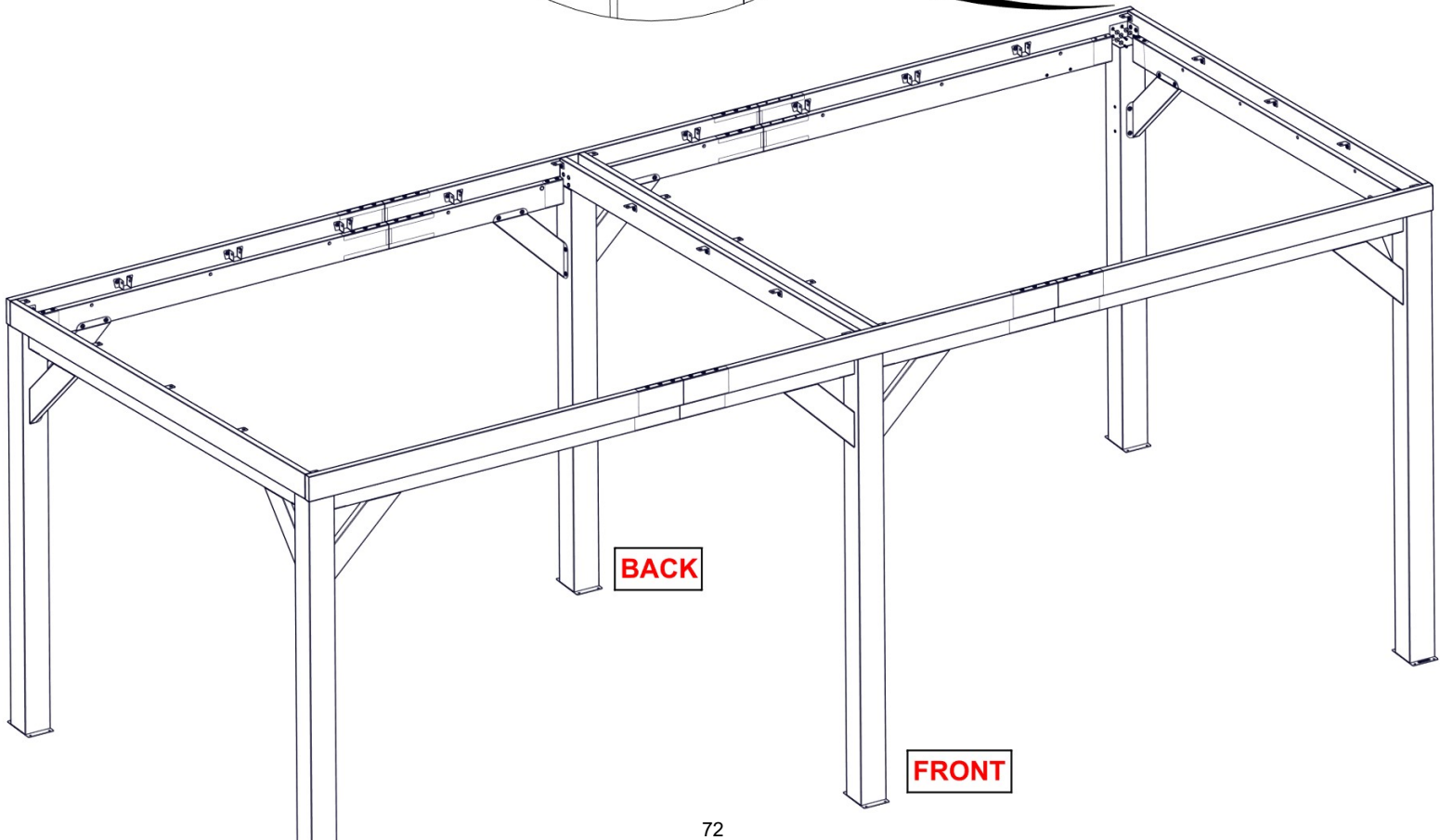

BACK

FRONT

STEP 51C - GAZEBO ASSEMBLY

Qty	PART NUMBER	Description
16	H101101	TORX PAN HEAD 1/4-20x3/4"
16	H101053	STEEL WASHER 6x20
16	H101054	SEALANT WASHER

DO NOT FULLY TIGHTEN BOLTS AT THIS STEP

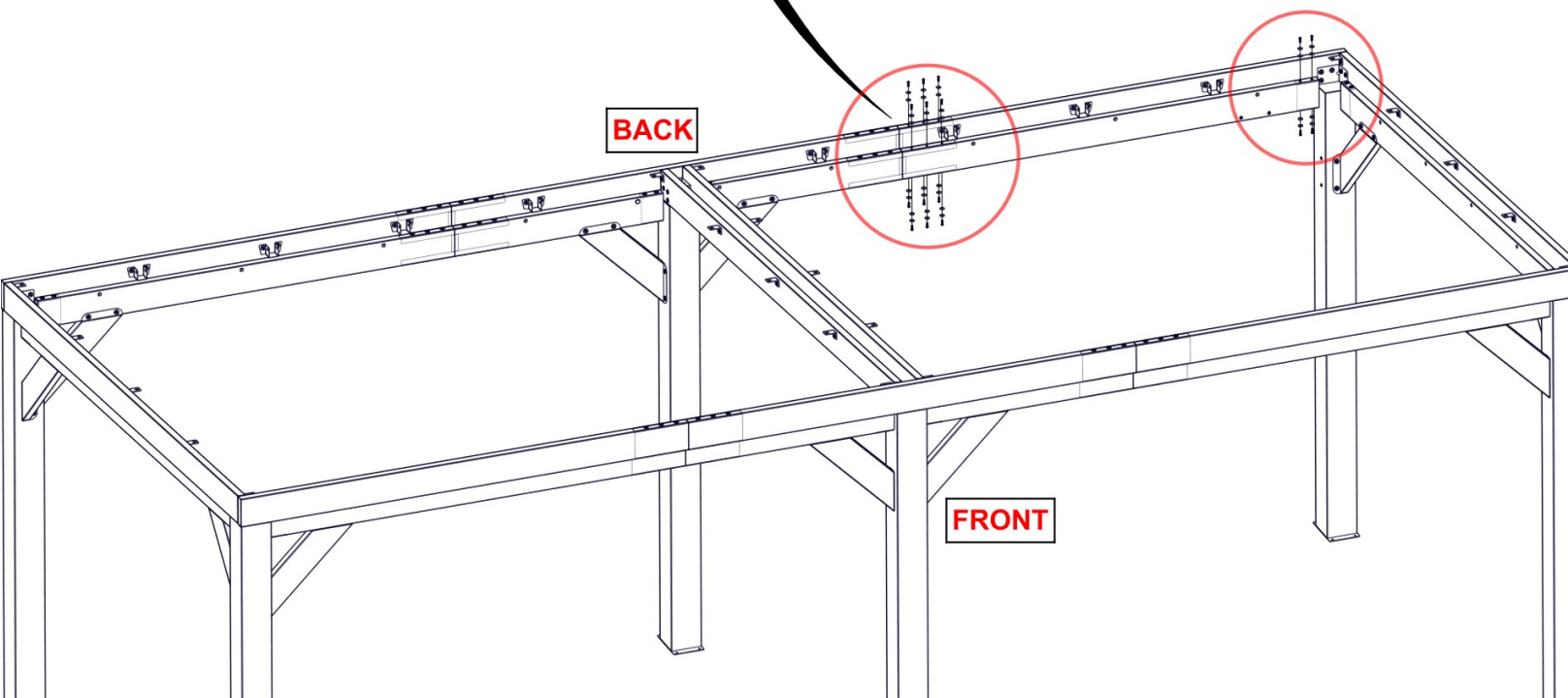
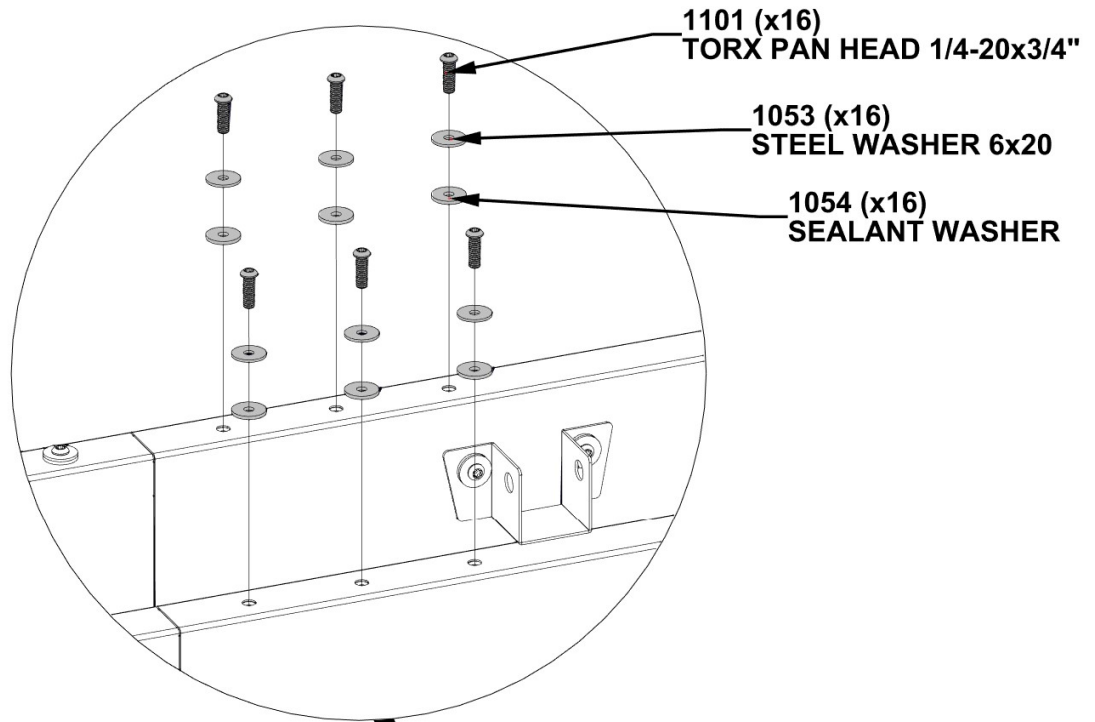

STEP 52 - GAZEBO ASSEMBLY



D02 CORBEL - A4M01818
(x1) 2 3/4"x5 13/16"x22 1/4" (70x147x565)

Qty	PART NUMBER	Description
4	H101101	TORX PAN HEAD 1/4-20x3/4"
4	H101053	STEEL WASHER 6x20
4	H101054	SEALANT WASHER

DO NOT FULLY TIGHTEN BOLTS AT THIS STEP

NOTE: CORBEL BRACKETS WILL FIT AROUND NUT ZERTS AND FLUSH AGAINST BEAM AND POST.

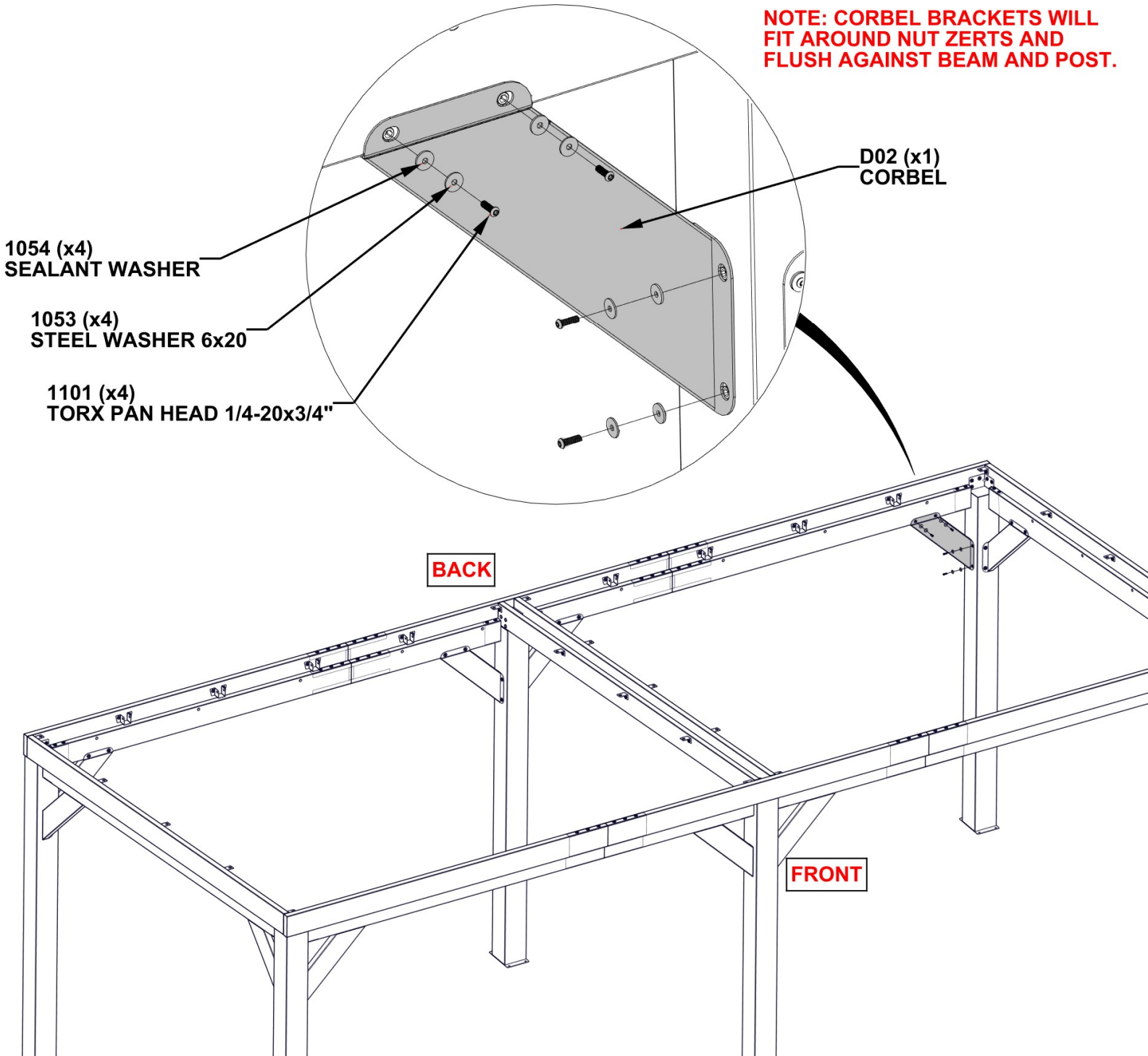

STEP 53 - SQUARE THE ASSEMBLY

**CRITICAL: SQUARE GAZEBO BEFORE PROCEEDING TO NEXT STEPS.
ONCE SQUARE, TIGHTEN ALL HARDWARE.**

MEASUREMENTS TAKEN FROM INSIDE OF POST TO INSIDE OF POST.

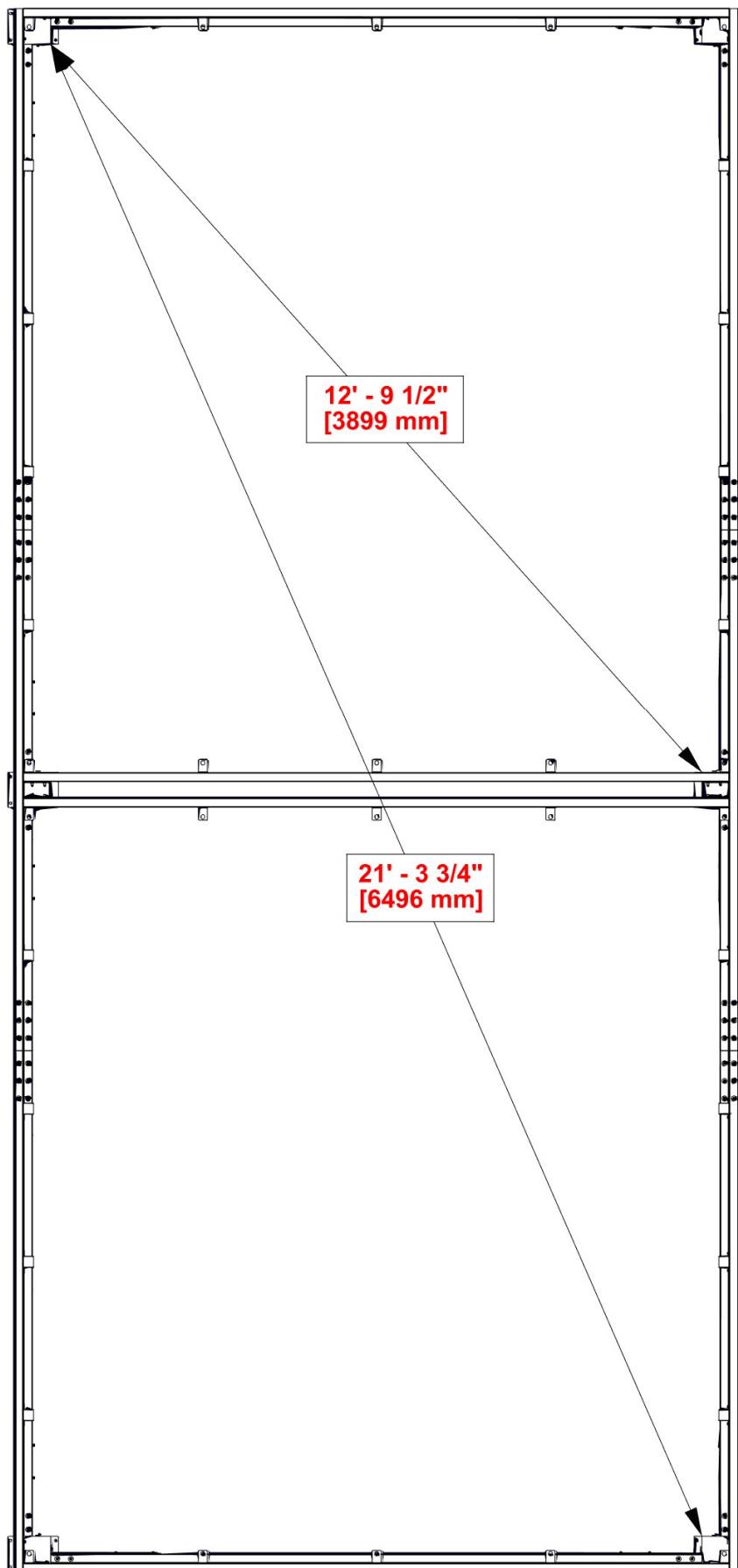

**BEFORE PROCEEDING, MAKE SURE ALL HARDWARE
IS TIGHTENED AND GAZEBO FRAME IS SQUARE.**

STEP 54 - GAZEBO ASSEMBLY



A4M01352 HOLE COVER
(x28)

**USE A SMALL PIECE OF WOOD AND
RUBBER Mallet TO TAP HOLE COVERS IN.**

**DO NOT TAP DIRECTLY WITH A HAMMER AS
YOU MAY DAMAGE THE POWDER COAT
FINISH ON PRODUCT.**

H1 (x28)
HOLE COVER

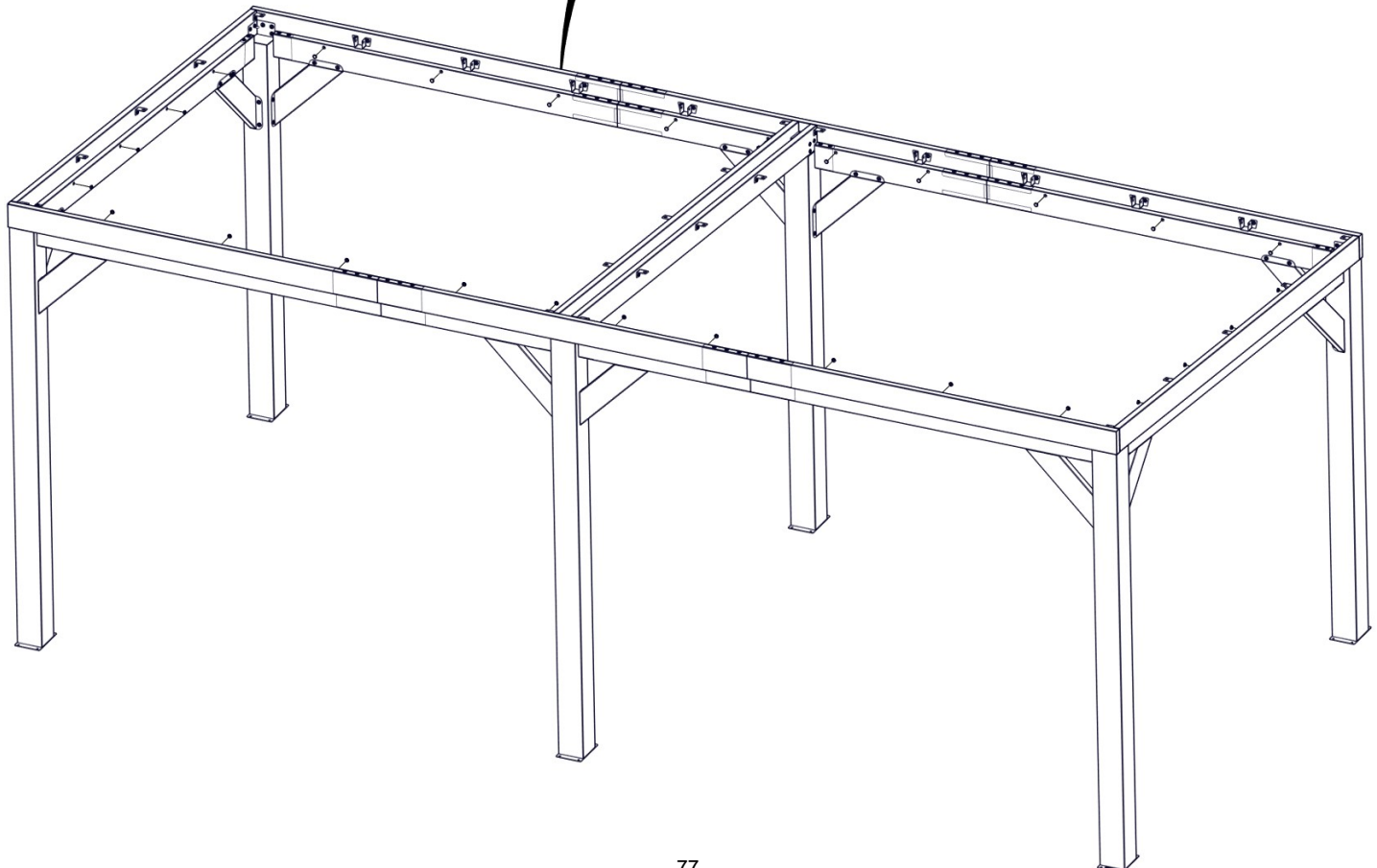
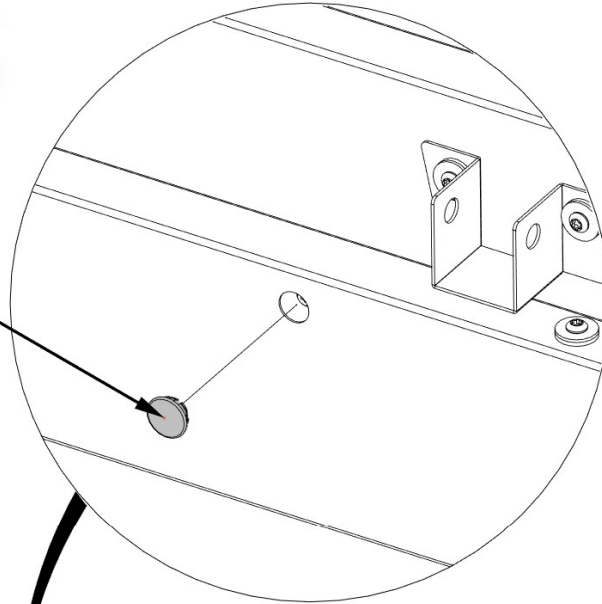

STEP 55 - ROOF ASSEMBLY

C01 RAFTER - A4M01833
 (x8) 1 5/8"x2 3/8"x111 1/2" (40x60x2831)

Qty	PART NUMBER	Description
16	H100653	NUT LOCK 1/4 BLK
16	H100630	WASHER FLAT 8x19 BLK
16	H100567	BOLT WH 1/4x2 1/4 BLK

DO NOT FULLY TIGHTEN BOLTS AT THIS STEP.

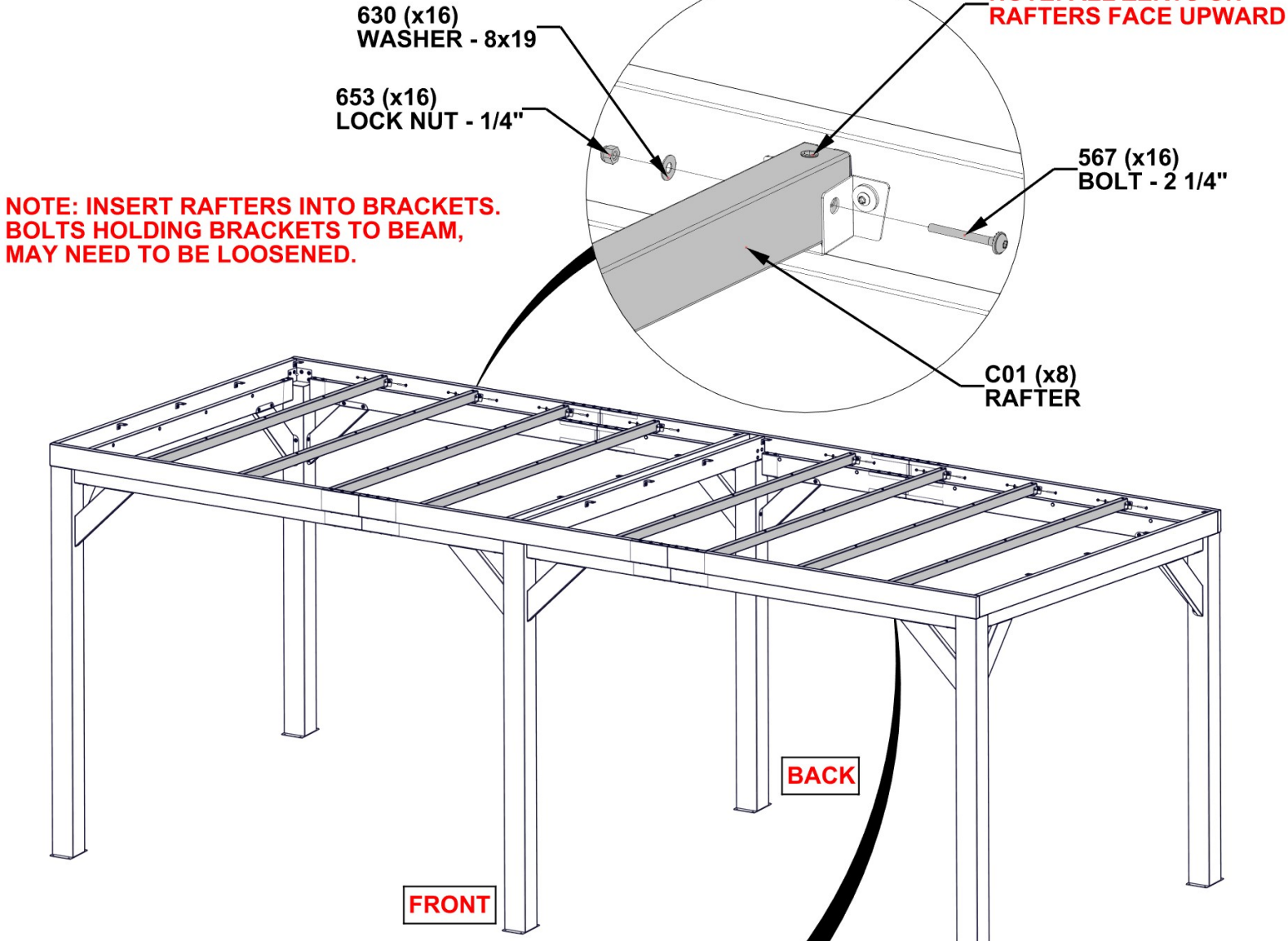

NOTE: RAFTER ENDS ARE ANGLED TO MATCH PITCH OF SLANT ROOF. ENDS SHOULD SIT FLUSH AGAINST BEAMS.

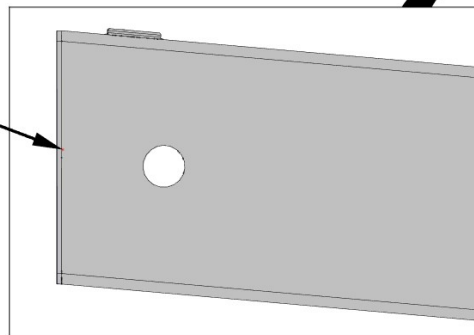

STEP 56 - PURLIN ASSEMBLY

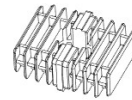

A6P00530 2-WAY SQUARE PLUG
(x10)



E01 PURLIN - A4M01975
(x10) 3/4"x1 5/8"x71 1/4" (20x40x1810)

COMPLETE THIS STEP 10 TIMES

USE A RUBBER Mallet TO TAP 2-WAY SQUARE PLUG INTO END OF PURLIN

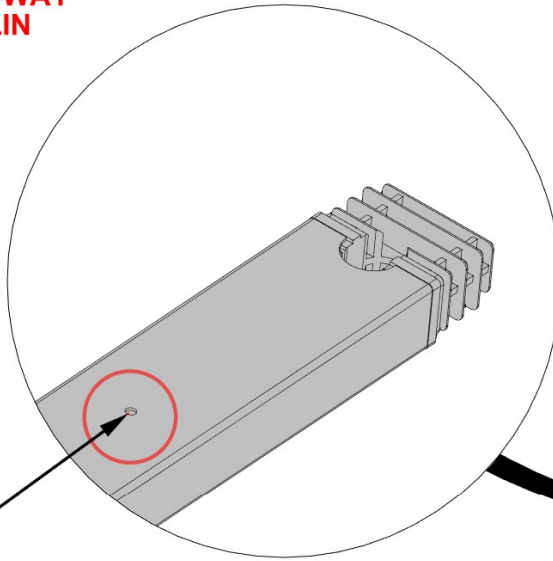

ENSURE E01 IS ORIENTED CORRECTLY WITH PILOT HOLES FACING UP

530 (x1)
2-WAY SQUARE PLUG

E01 (x1)
PURLIN

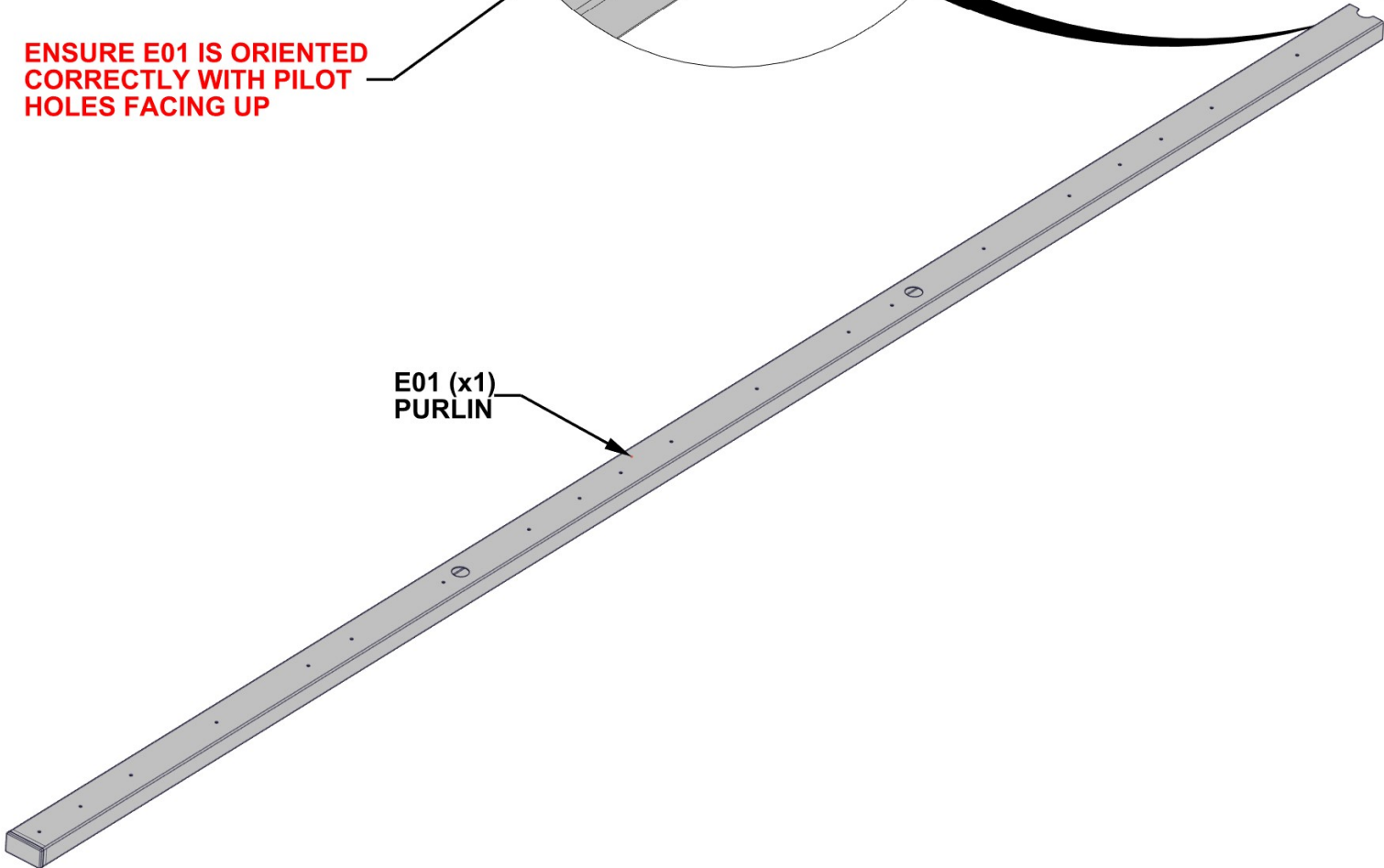

STEP 57 - PURLIN ASSEMBLY



E02 PURLIN - A4M01976
(x10) 3/4"x1 5/8"x47 1/8" (20x40x1198)

COMPLETE THIS STEP 10 TIMES

**USE A RUBBER Mallet TO TAP ENDS
OF EACH PURLIN UNTIL TIGHT
AGAINST 2-WAY PLUG**

**ENSURE E02 IS ORIENTED
CORRECTLY WITH PILOT
HOLES FACING UP**

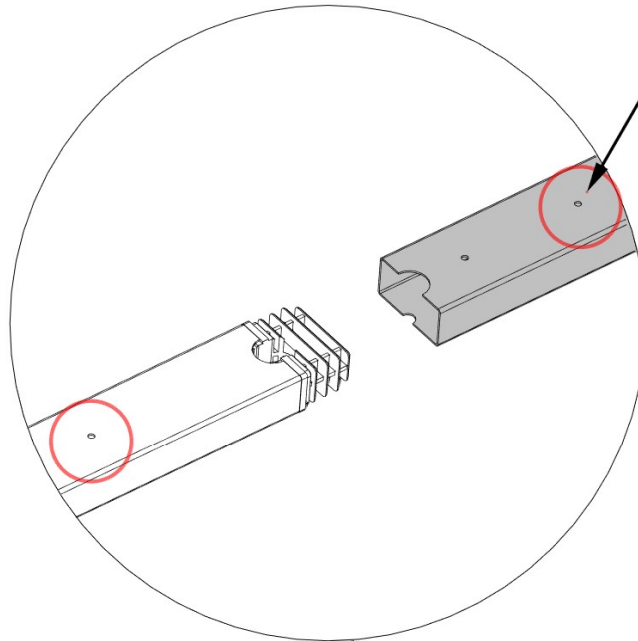

E02 (x1)
PURLIN

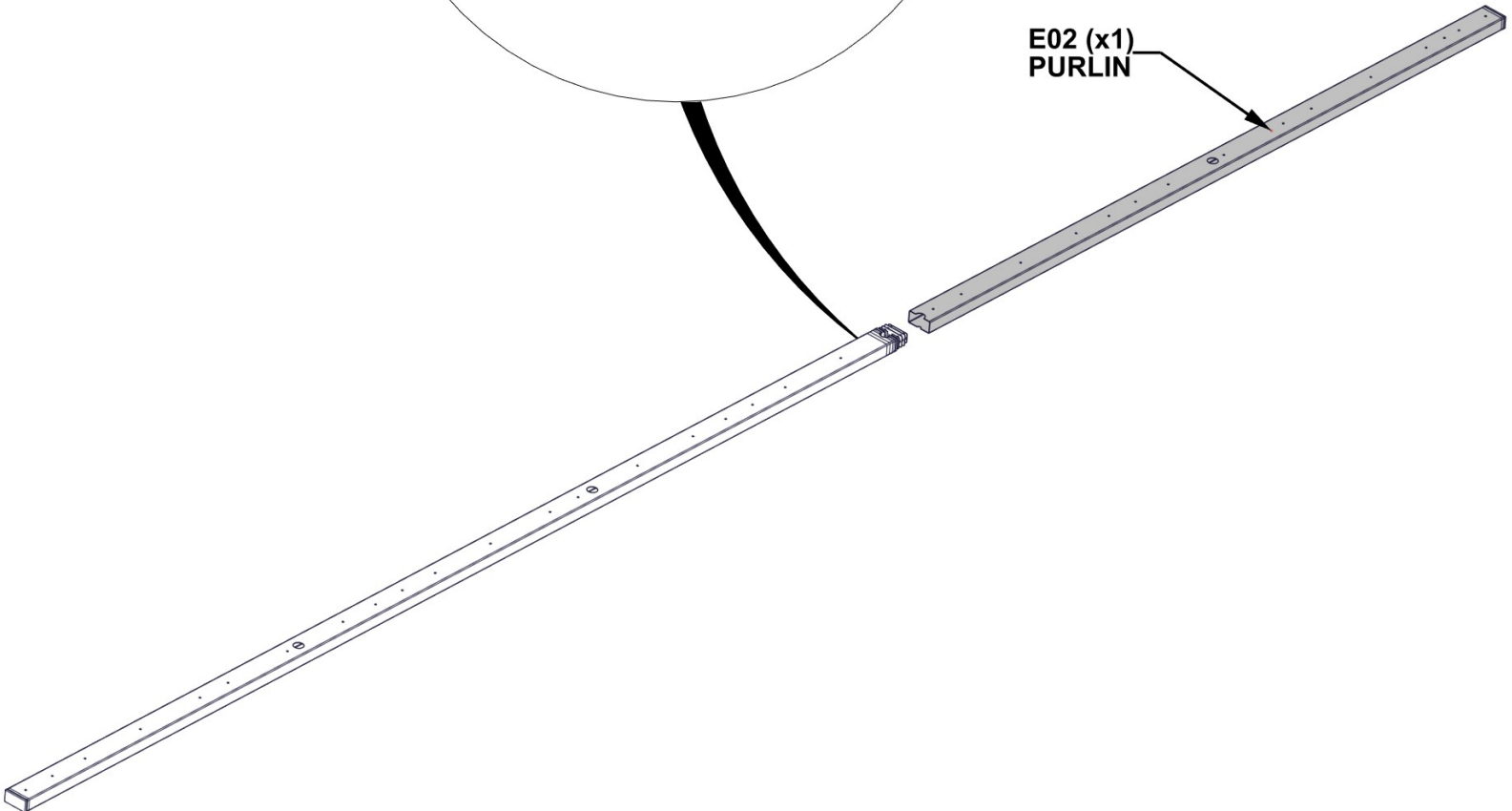

STEP 58 - ROOF ASSEMBLY



PURLIN ASSEMBLY STEPS 56-57

Qty	PART NUMBER	Description
40	H101132	TORX SOCKET SCREW 1/4-20

DO NOT FULLY TIGHTEN BOLTS AT THIS STEP

NOTE: MAKE SURE MIDDLE OF PURLIN ASSEMBLY IS SUPPORTED WHEN LIFTING

**1132 (x40)
TORX SOCKET SCREW 1/4-20**

PURLIN ASSEMBLY

START FROM THE BACK AND WORK TOWARDS THE FRONT OFFSETTING SPLICES CONNECTING PURLINS TOGETHER

NOTE: ALL PILOT HOLES IN PURLINS FACE UP

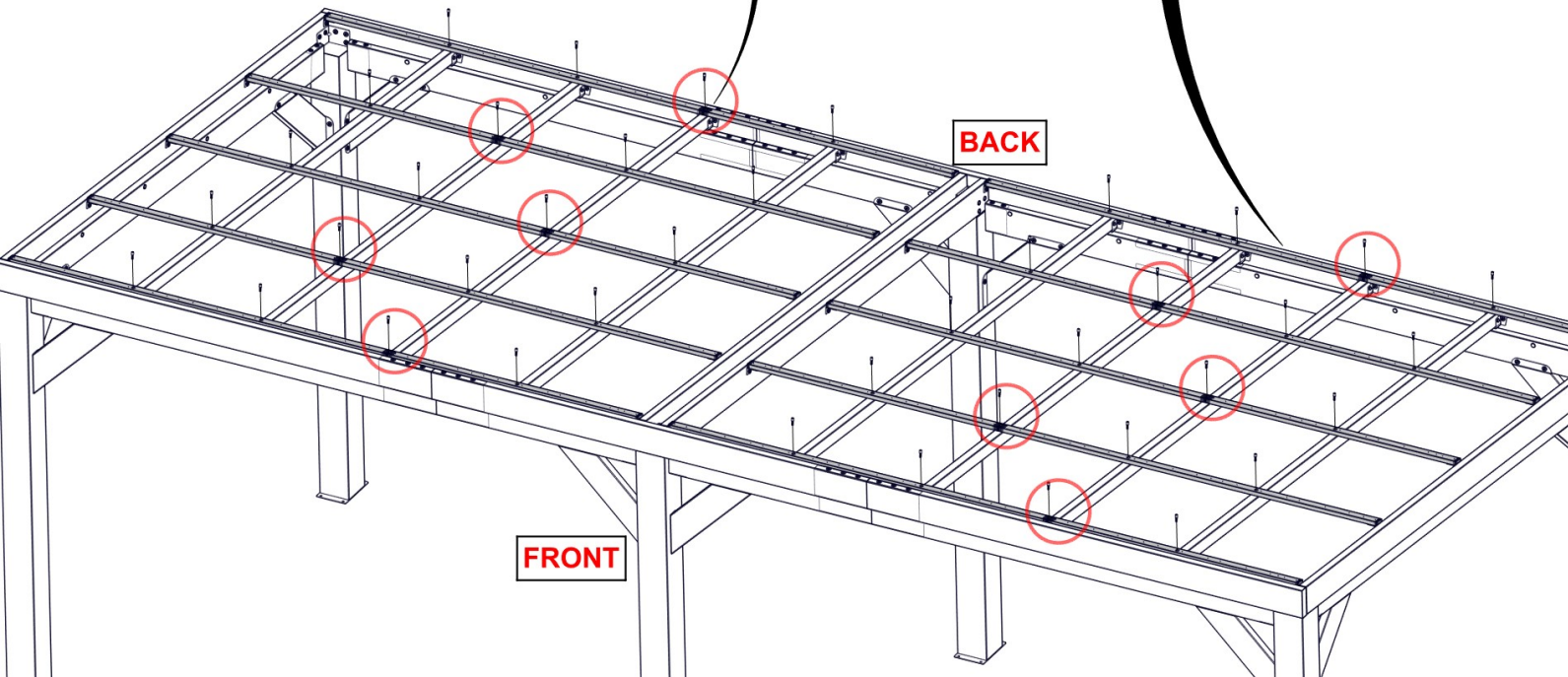
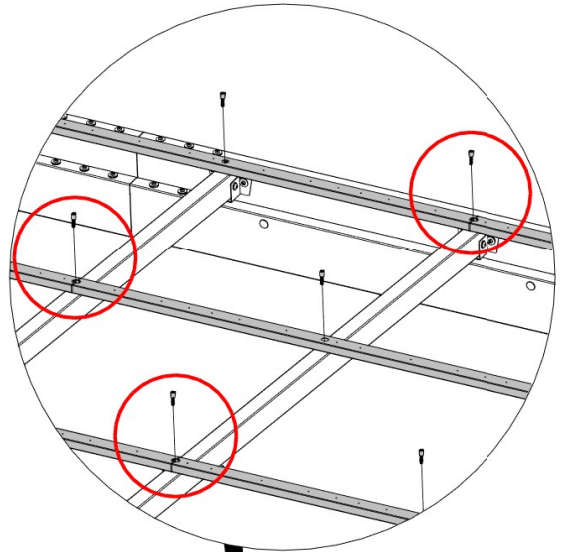
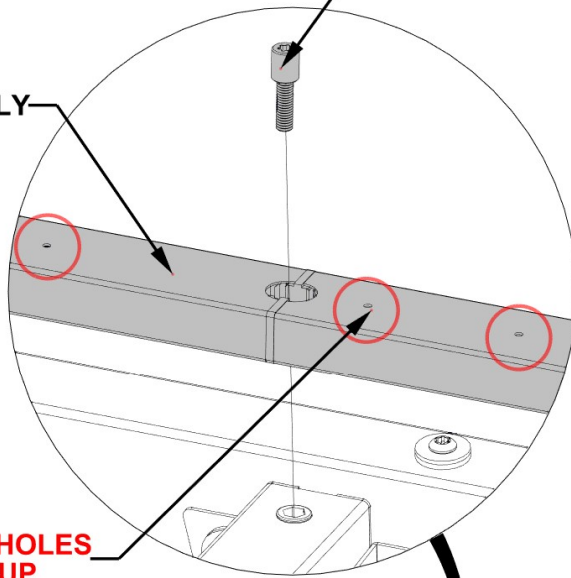

STEP 59 - ROOF ASSEMBLY

Qty	PART NUMBER	Description
20	H101101	TORX PAN HEAD 1/4-20x3/4"
20	H101053	STEEL WASHER 6x20
20	H101054	SEALANT WASHER

ATTACH PURLIN ASSEMBLY ENDS TO ANGLE BRACKETS. TIGHTEN ALL HARDWARE FROM PREVIOUS STEPS.

NOTE: TORX BOLT HOLDING PURLIN BRACKET TO BEAM MAY HAVE TO BE LOOSENED

NOTE: BRACKET HOLE WILL FIT AROUND NUT ZERT AND FLUSH AGAINST PURLIN

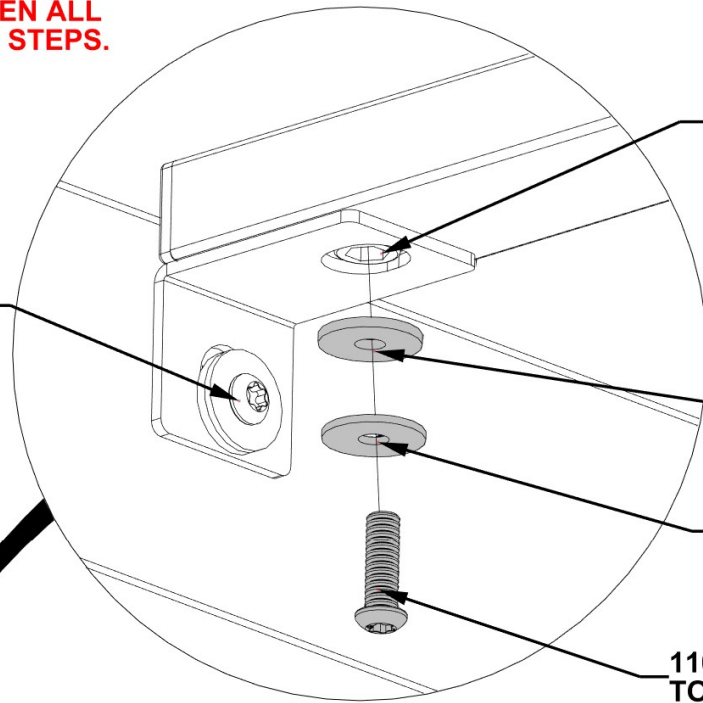

**1054 (x20)
SEALANT WASHER**

**1053 (x20)
STEEL WASHER 6x20**

**1101 (x20)
TORX PAN HEAD 1/4-20x3/4"**

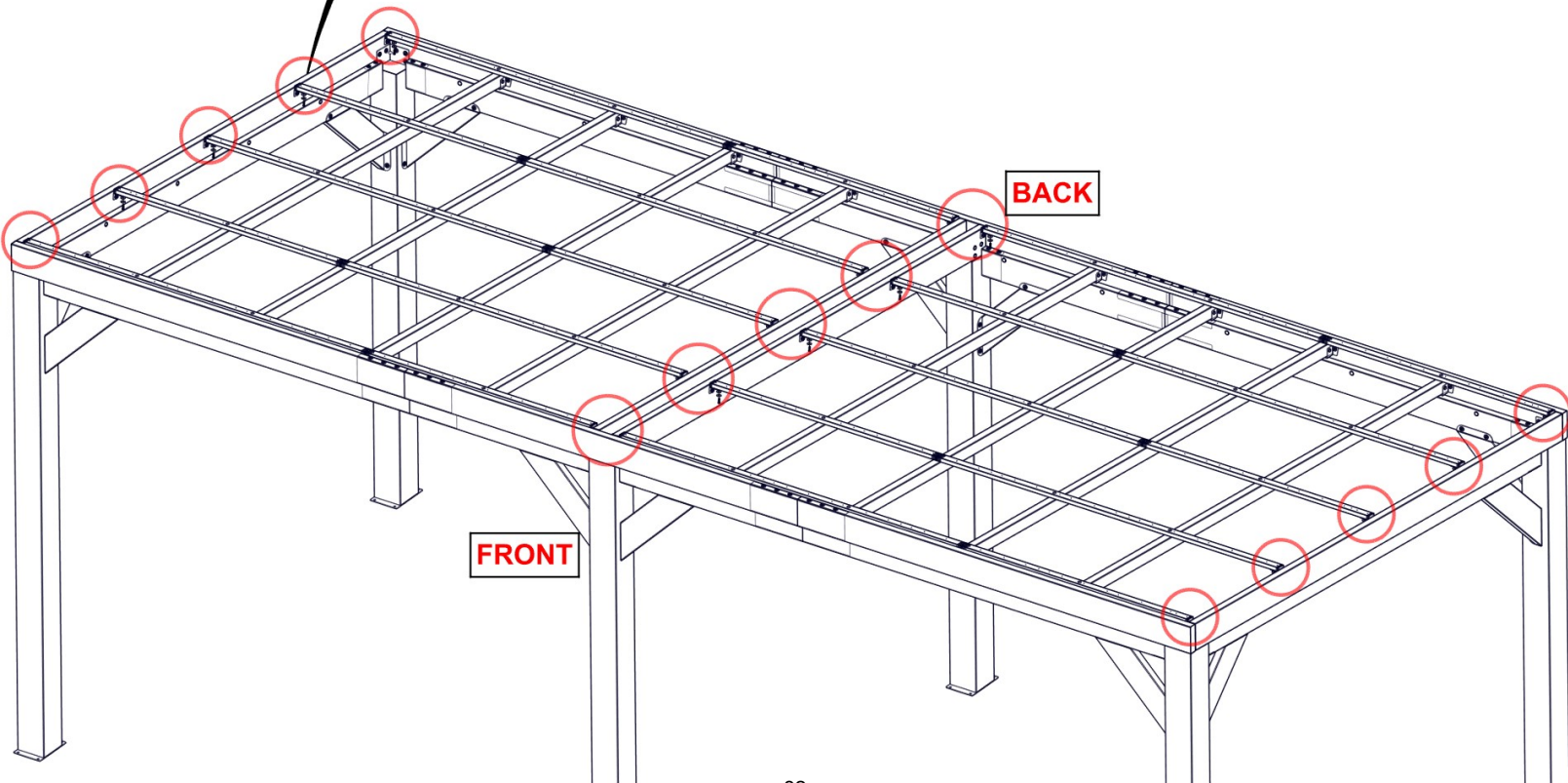

STEP 60 - ROOF ASSEMBLY

Qty	PART NUMBER	Description
20	H101117	SCREW WOODGRIP 10-16x3/4" BLK

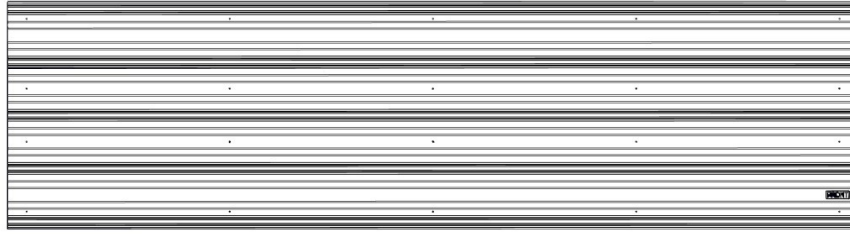

A4M02925 29GA STEEL SHEETING
(x1)

TIPS:
- REMOVE PROTECTIVE FILM.

WARNING: GLOVES ARE RECOMMENDED WHEN HANDLING STEEL ROOF PIECES

STARTING AT THE LEFT SIDE AND WORKING TO THE RIGHT, LINE UP THE HOLES IN THE ROOF SHEET WITH THE PILOT HOLES IN THE PURLINS.

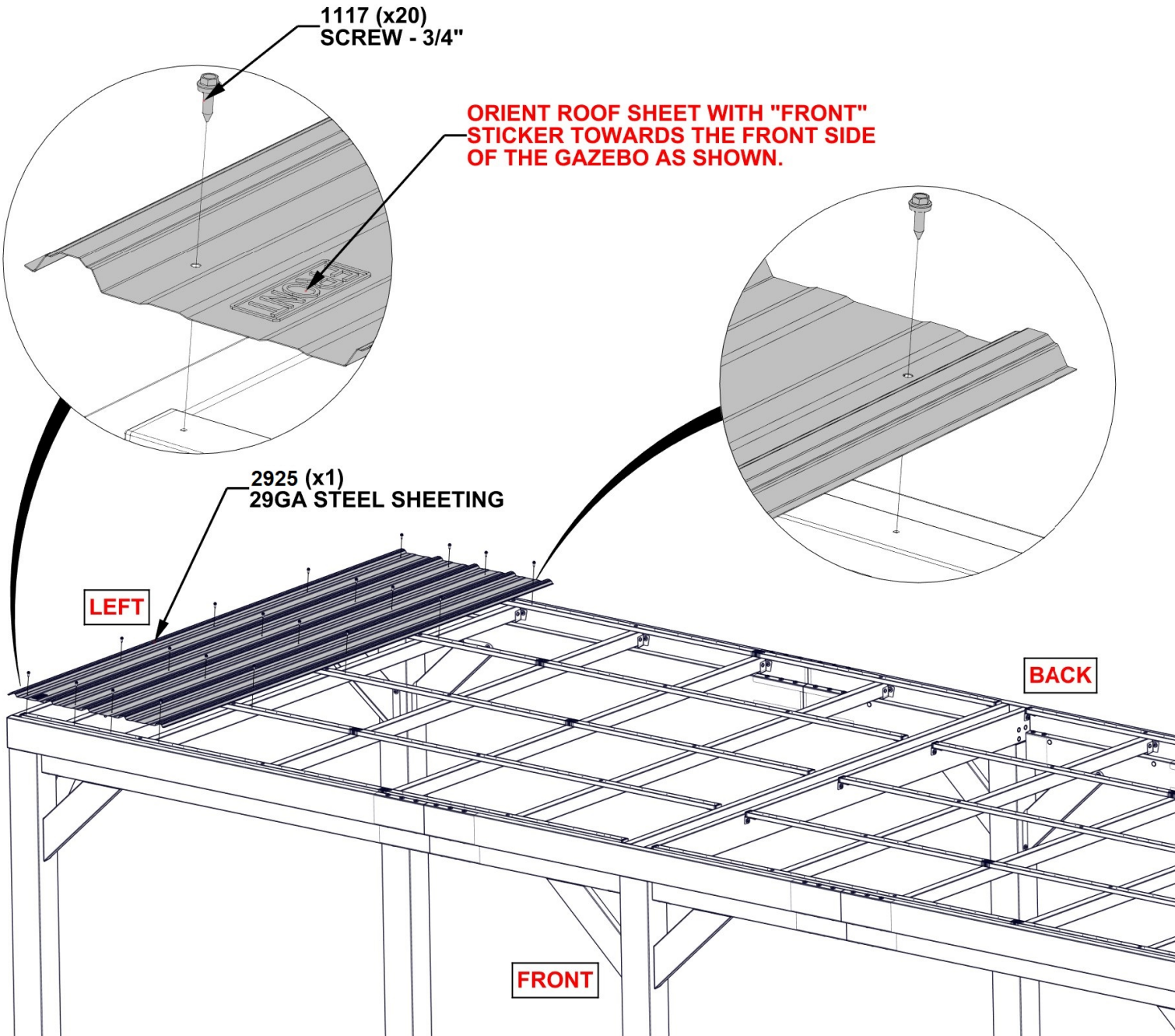

STEP 61 - ROOF ASSEMBLY

Qty	PART NUMBER	Description
60	H101117	SCREW WOODGRIP 10-16x3/4" BLK

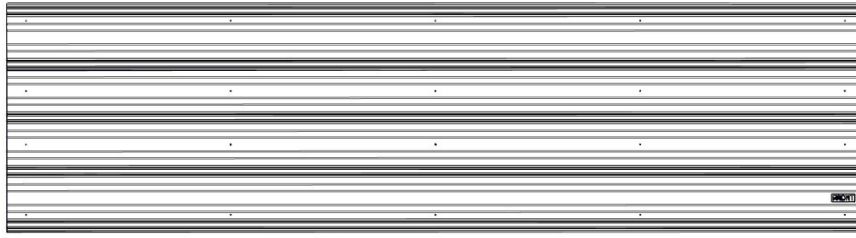

A4M02925 29GA STEEL SHEETING
(x3)

TIPS:
- REMOVE PROTECTIVE FILM.

WARNING: GLOVES ARE RECOMMENDED WHEN HANDLING STEEL ROOF PIECES

STARTING AT THE LEFT SIDE AND WORKING TO THE RIGHT, LINE UP THE HOLES IN THE ROOF SHEETS WITH THE PILOT HOLES IN THE PURLINS.

ATTACH AND FULLY TIGHTEN ALL SCREWS ON EACH ROOF SHEET BEFORE ATTACHING THE NEXT ONE. THIS MAKES IT POSSIBLE TO REACH ALL THE SCREWS WITHOUT GETTING ON THE ROOF.

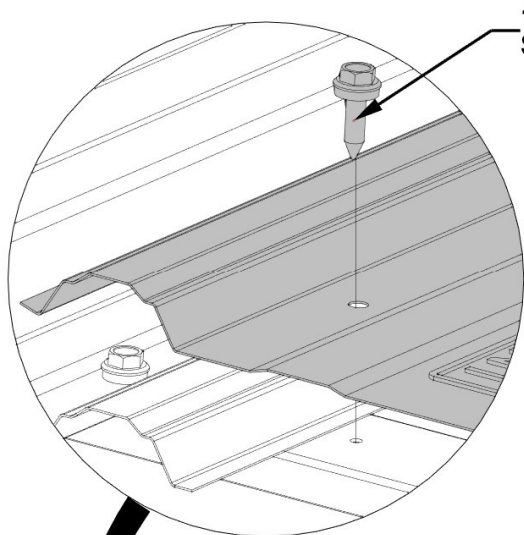

1117 (x60)
SCREW - 3/4"

NOTE: SHEETS OVERLAP BY ONE RIB

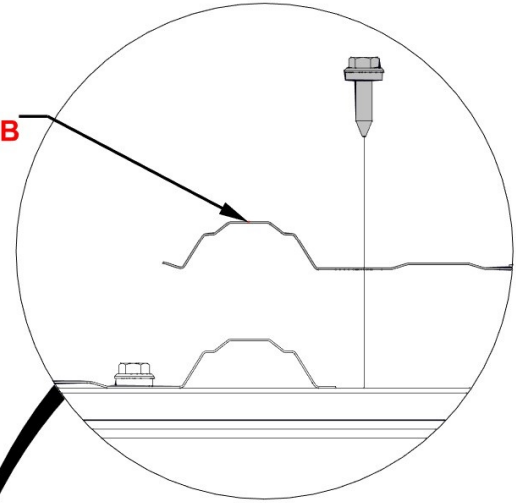

ORIENT ROOF SHEET WITH "FRONT" STICKER TOWARDS THE FRONT SIDE OF THE GAZEBO AS SHOWN.

2925 (x3)
29GA STEEL SHEETING

LEFT

BACK

FRONT

STEP 62 - ROOF ASSEMBLY

Qty	PART NUMBER	Description
10	H101117	SCREW WOODGRIP 10-16x3/4" BLK

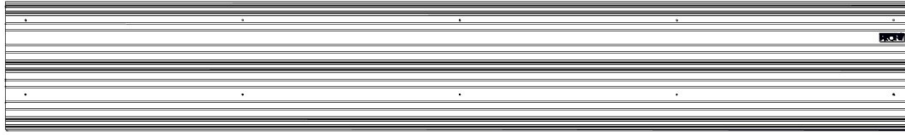

A4M02926 29 GA STEEL SHEETING
(x1)

TIPS:
- REMOVE PROTECTIVE FILM.

WARNING: GLOVES ARE RECOMMENDED WHEN HANDLING STEEL ROOF PIECES

STARTING AT THE LEFT SIDE AND WORKING TO THE RIGHT, LINE UP THE HOLES IN THE ROOF SHEETS WITH THE PILOT HOLES IN THE PURLINS.

NOTE: SHEETS OVERLAP BY ONE RIB

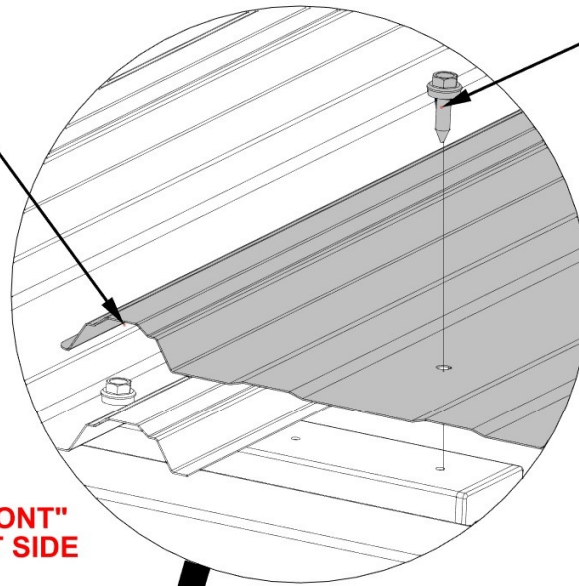

1117 (x10)
SCREW - 3/4"

ORIENT ROOF SHEET WITH "FRONT" STICKER TOWARDS THE FRONT SIDE OF THE GAZEBO AS SHOWN.

2926 (x1)
29 GA STEEL SHEETING

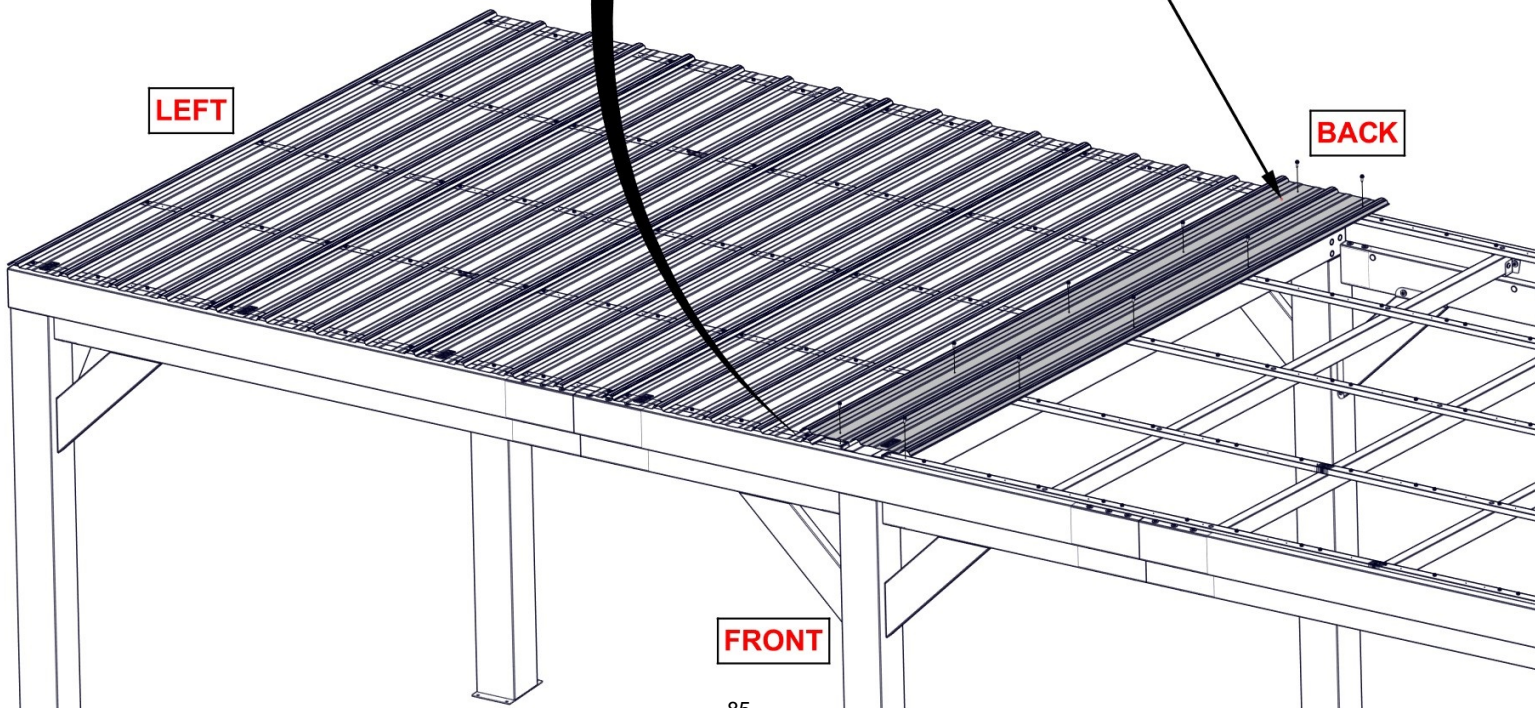

STEP 63 - ROOF ASSEMBLY

Qty	PART NUMBER	Description
80	H101117	SCREW WOODGRIP 10-16x3/4" BLK

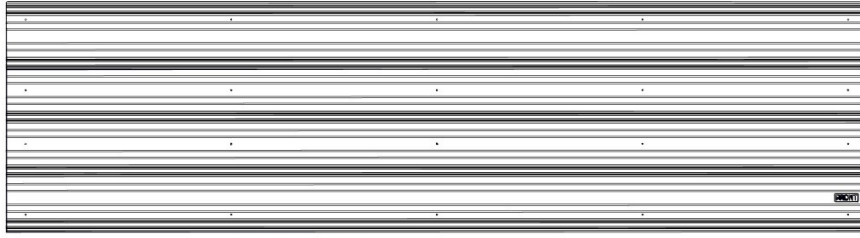

A4M02925 29GA STEEL SHEETING
(x4)

TIPS:
- REMOVE PROTECTIVE FILM.

**WARNING: GLOVES ARE RECOMMENDED
WHEN HANDLING STEEL ROOF PIECES**

INSTALL THE REMAINING 4 SHEETS IN THE SAME WAY AS THE PREVIOUS STEPS.

**ENSURE "FRONT" STICKER IS ORIENTED TO THE FRONT OF THE GAZEBO.
LINE UP HOLES IN SHEETS WITH THE PILOT HOLES IN THE PURLINS.**

**ATTACH AND FULLY TIGHTEN ALL SCREWS ON EACH ROOF SHEET
BEFORE ATTACHING THE NEXT ONE. THIS MAKES IT POSSIBLE TO
REACH ALL THE SCREWS WITHOUT GETTING ON THE ROOF.**

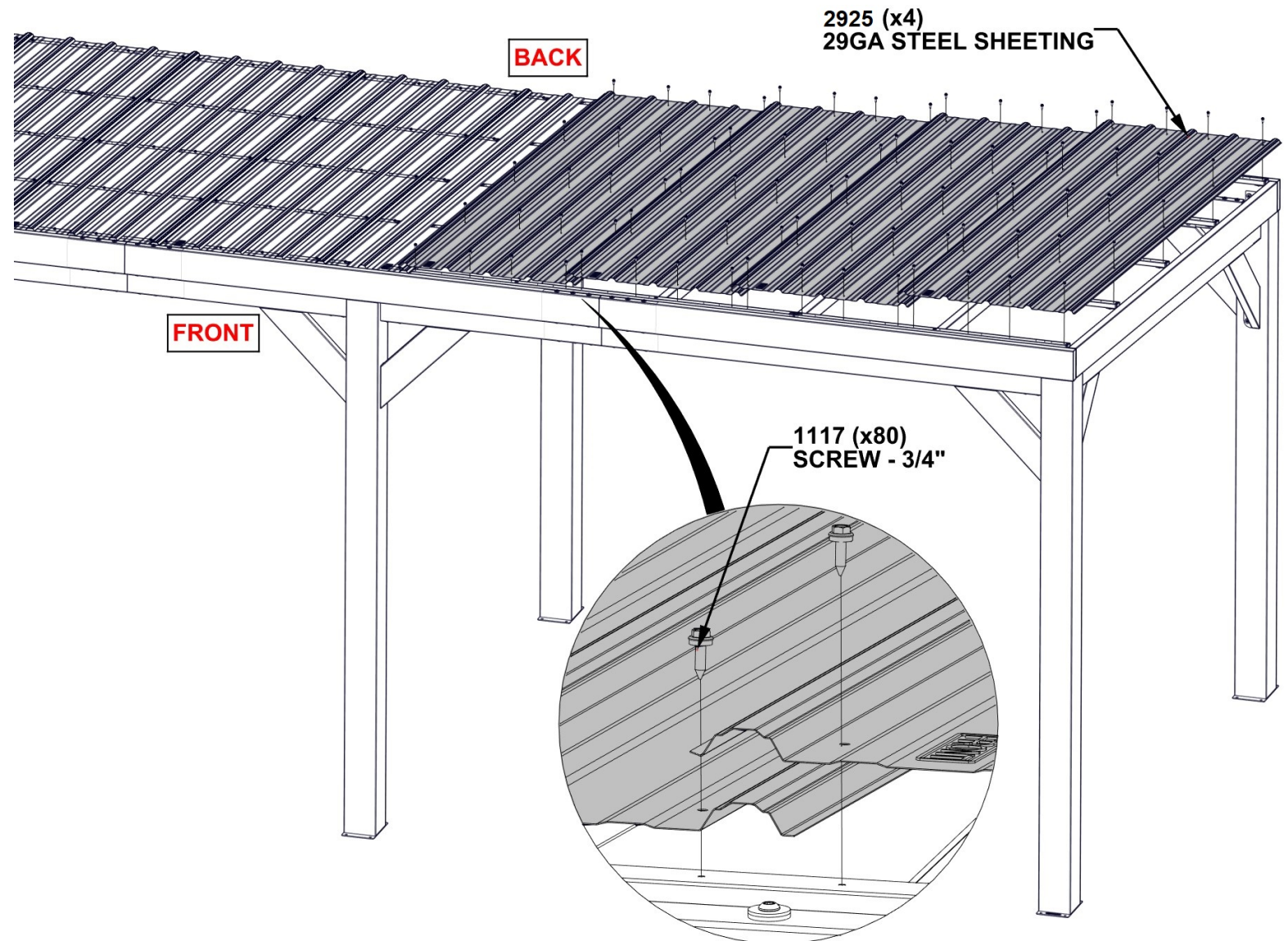

STEP 64 - ROOF ASSEMBLY

Qty	PART NUMBER	Description
32	H101116	SCREW SELF TAPPING 1/4 x 1

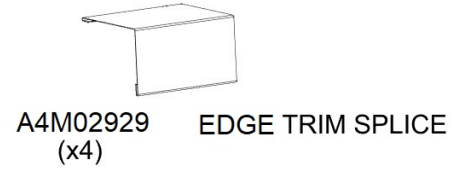
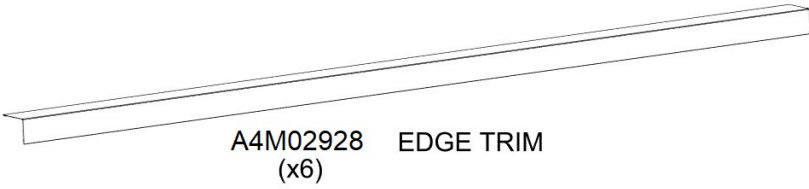

- TIPS:
- REMOVE PROTECTIVE BLUE FILM.
 - DUE TO MULTIPLE LAYERS OF METAL ON THE EDGE TRIM, IT IS RECOMMENDED THAT A 1/8" DRILL BIT BE USED TO CREATE STARTER HOLES.

WARNING: GLOVES ARE RECOMMENDED WHEN HANDLING STEEL ROOF PIECES.

SCREWS GO THROUGH FRONT/BACK TRIM INTO THE TOP OF THE RIBS IN THE APPROXIMATE LOCATIONS SHOWN.

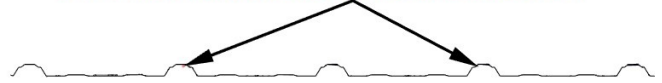

NOTE: LONG SIDE OF TRIM WILL BE ON TOP OF SHEETS

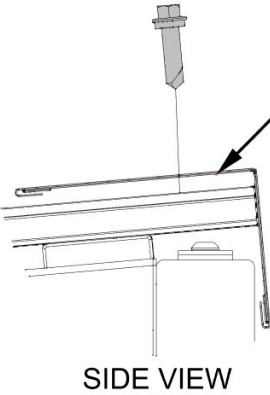

EDGE OF TRIM WILL BE RECESSED FROM EDGE

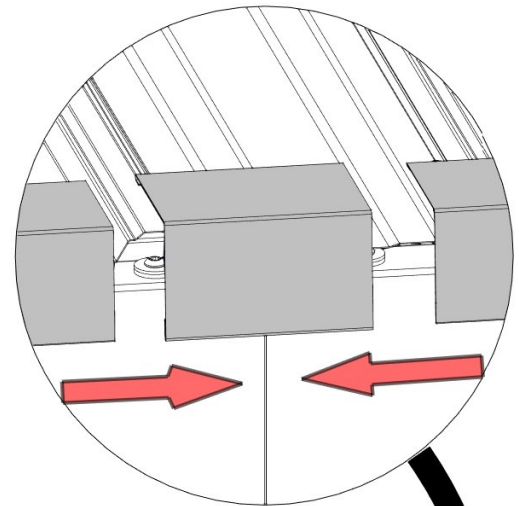
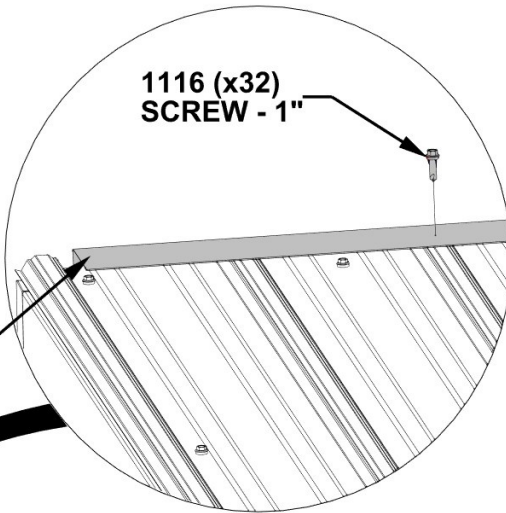

CENTER TRIM SPLICE WITH SEAM IN BETWEEN EACH BEAM, THEN SLIDE IN EDGE TRIM.

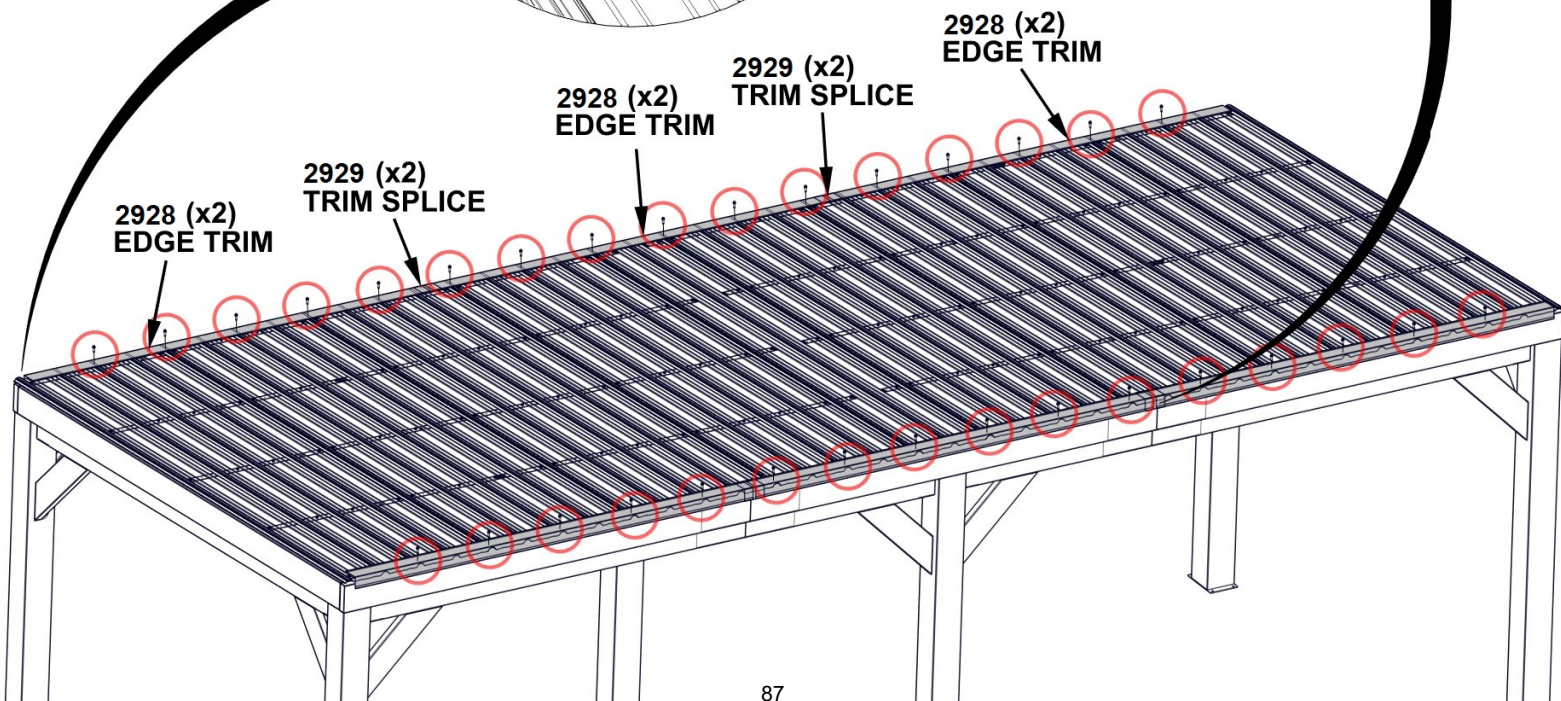

STEP 65A - ROOF ASSEMBLY

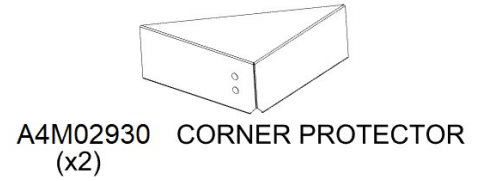
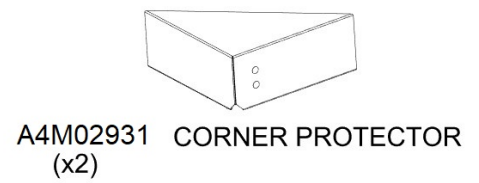
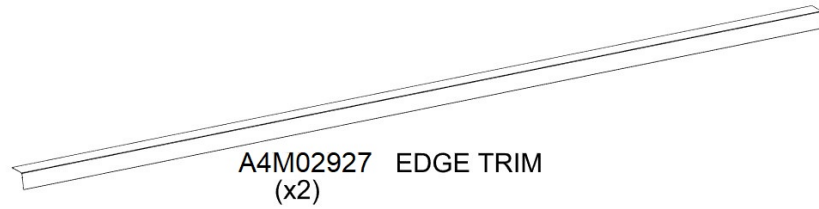

- TIPS:
- REMOVE PROTECTIVE BLUE FILM.
 - DUE TO MULTIPLE LAYERS OF METAL ON THE EDGE TRIM, IT IS RECOMMENDED THAT A 1/8" DRILL BIT BE USED TO CREATE STARTER HOLES.

WARNING: GLOVES ARE RECOMMENDED WHEN HANDLING STEEL ROOF PIECES.

SLIDE THE SIDE EDGE TRIM AND CORNER PROTECTORS ONTO THE FRONT AND BACK TRIM. THE CORNER PROTECTOR WILL SLIDE ONTO THE FRONT AND BACK TRIM IN THE SAME WAY THE FRONT TRIM WAS SLID INTO THE SPLICE.

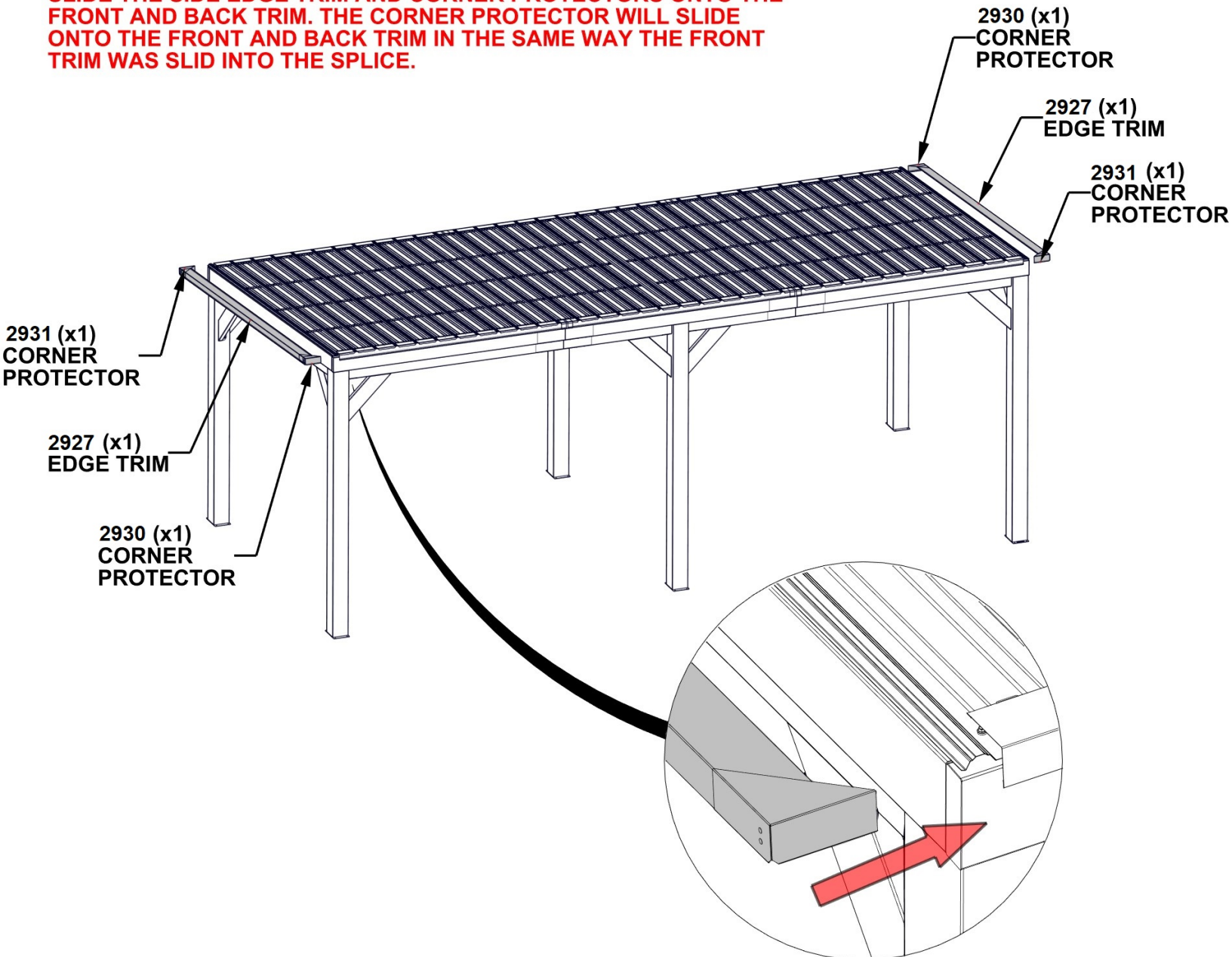

STEP 65B - ROOF ASSEMBLY

Qty	PART NUMBER	Description
18	H101116	SCREW SELF TAPPING 1/4 x 1

TIPS:

- REMOVE PROTECTIVE BLUE FILM.
- DUE TO MULTIPLE LAYERS OF METAL ON THE EDGE TRIM, IT IS RECOMMENDED THAT A 1/8" DRILL BIT BE USED TO CREATE STARTER HOLES.

WARNING: GLOVES ARE RECOMMENDED WHEN HANDLING STEEL ROOF PIECES.

ENSURE THAT SCREWS GO THROUGH THE TOP PORTION OF THE STEEL SHEETING RIB IN THE APPROXIMATE LOCATIONS SHOWN.

ENSURE THAT SCREWS ARE EVENLY SPACED OUT ON THE CORNER PROTECTORS AS SHOWN.

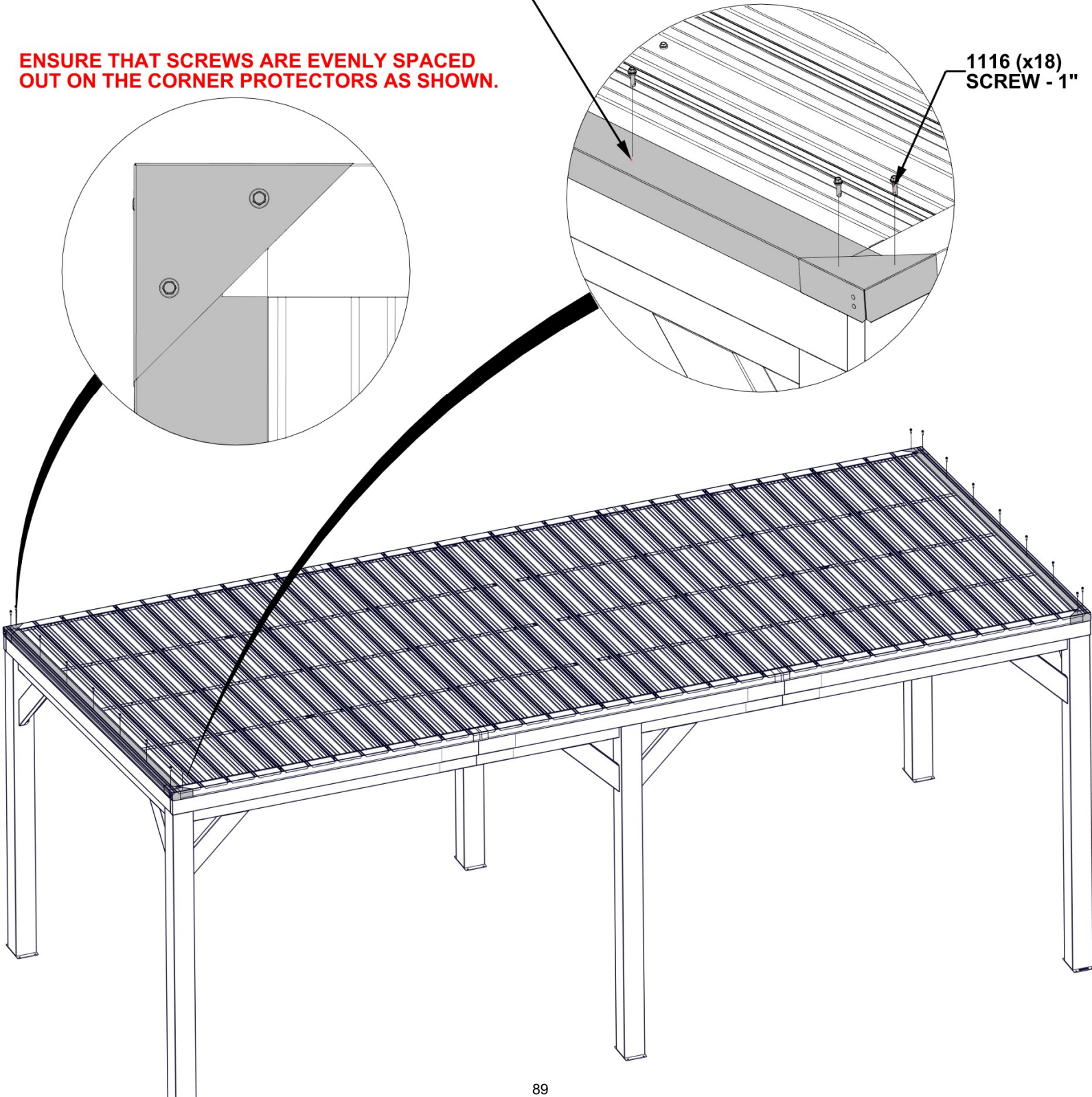

STEP 66 - GAZEBO ANCHORING

Qty	PART NUMBER	Description
24	H100120	CONCRETE ANCHOR
24	H100630	WASHER FLAT 8x19 BLK

MANUFACTURER RECOMMENDS INSTALLATION ON CONCRETE SURFACE OR CONCRETE POST PADS AS SHOWN BELOW.

FOR INSTALLATION ON WOOD DECK, YOU MUST ENSURE THERE IS AMPLE STRUCTURAL SUPPORT UNDER THE DECK. HARDWARE NOT INCLUDED FOR DECK ATTACHMENT.

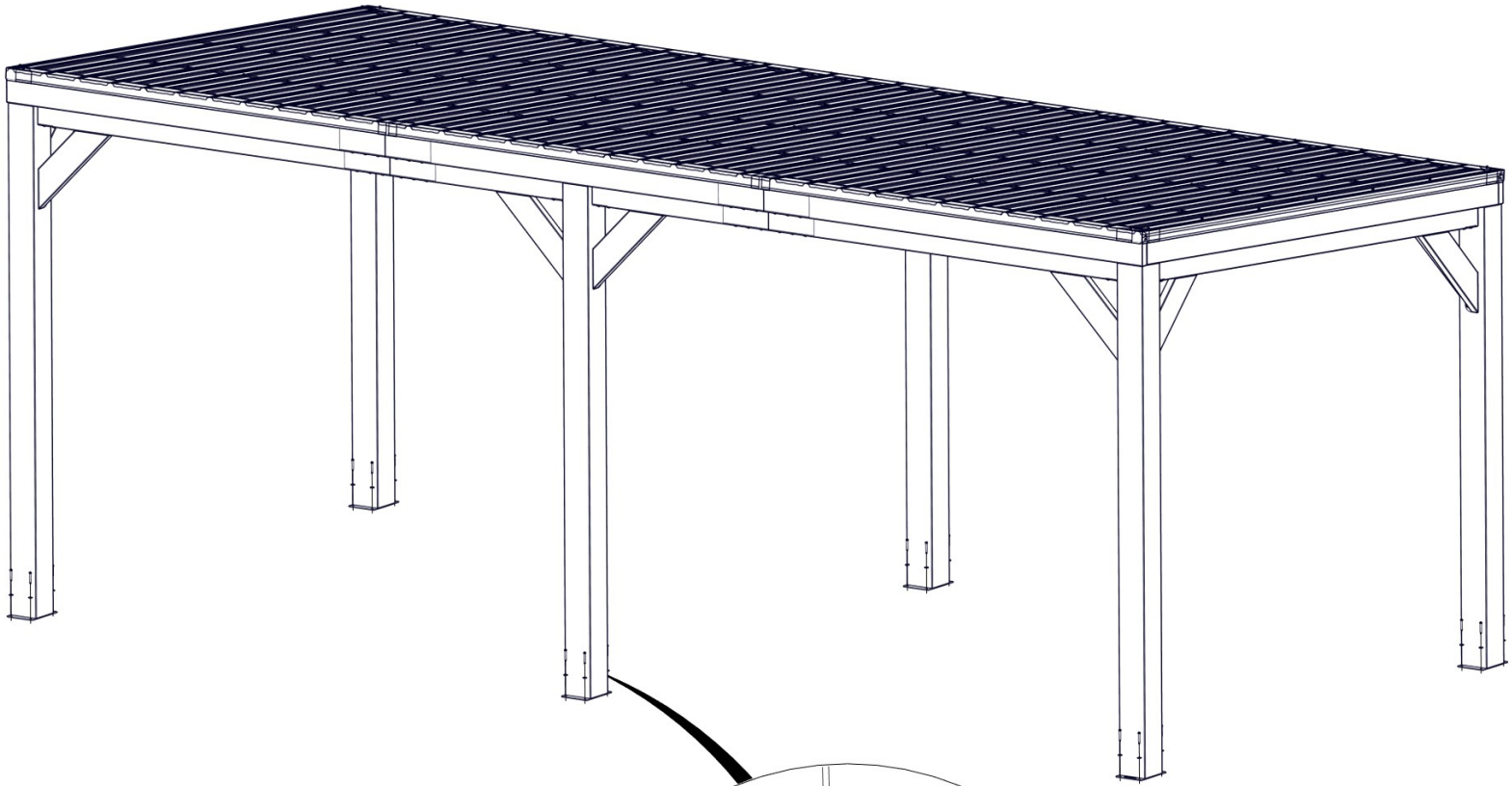

120 (x24)
CONCRETE SCREW-2"

630 (x24)
WASHER - 8x19

**PRE-DRILL HOLES FOR
CONCRETE ANCHORS USING
A 3/16" CONCRETE DRILL BIT.**

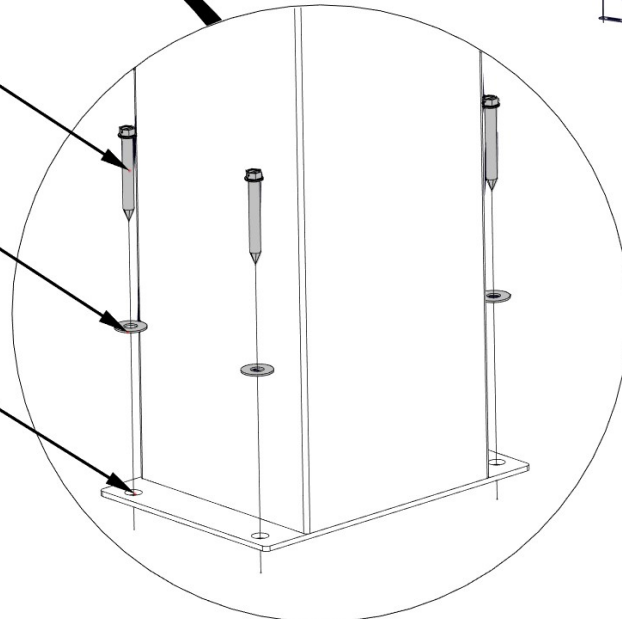

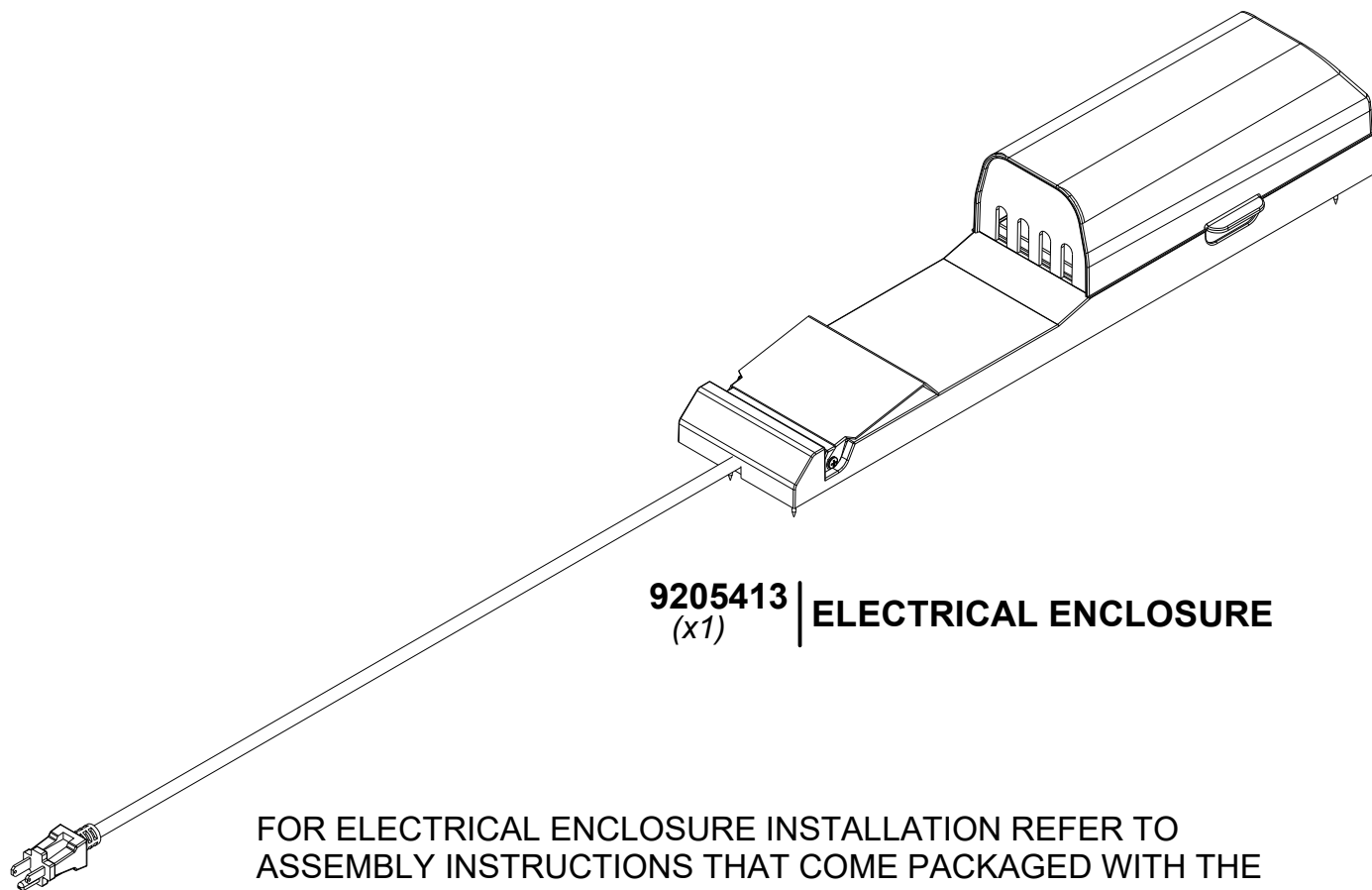

9205413 | **ELECTRICAL ENCLOSURE**
(x1)

FOR ELECTRICAL ENCLOSURE INSTALLATION REFER TO ASSEMBLY INSTRUCTIONS THAT COME PACKAGED WITH THE ELECTRICAL ENCLOSURE KIT. INSTALL ON ANY POST THAT IS DESIRED. FOLLOW DIRECTIONS FOR PROPER INSTALLATION.