



Manufactured by:
Backyard Discovery
3305 Airport Drive, Pittsburg, KS 66762
800-856-4445

*Basepoint Business Centre: Rivermead Drive, Westlea, Swindon SN5 7EX Phone: 0800-118-2476 J.P. Coenstraat 7,
The Bridge, The Hague, 2595 WP, Netherlands Phone: 08005678990*

16x12 BARRINGTON GAZEBO GUTTER KIT

MODEL #: 9240483



Please visit www.backyarddiscovery.com

For the most up to date assembly manual, to register your product, or to order

replacement parts Para obtener instrucciones en español, visite

www.backyarddiscovery.com

OWNER'S MANUAL - PARTS IDENTIFICATION

Hardware Components

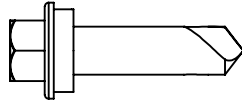

H101480 SCREW SELF TAPPING #9x1 BLK
(x28) 1/4 x 1

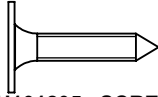

H101205 SCREW PWH BLK
(x16) 8x3/4



H101415 SCREW SELF PIERCING
(x28) #8-15x3/4

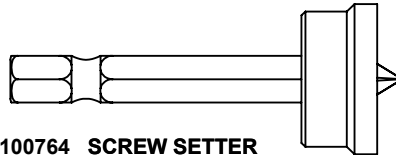

H100764 SCREW SETTER
(x1)

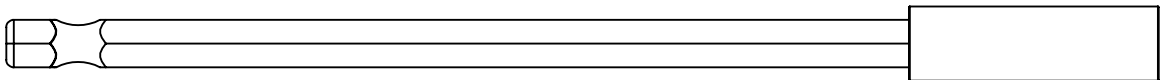

H101278 6" MAGNETIC DRIVER EXTENSION
(x1)



A6P01531 10 OZ SILICONE TUBE
(x1)

OWNER'S MANUAL - PARTS IDENTIFICATION

Hardware Components

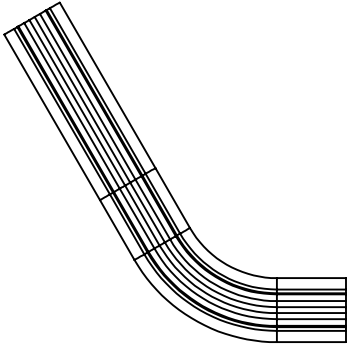

A4M05880 DOWNSPOUT ELBOW - LONG
(x4) 3"x10 5/8"x10 11/16" (76x270x271)

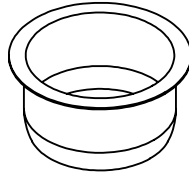

A4M04761 DOWNSPOUT OUTLET
(x4) 1 7/16"x2 7/8" (37x73)

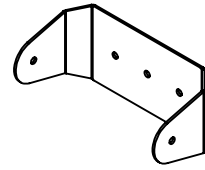

A4M06338 DOWNSPOUT CLIP
(x8) 1 7/16"x1 7/16"x3 1/8" (37x37x79)

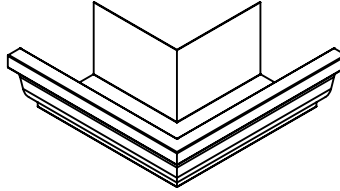

A4M05873 OUTSIDE CORNER MITER
(x4) 3 11/16"x4 7/8"x4 7/8" (94x124x124)

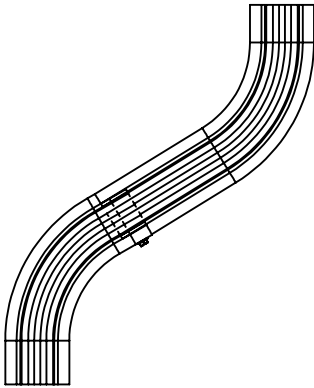

A4M05878 DOWNSPOUT OFFSET - 8IN
(x4) 3"x9 5/8"x12 9/16" (76x244x319)

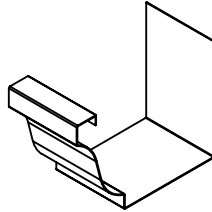

A4M06347 GUTTER SPLICE
(x2) 2 1/2"x3 11/16"x5 1/16" [64x94x129]

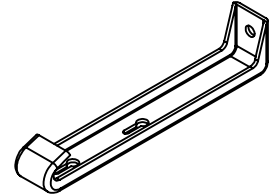

A4M04759 GUTTER HANGER
(x28) 3/4"x1"x4 15/16" (19x25x125)



A4M06340 DOWNSPOUT - 5FT
(x4) 2"x3"x60" (51x76x1524)



A4M06672 GUTTER W/ OUTLET
(x2) 3 5/8"x5"x93 1/2" (92x127x2375)



A4M06673 GUTTER W/ OUTLET
(x2) 3 5/8"x5"x93 1/2" (93x127x2375)

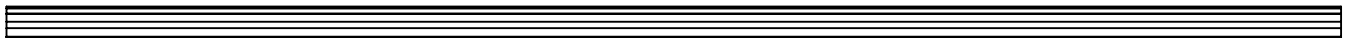

A4M06674 GUTTER
(x2) 3 5/8"x5"x139" (92x127x3531)

PRE-ASSEMBLY STEP 1 - SORTING PARTS

It is critical for ease of assembly that you take the time to sort and organize the parts and hardware.

HARDWARE PARTS:

- We recommend that you have a separate table to organize the hardware.
- Hardware bags are printed with a seven-digit, alpha-numeric part number.
- You can organize your hardware by part number or group by hardware type (e.g. bolts, nuts, etc.).
- During assembly you only need to reference the last four digits of the number.

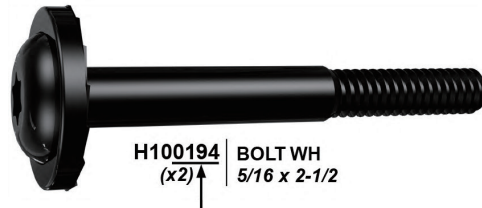

TOOLS REQUIRED:



Cordless Drill or
Electric Drill



Caulk Gun

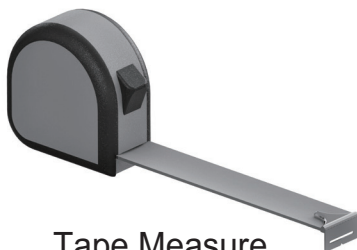

Tape Measure



1/8" Drill Bit

OUTSIDE/INSIDE CORNER MITER PAGE

NOTE:

- AFTER GUTTER KIT HAS BEEN INSTALLED, IT IS CRITICAL TO CAULK CORNER MITER JOINTS TO PREVENT LEAKS.

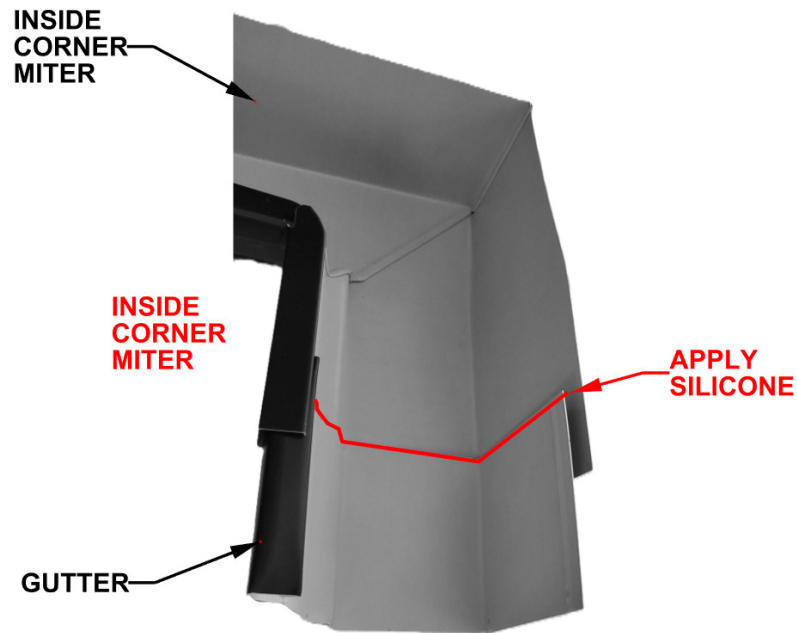
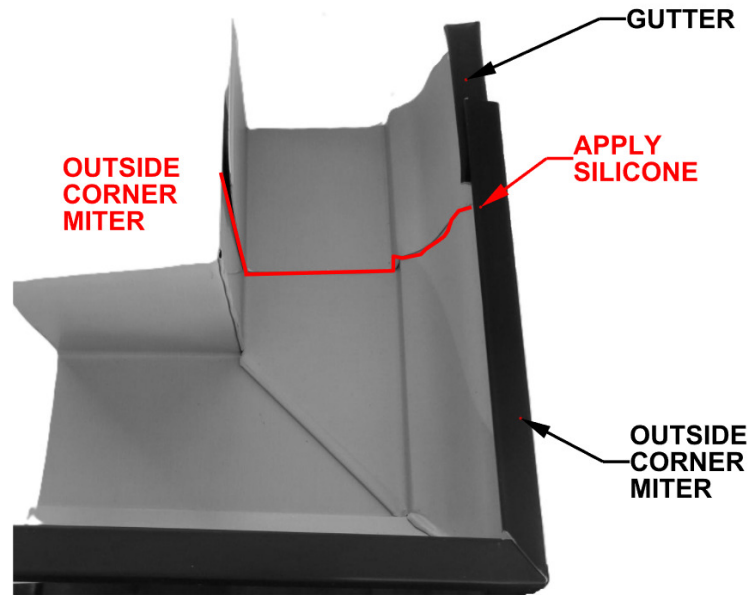

WAIT APPROXIMATELY 45 MINUTES FOR SILICONE TO BECOME TACKY.
AFTER 24 HOURS, SILICONE HAS CURED AND CAN HOLD WATER

GUTTER SPLICE PAGE

- NOTE:**
- APPLY SILICONE TO INSIDE CHANNEL ON BOTH SIDES.
 - ENSURE SILICONE IS EVENLY APPLIED ALONG THE CHANNEL.
 - AFTER GUTTER SPLICE HAS BEEN SLID ONTO GUTTERS AND SILICONE HAS HAD TIME TO CURE, USING HAND PRESSURE ONLY, FOLD THE TOP TAB OVER EDGE OF GUTTER

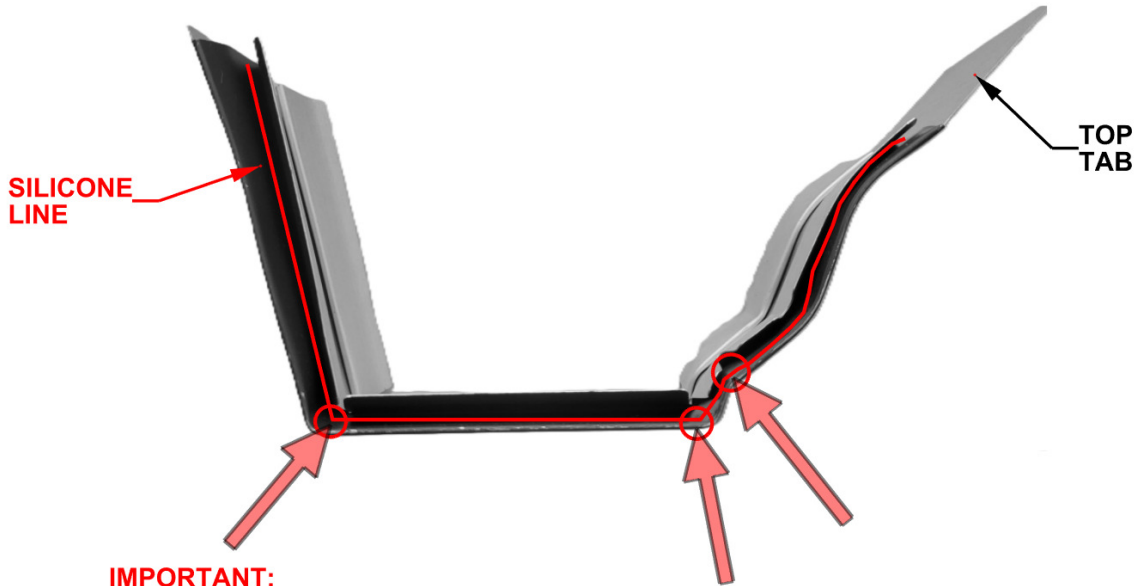

- IMPORTANT:**
- APPLY SILICONE LIBERALLY INTO CORNERS AS INDICATED ABOVE.

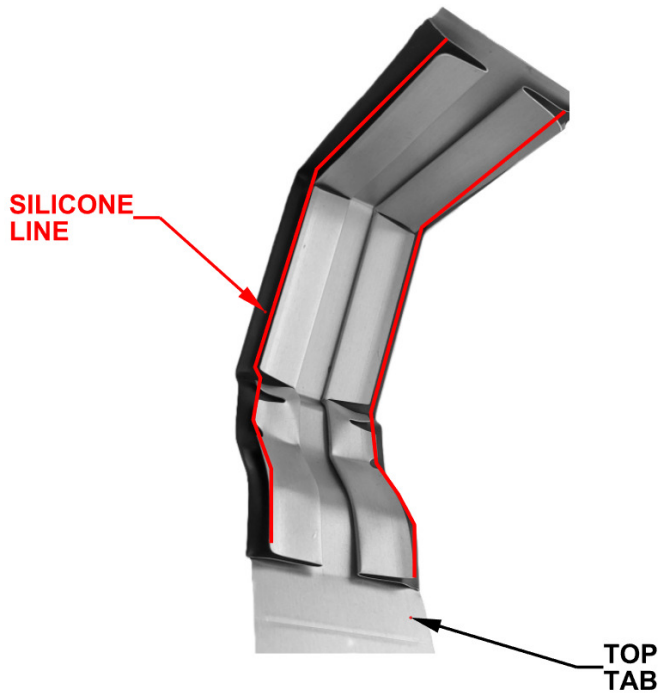

WAIT APPROXIMATELY 45 MINUTES FOR SILICONE TO BECOME TACKY.
AFTER 24 HOURS, SILICONE HAS CURED AND CAN HOLD WATER

OFFSET ORIENTATION

TO ENSURE WATER FLOWS PROPERLY, IT IS IMPORTANT TO ORIENT DOWNSPOUT PIPING CORRECTLY. STARTING AT THE TOP, DOWNSPOUTS MUST FEED INTO THE NEXT SECTION AS SHOWN.

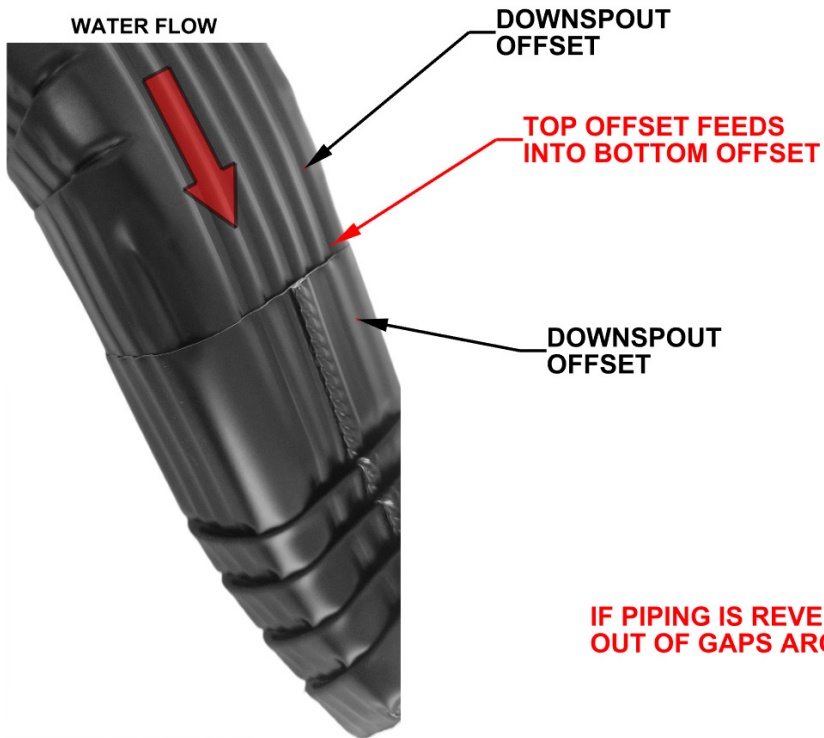

IF PIPING IS REVERSED, WATER WILL RUN OUT OF GAPS AROUND JOINTS

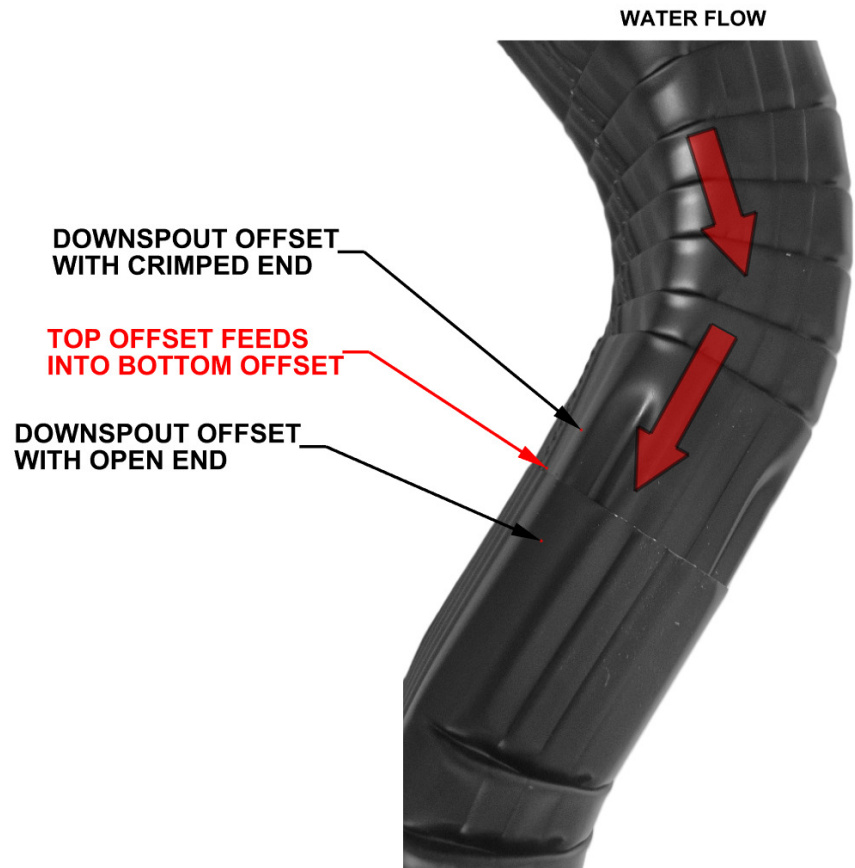

STEP 1 - EDGE TRIM REMOVAL

QTY	PART NUMBER	DESCRIPTION
54	H100759	SCREW SELF TAPPING 1/4x1 BRN

ATTENTION: REMOVE EDGE TRIM FROM ROOF AND SLIDE TRIM AND SPLICES UNDER ROOF SHEETS. DO NOT RE-USE THE CORNER TRIM PIECES.

- REMOVE EDGE TRIM, EDGE TRIM SPLICE AND CORNER TRIM SPLICE BY REMOVING HARDWARE ALONG EDGE.
- RE-ATTACH WITH HARDWARE AND TO RE-USE PREVIOUS HOLES TO AVOID LEAKS.

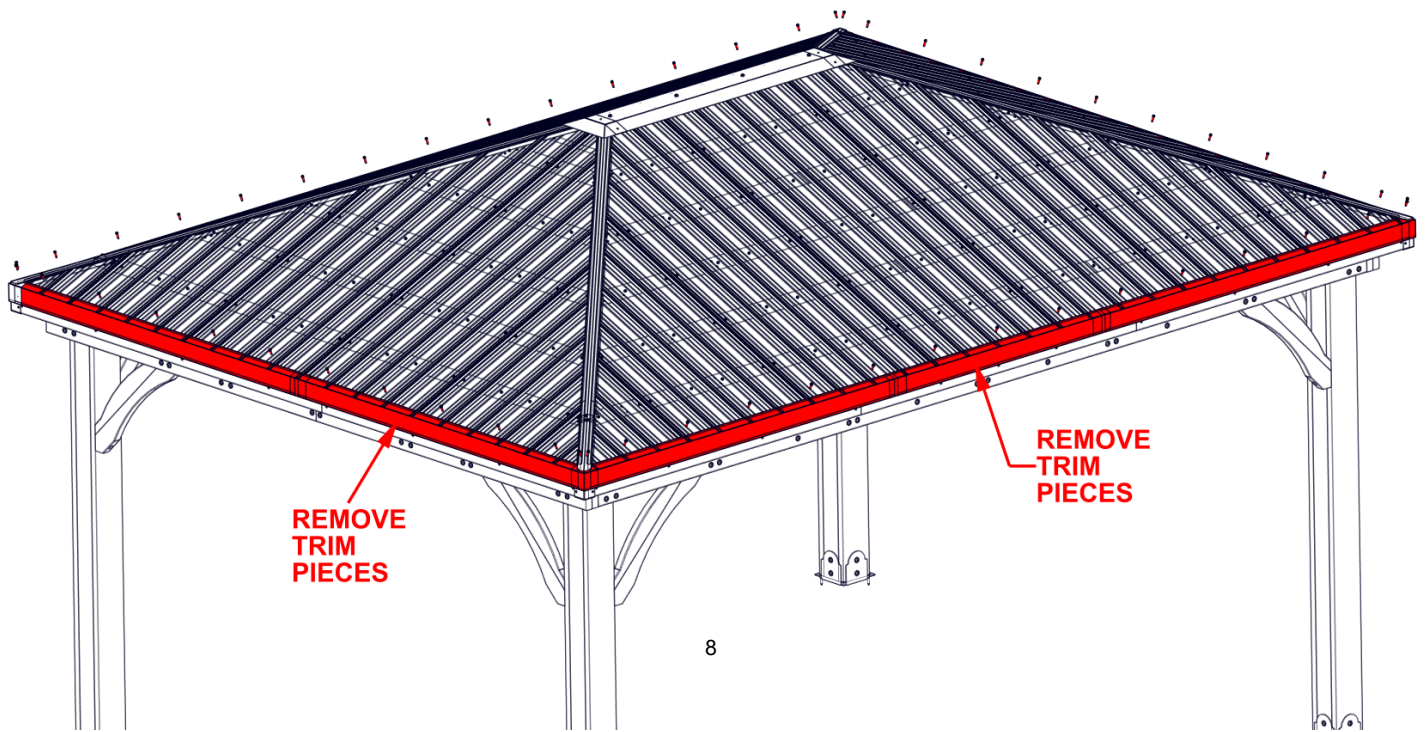
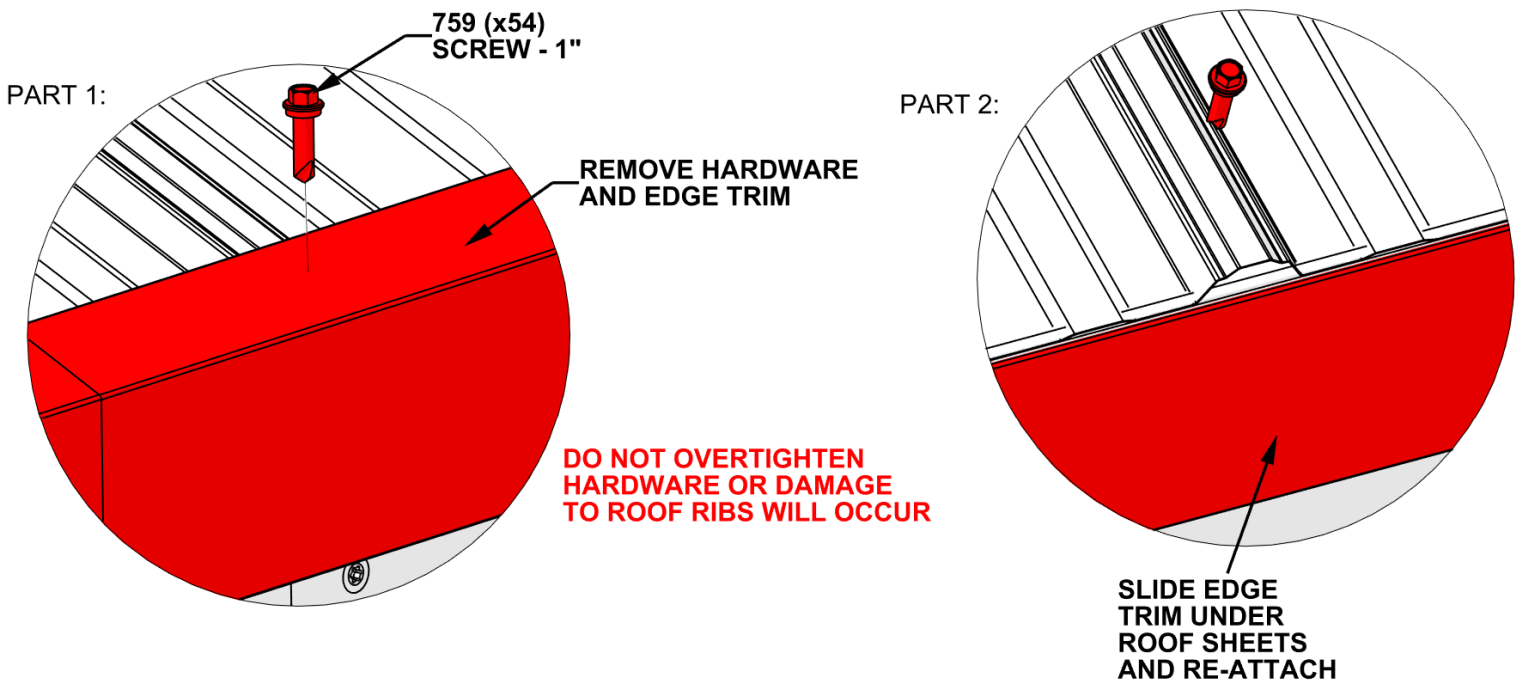

STEP 2 - GUTTER ASSEMBLY

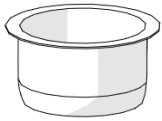

A4M04761 DOWNSPOUT OUTLET
(x4)

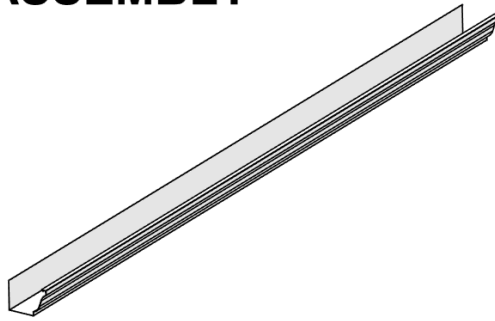

A4M06673 GUTTER W/ OUTLET
(x2)

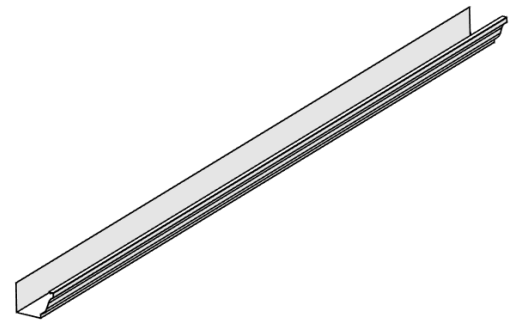

A4M06672 GUTTER W/ OUTLET
(x2)

- APPLY A BEAD OF SILICONE AROUND THE BOTTOM LIP OF THE DOWNSPOUT OUTLET AND PLACE OUTLET INSIDE GUTTER.
- COMPLETE THIS STEP 4 TIMES.

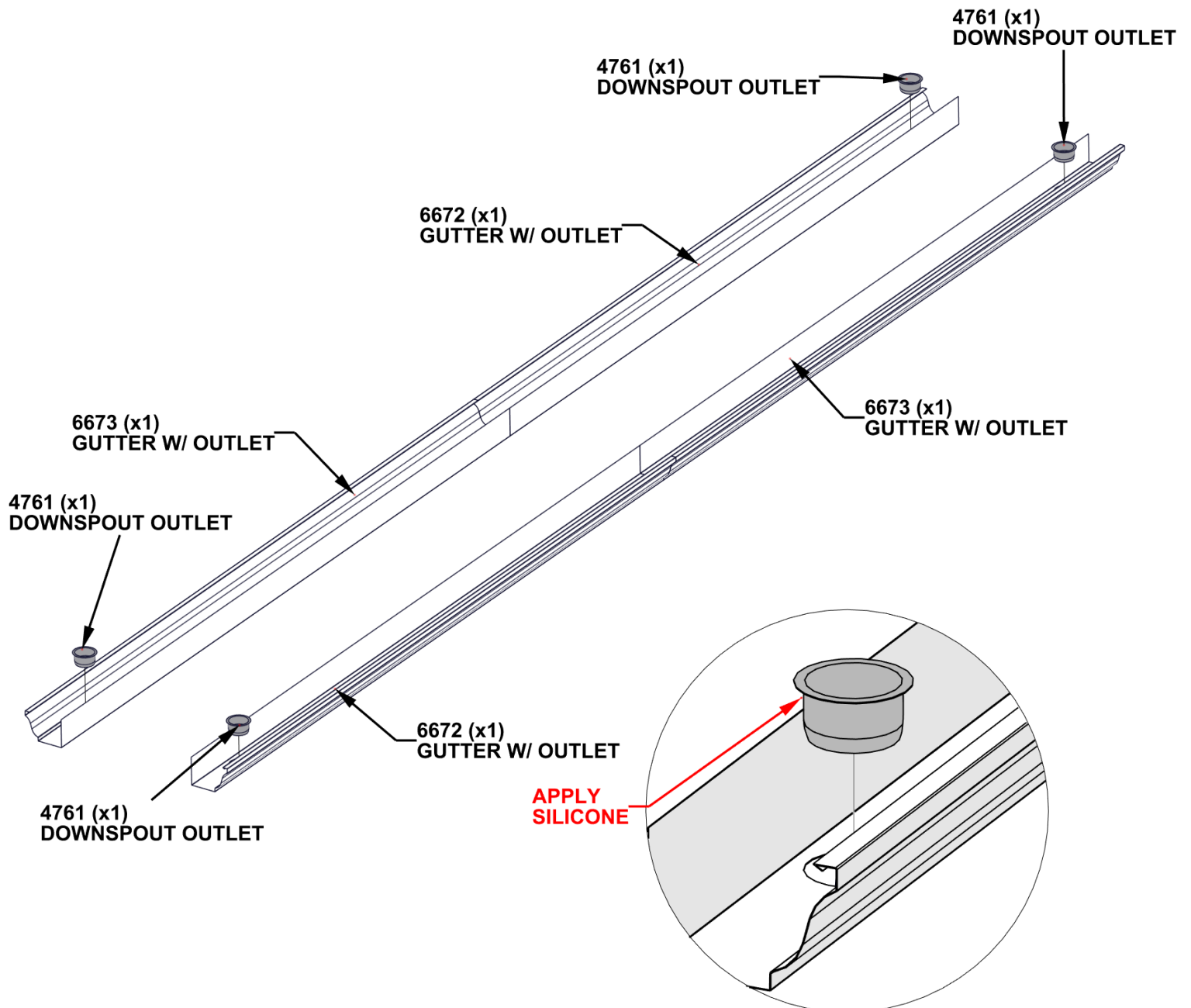

TIP: PRESSURE MAY NEED TO BE APPLIED TO GET OUTLET INTO POSITION. USE A WET FINGER TO FLATTEN SILICONE AFTER INSTALLED.

STEP 3 - GUTTER ASSEMBLY

LAY GUTTERS AROUND GAZEBO TO DETERMINE WHERE GUTTERS WILL BE INSTALLED. DOWNSPOUTS WILL BE INSTALLED ON EACH CORNER.

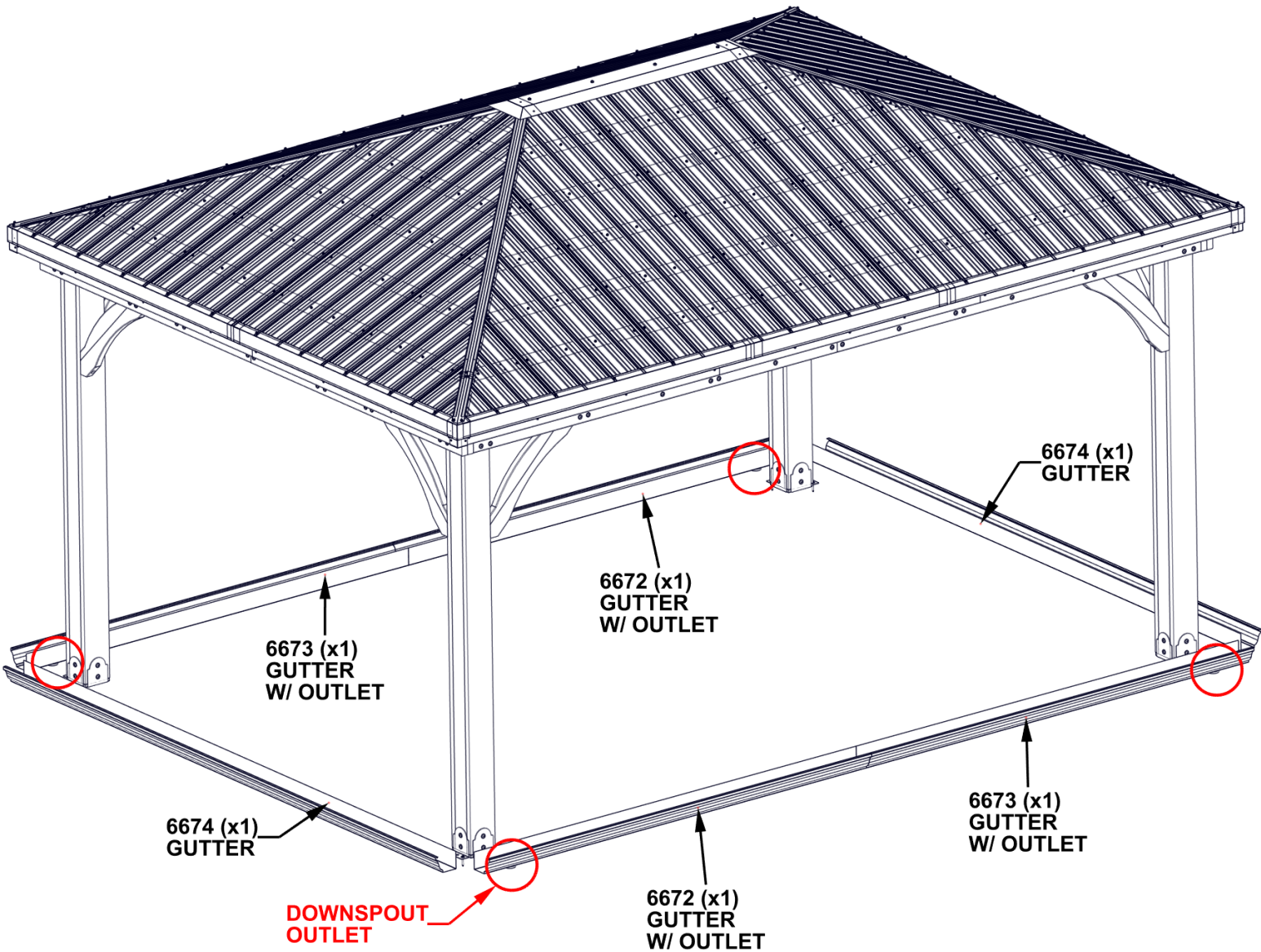

STEP 4 - GUTTER ASSEMBLY

QTY	PART NUMBER	DESCRIPTION
4	H101480	SCREW SELF TAPPING #9-1/4x1

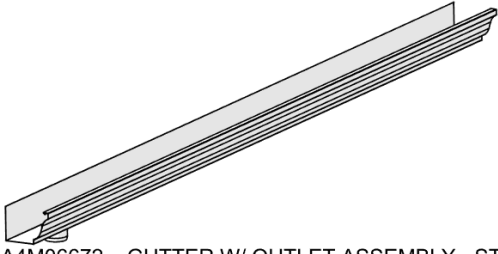

A4M06672 GUTTER W/ OUTLET ASSEMBLY - STEP 2 (x1)



A4M06673 GUTTER W/ OUTLET ASSEMBLY - STEP 2 (x1)

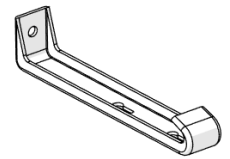

A4M04759 GUTTER HANGER (x4)

- SLIDE GUTTER ASSEMBLY UP UNDER EDGE TRIM AND FLUSH BOTTOM OF GUTTER WITH WOOD BOARD.
- INSTALL GUTTER 1/8" [3mm] FROM METAL BRACKET AS SHOWN.
- INSTALL THE FIRST HANGER APPROXIMATELY 4" [100mm] FROM EDGE OF ROOF.
- INSTALL THE NEXT HANGER BETWEEN ROOF RIBS 7 AND 8 FROM THE FIRST.
- USE A CLAMP TO HOLD THE GUTTER TO WOODEN BEAM FOR ASSISTANCE.
- COMPLETE ON BOTH SIDES.

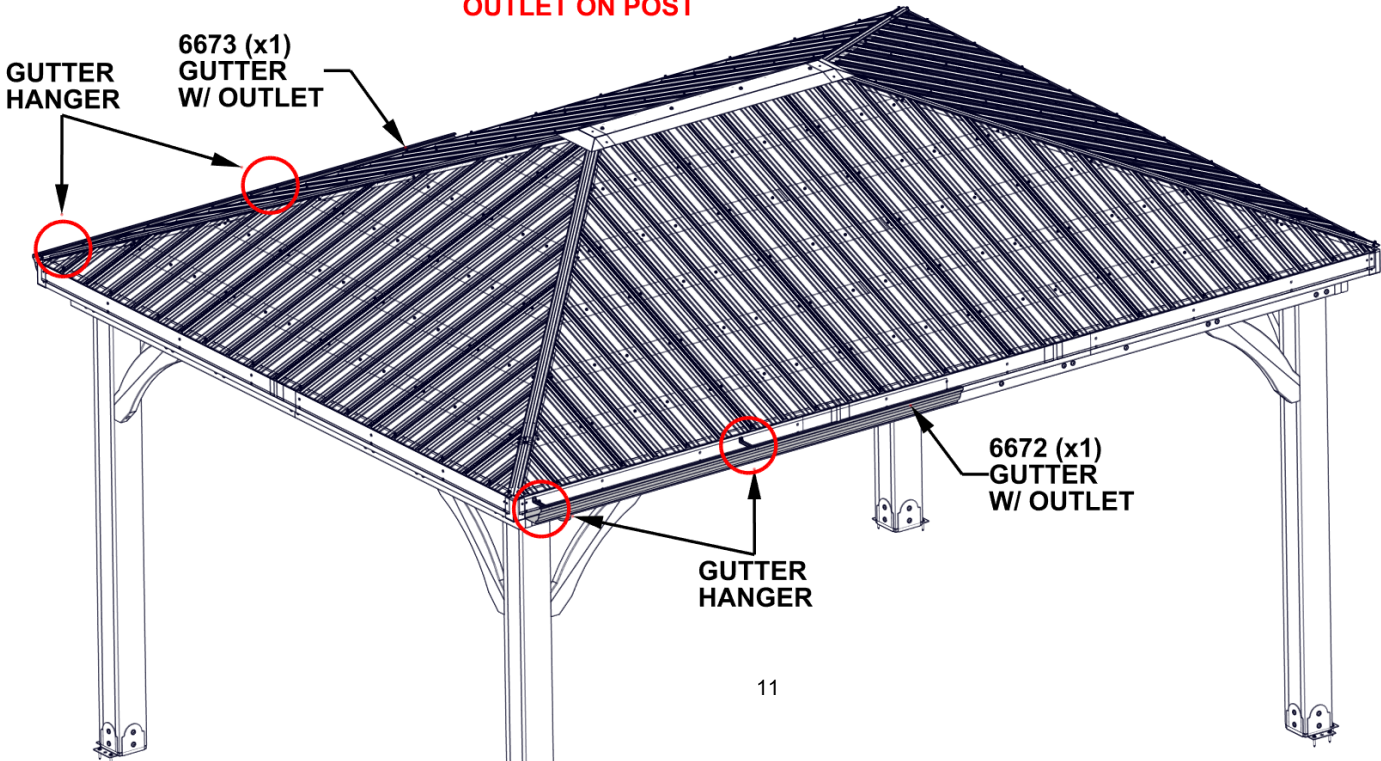
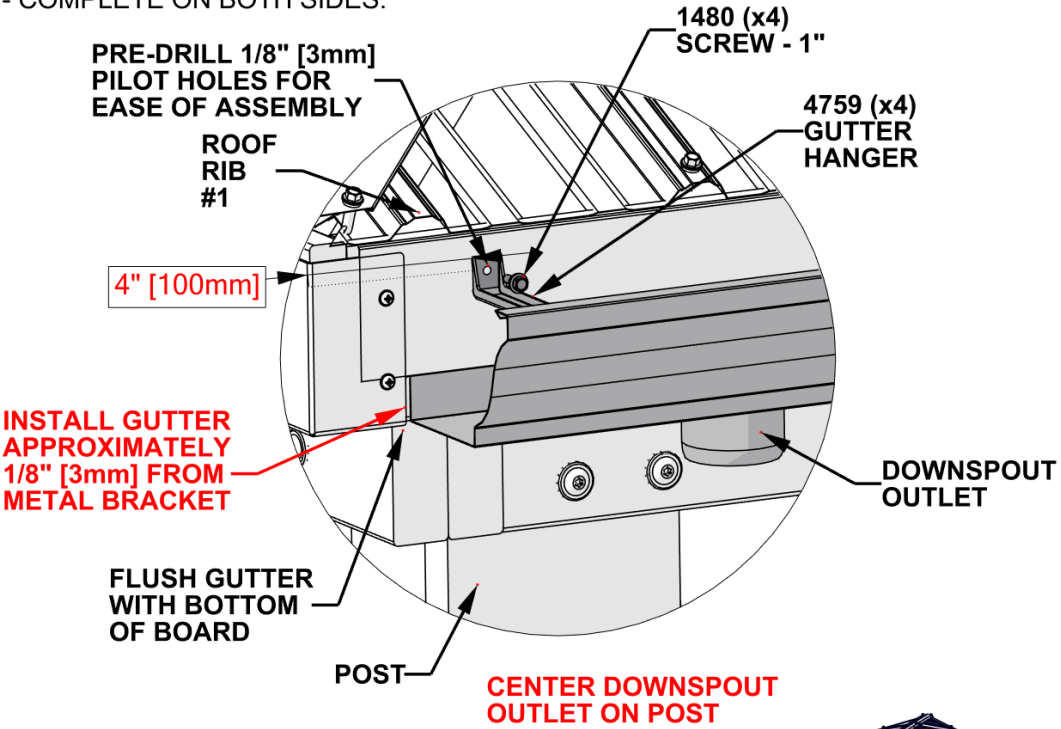

STEP 5 - GUTTER ASSEMBLY

QTY	PART NUMBER	DESCRIPTION
4	H101480	SCREW SELF TAPPING #9-1/4x1

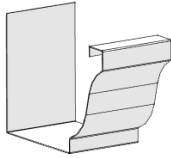
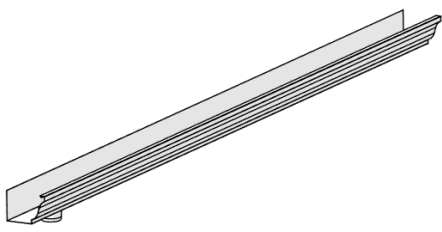

A4M06347 GUTTER SPLICE
(x2)

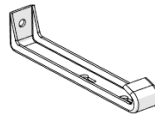

A4M04759 GUTTER HANGER
(x4)

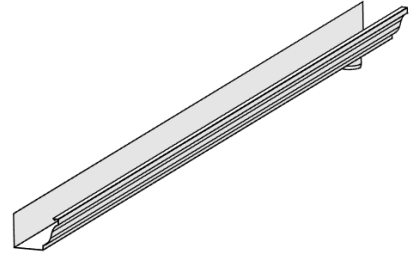

A4M06672 GUTTER W/ OUTLET ASSEMBLY - STEP 2
(x1)

A4M06673 GUTTER W/ OUTLET ASSEMBLY - STEP 2
(x1)

- SLIDE GUTTER ASSEMBLY UP UNDER EDGE TRIM AND FLUSH BOTTOM OF GUTTER WITH WOOD BOARD.
- INSTALL GUTTER 1/8" [3mm] FROM METAL BRACKET AS SHOWN.
- INSTALL THE FIRST HANGER APPROXIMATELY 4" [100mm] FROM EDGE OF ROOF.
- INSTALL THE NEXT HANGER BETWEEN ROOF RIBS 7 AND 8.
- USE A CLAMP TO HOLD THE GUTTER TO WOODEN BEAM FOR ASSISTANCE.
- SEE CAULKING SHEET FOR DETAILS.
- COMPLETE ON BOTH SIDES.

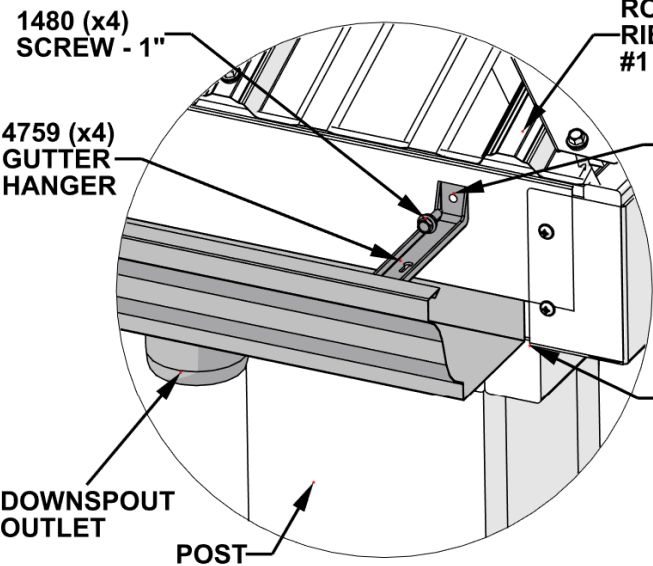

CENTER DOWNSPOUT OUTLET ON POST

APPLY SILICONE TO SPLICE GROOVE BEFORE INSERTING INTO GUTTER

PART 1:

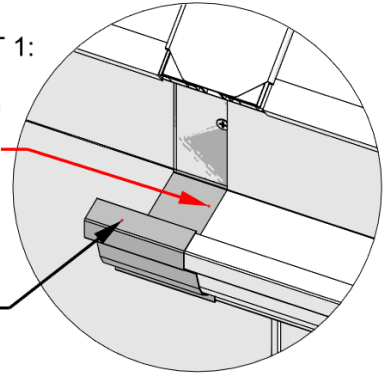

PART 2:

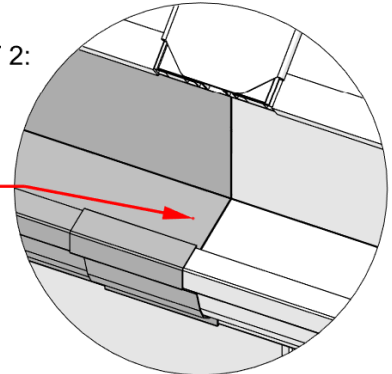

APPLY SILICONE TO SPLICE GROOVE BEFORE INSERTING GUTTER INTO SPLICE

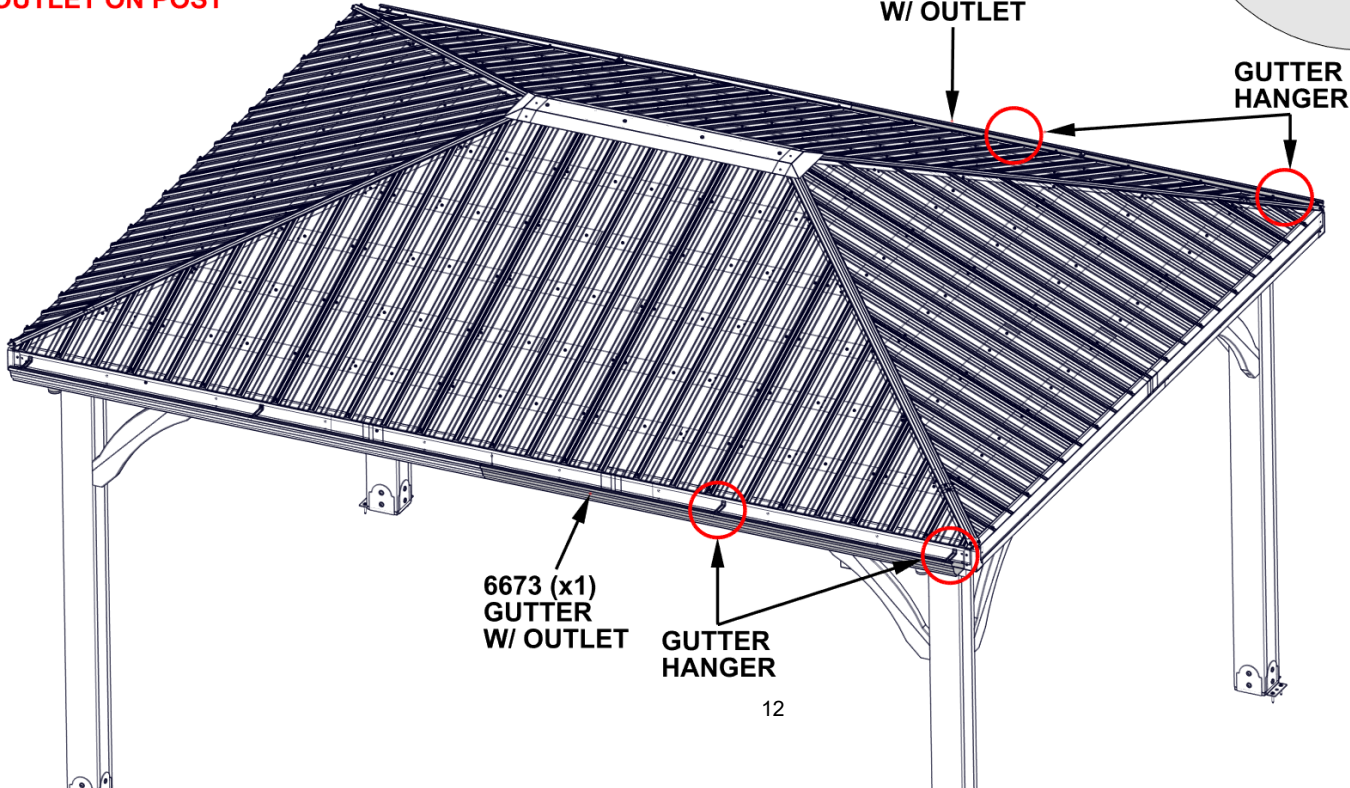

STEP 6 - GUTTER ASSEMBLY

QTY	PART NUMBER	DESCRIPTION
4	H101480	SCREW SELF TAPPING #9-1/4x1

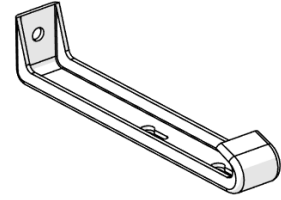
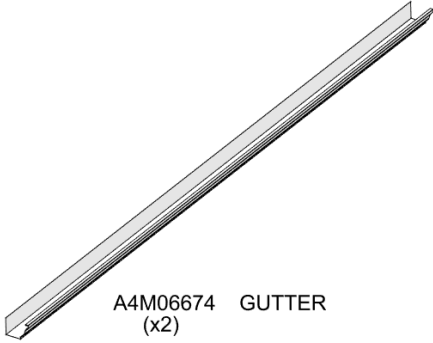

- SLIDE GUTTER UP UNDER EDGE TRIM AND FLUSH BOTTOM OF GUTTER WITH WOOD BEAM.
- CENTER GUTTER BETWEEN METAL BRACKETS ON CORNERS.
- INSTALL THE 2 OUTSIDE HANGERS APPROXIMATELY 4" [100mm] FROM EDGES.
- USE A CLAMP TO HOLD THE GUTTER TO WOODEN BEAM FOR ASSISTANCE.
- COMPLETE ON BOTH SIDES.

PRE-DRILL 1/8" [3mm] PILOT HOLES FOR EASE OF ASSEMBLY

1480 (x4) SCREW - 1"

4759 (x4) GUTTER HANGER

CENTER GUTTER USING METAL BRACKETS ON ENDS, FLUSH GUTTER WITH WOOD BOARD

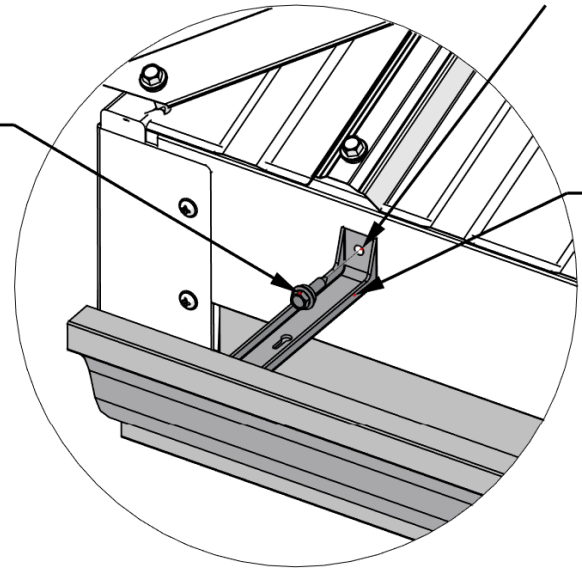

GUTTER HANGER

6674 (x1) GUTTER

GUTTER HANGER

GUTTER HANGER

6674 (x1) GUTTER

GUTTER HANGER

STEP 7 - GUTTER ASSEMBLY

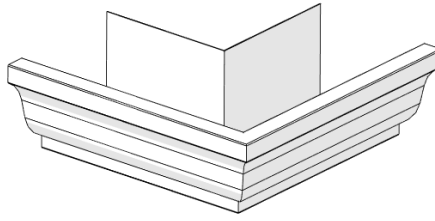

A4M05873 OUTSIDE CORNER MITER
(x4)

- SLIDE OUTSIDE CORNER MITERS OVER GUTTERS AND ENSURE MITER BOX IS SLID UP UNDER DRIP EDGE.
- COMPLETE ON ALL 4 CORNERS.

5873 (x1)
OUTSIDE
CORNER
MITER

5873 (x1)
OUTSIDE
CORNER
MITER

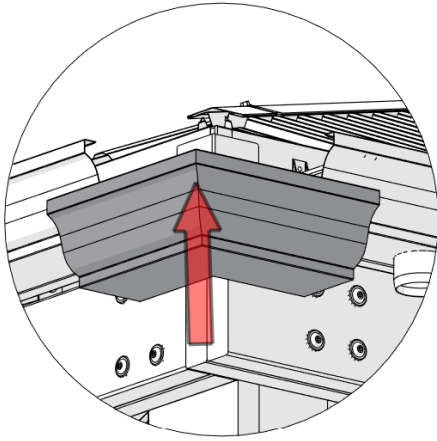

5873 (x1)
OUTSIDE
CORNER
MITER

5873 (x1)
OUTSIDE
CORNER
MITER

STEP 8 - GUTTER ASSEMBLY

QTY	PART NUMBER	DESCRIPTION
8	H101415	SCREW SELF PIERCING #8x1/2 BRN

- ATTACH CORNER MITERS TO GUTTERS USING HARDWARE PROVIDED.
- COMPLETE ON ALL 4 CORNERS.

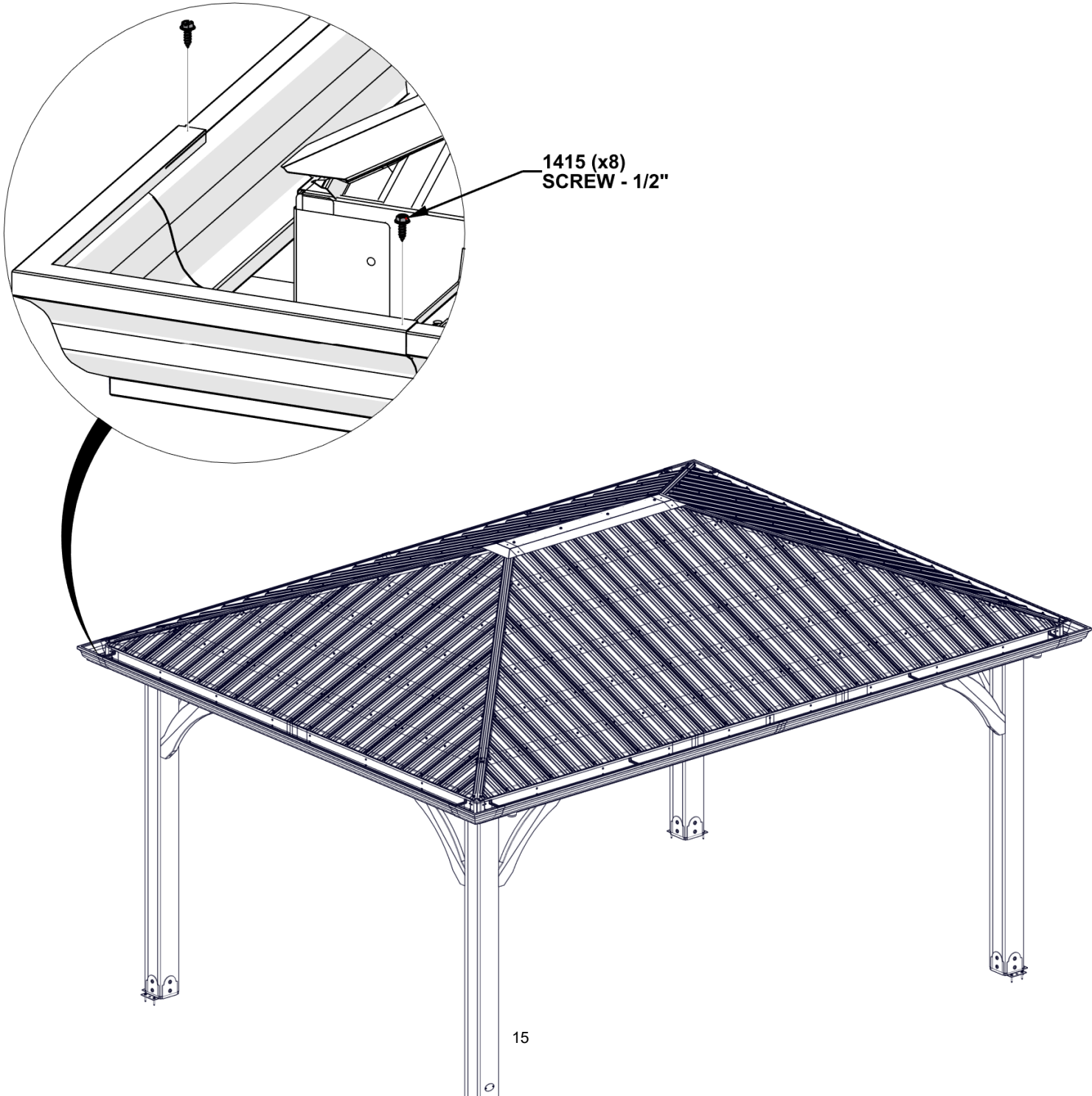

STEP 9 - GUTTER ASSEMBLY

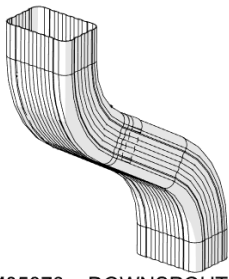

A4M05878 DOWNSPOUT OFFSET - 8"
(x4)

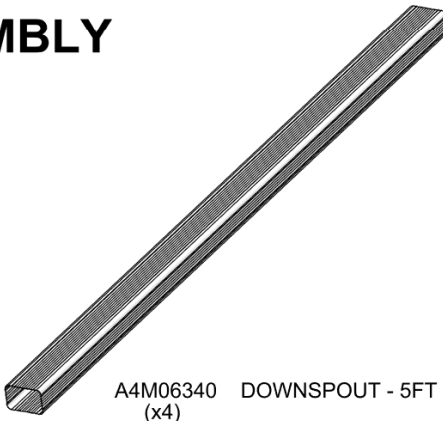

A4M06340 DOWNSPOUT - 5FT
(x4)

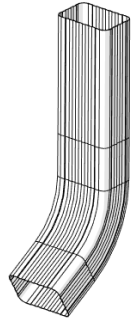

A4M05880 DOWNSPOUT ELBOW - LONG
(x4)

- INSERT TAPERED ENDS INTO LARGER ENDS.
- NOTE ORIENTATION OF DOWNSPOUT OFFSET. SEE DOWNSPOUT OFFSET PAGE FOR DETAIL.
- COMPLETE THIS STEP 4 TIMES.

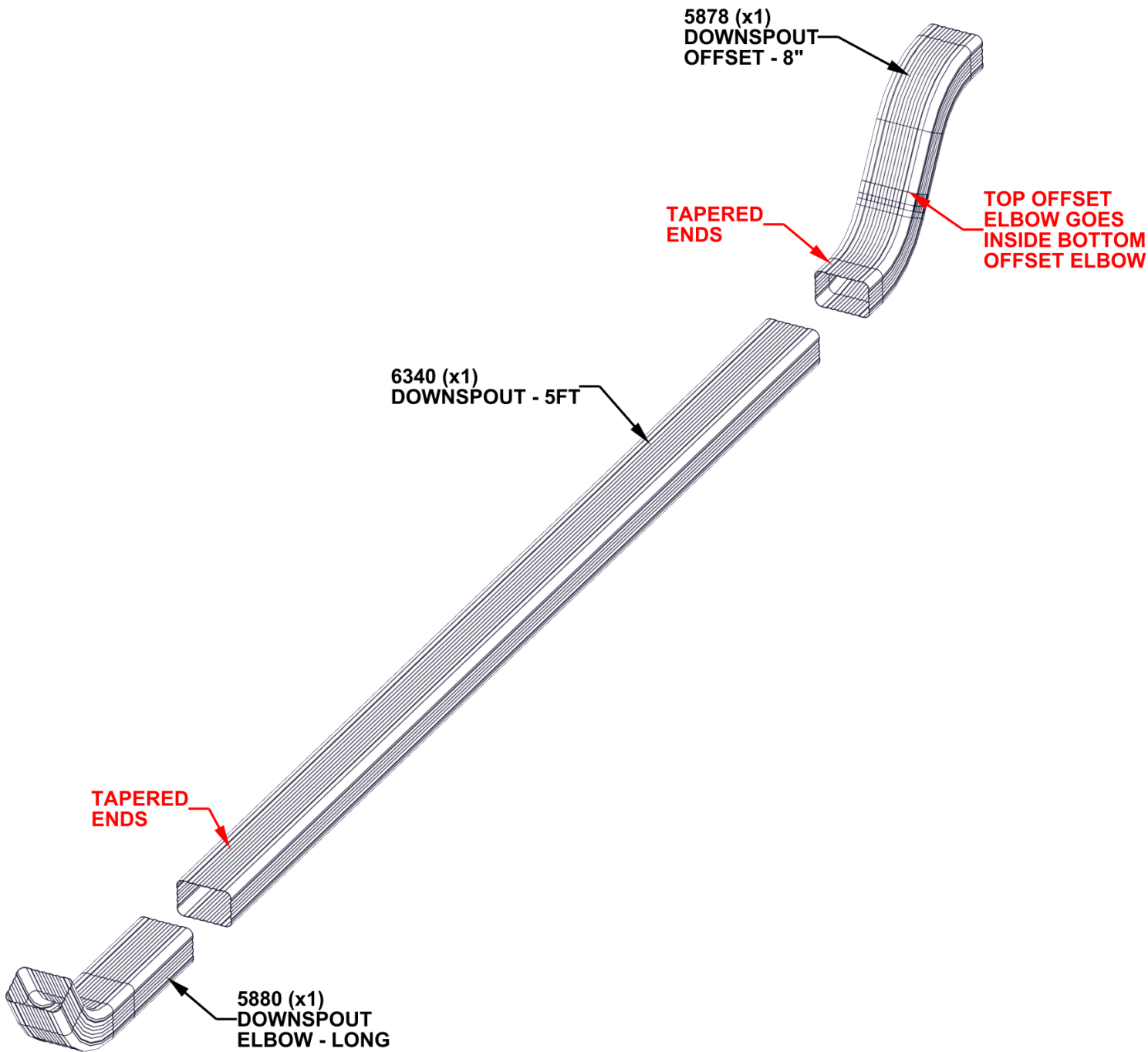

STEP 10 - GUTTER ASSEMBLY

QTY	PART NUMBER	DESCRIPTION
16	H101205	SCREW PWH 8x15x3/4 BLK

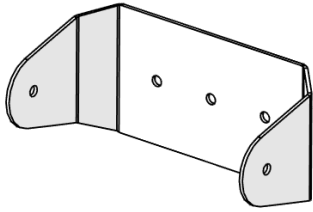

A4M06338 DOWNSPOUT CLIP
(x8)

- IT IS IMPORTANT TO CENTER 6338 CLIP AND HARDWARE ON POST.
- COMPLETE THIS STEP ON BOTH POSTS WHERE DOWNSPOUTS WILL BE LOCATED.

ATTENTION:
IF MOSQUITO NETTING IS ATTACHED, ZIP NETTING TOGETHER TO ENSURE IT CLOSSES COMPLETELY AND IS PULLED TIGHTLY, THEN FASTEN CLIP ON TOP OF NETTING.

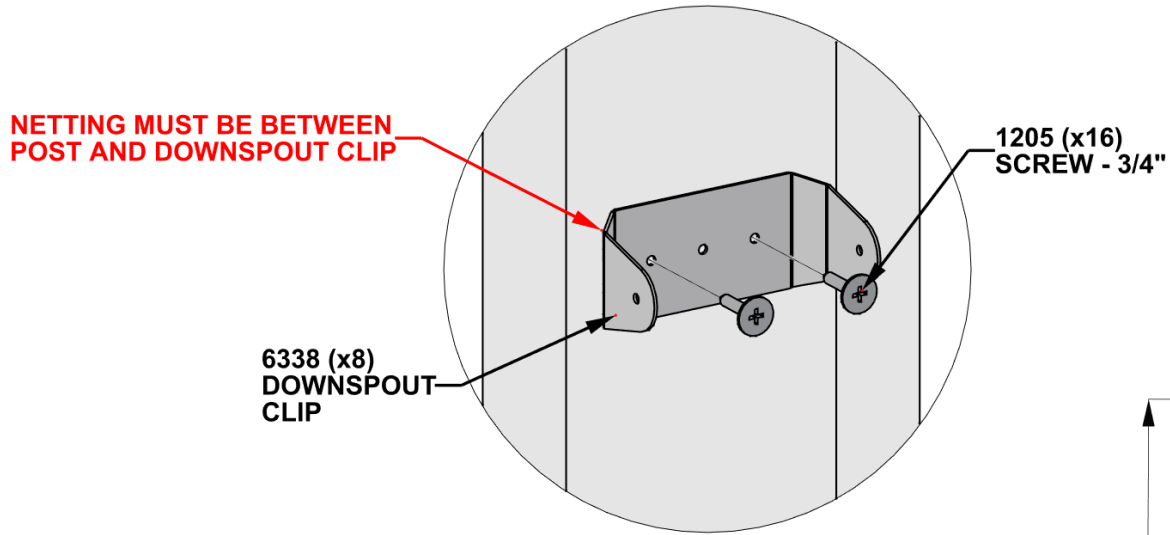

2 DOWNSPOUT CLIPS
PER POST ON BACK POST

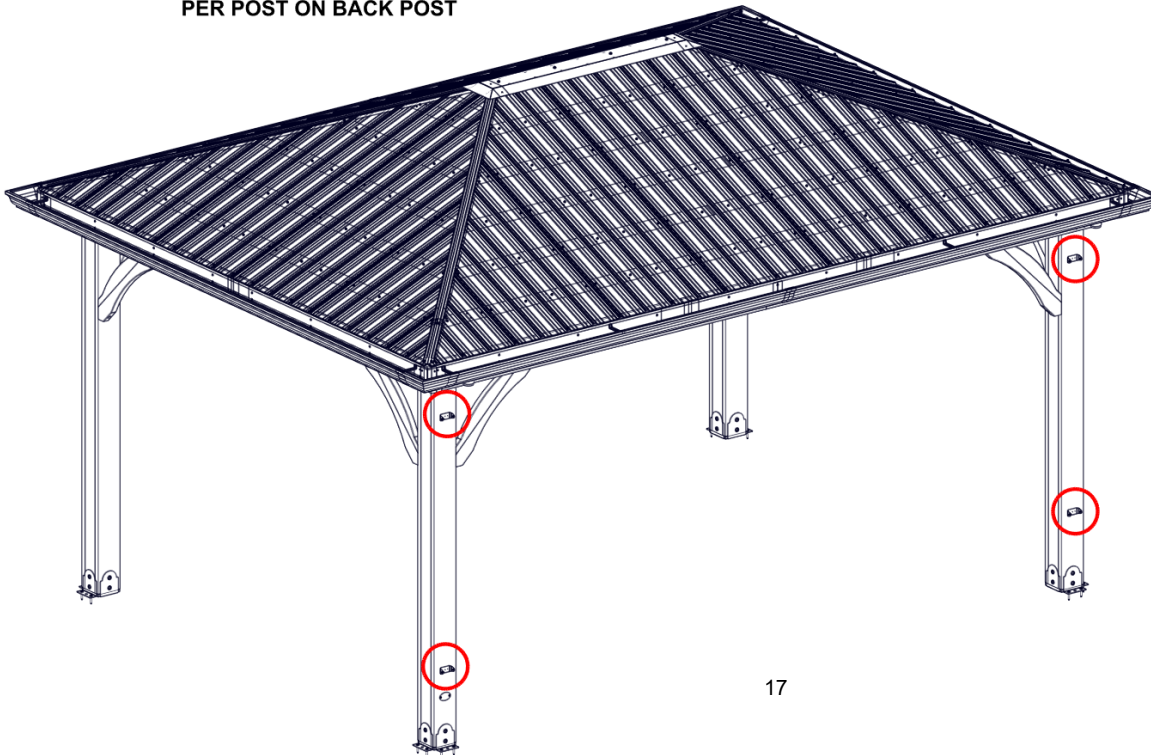

76-3/4" [1950mm]

17-1/2" [445mm]

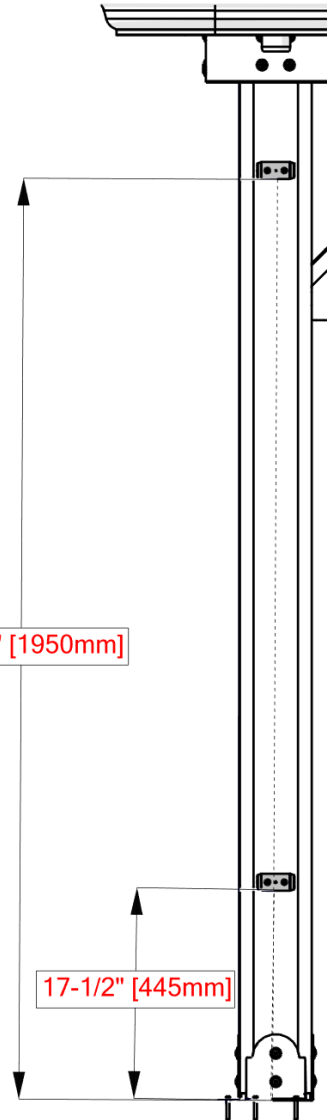

STEP 11 - GUTTER ASSEMBLY



DOWNSPOUT ASSEMBLY - STEP 9

QTY	PART NUMBER	DESCRIPTION
4	H101415	SCREW SELF PIERCING #8x1/2 BRN

- FASTEN DOWNSPOUT TO DOWNSPOUT OUTLETS USING HARDWARE PROVIDED.
- COMPLETE THIS STEP AT BOTH CORNERS.
- DOWNSPOUT WILL NOT REST ON THE GROUND, THERE WILL BE FLOATING SPACE.

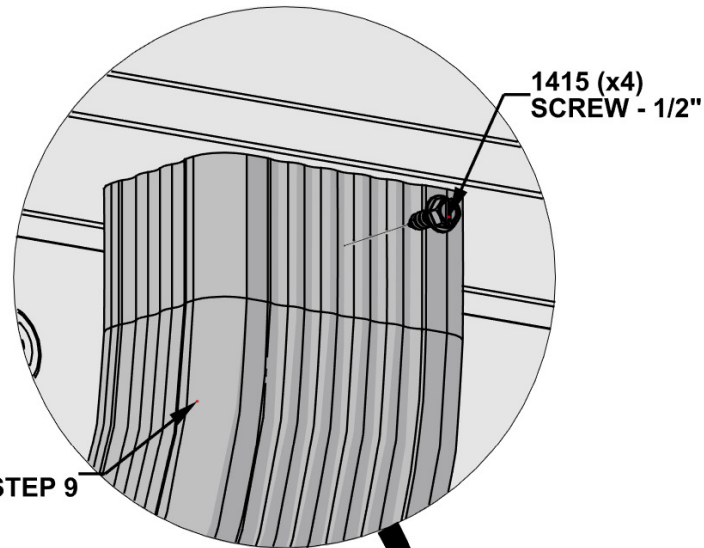

DOWNSPOUT ASSEMBLY - STEP 9

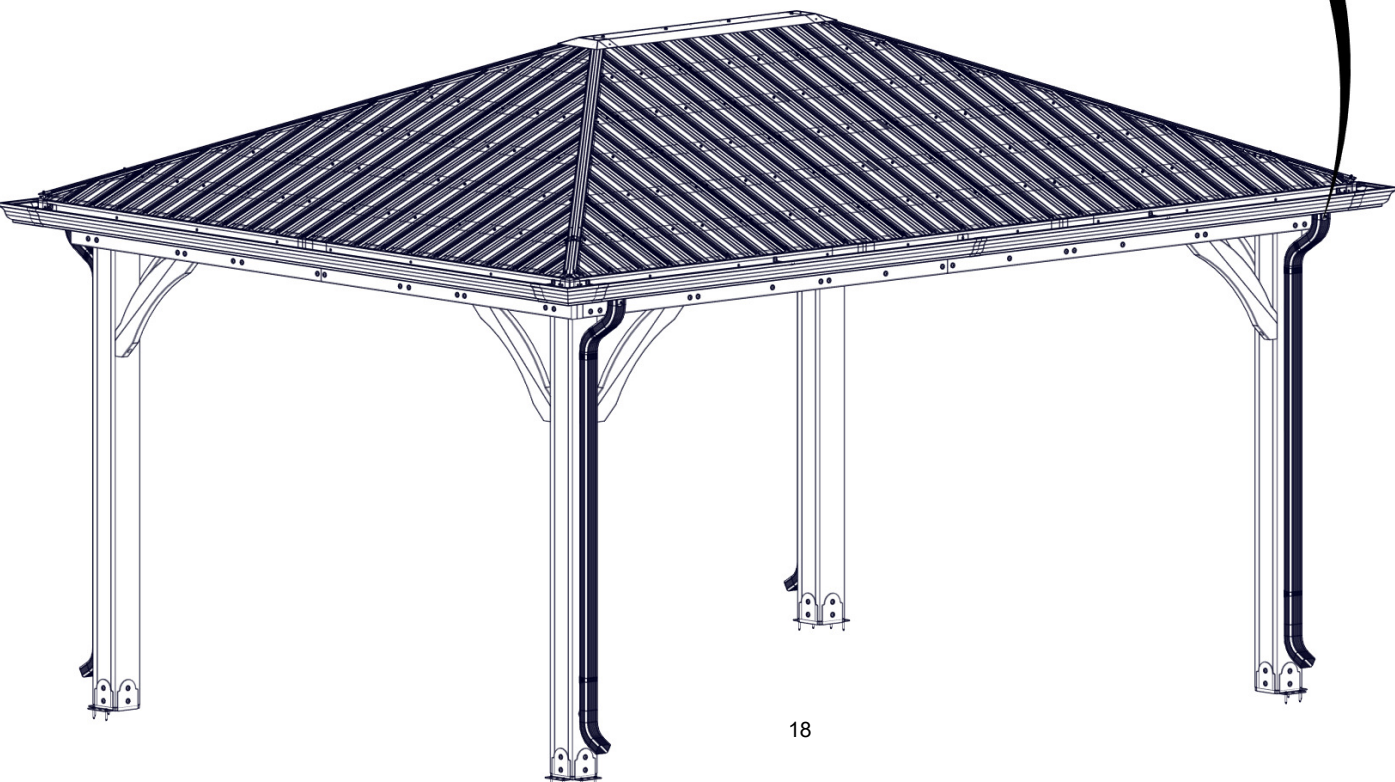

STEP 12 - GUTTER ASSEMBLY

QTY	PART NUMBER	DESCRIPTION
16	H101415	SCREW SELF PIERCING #8x1/2 BRN

- FASTEN DOWNSPOUT CLIP TO DOWNSPOUT.
- COMPLETE THIS STEP AT BOTH DOWNSPOUTS.

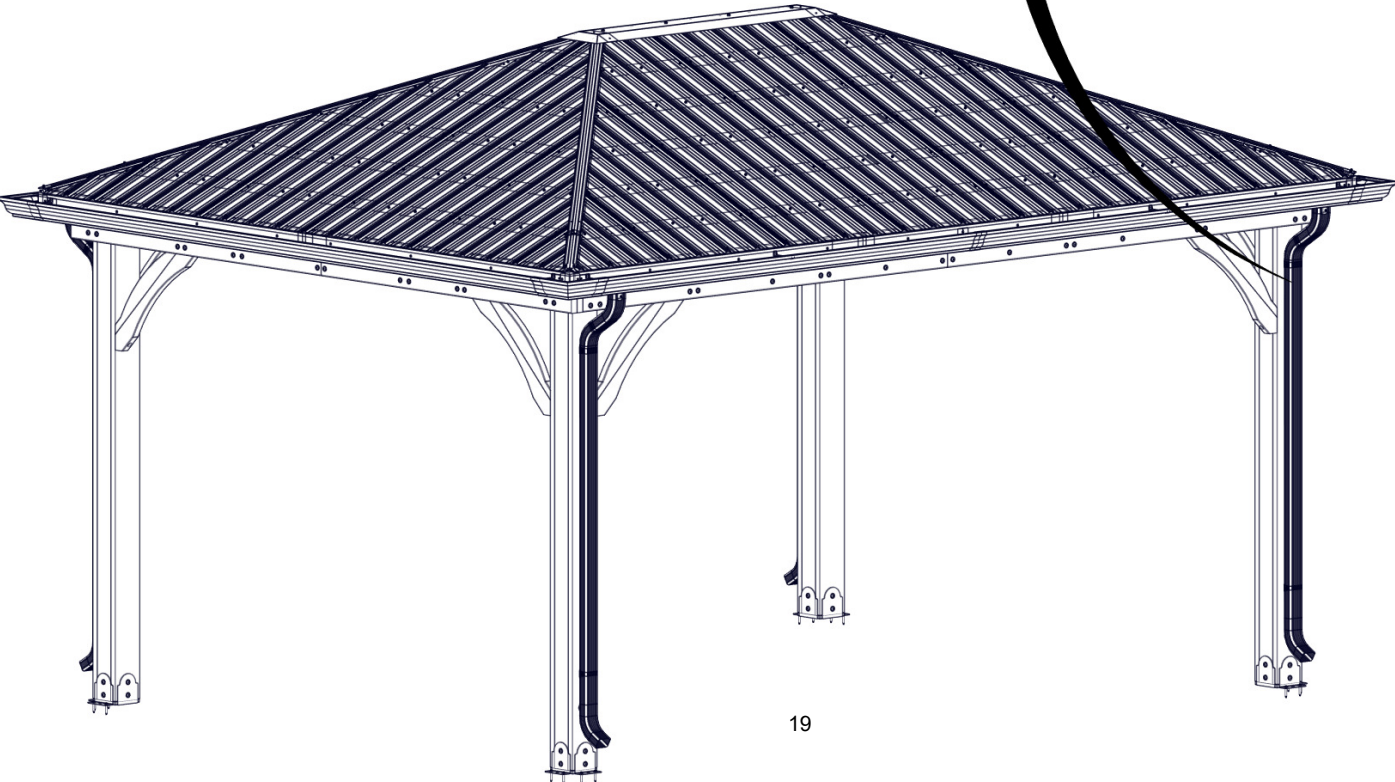
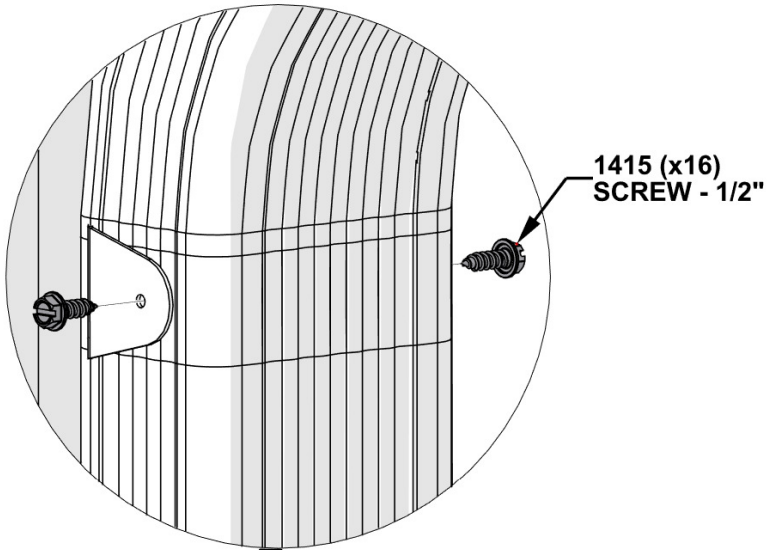

STEP 13 - GUTTER ASSEMBLY

QTY	PART NUMBER	DESCRIPTION
16	H101480	SCREW SELF TAPPING #9-1/4x1

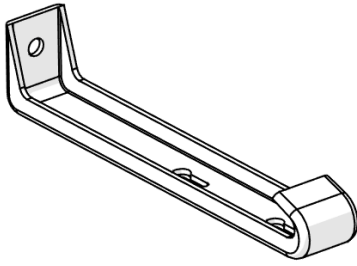

A4M04759 GUTTER HANGER
(x16)

- ATTACH ALL REMAINING GUTTER HANGERS.
- IT IS RECOMMENDED TO ATTACH THE MIDDLE HANGER FIRST, THEN EVENLY SPACE AND ATTACH THE REMAINING HANGERS.

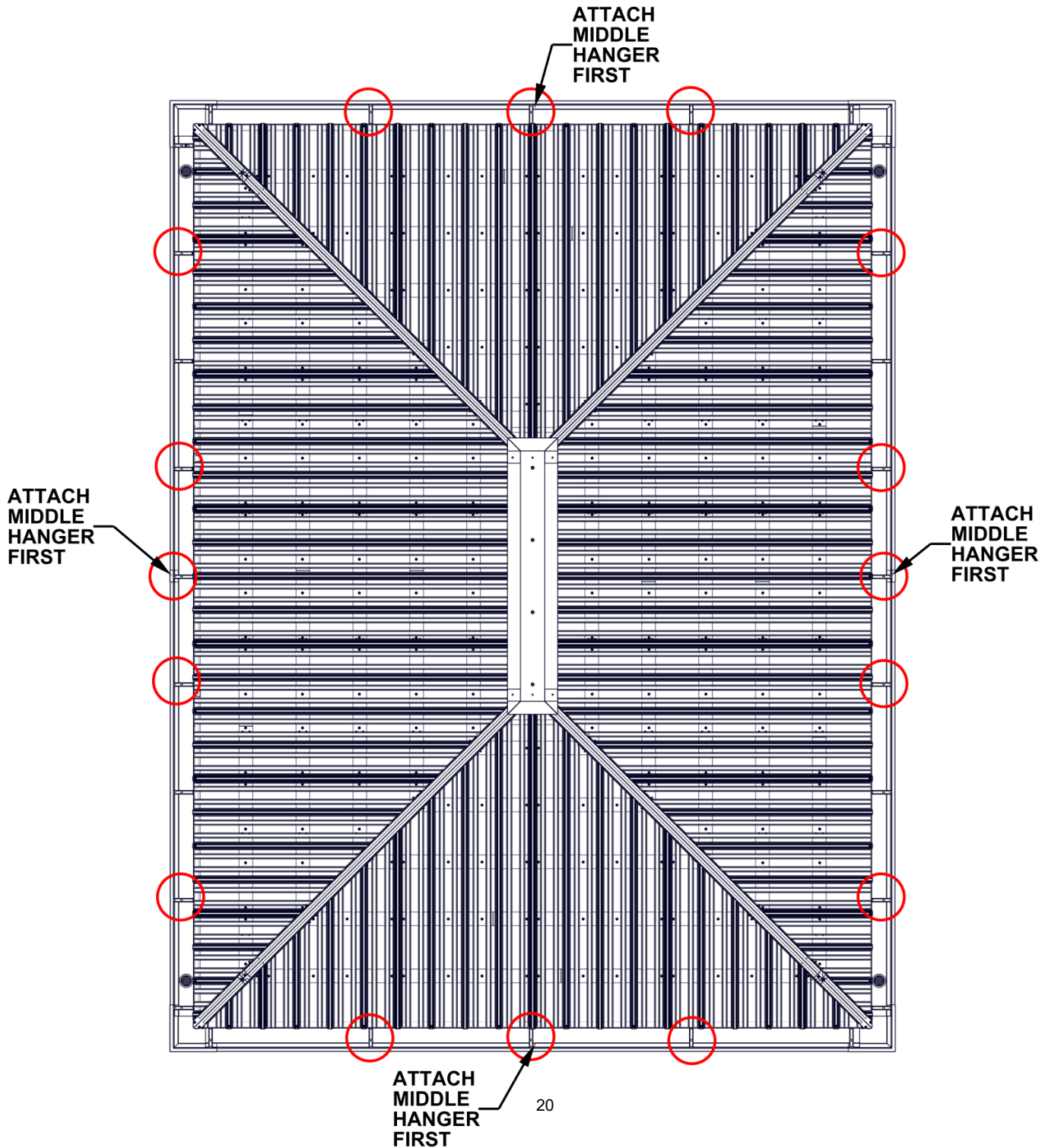

STEP 14 - GUTTER ASSEMBLY

CRITICAL:

AFTER HARDWARE AND GUTTERS ARE INSTALLED, IT IS IMPORTANT THAT A HEALTHY BEAD OF SILICONE IS WORKED INTO THE OVERLAPPING JOINTS CIRCLED IN RED. THE RED LINES INDICATE THE SPLICE JOINTS THAT NEED TO BE CAULKED TO AVOID LEAKING. MAKE SURE SILICONE IS APPLIED TO THE CURVED SURFACE OF GUTTERING AS WELL.

