



Manufactured by:
Backyard Discovery
3305 Airport Drive, Pittsburg, KS 66762
800-856-4445

*Basepoint Business Centre: Rivermead Drive, Westlea, Swindon SN5 7EX Phone: 0800-118-2476 J.P. Coenstraat 7,
The Bridge, The Hague, 2595 WP, Netherlands Phone: 08005678990*

16x12 NORWOOD GAZEBO GUTTER KIT

MODEL #: 9240568



Please visit www.backyarddiscovery.com
For the most up to date assembly manual, to register your product, or to order
replacement parts Para obtener instrucciones en español, visite
www.backyarddiscovery.com

OWNER'S MANUAL - PARTS IDENTIFICATION

Hardware Components



H101415 SCREW SELF PIERCING #8x1/2 BRN
(x10) #8 x 1/2

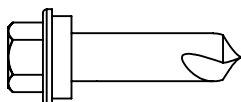

H101480 SCREW SELF TAPPING #9x1 BLK
(x18) 1/4 x 1

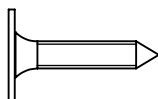

H101205 SCREW PWH BLK
(x8) 8x3/4

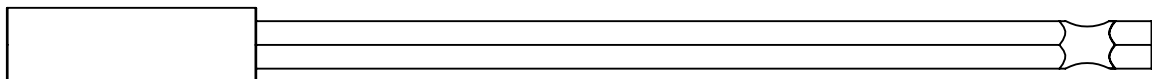

H101278 6" MAGNETIC DRIVER EXTENSION
(x1)



A6P01531 10 OZ SILICONE TUBE
(x1)

OWNER'S MANUAL - PARTS IDENTIFICATION

Hardware Components

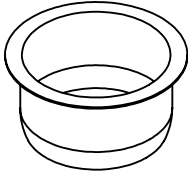

A4M04761 DOWNSPOUT OUTLET
(x2) 1 7/16"x2 7/8" [37x73]

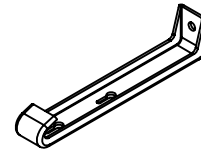

A4M04759 GUTTER HANGER
(x18) 3/4"x1"x4 15/16" [19x25x125]

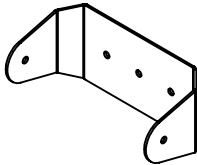

A4M06338 DOWNSPOUT CLIP
(x4) 1 7/16"x1 7/16"x3 1/8" [37x37x79]

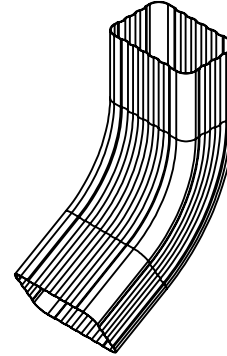

A4M05880 DOWNSPOUT ELBOW - LONG
(x2) 3"x10 5/8"x10 11/16" [76x270x271]

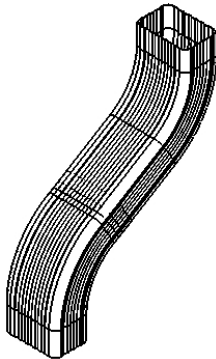

A4M05878 DOWNSPOUT OFFSET - 8IN
(x2) 3"x9 5/8"x12 9/16" [76x244x319]

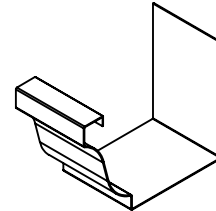

A4M06347 GUTTER SPLICE
(x2) 2 1/2"x3 11/16"x5 1/16" [64x94x129]



A4M06340 DOWNSPOUT - 60"
(x2) 2"x3"x60" [51x76x1525]

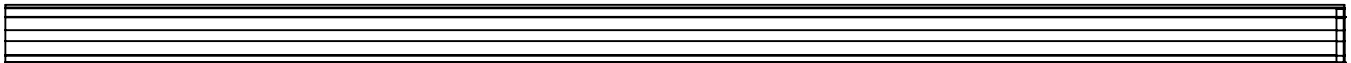

A4M06840 GUTTER W/ OUTLET
(x2) 3 11/16"x5 1/8"x95 5/8" [93x130x2429]



A4M06880 GUTTER
(x2) 3 11/16"x5 1/8"x95 5/8" [93x130x2429]

OFFSET ORIENTATION

TO ENSURE WATER FLOWS PROPERLY, IT IS IMPORTANT TO ORIENT DOWNSPOUT PIPING CORRECTLY. STARTING AT THE TOP, DOWNSPOUTS MUST FEED INTO THE NEXT SECTION AS SHOWN.

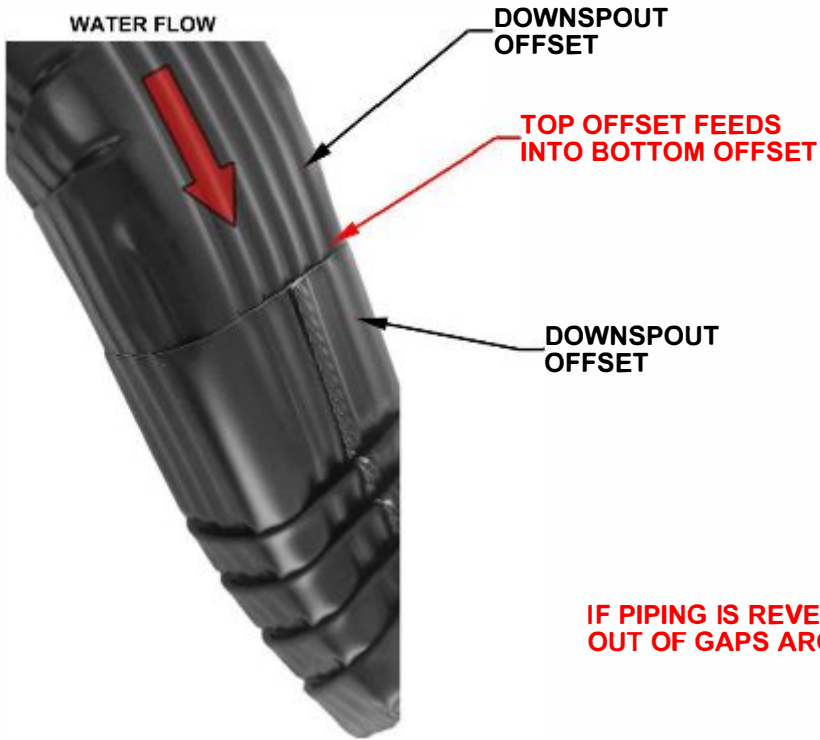

IF PIPING IS REVERSED, WATER WILL RUN OUT OF GAPS AROUND JOINTS

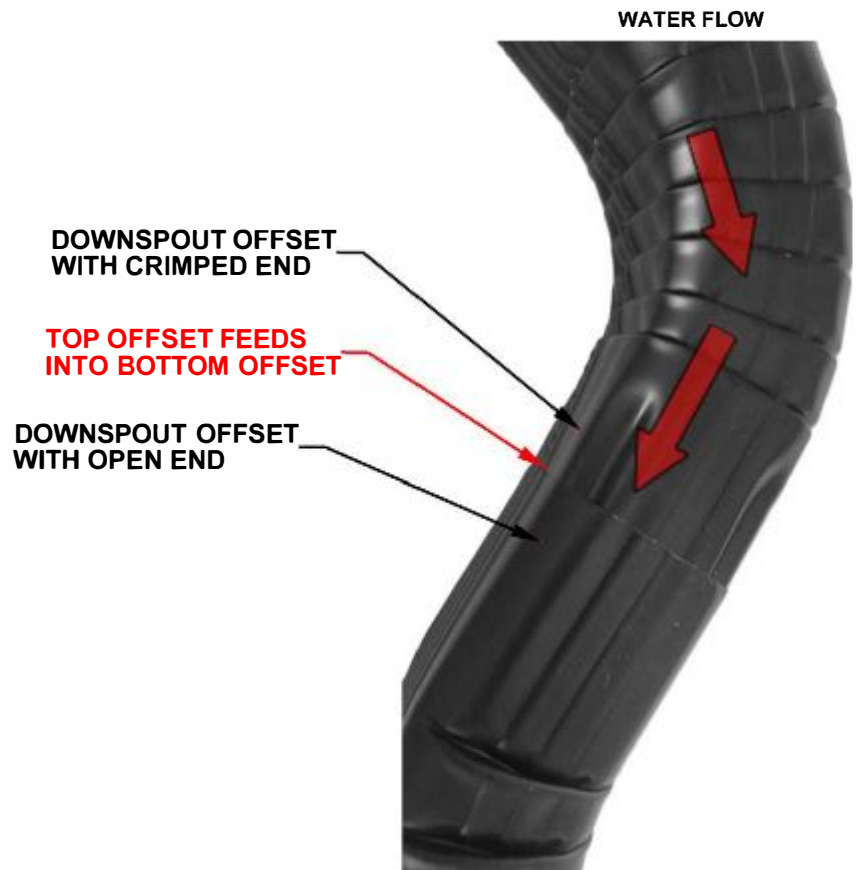

GUTTER SPLICE PAGE

- NOTE:**
- APPLY SILICONE TO INSIDE CHANNEL ON BOTH SIDES.
 - ENSURE SILICONE IS EVENLY APPLIED ALONG THE CHANNEL.
 - AFTER GUTTER SPLICE HAS BEEN SLID ONTO GUTTERS AND SILICONE HAS HAD TIME TO CURE, USING HAND PRESSURE ONLY, FOLD THE TOP TAB OVER EDGE OF GUTTER

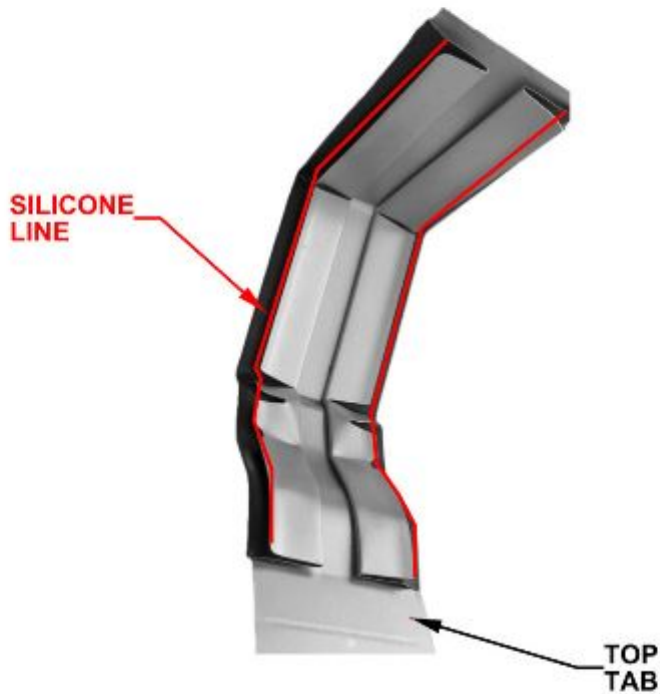
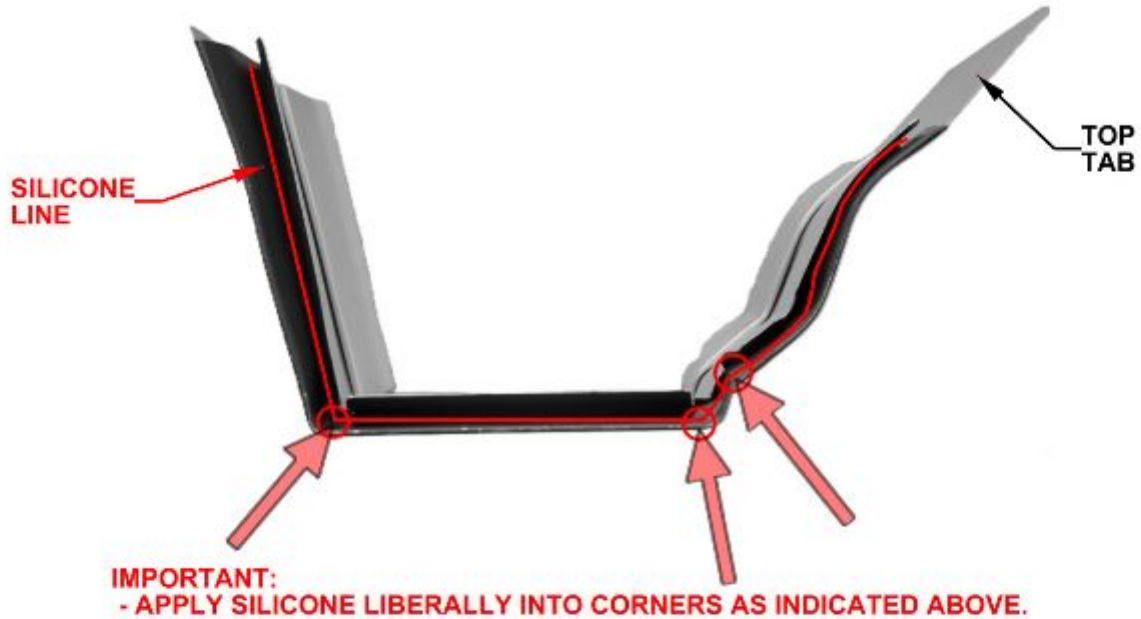

WAIT APPROXIMATELY 45 MINUTES FOR SILICONE TO BE COME TACKY.
AFTER 24 HOURS, SILICONE HAS CURED AND CAN HOLD WATER

STEP 1 - EDGE TRIM REMOVAL

QTY	PART NUMBER	DESCRIPTION
28	H100759	SCREW SELF TAPPING 1/4x1

- REMOVE EDGE TRIM AND HARDWARE SHOWN BELOW.
- SET HARDWARE AND PIECES ASIDE FOR LATER USE.



STEP 2 - GUTTER ASSEMBLY



A4M04761 DOWNSPOUT OUTLET
(x2)

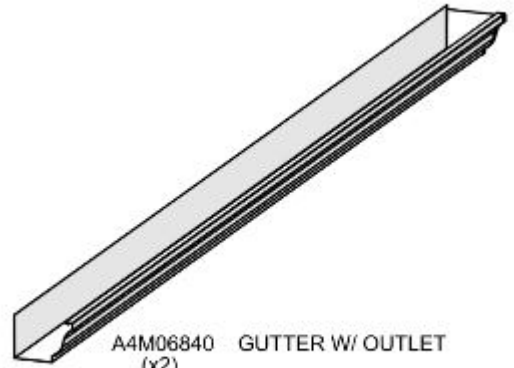

A4M06840 GUTTER W/ OUTLET
(x2)

- APPLY A BEAD OF SILICONE AROUND THE BOTTOM LIP OF THE DOWNSPOUT OUTLET AND PLACE OUTLET INSIDE GUTTER.
- COMPLETE THIS STEP TWICE.

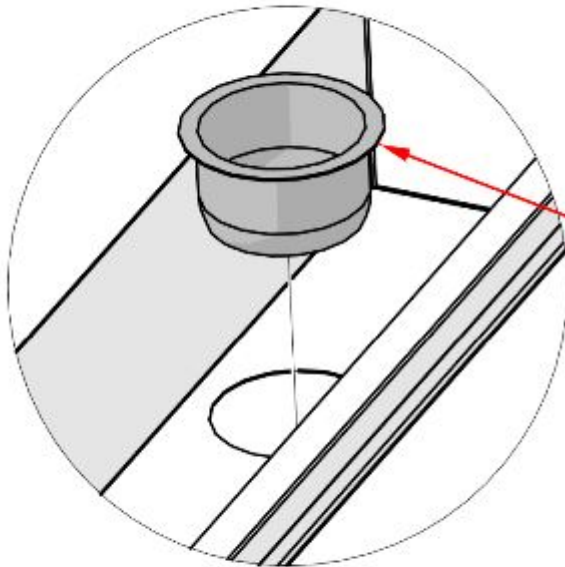

APPLY
SILICONE

4761 (x1)
DOWNSPOUT OUTLET

TIP: PRESSURE MAY NEED TO BE APPLIED TO GET OUTLET INTO POSITION. USE A WET FINGER TO FLATTEN SILICONE AFTER INSTALL.

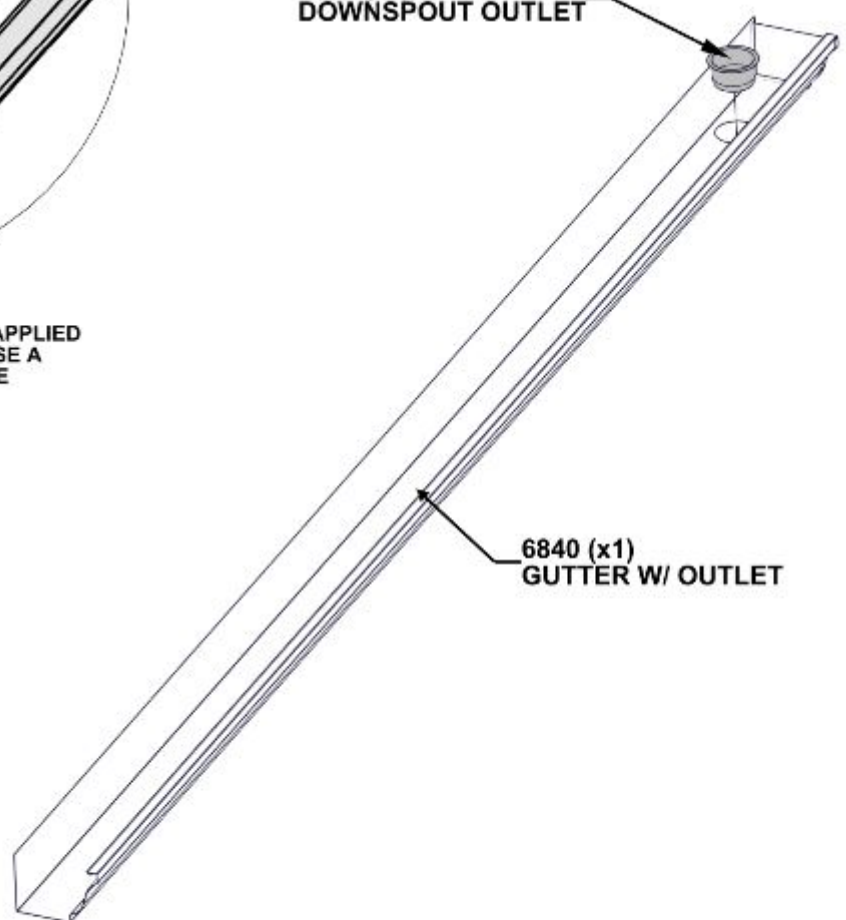

6840 (x1)
GUTTER W/ OUTLET

STEP 3 - GUTTER ASSEMBLY

QTY	PART NUMBER	DESCRIPTION
2	H101480	SCREW SELF TAPPING #9x1 BLK



GUTTER W/ OUTLET ASSEMBLY - STEP 2



A4M04759 GUTTER HANGER (x2)

- SLIDE GUTTER UP TO ROOF LINE.
- FLUSH INSIDE GUTTER WITH FASCIA BOARD.
- ATTACH FIRST GUTTER HANGER APPROXIMATELY 4" [100mm] FROM EDGE OF GUTTER.
- ATTACH THE SECOND GUTTER HANGER AT THE 9TH ROOF RIB.
- USE A CLAMP TO HOLD THE GUTTER TO THE BEAM FOR ASSISTANCE.
- PRE-DRILL 1/8" [3mm] PILOT HOLES FOR EASE OF ASSEMBLY.

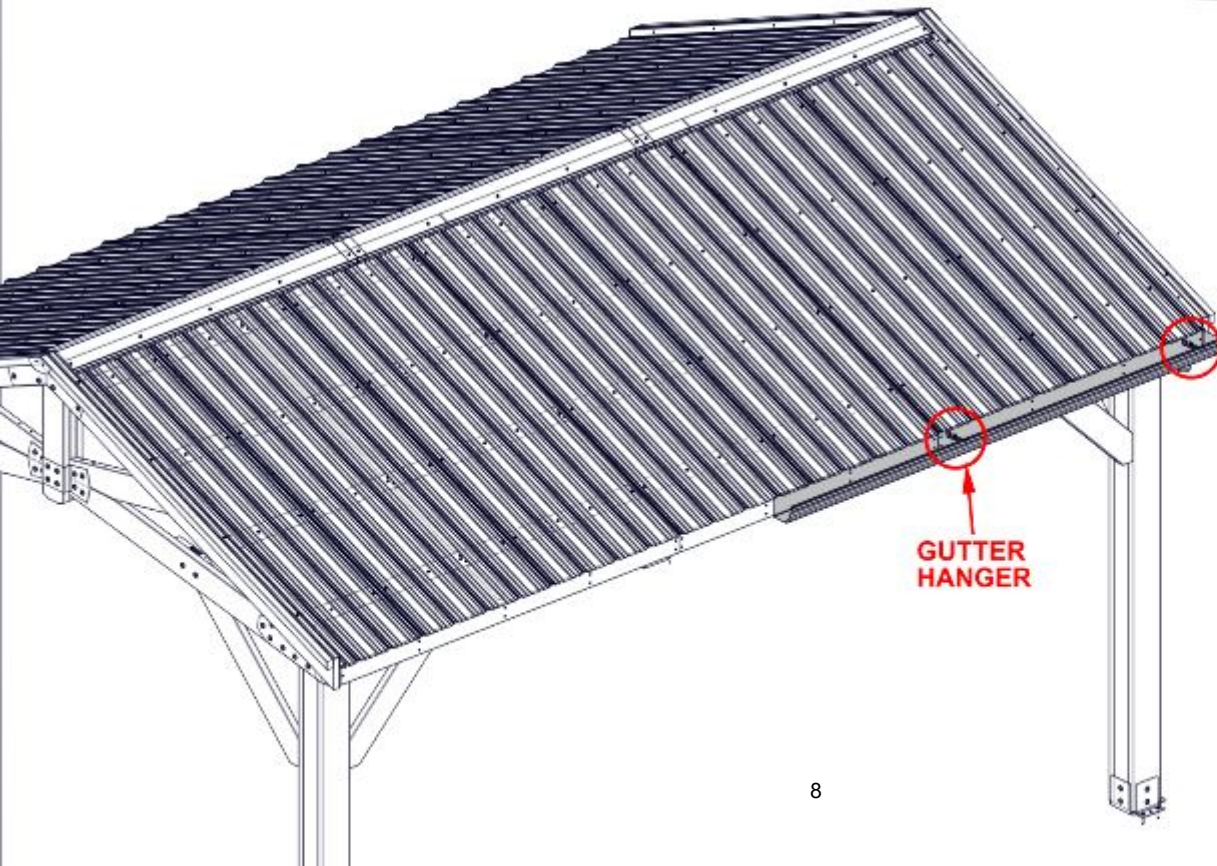
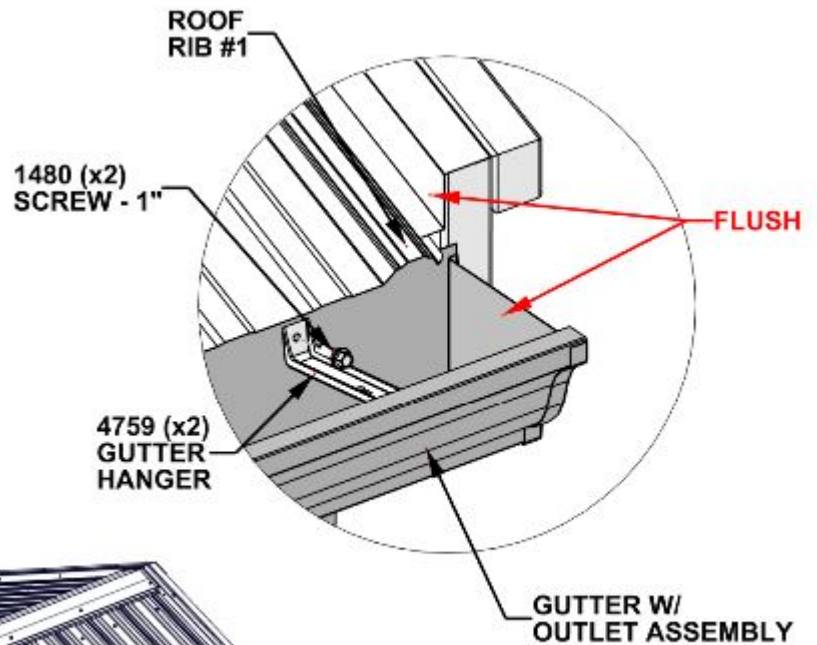

STEP 4 - GUTTER ASSEMBLY

QTY	PART NUMBER	DESCRIPTION
2	H101480	SCREW SELF TAPPING #9x1 BLK



A4M06880 GUTTER
(x1)

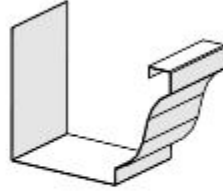

A4M06347 GUTTER SPLICE
(x1)



A4M04759 GUTTER HANGER
(x2)

- SLIDE GUTTER UP TO ROOF LINE.
- FLUSH INSIDE GUTTER WITH FASCIA BOARD.
- ATTACH FIRST GUTTER HANGER APPROXIMATELY 4" [100mm] FROM EDGE OF GUTTER.
- ATTACH THE SECOND GUTTER HANGER AT THE 8TH ROOF RIB.
- USE A CLAMP TO HOLD THE GUTTER TO THE BEAM FOR ASSISTANCE.
- PRE-DRILL 1/8" [3mm] PILOT HOLES FOR EASE OF ASSEMBLY.

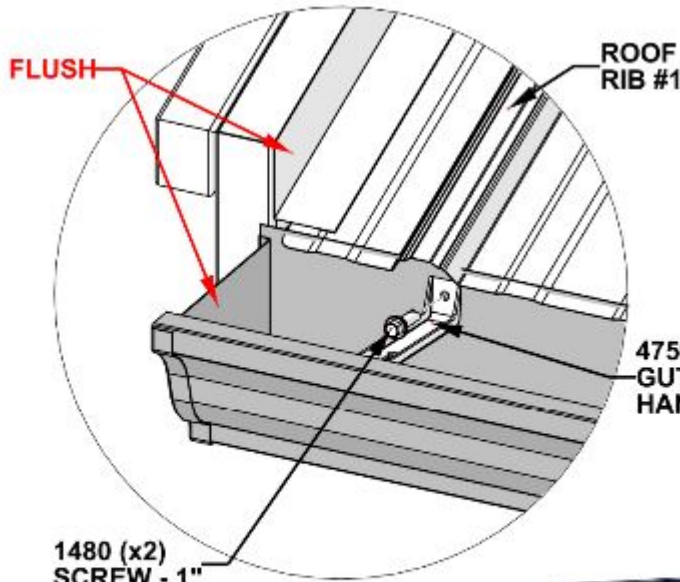

FLUSH

ROOF RIB #1

4759 (x2)
GUTTER HANGER

1480 (x2)
SCREW - 1"

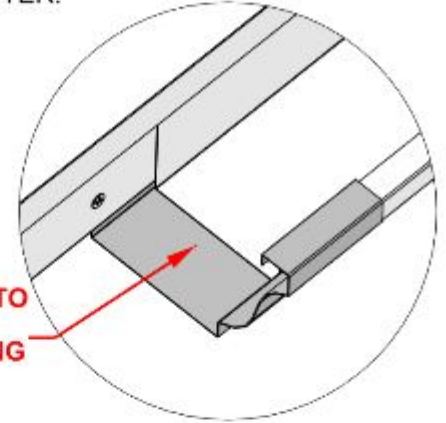

APPLY SILICONE TO
SPLICE GROOVE
BEFORE INSERTING
INTO GUTTER

APPLY SILICONE TO
SPLICE GROOVE
BEFORE INSERTING
GUTTER INTO SPLICE

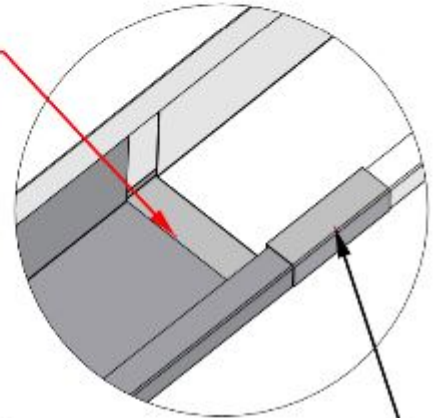

6347 (x1)
GUTTER SPLICE

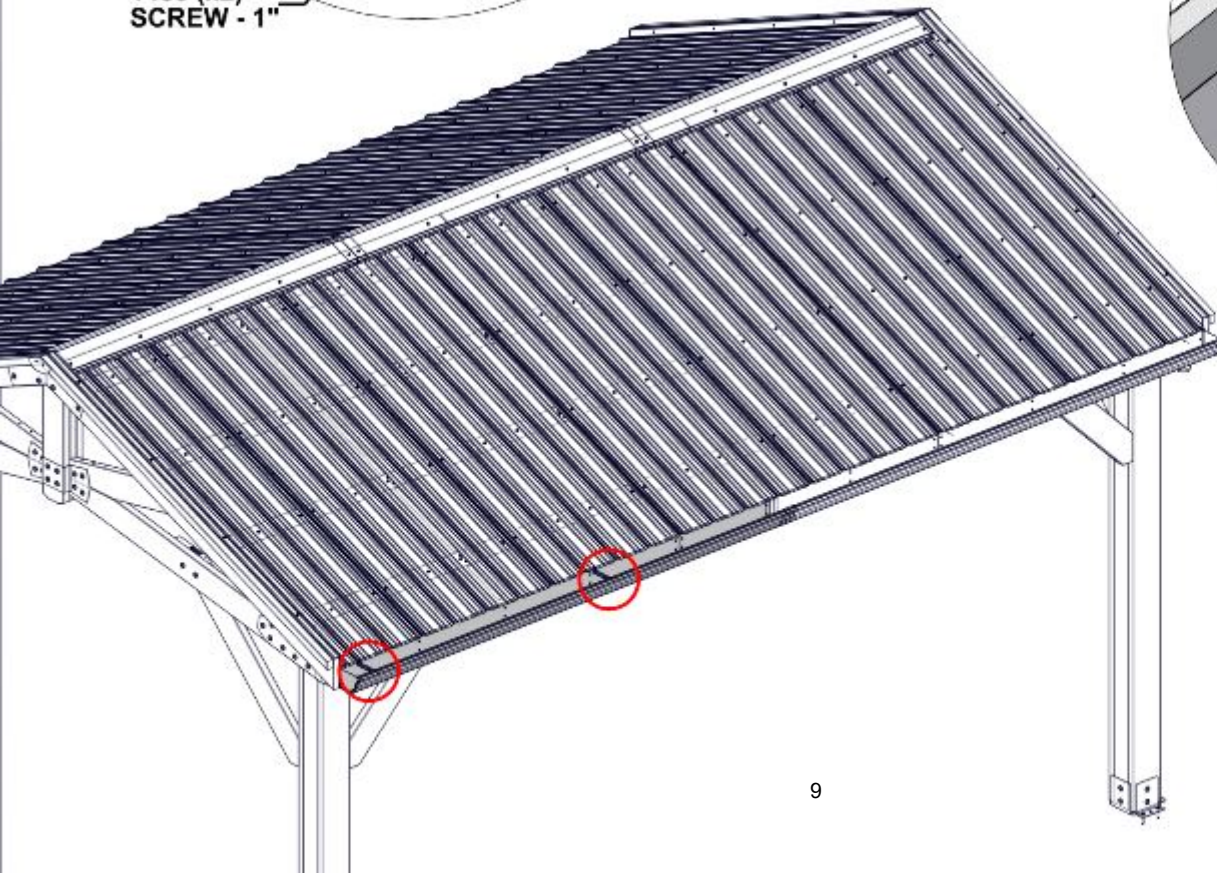

STEP 5 - GUTTER ASSEMBLY

QTY	PART NUMBER	DESCRIPTION
2	H101480	SCREW SELF TAPPING #9x1 BLK



GUTTER W/ OUTLET ASSEMBLY - STEP 2



A4M04759 GUTTER HANGER (x2)

- SLIDE GUTTER UP TO ROOF LINE.
- FLUSH INSIDE GUTTER WITH FASCIA BOARD.
- ATTACH FIRST GUTTER HANGER APPROXIMATELY 4" [100mm] FROM EDGE OF GUTTER.
- ATTACH THE SECOND GUTTER HANGER AT THE 9TH ROOF RIB.
- USE A CLAMP TO HOLD THE GUTTER TO THE BEAM FOR ASSISTANCE.
- PRE-DRILL 1/8" [3mm] PILOT HOLES FOR EASE OF ASSEMBLY.

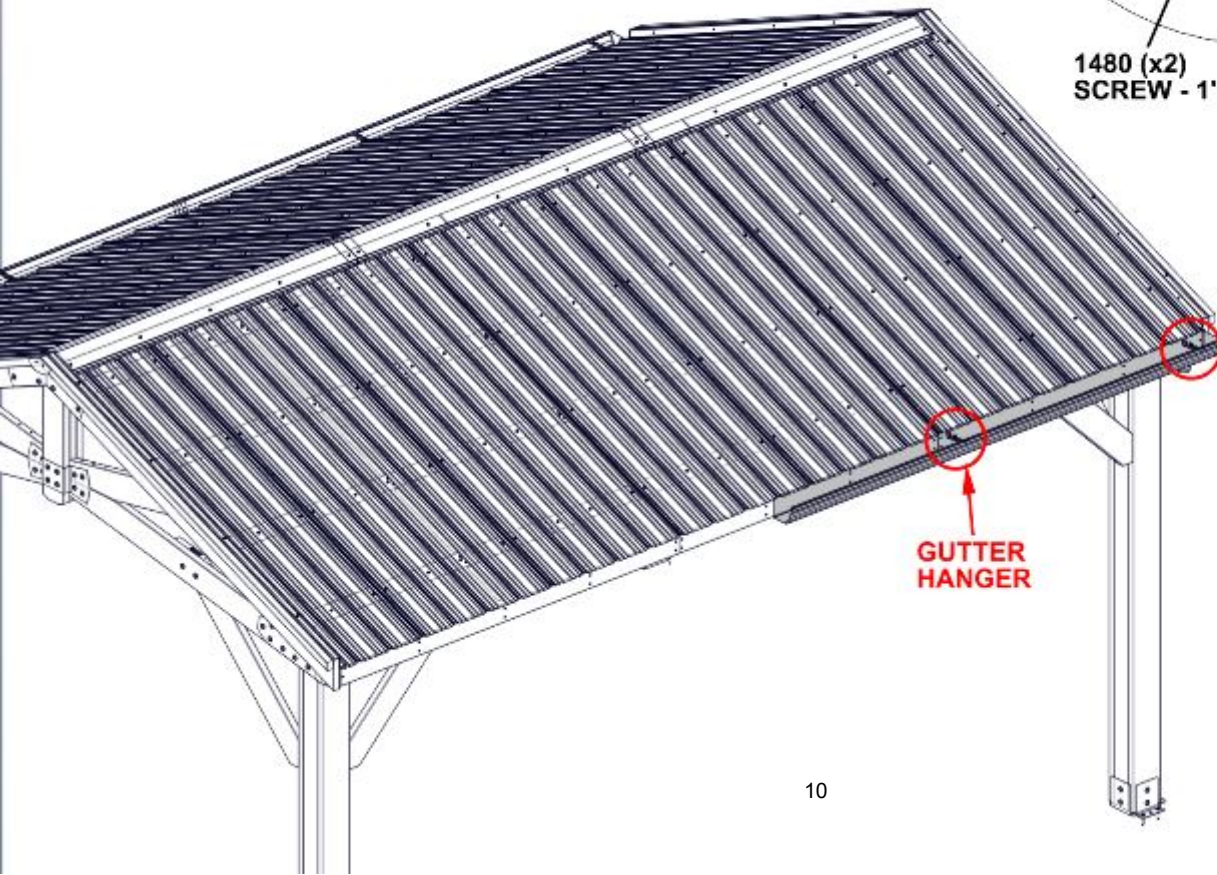
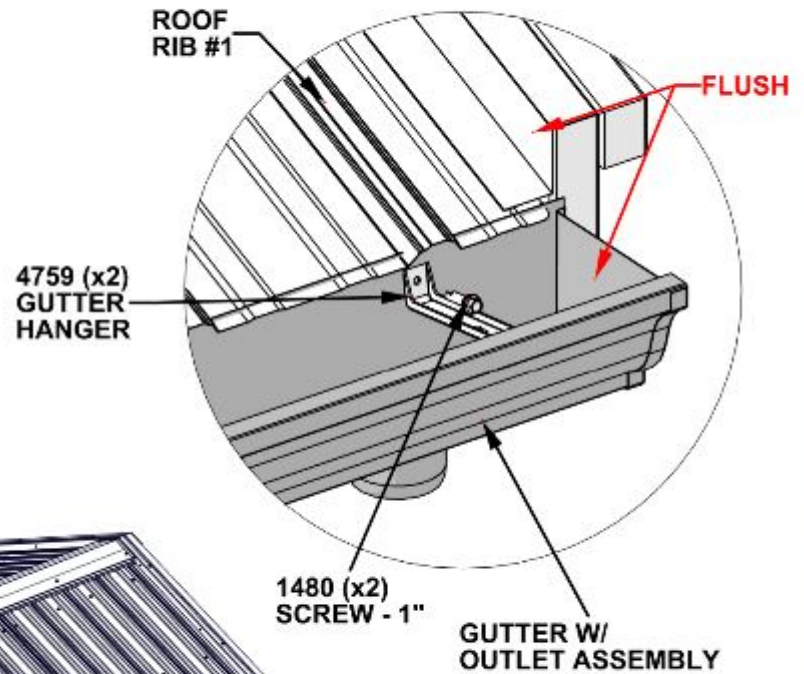

STEP 6 - GUTTER ASSEMBLY

QTY	PART NUMBER	DESCRIPTION
2	H101480	SCREW SELF TAPPING #9x1 BLK



A4M06880 GUTTER
(x1)

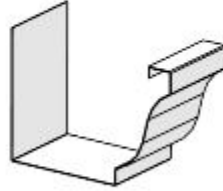

A4M06347 GUTTER SPLICE
(x1)



A4M04759 GUTTER HANGER
(x2)

- SLIDE GUTTER UP TO ROOF LINE.
- FLUSH INSIDE GUTTER WITH FASCIA BOARD.
- ATTACH FIRST GUTTER HANGER APPROXIMATELY 4" [100mm] FROM EDGE OF GUTTER.
- ATTACH THE SECOND GUTTER HANGER AT THE 8TH ROOF RIB.
- USE A CLAMP TO HOLD THE GUTTER TO THE BEAM FOR ASSISTANCE.
- PRE-DRILL 1/8" [3mm] PILOT HOLES FOR EASE OF ASSEMBLY.

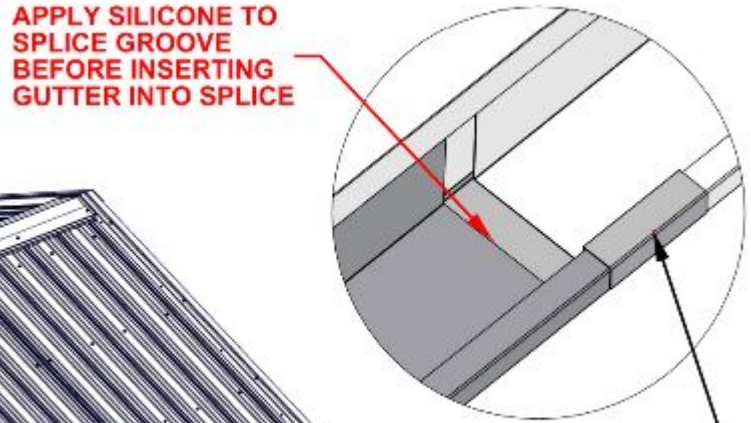
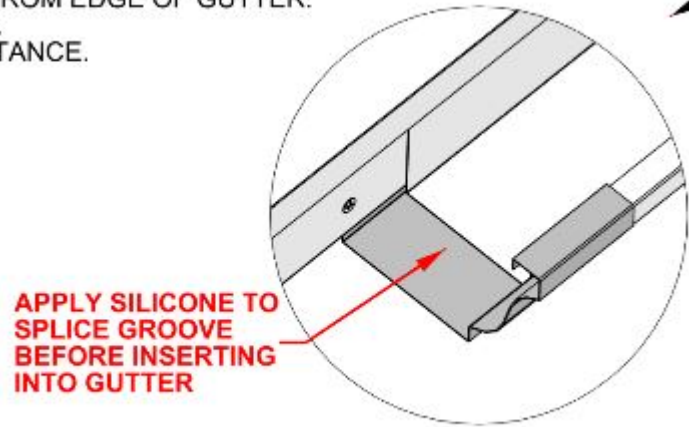
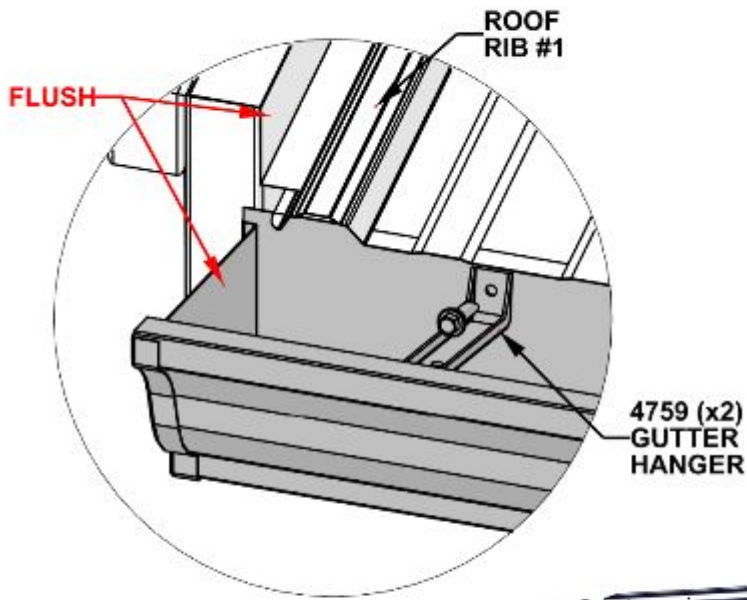

6347 (x1)
GUTTER
SPLICE

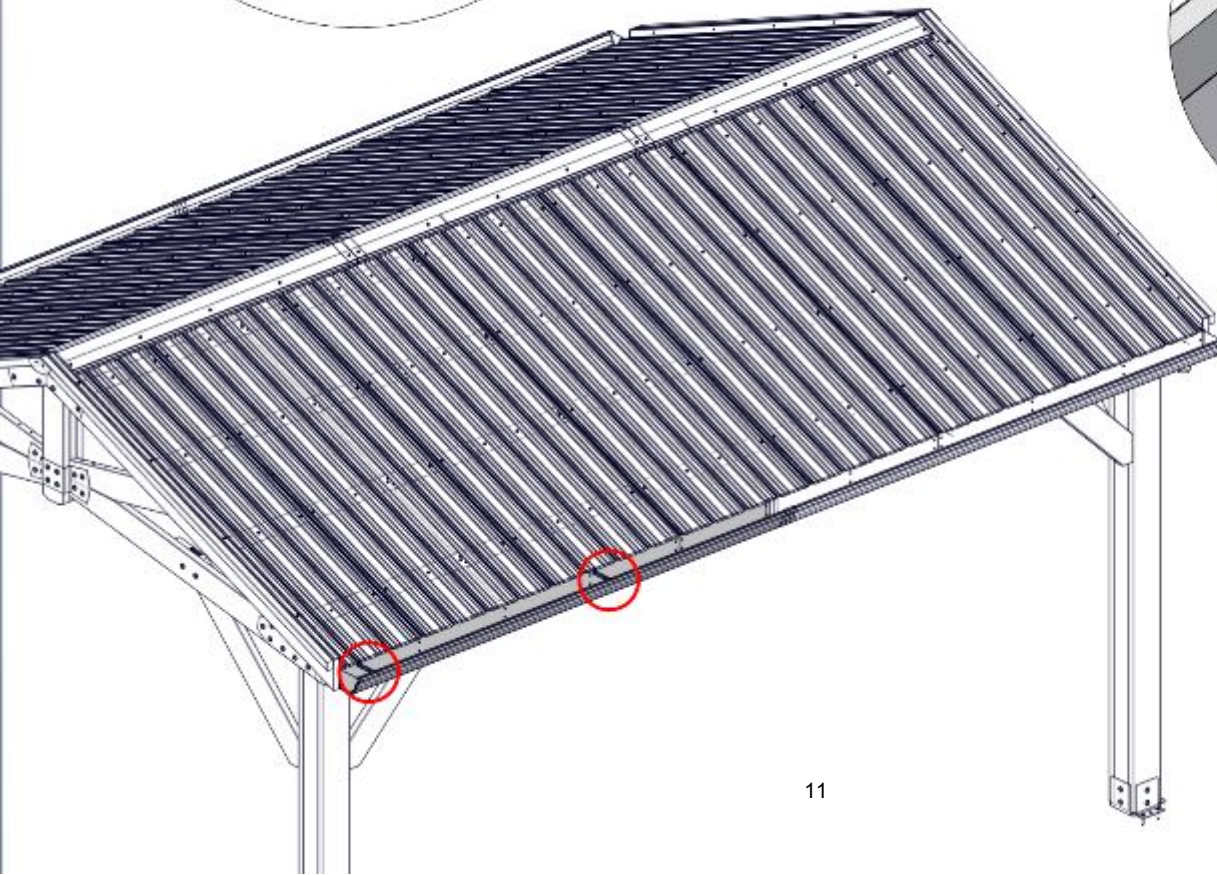

STEP 7 - GUTTER ASSEMBLY

QTY	PART NUMBER	DESCRIPTION
8	H101205	SCREW PWH 8x15x3/4 BLK

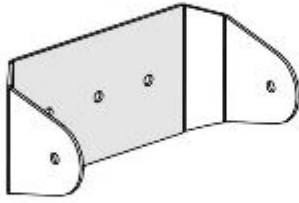

A4M08338 DOWNSPOUT CLIP
(x4)

- IT IS IMPORTANT TO CENTER 6338 CLIP AND HARDWARE ON POST.
- COMPLETE THIS STEP ON THE 2 CORNERS WITH A DOWNSPOUT OUTLET.

ATTENTION: IF MOSQUITO NETTING IS ATTACHED, ZIP NETTING TOGETHER TO ENSURE IT CLOSURES COMPLETELY AND IS PULLED TIGHTLY, THEN FASTEN CLIP ON TOP OF NETTING

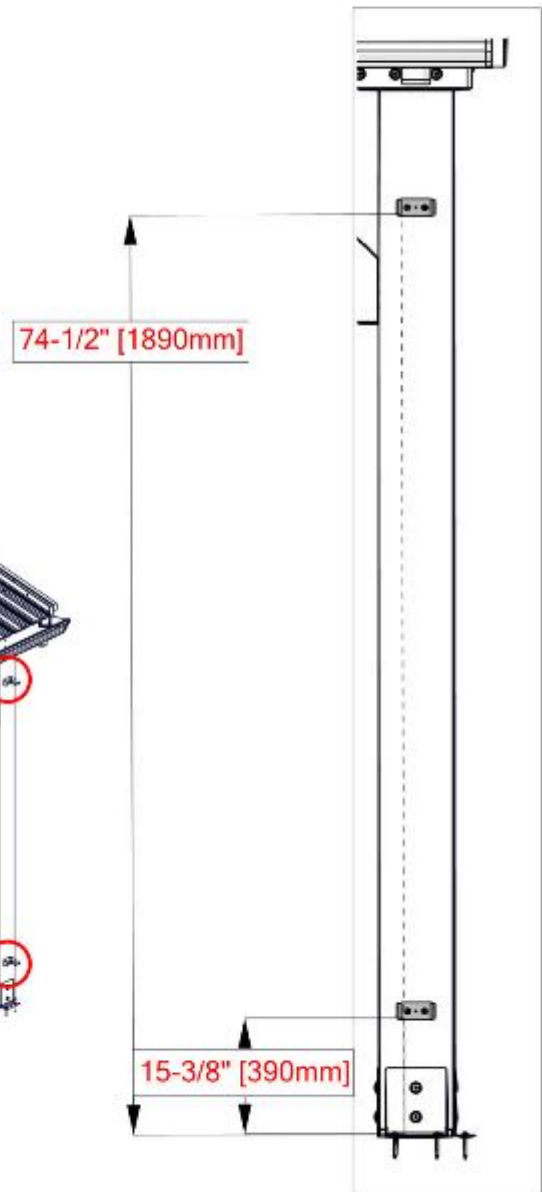
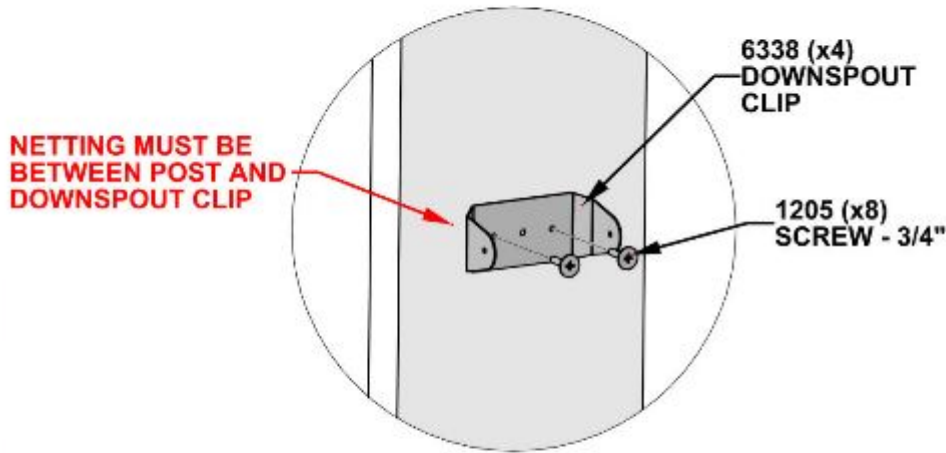

STEP 8 - GUTTER ASSEMBLY



A4M05880 DOWNSPOUT ELBOW - LONG
(x2)



A4M05878 DOWNSPOUT OFFSET - 8"
(x2)



A4M06340 DOWNSPOUT - 60"
(x2)

- INSERT TAPERED ENDS INTO LARGER ENDS AS SHOWN.
- NOTE ORIENTATION OF DOWNSPOUT OFFSET. SEE DOWNSPOUT OFFSET PAGE FOR DETAIL.
- COMPLETE THIS STEP TWICE.

5878 (x1)
DOWNSPOUT OFFSET - 8IN

TAPERED
END

NOTE TOP OFFSET
ELBOW GOES INSIDE
BOTTOM OFFSET ELBOW

6340 (x1)
DOWNSPOUT - 60"

TAPERED
END

5880 (x1)
DOWNSPOUT ELBOW - LONG

STEP 9 - GUTTER ASSEMBLY



QTY	PART NUMBER	DESCRIPTION
2	H101415	SCREW SELF TAPPING #8x1/2 BRN

DOWNSPOUT ASSEMBLY - STEP 8

- SLIDE DOWNSPOUT ASSEMBLY OVER GUTTER OUTLET AND ATTACH WITH HARDWARE PROVIDED.
- NOTE GUTTER WILL NOT EXTEND TO GROUND, THERE WILL BE FLOATING SPACE.
- COMPLETE THIS AT BOTH CORNERS WITH DOWNSPOUT OUTLET.

1415 (x2)
SCREW - 1/2"

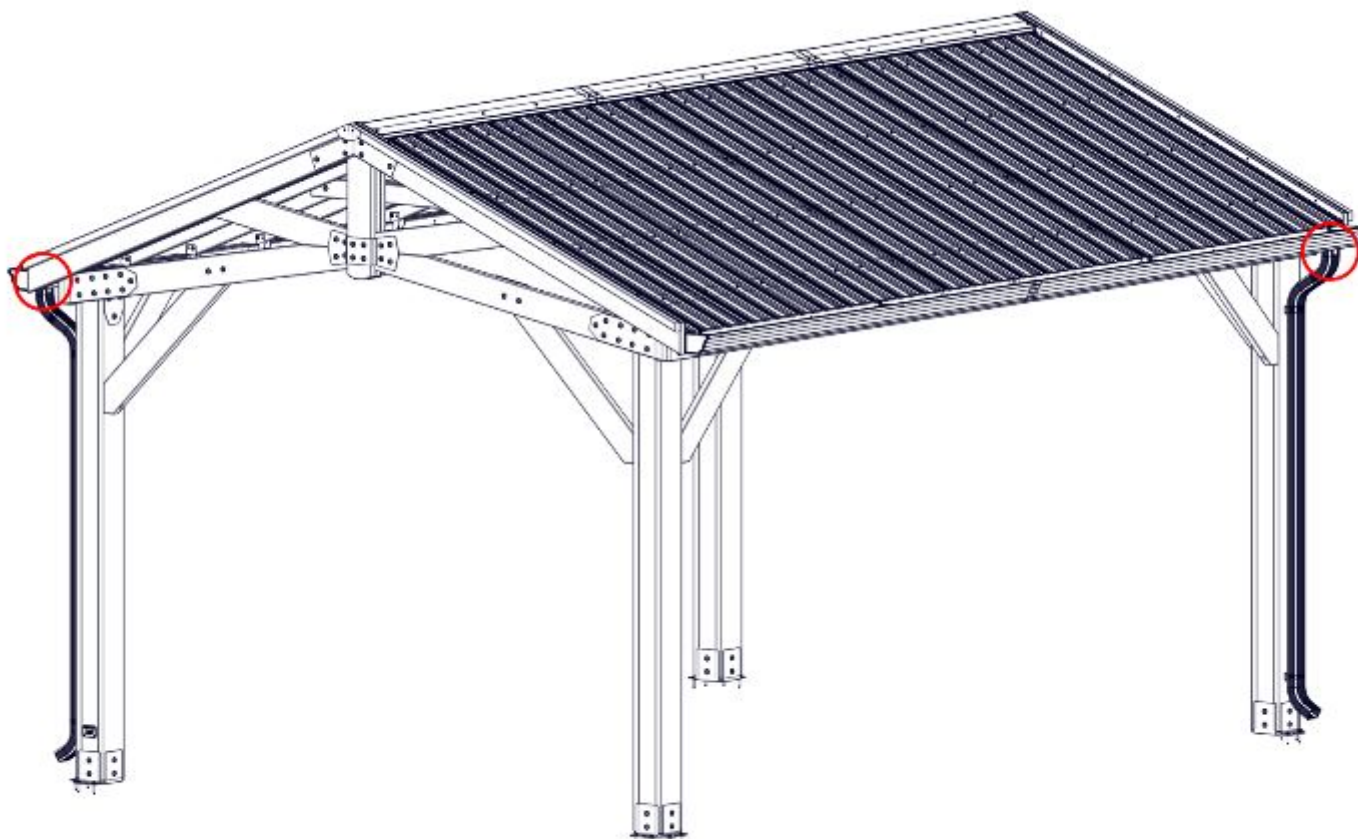
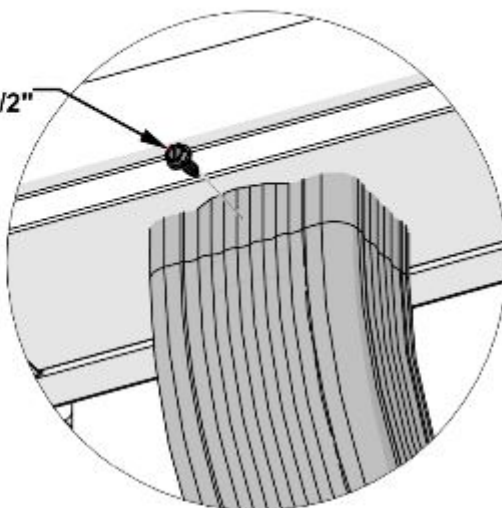

STEP 10 - GUTTER ASSEMBLY

QTY	PART NUMBER	DESCRIPTION
8	H101415	SCREW SELF TAPPING #8x1/2 BRN

- ATTACH DOWNSPOUT CLIPS TO DOWNSPOUTS.

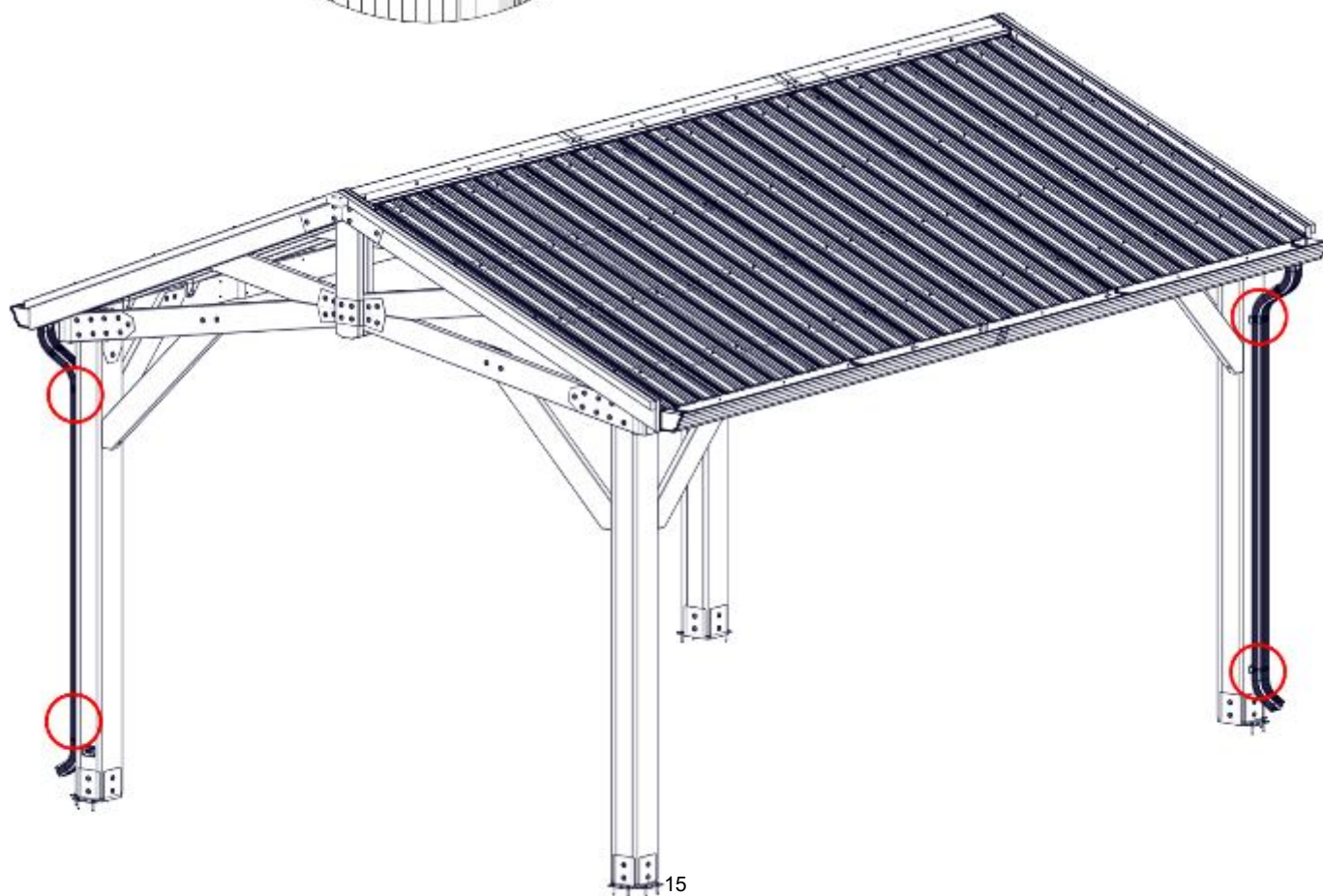
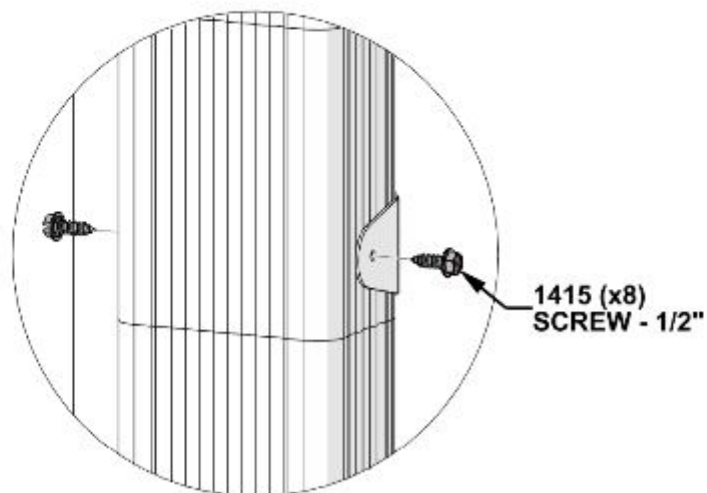

STEP 11 - GUTTER ASSEMBLY

QTY	PART NUMBER	DESCRIPTION
8	H101480	SCREW SELF TAPPING #9x1 BLK



A4M04759 GUTTER HANGER
(x8)

- ATTACH REMAINING GUTTER HANGERS AS SHOWN.
- SPACE HANGERS APPROXIMATELY 25-3/8" [645mm] APART.

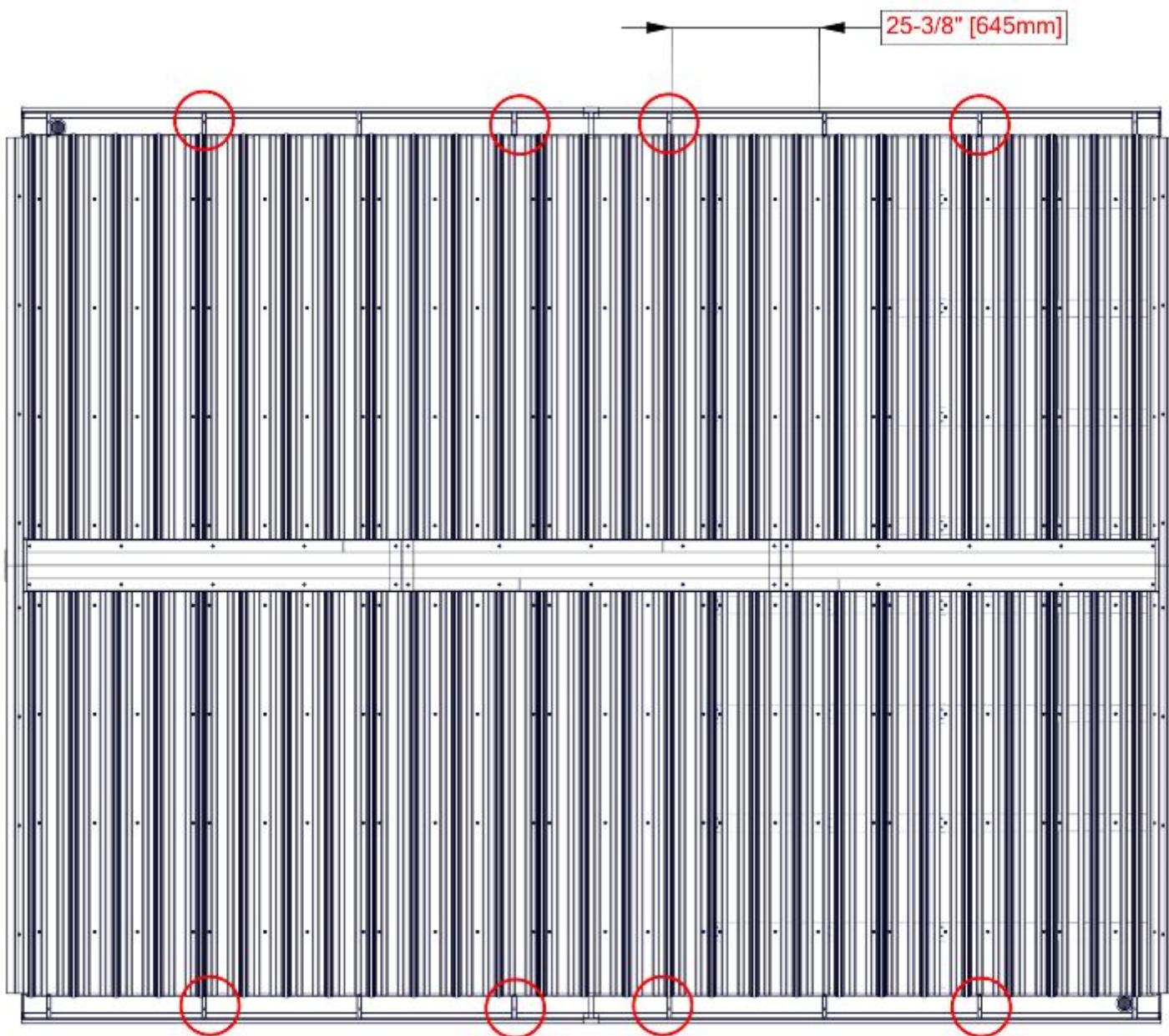

STEP 12 - GUTTER ASSEMBLY

CRITICAL:

AFTER HARDWARE AND GUTTERS ARE INSTALLED IT IS IMPORTANT THAT A HEALTHY BEAD OF SILICONE IS WORKED INTO THE OVERLAPPING JOINTS CIRCLED IN RED. THE RED LINES INDICATE THE SPLICE JOINTS THAT NEED TO BE CAULED TO AVOID LEAKING. MAKE SURE SILICONE IS APPLIED TO THE CURVED SURFACES OF GUTTERING AS WELL.

TIP: A WET FINGER HELPS WORK SILICONE INTO SPACES.

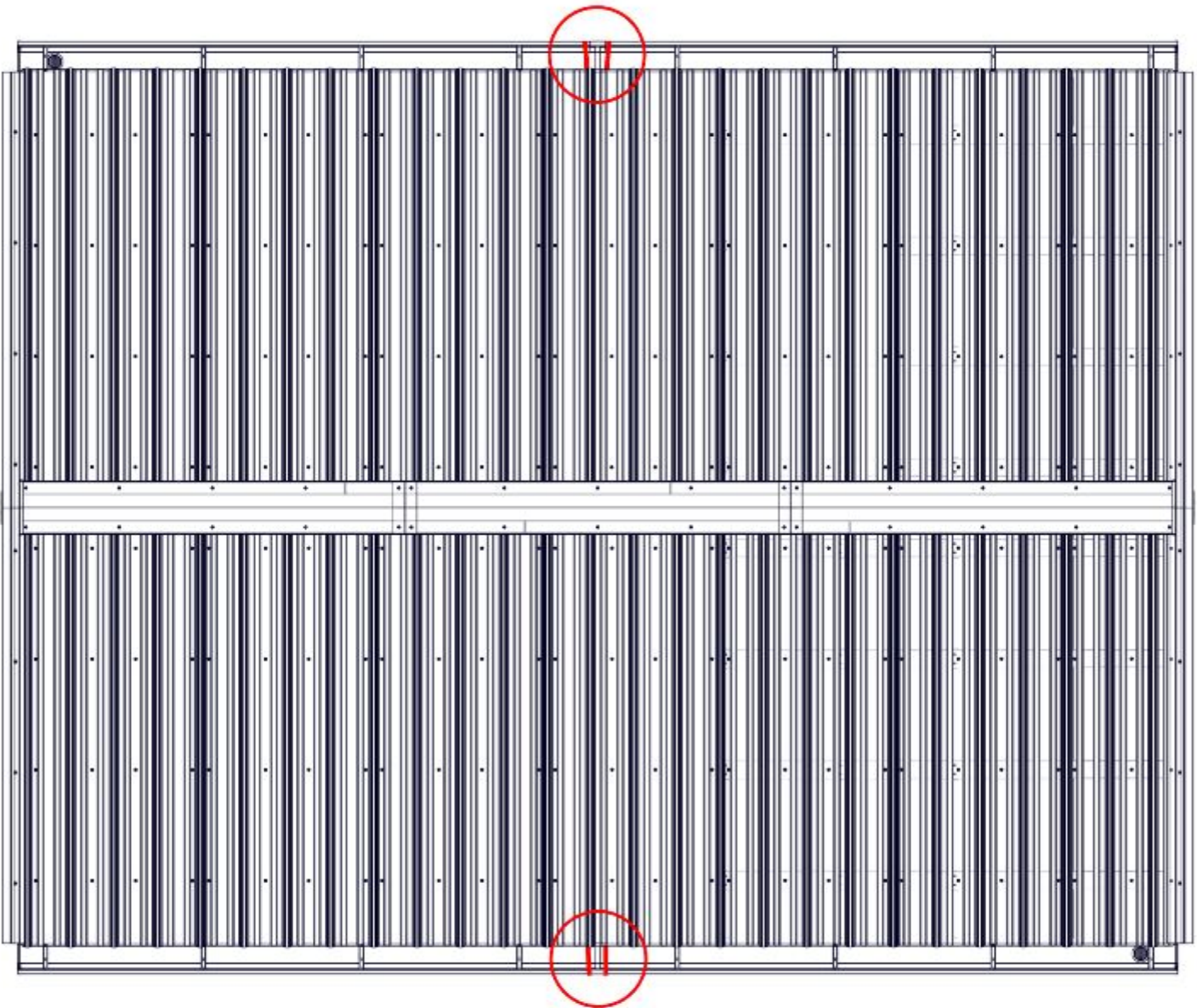

STEP 13 - EDGE TRIM INSTALL

QTY	PART NUMBER	DESCRIPTION
28	H100759	SCREW SELF TAPPING 1/4x1

- RE-INSTALL EDGE TRIM AND HARDWARE SHOWN BELOW.
- RE-USE THE EXISTING HOLES TO AVOID LEAKS.

