



MANUFACTURED BY:
Backyard Discovery
 3305 Airport Drive, Pittsburg, KS 66762
 800-856-4445

Basepoint Business Centre: Rivermead Drive, Westlea, Swindon SN5 7EX Phone: 0800-118-2476
 J.P. Coenstraat 7, The Bridge, The Hague, 2595 WP, Netherlands Phone: 0800-567-8990

TUBE SLIDE

RIGHT HAND EXIT

Model # 9198074

The assembly manual must be retained since it contains important information



WARNING

Adult Assembly Required.

Not suitable for children under 36 months due to small parts.
FOR DOMESTIC USE ONLY. INTENDED FOR OUTDOOR USE.



Please visit www.backyarddiscovery.com

For the most up to date assembly manual, to register your set, or to order replacement parts
Para obtener instrucciones en español, visite www.backyarddiscovery.com



EASY STEP-BY-STEP
3D INTERACTIVE INSTRUCTIONS

DOWNLOAD THE FREE APP



INSTALLATION SERVICES AVAILABLE!
See inside for details

Made in China
INS-9198074-A-TUBE SLIDE-RH-ENG 07-12-22

Owner's Manual - Basic Setup Dimensions & Assembly Notes

Place the set on level ground, not less than 6'-7" [2 m] from any structure or obstruction such as a fence, garage, house, overhanging branches, laundry lines, or electrical wires.

- While assembling unit, take time before and after each phase to make sure fort is level. If fort is not level, assembly will be difficult and improper assembly may result. Extra care must be taken to insure the fort is square.
 - The safe play area refers to a zone extending 6'-7" (2 m) beyond the play product on all sides, including the space above the play product.
-

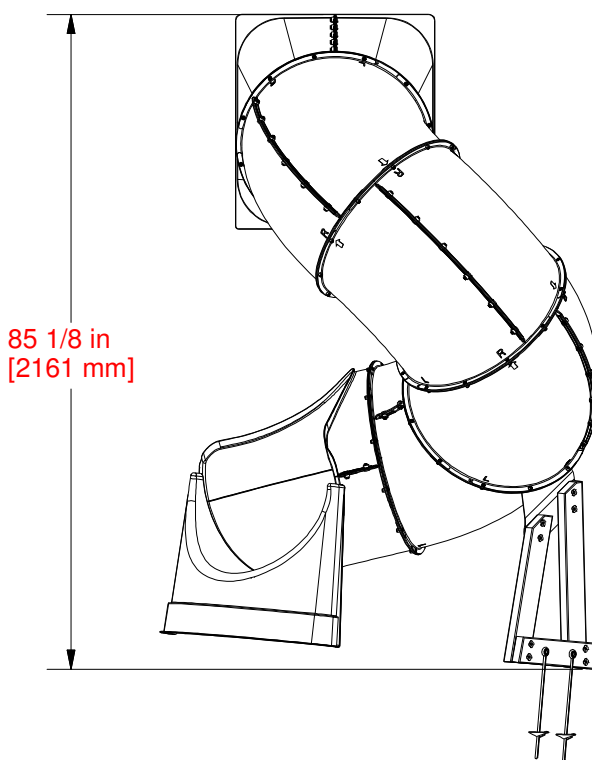
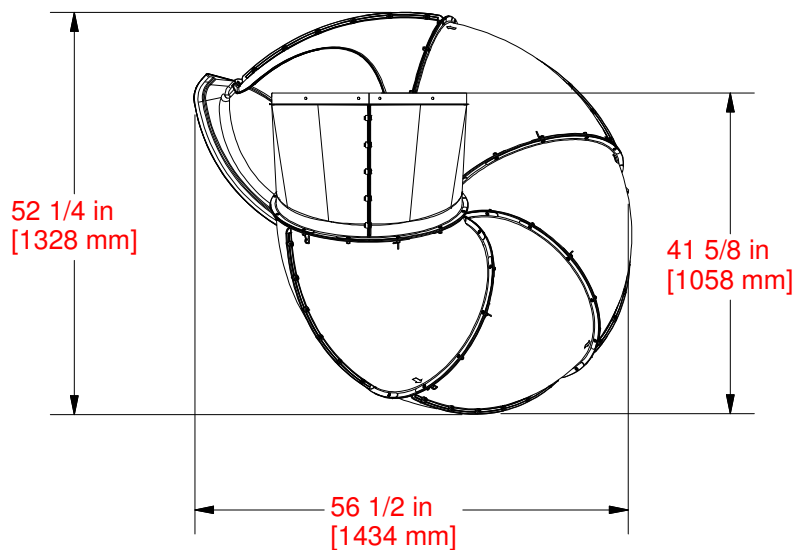

Owner's Manual - Parts Identification

Wood Components (Not to Scale)

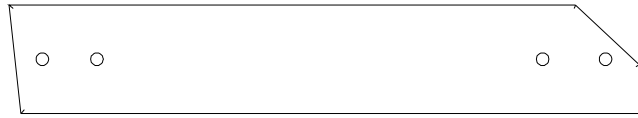

E85 UPRIGHT - W4L12970
(x1) 1 3/8"x3 3/8"x19 7/8" (36x86x505)



E86 UPRIGHT - W4L12971
(x1) 1 3/8"x3 3/8"x24 1/2" (36x86x623)

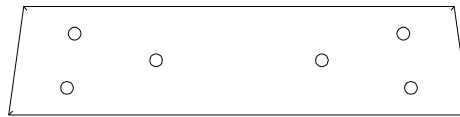

E87 GROUND BOARD - W4L12969
(x1) 1 3/8"x3 3/8"x14 3/8" (36x86x366)

Owner's Manual - Parts Identification

Hardware Components

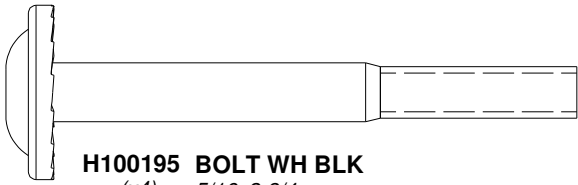

H100195 BOLT WH BLK
(x4) 5/16x2-3/4

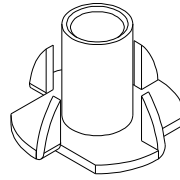

H100379 T-NUT BLK
(x8) 5/16

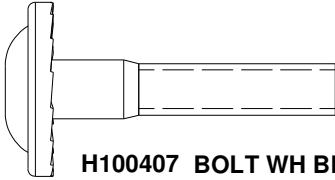

H100407 BOLT WH BLK
(x4) 5/16x1 1/2

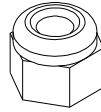

H100148 NUT LOCK WZ
(x115) 1/4

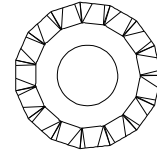

**H100198 WASHER LOCK
EXT BLK**
(x4) 8x19

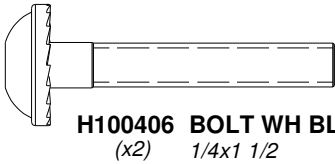

H100406 BOLT WH BLK
(x2) 1/4x1 1/2

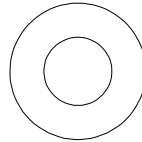

H100474 WASHER FLAT BLK
(x2) 9x18

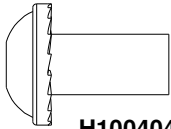

H100404 NUT BARREL WH BLK
(x2) 1/4x5/8

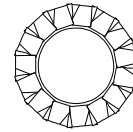

**H100400 WASHER LOCK
EXT BLK**
(x2) 8x15

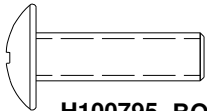

H100795 BOLT PTH WZ
(x2) 1/4x7/8

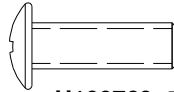

H100769 BOLT PTH WZ
(x113) 1/4x3/4

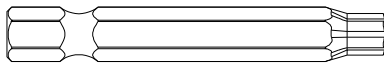

H100147 T-30 TORX BIT
(x1)

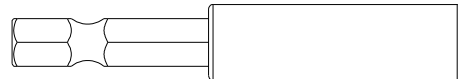

H101100 MAGNETIC DRIVER
(x1)

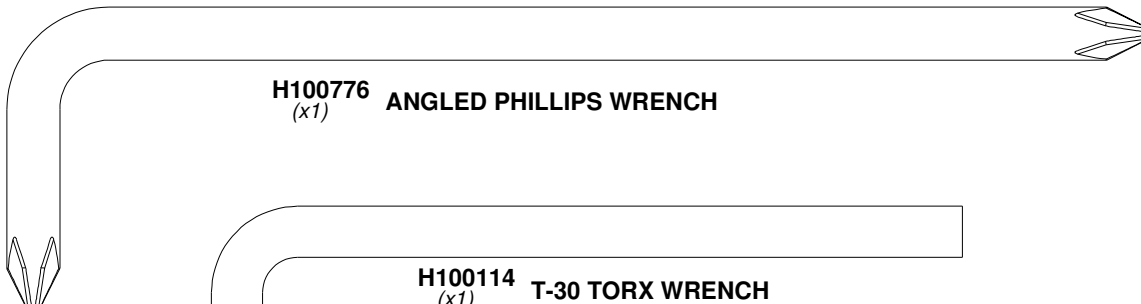

H100776 ANGLED PHILLIPS WRENCH
(x1)

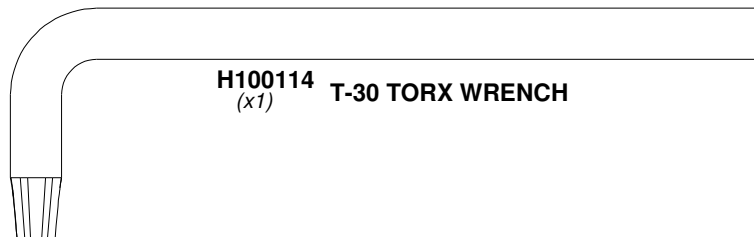

H100114 T-30 TORX WRENCH
(x1)

Owner's Manual - Parts Identification

Accessory Components (Not to Scale)

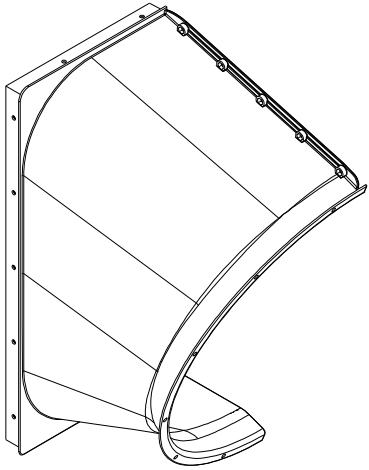

A6P00302-2
(x1) **SLIDE ENTRANCE LEFT**

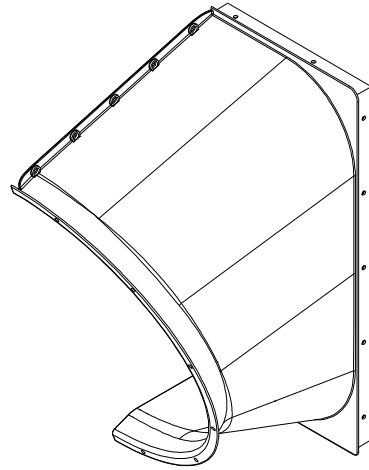

A6P00302-1
(x1) **SLIDE ENTRANCE RIGHT**

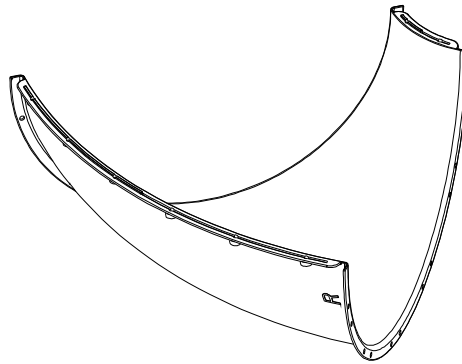

A6P00302-4
(x9) **SLIDE ELBOW**

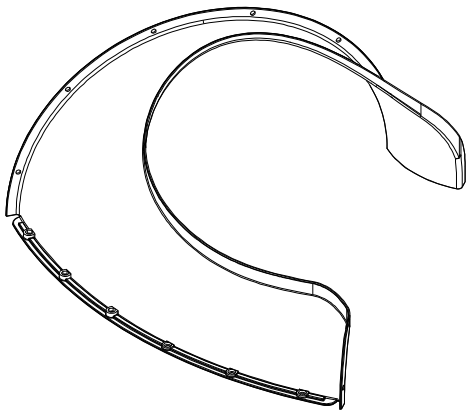

A6P00302-5R
(x1) **EXIT TOP**

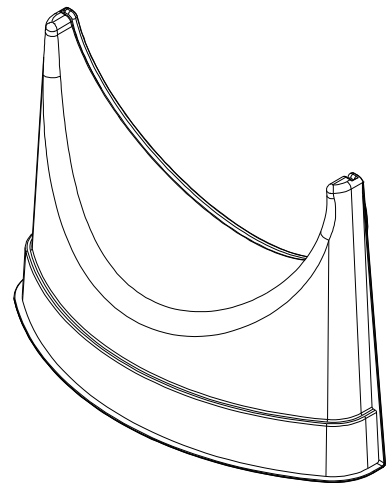

A6P00302-6R
(x1) **EXIT SUPPORT**

Owner's Manual - Parts Identification

Accessory Components (Not to Scale)



A100178
(x2) **AUGER GROUND STAKE**

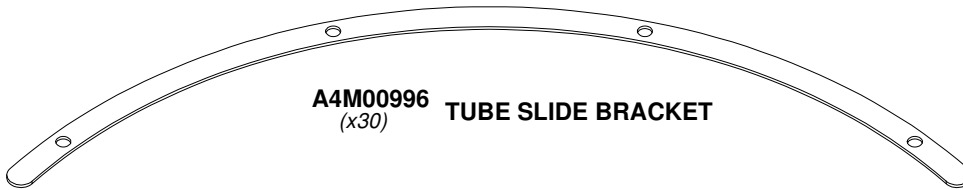

A4M00996
(x30) **TUBE SLIDE BRACKET**

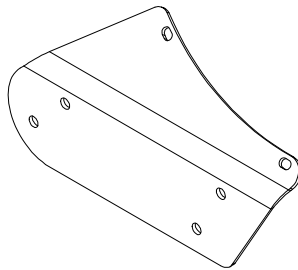

A4M01087
(x1) **TUBE SLIDE BRACKET - RH**

PRE-ASSEMBLY STEP 1 - SORTING PARTS

It is critical for ease of assembly that you take the time to sort and organize the wood and hardware.

WOOD PARTS:

- Organize wood parts by the three-digit, alpha-numeric number stamped on each board (ex. P01).
- If there are multiple boards with the same stamped number, stack those pieces together.
- Stamps can be found on the flat surface of the boards or on the end of the boards.
- Allow yourself plenty of room - the wood pieces can take up a significant amount of space.

NOTE: CARTONS ARE NOT ORGANIZED BY BOARD NUMBER.

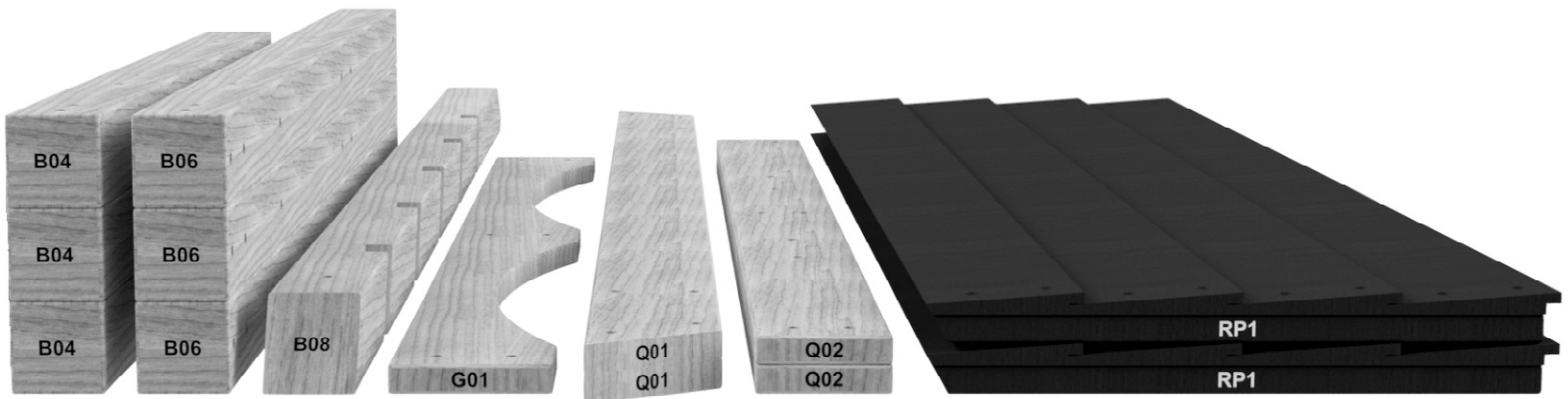

HARDWARE PARTS:

- We recommend that you have a separate table to organize the hardware.
- Hardware bags are printed with a seven-digit, alpha-numeric part number.
- You can organize your hardware by part number or group by hardware type (i.e. bolts, nuts, etc.).
- During assembly you only need to reference the last four digits of the number.

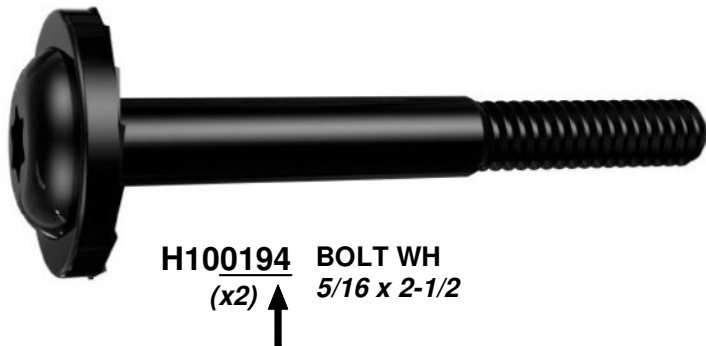

PRE-ASSEMBLY STEP 2 - TOOLS REQUIRED



**Cordless Drill or
Electric Drill**



**Drill Attachments:
Phillips Head**



**1/8", 3/16", 3/8" & 7/16"
Drill Bits**



Phillips Screw Driver



Open End Wrenches 1/2" & 9/16"



**3/8" Drive Ratchet, 1/2" &
9/16" STD Sockets 1/2" & 9/16" Deep
Sockets**



Claw Hammer



Rubber Mallet - Optional



Tape Measure

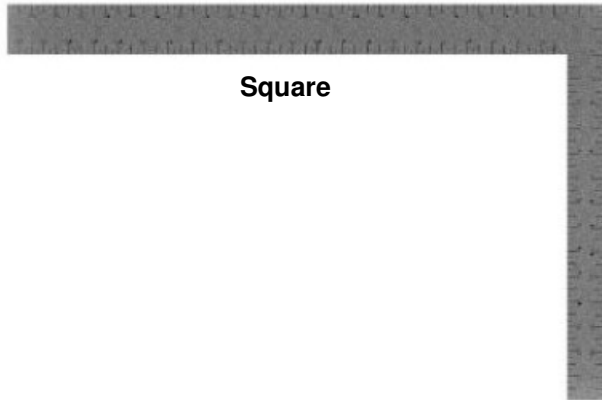

Square





Level 24"

PRE-ASSEMBLY STEP 3 - CHOOSE YOUR ASSEMBLY METHOD



There are several types of assembly instructions available to you.

1. Printed Assembly Manual included with your set
2. BILT APP - 3D interactive instructions
3. Combination of the Printed Manual and BILT APP (Note: Step numbers can differ between the two methods)

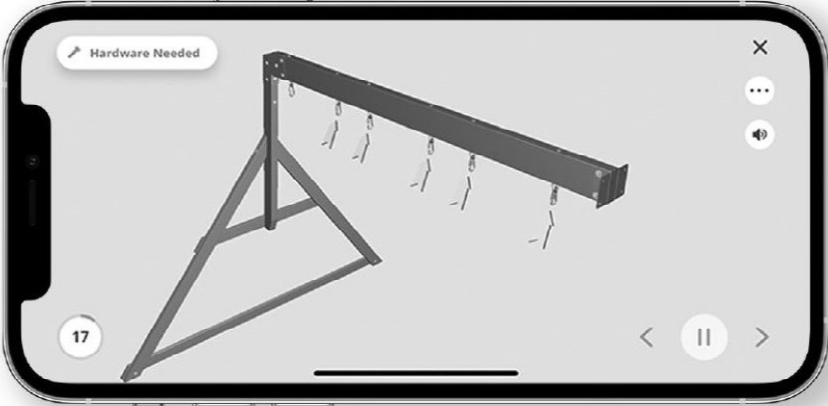

Scan for easy 3D instructions

Download the BILT app
before you begin



The image shows a smartphone screen displaying the BILT app interface. At the top left, there is a tab labeled "Hardware Needed". The main area of the screen shows a 3D perspective view of a metal frame structure with several bolts and nuts being attached to a horizontal beam. In the bottom left corner of the app interface, the number "17" is displayed in a white circle. In the bottom right corner, there are navigation icons: a back arrow, a pause button, and a forward arrow. The entire advertisement is enclosed in a thick grey border.

STEP 1 - SLIDE ASSEMBLY

QTY	PART NUMBER	DESCRIPTION
8	H100148	NUT LOCK 1/4"
8	H100769	BOLT PTH 1/4x3/4"

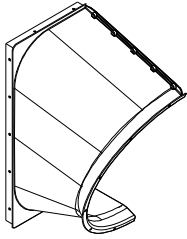

A6P00302-2
(x1) **SLIDE ENTRANCE LEFT**

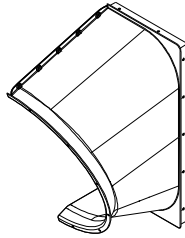

A6P00302-1
(x1) **SLIDE ENTRANCE RIGHT**

TIP:
LAYING THE PARTS ON THEIR FLAT END
MAKES ASSEMBLY EASIER.

148 (x8)
NUT - 1/4"

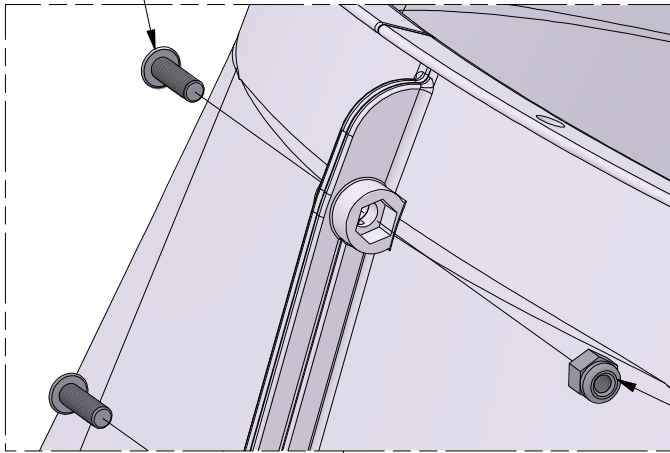

769 (x8)
BOLT - 3/4"

302-1 (x1)
SLIDE ENTRANCE RIGHT

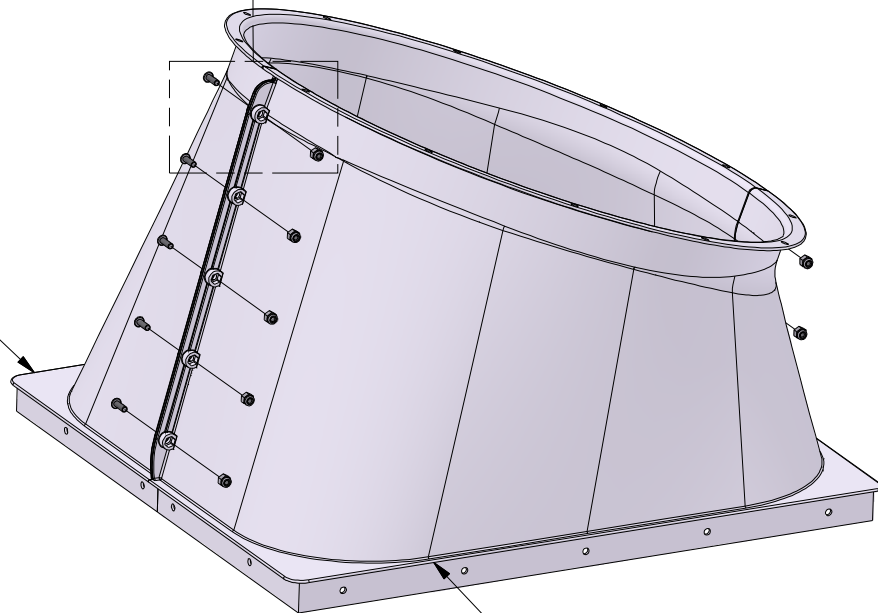

302-2 (x1)
SLIDE ENTRANCE LEFT

STEP 2 - SLIDE ASSEMBLY

QTY	PART NUMBER	DESCRIPTION
32	H100148	NUT LOCK 1/4"
32	H100769	BOLT PTH 1/4x3/4

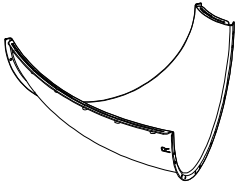

A6P00302-4
(x8) SLIDE ELBOW

NOTE:
REPEAT THIS STEP (3) MORE TIMES.

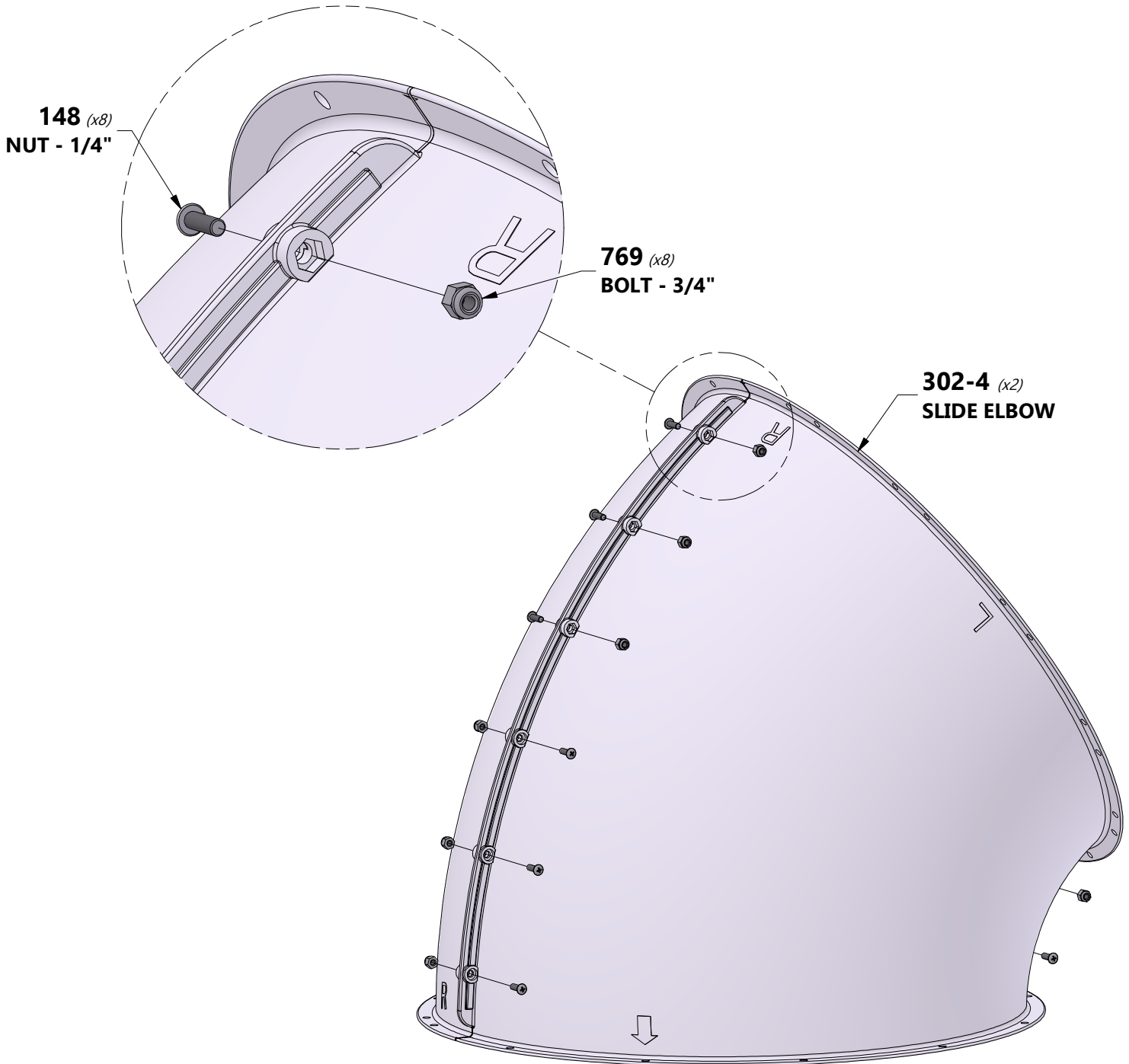

STEP 3 - SLIDE ASSEMBLY

QTY	PART NUMBER	DESCRIPTION
8	H100148	NUT LOCK 1/4
8	H100769	BOLT PTH 1/4x3/4

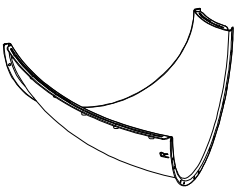

A6P00302-4
(x1) SLIDE ELBOW

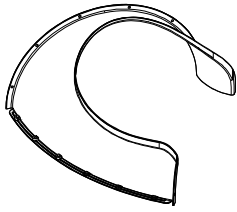

A6P00302-5R
(x1) EXIT TOP

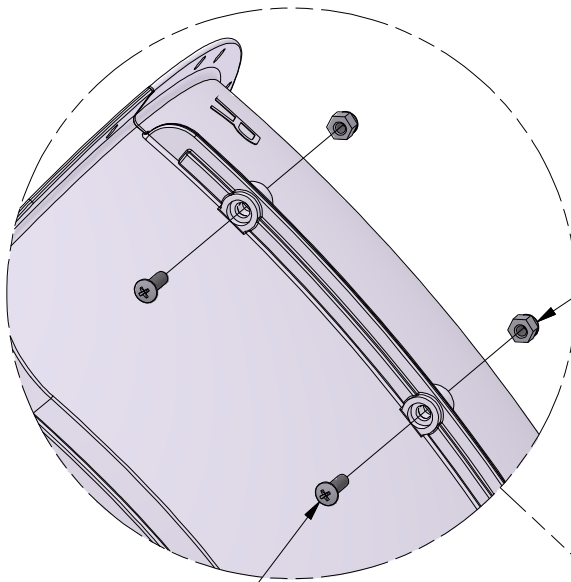

474 *(x8)*
WASHER - 9x18

769 *(x8)*
BOLT - 3/4"

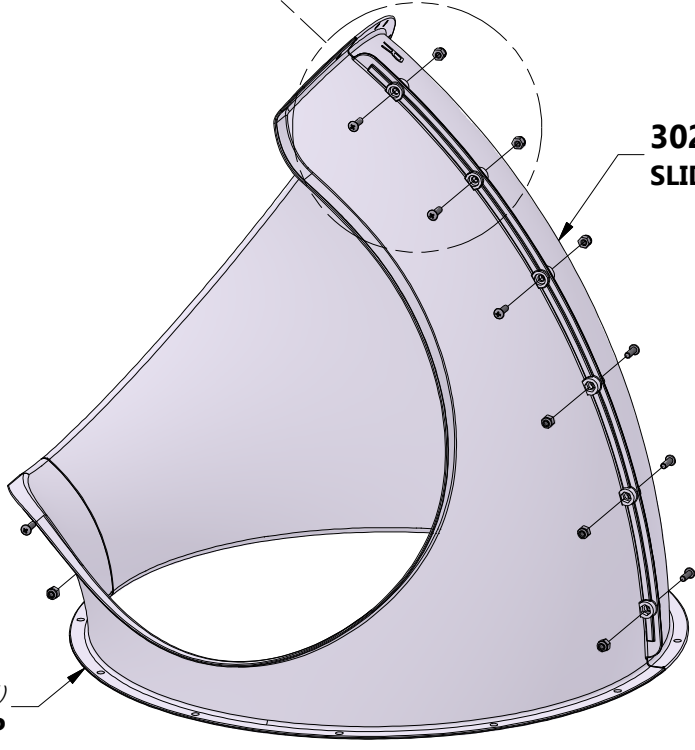

302-4 *(x1)*
SLIDE ELBOW

302-5R *(x1)*
EXIT TOP

STEP 4 - SLIDE ASSEMBLY

QTY	PART NUMBER	DESCRIPTION
5	H100148	NUT LOCK 1/4"
7	H100769	BOLT PTH 1/4x3/4"

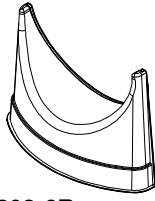

A6P00302-6R
(x1) EXIT SUPPORT

- **RECOMMENDED BOLT ASSEMBLY ORDER, FROM TOP LEFT AS YOU ALIGN HOLES.**
- **MAKE SURE THE EXIT SUPPORT IS ALIGNED WITH THE SLIDE ELBOW AS SHOWN BELOW.**
- **USE A SCREW DRIVER TO ALIGN HOLES.**
- **WHEN REMOVING SPACER, BEGIN ALIGNMENT OF TUBE SLIDE OPENING FOR EASIER ASSEMBLY.**

FRONT VIEW

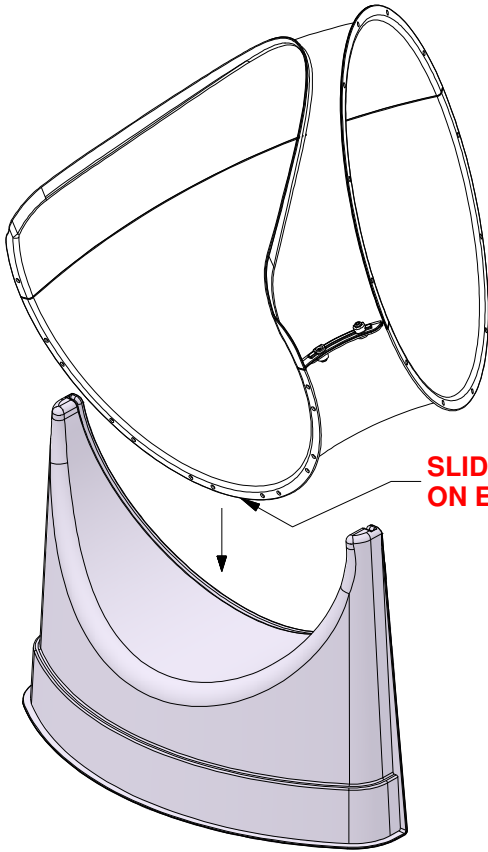

**SLIDE INTO GROOVE
ON EXIT SUPPORT.**

TUBE SLIDE SPACER

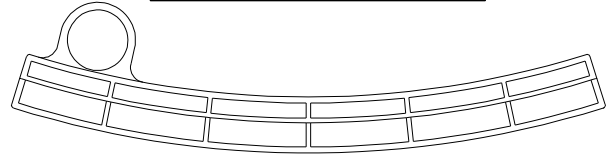

**START ALIGNMENT
OF HOLES FROM
THE TOP LEFT.**

**FACTORY INSTALLED
NUT. (BOTH CORNERS)**

**302-6R *(x1)*
EXIT SUPPORT**

**769 *(x7)*
BOLT - 3/4"**

**148 *(x5)*
NUT - 1/4"**

BACK VIEW

REFERENCE

IMPORTANT: BRACKET CONFIGURATION ASSEMBLY & PLACEMENT.

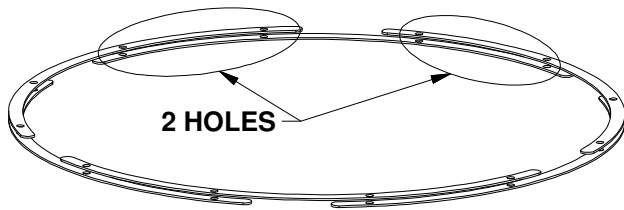

CONFIGURATION 'A' DIAGRAM

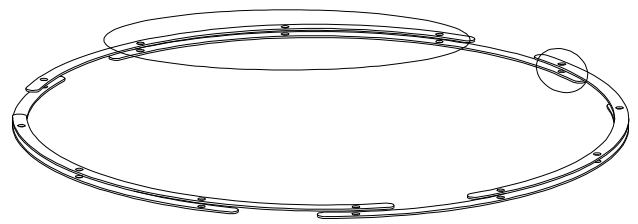

CONFIGURATION 'B' DIAGRAM

TIP:
PAY CLOSE ATTENTION TO THE ALIGNMENT MARKINGS ON EACH SLIDE SECTION. THE MARKINGS WILL AID YOU IN POSITIONING THE METAL SLIDE BRACKETS CORRECTLY.

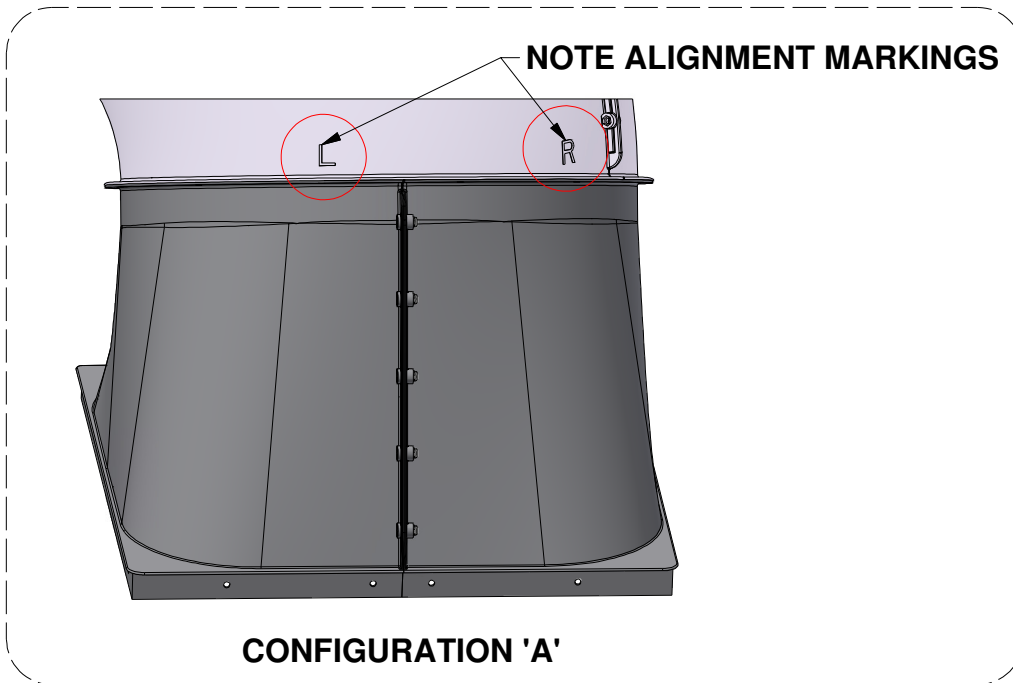

CONFIGURATION 'A'

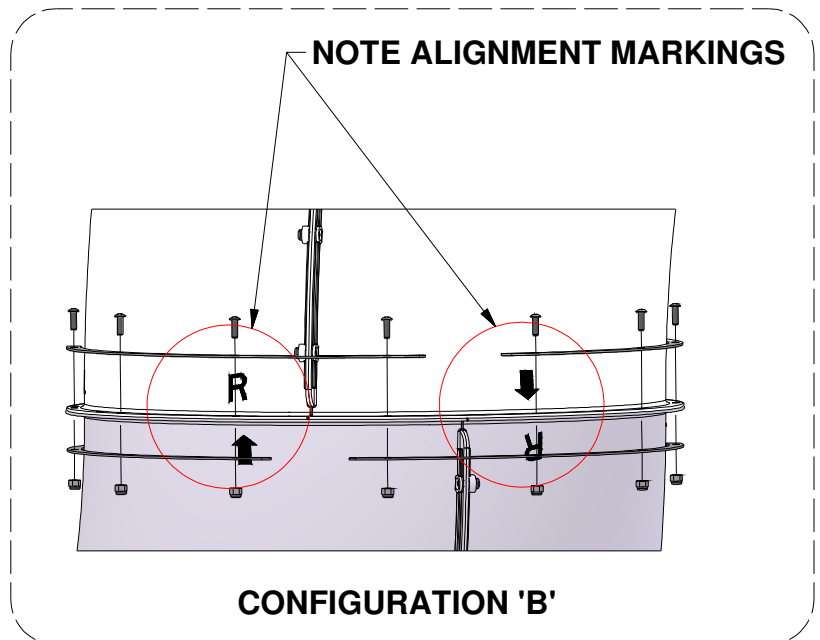

CONFIGURATION 'B'

STEP 5 - SLIDE ASSEMBLY

QTY	PART NUMBER	DESCRIPTION
12	H100148	NUT LOCK 1/4
12	H100769	BOLT PTH 1/4x3/4

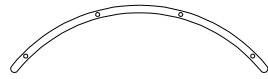

A4M00996
(x6) **TUBE SLIDE BRACKET**

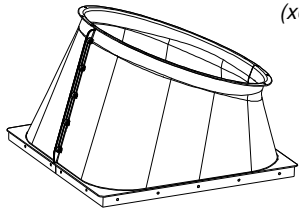

ENTRANCE SUB-ASSEMBLY

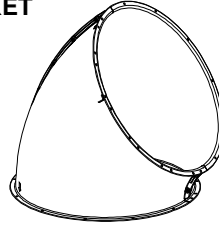

ELBOW TUBE SUB-ASSEMBLY

TIP:
USE A SCREW DRIVER TO ALIGN HOLES.

**THIS SECTION ASSEMBLY USES
BRACKET CONFIGURATION 'A'
SHOWN ON REFERENCE PAGE.**

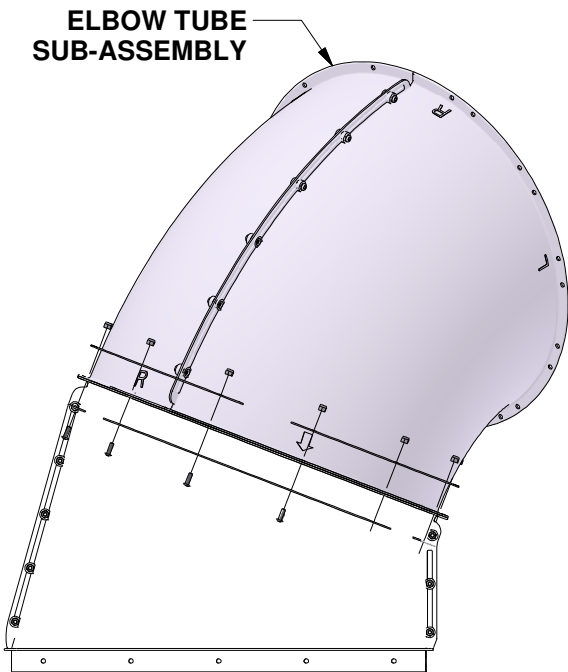
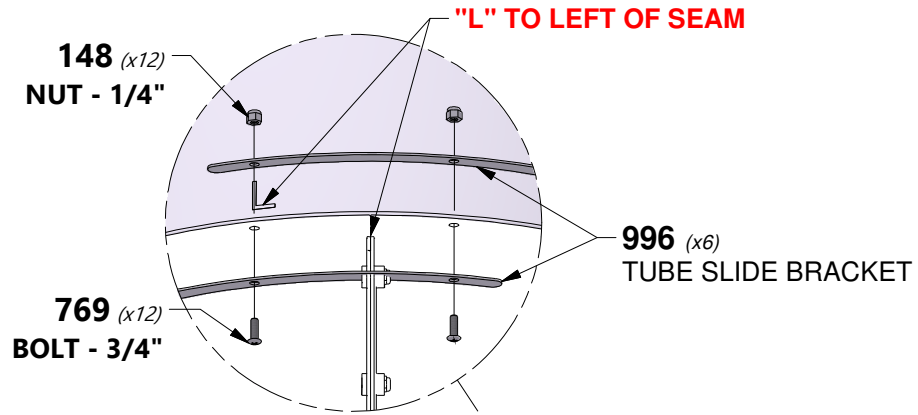

LEFT SIDE VIEW

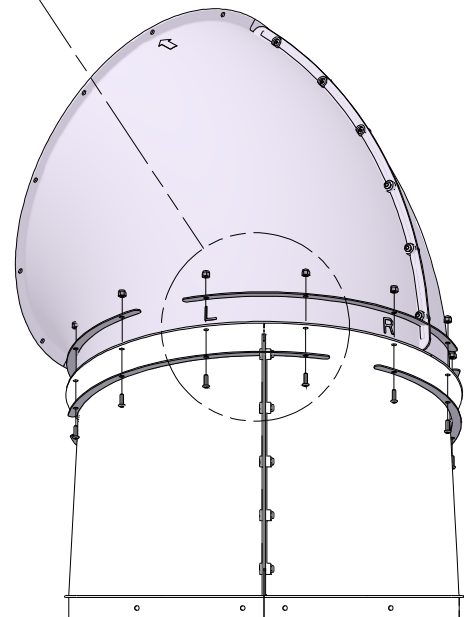

TOP VIEW

STEP 6 - SLIDE ASSEMBLY

QTY	PART NUMBER	DESCRIPTION
12	H100148	NUT LOCK 1/4
12	H100769	BOLT PTH 1/4x3/4



ELBOW TUBE SUB-ASSEMBLY

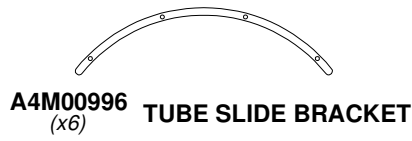

- ALIGN THE 'R' AND THE 'ARROW' TO ACHIEVE THE PROPER POSITION WHEN ASSEMBLING THE SLIDE.
- NOTE THIS SECTION ASSEMBLY USES CONFIGURATION 'B' SHOWN ON THE REFERENCE PAGE.

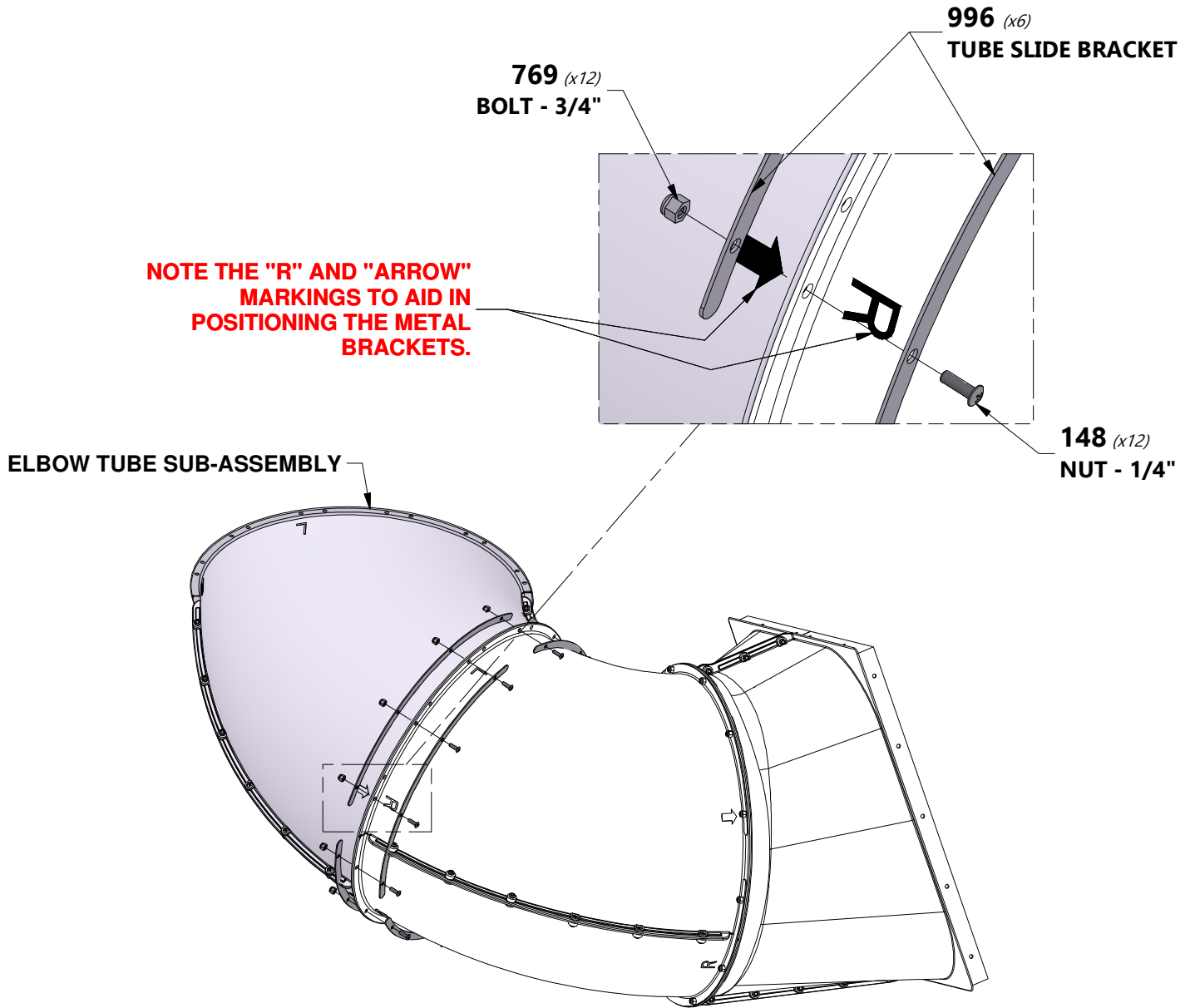

STEP 7 - SLIDE ASSEMBLY

QTY	PART NUMBER	DESCRIPTION
12	H100148	NUT LOCK 1/4
12	H100769	BOLT PTH 1/4x3/4



ELBOW TUBE SUB-ASSEMBLY

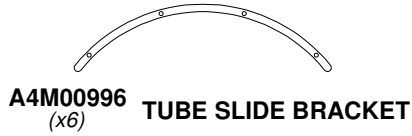

- ALIGN THE 'R' AND THE 'ARROW' TO ACHIEVE THE PROPER POSITION WHEN ASSEMBLING THE SLIDE.
- NOTE THIS SECTION ASSEMBLY USES CONFIGURATION 'B' SHOWN ON THE REFERENCE PAGE.

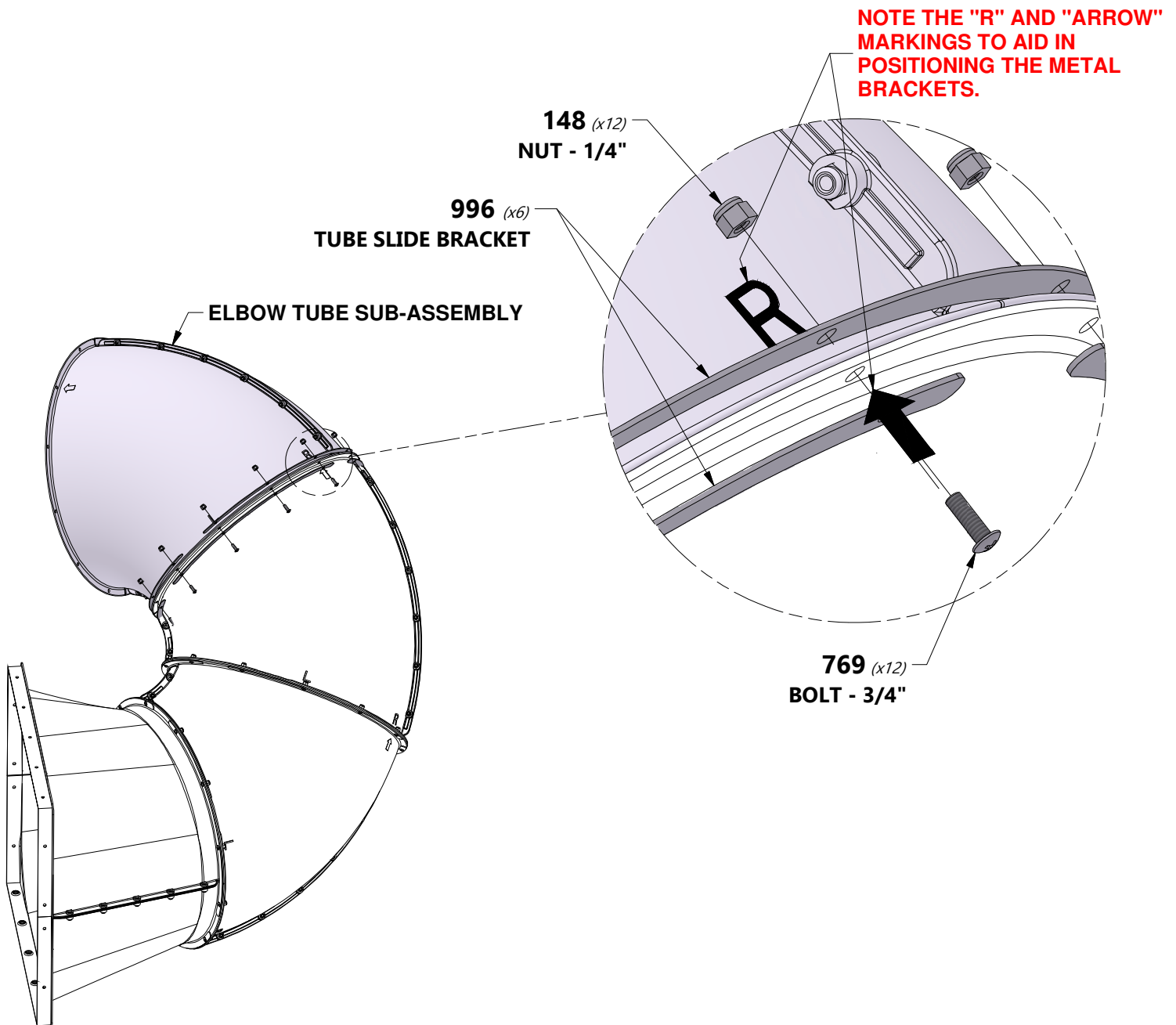

STEP 8 - SLIDE ASSEMBLY

QTY	PART NUMBER	DESCRIPTION
12	H100148	NUT LOCK 1/4
10	H100769	BOLT PTH 1/4x3/4
2	H100795	BOLT PTH 1/4x7/8

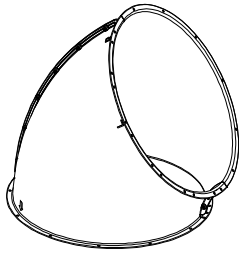

ELBOW TUBE SUB-ASSEMBLY

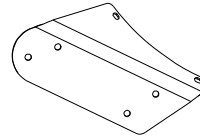
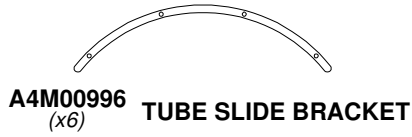

- **ALIGN THE 'R' AND THE 'ARROW' TO ACHIEVE THE PROPER POSITION WHEN ASSEMBLING THE SLIDE.**
- **NOTE THIS SECTION ASSEMBLY USES CONFIGURATION 'B' SHOWN IN THE REFERENCE PAGE.**
- **NOTE THE BOLTS USED TO ASSEMBLE THE SLIDE BRACKET ARE 7/8", NOT 3/4".**

NOTE THE "R" AND "ARROW" MARKINGS TO AID IN POSITIONING THE METAL BRACKETS.

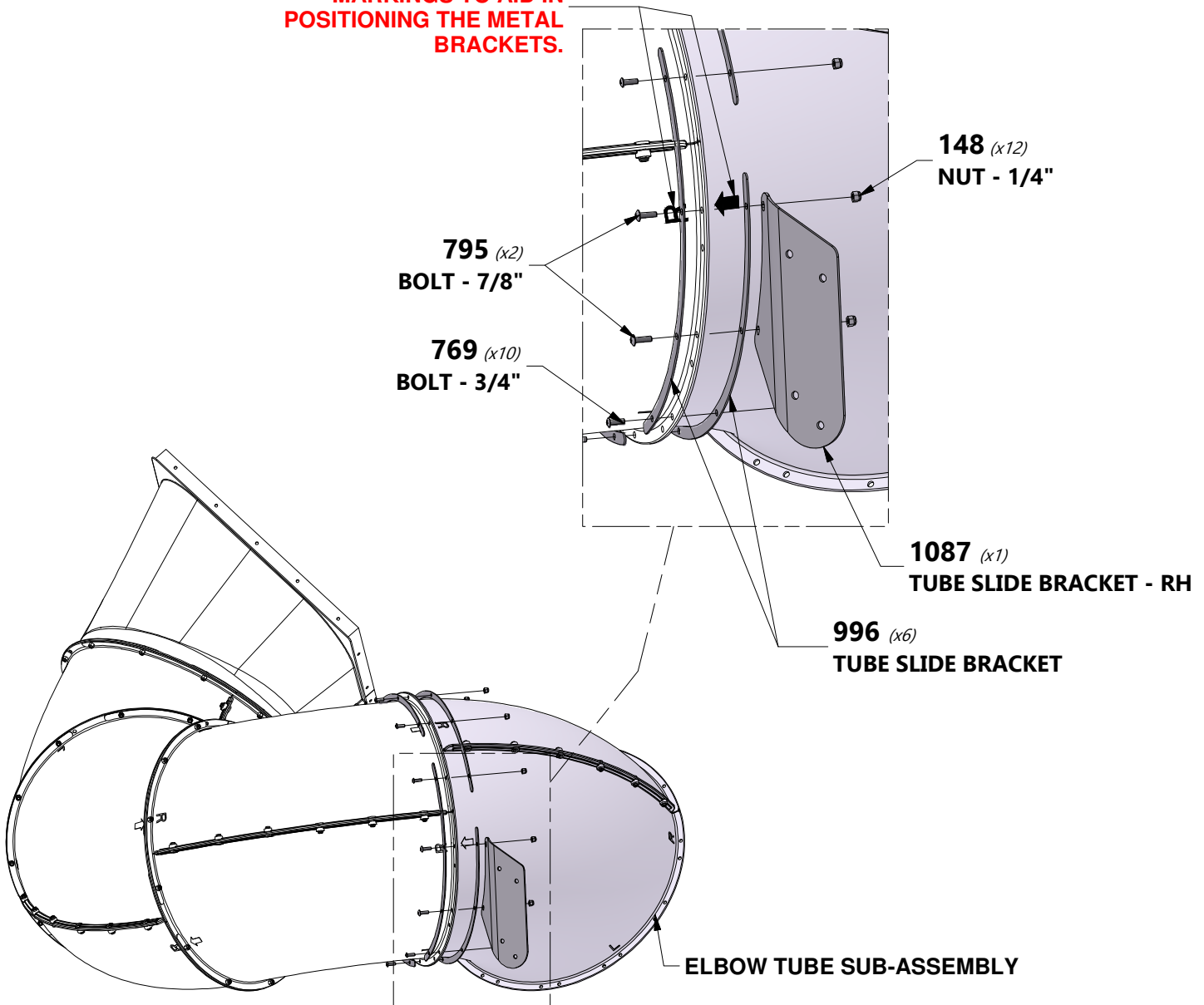

STEP 9 - SLIDE ASSEMBLY

QTY	PART NUMBER	DESCRIPTION
12	H100148	NUT LOCK 1/4
12	H100769	BOLT PTH 1/4x3/4

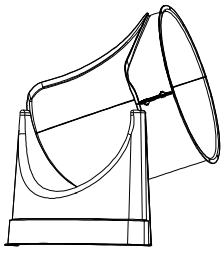

EXIT SUB-ASSEMBLY

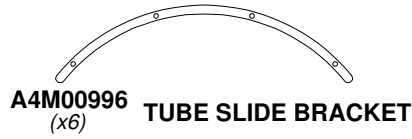

- ALIGN THE 'L' AND THE 'ARROW' TO ACHIEVE THE PROPER POSITION WHEN ASSEMBLING THE SLIDE.
- NOTE THIS SECTION ASSEMBLY USES CONFIGURATION 'B' SHOWN IN THE REFERENCE PAGE.

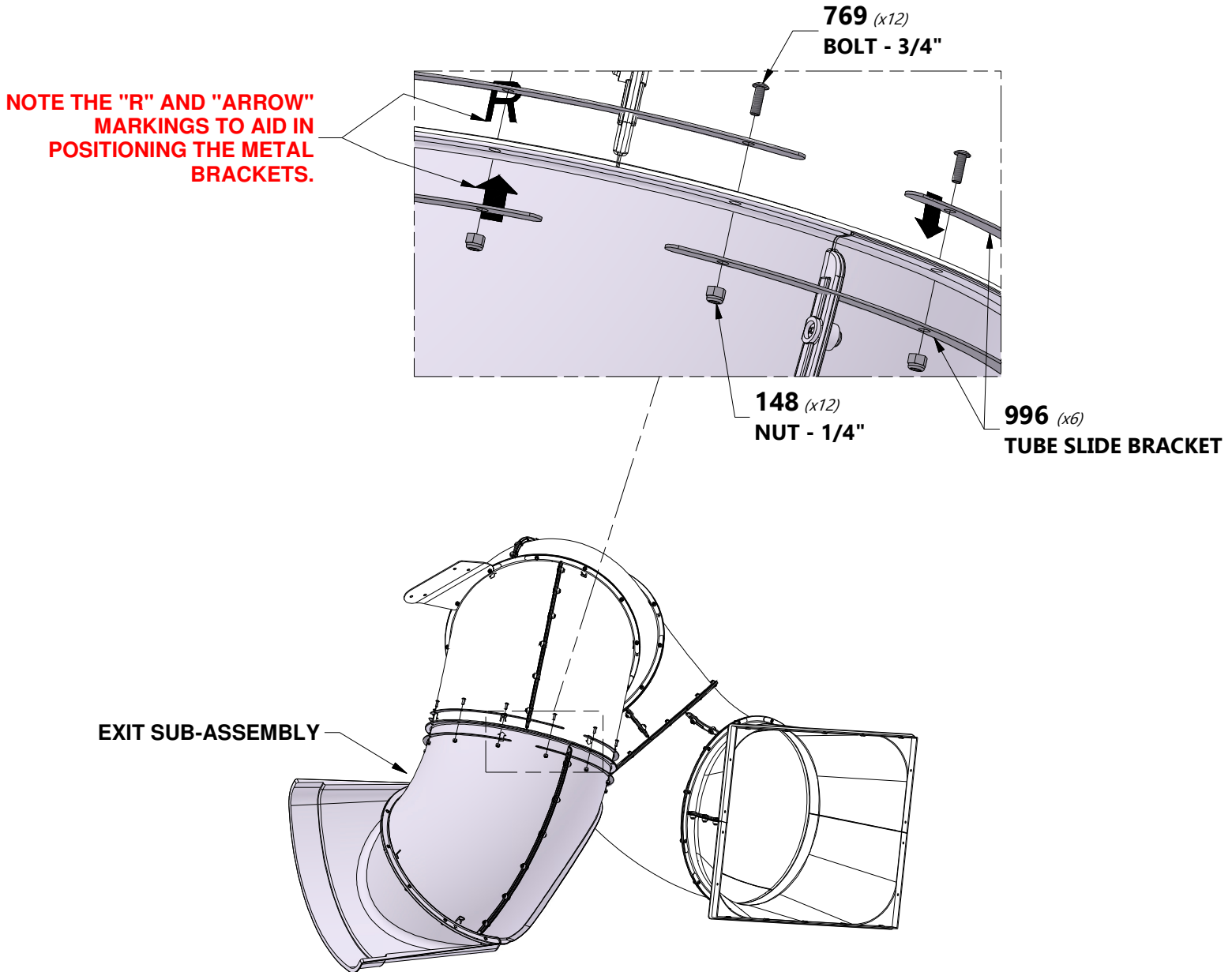

STEP 10 - SLIDE ASSEMBLY

QTY	PART NUMBER	DESCRIPTION
4	H100195	BOLT WH 5/16x2 3/4 BLK
4	H100198	WASHER LOCK EXT 8x19 BLK
4	H100379	T-NUT 5/16 BLK



E85 UPRIGHT - W4L12970
(x1) 1 3/8"x3 3/8"x19 7/8" (36x86x505)



E87 GROUND BOARD - W4L12969
(x1) 1 3/8"x3 3/8"x14 3/8" (36x86x366)



E86 UPRIGHT - W4L12971
(x1) 1 3/8"x3 3/8"x24 1/2" (36x86x623)

TIP:
INSTALL T-NUTS IN WOOD FIRST

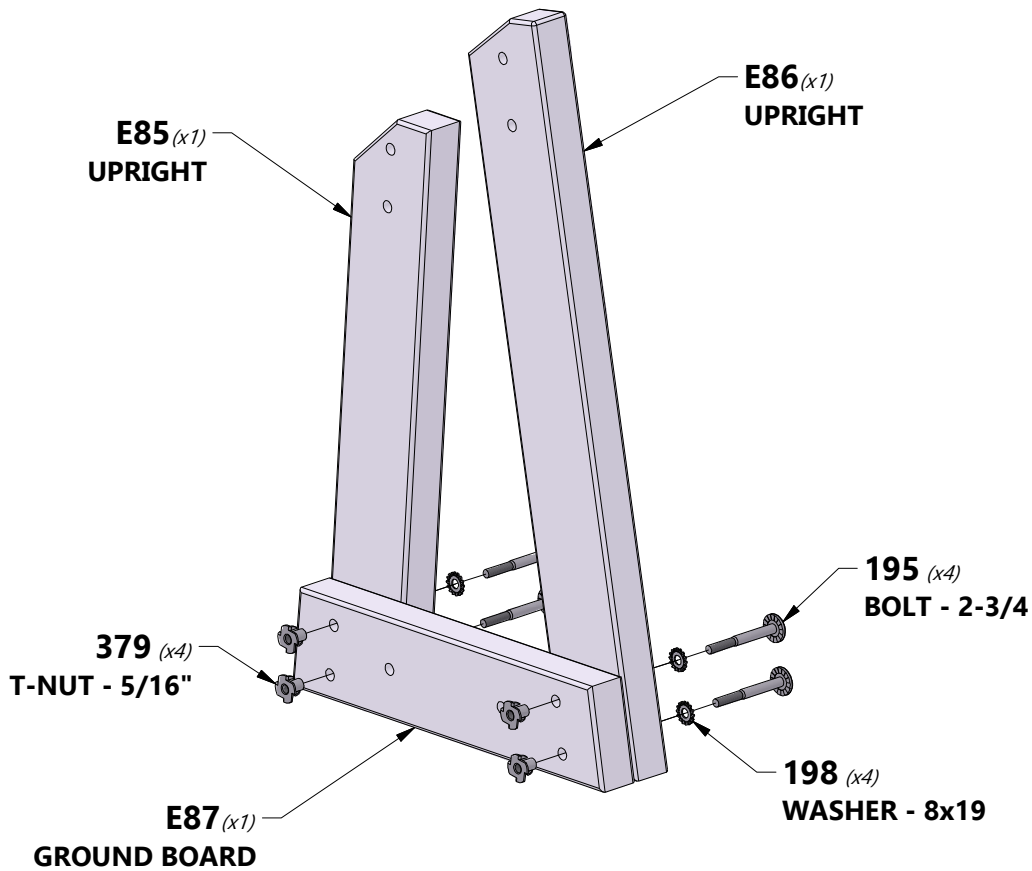

STEP 11 - SLIDE ASSEMBLY

QTY	PART NUMBER	DESCRIPTION
4	H100379	T-NUT 5/16 BLK
4	H100407	BOLT WH 5/16x1 1/2 BLK

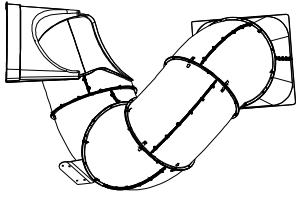

TUBE SLIDE SUB-ASSEMBLY

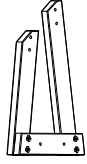

SLIDE BRACE SUB-ASSEMBLY

TIP:
INSTALL T-NUTS IN WOOD FIRST

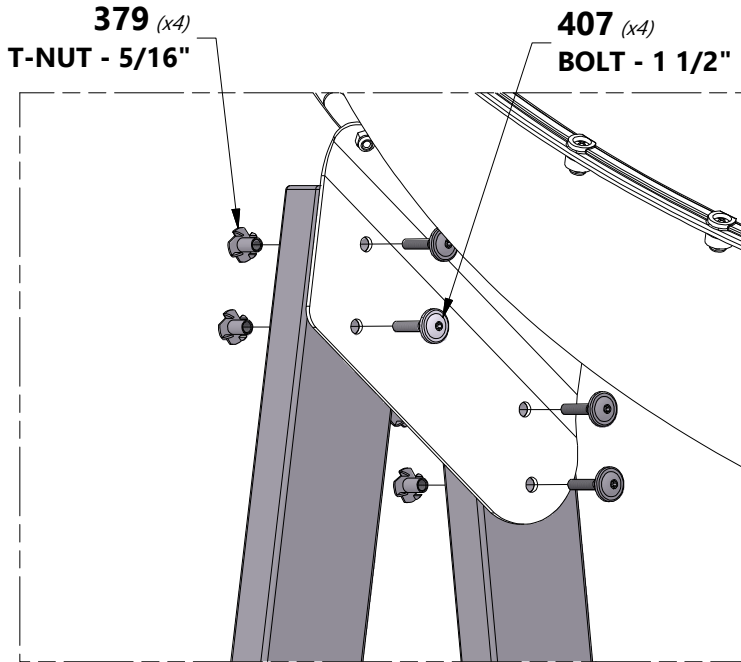

TUBE SLIDE SUB-ASSEMBLY

SLIDE BRACE SUB-ASSEMBLY

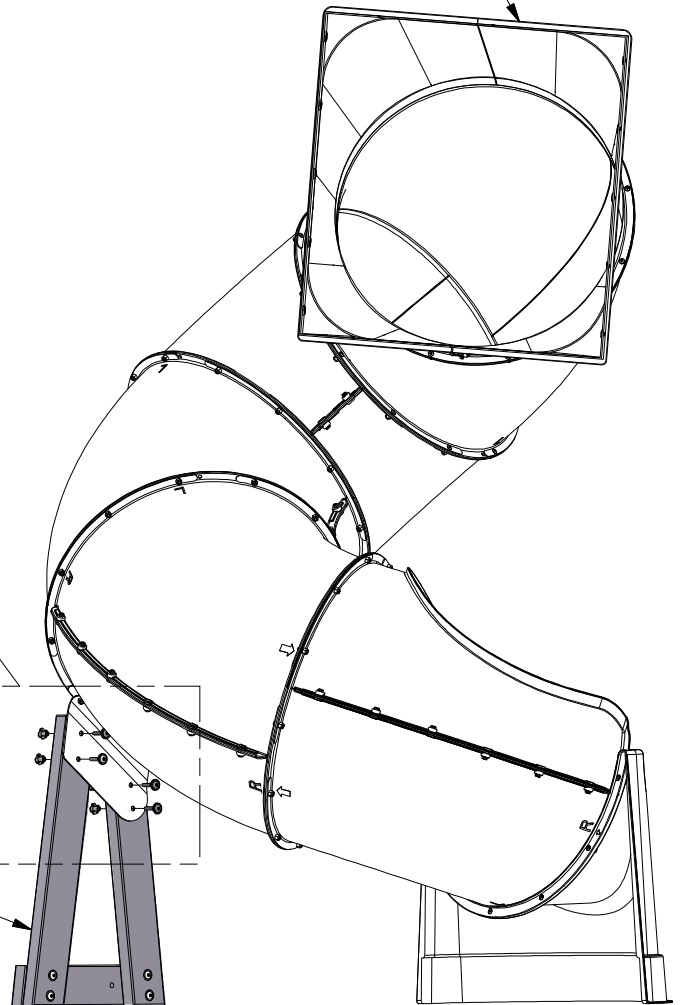

STEP 12 - SLIDE ASSEMBLY

QTY	PART NUMBER	DESCRIPTION
2	H100400	WASHER LOCK 8x15 BLK
2	H100404	NUT BARREL 1/4x5/8 BLK
2	H100406	BOLT WH 1/4x1 1/2 BLK
2	H100474	WASHER FLAT 9x18 BLK



A100178
(x2) **AUGER GROUND STAKE**

TWIST GROUND STAKE INTO GROUND AT LOCATIONS SHOWN.

