

RANGE
OUTDOOR LIVING

Manufactured by:
Range Outdoor Living
3305 Airport Drive, Pittsburg, KS 66762
800-856-4445

Basepoint Business Centre: Rivermead Drive, Westlea, Swindon SN5 7EX Phone: 0800-118-2476
J.P. Coenstraat 7, The Bridge, The Hague, 2595 WP, Netherlands Phone: 08005678990

19x14 LODGE GAZEBO

MODEL # : 2506084



WARNING

Cancer and Reproductive Harm
www.P65Warnings.ca.gov



Please visit www.rangeoutdoorliving.com
For the most up to date assembly manual, to register your product, or to order
replacement parts *Para obtener instrucciones en español, visite*
www.rangeoutdoorliving.com



EASY STEP-BY-STEP
3D INTERACTIVE INSTRUCTIONS
DOWNLOAD THE FREE APP



OWNER'S MANUAL - BASIC SETUP DIMENSIONS & ASSEMBLY NOTES

It is critically important that you start with square and level footings or concrete pad to attach your structure

- Pay close attention to the items needed for each step. Make sure you are using the correct hardware for each step. Using incorrect hardware may result in improper assembly
- Remember to double check for underground utilities and overhead electrical lines

Post mounts are provided with your structure which allows you to permanently install your structure to a pre-existing or new wood or concrete surface. See Anchor Instructions for further details and recommendations.

- The hardware to attach the post mounts to the structure is included.
- The hardware to mount the structure permanently to a concrete surface is included.
- The hardware to mount the structure permanently to a wood deck is NOT included and will need to be purchased separately. You must ensure there is ample structural support under the deck before permanently attaching.

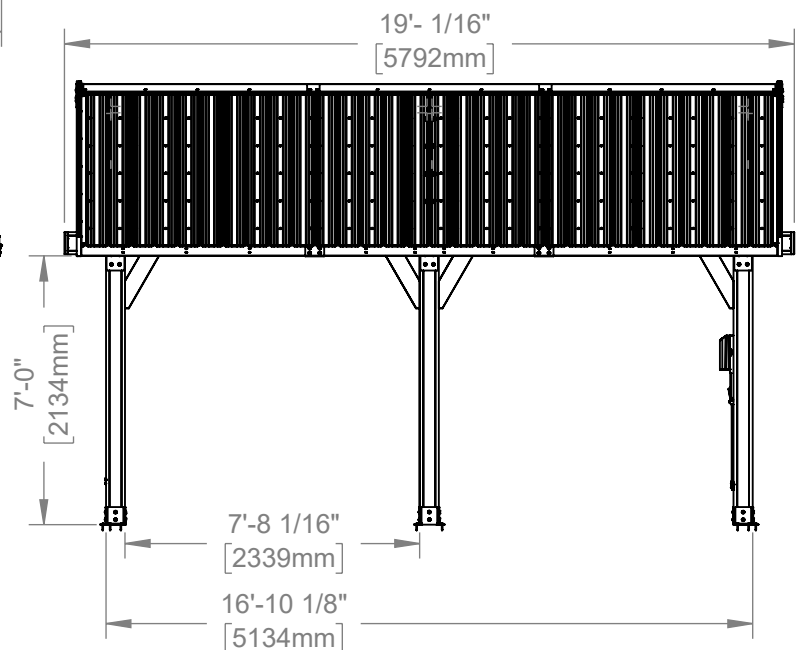
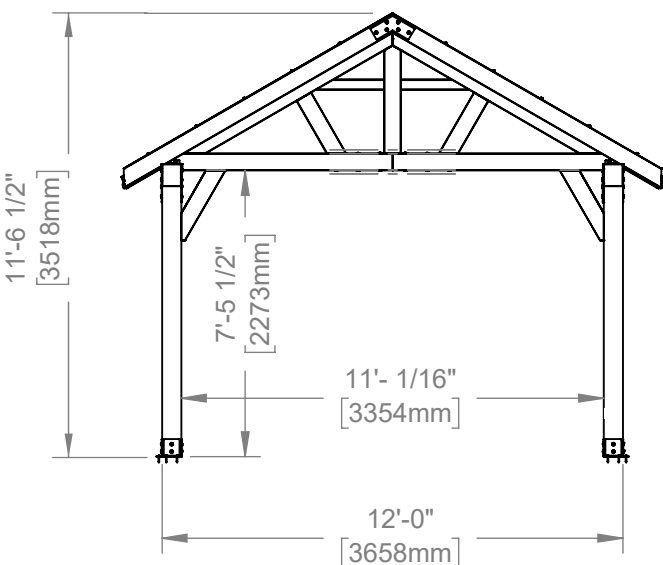
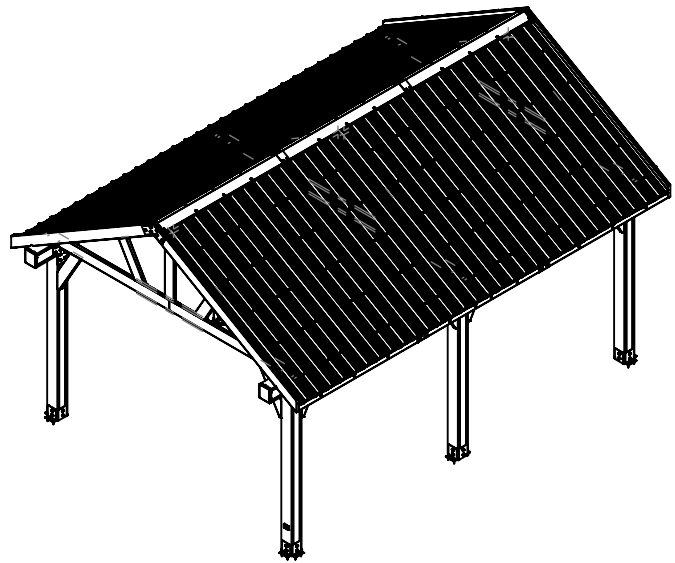
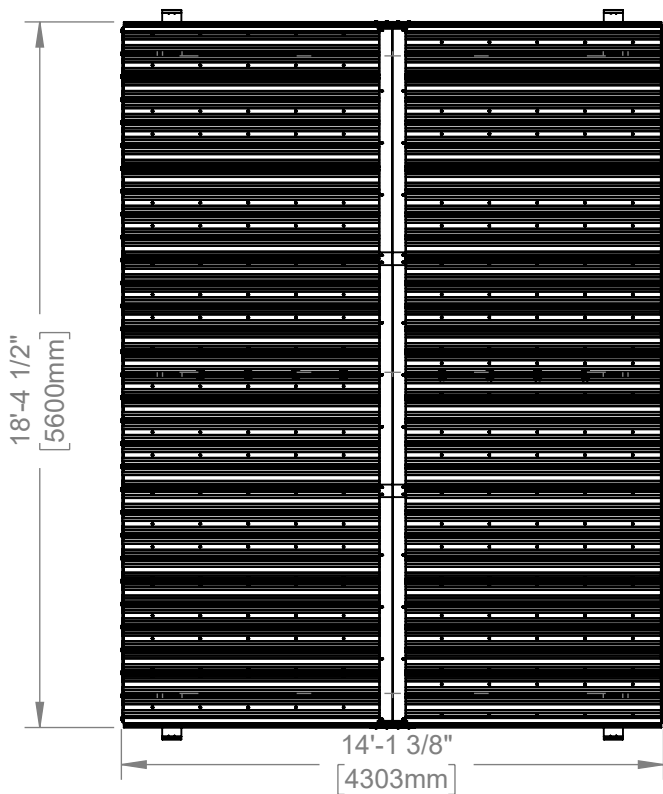

OWNER'S MANUAL - ANCHORING LAYOUT

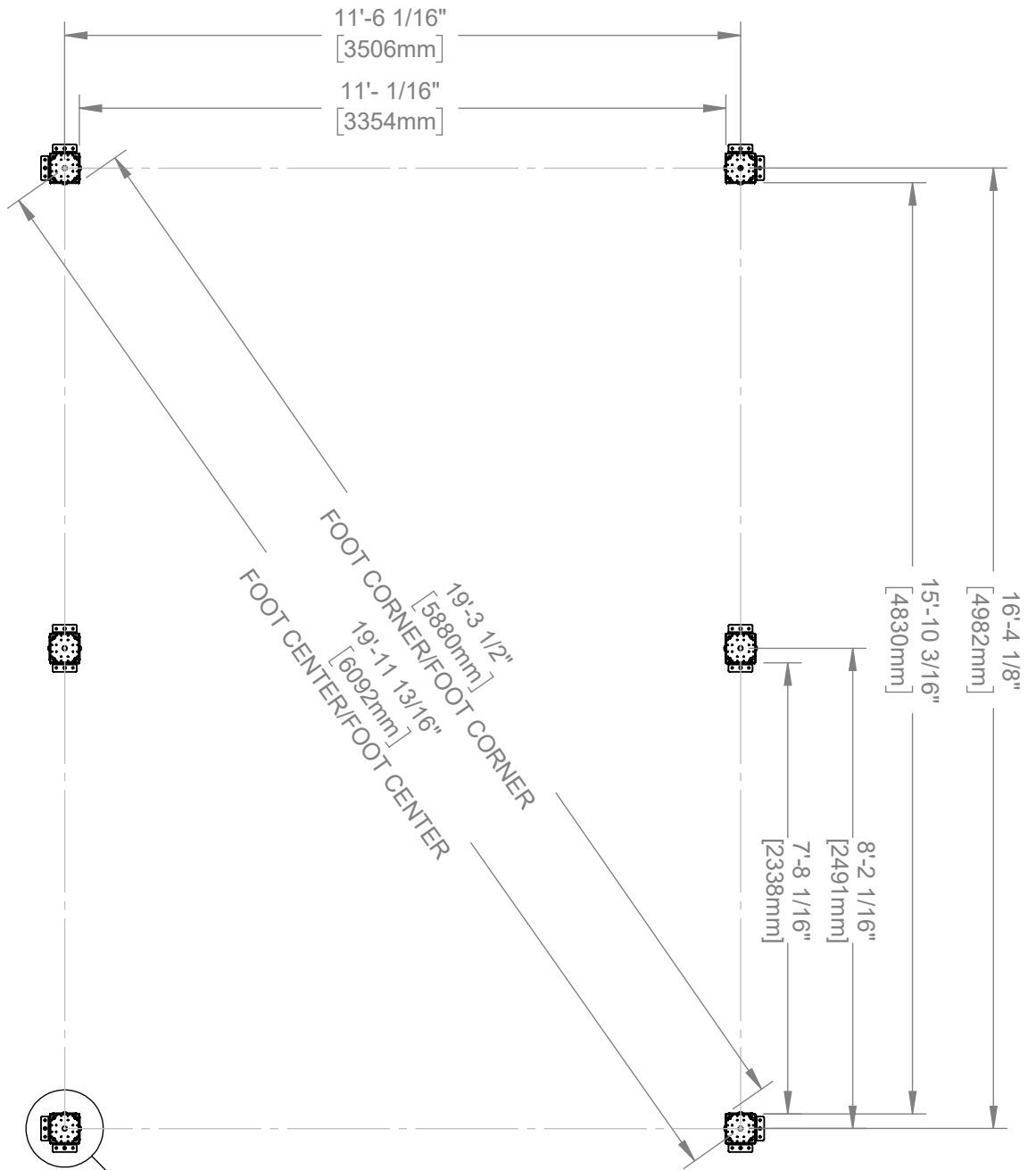

NOTE: DIMENSIONS ARE TO ANCHOR PLATES MOUNTED TO POSTS EXCEPT WHERE NOTED.

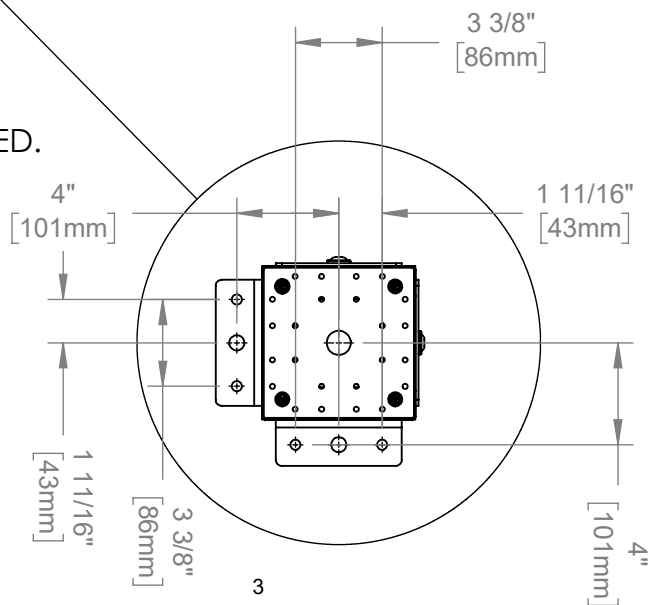

OWNER'S MANUAL - PARTS IDENTIFICATIONS

WOOD COMPONENTS (NOT TO SCALE)

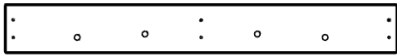

AD01 RIDGE SUPPORT - W4L22008
(x2) 15/16"x4"x31 15/16" (24x102x812)

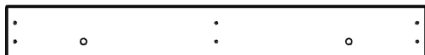

AD06 RIDGE SUPPORT - W4L22011
(x2) 15/16"x4"x31 15/16" (24x102x812)

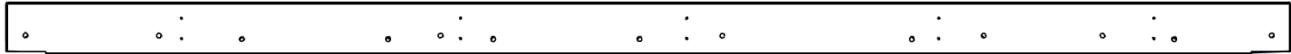

AD02 PEAK SUPPORT - W4L22014
(x2) 15/16"x4"x98 13/16" (24x102x2510)

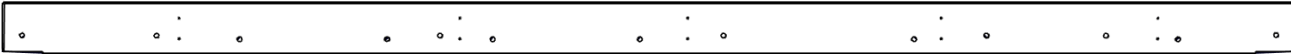

AD04 PEAK SUPPORT - W4L21848
(x1) 15/16"x4"x98 13/16" (24x102x2510)

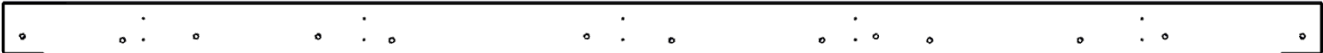

AD05 PEAK SUPPORT - W4L22017
(x1) 15/16"x4"x98 13/16" (24x102x2510)

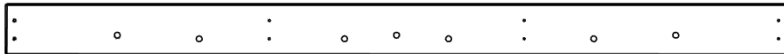

AD07 RIDGE SUPPORT - W4L21853
(x2) 15/16"x4"x60 11/16" (24x102x1541)

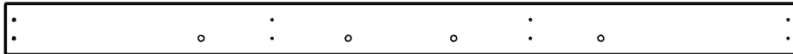

AD08 RIDGE SUPPORT - W4L21850
(x2) 15/16"x4"x60 11/16" (24x102x1541)

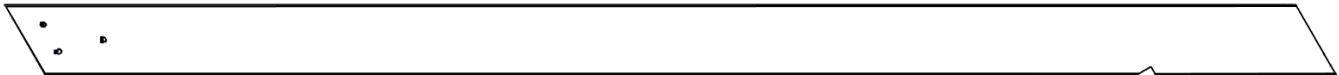

D01 FASCIA - W4L21164
(x2) 1 7/16"x5 1/4"x100" (36x134x2540)

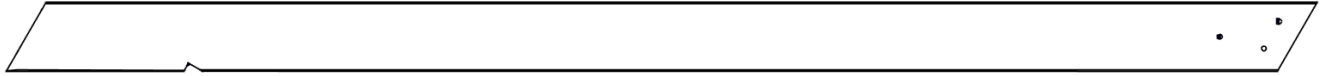

D02 FASCIA - W4L21175
(x2) 1 7/16"x5 1/4"x100" (36x134x2540)



E02 RAFTER - W4L21178
(x8) 1 7/16"x3 3/8"x95 1/16" (36x86x2414)



E04 RAFTER - W4L21176
(x8) 1 7/16"x3 3/8"x95 1/16" (36x86x2414)



E05 TRIM BOARD - W4L21849
(x3) 1 7/16"x3 3/8"x73" (36x86x1854)



E06 TRIM BOARD - W4L22012
(x2) 1 9/16"x3 3/8"x71 5/8" (36x86x1820)



E07 RAFTER - W4L21561
(x12) 1 7/16"x3 3/8"x95 1/16" (36x86x2414)



H01 PURLIN - W4L21856
(x20) 15/16"x3 3/8"x72 15/16" (24x86x1852)

OWNER'S MANUAL - PARTS IDENTIFICATIONS

WOOD COMPONENTS (NOT TO SCALE)



H07 PURLIN - W4L22007
(x10) 15/16"x3 3/8"x71 9/16" (24x86x1818)



J02 RIDGE CAP STIFFENER - W4L21177
(x2) 15/16"X2 3/8"X62 7/8" (24x60x1597)



J03 RIDGE CAP STIFFENER - W4L21180
(x2) 15/16"X2 3/8"X82 5/8" (24x60x2100)



J04 RIDGE CAP STIFFENER - W4L22018
(x2) 15/16"X2 3/8"X71 3/4" (24x60x1821)



P01 POST - W2A04544
(x2) 6"X6"X89 3/8" (152x152x2270)



P02 POST - W2A04545
(x2) 6"X6"X89 3/8" (152x152x2270)



P05 POST - W2A04800
(x2) 6"X6"X89 3/8" (152x152x2270)

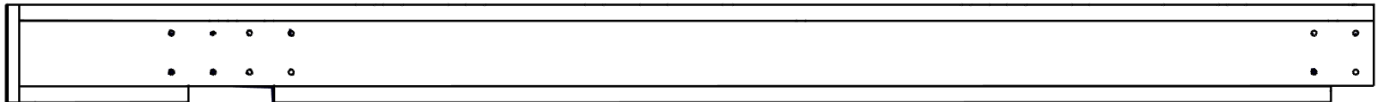

P03 BEAM - W2A04781
(x2) 6"x6 15/16"x114" (152x177x2896)

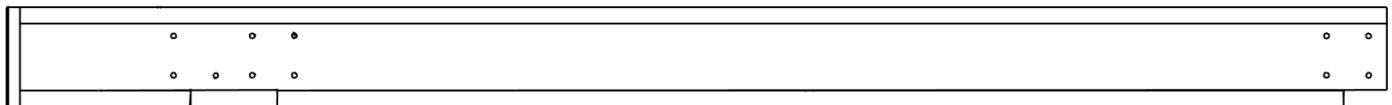

P04 BEAM - W2A04782
(x2) 6"x6 15/16"x114" (152x177x2896)



E09 TRIM BOARD W/ PRODUCT ID TAG - W2A04783
(x1) 1 1/2"x3 3/8"x73" (39x86x1854)

OWNER'S MANUAL - PARTS IDENTIFICATION

Hardware Components

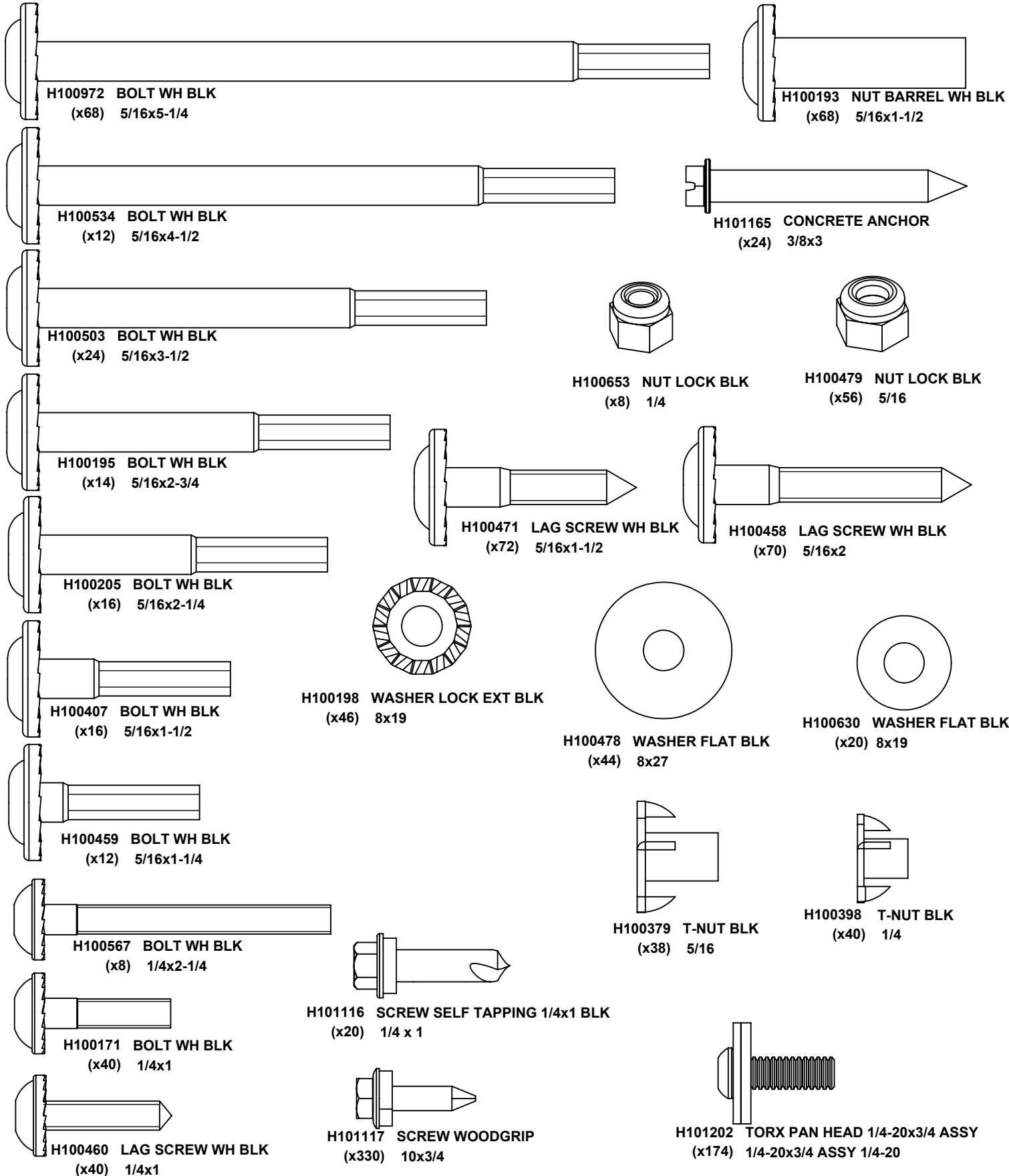

OWNER'S MANUAL - PARTS IDENTIFICATION

Hardware Components



H100201 SCREW PFH BLK
(x56) 8x2-1/2

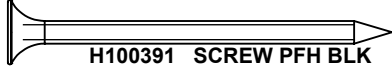

H100391 SCREW PFH BLK
(x344) 8x2

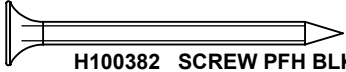

H100382 SCREW PFH BLK
(x20) 8x1-3/4

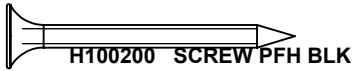

H100200 SCREW PFH BLK
(x24) 8x1-1/2



H100823 SCREW PWH BLK
(x24) 8x1-1/2

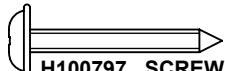

H100797 SCREW PWH BLK
(x16) 8x1

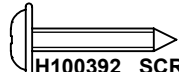

H100392 SCREW PWH BLK
(x24) 8x3/4

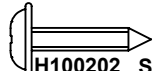

H100202 SCREW PWH BLK
(x4) 8x5/8

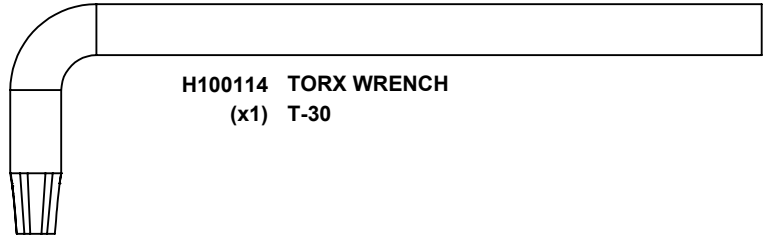

H100114 TORX WRENCH
(x1) T-30

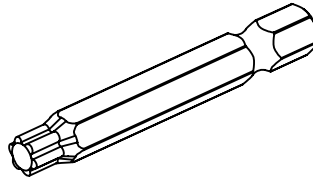

H100147 TORX BIT
(x1) T-30 T-30

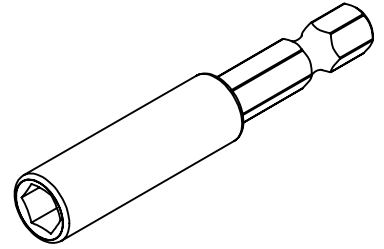

H101100 MAGNETIC DRIVER
(x1)

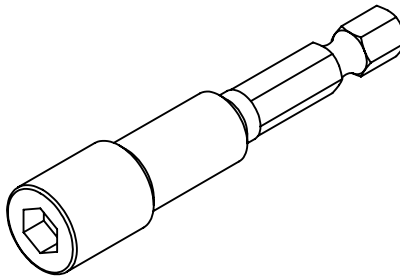

H101106 HEX DRIVER
(x1) 5/16

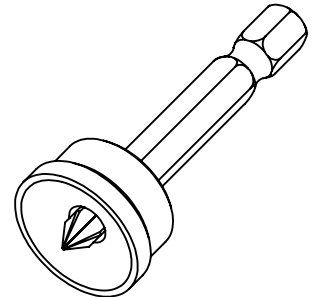

H100764 SCREW SETTER
(x1)

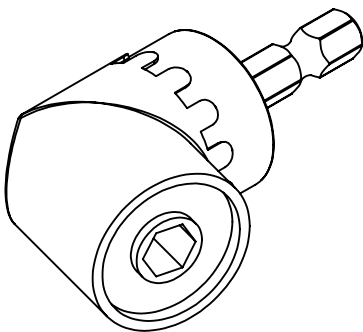

H101114 RIGHT ANGLE DRILL ADAPTER
(x1)

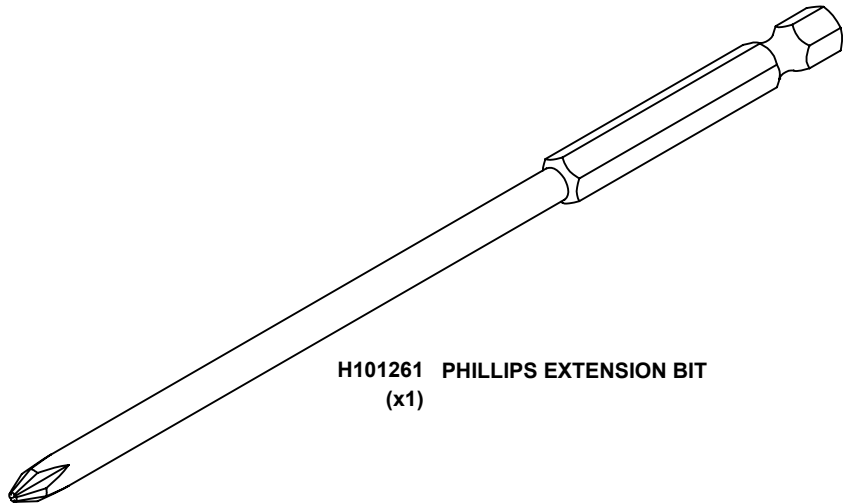

H101261 PHILLIPS EXTENSION BIT
(x1)

OWNER'S MANUAL - PARTS IDENTIFICATIONS

ACCESSORY COMPONENTS (NOT TO SCALE)

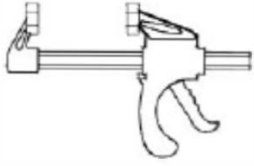

A6P00460 6" QUICK RELEASE BAR CLAMP (x2)

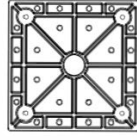

A6P00308 6x6 POST FOOT (x6)

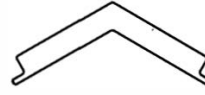

A6P00693 RIDGE CAP PROTECTOR (x2)

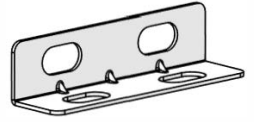

A4M04324 GABLE BEAM BRACE (x12)



A4M00978 POST PLATE (x12)

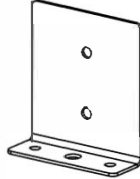

A4M00977 POST ANCHORING PLATE (x12)

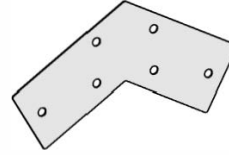

A4M02086 GABLE BRACKET (x2)

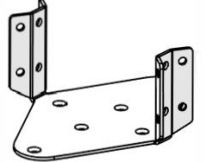

A4M02501 FAN MOUNT BRACKET (x2)

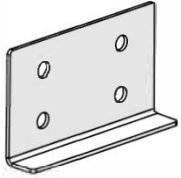

A4M01560 OUTSIDE TIE BRACKET (x4)

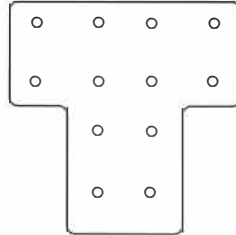

A4M04104 POST SUPPORT BRACKET (x8)

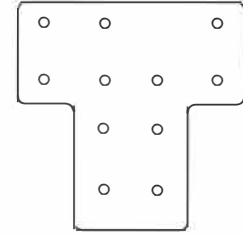

A4M04906 POST SUPPORT BRACKET (x4)



9205413 ELECTRICAL ENCLOSURE (x1)

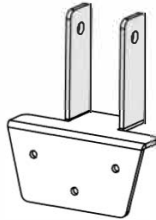

A4M05398 RAFTER CLIP (x8)

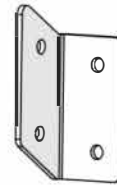

A4M04907 FASCIA BRACKET (x2)

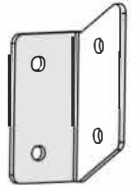

A4M04908 FASCIA BRACKET (x2)

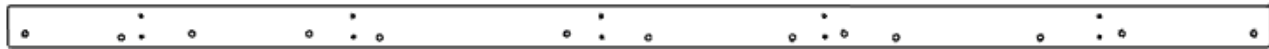

A4M05605 RIDGE PLATE (x2)

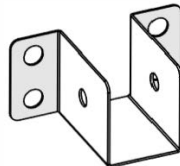

A4M04905 RIDGE CLIP (x4)

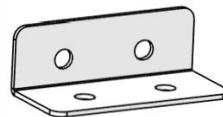

A4M04154 PURLIN SUPPORT BRACKET (x20)



A4M07048 ID TAG RANGE (x1)

OWNER'S MANUAL - PARTS IDENTIFICATIONS

METAL COMPONENTS (NOT TO SCALE)



A4M04160 29GA STEEL SHEETING
(x8)

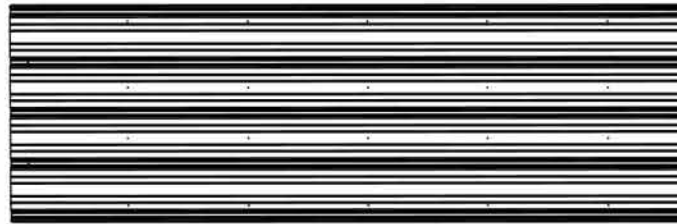

A4M04903 29GA STEEL SHEETING
(x2)

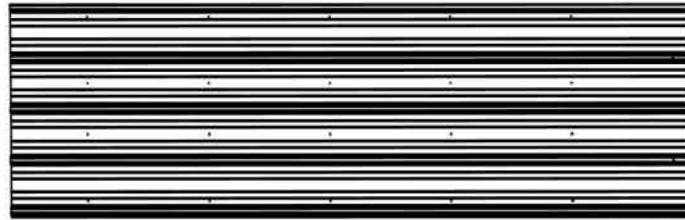

A4M05349 29GA STEEL SHEETING
(x2)



A4M05604 29GA STEEL SHEETING
(x6)



A4M05735 RIDGE CAP
(x3)

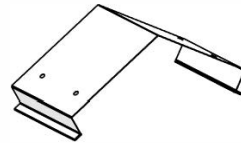

A4M04328 RIDGE CAP SPLICE
(x2)



A4M04325 ROOF END TRIM
(x2)



A4M04326 ROOF END TRIM
(x2)

OWNER'S MANUAL - PARTS IDENTIFICATIONS

METAL COMPONENTS (NOT TO SCALE)

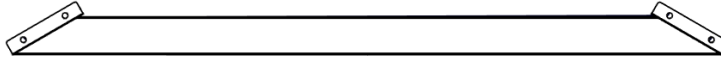
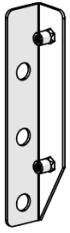

R01 RAFTER SUPPORT BRACE - A4M04329
(x4) 1 9/16"x4 3/8"x60 1/8" (40x111x1527)

C01 ANGLE BRACE BRACKET - A4M04148
(x11) 1 1/16"x1 1/4"x6" (27x31x152)

C02 ANGLE BRACE BRACKET - A4M04153
(x11) 1 1/16"x1 1/4"x6" (27x31x152)

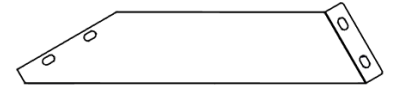

C06 ANGLE BRACE - A4M04321
(x4) 1 7/16"x5 5/16"x20 1/16" (36x135x509)

C05 ANGLE BRACE - A4M04320
(x4) 1 7/16"x5 5/16"x20 1/16" (36x135x509)

C04 ANGLE BRACE - A4M04150
(x3) 1 1/2"x5 15/16"x27 1/16" (38x151x687)

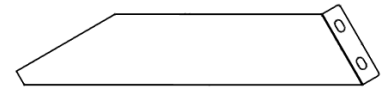
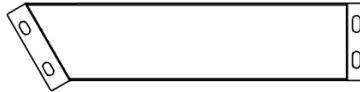

B08 GABLE SUPPORT - A4M04318
(x3) 1 1/2"x5 15/16"x24 5/8" (38x152x625)

B09 GABLE SUPPORT - A4M04319
(x3) 1 1/2"x5 15/16"x24 5/8" (38x152x625)

C03 ANGLE BRACE - A4M04149
(x3) 1 1/2"x5 15/16"x27 1/16" (38x151x687)

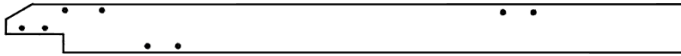

B01 GABLE BEAM - A4M04151
(x3) 1 9/16"x5 1/4"x1826 (39x134x1827)

B02 GABLE BEAM - A4M04152
(x3) 1 9/16"x5 1/4"x71 15/16" (39x134x1827)

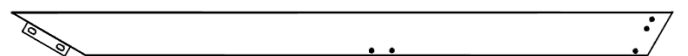
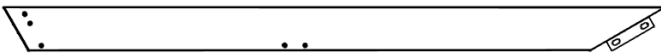

B03 GABLE BEAM - A4M04157
(x2) 1 1/2"x5 1/4"x79 1/2" (38x134x2019)

B04 GABLE BEAM - A4M04158
(x2) 1 1/2"x5 1/4"x79 1/2" (38x134x2019)

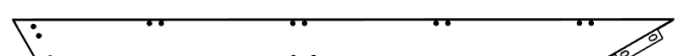
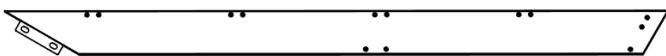

B05 GABLE BEAM - A4M05403
(x1) 1 1/2"x5 1/4"x79 1/2" (38x134x2019)

B06 GABLE BEAM - A4M05402
(x1) 1 1/2"x5 1/4"x79 1/2" (38x134x2019)

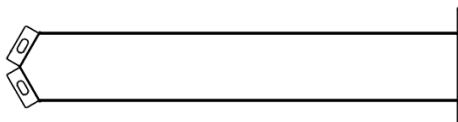

B07 VERTICAL GABLE SUPPORT - A4M04317
(x3) 1 1/2"x9 1/16"x34 11/16" (38x230x882)

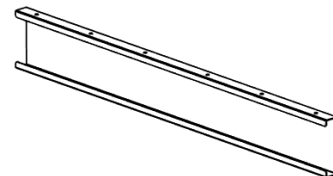

J1 SPLICE BRACKET - A4M02230
(x3) 1 5/16"x5 3/16"x39 3/8" (33.2x131.2x1000)

PRE-ASSEMBLY STEP 1 - SORTING WOOD PARTS

It is critical for ease of assembly that you take the time to sort and organize the wood and hardware.

WOOD PARTS:

- Organize wood parts by the three-digit, alpha-numeric number stamped on each board (ex. P01).
- If there are multiple boards with the same stamped number, stack those pieces together.
- Stamps can be found on the flat surface of the boards or on the end of the boards.
- Allow yourself plenty of room - the wood pieces can take up a significant amount of space.

NOTE: CARTONS ARE NOT ORGANIZED BY BOARD NUMBER.



HARDWARE PARTS:

- We recommend that you have a separate table to organize the hardware.
- Hardware bags are printed with a seven-digit, alpha-numeric part number.
- You can organize your hardware by part number or group by hardware type (i.e. bolts, nuts, etc.).
- During assembly you only need to reference the last four digits of the number.

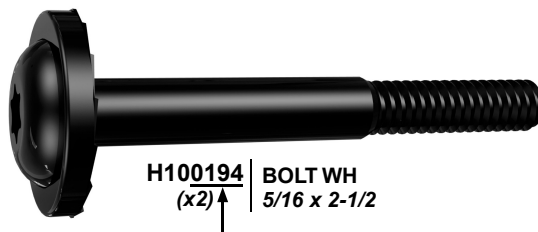

PRE-ASSEMBLY STEP 2 - TOOLS REQUIRED



Cordless Drill
or Electric Drill



Drill
Attachments:
Phillips Head



1/8", 3/16", 3/8" &
7/16" Drill Bits

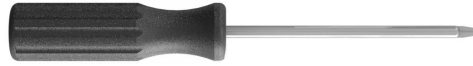

Phillips Screw Driver



Open End
Wrenches 1/2" &
9/16"



3/8" Drive Ratchet, 1/2" &
7/16" STD Sockets 1/2" & 7/16"
Deep Sockets



Claw Hammer



Rubber Mallet
- Optional

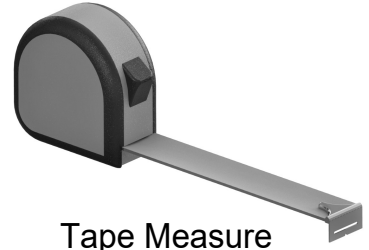

Tape Measure

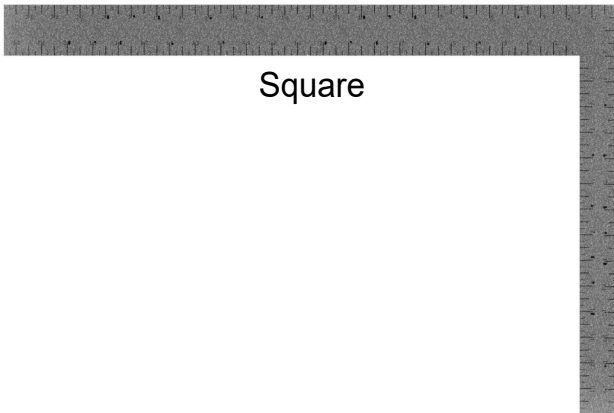

Square



Level 24"



8 FOOT LADDER REQUIRED

PRE-ASSEMBLY STEP 3 - CHOOSE YOUR ASSEMBLY METHOD

There are several types of assembly instructions available to you.

1. Printed Assembly Manual included with your set
2. BILT APP - 3D interactive instructions
3. Combination of the Printed Manual and BILT APP (Note: Step numbers can differ between the two methods)



BILT.

Scan for easy
3D instructions

Download the BILT app
before you begin

Download on the
App Store

GET IT ON
Google Play

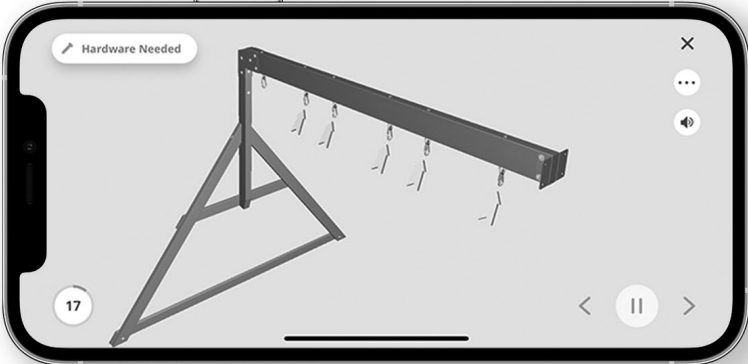

Hardware Needed

17

< || >

The image shows a smartphone displaying the BILT app interface. The screen shows a 3D assembly diagram of a metal frame structure. At the top left, there is a button labeled 'Hardware Needed'. At the bottom left, there is a circular icon with the number '17'. At the bottom right, there are navigation icons: a back arrow, a pause button, and a forward arrow. The app interface is overlaid on a dark background.

STEP 1 - POST ASSEMBLY



P01 POST - W2A04544
(x2) 6"X6"X89 3/8" (152x152x2270)



P02 POST - W2A04545
(x2) 6"X6"X89 3/8" (152x152x2270)



P05 POST - W2A04800
(x2) 6"X6"X89 3/8" (152x152x2270)

QTY	PART NUMBER	DESCRIPTION
24	H100200	SCREW PFH 8x1 1/2 BLK

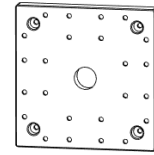

A6P00308 6x6 POST FOOT
(x6)

- FOR EASE OF ASSEMBLY, WE RECOMMEND USING SAWHORSES FOR STEPS 1-7.

CENTER POST FOOT AND DRILL 1/8" [3mm] PILOT HOLES FOR THE ATTACHMENT OF HARDWARE

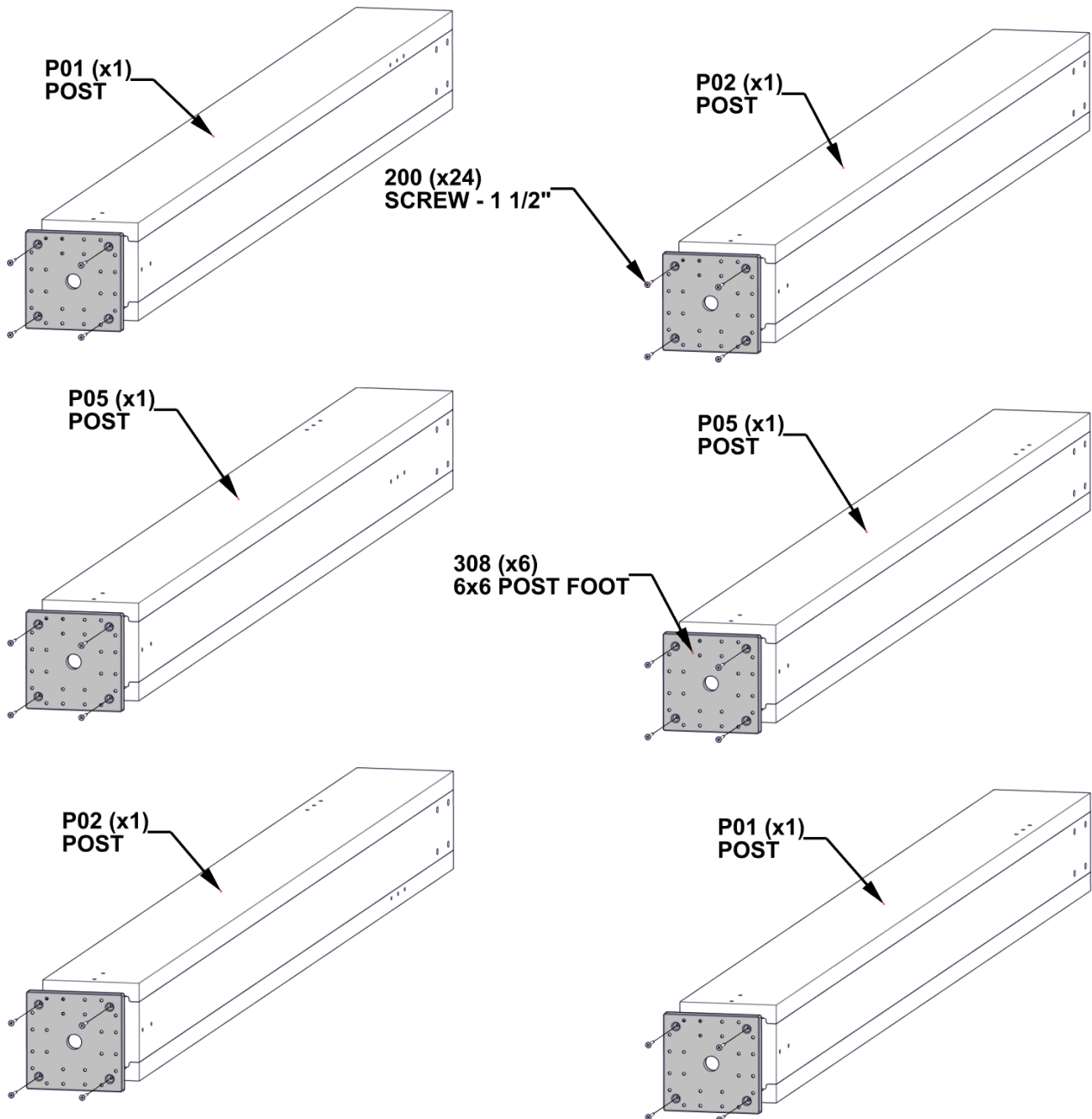

STEP 2 - BEAM ASSEMBLY

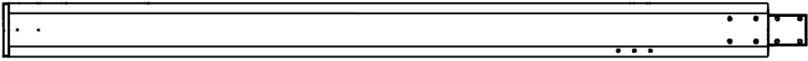

P02 POST ASSEMBLY

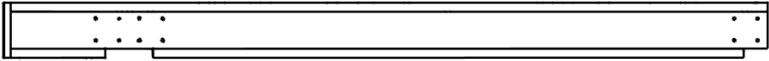

P03 BEAM - W2A04781
(x1) 6"x6 15/16"x114" (152x177x2896)

- SLIDE P02 POST INTO P03 BEAM, RUBBER Mallet MAY NEED TO BE USED TO TAP PARTS IN PLACE.
- PILOT HOLES CIRCLED IN RED INDICATE OUTSIDE BEAM ASSEMBLY.

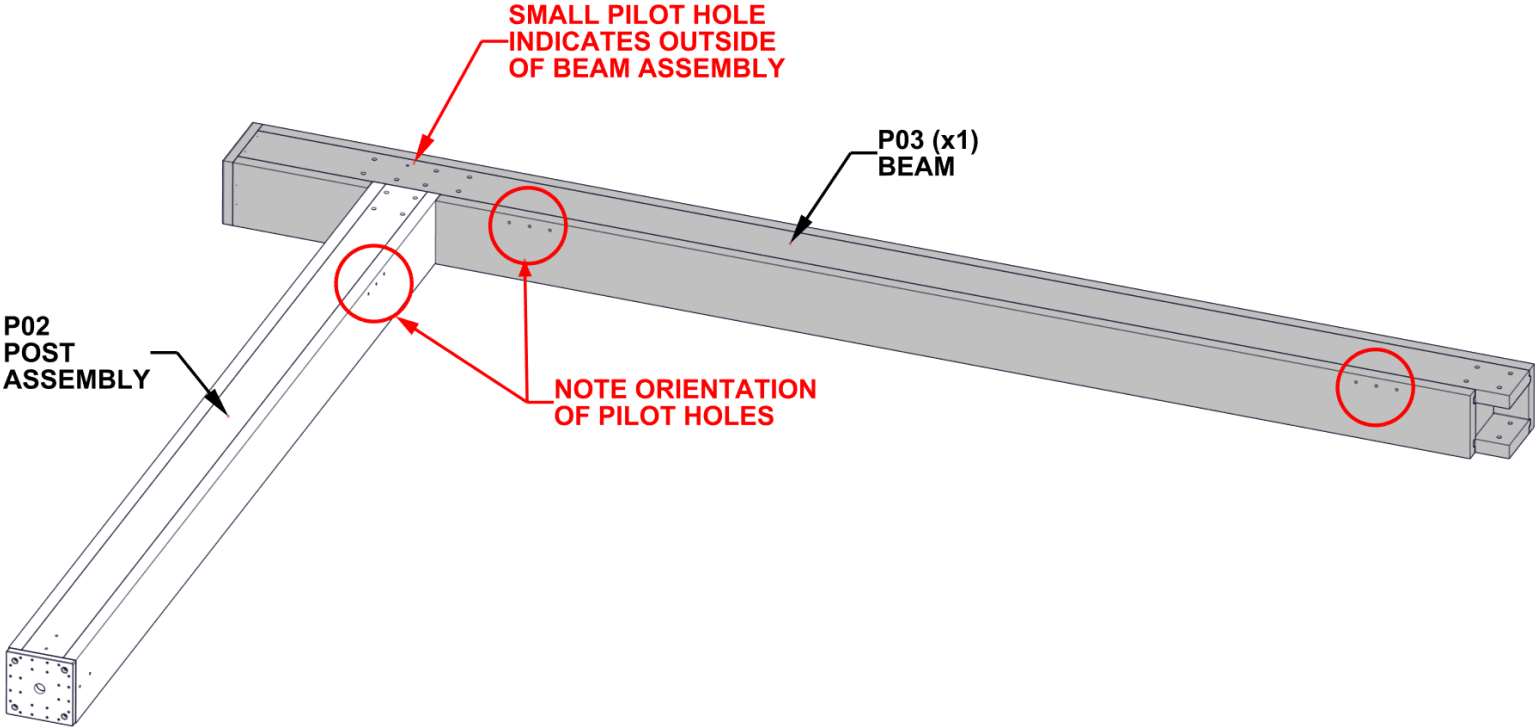

STEP 3 - BEAM ASSEMBLY

QTY	PART NUMBER	DESCRIPTION
11	H100193	NUT BARREL WH 5/16 X 1 1/2 BLK
1	H100458	LAG SCREW WH 5/16x2 BLK
11	H100972	BOLT WH 5/16x5 1/4 BLK

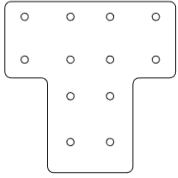

A4M04104 POST SUPPORT BRACKET
(x1)

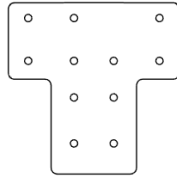

A4M04906 POST SUPPORT BRACKET
(x1)

- A4M04104 POST SUPPORT BRACKET WILL BE MOUNTED ON THE OUTSIDE OF THE ASSEMBLY.
- H100458 LAG SCREW WILL BE FASTENED IN SMALL PILOT HOLE NOTED IN PREVIOUS STEP.
- IF HOLES DO NOT ALIGN, USE A 7/16" [10mm] DRILL BIT AND METAL BRACKET AS A GUIDE TO DRILL THROUGH BOARDS.

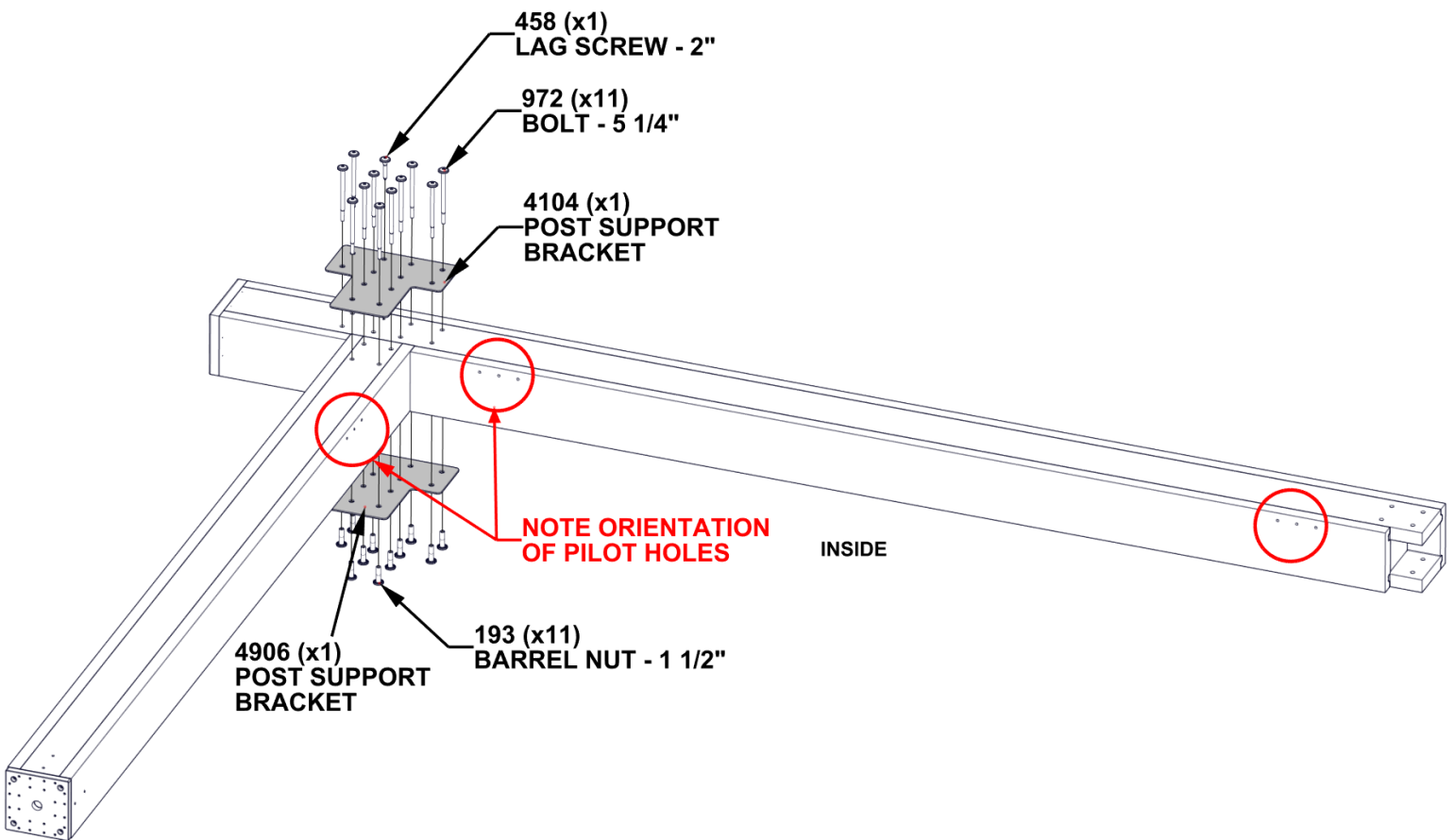

STEP 4 - BEAM ASSEMBLY

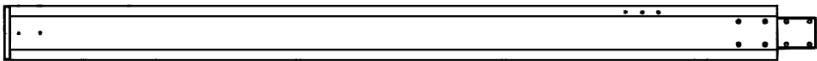

P01 POST ASSEMBLY

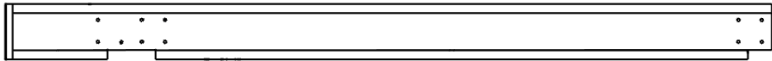

P04 BEAM - W2A04782
(x1) 6"x6 15/16"x114" (152x177x2896)

- SLIDE P01 POST INTO P04 BEAM, RUBBER Mallet MAY NEED TO BE USED TO TAP PARTS IN PLACE.

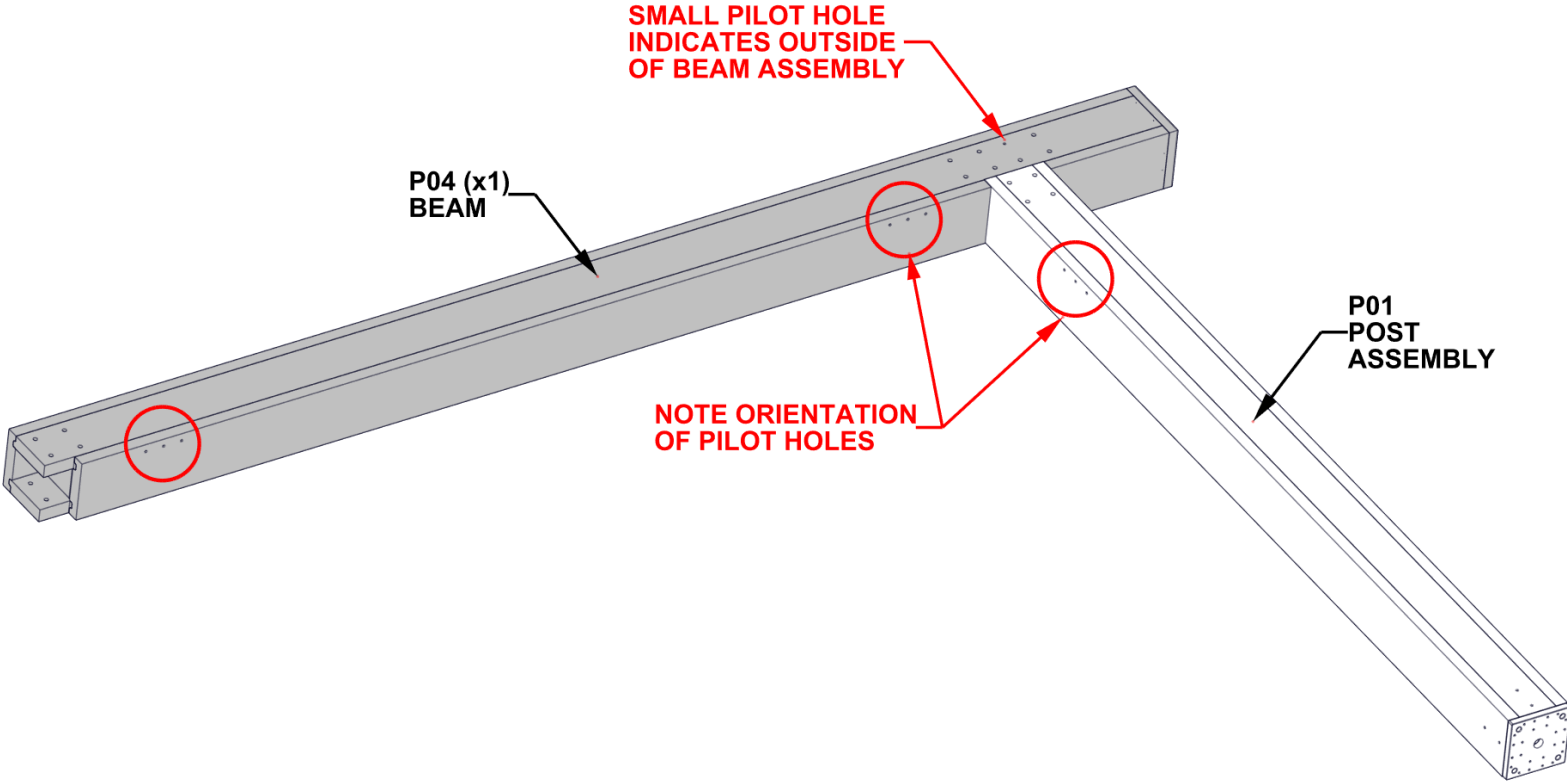

STEP 5 - BEAM ASSEMBLY

QTY	PART NUMBER	DESCRIPTION
11	H100193	NUT BARREL WH 5/16 X 1 1/2 BLK
1	H100458	LAG SCREW WH 5/16x2 BLK
11	H100972	BOLT WH 5/16x5 1/4 BLK

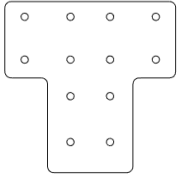

A4M04104 POST SUPPORT BRACKET (x1)

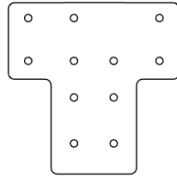

A4M04906 POST SUPPORT BRACKET (x1)

- A4M04104 POST SUPPORT BRACKET WILL BE MOUNTED ON THE OUTSIDE OF THE ASSEMBLY.
- H100458 LAG SCREW WILL BE FASTENED IN SMALL PILOT HOLE NOTED IN PREVIOUS STEP.
- IF HOLES DO NOT ALIGN, USE A 7/16" [10mm] DRILL BIT AND METAL BRACKET AS A GUIDE TO DRILL THROUGH THE BOARD

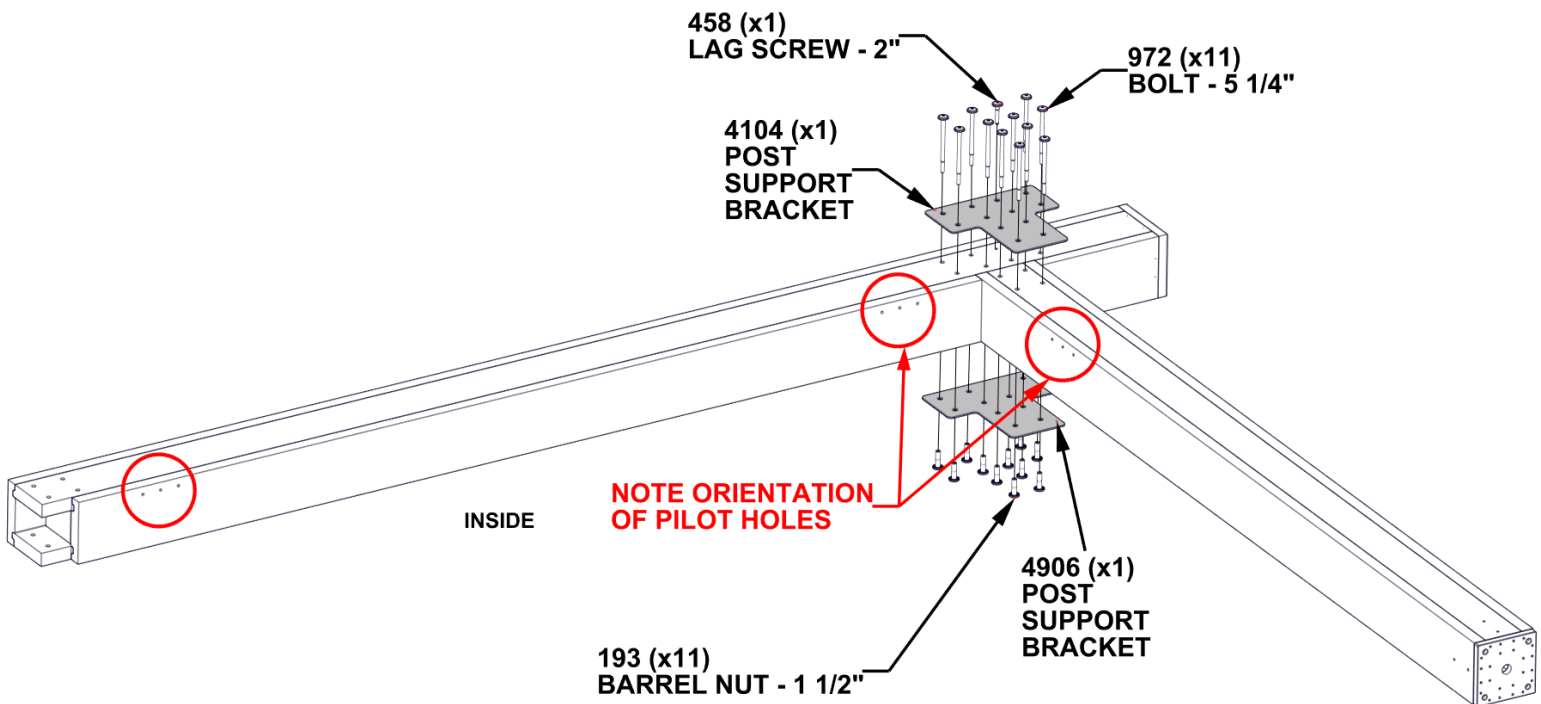

STEP 6 - BEAM ASSEMBLY

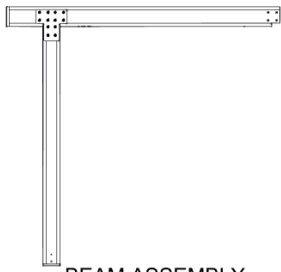

BEAM ASSEMBLY FROM STEP 3



BEAM ASSEMBLY FROM STEP 5

QTY	PART NUMBER	DESCRIPTION
4	H100193	NUT BARREL WH 5/16 X 1 1/2 BLK
4	H100972	BOLT WH 5/16x5 1/4 BLK

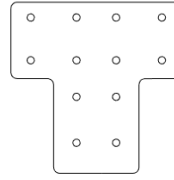

A4M04104 POST SUPPORT BRACKET (x2)

- HAND TIGHTEN ONLY.

- IF HOLES DO NOT ALIGN, USE A 7/16" [10mm] DRILL BIT AND METAL BRACKET AS A GUIDE TO DRILL THROUGH THE BOARDS.

972 (x4)
BOLT - 5 1/4"

4104 (x2)
POST SUPPORT
BRACKET

193 (x4)
BARREL NUT - 1 1/2"

BEAM ASSEMBLY FROM STEP 3

BEAM ASSEMBLY FROM STEP 5

STEP 7 - BEAM ASSEMBLY

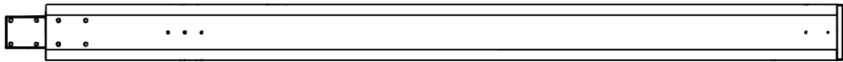

P05 POST - W2A04800
(x1) 6"X6"X89 3/8" (152x152x2270)

- SLIDE P05 POST INTO BEAM ASSEMBLY, RUBBER Mallet MAY NEED TO BE USED TO TAP PARTS IN PLACE.

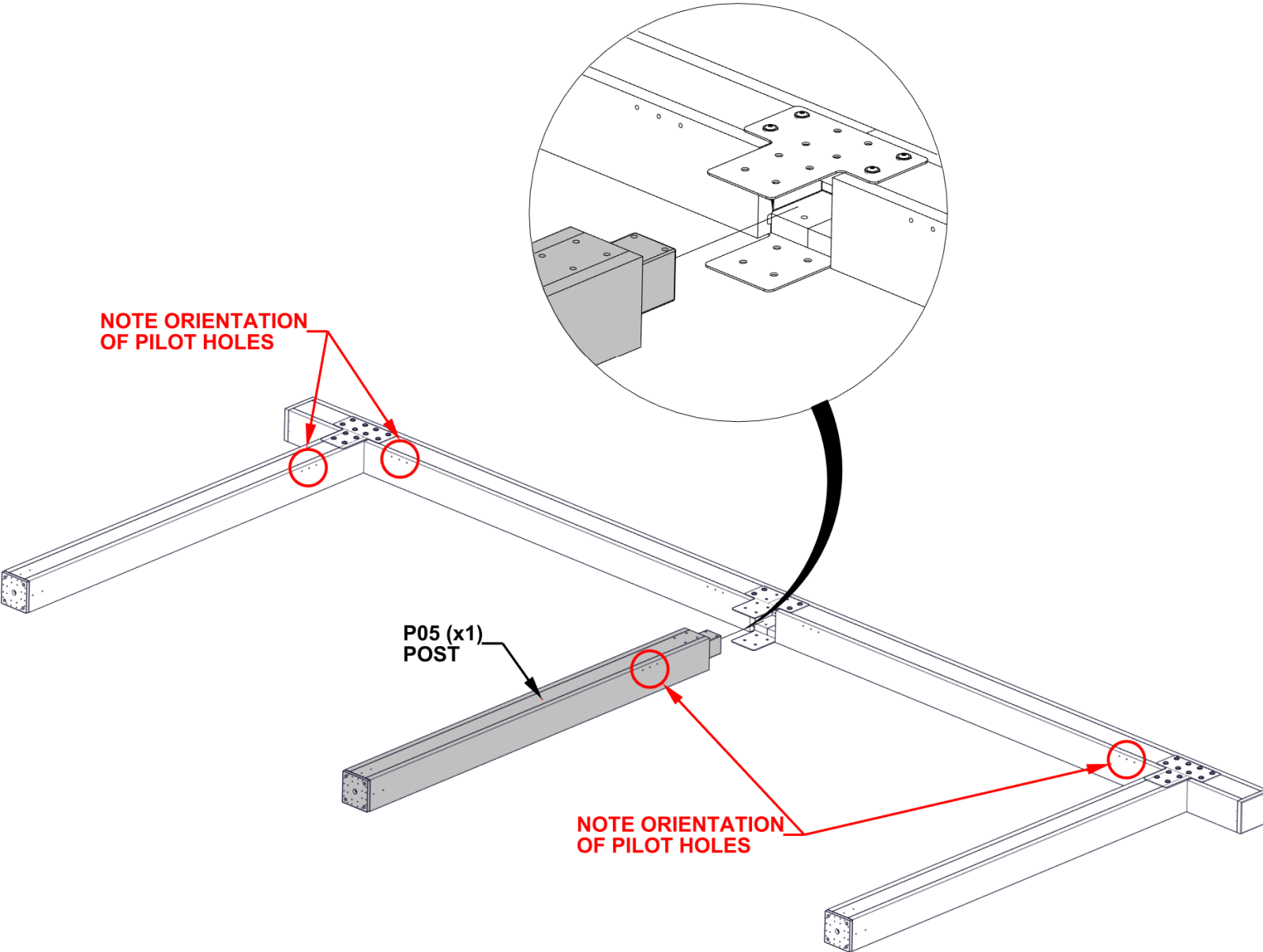

STEP 8 - BEAM ASSEMBLY

QTY	PART NUMBER	DESCRIPTION
12	H100471	LAG SCREW WH 5/16x1 1/2 BLK

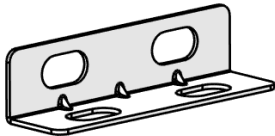

A4M04324 GABLE BEAM BRACE
(x6)

- ALIGN GABLE BEAM BRACE WITH PILOT HOLES LOCATED ON OF BEAM ASSEMBLY.

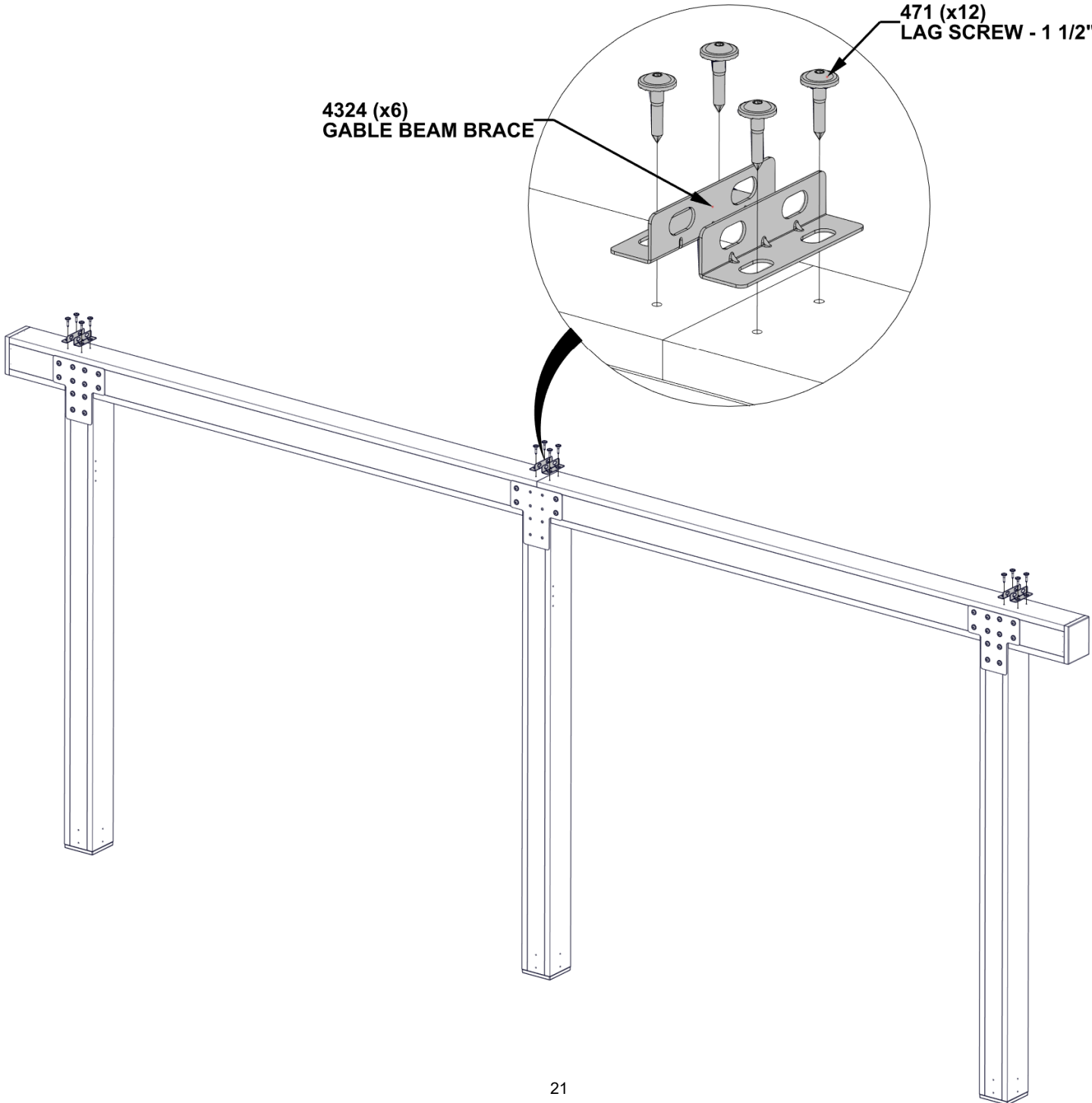

STEP 9 - BEAM ASSEMBLY

QTY	PART NUMBER	DESCRIPTION
8	H100193	NUT BARREL WH 5/16 X 1 1/2 BLK
8	H100972	BOLT WH 5/16x5 1/4 BLK

- HAND TIGHTEN ONLY. AFTER ALL HARDWARE HAS BEEN INSTALLED, FULLY TIGHTEN HARDWARE.

- STAND BEAM ASSEMBLY IN THE UPRIGHT POSITION AND ATTACH REMAINING HARDWARE AS SHOWN.

- AFTER HARDWARE HAS BEEN INSTALLED, SET BEAM ASSEMBLY BACK ON THE GROUND.

- IF HOLES DO NOT ALIGN, USE A 7/16" [10mm] DRILL BIT AND METAL BRACKET AS A GUIDE TO DRILL THROUGH THE BOARDS.

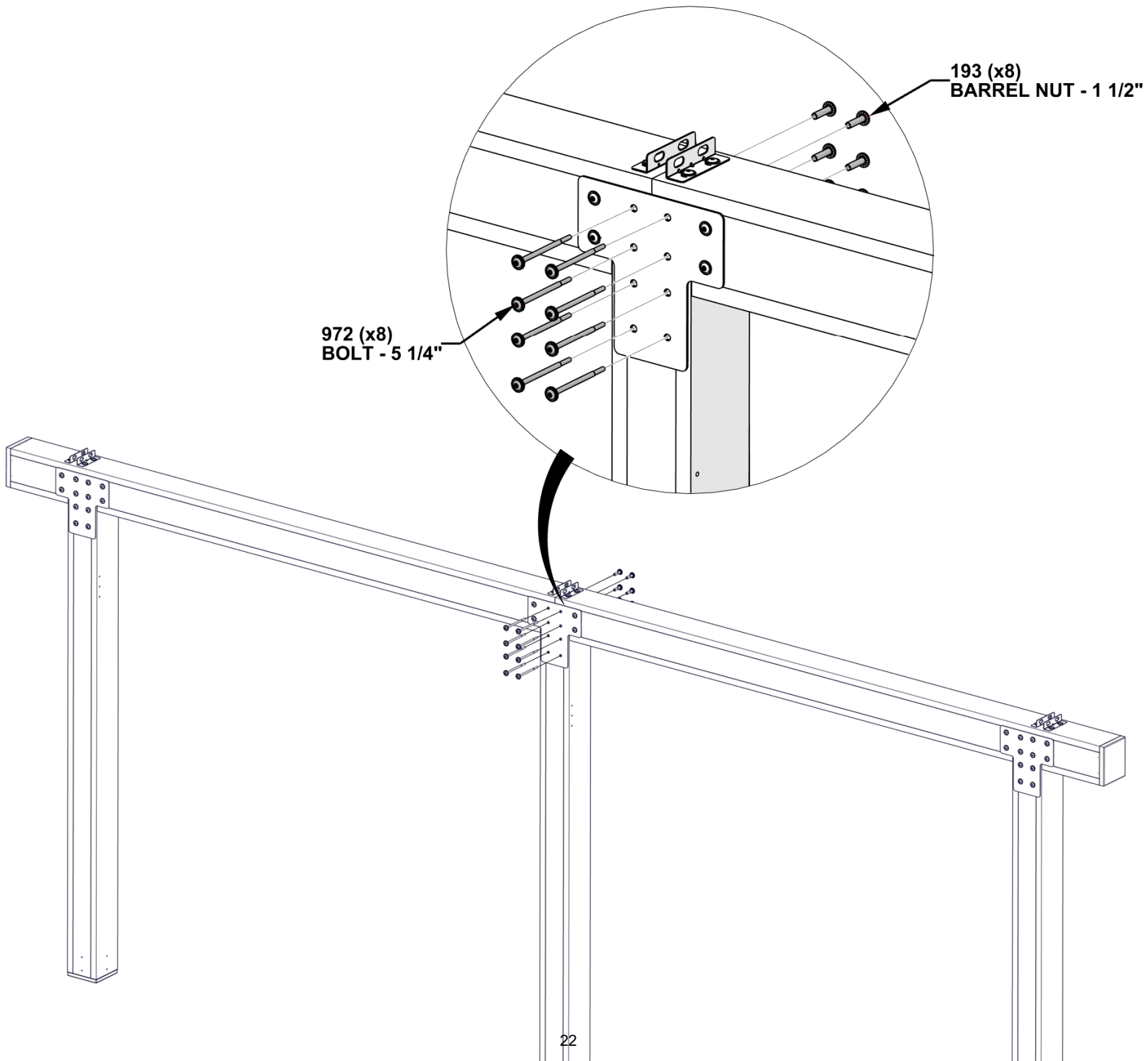

**REPEAT POST AND BEAM ASSEMBLY
STEPS 2 THROUGH 9**

STEP 10 - GABLE ASSEMBLY

QTY	PART NUMBER	DESCRIPTION
15	H101202	TORX PAN HEAD 1/4-20x3/4 ASSY

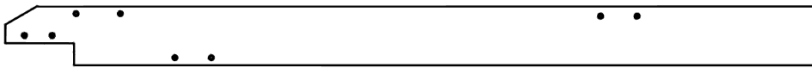

B01 GABLE BEAM - A4M04151
(x2) 1 9/16"x5 1/4"x1826 (39x134x1827)

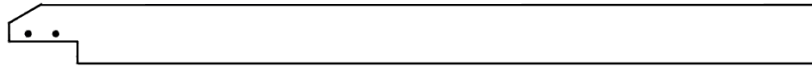

B02 GABLE BEAM - A4M04152
(x1) 1 9/16"x5 1/4"x71 15/16" (39x134x1827)

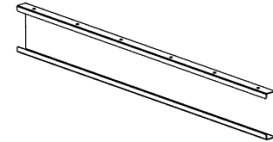

J1 SPLICE BRACKET - A4M02230
(x3) 1 5/16"x5 3/16"x39 3/8" (33x131x1000)

- HAND TIGHTEN HARDWARE.
- NOTE ORIENTATION OF J1 SPLICE BRACKET.
- SLIDE J1 SPLICE BRACKET INTO THE GABLE BEAMS AS SHOWN.
- ALIGN PILOT HOLES AND ATTACH WITH HARDWARE PROVIDED.

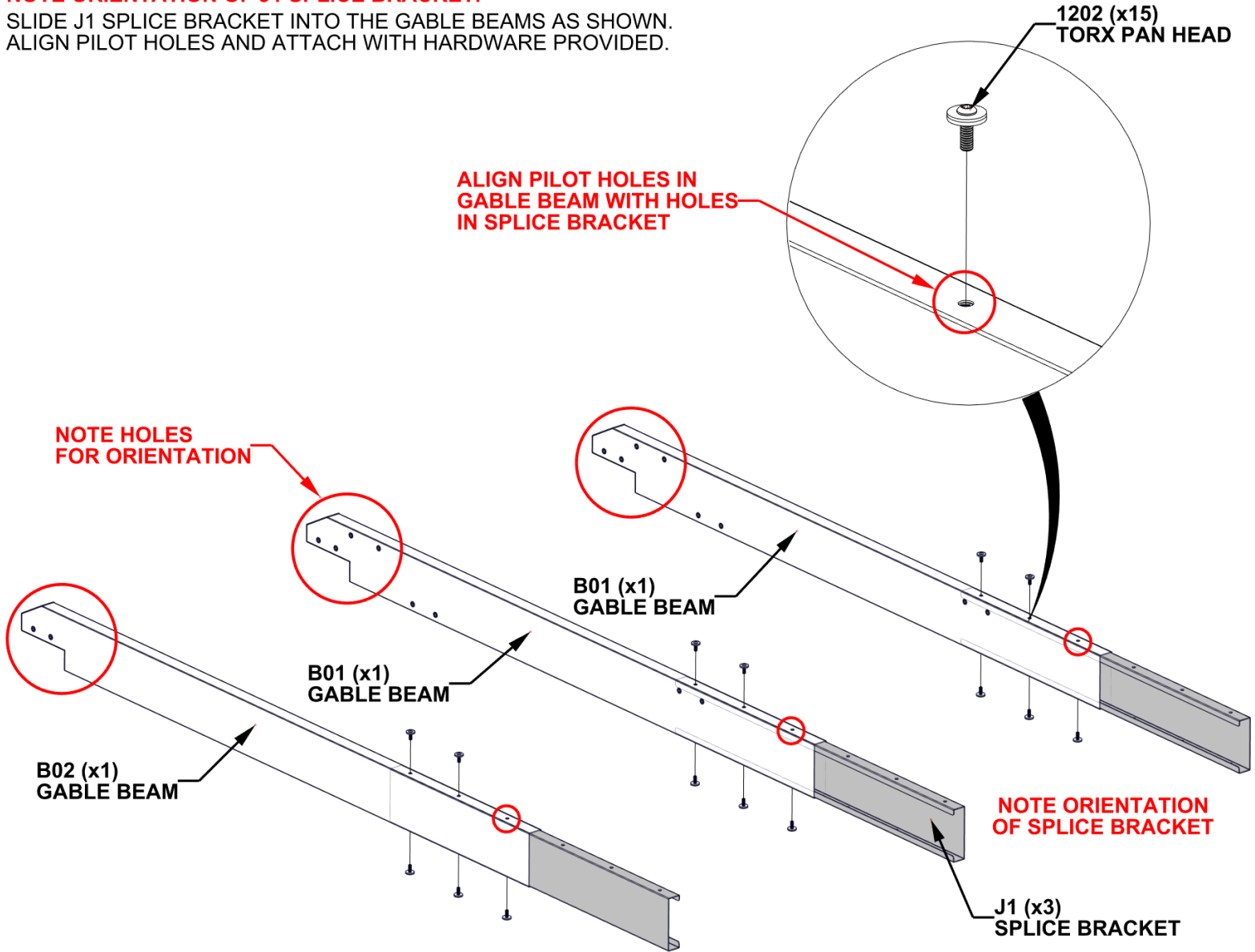

LEAVE CIRCLED SLOTS ABOVE EMPTY, HARDWARE WILL BE ADDED IN FUTURE STEPS.

STEP 11 - GABLE ASSEMBLY

QTY	PART NUMBER	DESCRIPTION
15	H101202	TORX PAN HEAD 1/4-20x3/4 ASSY

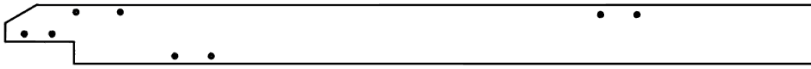

B01 GABLE BEAM - A4M04151
(x1) 1 9/16"x5 1/4"x1826 (39x134x1827)

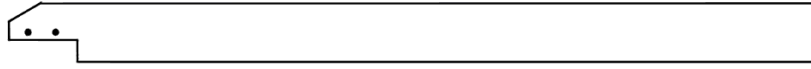

B02 GABLE BEAM - A4M04152
(x2) 1 9/16"x5 1/4"x71 15/16" (39x134x1827)

- AFTER HARDWARE HAS BEEN INSERTED, FULLY TIGHTEN HARDWARE.

- SLIDE GABLE BEAMS B01 AND B02 OVER J1 SPLICE BRACKET.
- ALIGN PILOT HOLES AND ATTACH WITH HARDWARE PROVIDED.

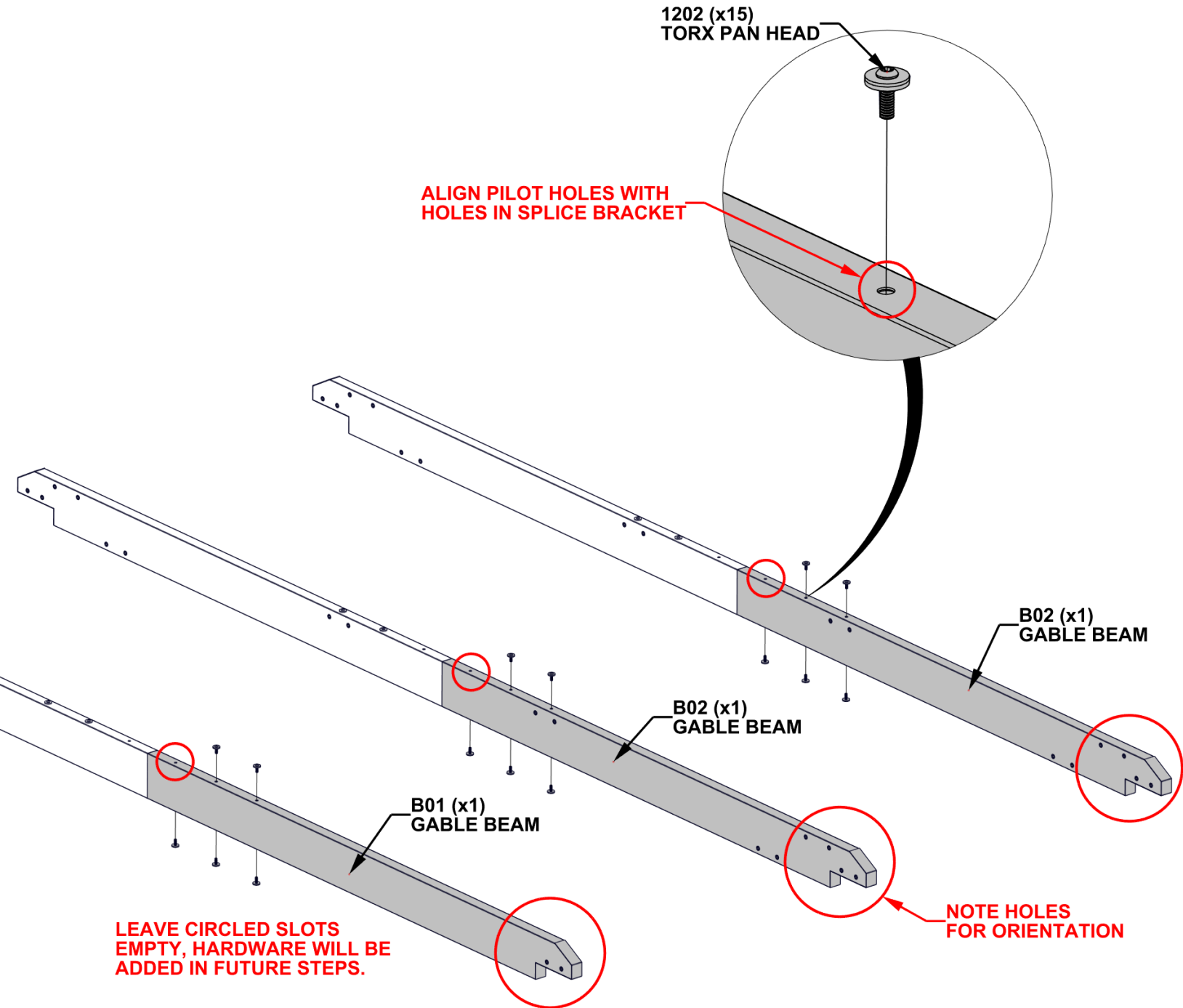

STEP 12 - FRAME ASSEMBLY

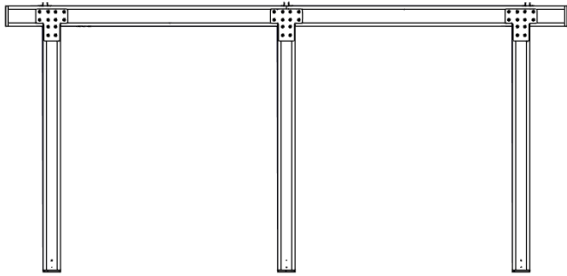

BEAM ASSEMBLY
(x2)

QTY	PART NUMBER	DESCRIPTION
24	H101202	TORX PAN HEAD 1/4-20x3/4 ASSY

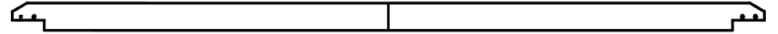

GABLE BEAM ASSEMBLY
(x3)

- HAND TIGHTEN HARDWARE.

- ADDITIONAL PEOPLE MAY BE HELPFUL FOR THIS STEP.

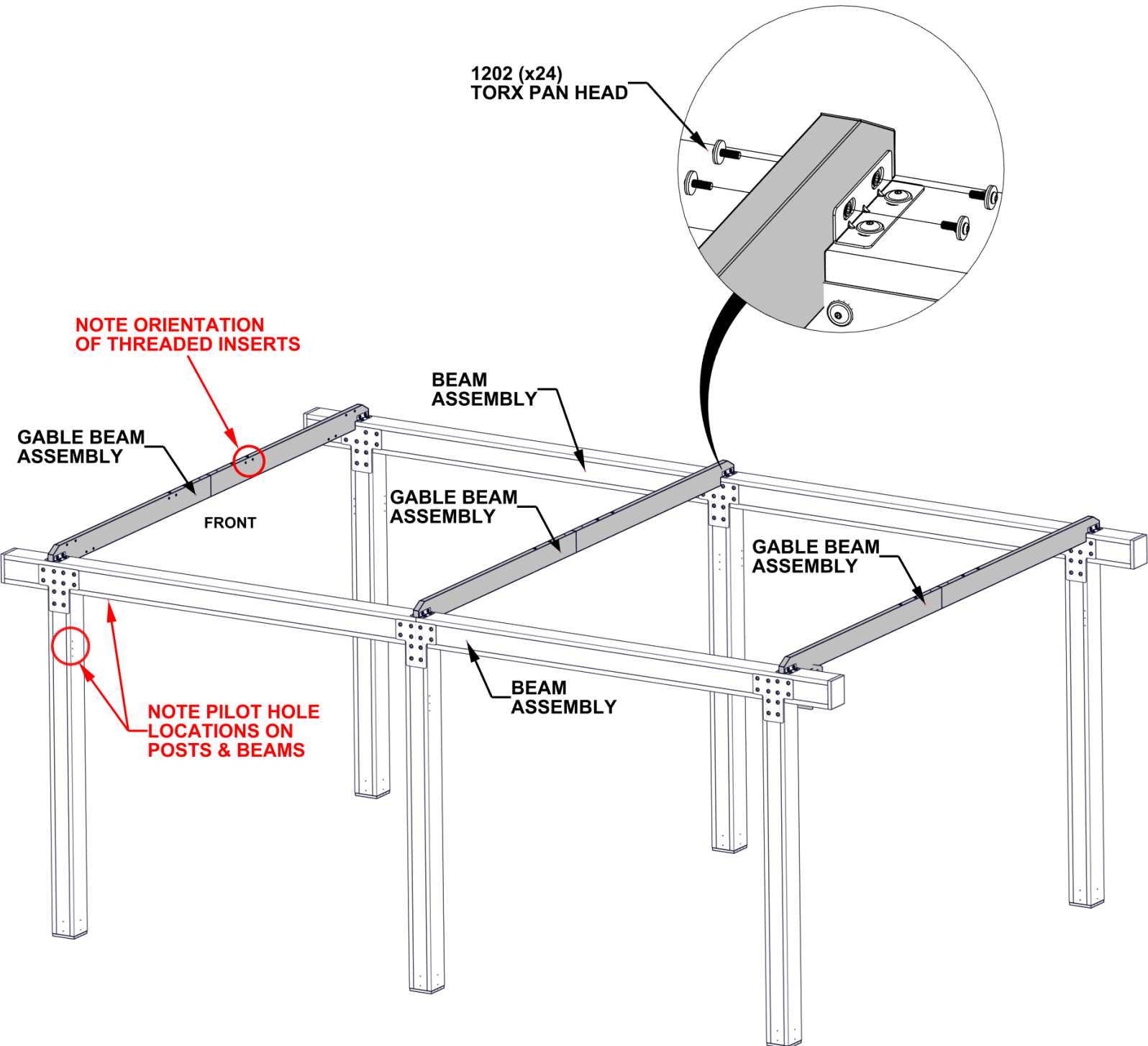

STEP 13 - SQUARE ASSEMBLY

CRITICAL:

- SQUARE UNIT BEFORE PROCEEDING TO NEXT STEPS.
- THE BELOW DIMENSIONS ARE CRITICAL TO THE FINAL ASSEMBLY.
- MEASUREMENTS SHOULD BE WITHIN $\pm 1/4"$ [6mm].
- MEASUREMENTS OUTSIDE OF TOLERANCE WILL LEAD TO ISSUES ON FUTURE ASSEMBLY STEPS.
- AFTER UNIT HAS BEEN SQUARED, COMPLETELY TIGHTEN HARDWARE.

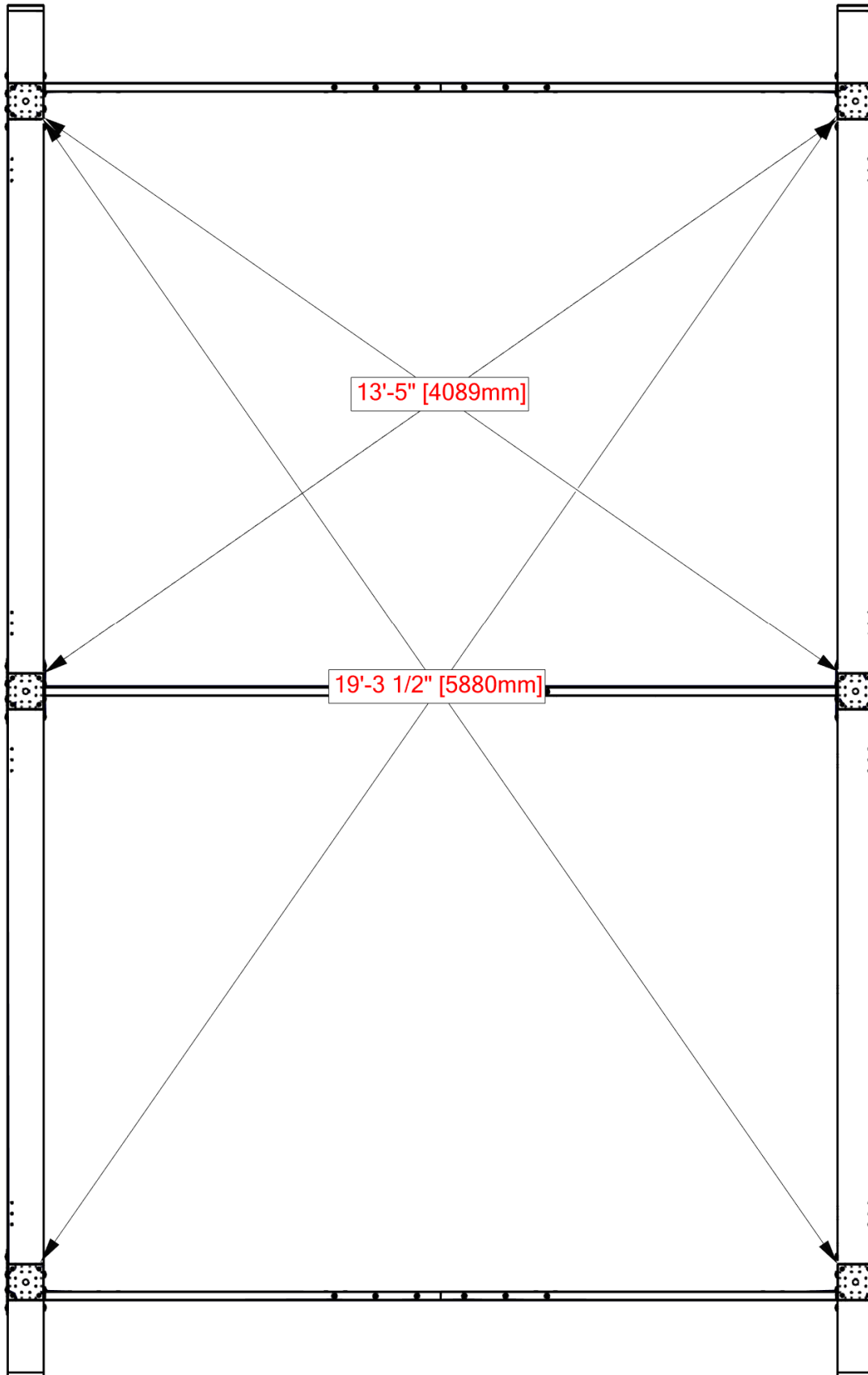

STEP 14 - ANGLE BRACE ASSEMBLY

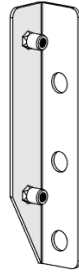
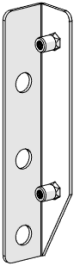

QTY	PART NUMBER	DESCRIPTION
18	H100458	LAG SCREW WH 5/16x2 BLK

C01 ANGLE BRACE BRACKET - A4M04148
(x3) 1 1/16"x1 1/4"x6" (27x31x152)

C02 ANGLE BRACE BRACKET - A4M04153
(x3) 1 1/16"x1 1/4"x6" (27x31x152)

- ALIGN BRACKET WITH PILOT HOLES IN POST AND FOLLOW MEASUREMENTS AS SHOWN.

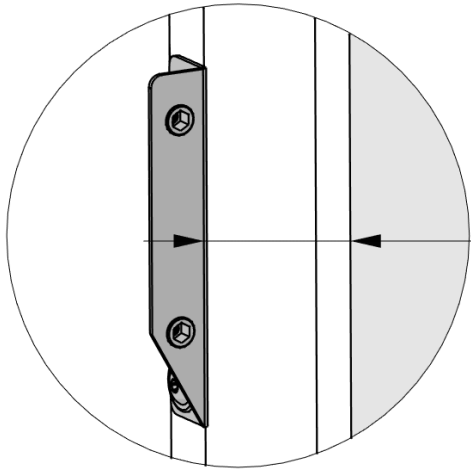

4-5/8" [117mm]

NOTE ORIENTATION OF BRACKET ON POST. THE ANGLED PORTION FACES DOWN.

458 (x18)
LAG SCREW - 2"

C02 (x1)
ANGLE
BRACE
BRACKET

HAND TIGHTEN HARDWARE, MEASURE FROM THE INSIDE OF THE POST TO BRACKET AS SHOWN. DO THIS FOR THE 4 OUTSIDE CORNER POSTS. THIS MEASUREMENT SHOULD BE 4-5/8" [117mm].

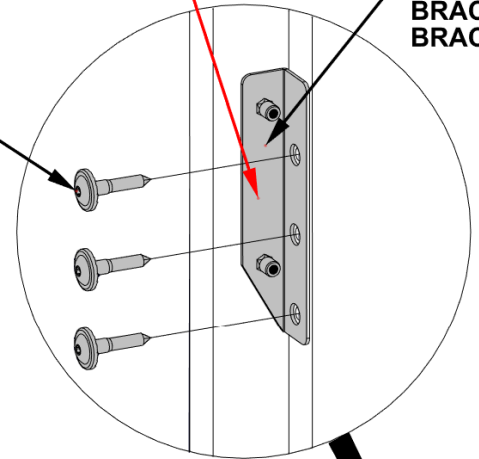

FRONT

C01 (x1)
ANGLE
BRACE
BRACKET

C02 (x1)
ANGLE
BRACE
BRACKET

C02 (x1)
ANGLE
BRACE
BRACKET

C01 (x1)
ANGLE
BRACE
BRACKET

C01 (x1)
ANGLE
BRACE
BRACKET

STEP 15 - ANGLE BRACE ASSEMBLY

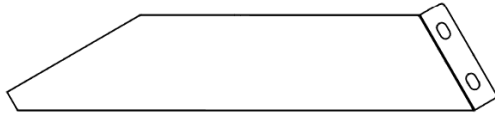

C03 ANGLE BRACE - A4M04149
(x3) 1 1/2"x5 15/16"x27 1/16" (38x151x687)

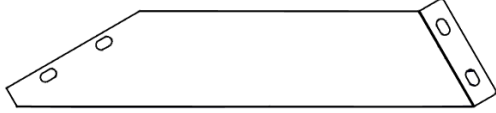

C04 ANGLE BRACE - A4M04150
(x3) 1 1/2"x5 15/16"x27 1/16" (38x151x687)

QTY	PART NUMBER	DESCRIPTION
24	H101202	TORX PAN HEAD 1/4-20x3/4 ASSY

- HAND TIGHTEN UNTIL ALL HARDWARE IS INSERTED, THEN FULLY TIGHTEN.

- ALIGN ANGLE BRACE WITH THREADED INSERTS AS SHOWN.

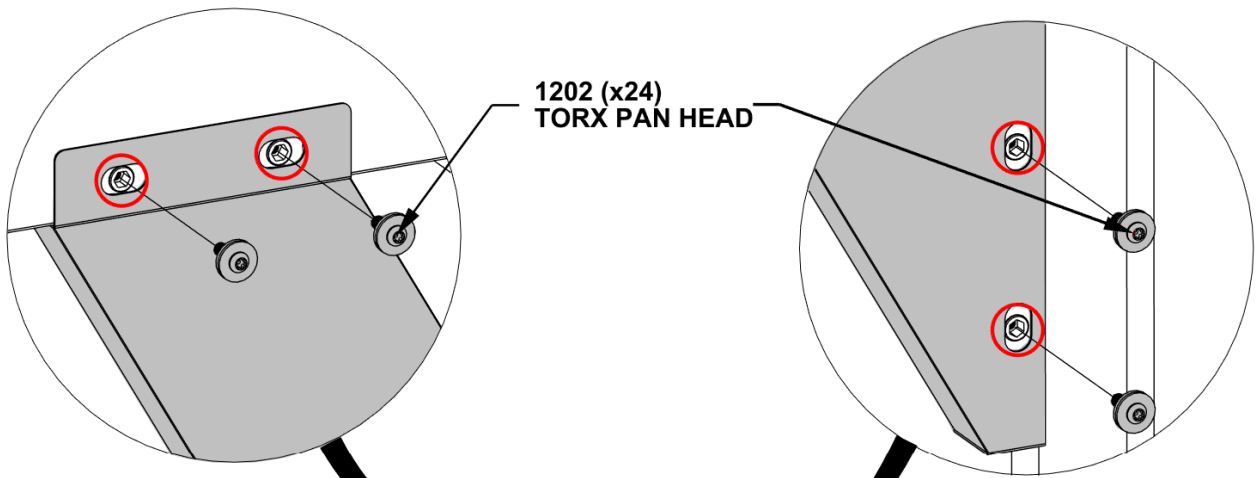

1202 (x24)
TORX PAN HEAD

C03 (x1)
ANGLE
BRACE

C04 (x1)
ANGLE
BRACE

C04 (x1)
ANGLE
BRACE

C03 (x1)
ANGLE
BRACE

C04 (x1)
ANGLE
BRACE

C03 (x1)
ANGLE
BRACE

FRONT

STEP 16 - ANGLE BRACE ASSEMBLY

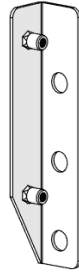
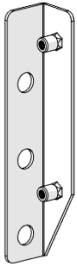

QTY	PART NUMBER	DESCRIPTION
24	H100458	LAG SCREW WH 5/16x2 BLK

C01 ANGLE BRACE BRACKET - A4M04148
(x4) 1 1/16"x1 1/4"x6" (27x31x152)

C02 ANGLE BRACE BRACKET - A4M04153
(x4) 1 1/16"x1 1/4"x6" (27x31x152)

- MEASURE 4-5/8" [117mm] FROM THE INSIDE OF THE POST TO THE BRACKET.

- ALIGN BRACKET WITH PILOT HOLES IN POST AS SHOWN.

C01 (x1)
ANGLE
BRACE
BRACKET

458 (x24)
LAG SCREW - 2"

C02 (x1)
ANGLE
BRACE
BRACKET

**NOTE ORIENTATION OF BRACKET
ON POST. THE ANGLED PORTION
FACES AWAY FROM CORNER OF
BEAM/POST ASSEMBLY.**

C01 (x1)
ANGLE
BRACE
BRACKET

C02 (x1)
ANGLE
BRACE
BRACKET

C01 (x1)
ANGLE
BRACE
BRACKET

C02 (x1)
ANGLE
BRACE
BRACKET

FRONT

C01 (x1)
ANGLE
BRACE
BRACKET

C02 (x1)
ANGLE
BRACE
BRACKET

STEP 17 - ANGLE BRACE ASSEMBLY

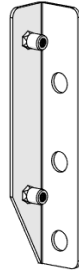
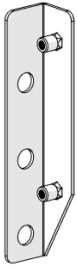

QTY	PART NUMBER	DESCRIPTION
24	H100458	LAG SCREW WH 5/16x2 BLK

C01 ANGLE BRACE BRACKET - A4M04148
(x4) 1 1/16"x1 1/4"x6" (27x31x152)

C02 ANGLE BRACE BRACKET - A4M04153
(x4) 1 1/16"x1 1/4"x6" (27x31x152)

- MEASURE 4-5/8" [117mm] FROM THE INSIDE OF THE POST TO THE BRACKET.

- ALIGN BRACKET WITH PILOT HOLES IN POST AS SHOWN.

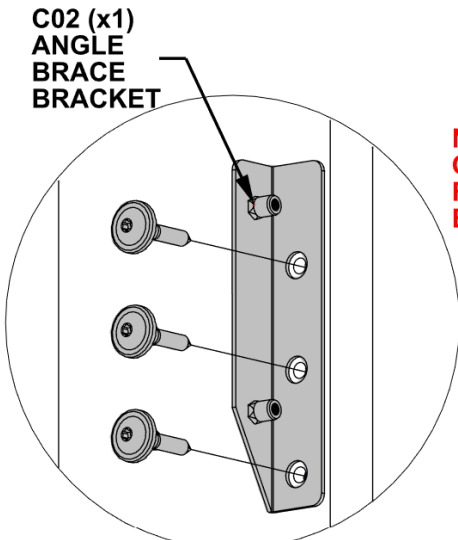

NOTE ORIENTATION OF BRACKET ON POST. THE ANGLED PORTION FACES AWAY FROM CORNER OF BEAM/POST ASSEMBLY.

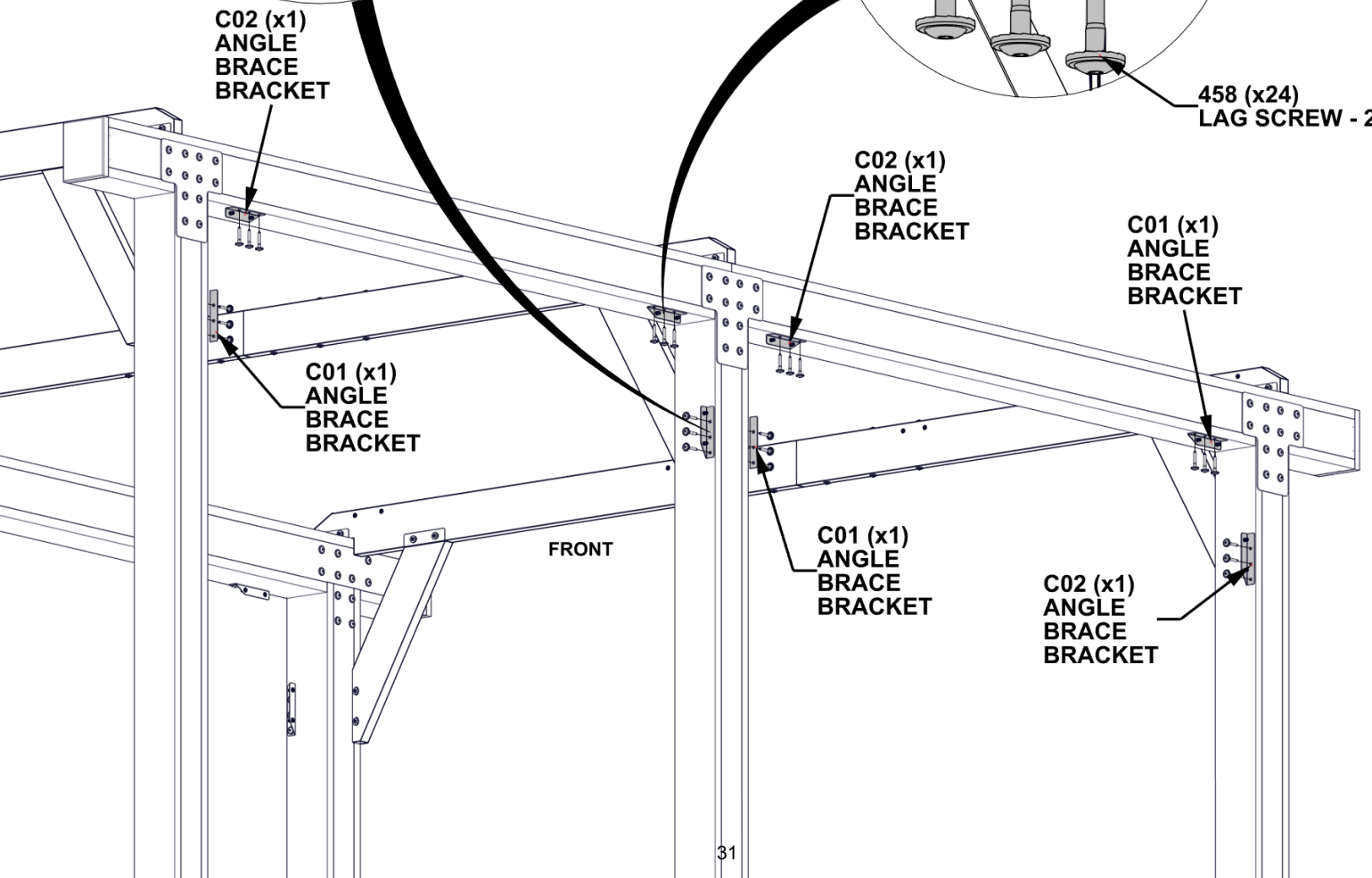
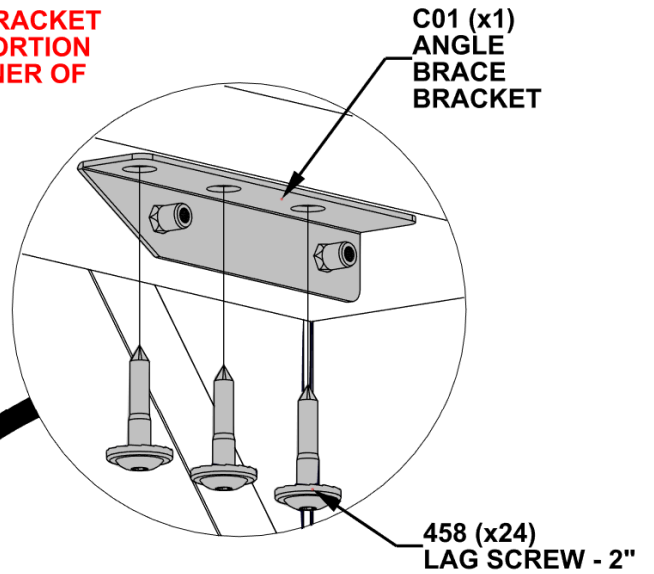

STEP 18 - ANGLE BRACE ASSEMBLY

QTY	PART NUMBER	DESCRIPTION
16	H101202	TORX PAN HEAD 1/4-20x3/4 ASSY

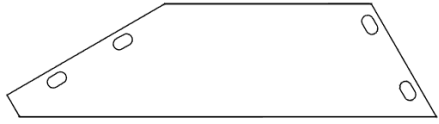

C06 ANGLE BRACE - A4M04321
(x2) 1 7/16"x5 5/16"x20 1/16" (36x135x509)



C05 ANGLE BRACE - A4M04320
(x2) 1 7/16"x5 5/16"x20 1/16" (36x135x509)

- HAND TIGHTEN UNTIL ALL HARDWARE IS INSERTED, THEN FULLY TIGHTEN.

- ALIGN BRACKET WITH PILOT HOLES IN POST AS SHOWN.

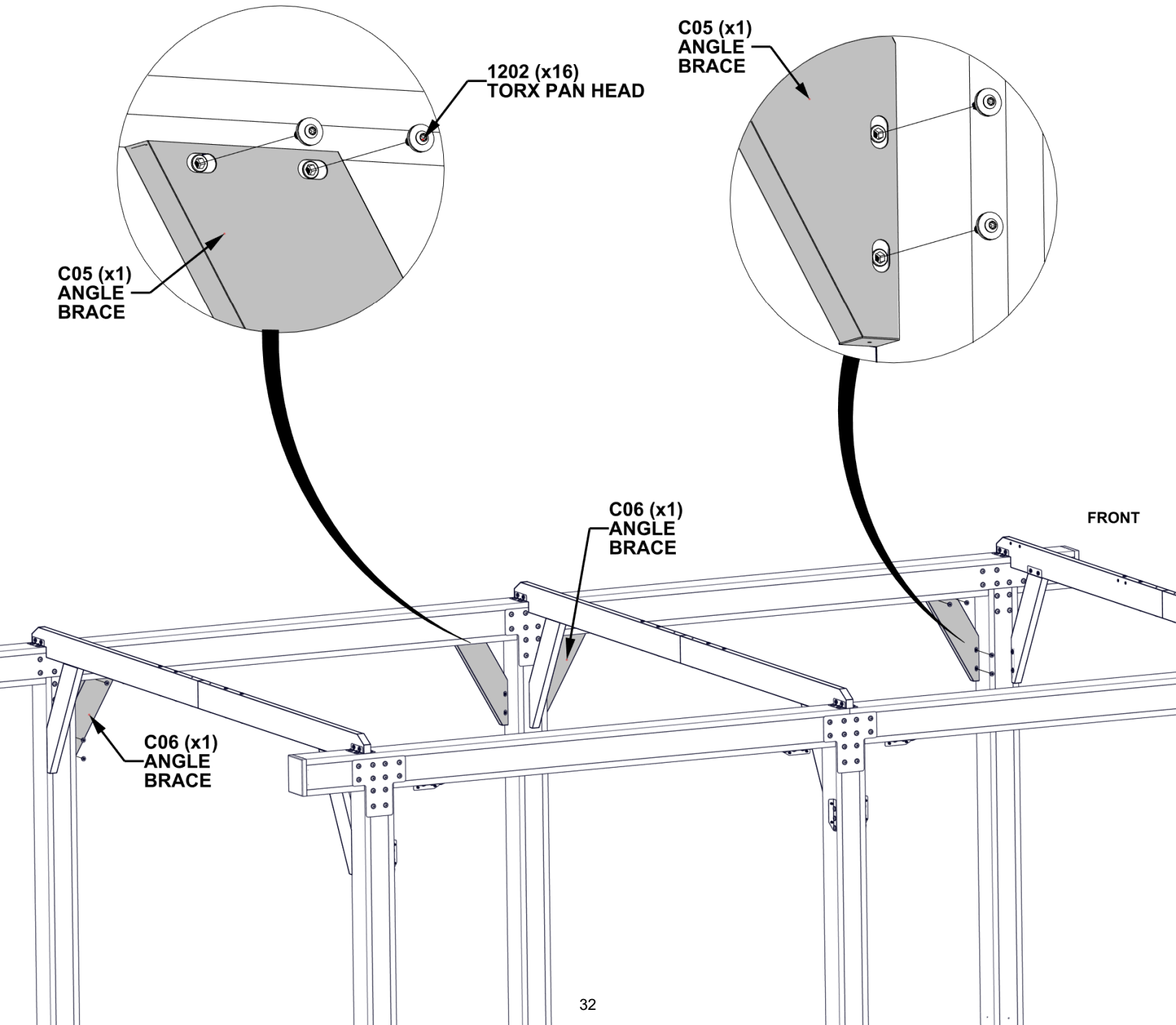

STEP 19 - ANGLE BRACE ASSEMBLY

QTY	PART NUMBER	DESCRIPTION
16	H101202	TORX PAN HEAD 1/4-20x3/4 ASSY

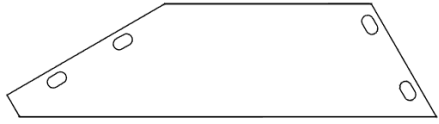

C06 ANGLE BRACE - A4M04321
(x2) 1 7/16"x5 5/16"x20 1/16" (36x135x509)



C05 ANGLE BRACE - A4M04320
(x2) 1 7/16"x5 5/16"x20 1/16" (36x135x509)

- **HAND TIGHTEN UNTIL ALL HARDWARE IS INSERTED, THEN FULLY TIGHTEN.**
- ALIGN BRACKET WITH PILOT HOLES IN POST AS SHOWN.

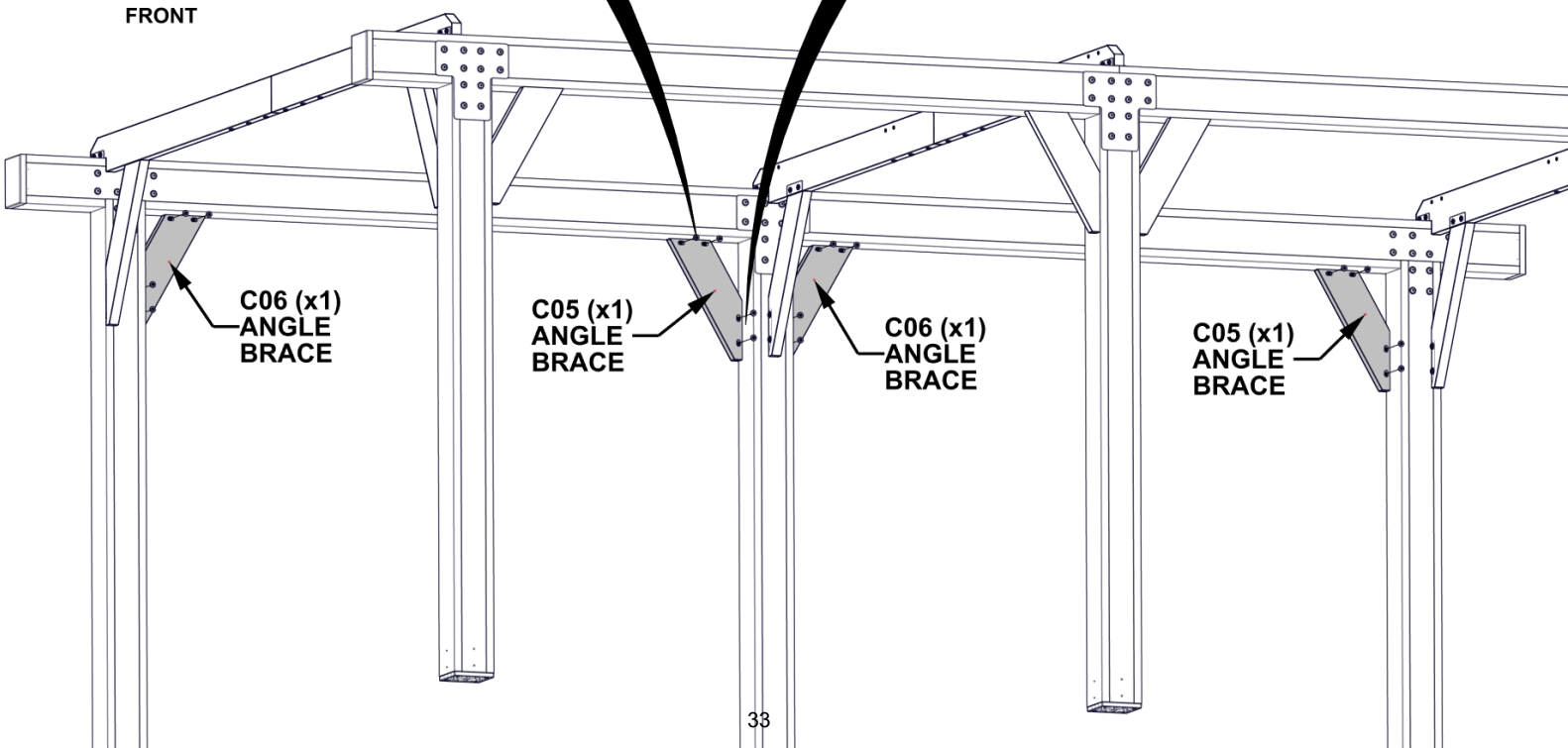
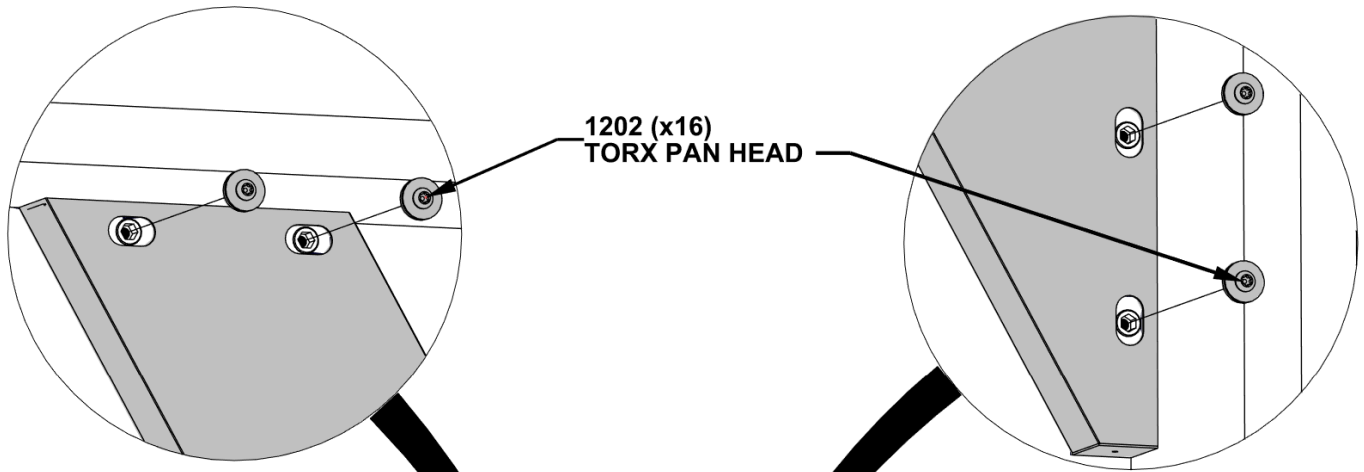

STEP 20 - GABLE ASSEMBLY

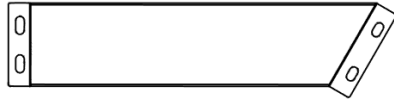

B08 GABLE SUPPORT - A4M04318
(x3) 1 1/2"x5 15/16"x24 5/8" (38x152x625)

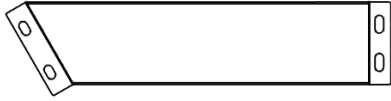

B09 GABLE SUPPORT - A4M04319
(x3) 1 1/2"x5 15/16"x24 5/8" (38x152x625)

QTY	PART NUMBER	DESCRIPTION
18	H101202	TORX PAN HEAD 1/4-20x3/4 ASSY

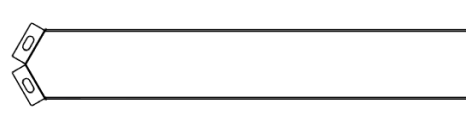

B07 VERTICAL GABLE SUPPORT - A4M04317
(x3) 1 1/2"x9 1/16"x34 11/16" (38x230x882)

- **HAND TIGHTEN HARDWARE.**
- ALIGN COMPONENTS WITH THREADED INSERTS.

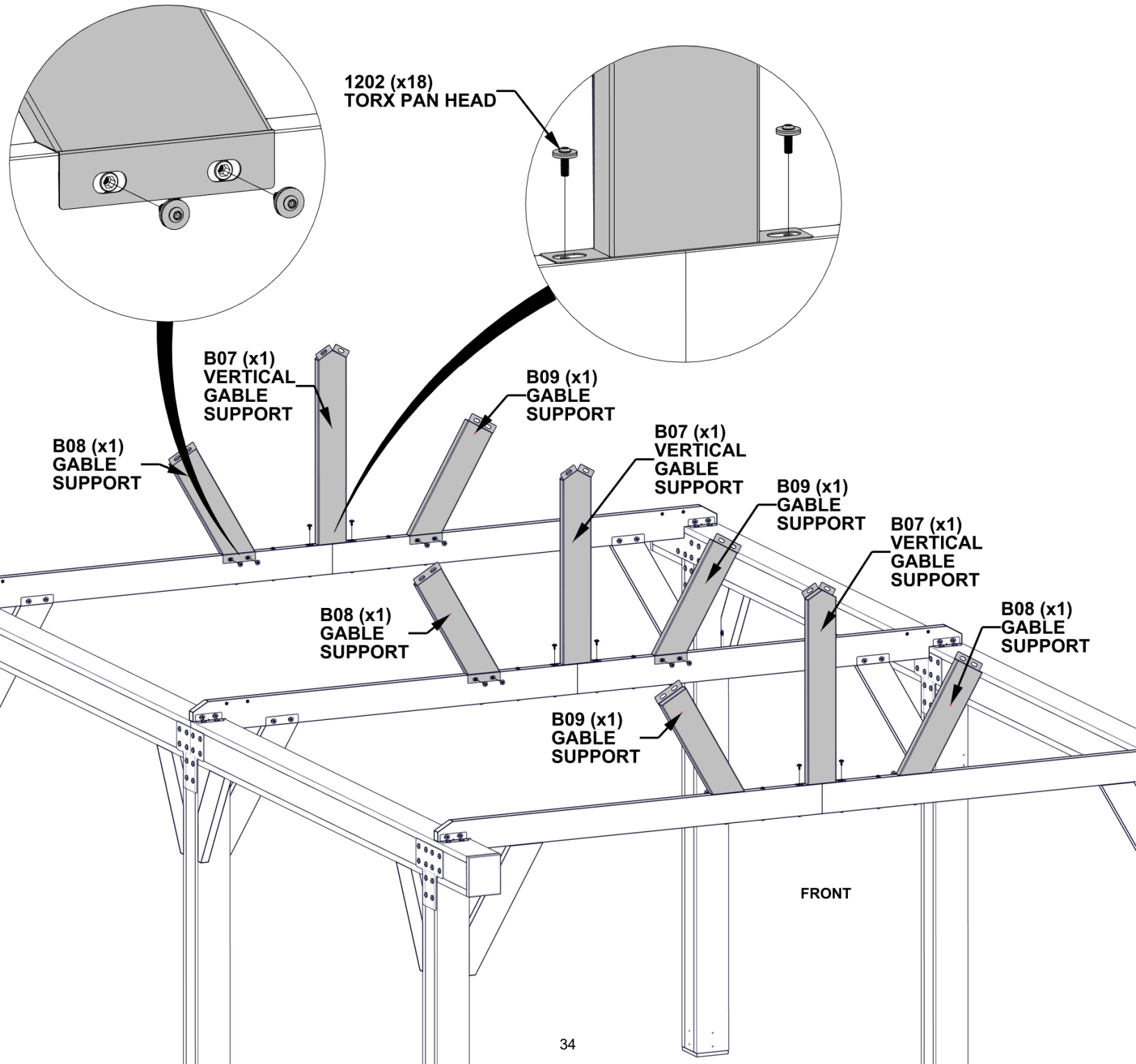

STEP 21 - GABLE ASSEMBLY

QTY	PART NUMBER	DESCRIPTION
20	H101202	TORX PAN HEAD 1/4-20x3/4 ASSY

B03 GABLE BEAM - A4M04157
(x2) 1 1/2"x5 1/4"x79 1/2" (38x134x2019)

B04 GABLE BEAM - A4M04158
(x2) 1 1/2"x5 1/4"x79 1/2" (38x134x2019)

- HAND TIGHTEN HARDWARE.

- ALIGN COMPONENTS WITH THREADED INSERTS.

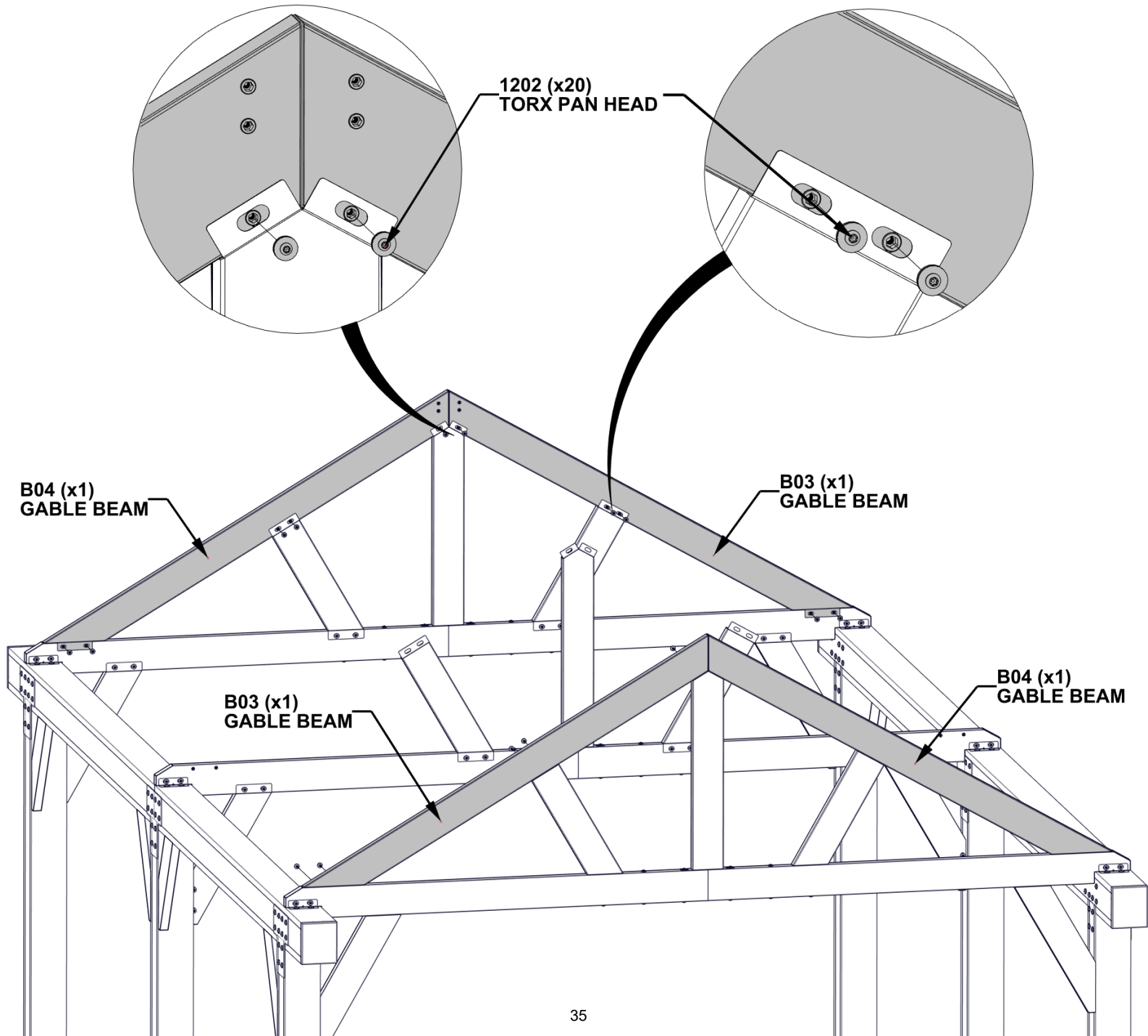

STEP 22 - GABLE ASSEMBLY

QTY	PART NUMBER	DESCRIPTION
10	H101202	TORX PAN HEAD 1/4-20x3/4 ASSY

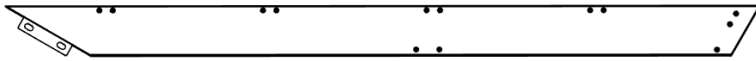

B05 GABLE BEAM - A4M05403
(x1) 1 1/2"x5 1/4"x79 1/2" (38x134x2019)

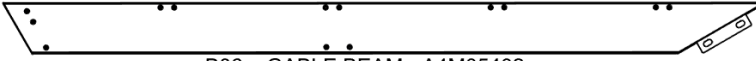

B06 GABLE BEAM - A4M05402
(x1) 1 1/2"x5 1/4"x79 1/2" (38x134x2019)

- **HAND TIGHTEN HARDWARE.**
- ALIGN COMPONENTS WITH THREADED INSERTS.

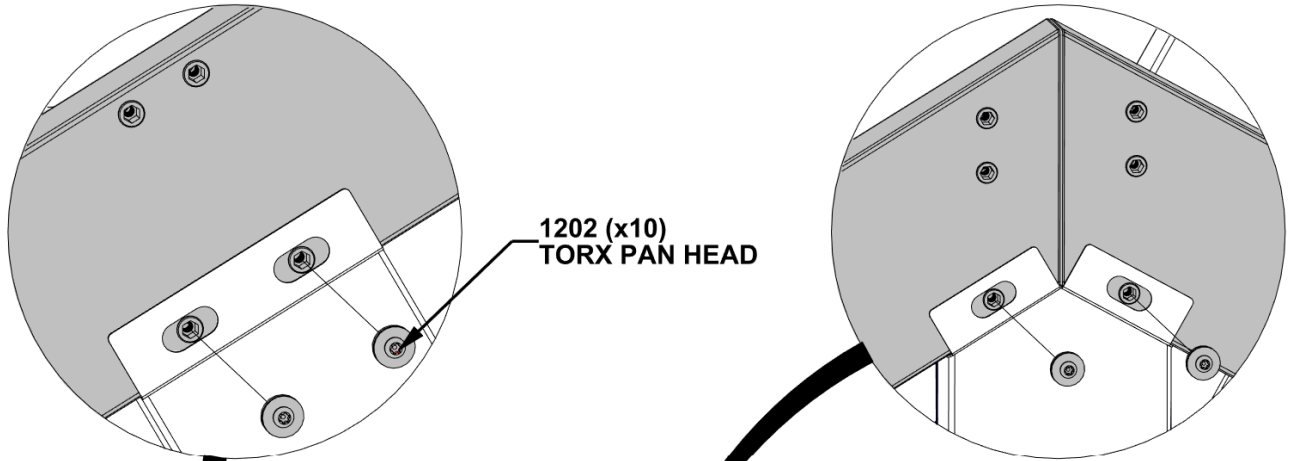

1202 (x10)
TORX PAN HEAD

B05 (x1)
GABLE BEAM

B06 (x1)
GABLE BEAM

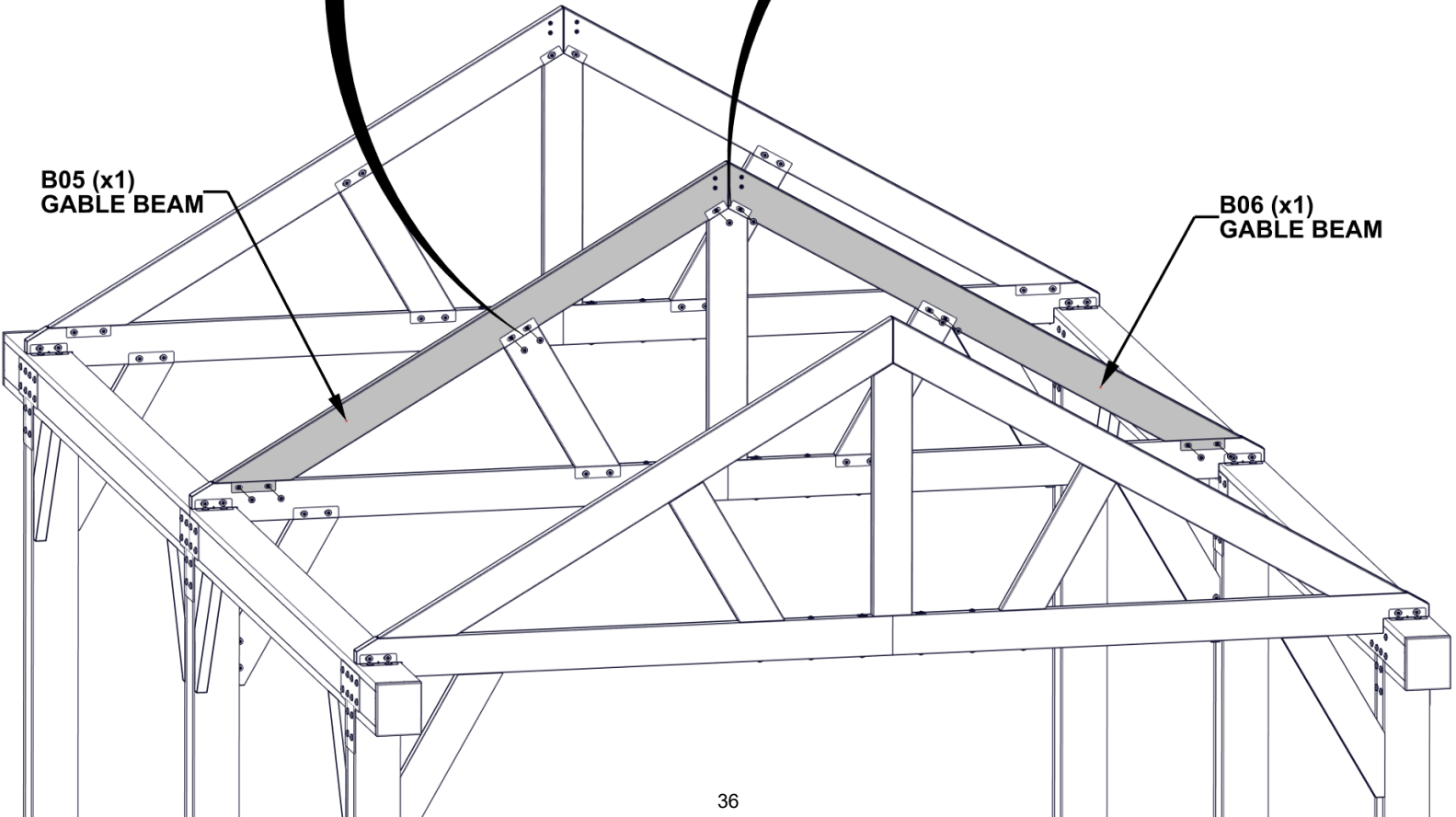

STEP 23 - GABLE ASSEMBLY

QTY	PART NUMBER	DESCRIPTION
16	H101202	TORX PAN HEAD 1/4-20x3/4 ASSY

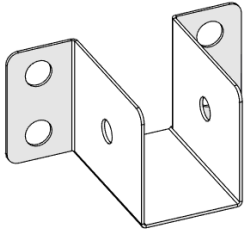

A4M04905 RIDGE CLIP
(x4)

- **HAND TIGHTEN HARDWARE, THEN FULLY TIGHTEN ALL HARDWARE.**
- ALIGN COMPONENTS WITH THREADED INSERTS.

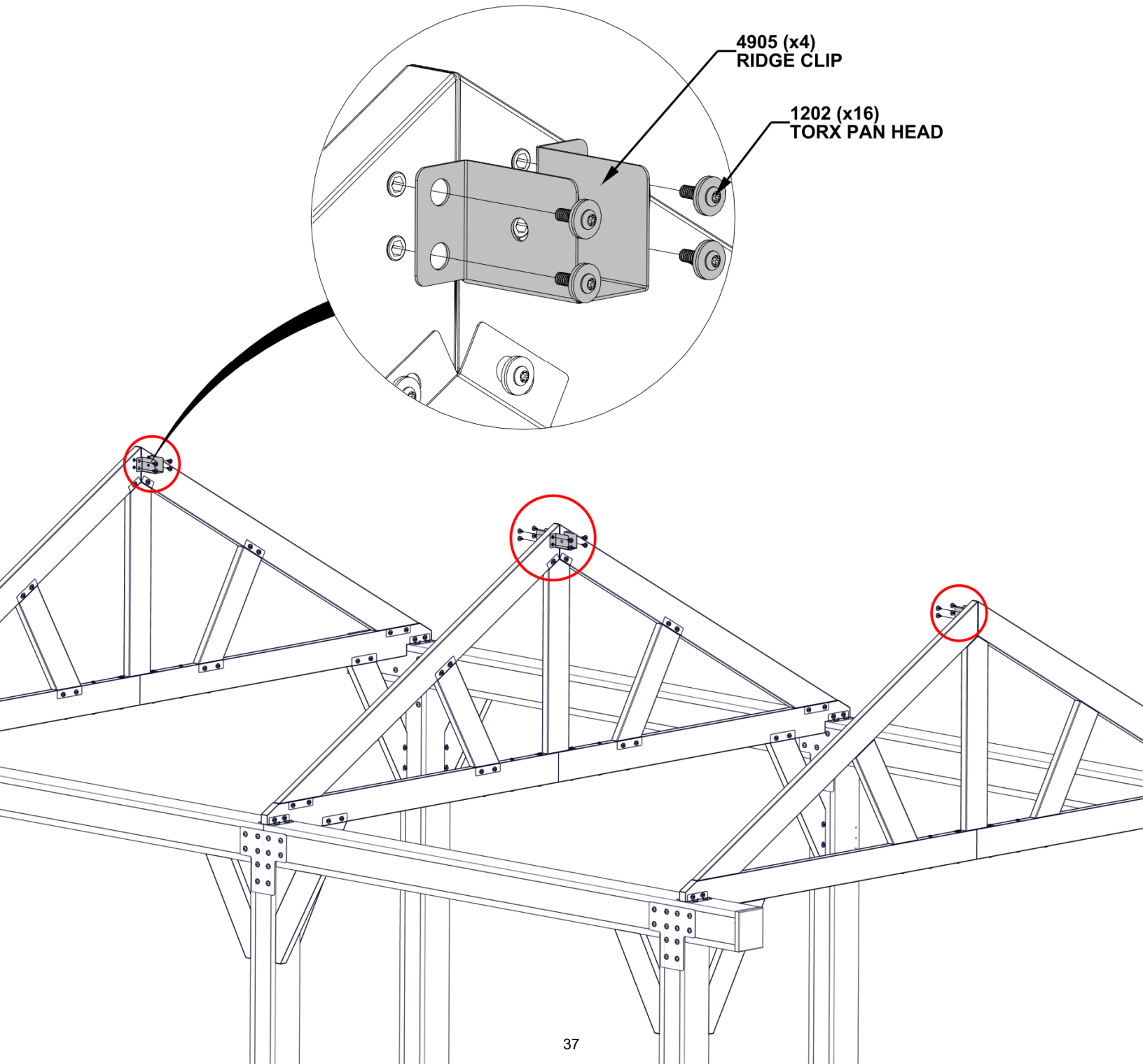

4905 (x4)
RIDGE CLIP

1202 (x16)
TORX PAN HEAD

STEP 24A - RIDGE ASSEMBLY

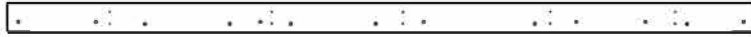

AD02 PEAK SUPPORT - W4L22014
(x1) 15/16"x4"x98 13/16" (24x102x2510)



AD04 PEAK SUPPORT - W4L21848
(x1) 15/16"x4"x98 13/16" (24x102x2510)



A4M05605 RIDGE PLATE
(x1)

QTY	PART NUMBER	DESCRIPTION
5	H100379	TNUT-5/16" BLK
10	H100382	SCREW PFH 8x1 3/4 BLK

- INSERT T-NUTS FIRST.

- ALIGN HOLES IN AD02 BOARD AND 5605 RIDGE PLATE WITH PILOT HOLES IN AD04 BOARD.
- SET ASIDE FOR LATER USE.

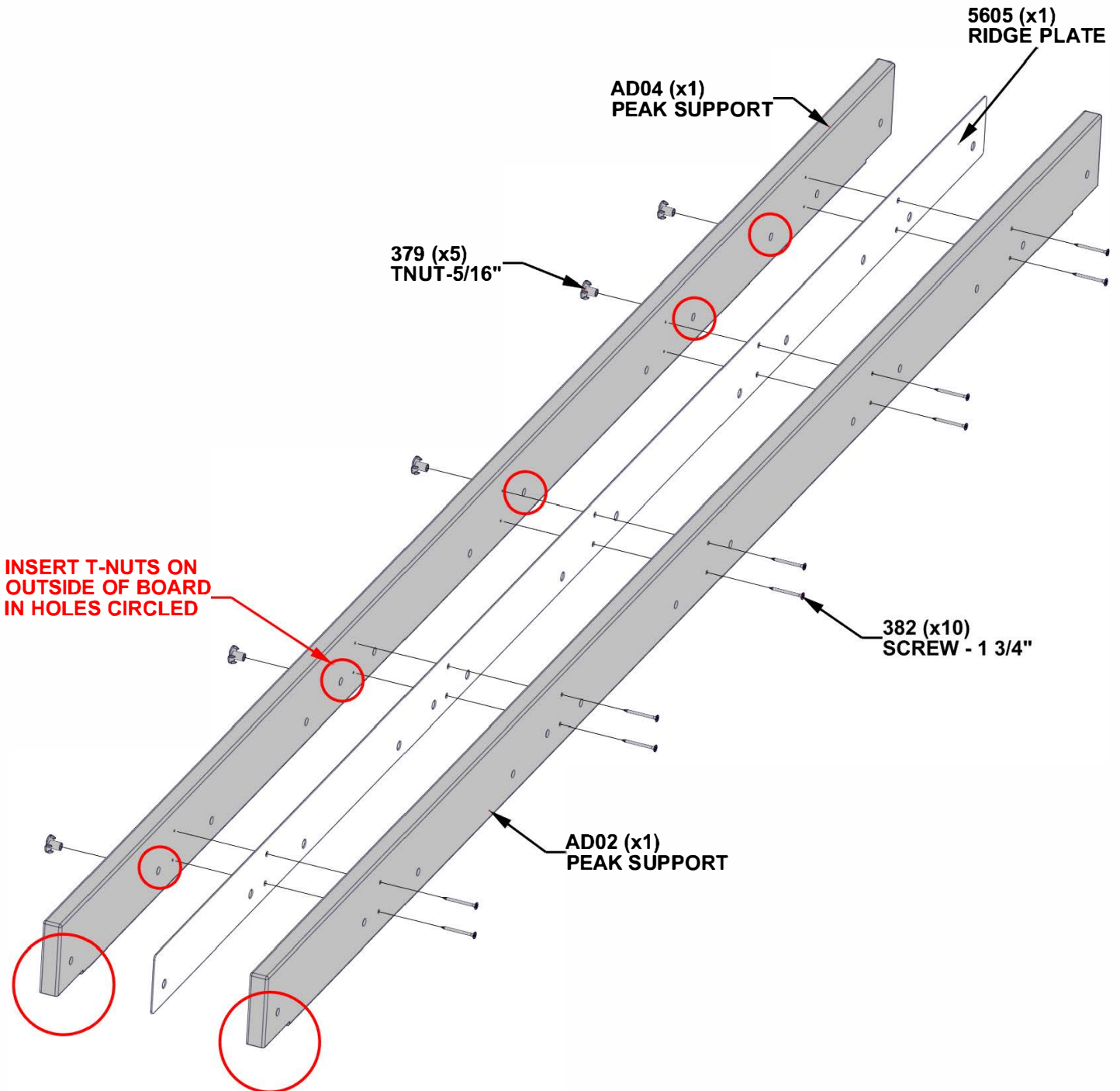

NOTE ORIENTATION OF NOTCHES IN BOARDS

STEP 24B - RIDGE ASSEMBLY

QTY	PART NUMBER	DESCRIPTION
5	H100379	TNUT-5/16" BLK
10	H100382	SCREW PFH 8x1 3/4 BLK

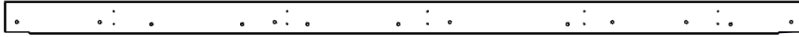

AD02 PEAK SUPPORT - W4L22014
(x1) 15/16"x4"x98 13/16" (24x102x2510)

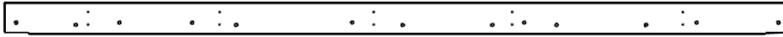

AD05 PEAK SUPPORT - W4L22017
(x1) 15/16"x4"x98 13/16" (24x102x2510)

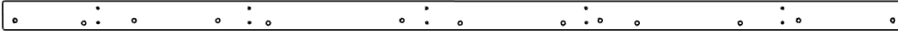

A4M05605 RIDGE PLATE
(x1)

- INSERT T-NUTS FIRST.

- ALIGN HOLES IN AD02 AND 5605 RIDGE PLATE WITH PILOT HOLES IN AD05 BOARD.
- SET ASIDE FOR LATER USE, KEEP SEPERATE FROM PREVIOUS STEP ASSEMBLY.

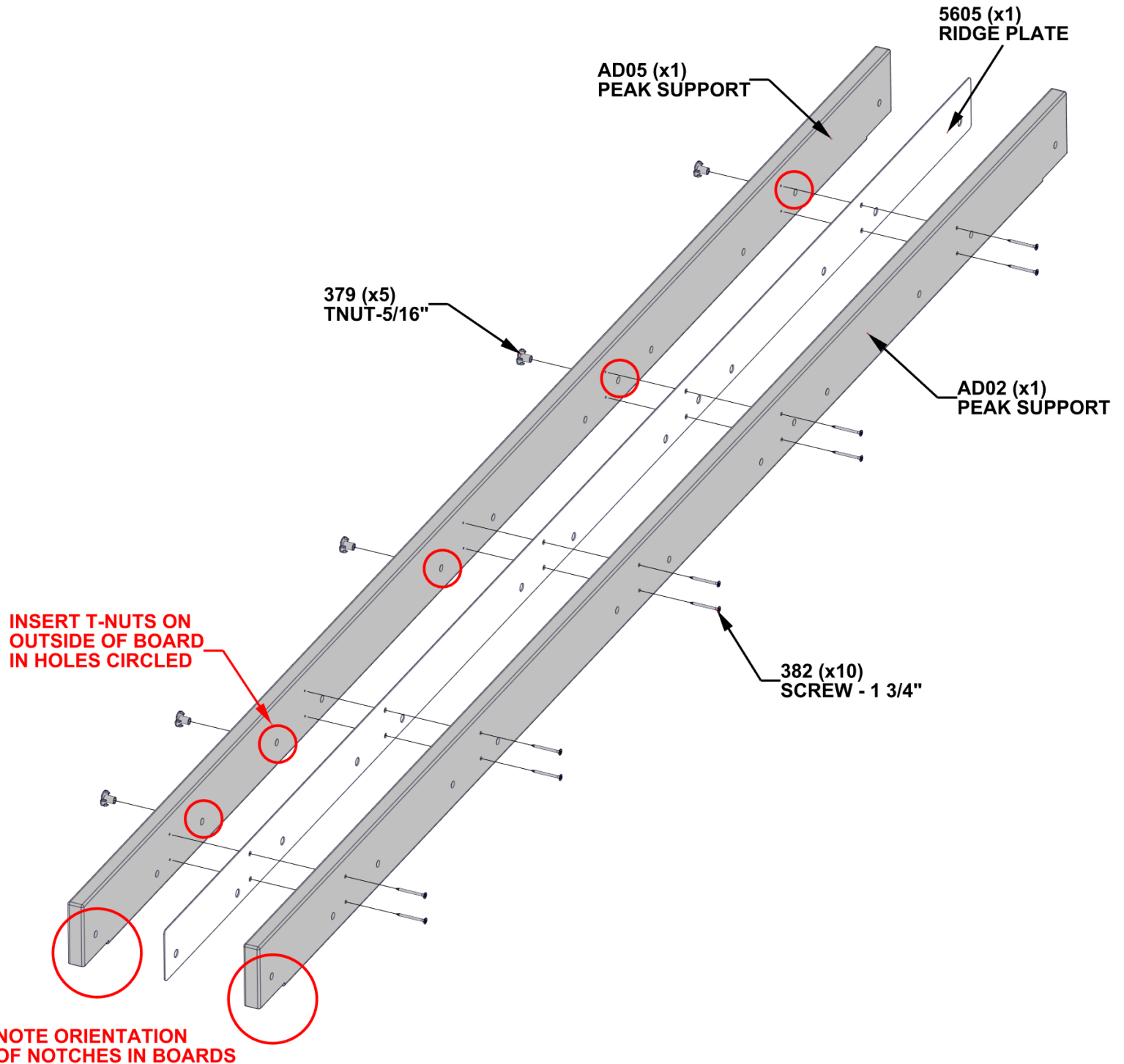

STEP 25 - RIDGE ASSEMBLY

QTY	PART NUMBER	DESCRIPTION
4	H100195	BOLT WH 5/16x2 3/4 BLK
4	H100478	WASHER FLAT 8x27 BLK
4	H100479	NUT LOCK 5/16 BLK

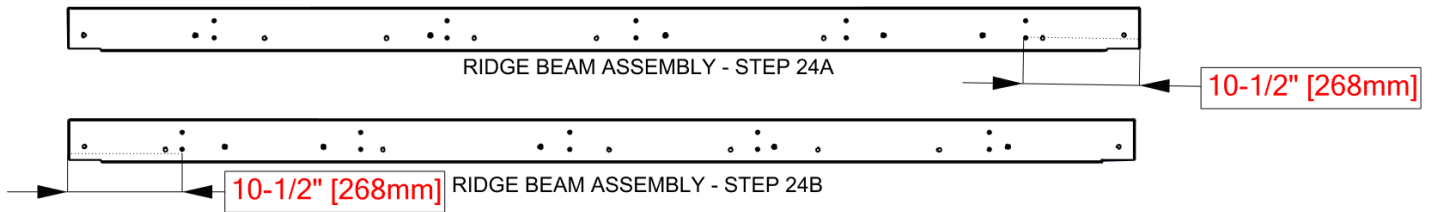

- NOTE ORIENTATION OF RIDGE BEAM ASSEMBLIES. MEASURED END WILL BE INSTALLED TOWARD MIDDLE GABLE ASSEMBLY AS SHOWN.

- ALIGN HOLES IN RIDGE PEAK ASSEMBLY FROM PREVIOUS STEP WITH HOLES IN RIDGE CLIP BRACKET.
- FULLY TIGHTEN HARDWARE.

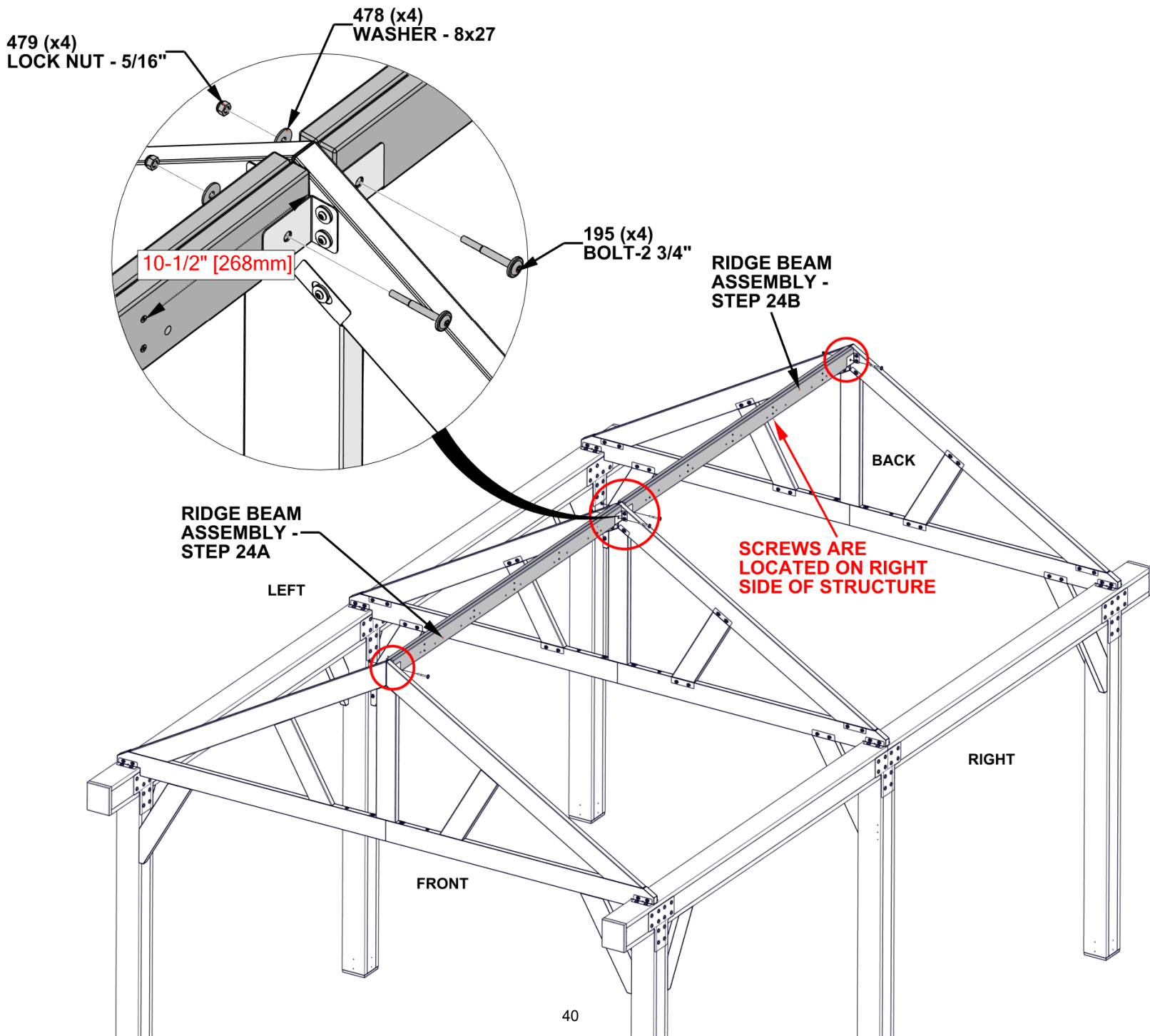

STEP 26A - ROOF PANEL 'A' ASSEMBLY

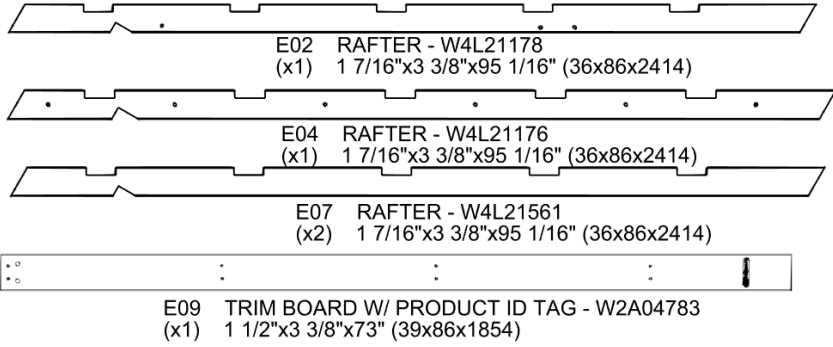

QTY	PART NUMBER	DESCRIPTION
8	H100201	SCREW PFH 8x2 1/2 BLK
2	H100379	T-NUT 5/16 BLK
8	H100391	SCREW PFH 8x2 BLK

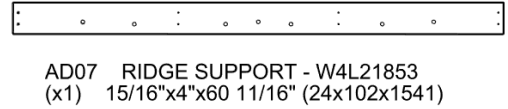

- INSERT T-NUTS FIRST, FAILURE TO DO SO WILL RESULT IN INCORRECT ASSEMBLY.

- ALIGN AD07 AND E09 WITH PILOT HOLES IN RAFTER BOARDS.
- NOTE ORIENTATION OF AD07 BOARD, HOLES ARE TOWARD THE BOTTOM OF BOARD.
- TO HELP WITH ORGANIZATION, WE SUGGEST LABELING 'S1A' ON THE SCREW SIDE OF AD07 RIDGE SUPPORT TO KEEP TRACK OF SECTION 1, PANEL A.

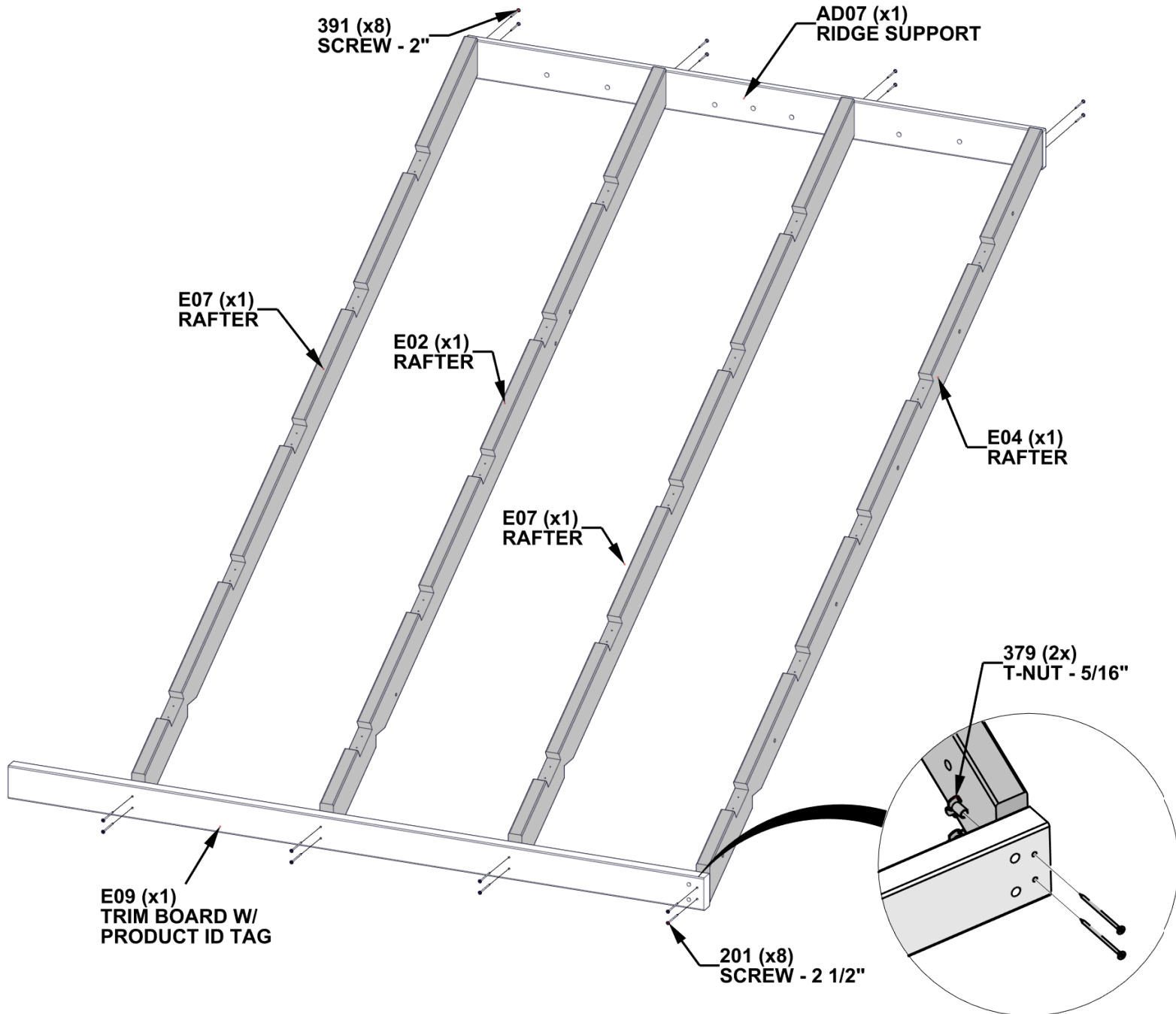

DO NOT OVERTIGHTEN H100201 SCREWS

STEP 26B - ROOF PANEL 'A' ASSEMBLY

E04	RAFTER - W4L21176
(x2)	1 7/16"x3 3/8"x95 1/16" (36x86x2414)
E02	RAFTER - W4L21178
(x2)	1 7/16"x3 3/8"x95 1/16" (36x86x2414)
E07	RAFTER - W4L21561
(x2)	1 7/16"x3 3/8"x95 1/16" (36x86x2414)
E06	TRIM BOARD - W4L22012
(x1)	1 9/16"x3 3/8"x71 5/8" (36x86x1820)

QTY	PART NUMBER	DESCRIPTION
12	H100201	SCREW PFH 8x2 1/2 BLK
4	H100379	T-NUT 5/16 BLK
12	H100391	SCREW PFH 8x2 BLK

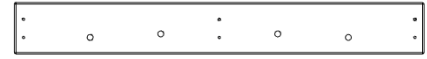

AD01 RIDGE SUPPORT - W4L22008
(x2) 15/16"x4"x31 15/16" (24x102x812)

- **INSERT T-NUTS FIRST. FAILURE TO DO SO WILL RESULT IN INCORRECT ASSEMBLY.**
- ALIGN AD01 AND E06 WITH PILOT HOLES IN RAFTER BOARDS.
- NOTE ORIENTATION OF AD01 BOARDS, HOLES ARE TOWARD THE BOTTOM OF BOARD.
- TO HELP WITH ORGANIZATION, WE SUGGEST LABELING 'S2A' ON THE SCREW SIDE OF AD01 PEAK SUPPORT TO KEEP TRACK OF SECTION 2, PANEL A.

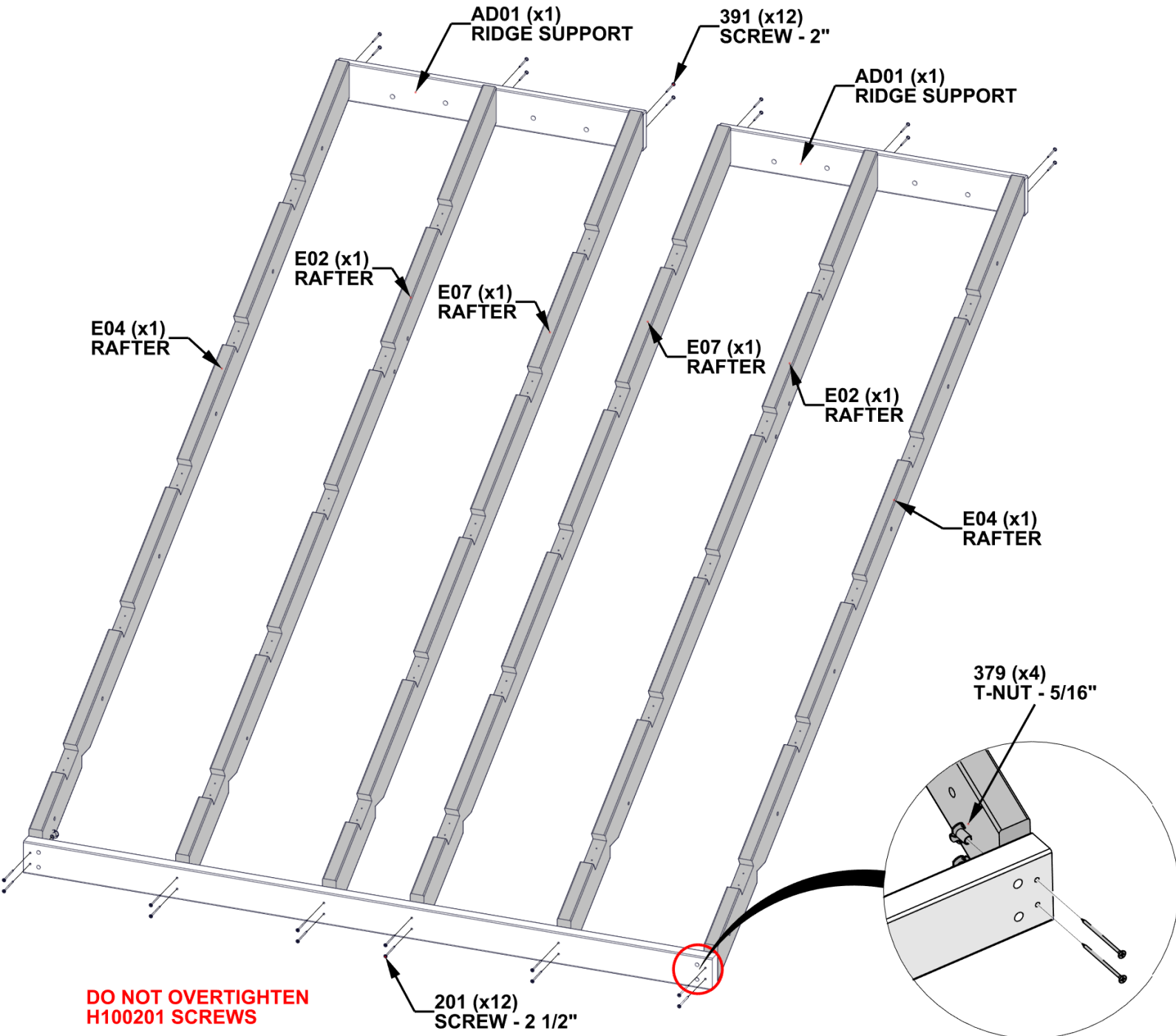

**DO NOT OVERTIGHTEN
H100201 SCREWS**

STEP 26C - ROOF PANEL 'A' ASSEMBLY

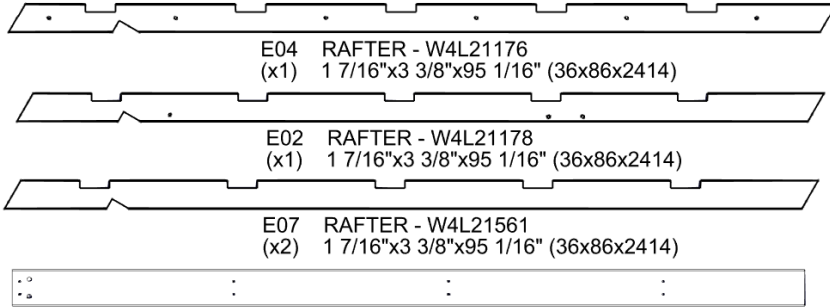

QTY	PART NUMBER	DESCRIPTION
8	H100201	SCREW PFH 8x2 1/2 BLK
2	H100379	T-NUT 5/16 BLK
8	H100391	SCREW PFH 8x2 BLK

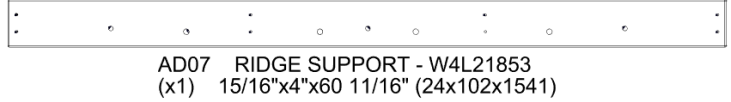

- INSERT T-NUTS FIRST, FAILURE TO DO SO WILL RESULT IN INCORRECT ASSEMBLY.

- ALIGN AD07 AND E05 WITH PILOT HOLES IN RAFTER BOARDS.
- NOTE ORIENTATION OF AD07 BOARD, HOLES ARE TOWARD THE BOTTOM OF BOARD.
- TO HELP WITH ORGANIZATION, WE SUGGEST LABELING 'S3A' ON THE SCREW SIDE OF AD07 RIDGE SUPPORT TO KEEP TRACK OF SECTION 3, PANEL A.

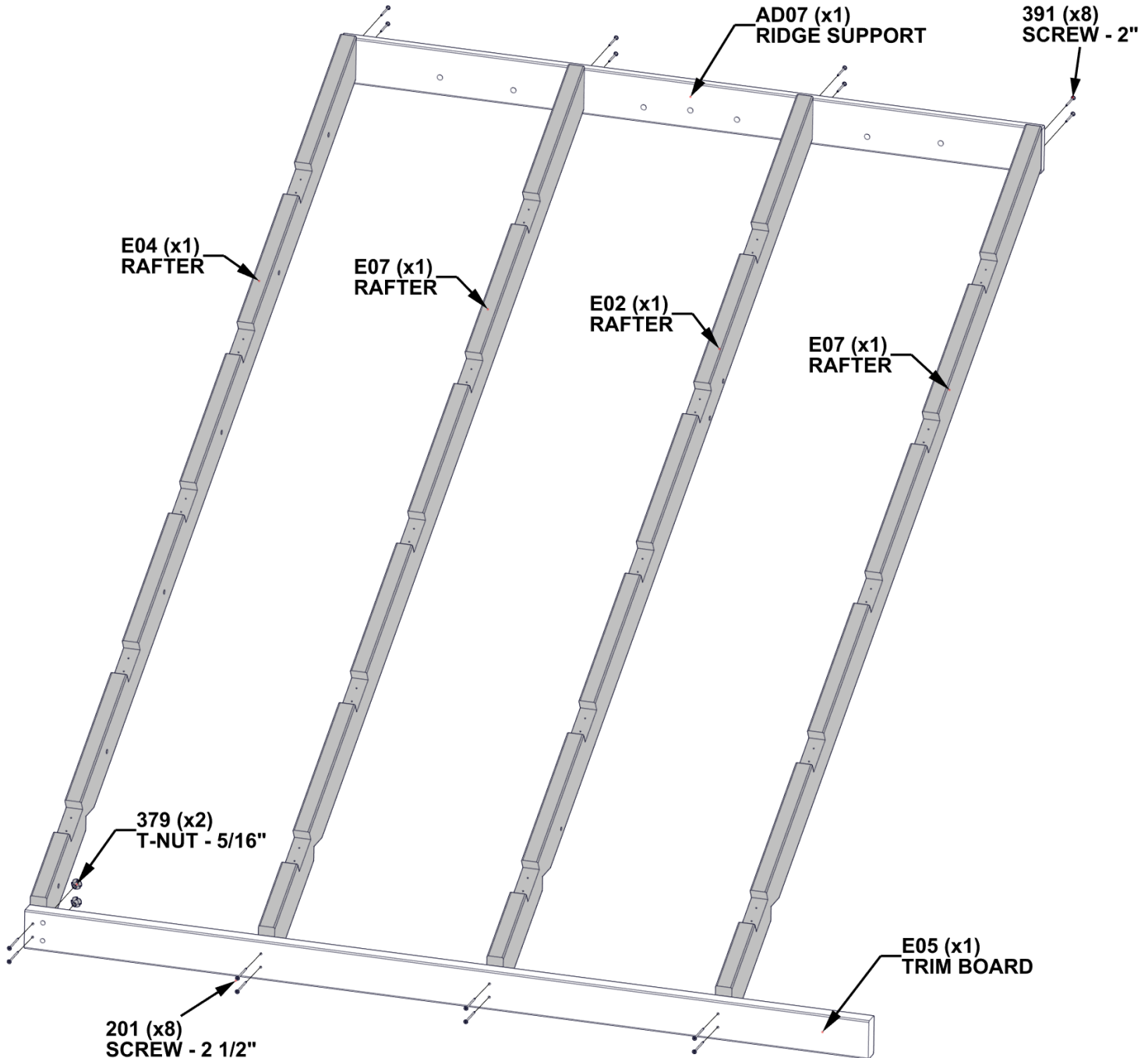

DO NOT OVERTIGHTEN H100201 SCREWS

STEP 26D - ROOF PANEL 'A' ASSEMBLY

QTY	PART NUMBER	DESCRIPTION
12	H100198	WASHER LOCK EXT 8x19
12	H100478	WASHER FLAT 8x27 BLK
12	H100479	NUT LOCK 5/16 BLK
12	H100503	BOLT WH 5/16x3 1/2 BLK

- ALIGN HOLES IN MIDDLE RAFTERS AND FASTEN HARDWARE AS SHOWN.

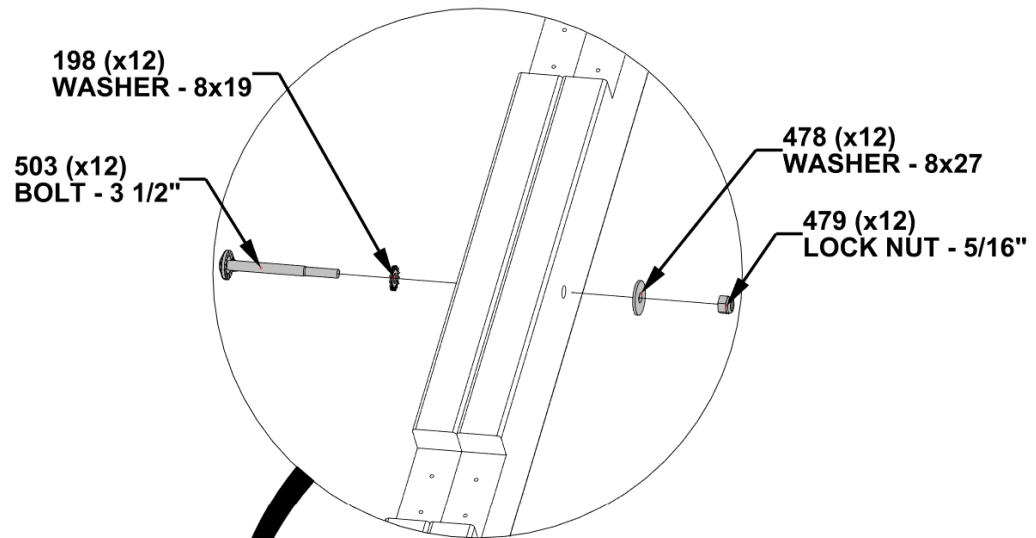

PEAK

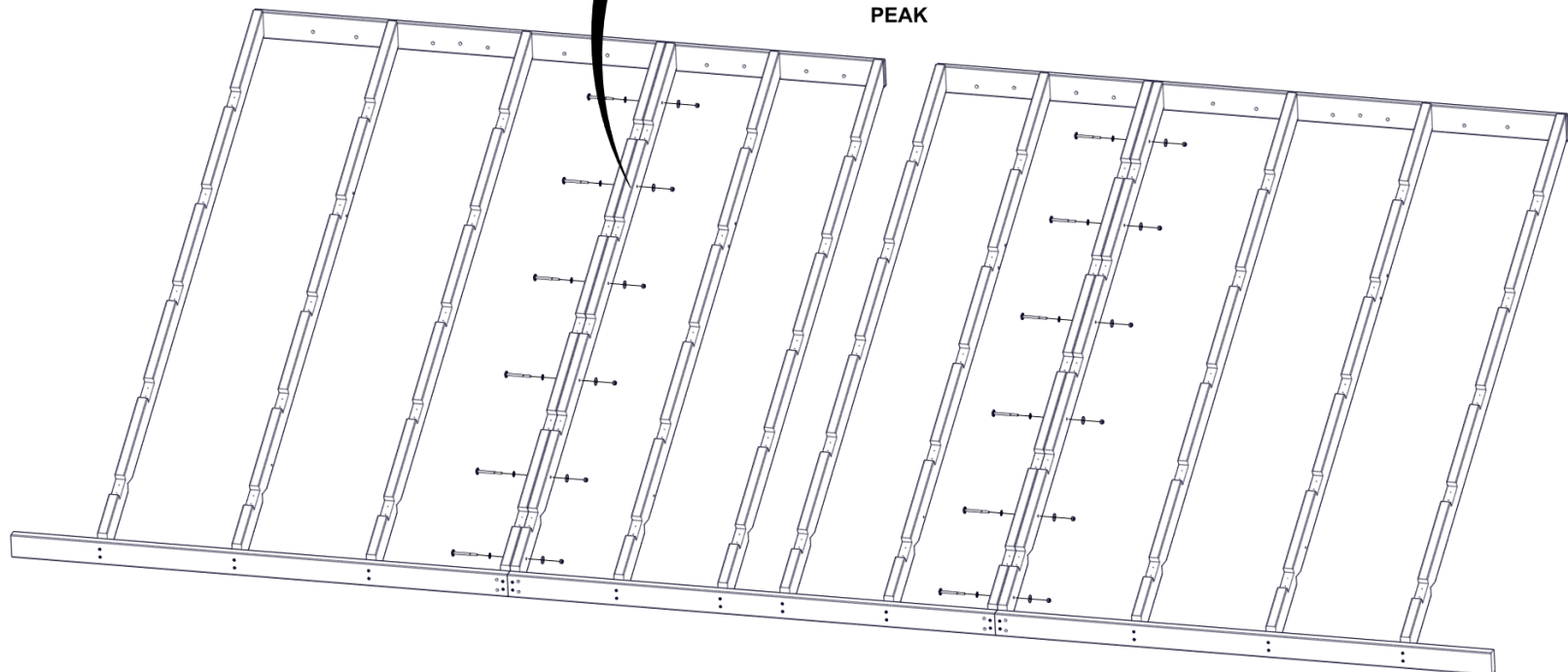

STEP 26E - ROOF PANEL 'A' ASSEMBLY

QTY	PART NUMBER	DESCRIPTION
20	H100171	BOLT WH 1/4x1 BLK
20	H100398	TNUT-1/4" BLK



H01 PURLIN - W4L21856
(x10) 15/16"x3 3/8"x72 15/16" (24x86x1852)

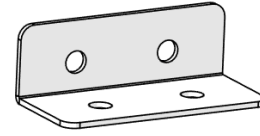

A4M04154 PURLIN SUPPORT BRACKET
(x10)

- INSERT T-NUTS FIRST.

- LONG SECTION OF 4154 BRACKET ATTACHES TO H01 PURLIN.
- COMPLETE THIS STEP 10 TIMES.

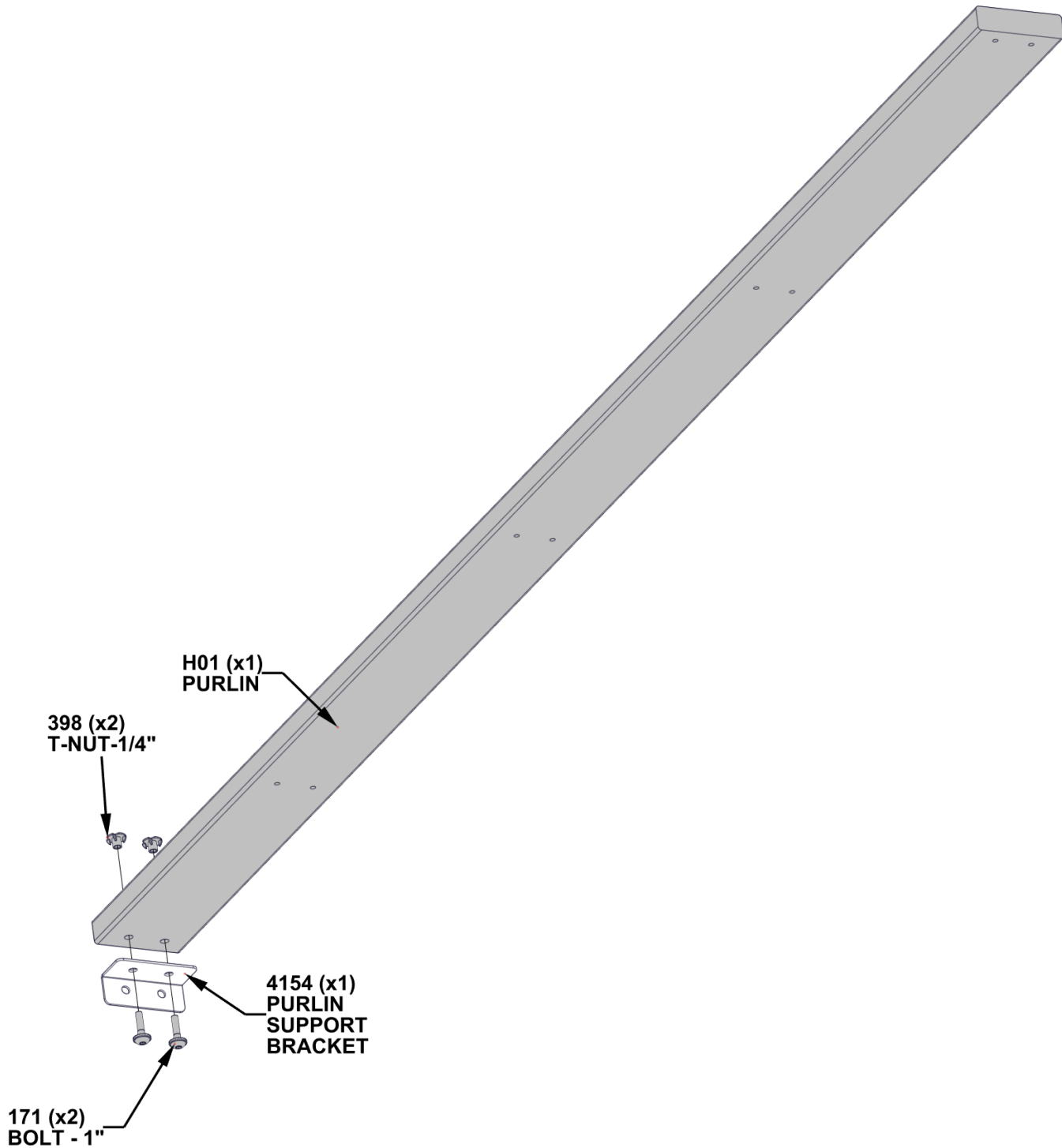

STEP 26F - ROOF PANEL 'A' ASSEMBLY

QTY	PART NUMBER	DESCRIPTION
140	H100391	SCREW PFH 8x2 BLK



H07 PURLIN - W4L22007
(x5) 15/16"x3 3/8"x71 9/16" (24x86x1818)

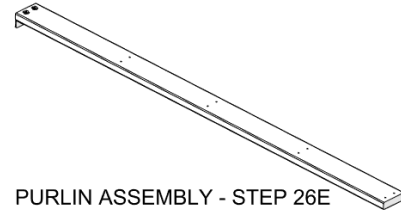

H01 PURLIN ASSEMBLY - STEP 26E
(x10)

- ALIGN PURLINS WITH PILOT HOLES IN RAFTERS.

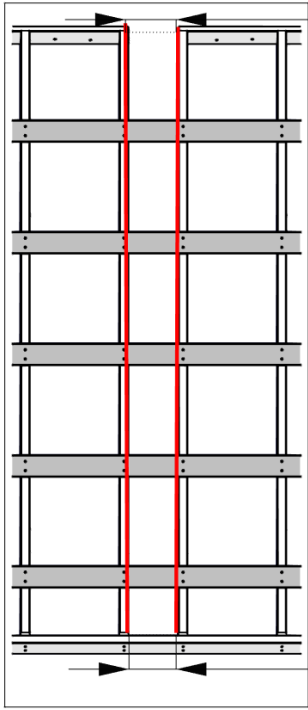

7-11/16" [196mm]

ENSURE THAT THE MIDDLE TWO RAFTERS ARE PARALLEL, THESE DIMENSIONS ARE CRITICAL, FAILURE TO FOLLOW WILL CAUSE ROOF TO BE OUT OF SQUARE AND REMAINING ASSEMBLY WILL NOT LINE UP.

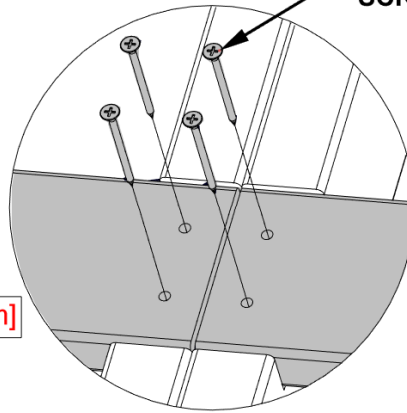

391 (x140)
SCREW - 2"

12-1/4" [312mm]

7-11/16" [196mm]

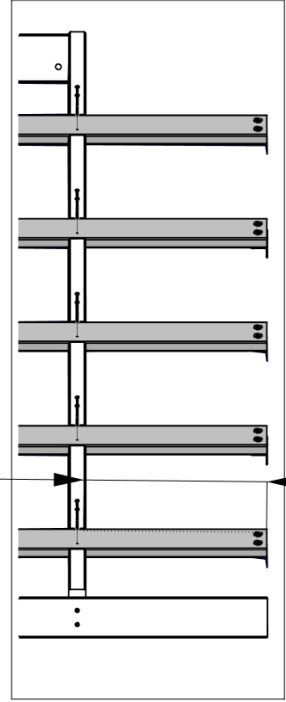

H01 (x5)
PURLIN
ASSEMBLY

OVERHANG DISTANCE FOR PURLINS IS 12-1/4" [312mm] FROM END OF PURLIN TO RAFTER BOARD ON BOTH ENDS.

PEAK

H07 (x5)
PURLIN

H01 (x5)
PURLIN
ASSEMBLY

STEP 26G - ROOF PANEL 'A' ASSEMBLY

QTY	PART NUMBER	DESCRIPTION
6	H100379	T-NUT 5/16 BLK
20	H100460	LAG SCREW WH 1/4x1 BLK

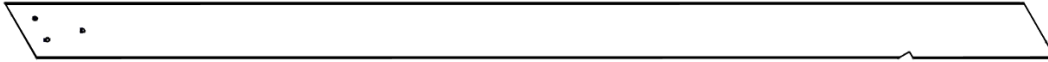

D01 FASCIA - W4L21164
(x1) 1 7/16"x5 1/4"x100" (36x134x2540)



D02 FASCIA - W4L21175
(x1) 1 7/16"x5 1/4"x100" (36x134x2540)

- INSERT T-NUTS FIRST.

- ALIGN D01 AND D02 PILOT HOLES WITH HOLES IN 4154 BRACKETS ATTACHED IN PREVIOUS STEP.

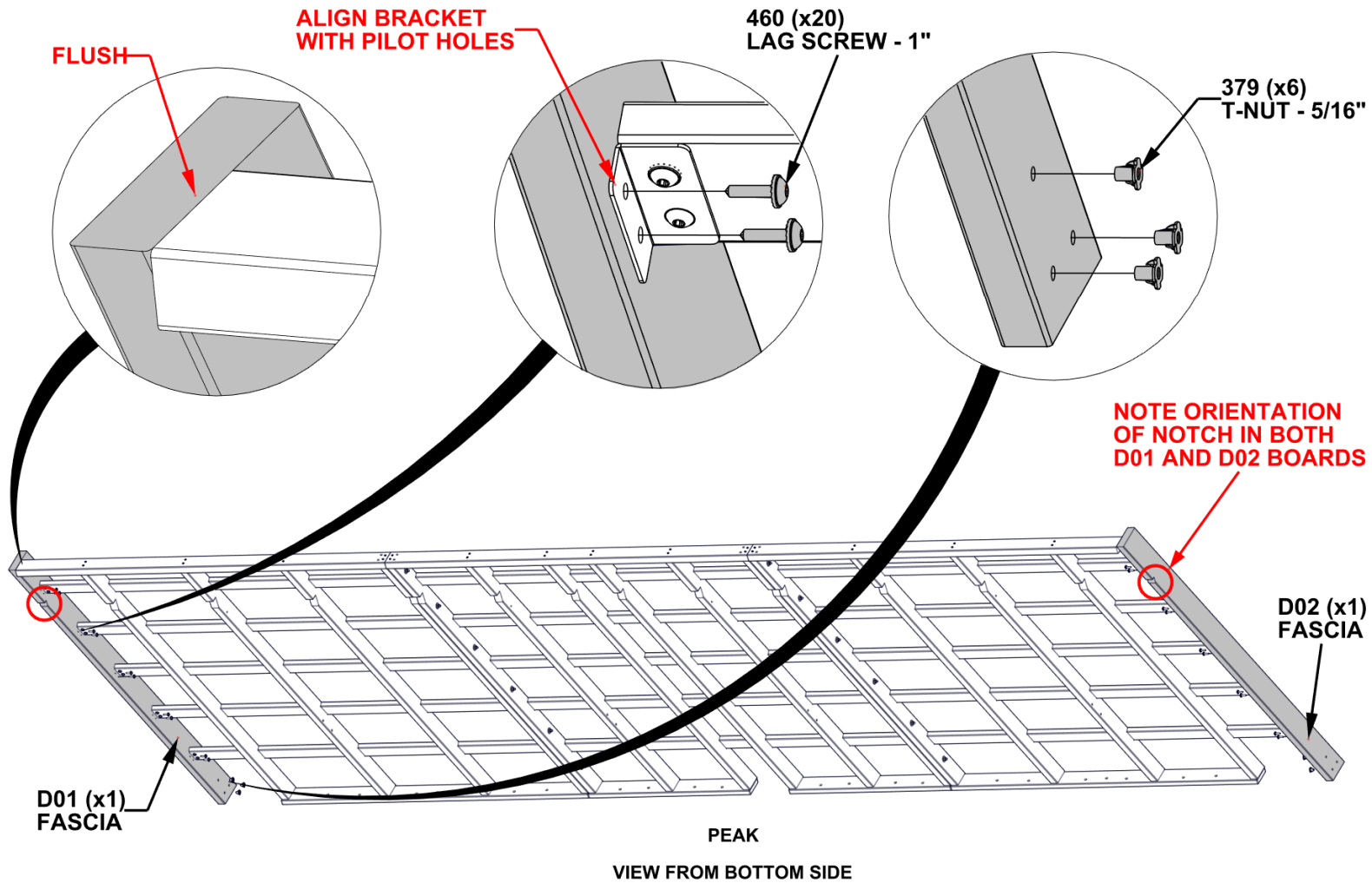

STEP 26H - ROOF PANEL 'A' ASSEMBLY

QTY	PART NUMBER	DESCRIPTION
8	H100797	SCREW PWH 8x1 BLK

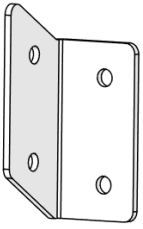

A4M04907 FASCIA BRACKET
(x1)

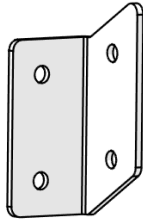

A4M04908 FASCIA BRACKET
(x1)

- **ALIGN BRACKET 1/4" [6mm] FROM TOP OF TRIM BOARD AS SHOWN.**
- ATTACH FASCIA BRACKET 4907 AND 4908 BY DRILLING A 1/8" [3mm] PILOT HOLE AND FASTENING WITH 797 SCREWS.

4907 (x1)
FASCIA BRACKET

**ALIGN BRACKET
1/4" [6mm] FROM
TOP OF BOARD**

797 (x8)
SCREW - 1"

**ALIGN BRACKET
1/4" [6mm] FROM
TOP OF BOARD**

4908 (x1)
FASCIA BRACKET

PEAK

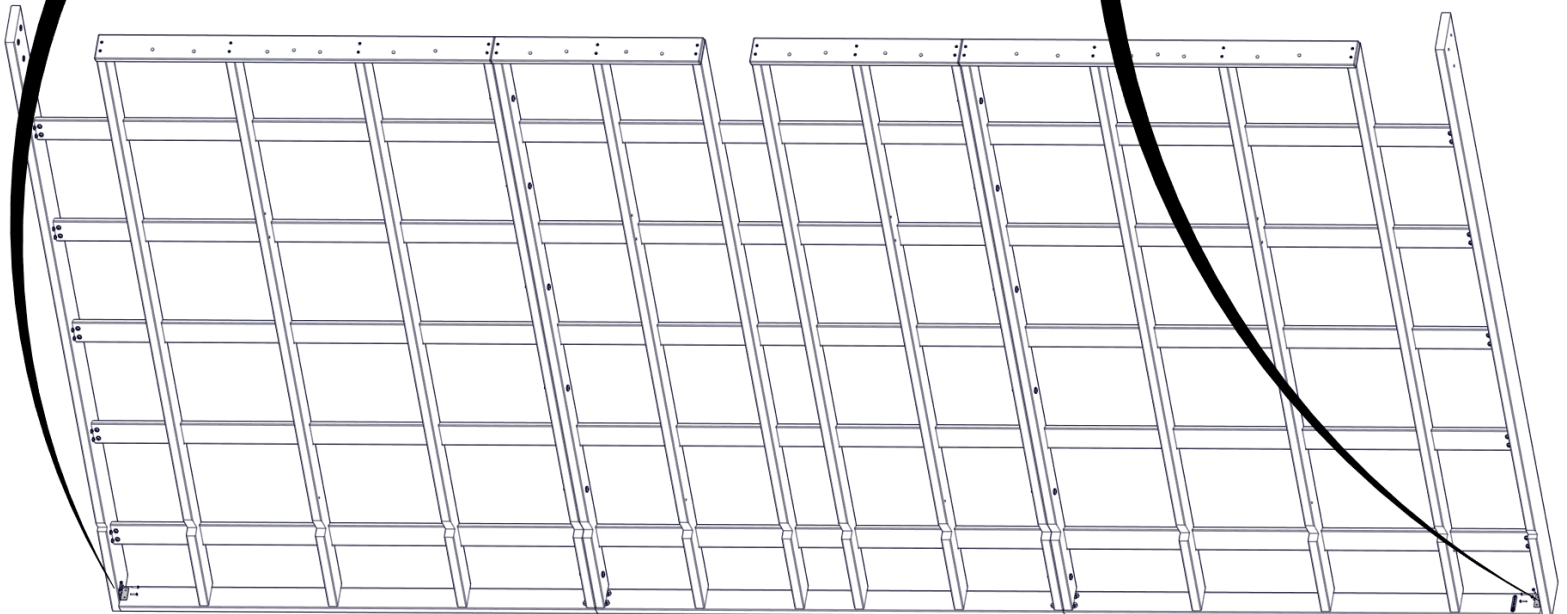

STEP 26I - ROOF PANEL 'A' ASSEMBLY

CRITICAL:

- SQUARE UNIT BEFORE PROCEEDING TO NEXT STEPS.
- THE BELOW DIMENSIONS ARE CRITICAL TO THE FINAL ROOF ASSEMBLY.
- MEASUREMENTS BELOW SHOULD BE HELD WITHIN +/- 1/4" [6mm].
- MEASUREMENTS OUTSIDE OF TOLERANCE WILL LEAD TO THE INABILITY TO ASSEMBLE THE ROOF.

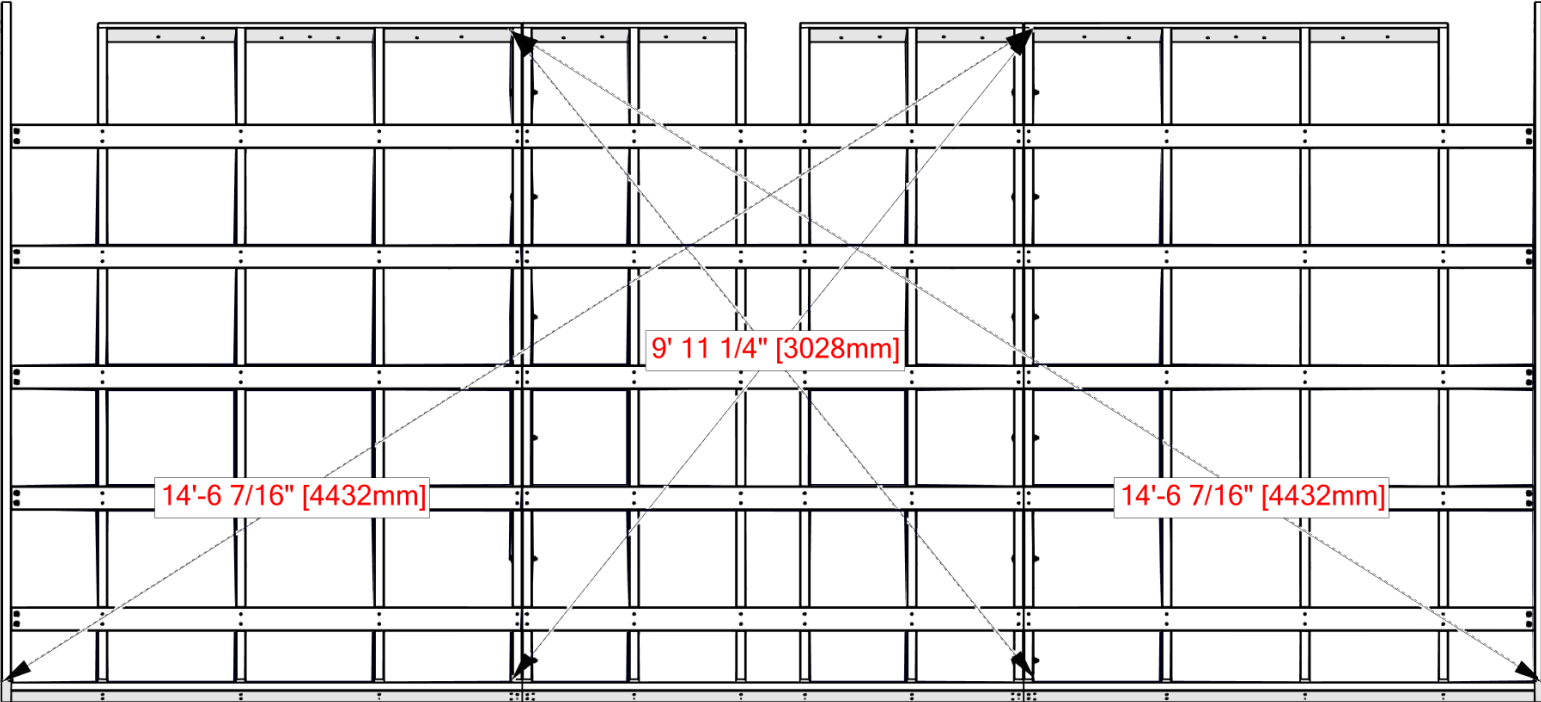

TIP: LOOSEN HARDWARE TO ADJUST FOR SQUARING IF NEEDED.

STEP 27 - ROOF PANEL 'A' ASSEMBLY

- USE THIS PAGE TO FAMILIARIZE YOURSELF WITH THE ROOF PANEL AND ASSIST YOU IN STEPS 28-32.
- REMOVE PROTECTIVE BLUE FILM.
- START AT THE END INDICATED AND ASSEMBLE IN THE DIRECTION OF THE ARROW.

- **GLOVES SHOULD BE WORN WHEN HANDLING ROOF PANELS: EDGES ARE SHARP.**
- **START BY PLACING FIRST SHEET 1/8" [3mm] FROM D01 FASCIA BOARD, THEN MARK WHERE EVERY OTHER SHEET WILL LAND AS SHOWN BELOW TO ENSURE THE PANELS WILL ALIGN CORRECTLY. THE LAST SHEET SHOULD ALIGN CLOSE TO THE EDGE OF D02 FASCIA BOARD.**

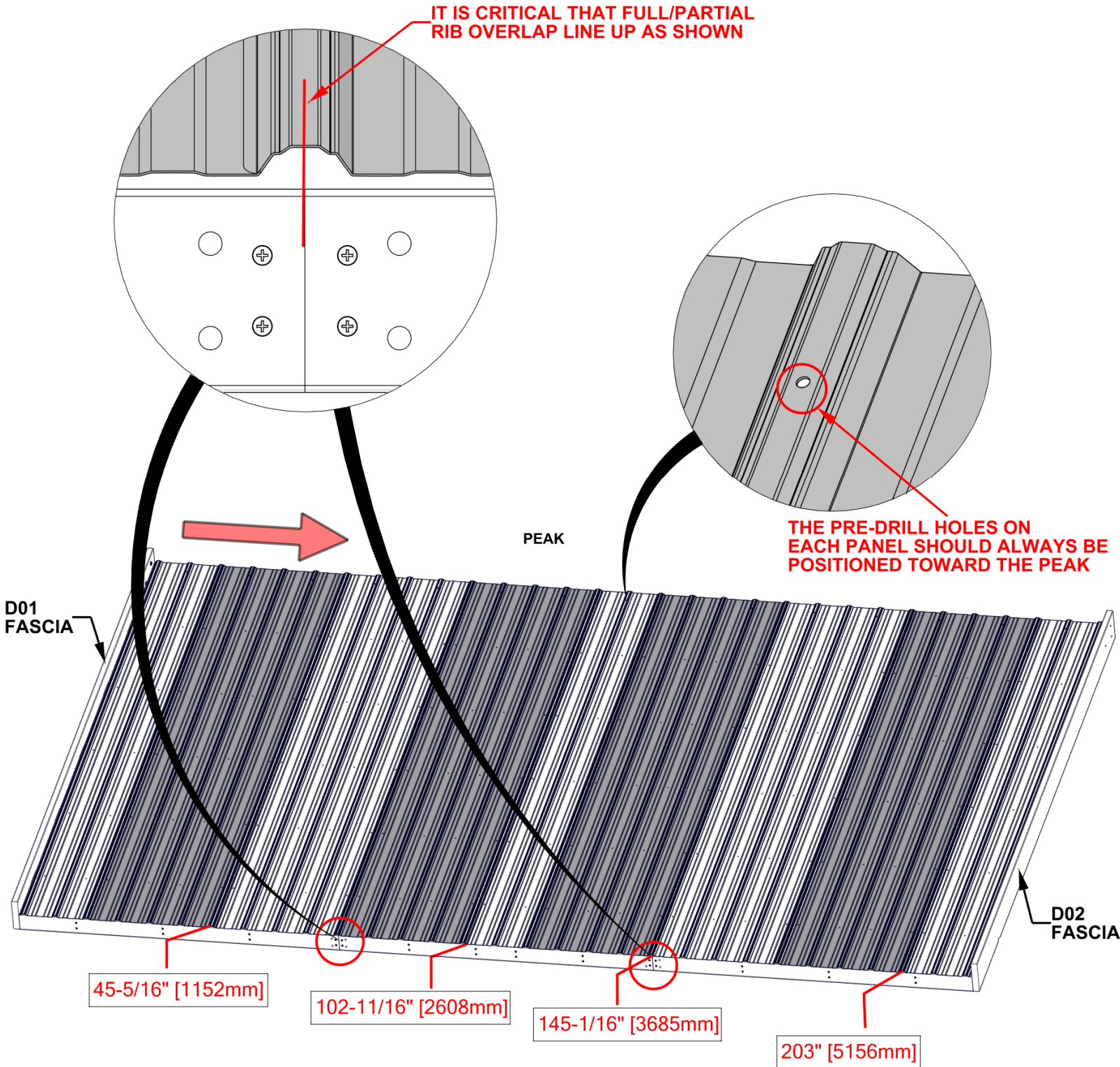

STEP 28 - ROOF PANEL 'A' ASSEMBLY

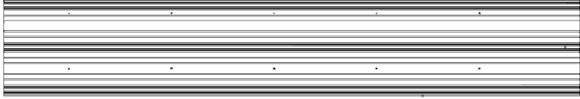

A4M05604 29GA STEEL SHEETING (x1)

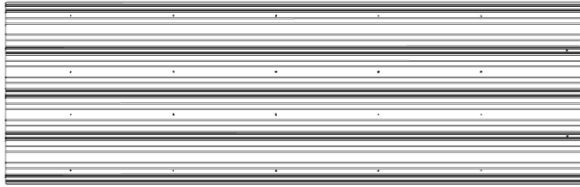

A4M04160 29GA STEEL SHEETING (x1)

QTY	PART NUMBER	DESCRIPTION
50	H101117	SCREW WOODGRIP 10-16x3/4" BLK

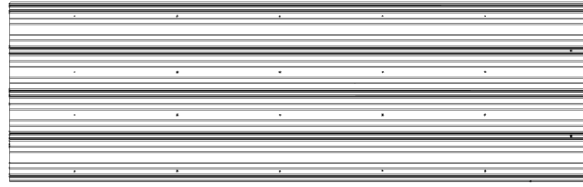

A4M04903 29GA STEEL SHEETING (x1)

- MAKE SURE ROOF PANEL IS SQUARE BEFORE MOVING ON.

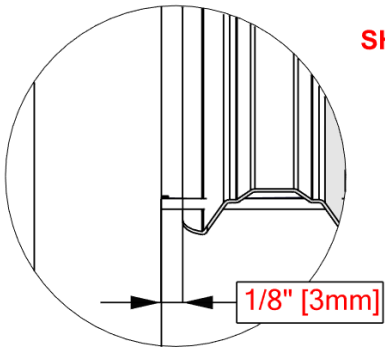
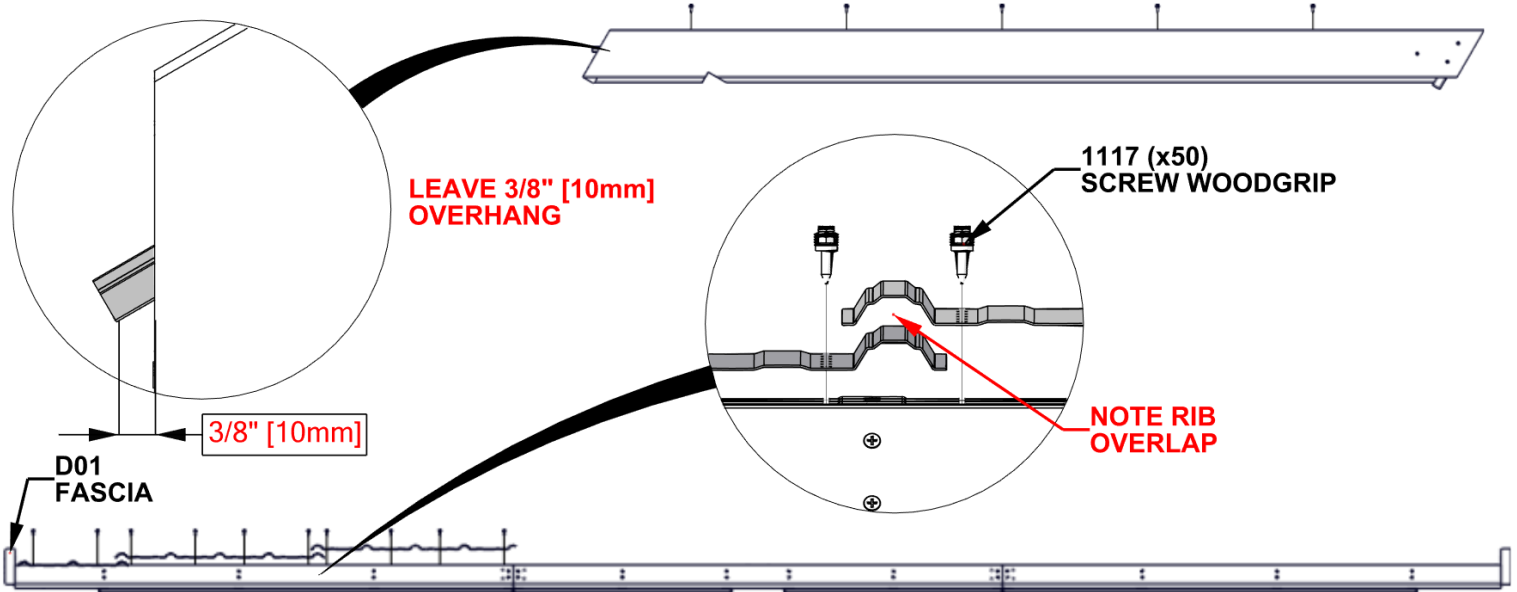

SHEETING SHOULD MEASURE 1/8" [3mm] FROM THE EDGE TO THE D01 BOARD AS SHOWN.

MEASUREMENT FROM D01 BOARD TO END OF 4903 PANEL IS: 73-7/16" [1865mm]

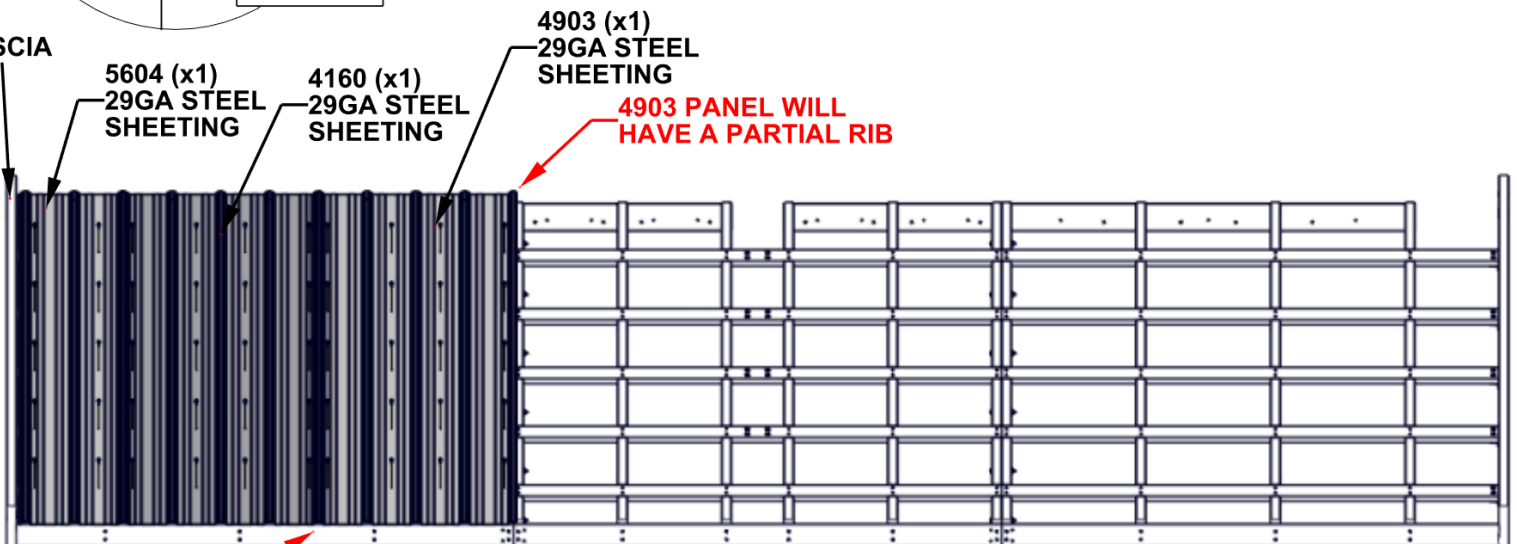

STEP 29 - ROOF PANEL 'A' ASSEMBLY

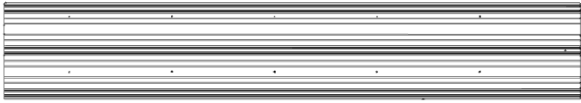

A4M05604 29GA STEEL SHEETING (x1)

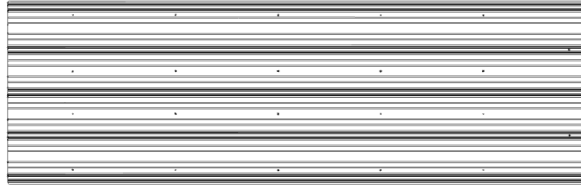

A4M04160 29GA STEEL SHEETING (x1)

QTY	PART NUMBER	DESCRIPTION
50	H101117	SCREW WOODGRIP 10-16x3/4" BLK

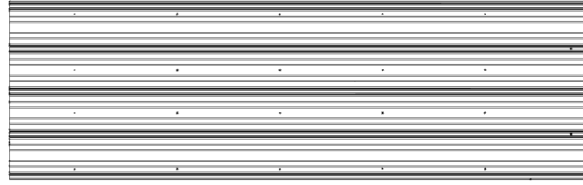

A4M04903 29GA STEEL SHEETING (x1)

- PANEL A4M04903 WILL HAVE A PARTIAL RIB AS SHOWN BELOW.

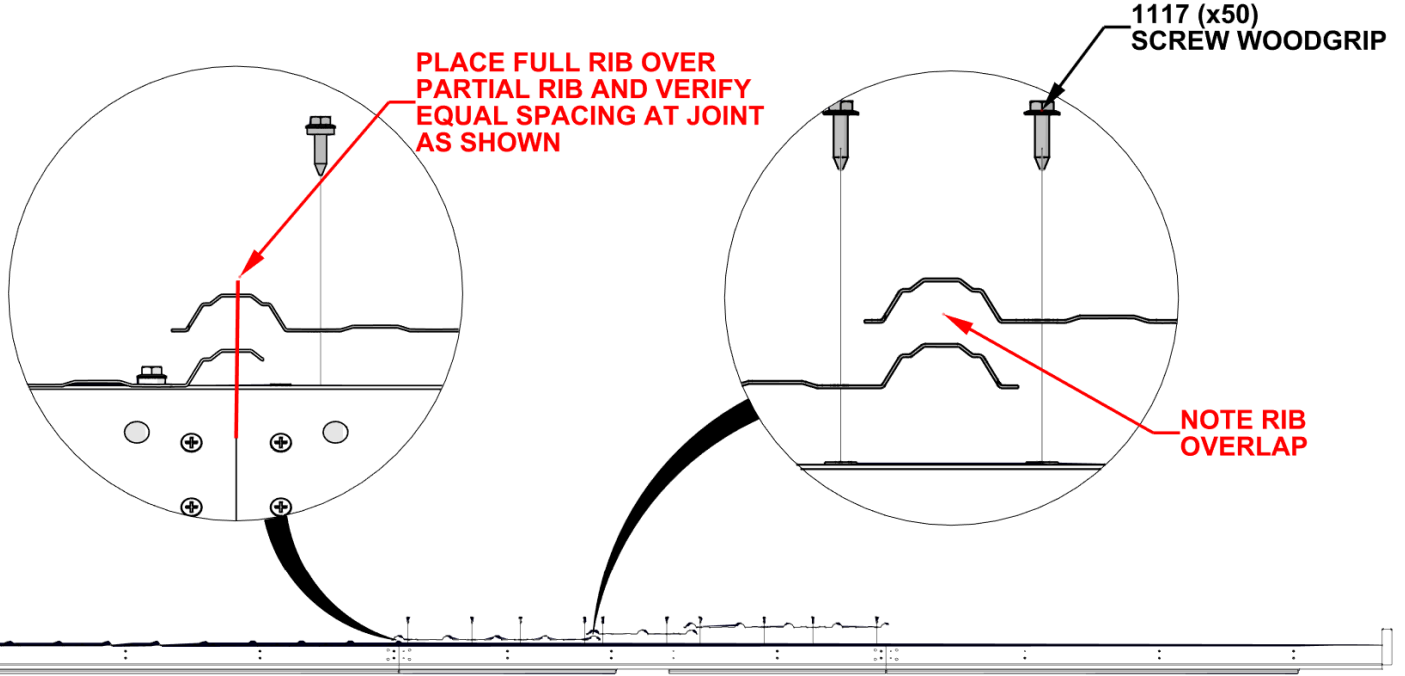

MEASUREMENT FROM D01 TO 4903 PANEL IS: 145-1/16" [3685mm]

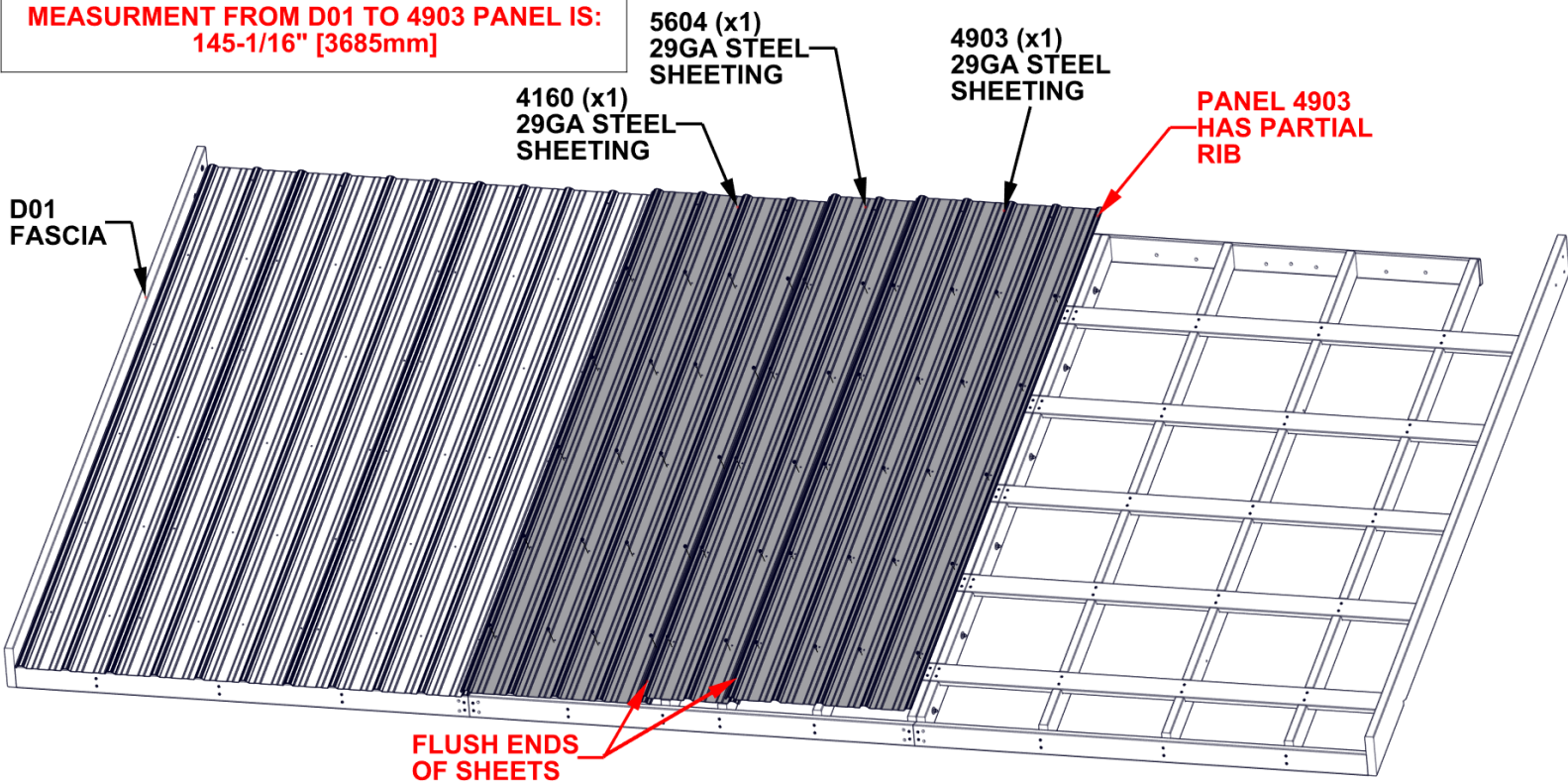

STEP 30 - ROOF PANEL 'A' ASSEMBLY

QTY	PART NUMBER	DESCRIPTION
50	H101117	SCREW WOODGRIP 10-16x3/4" BLK

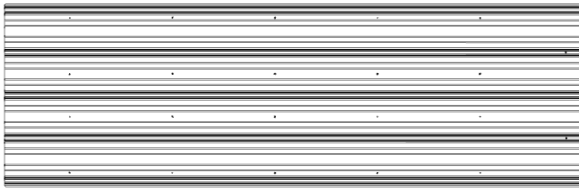

A4M04160 29GA STEEL SHEETING
(x2)

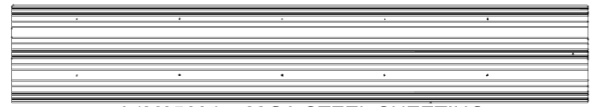

A4M05604 29GA STEEL SHEETING
(x1)

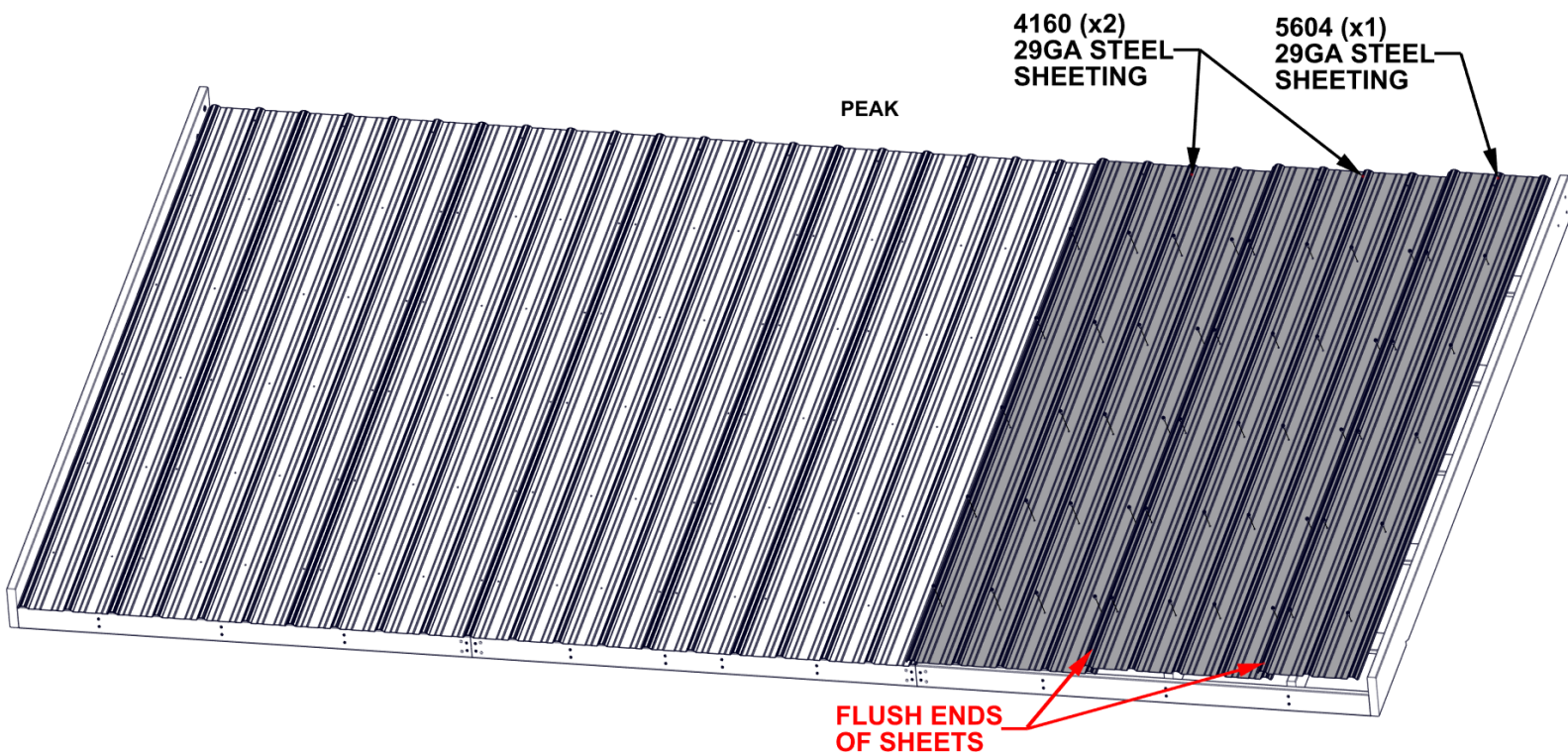
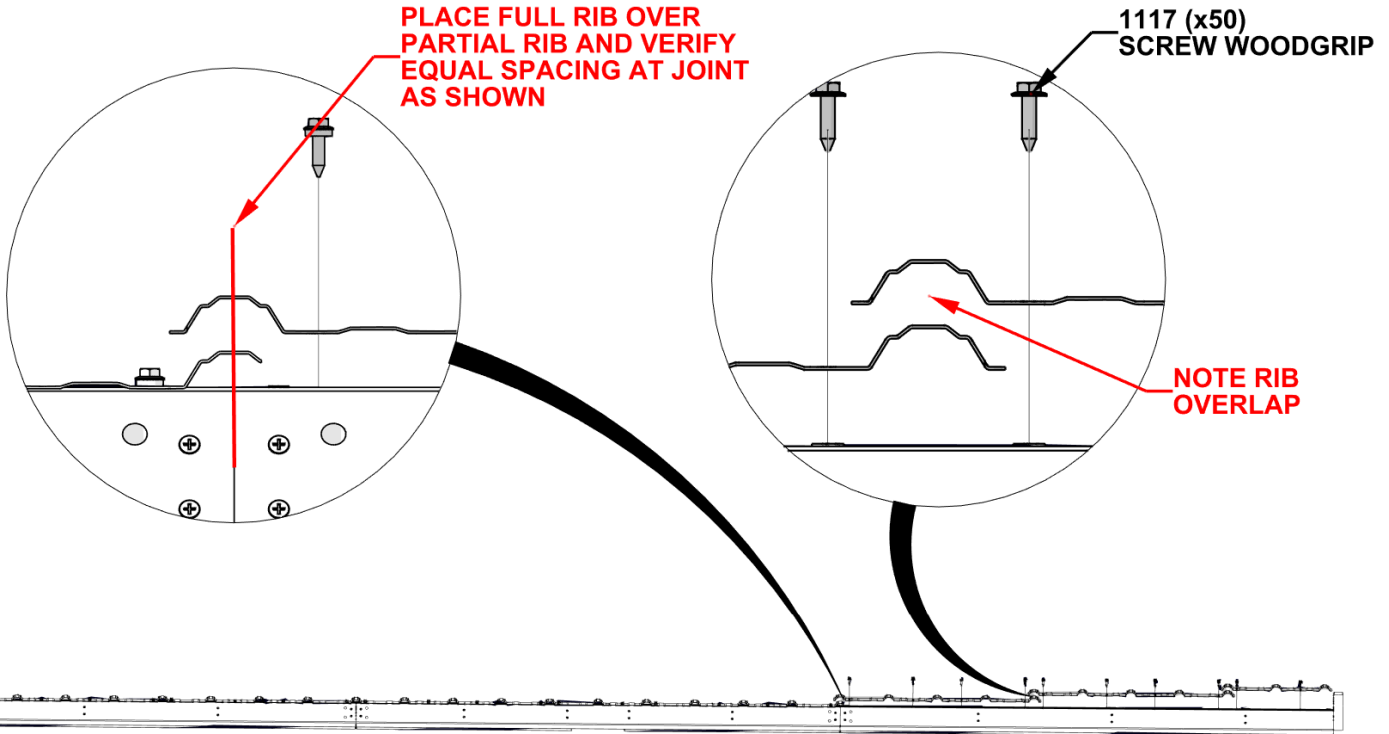

STEP 31 - ROOF PANEL 'A' ASSEMBLY

QTY	PART NUMBER	DESCRIPTION
10	H101116	SCREW SELF TAPPING 1/4x1 BLK

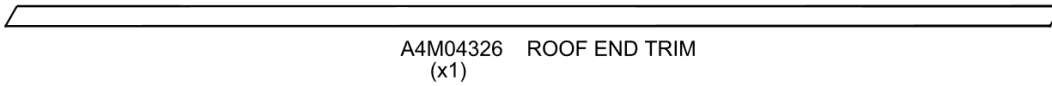
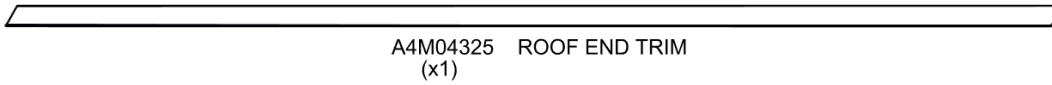

- REMOVE PROTECTIVE BLUE FILM.
- GLOVES SHOULD BE WORN WHEN HANDLING ROOF PANELS: EDGES ARE SHARP.
- ALIGN 1116 HARDWARE IN-LINE WITH HARDWARE FROM ROOF SHEETING.

1116 (x10)
SCREW - 1"

ALIGN HARDWARE WITH
SHEET METAL SCREWS IN
ROOF ASSEMBLY

FLUSH

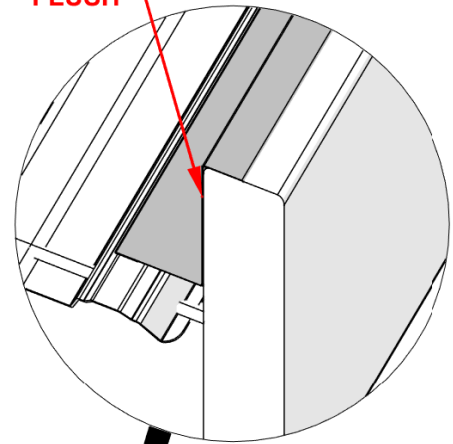
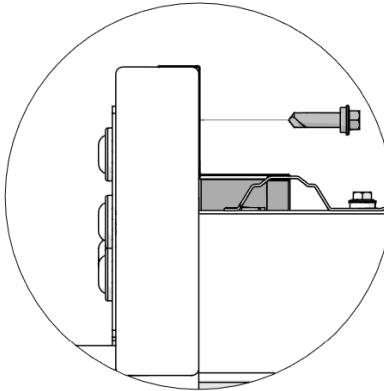
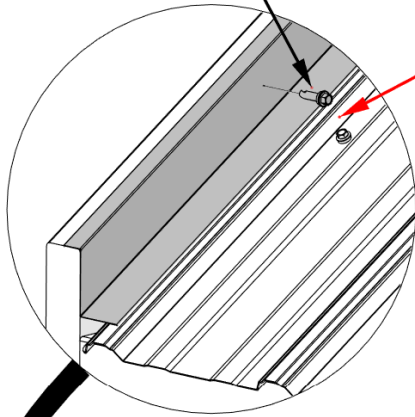

CENTER HARDWARE ALONG
ROOF END TRIM AS SHOWN

4325 (x1)
ROOF END TRIM

PEAK

4326 (x1)
ROOF END TRIM

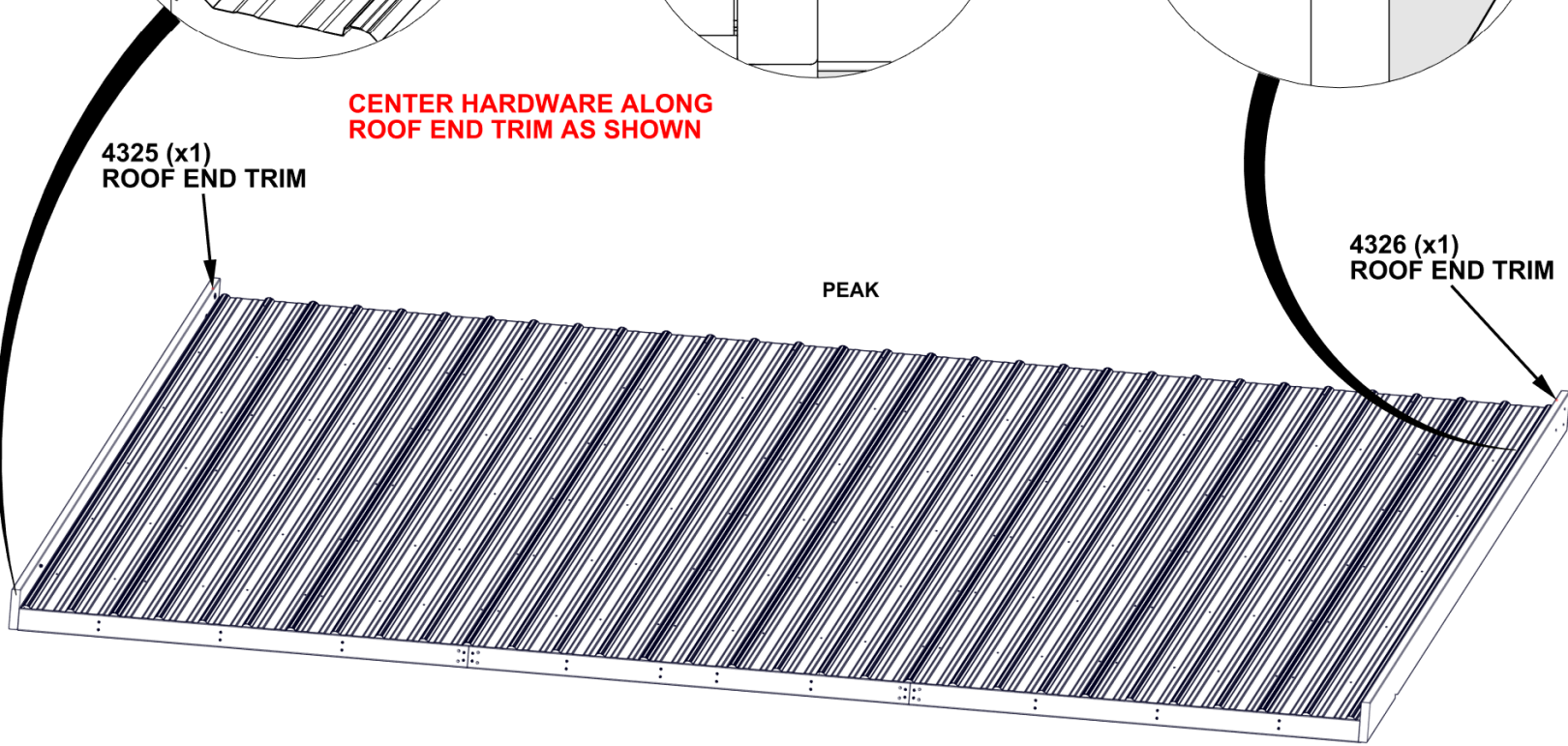

STEP 32 - ROOF PANEL 'A' ASSEMBLY

- SEPERATE ROOF PANEL FOR EASE OF ASSEMBLY.
- REMOVE HARDWARE AND SET ASIDE. IT WILL BE USED AGAIN AFTER BOTH SECTIONS ARE INSTALLED.

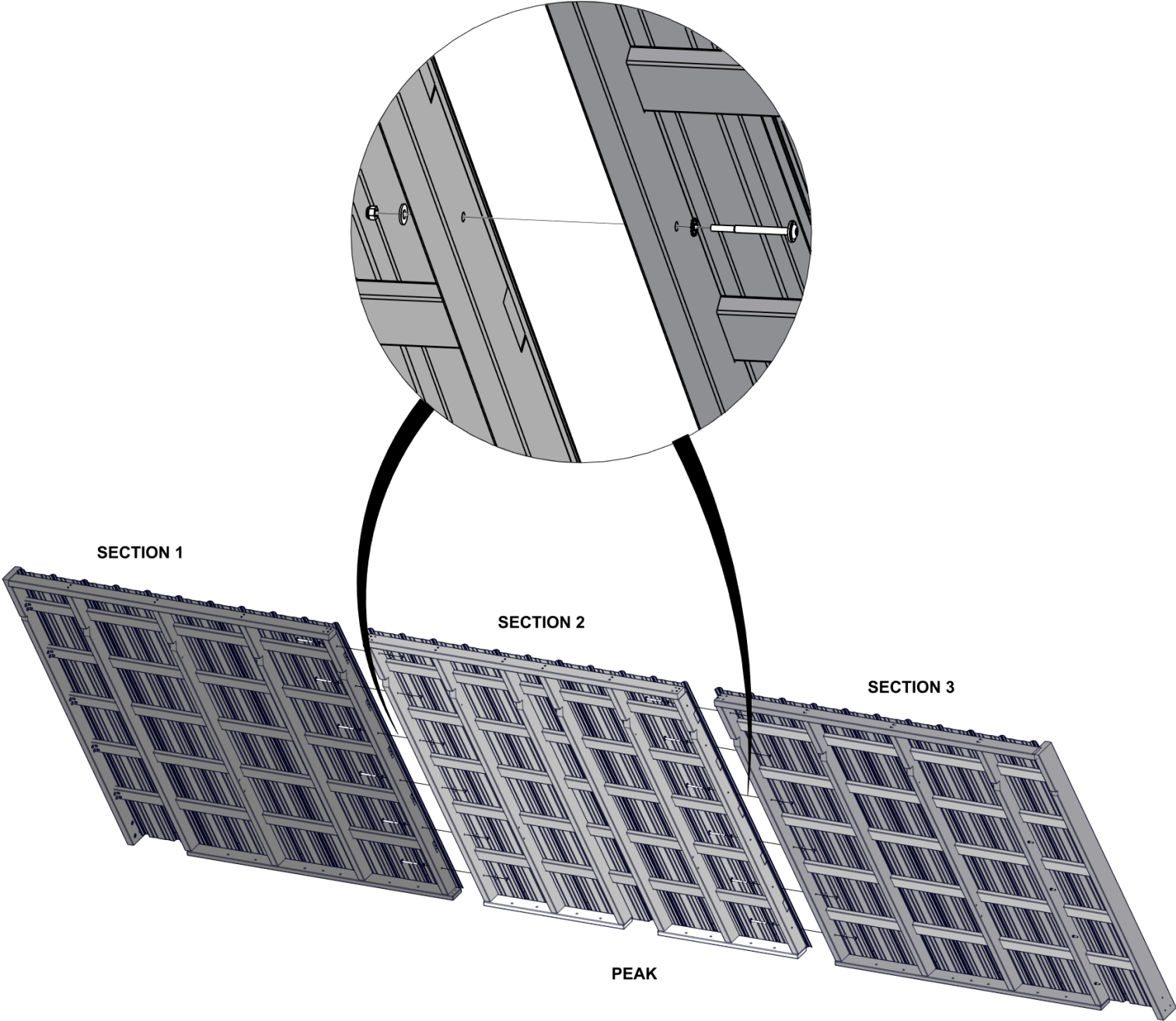

STEP 33A - ROOF PANEL 'B' ASSEMBLY

E04	RAFTER - W4L21176
(x1)	1 7/16"x3 3/8"x95 1/16" (36x86x2414)
E02	RAFTER - W4L21178
(x1)	1 7/16"x3 3/8"x95 1/16" (36x86x2414)
E07	RAFTER - W4L21561
(x2)	1 7/16"x3 3/8"x95 1/16" (36x86x2414)
E05	TRIM BOARD - W4L21849
(x1)	1 7/16"x3 3/8"x73" (36x86x1854)

QTY	PART NUMBER	DESCRIPTION
8	H100201	SCREW PFH 8x2 1/2 BLK
2	H100379	T-NUT 5/16 BLK
8	H100391	SCREW PFH 8x2 BLK

AD08	RIDGE SUPPORT - W4L21850
(x1)	15/16"x4"x60 11/16" (24x102x1541)

- INSERT T-NUTS FIRST, FAILURE TO DO SO WILL RESULT IN INCORRECT ASSEMBLY.

- ALIGN AD08 AND E05 WITH PILOT HOLES IN RAFTER BOARDS.
- NOTE ORIENTATION OF AD08 BOARD, HOLES ARE TOWARD THE BOTTOM OF BOARD.
- TO HELP WITH ORGANIZATION, WE SUGGEST LABELING 'S1B' ON THE SCREW SIDE OF AD08 RIDGE SUPPORT TO KEEP TRACK OF SECTION 1, PANEL B.

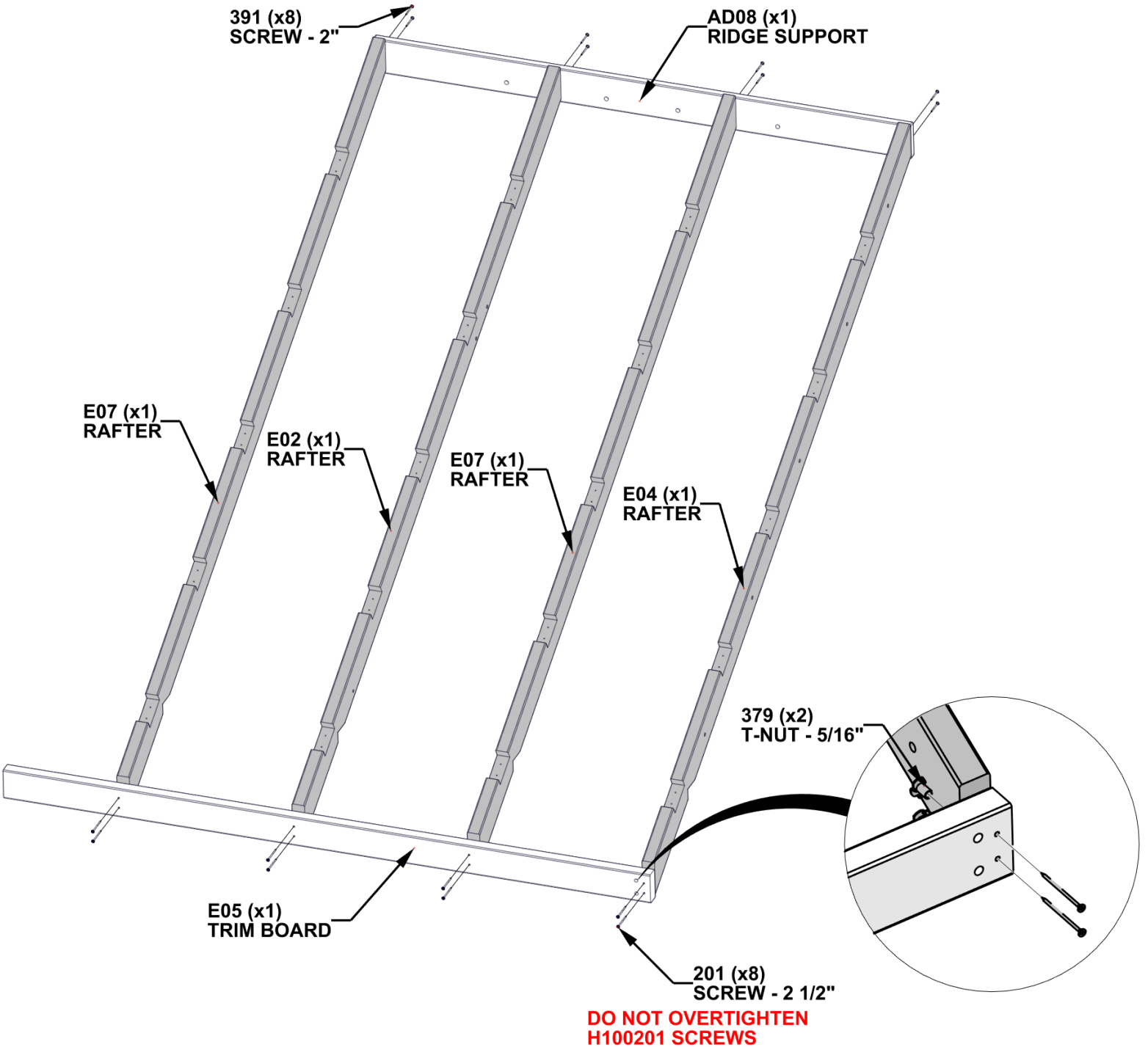

STEP 33B - ROOF PANEL 'B' ASSEMBLY

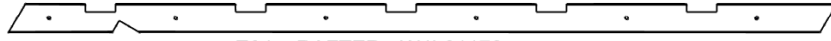

E04 RAFTER - W4L21176
(x2) 1 7/16"x3 3/8"x95 1/16" (36x86x2414)

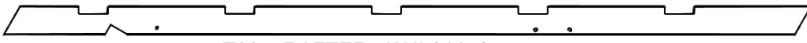

E02 RAFTER - W4L21178
(x2) 1 7/16"x3 3/8"x95 1/16" (36x86x2414)

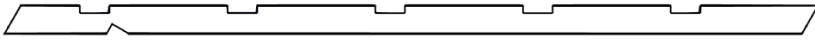

E07 RAFTER - W4L21561
(x2) 1 7/16"x3 3/8"x95 1/16" (36x86x2414)



E06 TRIM BOARD - W4L22012
(x1) 1 9/16"x3 3/8"x71 5/8" (36x86x1820)

QTY	PART NUMBER	DESCRIPTION
12	H100201	SCREW PFH 8x2 1/2 BLK
4	H100379	T-NUT 5/16 BLK
12	H100391	SCREW PFH 8x2 BLK



AD06 RIDGE SUPPORT - W4L22011
(x2) 15/16"x4"x31 15/16" (24x102x812)

- **INSERT T-NUTS FIRST. FAILURE TO DO SO WILL RESULT IN INCORRECT ASSEMBLY.**
- ALIGN AD06 AND E06 WITH PILOT HOLES IN RAFTER BOARDS.
- NOTE ORIENTATION OF AD06 BOARD, HOLES ARE TOWARD THE BOTTOM OF BOARD.
- TO HELP WITH ORGANIZATION, WE SUGGEST LABELING 'S2B' ON THE SCREW SIDE OF AD06 PEAK SUPPORT TO KEEP TRACK OF SECTION 2, PANEL B.

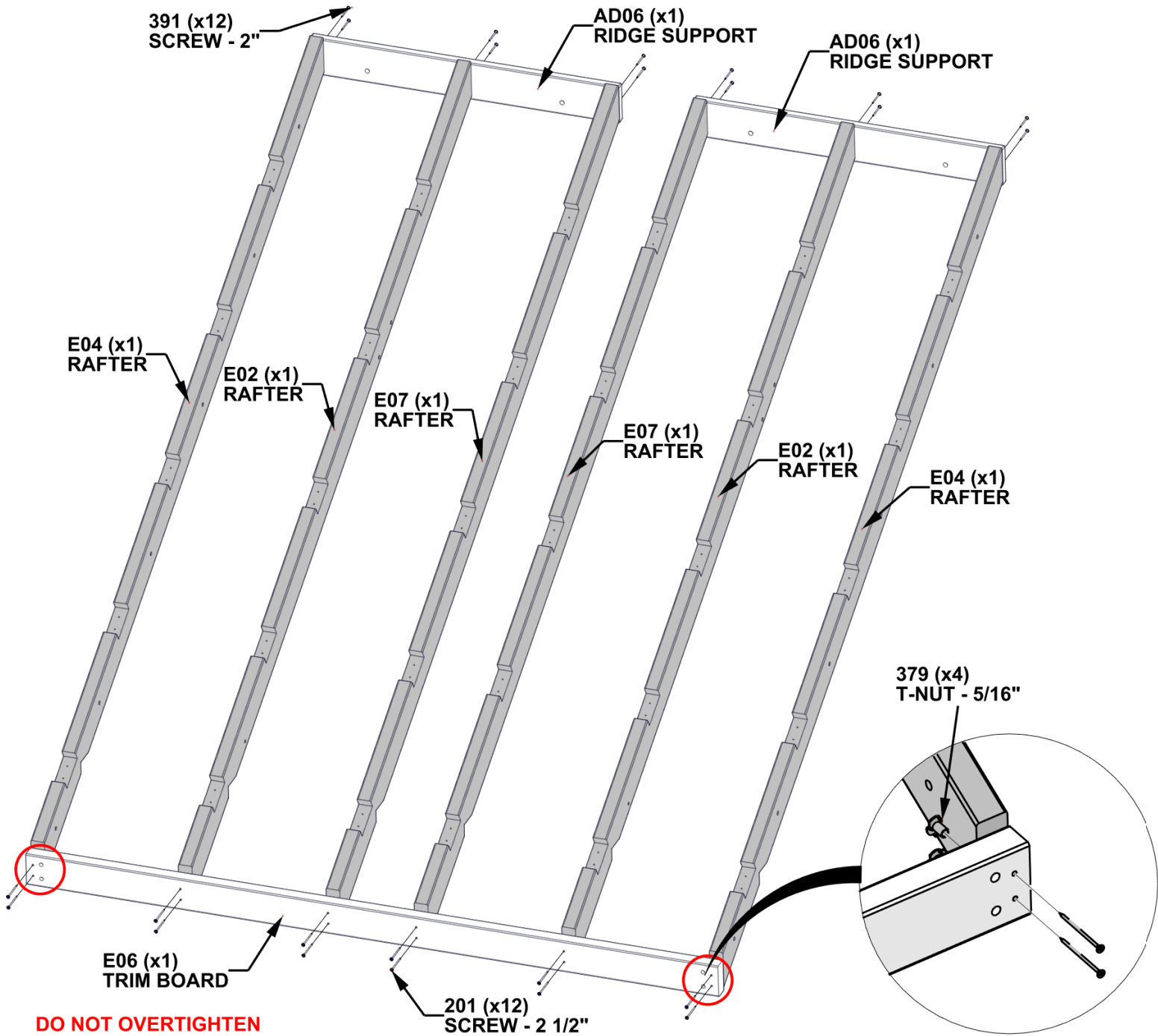

**DO NOT OVERTIGHTEN
H100201 SCREWS**

STEP 33C - ROOF PANEL 'B' ASSEMBLY

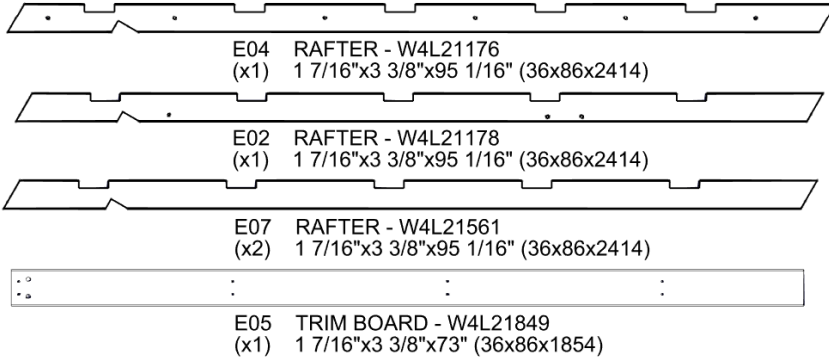

QTY	PART NUMBER	DESCRIPTION
8	H100201	SCREW PFH 8x2 1/2 BLK
2	H100379	T-NUT 5/16 BLK
8	H100391	SCREW PFH 8x2 BLK

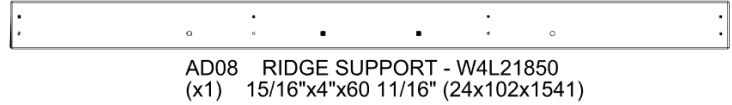

- INSERT T-NUTS FIRST. FAILURE TO DO SO WILL RESULT IN INCORRECT ASSEMBLY.

- ALIGN AD08 AND E05 WITH PILOT HOLES IN RAFTER BOARDS.
- NOTE ORIENTATION OF AD08 BOARD, HOLES ARE TOWARD THE BOTTOM OF BOARD.
- TO HELP WITH ORGANIZATION, WE SUGGEST LABELING 'S3B' ON THE SCREW SIDE OF AD08 RIDGE SUPPORT TO KEEP TRACK OF SECTION 3, PANEL B.

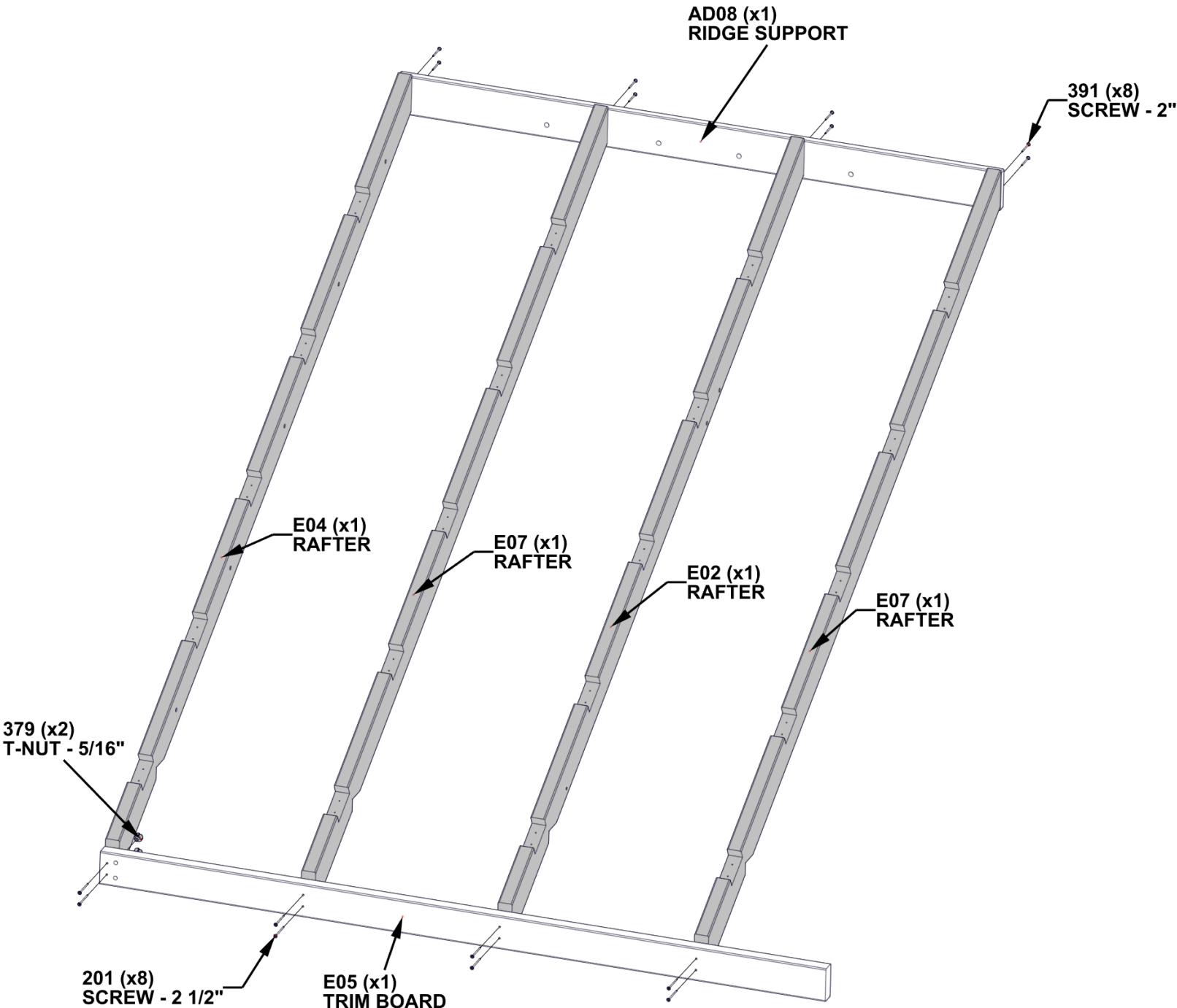

DO NOT OVERTIGHTEN H100201 SCREWS

STEP 33D - ROOF PANEL 'B' ASSEMBLY

QTY	PART NUMBER	DESCRIPTION
12	H100198	WASHER LOCK EXT 8x19
12	H100478	WASHER FLAT 8x27 BLK
12	H100479	NUT LOCK 5/16 BLK
12	H100503	BOLT WH 5/16x3 1/2 BLK

- ALIGN HOLES IN MIDDLE RAFTERS AND FASTEN HARDWARE AS SHOWN.

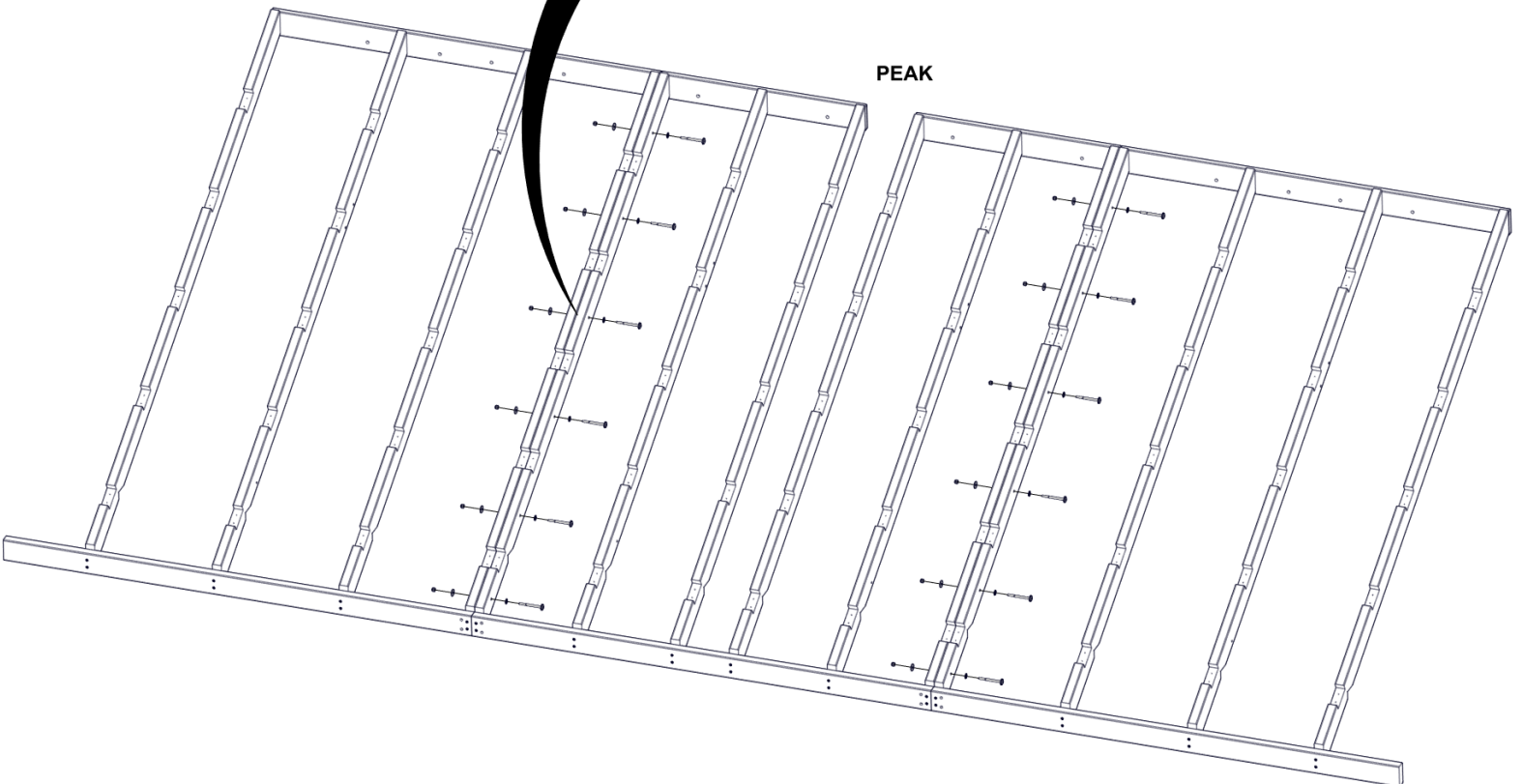
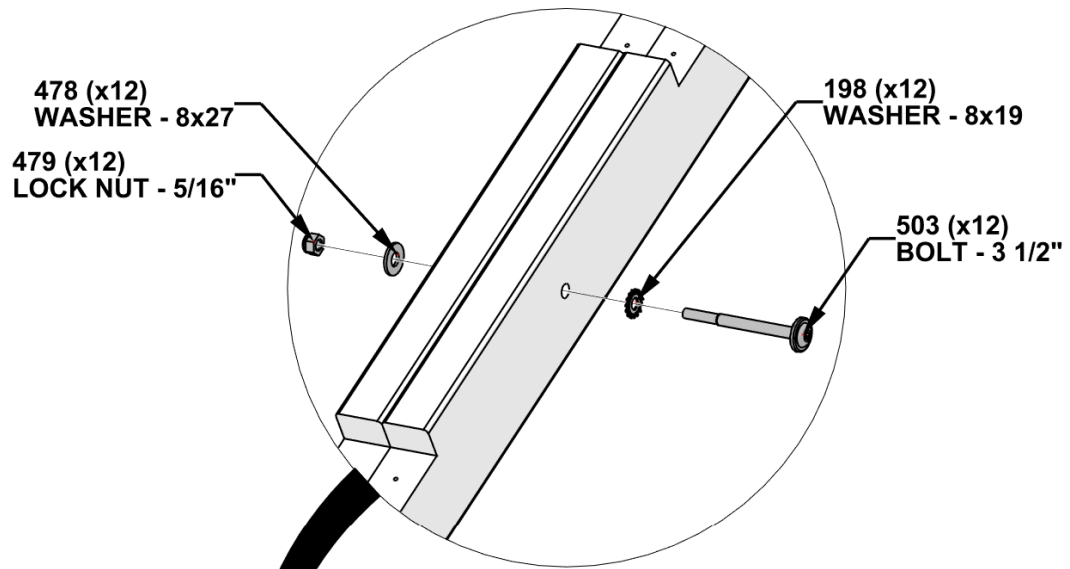

STEP 33E - ROOF PANEL 'B' ASSEMBLY

QTY	PART NUMBER	DESCRIPTION
20	H100171	BOLT WH 1/4x1 BLK
20	H100398	TNUT-1/4" BLK



H01 PURLIN - W4L21856
(x10) 15/16"x3 3/8"x72 15/16" (24x86x1852)

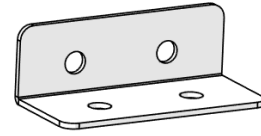

A4M04154 PURLIN SUPPORT BRACKET
(x10)

- INSERT T-NUTS FIRST.

- LONG SECTION OF 4154 BRACKET ATTACHES TO H01 PURLIN.
- COMPLETE THIS STEP 10 TIMES.

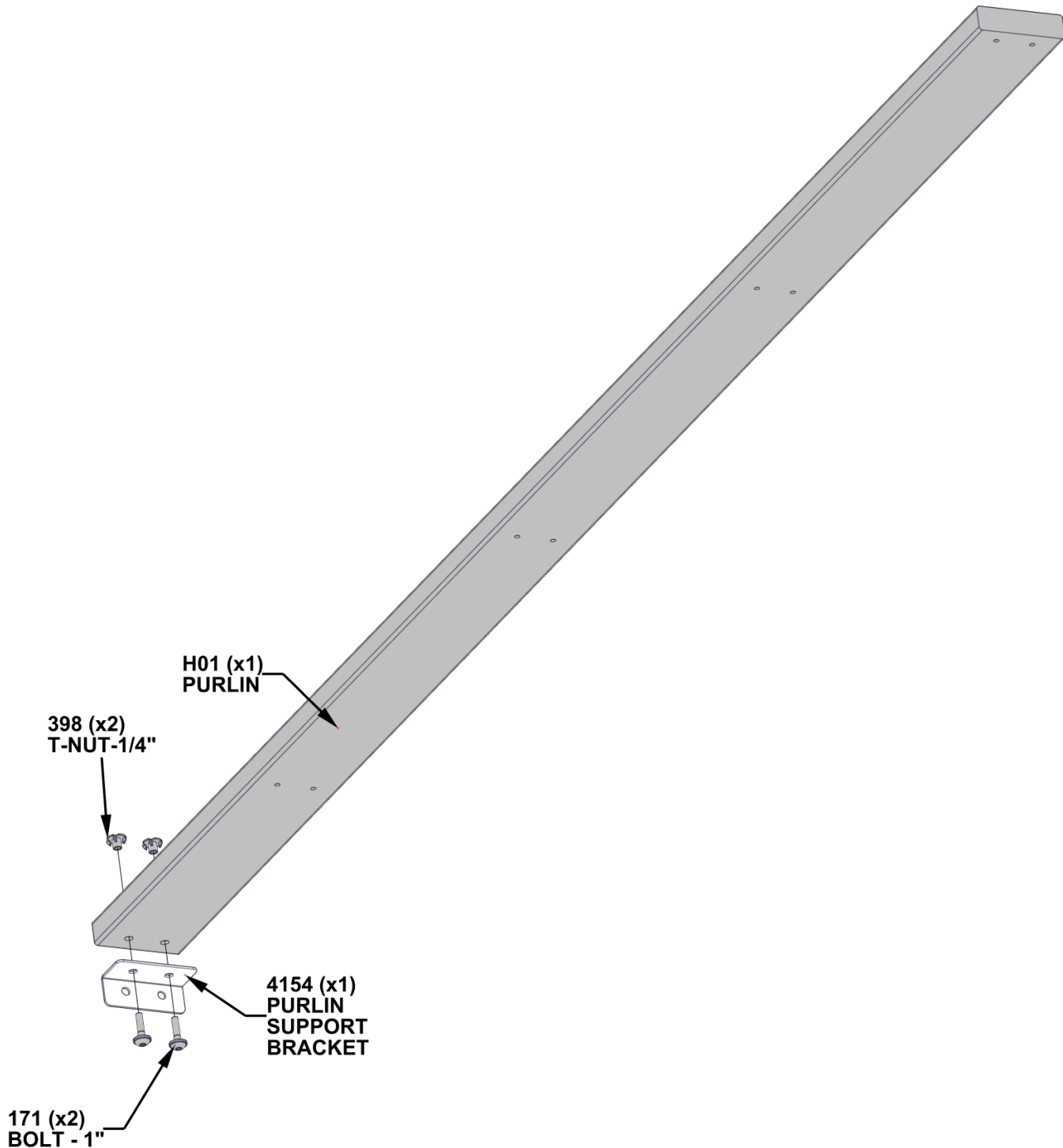

STEP 33F - ROOF PANEL 'B' ASSEMBLY

QTY	PART NUMBER	DESCRIPTION
140	H100391	SCREW PFH 8x2 BLK



H07 PURLIN - W4L22007
(x5) 15/16"x3 3/8"x71 9/16" (24x86x1818)

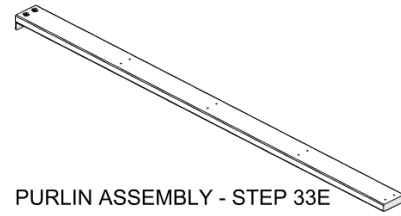

H01 PURLIN ASSEMBLY - STEP 33E
(x10)

- ALIGN PURLINS WITH PILOT HOLES IN RAFTERS.

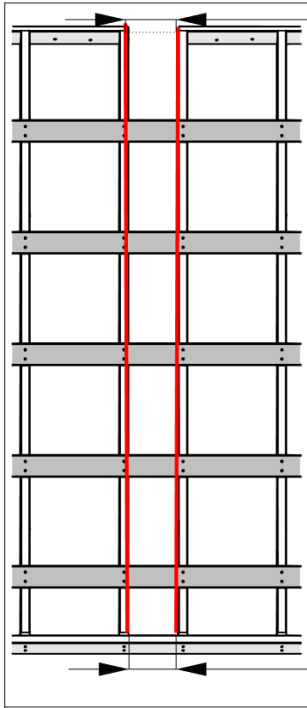

7-11/16" [196mm]

ENSURE THAT THE MIDDLE TWO RAFTRS ARE PARALLEL, THESE DIMENSIONS ARE CRITICAL. FAILURE TO FOLLOW WILL CAUSE ROOF TO BE OUT OF SQUARE AND REMAINING ASSEMBLY WILL NOT LINE UP.

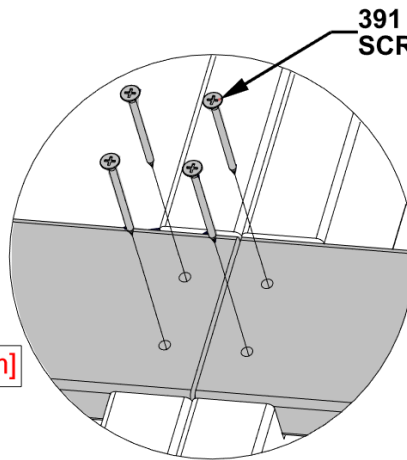

391 (x140)
SCREW - 2"

12-1/4" [312mm]

7-11/16" [196mm]

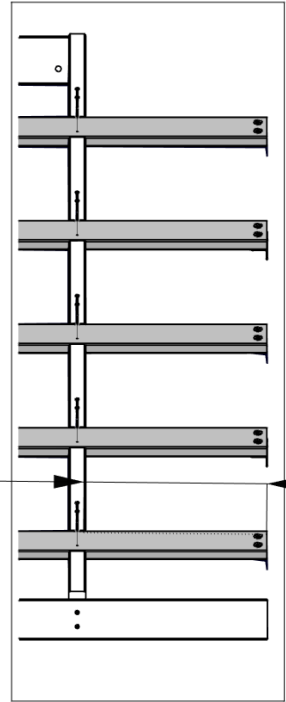

OVERHANG DISTANCE FOR PURLINS IS 12-1/4" [312mm] FROM END OF PURLIN TO RAFTER BOARD ON BOTH ENDS.

H01 (x5)
PURLIN
ASSEMBLY

PEAK

H07 (x5)
PURLIN

H01 (x5)
PURLIN
ASSEMBLY

STEP 33G - ROOF PANEL 'B' ASSEMBLY

QTY	PART NUMBER	DESCRIPTION
6	H100379	T-NUT 5/16 BLK
20	H100460	LAG SCREW WH 1/4x1 BLK

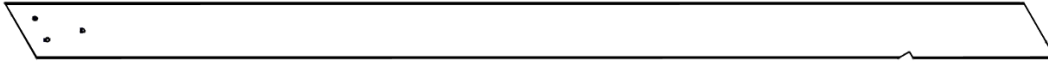

D01 FASCIA - W4L21164
(x1) 1 7/16"x5 1/4"x100" (36x134x2540)

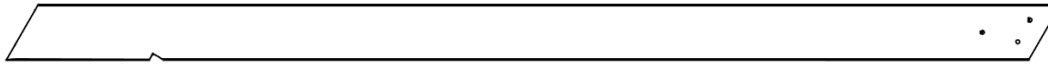

D02 FASCIA - W4L21175
(x1) 1 7/16"x5 1/4"x100" (36x134x2540)

- INSERT T-NUTS FIRST.

- ALIGN D01 AND D02 PILOT HOLES WITH HOLES IN 4154 BRACKETS ATTACHED IN PREVIOUS STEP.

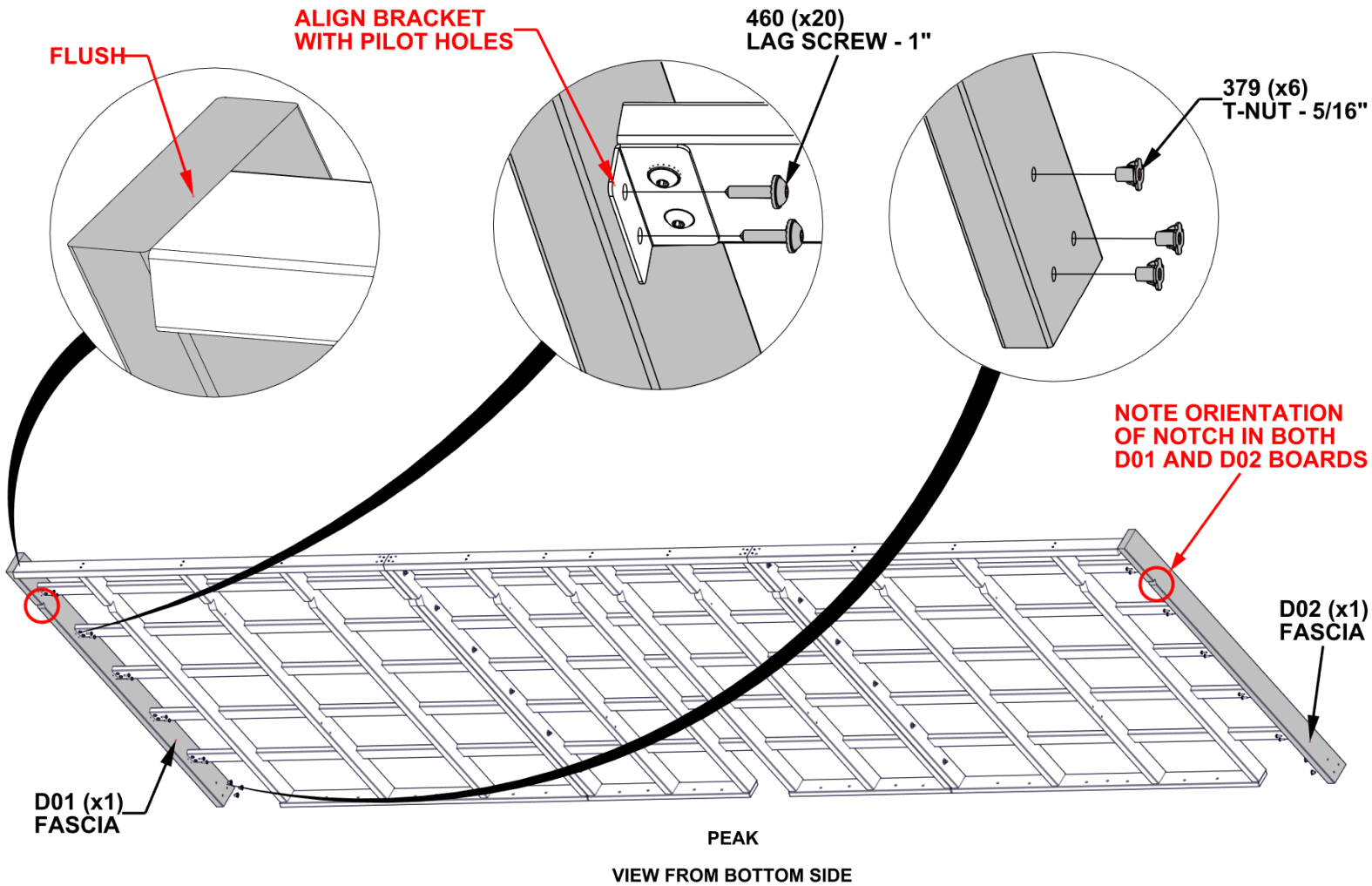

STEP 33H - ROOF PANEL 'B' ASSEMBLY

QTY	PART NUMBER	DESCRIPTION
8	H100797	SCREW PWH 8x1 BLK

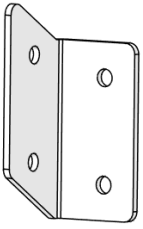

A4M04907 FASCIA BRACKET
(x1)

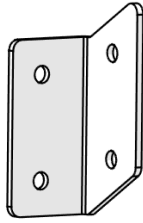

A4M04908 FASCIA BRACKET
(x1)

- ALIGN BRACKET 1/4" [6mm] FROM TOP OF TRIM BOARD AS SHOWN.

- ATTACH FASCIA BRACKET 4907 AND 4908 BY DRILLING A 1/8" [3mm] PILOT HOLE AND FASTENING WITH 797 SCREWS.

4907 (x1)
FASCIA BRACKET

**ALIGN BRACKET
1/4" [6mm] FROM
TOP OF BOARD**

797 (x8)
SCREW - 1"

**ALIGN BRACKET
1/4" [6mm] FROM
TOP OF BOARD**

4908 (x1)
FASCIA BRACKET

PEAK

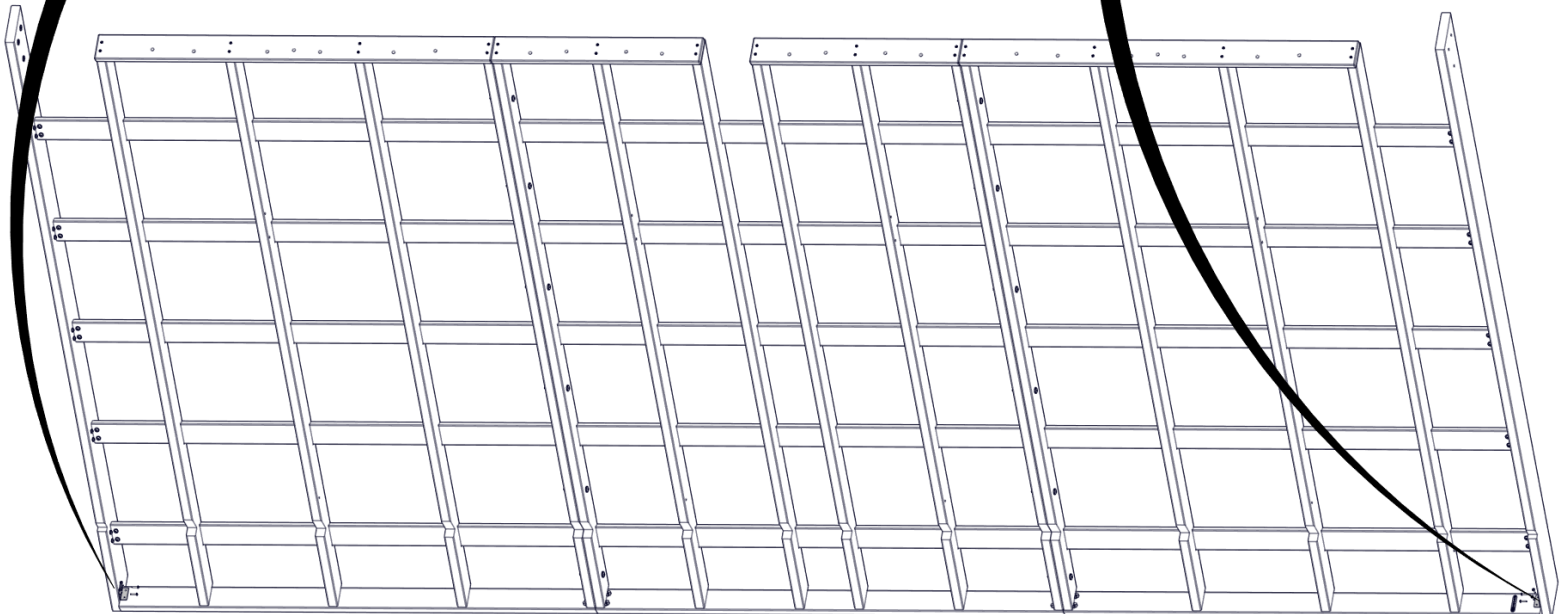

STEP 33I - ROOF PANEL 'B' ASSEMBLY

CRITICAL:

- SQUARE UNIT BEFORE PROCEEDING TO NEXT STEPS.
- THE BELOW DIMENSIONS ARE CRITICAL TO THE FINAL ROOF ASSEMBLY.
- MEASUREMENTS BELOW SHOULD BE HELD WITHIN +/- 1/4" [6mm].
- MEASUREMENTS OUTSIDE OF TOLERANCE WILL LEAD TO THE INABILITY TO ASSEMBLE THE ROOF.

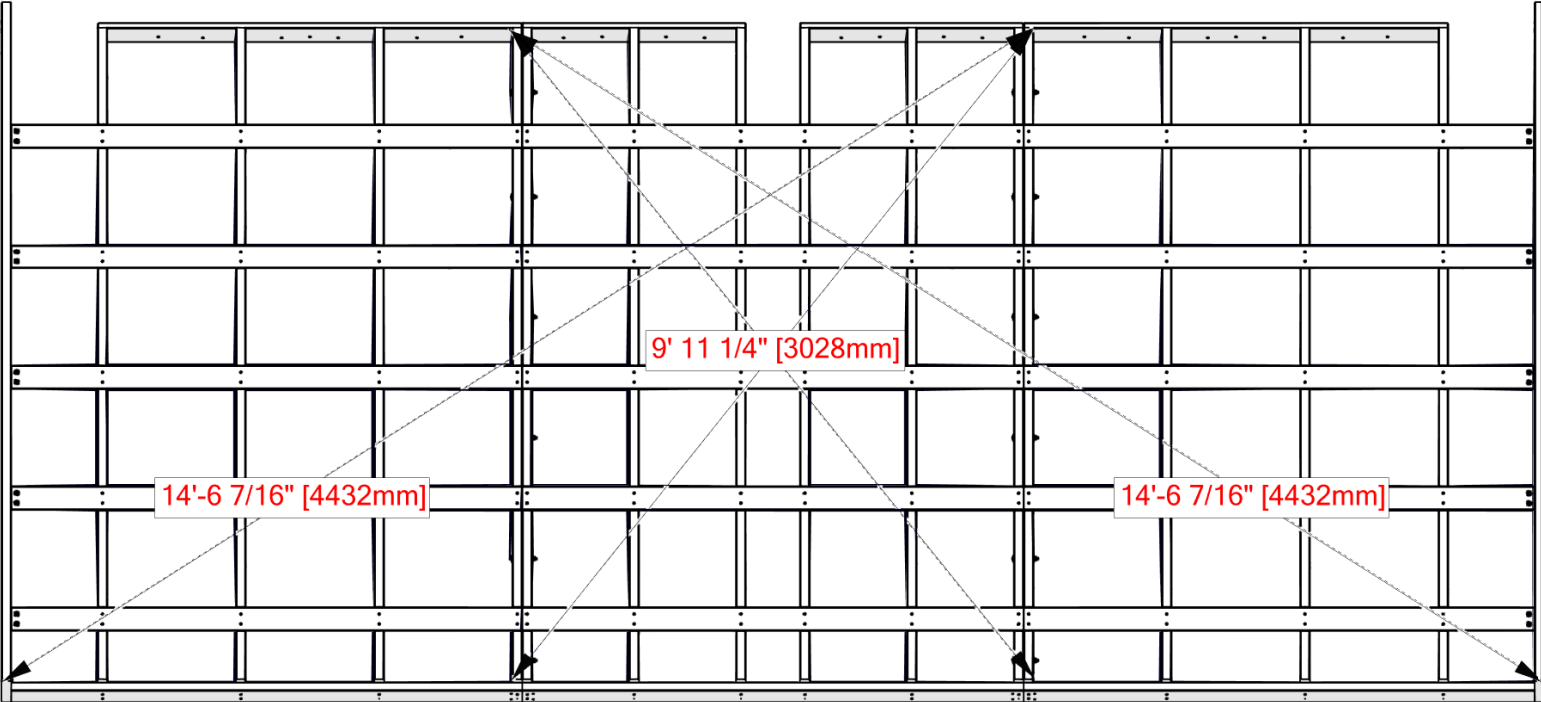

TIP: LOOSEN HARDWARE TO ADJUST FOR SQUARING IF NEEDED.

STEP 34 - ROOF PANEL 'B' ASSEMBLY

- USE THIS PAGE TO FAMILIARIZE YOURSELF WITH THE ROOF PANEL AND ASSIST YOU IN STEPS 34-38.
- REMOVE PROTECTIVE BLUE FILM.
- START AT THE END INDICATED AND ASSEMBLE IN THE DIRECTION OF THE ARROW.

- **GLOVES SHOULD BE WORN WHEN HANDLING ROOF PANELS: EDGES ARE SHARP.**
- **START BY PLACING FIRST SHEET 1/8" [3mm] FROM D02 FASCIA BOARD, THEN MARK WHERE EVERY OTHER SHEET WILL LAND AS SHOWN BELOW TO ENSURE THE PANELS WILL ALIGN CORRECTLY. THE LAST SHEET SHOULD ALIGN CLOSE TO THE EDGE OF D01 FASCIA BOARD.**

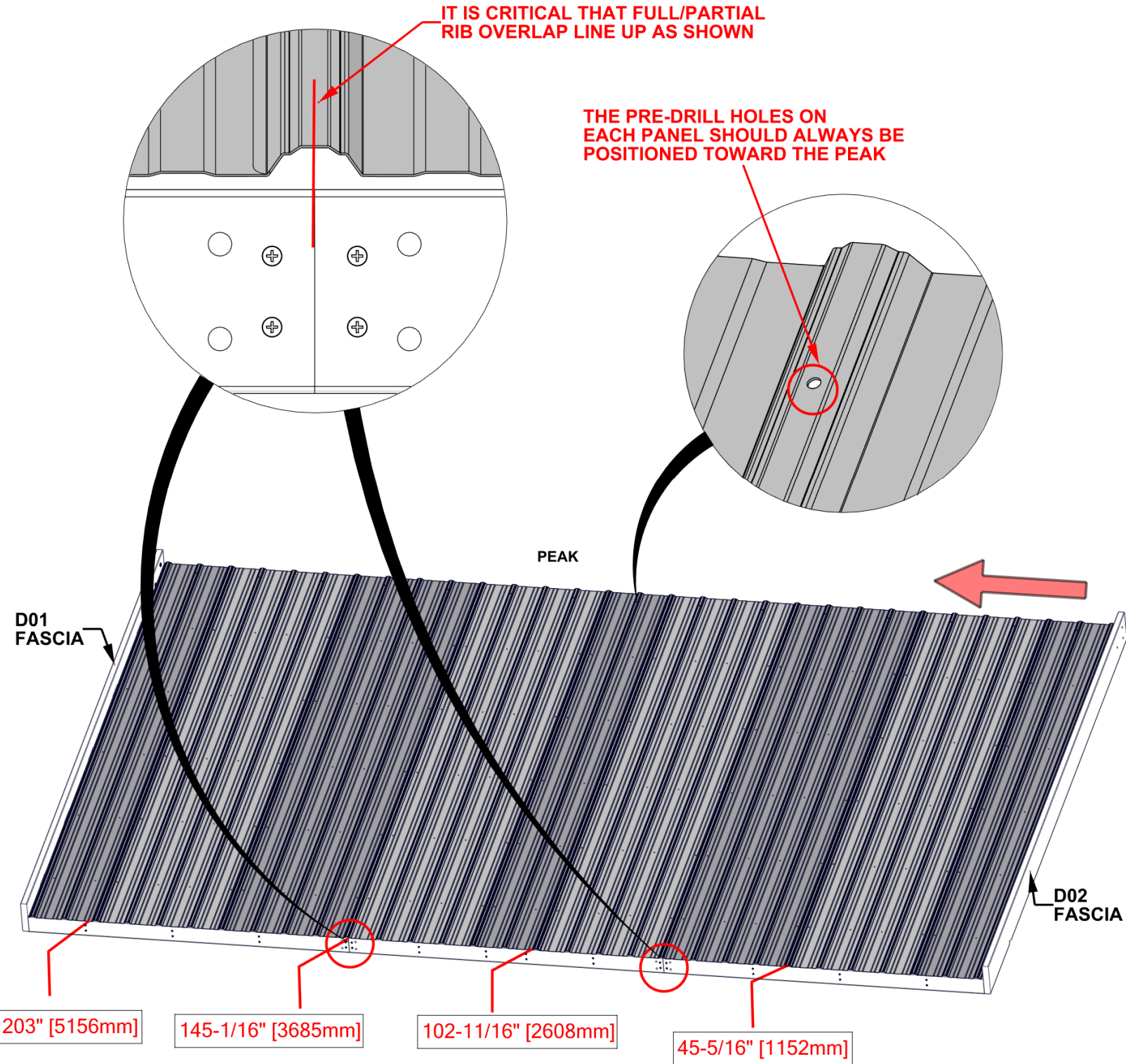

STEP 35 - ROOF PANEL 'B' ASSEMBLY

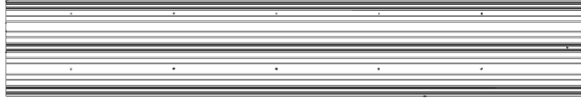

A4M05604 29GA STEEL SHEETING (x1)

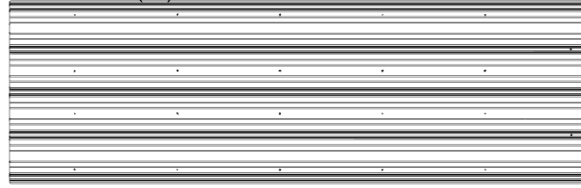

A4M04160 29GA STEEL SHEETING (x1)

QTY	PART NUMBER	DESCRIPTION
50	H101117	SCREW WOODGRIP 10-16x3/4" BLK



A4M05349 29GA STEEL SHEETING (x1)

- MAKE SURE ROOF PANEL IS SQUARE BEFORE MOVING ON.

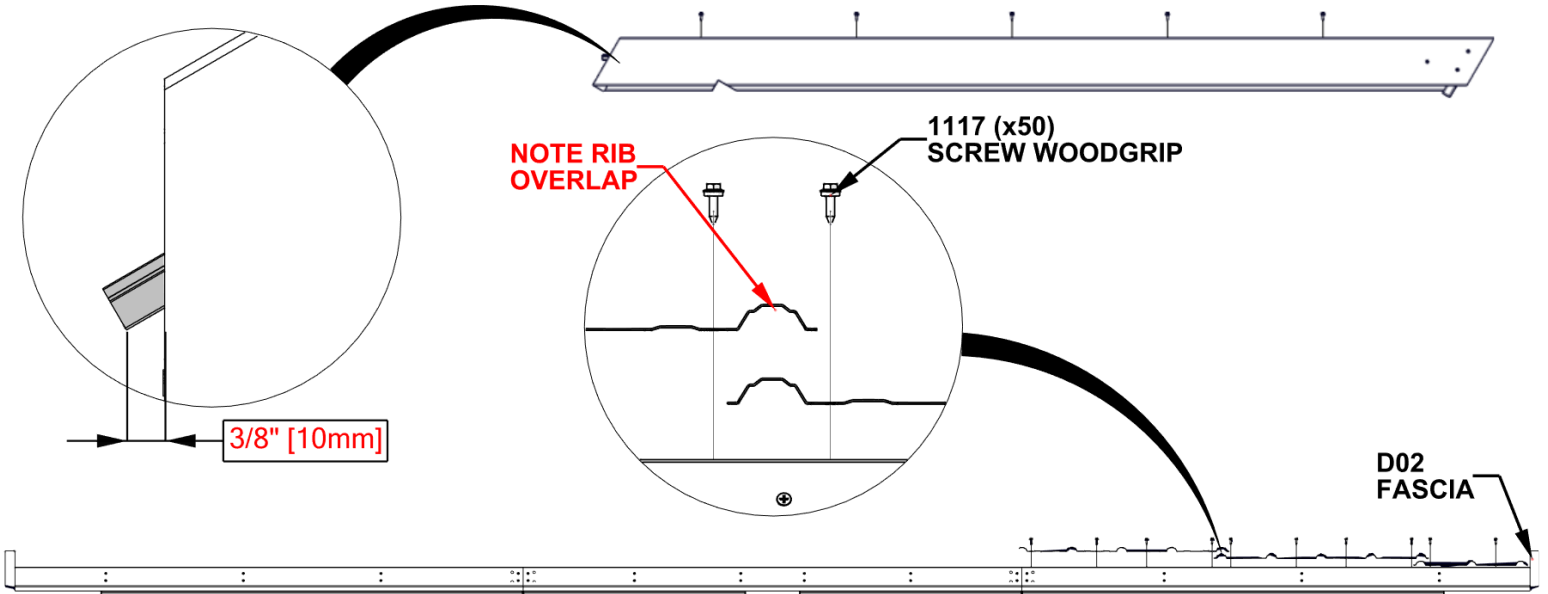

SHEETING SHOULD MEASURE 1/8" [3mm] FROM THE EDGE TO THE D02 BOARD AS SHOWN.

MEASUREMENT FROM D02 BOARD TO END OF 5349 PANEL IS: 73-7/16" [1865mm]

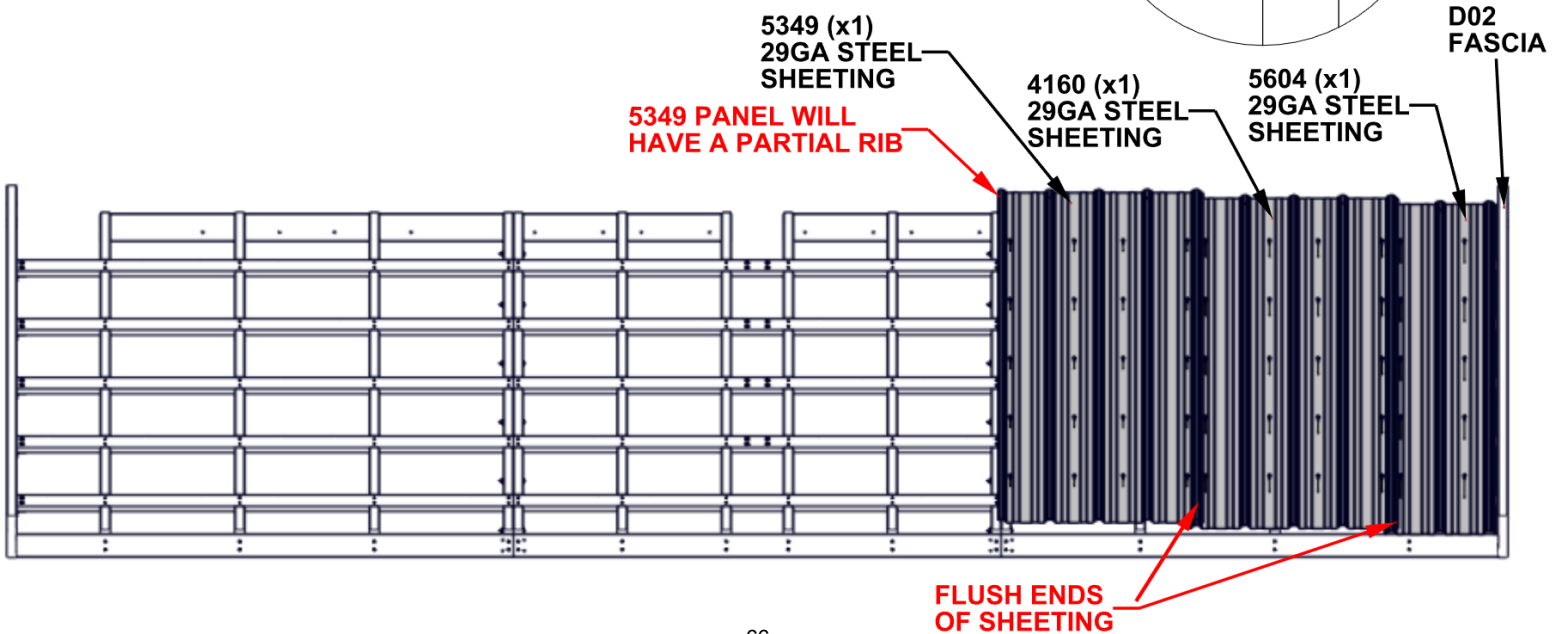
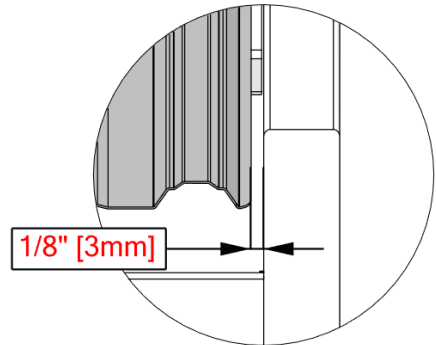

STEP 36 - ROOF PANEL 'B' ASSEMBLY



A4M05604 29GA STEEL SHEETING (x1)

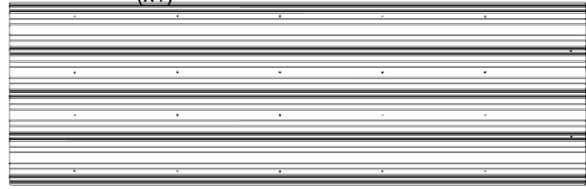

A4M04160 29GA STEEL SHEETING (x1)

QTY	PART NUMBER	DESCRIPTION
50	H101117	SCREW WOODGRIP 10-16x3/4" BLK



A4M05349 29GA STEEL SHEETING (x1)

- PANEL A4M05349 WILL HAVE A PARTIAL RIB AS SHOWN BELOW.

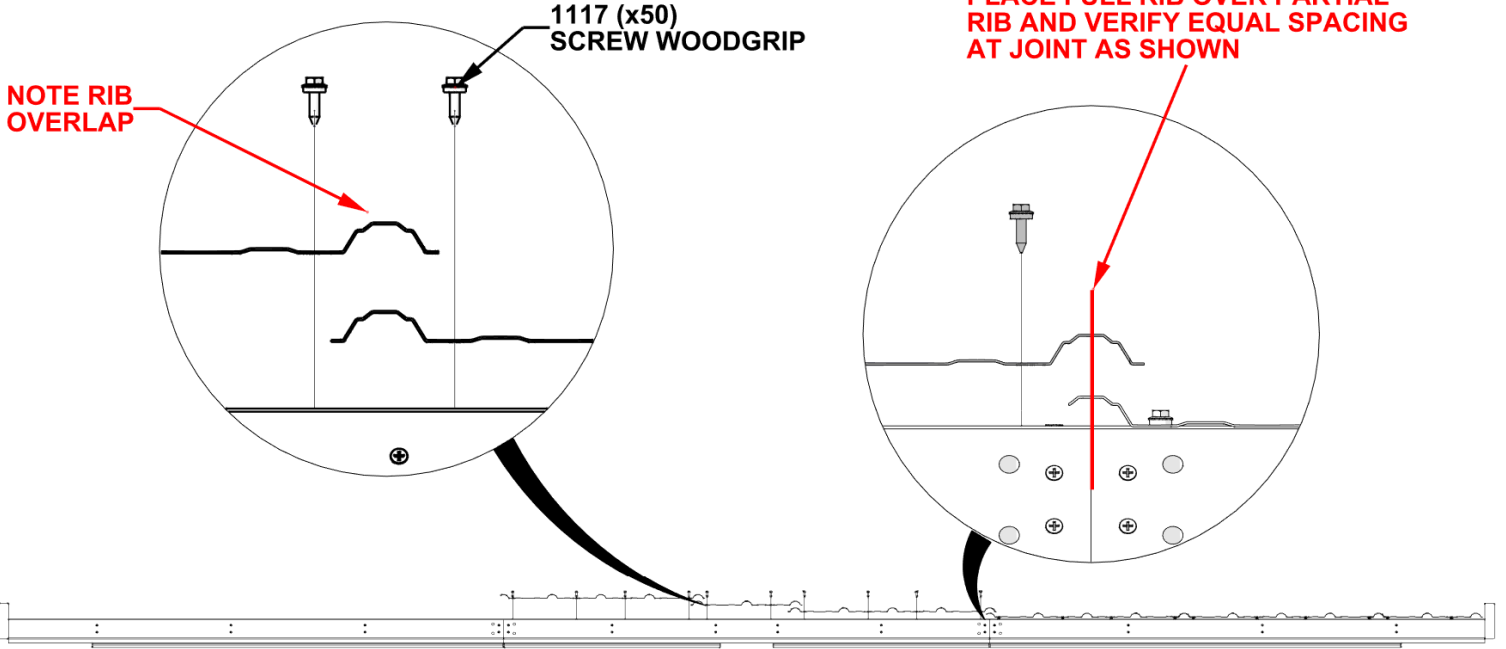

MEASUREMENT FROM D02 TO 5349 PANEL IS:
145-1/16" [3685mm]

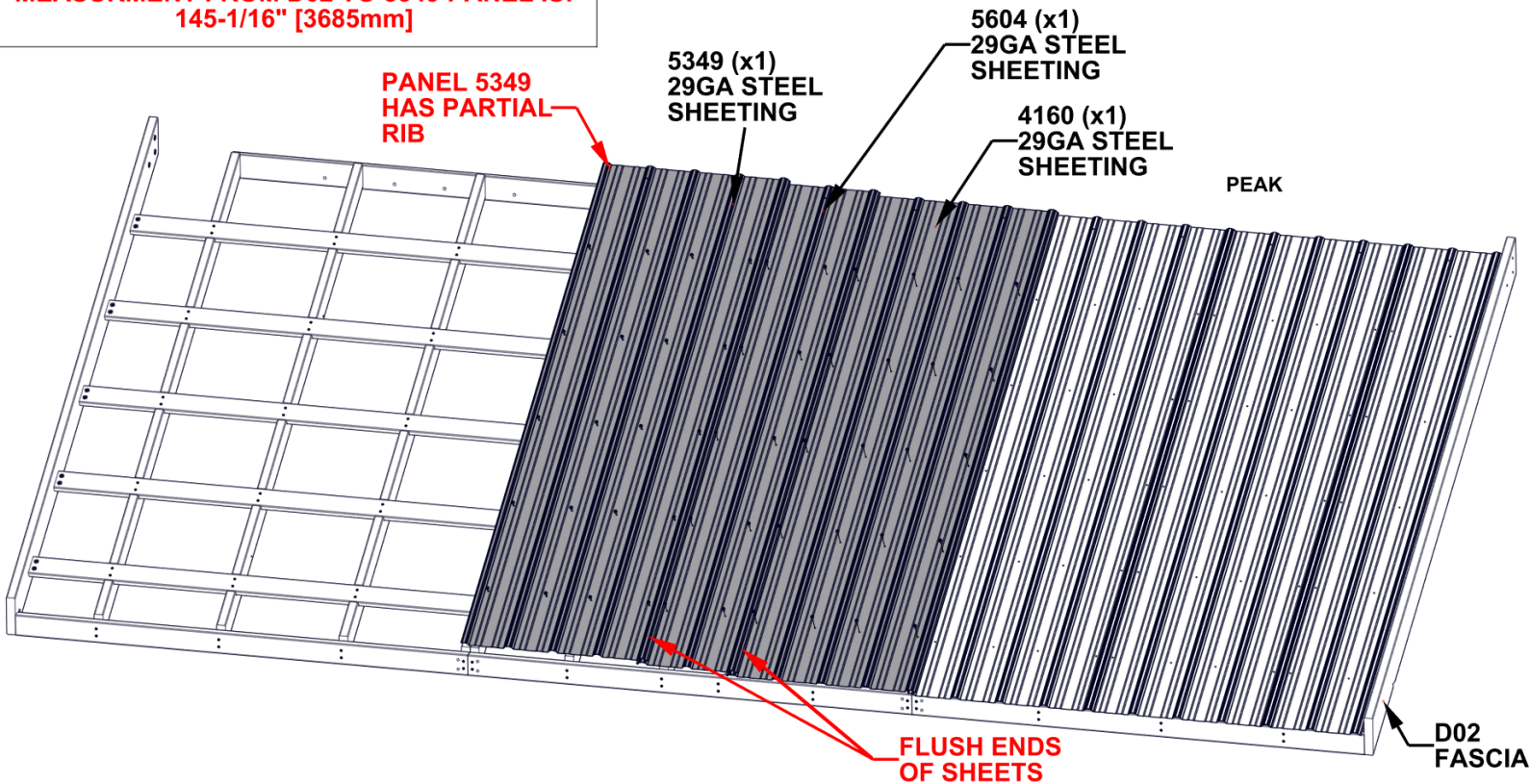

STEP 37 - ROOF PANEL 'B' ASSEMBLY

QTY	PART NUMBER	DESCRIPTION
50	H101117	SCREW WOODGRIP 10-16x3/4" BLK



A4M04160 29GA STEEL SHEETING
(x2)

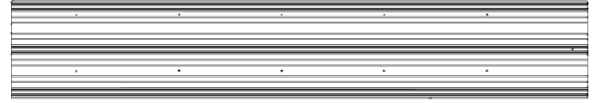

A4M05604 29GA STEEL SHEETING
(x1)

**PLACE FULL RIB OVER
PARTIAL RIB AND VERIFY
EQUAL SPACING AT JOINT
AS SHOWN**

1117 (x50)
SCREW WOODGRIP

**NOTE RIB
OVERLAP**

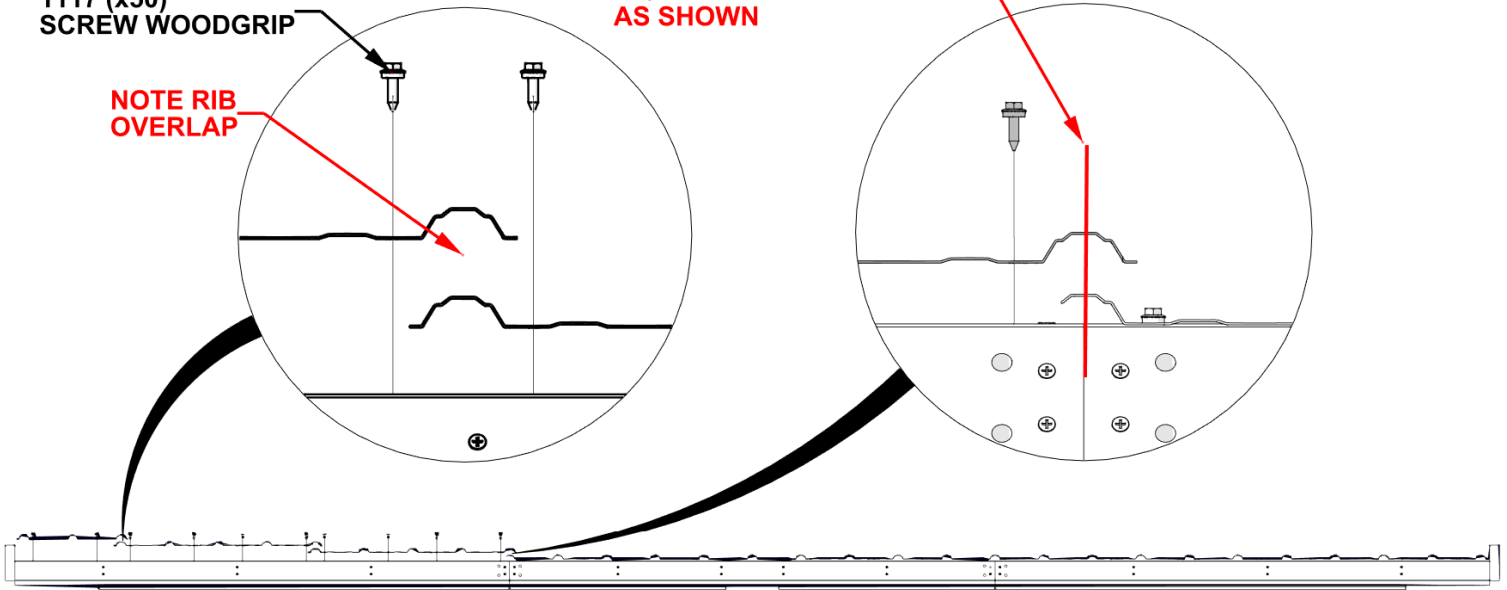

5604 (x1)
29GA STEEL
SHEETING

4160 (x2)
29GA STEEL
SHEETING

PEAK

**FLUSH ENDS
OF SHEETS**

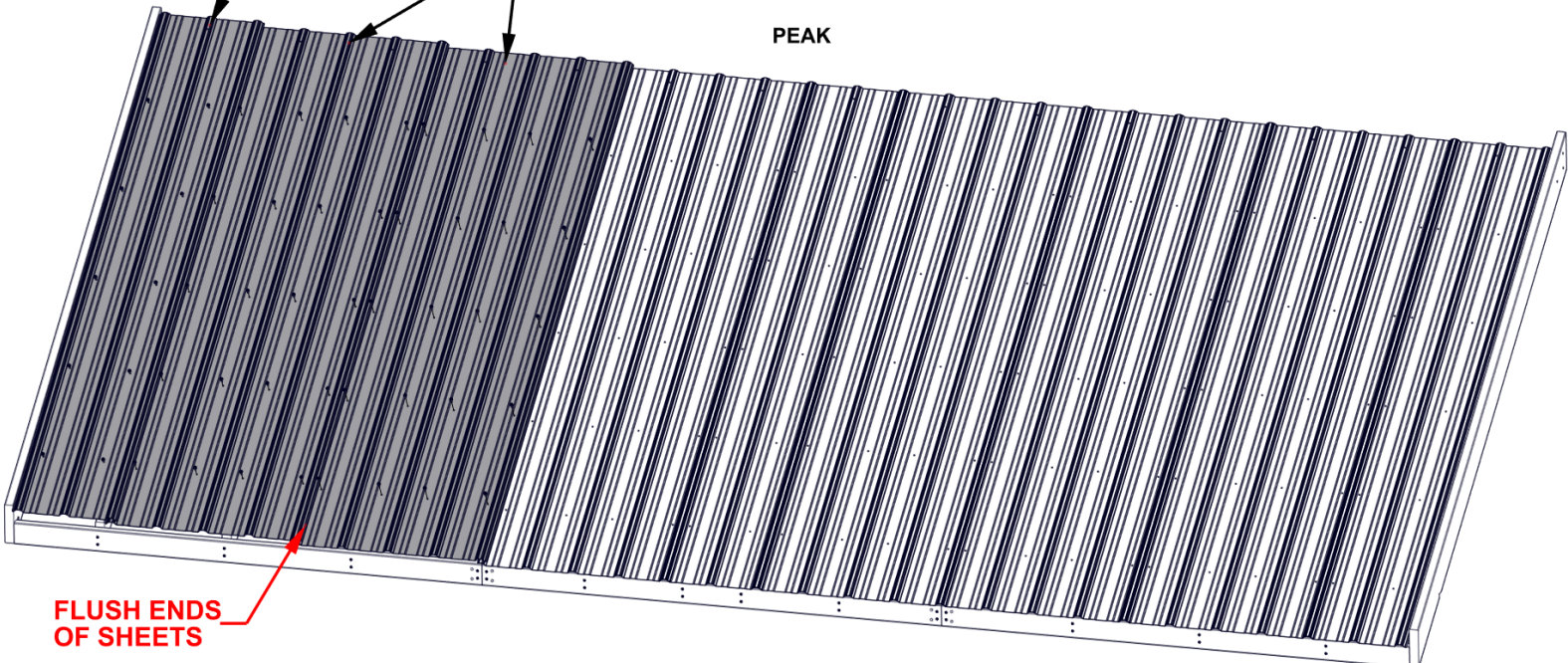

STEP 38 - ROOF PANEL 'B' ASSEMBLY

QTY	PART NUMBER	DESCRIPTION
10	H101116	SCREW SELF TAPPING 1/4x1 BLK

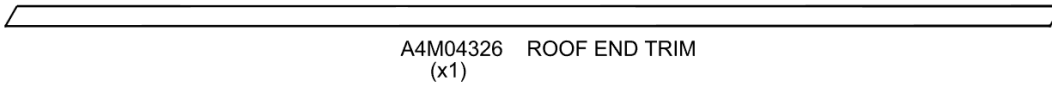
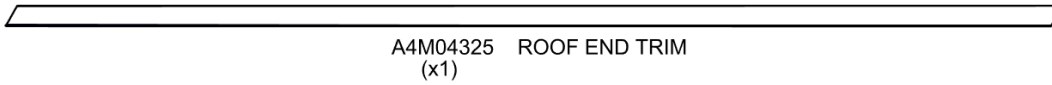

- REMOVE PROTECTIVE BLUE FILM.
- GLOVES SHOULD BE WORN WHEN HANDLING ROOF PANELS: EDGES ARE SHARP.
- ALIGN 1116 HARDWARE IN-LINE WITH HARDWARE FROM ROOF SHEETING.

1116 (x10) SCREW - 1" **ALIGN HARDWARE WITH SHEET METAL SCREWS IN ROOF ASSEMBLY**

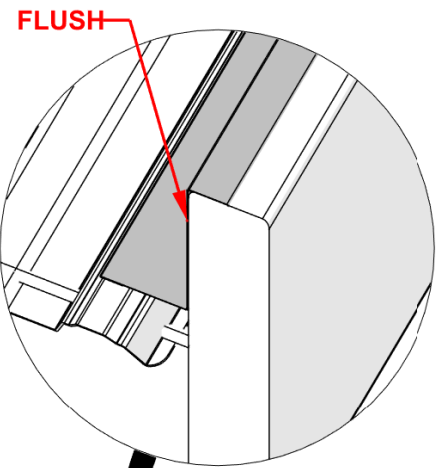
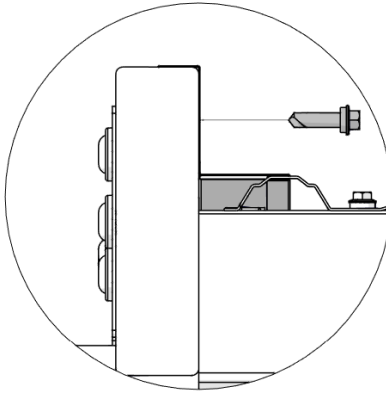
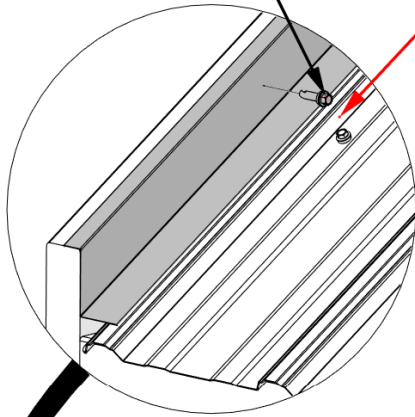

CENTER HARDWARE ALONG ROOF END TRIM AS SHOWN

4325 (x1) ROOF END TRIM

PEAK

4326 (x1) ROOF END TRIM

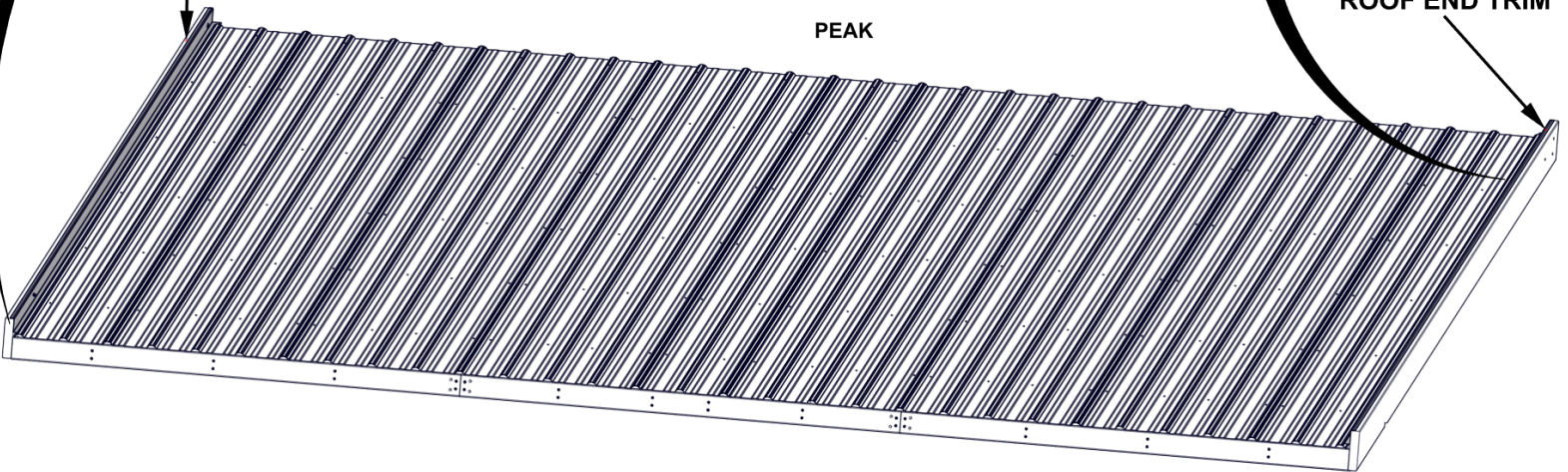

STEP 39 - ROOF PANEL 'B' ASSEMBLY

- SEPERATE ROOF PANEL FOR EASE OF ASSEMBLY.
- REMOVE HARDWARE AND SET ASIDE. IT WILL BE USED AGAIN AFTER BOTH SECTIONS ARE INSTALLED.

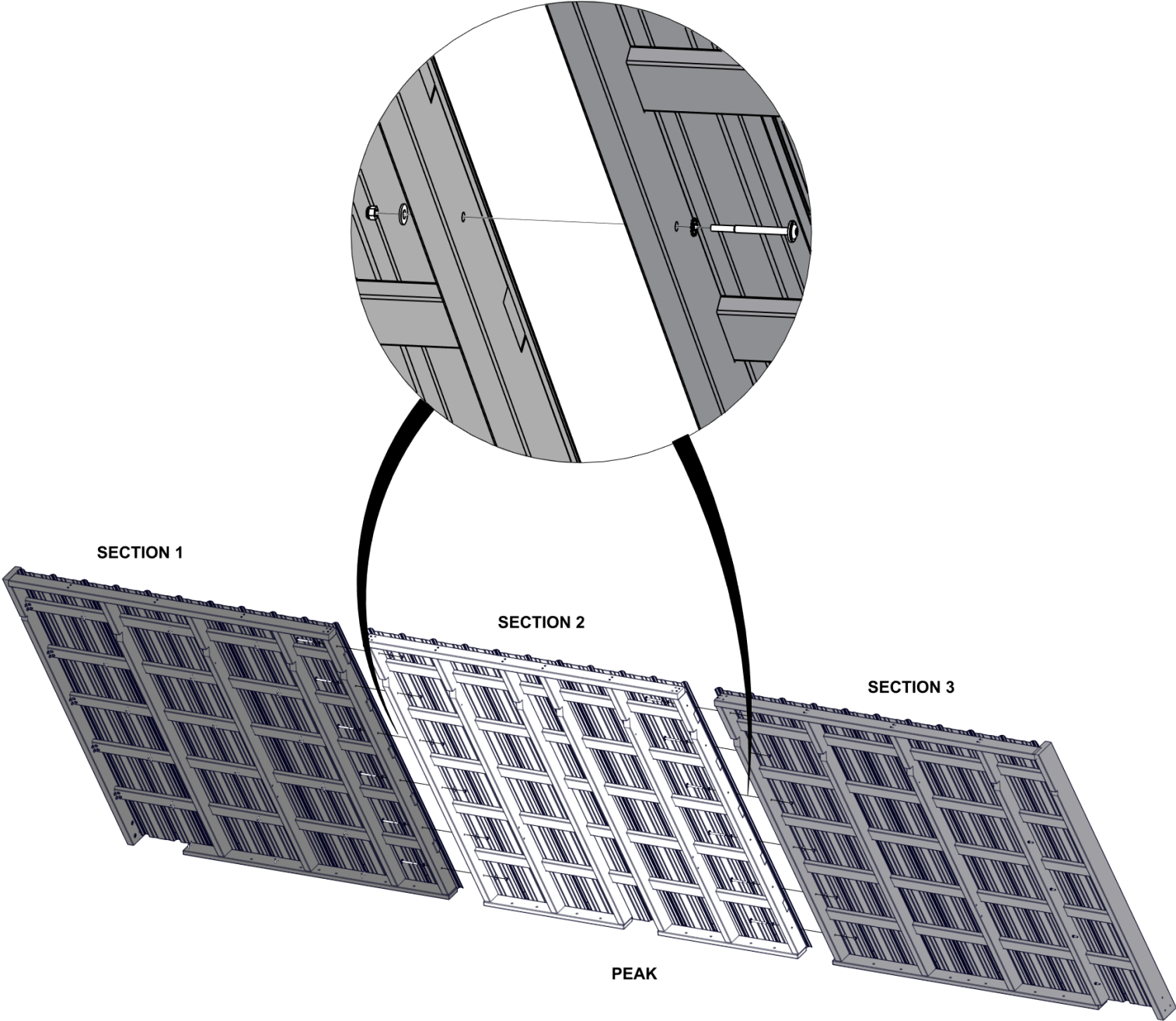

STEP 40 - ROOF ASSEMBLY

QTY	PART NUMBER	DESCRIPTION
3	H100195	BOLT WH 5/16x2 3/4 BLK
3	H100198	WASHER LOCK EXT 8x19

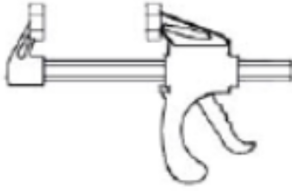

A6P00460 6" QUICK RELEASE CLAMP

- HAND TIGHTEN HARDWARE.

- ADDITIONAL PEOPLE ARE HELPFUL FOR THIS STEP.
- SLIDE ROOF PANEL ALONG GABLE BEAM.
- USE A6P00460 QUICK RELEASE CLAMPS IF NEEDED.

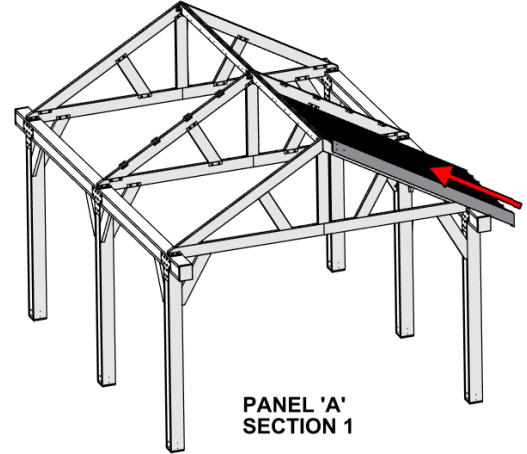

PANEL 'A'
SECTION 1

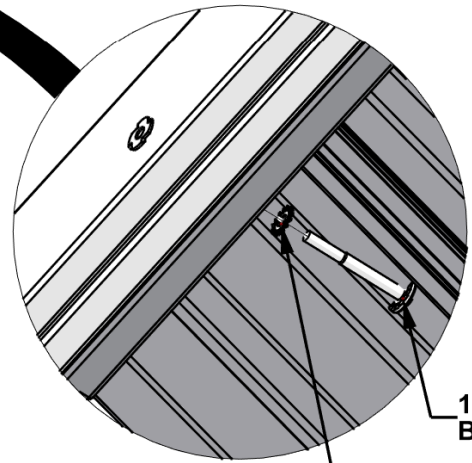
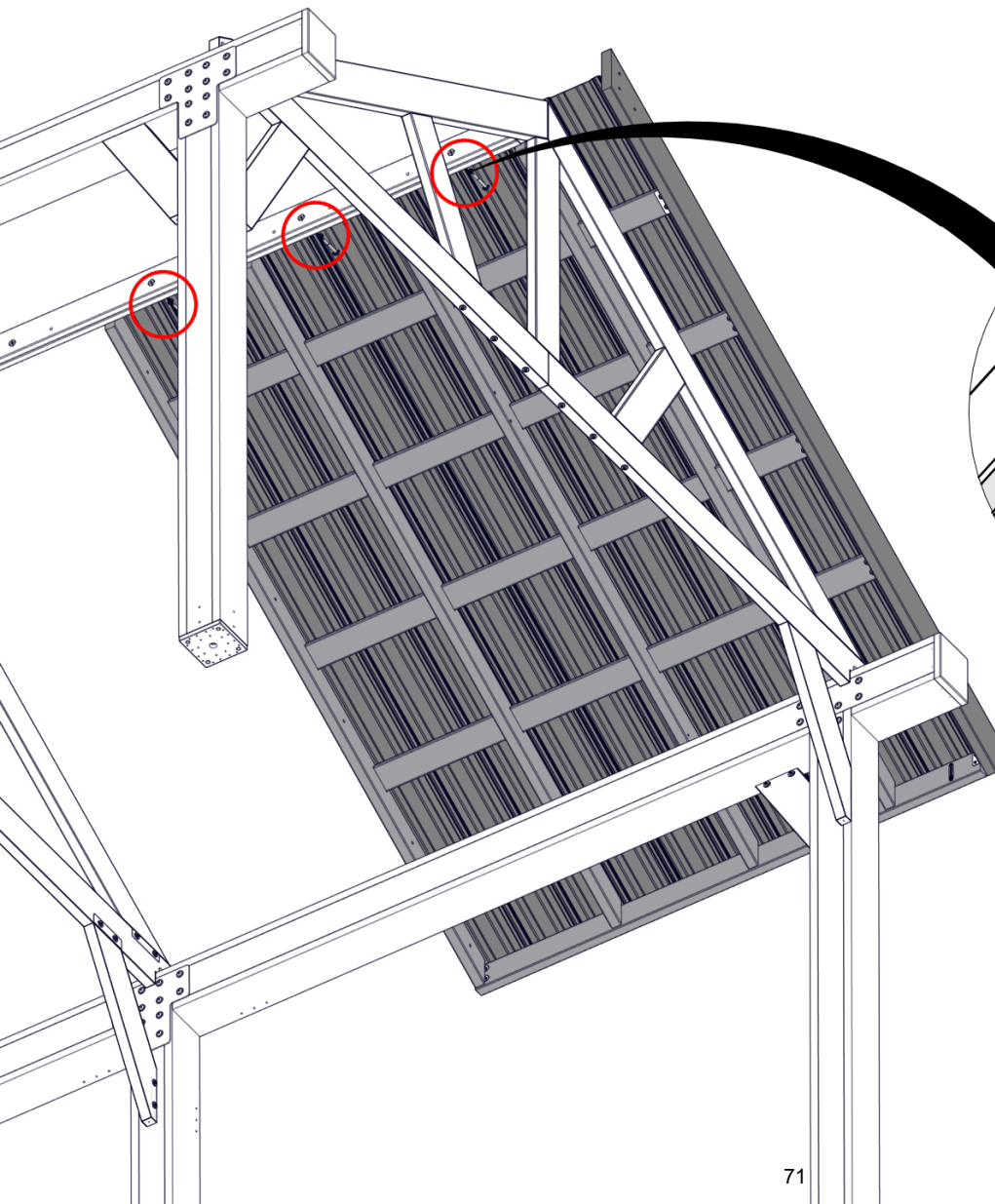

195 (x3)
BOLT-2 3/4"

198 (x3)
WASHER - 8x19

STEP 41 - ROOF ASSEMBLY

QTY	PART NUMBER	DESCRIPTION
4	H100198	WASHER LOCK EXT 8x19
4	H100479	NUT LOCK 5/16 BLK
4	H100534	BOLT WH 5/16x4 1/2 BLK
4	H100630	WASHER FLAT 8x19 BLK

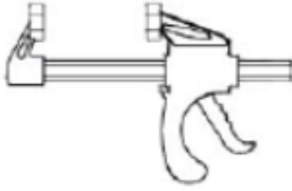

A6P00460 6" QUICK RELEASE CLAMP

- HAND TIGHTEN HARDWARE.

- ADDITIONAL PEOPLE ARE HELPFUL FOR THIS STEP.
- SLIDE ROOF PANEL ALONG GABLE BEAM.
- USE A6P00460 QUICK RELEASE CLAMPS IF NEEDED.

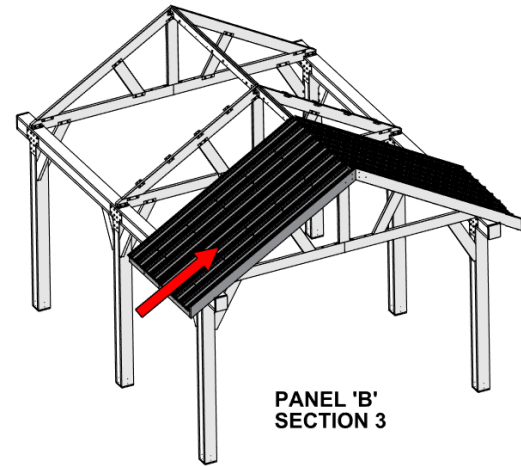

479 (x4)
LOCK NUT - 5/16"

630 (x4)
WASHER - 8x19

534 (x4)
BOLT - 4 1/2"
198 (x4)
WASHER - 8x19

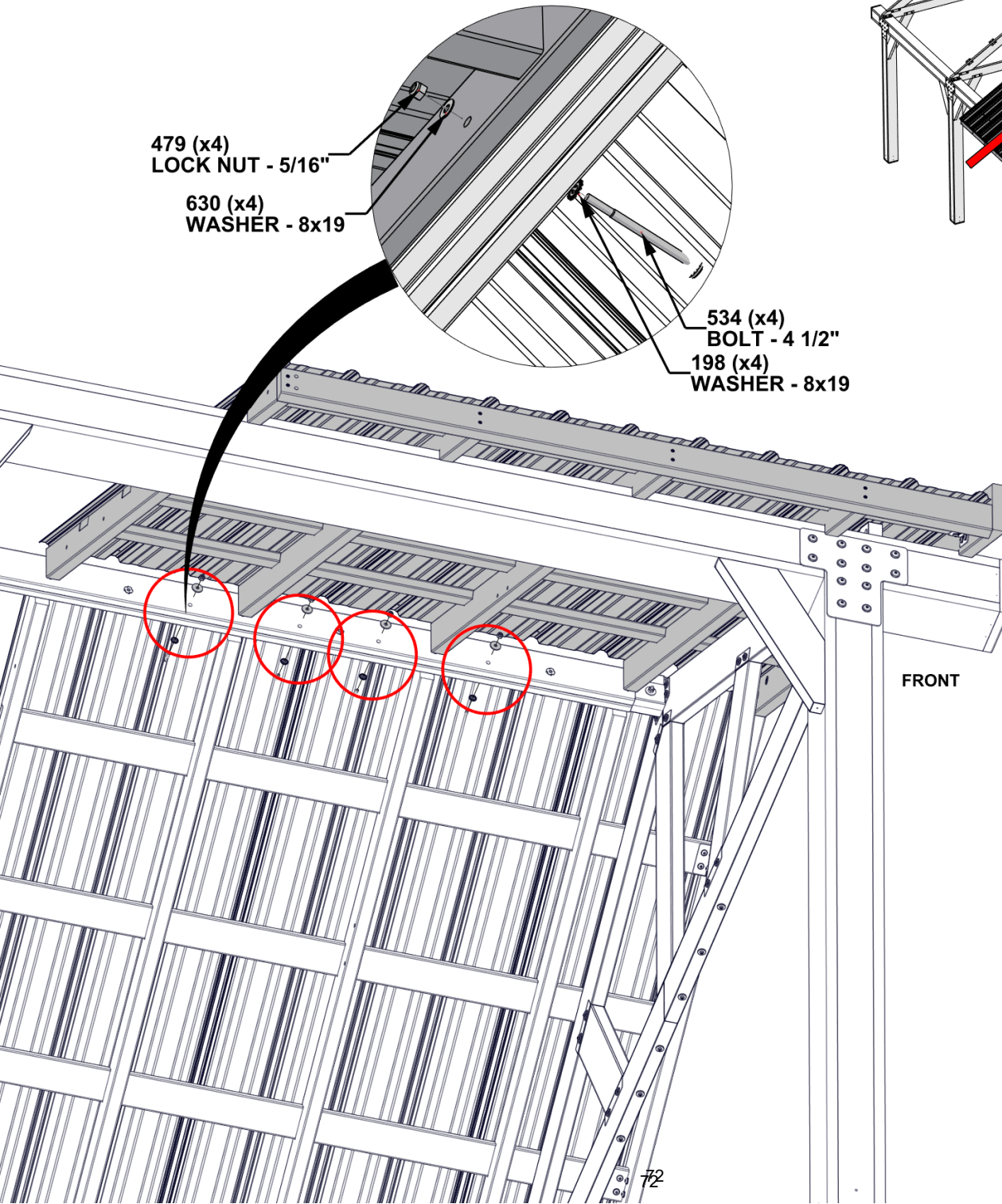

FRONT

STEP 42 - ROOF ASSEMBLY

QTY	PART NUMBER	DESCRIPTION
6	H100459	BOLT WH 5/16x1 1/4 BLK

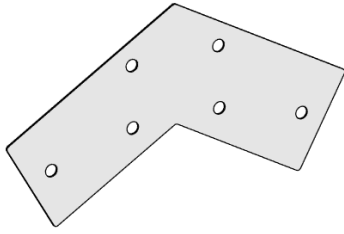

A4M02086 GABLE BRACKET
(x1)

- FASTEN HARDWARE INTO T-NUTS INSTALLED IN D01 AND D02 BOARDS.
- HAND TIGHTEN HARDWARE.

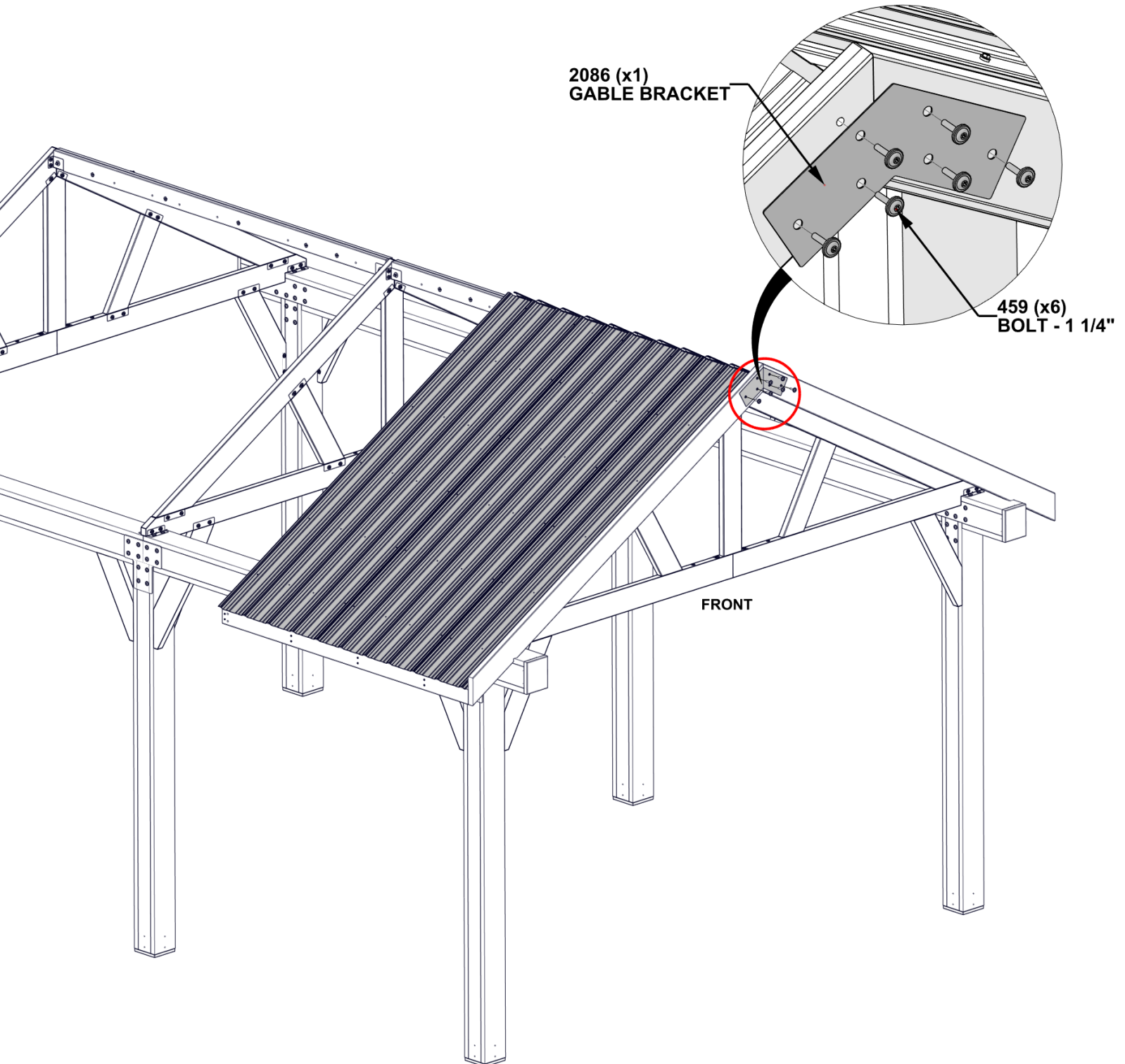

STEP 43 - ROOF ASSEMBLY

CRITICAL:

- IT IS IMPORTANT THAT THE PANELS ARE INSTALLED AS SHOWN.
- PARTIAL RIB MUST BE INSTALLED UNDER FULL RIB.
- FAILURE TO DO SO WILL RESULT IN LEAKING.
- MUST SLIDE PANEL UP FROM BOTTOM WITH RIBS OVERLAPPED.

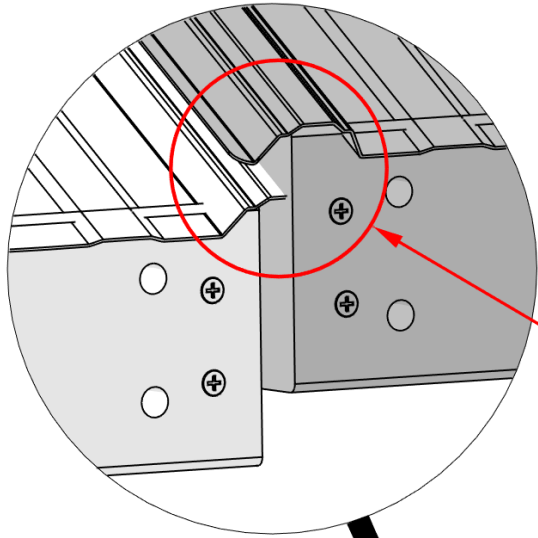
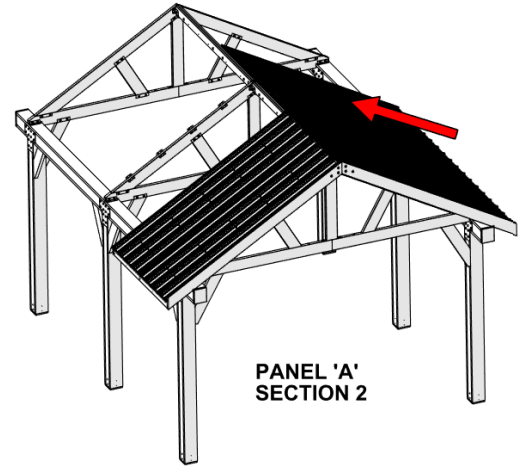

ENSURE FULL RIB
IS ATTACHED ON
TOP OF PARTIAL RIB

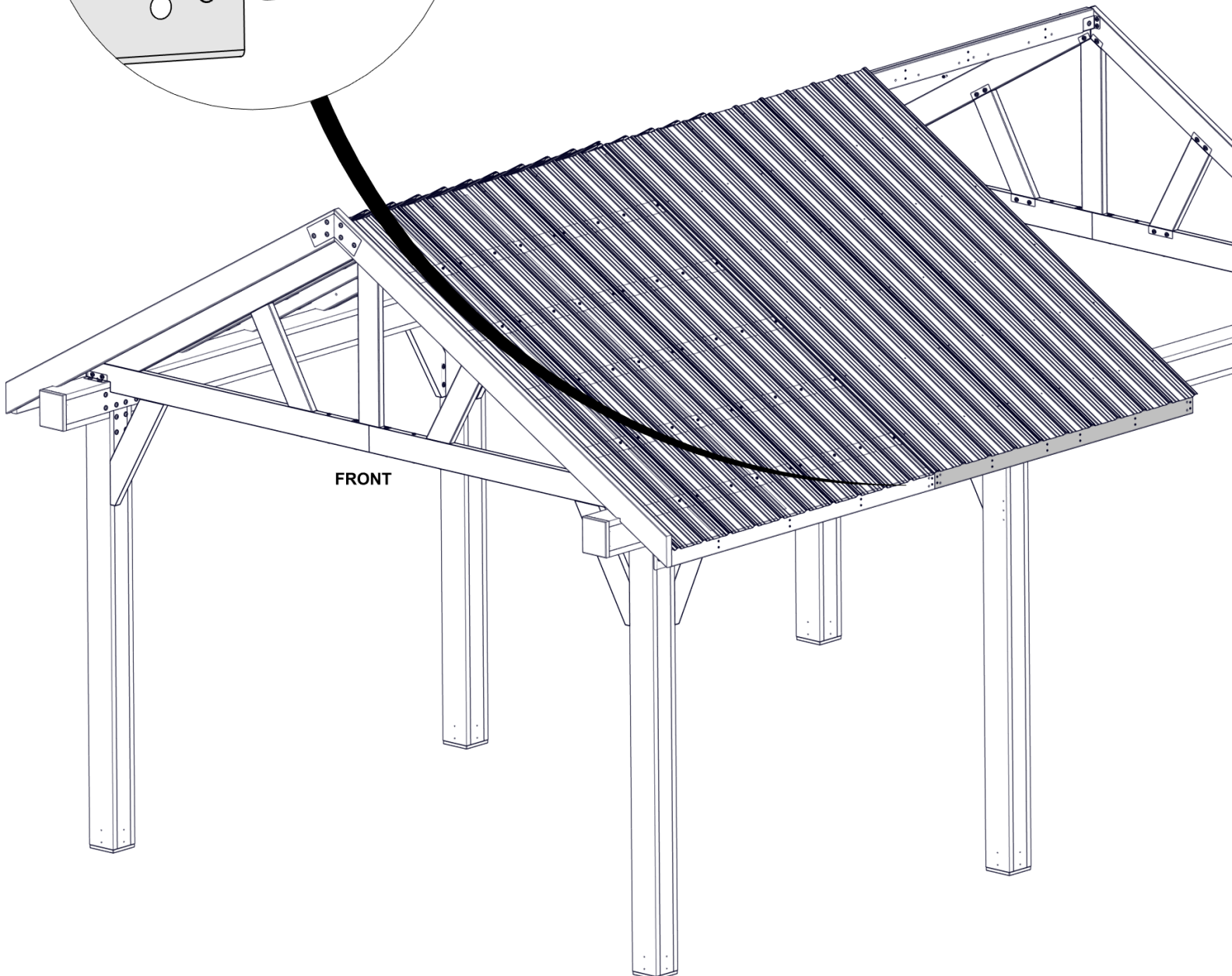

STEP 44 - ROOF ASSEMBLY

QTY	PART NUMBER	DESCRIPTION
4	H100195	BOLT WH 5/16x2 3/4 BLK
4	H100198	WASHER LOCK EXT 8x19

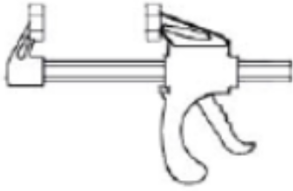

A6P00460 6" QUICK RELEASE CLAMP

- HAND TIGHTEN HARDWARE.

- ADDITIONAL PEOPLE ARE HELPFUL FOR THIS STEP.
- SLIDE ROOF PANEL ALONG GABLE BEAM.
- USE A6P00460 QUICK RELEASE CLAMPS IF NEEDED.

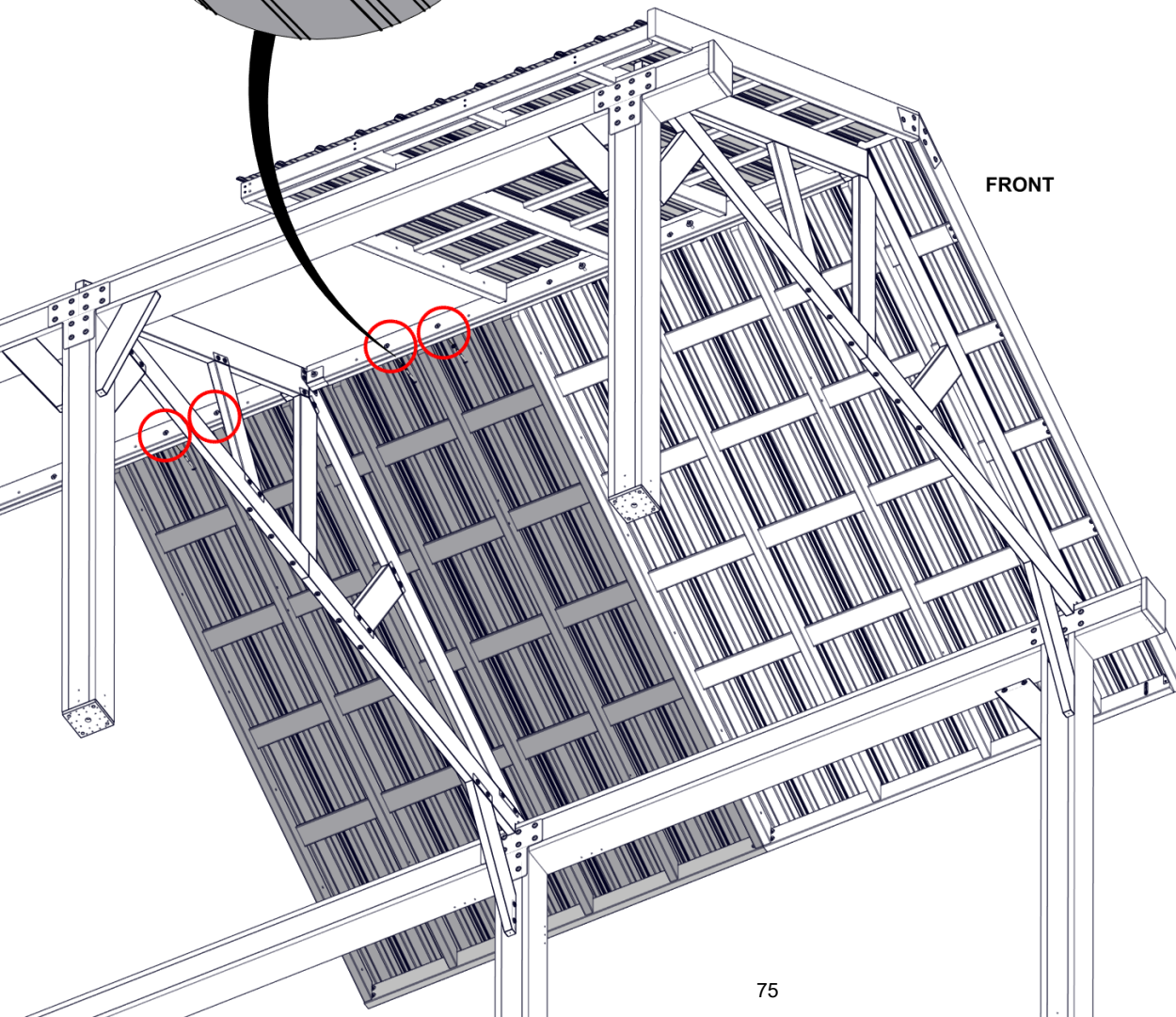
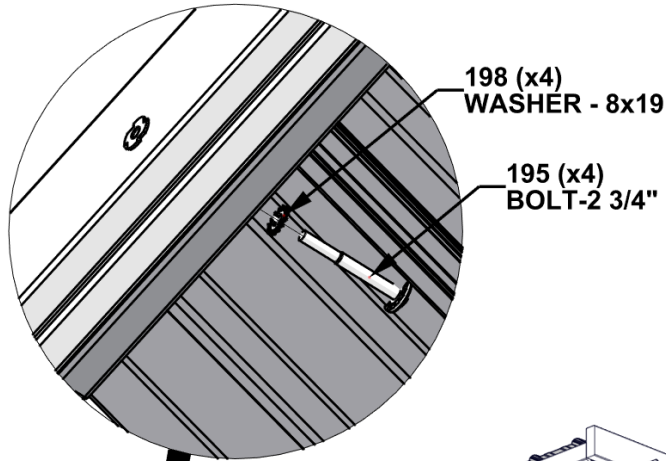
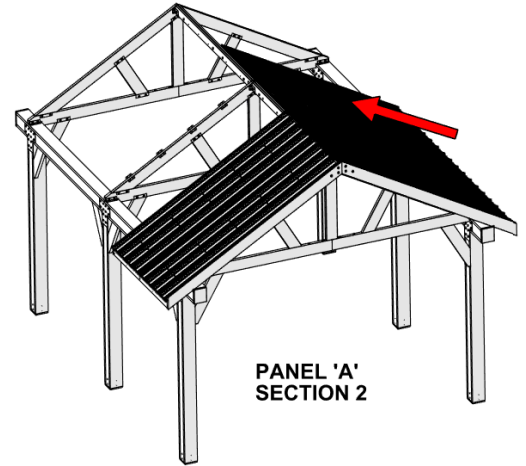

STEP 45 - ROOF ASSEMBLY

QTY	PART NUMBER	DESCRIPTION
6	H100198	WASHER LOCK EXT 8x19
6	H100478	WASHER FLAT 8x27 BLK
6	H100479	NUT LOCK 5/16 BLK
6	H100503	BOLT WH 5/16x3 1/2 BLK

- HAND TIGHTEN HARDWARE.

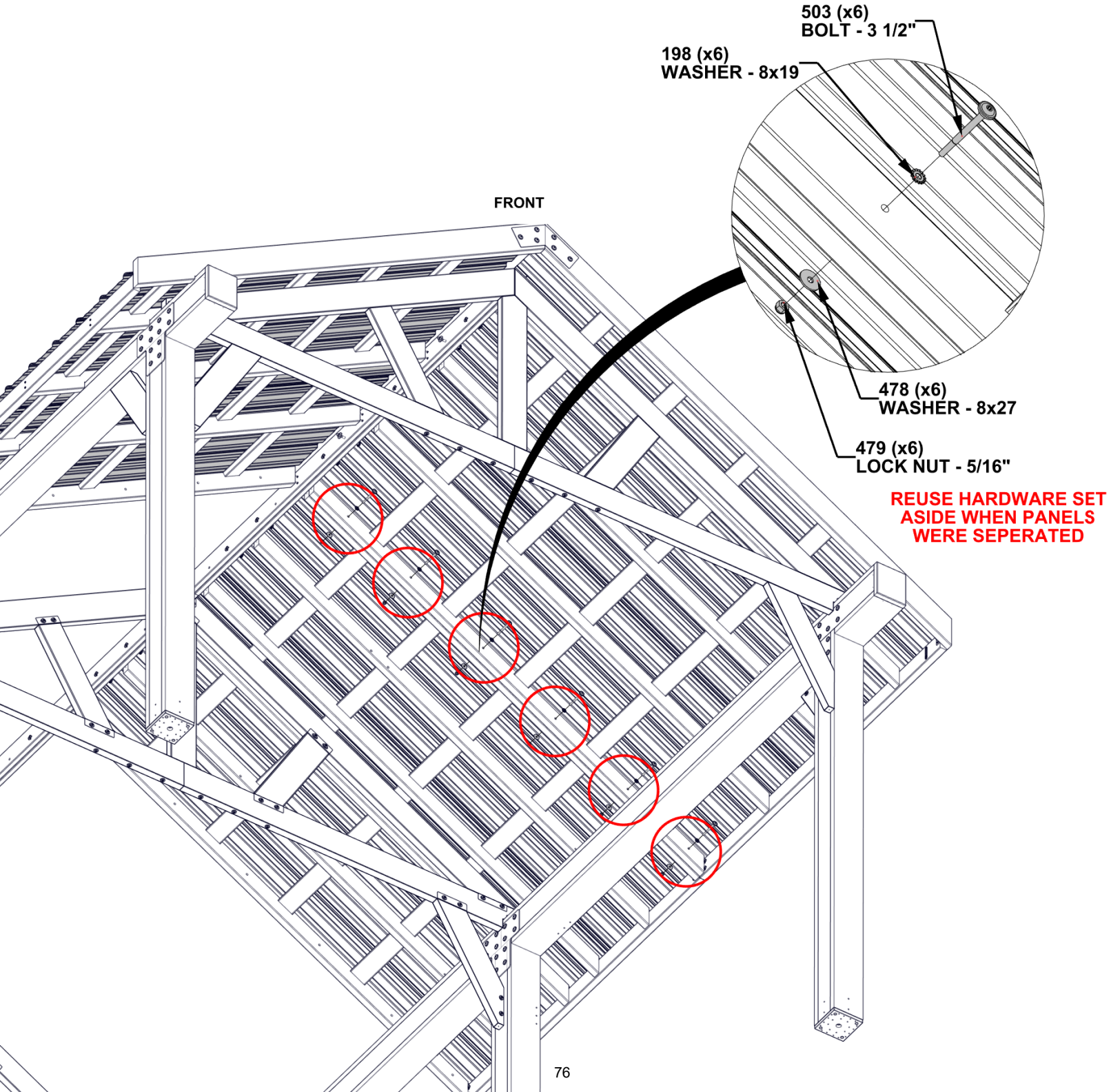

STEP 46 - ROOF ASSEMBLY

CRITICAL:

- IT IS IMPORTANT THAT THE PANELS ARE INSTALLED AS SHOWN.
- PARTIAL RIB MUST BE INSTALLED UNDER FULL RIB.
- FAILURE TO DO SO WILL RESULT IN LEAKING.
- MUST SLIDE PANEL UP FROM BOTTOM WITH RIBS OVERLAPPING.

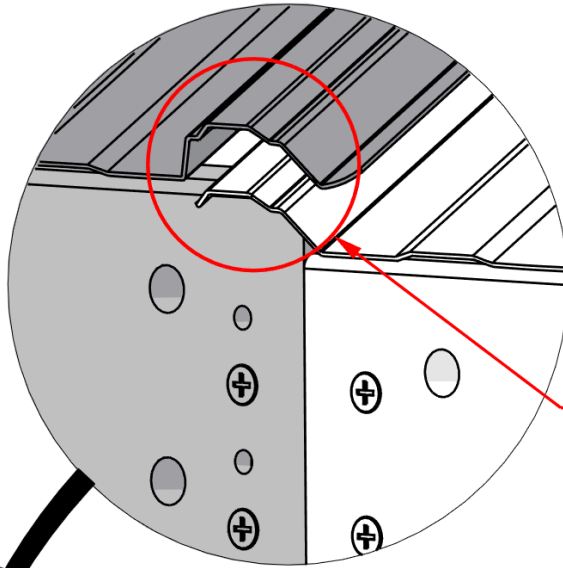
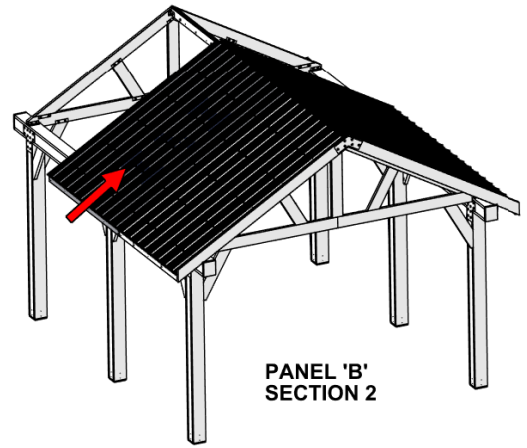

ENSURE FULL RIB IS
ATTACHED ON TOP
OF PARTIAL RIB

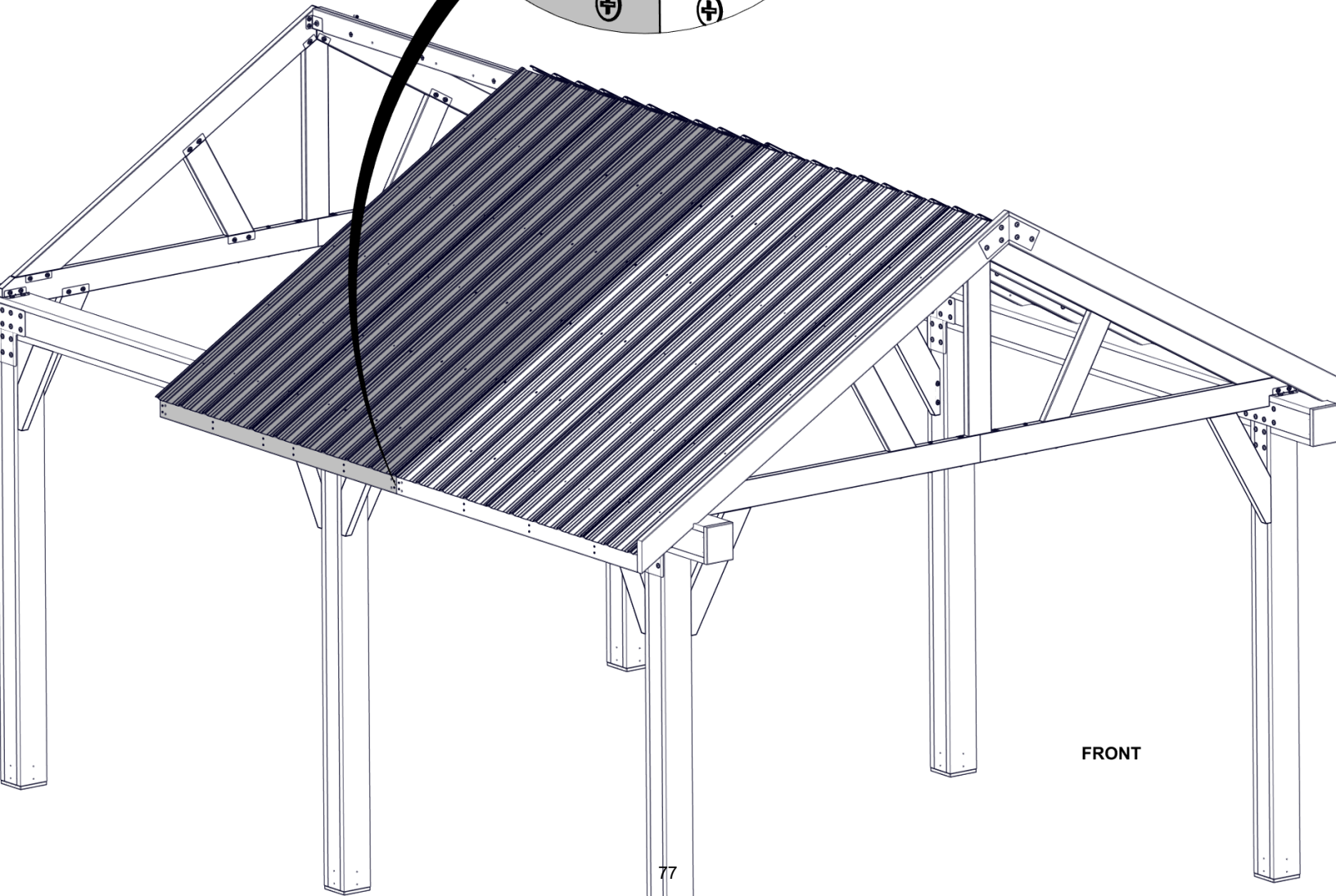

STEP 47 - ROOF ASSEMBLY

QTY	PART NUMBER	DESCRIPTION
4	H100198	WASHER LOCK EXT 8x19
4	H100479	NUT LOCK 5/16 BLK
4	H100534	BOLT WH 5/16x4 1/2 BLK
4	H100630	WASHER FLAT 8x19 BLK

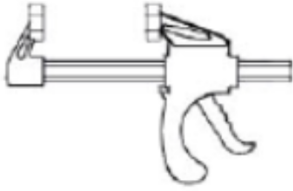

A6P00460 6" QUICK RELEASE CLAMP

479 (x4)
LOCK NUT - 5/16"

630 (x4)
WASHER - 8x19

198 (x4)
WASHER - 8x19

534 (x4)
BOLT - 4 1/2"

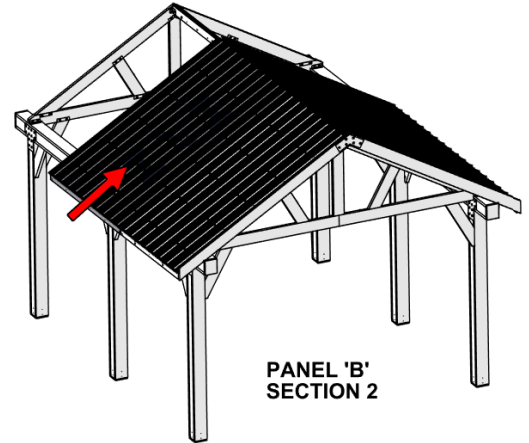

PANEL 'B'
SECTION 2

FRONT

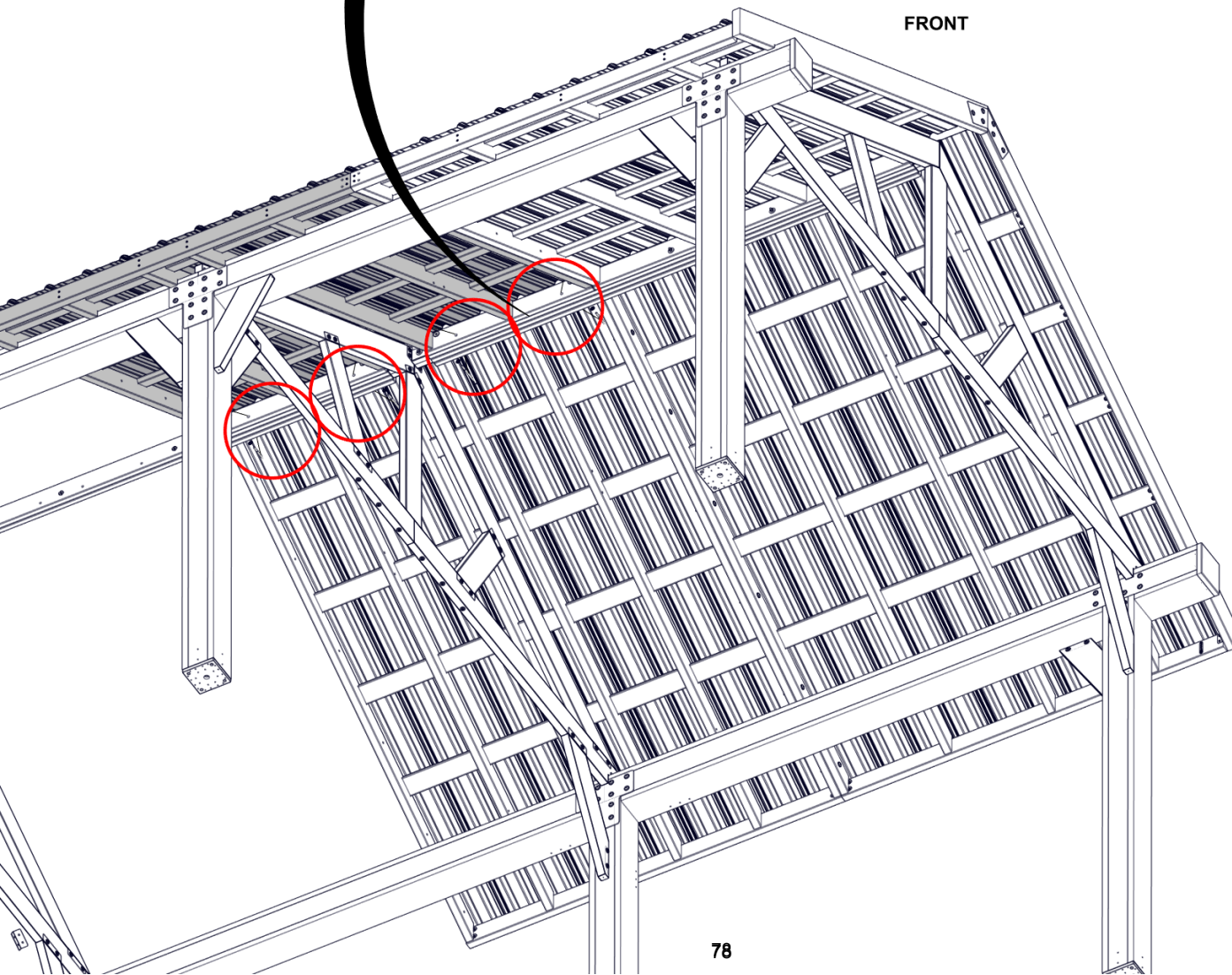

STEP 48 - ROOF ASSEMBLY

QTY	PART NUMBER	DESCRIPTION
6	H100198	WASHER LOCK EXT 8x19
6	H100478	WASHER FLAT 8x27 BLK
6	H100479	NUT LOCK 5/16 BLK
6	H100503	BOLT WH 5/16x3 1/2 BLK

- HAND TIGHTEN HARDWARE.

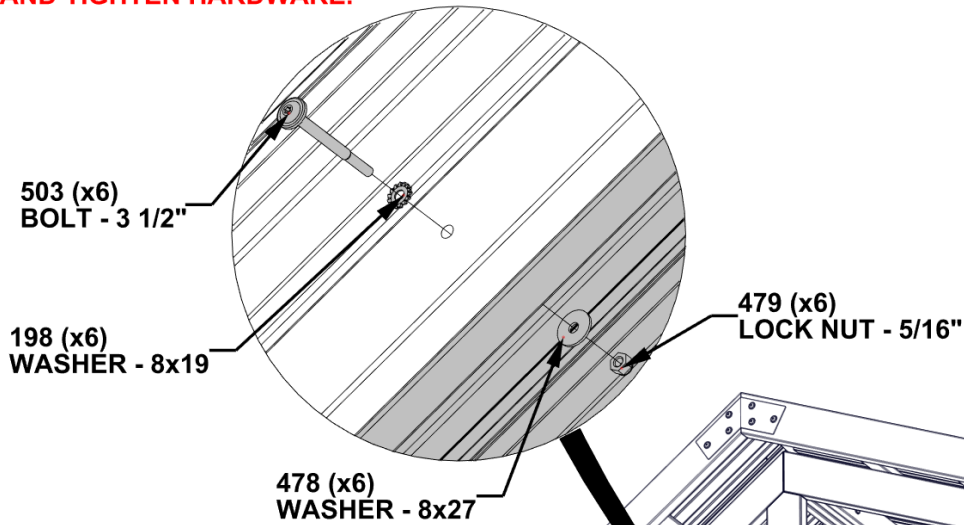

REUSE HARDWARE SET
ASIDE WHEN PANELS
WERE SEPERATED

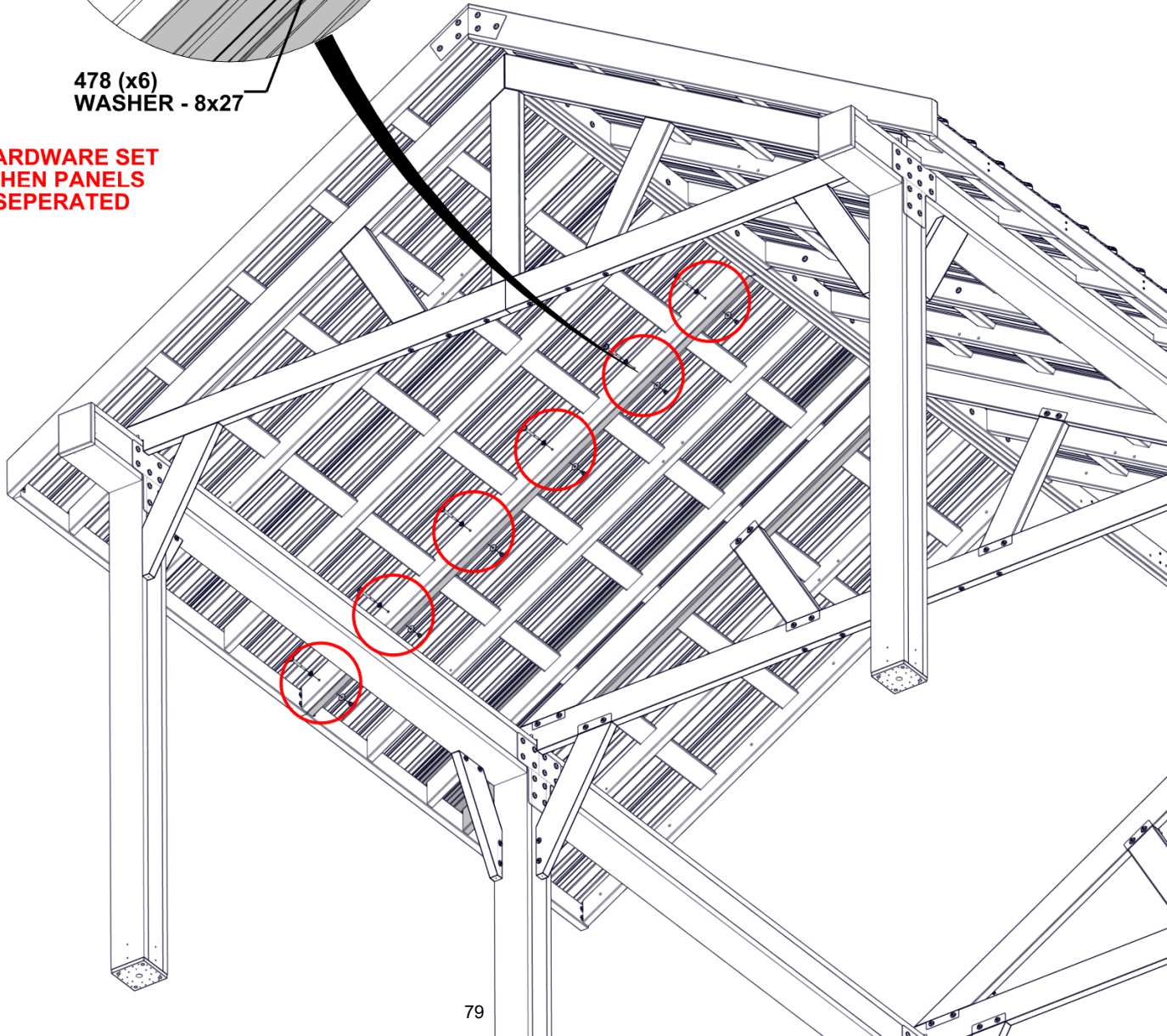

STEP 49A - RIDGE CAP ASSEMBLY

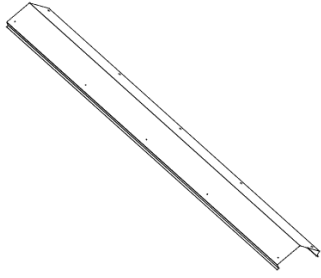

A4M05735 RIDGE CAP
(x3)

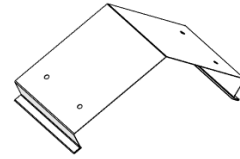

A4M04328 RIDGE CAP SPLICE
(x2)

- REMOVE PROTECTIVE BLUE FILM.
- GLOVES SHOULD BE WORN WHEN HANDLING ROOF PANELS: EDGES ARE SHARP.
- SLIDE EACH RIDGE CAP INTO THE RIDGE CAP SPLICE UNTIL CENTERED.

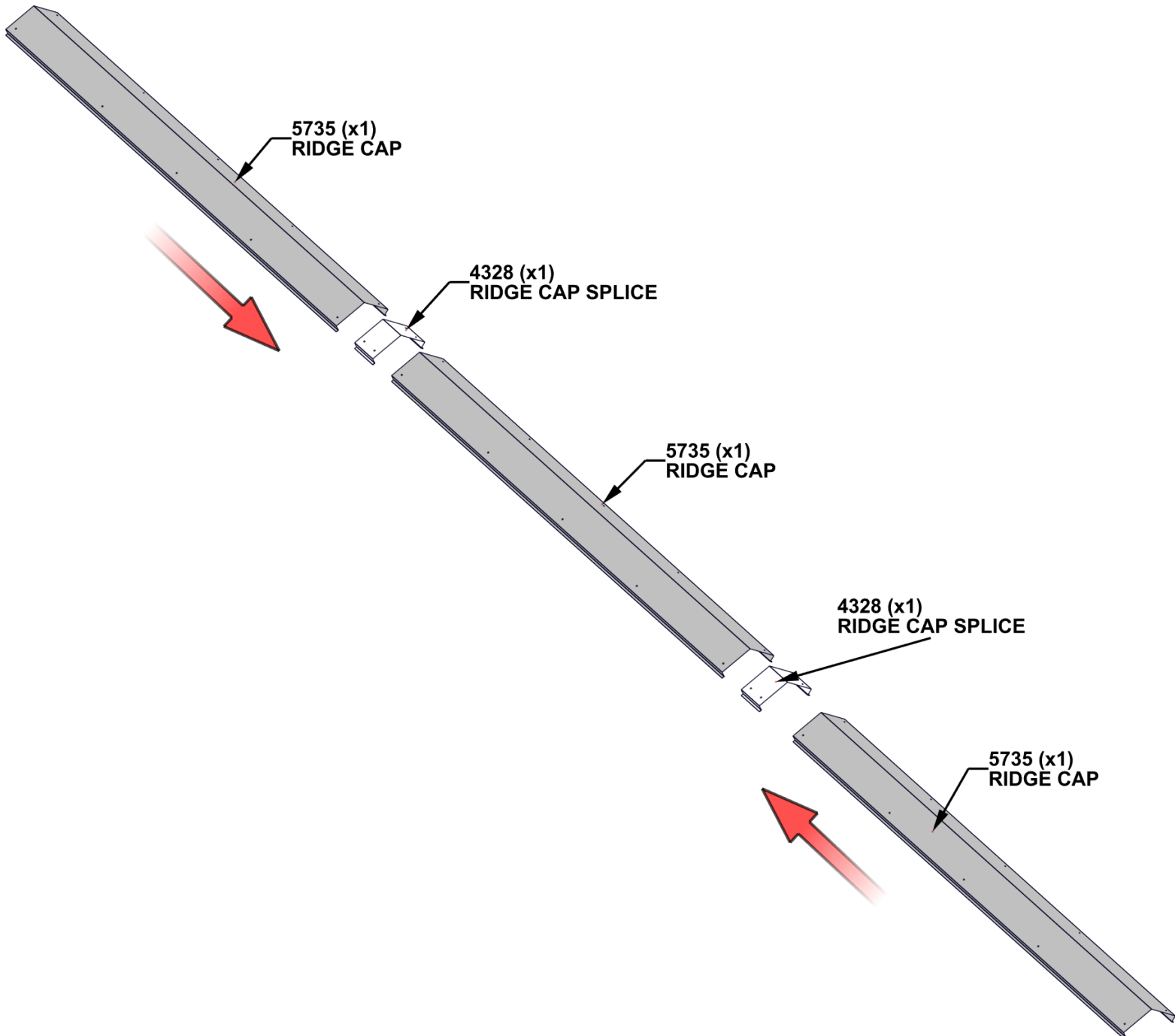

STEP 49B - RIDGE CAP ASSEMBLY

QTY	PART NUMBER	DESCRIPTION
26	H101117	SCREW WOODGRIP 10-16x3/4" BLK

J02 RIDGE CAP STIFFENER - W4L21177
(x2) 15/16"X2 3/8"X62 7/8" (24x60x1597)

J03 RIDGE CAP STIFFENER - W4L21180
(x2) 15/16"X2 3/8"X82 5/8" (24x60x2100)

J04 RIDGE CAP STIFFENER - W4L22018
(x2) 15/16"X2 3/8"X71 3/4" (24x60x1821)

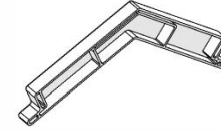

A6P00693 RIDGE CAP PROTECTOR
(x2)

- REMOVE SPACERS FROM RIDGE CAP PROTECTORS BEFORE INSTALLING.
- ALIGN THE HOLES ON EACH RIDGE CAP WITH THE HOLES IN THE RIDGE CAP SPLICE BEFORE INSERTING.

- FINAL ASSEMBLED LENGTH: 18'-1 3/8" [5522mm]

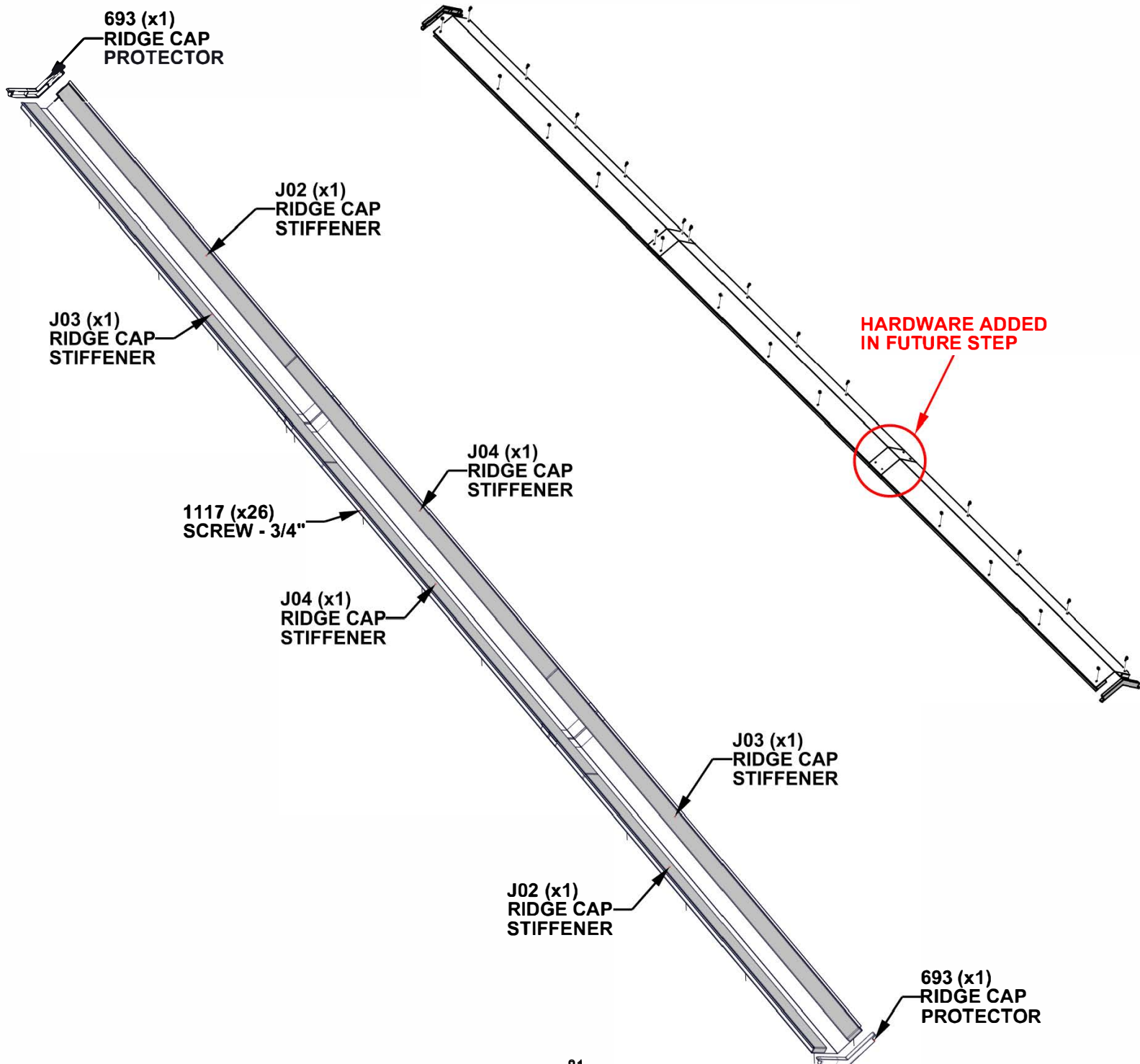

STEP 49C - RIDGE CAP ASSEMBLY

- SLIDE RIDGE CAP APART AS SHOWN. SET 4328 RIDGE CAP SPLICE AND ASSEMBLY B ASIDE FOR LATER USE.

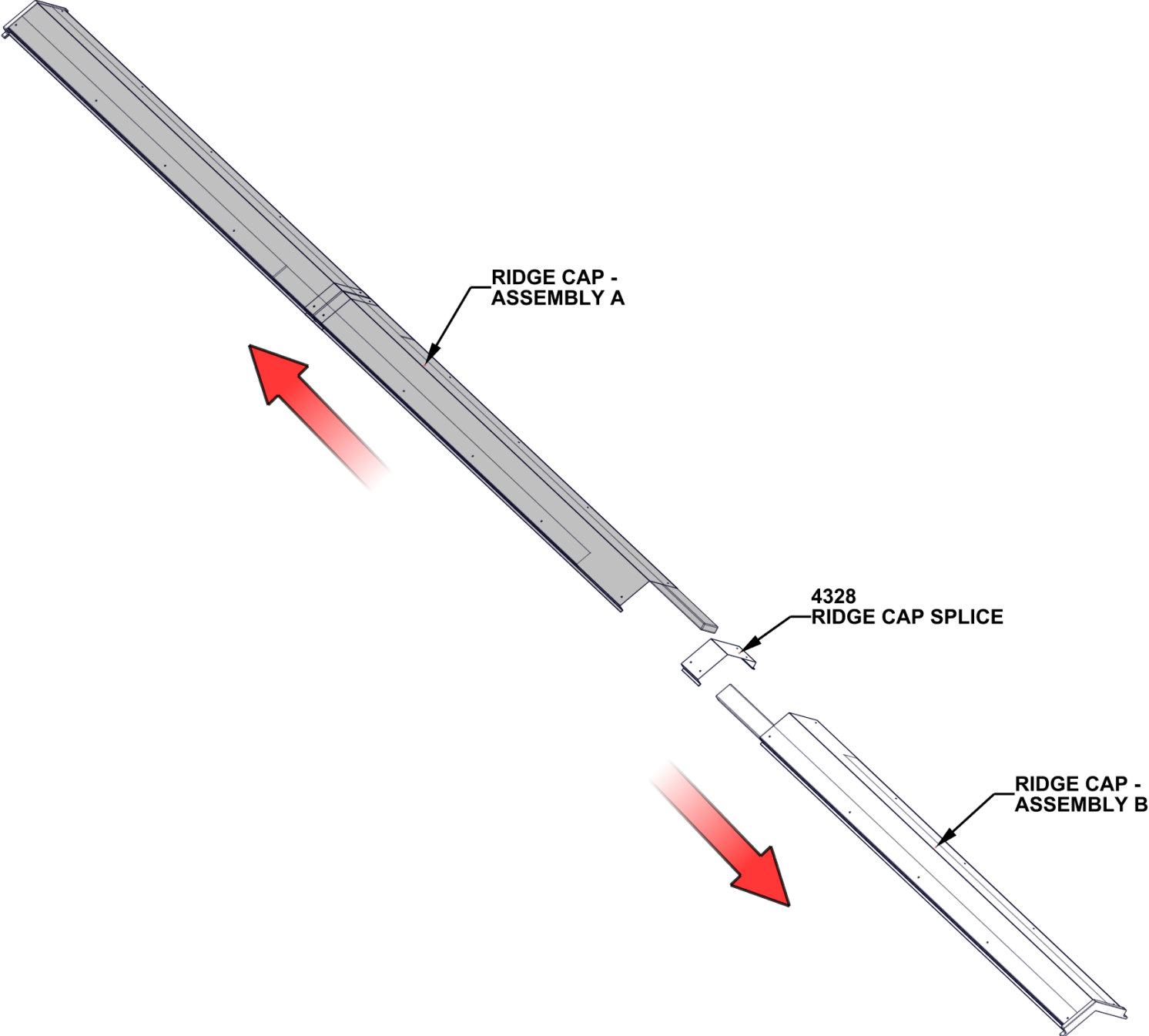

STEP 50 - RIDGE CAP ASSEMBLY

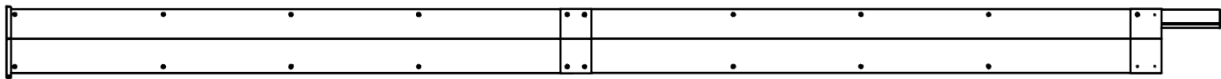

RIDGE CAP - ASSEMBLY A

DO NOT CLIMB ON ROOF TO INSTALL. RIDGE CAP AS BEEN DESIGNED TO INSTALL WITH THE USE OF A LADDER.

INSTALL RIDGE CAP WITH APPROXIMATELY 1/8" [3mm] GAP FROM FASCIA BOARD

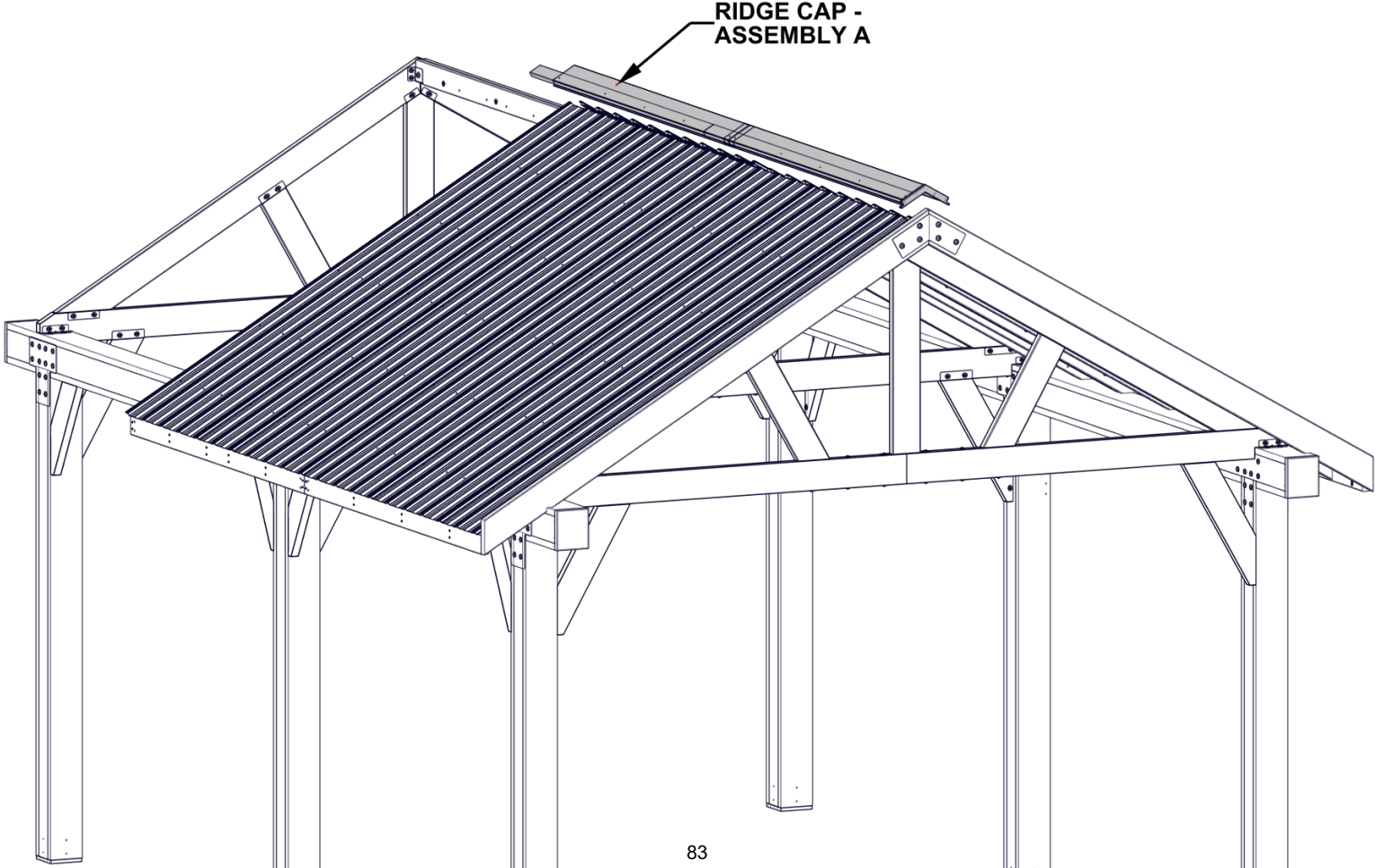
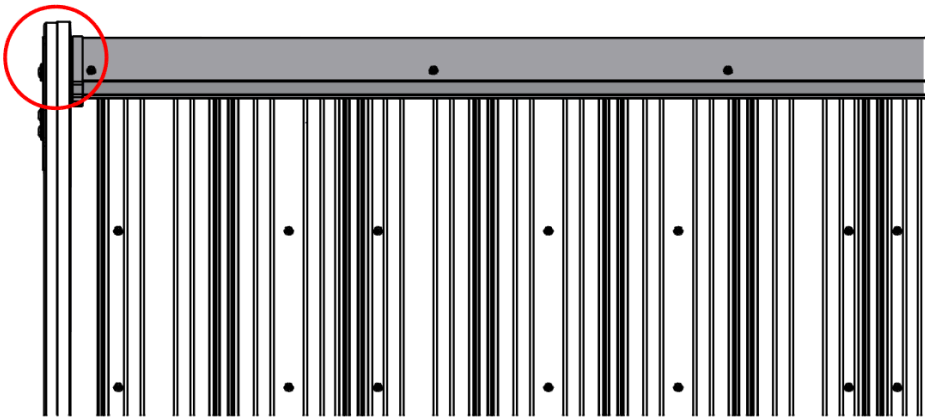

RIDGE CAP - ASSEMBLY A

STEP 51 - ROOF ASSEMBLY

QTY	PART NUMBER	DESCRIPTION
3	H100195	BOLT WH 5/16x2 3/4 BLK
3	H100198	WASHER LOCK EXT 8x19

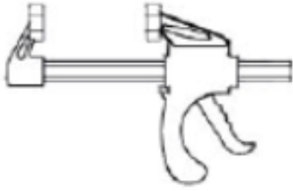

A6P00460 6" QUICK RELEASE CLAMP

- HAND TIGHTEN HARDWARE.

- ADDITIONAL PEOPLE ARE HELPFUL FOR THIS STEP.
- SLIDE ROOF PANEL ALONG GABLE BEAM.
- ALIGN HOLES AND ATTACH HARDWARE AS SHOWN.
- USE A6P00460 QUICK RELEASE CLAMPS IF NEEDED.

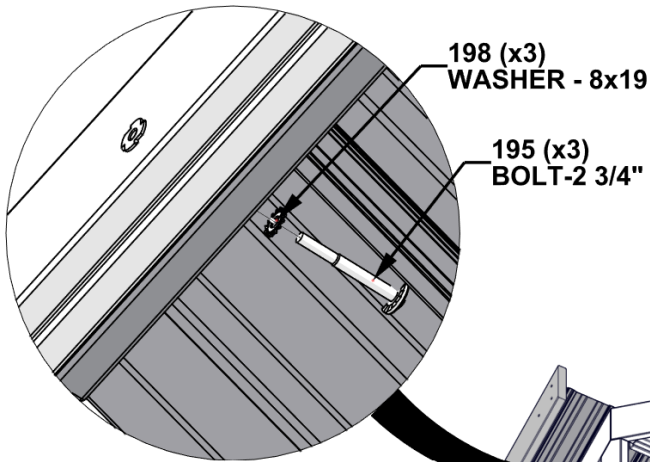
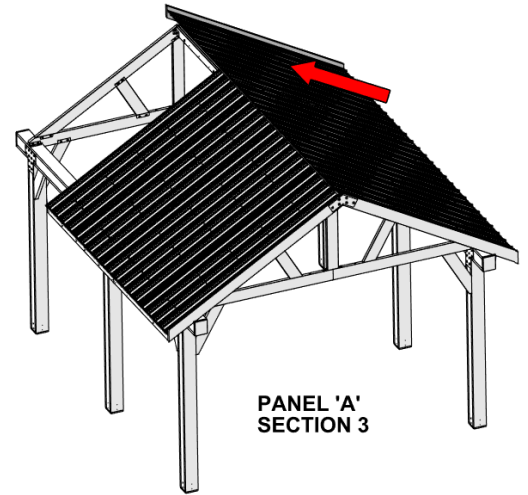

BACK

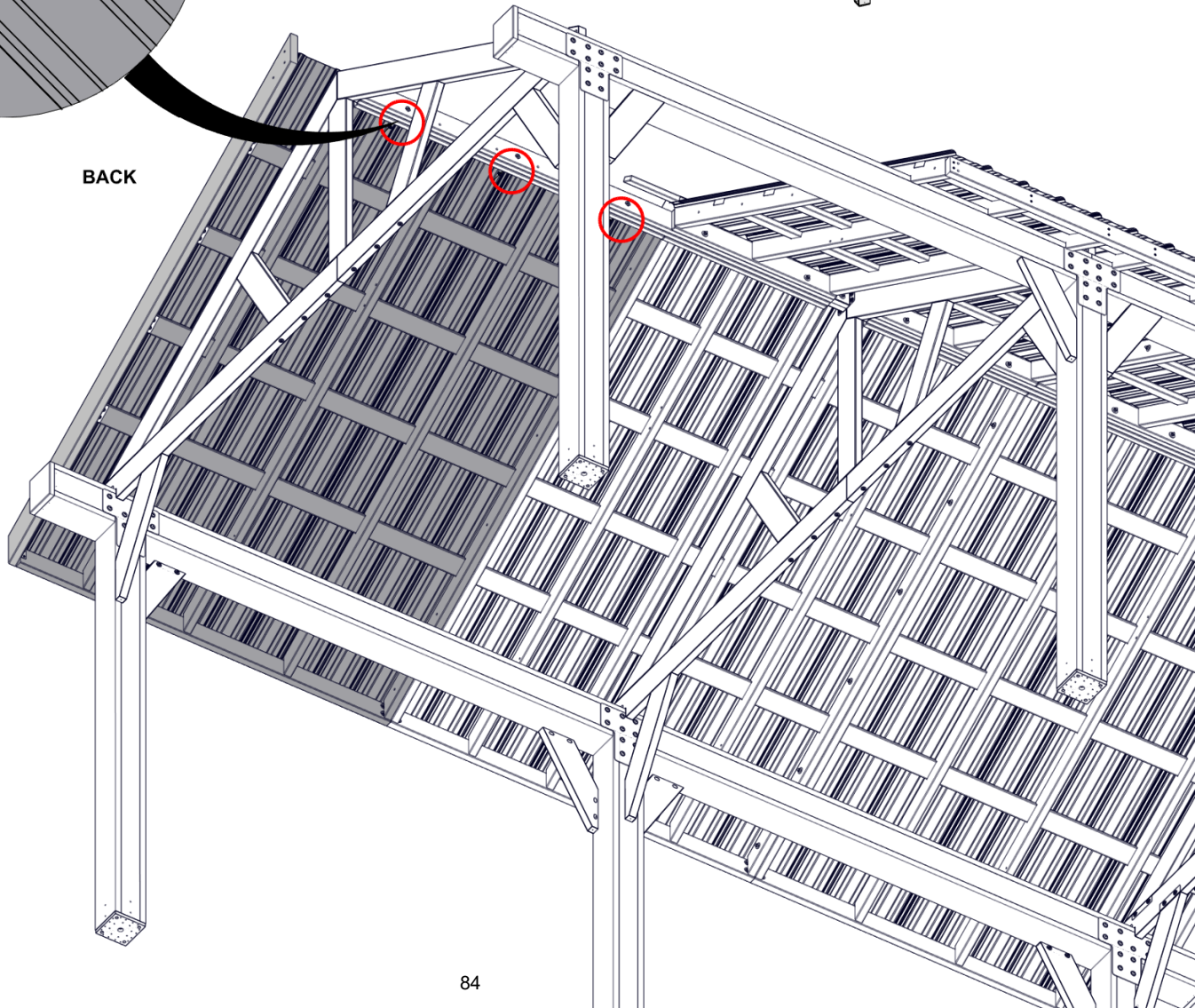

STEP 52 - ROOF ASSEMBLY

QTY	PART NUMBER	DESCRIPTION
6	H100198	WASHER LOCK EXT 8x19
6	H100478	WASHER FLAT 8x27 BLK
6	H100479	NUT LOCK 5/16 BLK
6	H100503	BOLT WH 5/16x3 1/2 BLK

- HAND TIGHTEN HARDWARE.

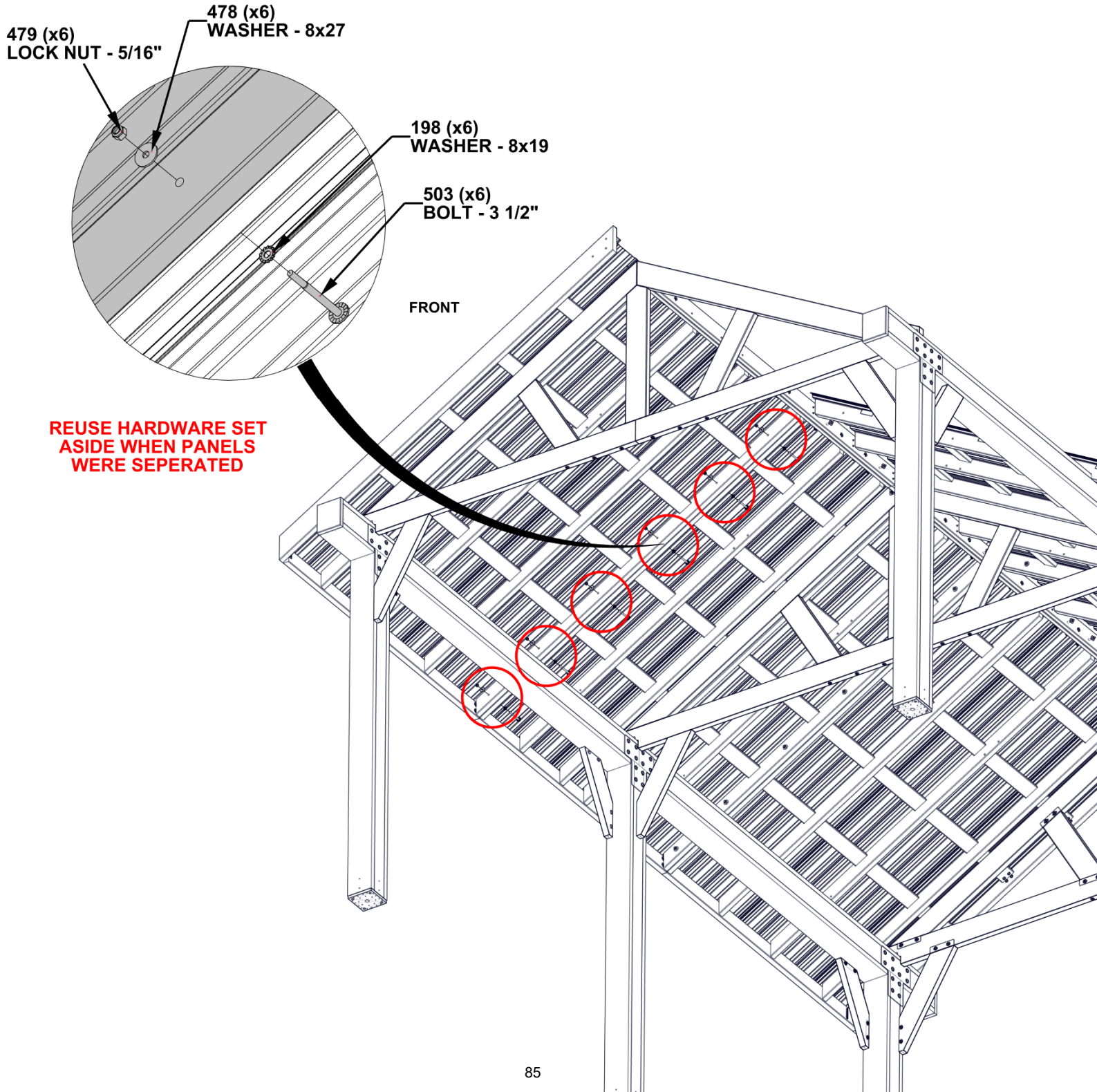

STEP 53 - ROOF ASSEMBLY

QTY	PART NUMBER	DESCRIPTION
4	H100392	SCREW PWH 8x3/4 BLK
4	H101117	SCREW WOODGRIP 10-16x3/4" BLK

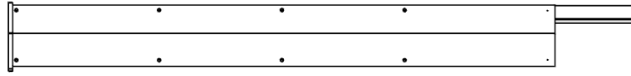

RIDGE CAP - ASSEMBLY B

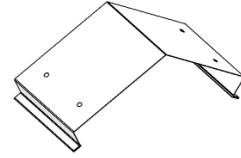

A4M04328 RIDGE CAP SPLICE (x1)

DO NOT CLIMB ON ROOF TO INSTALL. RIDGE CAP AS BEEN DESIGNED TO INSTALL WITH THE USE OF A LADDER.

- FOR PROPER INSTALLATION, USE AN ADULT HELPER TO KEEP DOWNWARD PRESSURE ON THE RIDGE CAP WHILE SCREWING IN SCREWS.

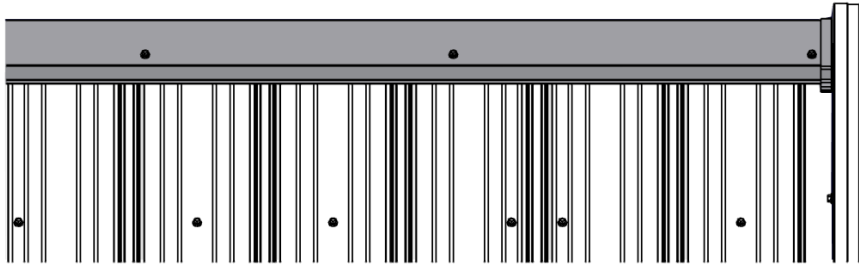

INSTALL THE RIDGE CAP WITH APPROXIMATELY 1/8" [3mm] GAP FROM FASCIA BOARDS

1117 (x4) SCREW - 3/4"

4328 (x1) RIDGE CAP SPLICE

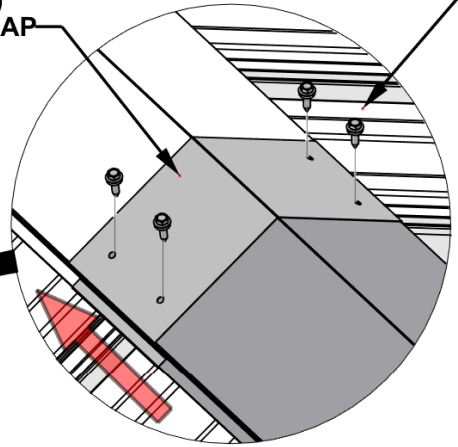

SLIDE RIDGE CAP SPLICE OVER RIDGE CAP - ASSEMBLY A PREVIOUSLY INSTALLED AND SLIDE RIDGE CAP STIFFENER UNDER RIDGE CAP ASSEMBLY. SLIDE RIDGE CAP - ASSEMBLY B INTO RIDGE CAP SPLICE, ALIGN HOLES, AND ATTACH WITH HARDWARE AS SHOWN

RIDGE CAP - ASSEMBLY B

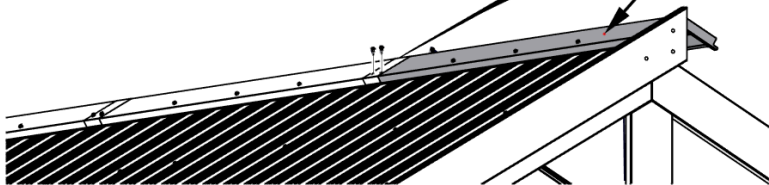

392 (x4) SCREW - 3/4"

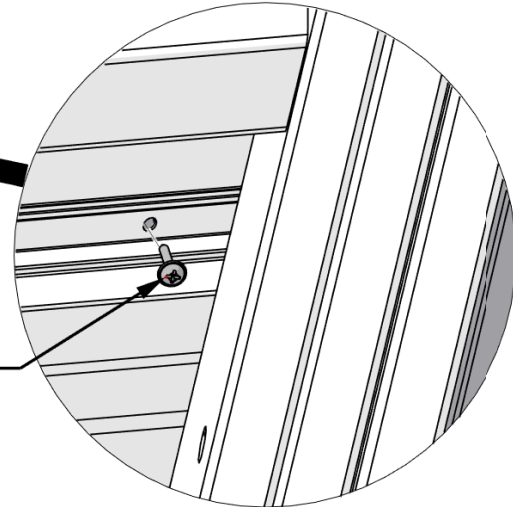

INSTALL SCREWS THROUGH PILOT HOLES IN ROOF PANELS INTO RIDGE CAP STIFFENER BOARDS USING THE H101114 RIGHT ANGLE DRILL ADAPTER ATTACHMENT INCLUDED

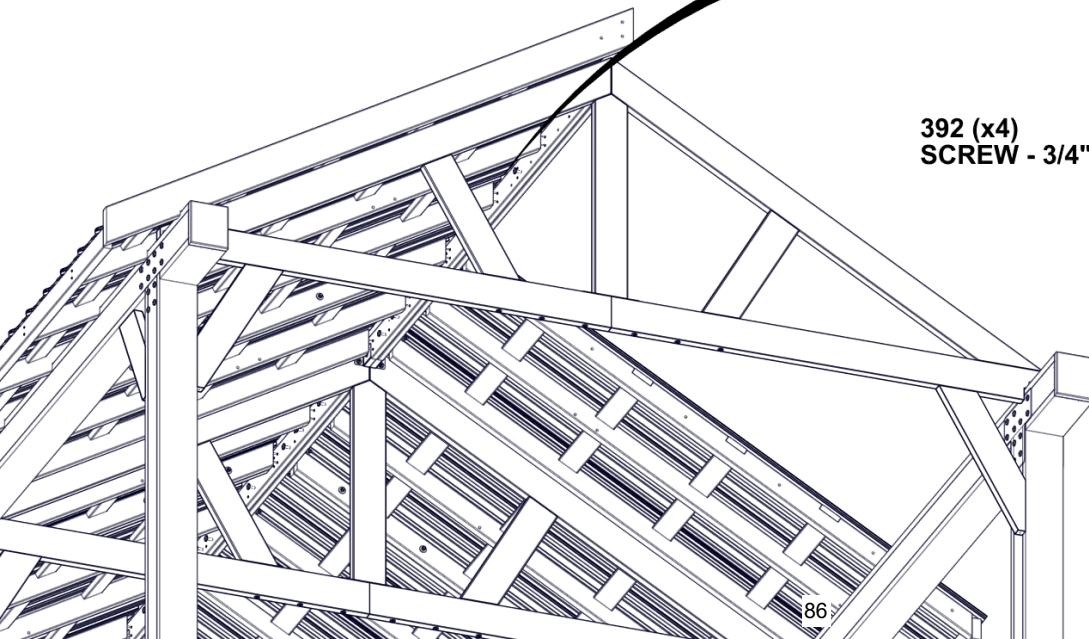

STEP 54 - ROOF ASSEMBLY

CRITICAL:

- IT IS IMPORTANT THAT THE PANELS ARE INSTALLED AS SHOWN.
- PARTIAL RIB MUST BE INSTALLED UNDER FULL RIB.
- FAILURE TO DO SO WILL RESULT IN LEAKING.
- MUST SLIDE PANEL UP FROM BOTTOM WITH RIBS OVERLAPPING.

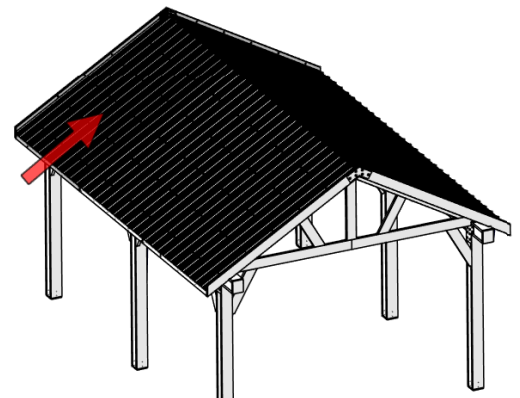

PANEL 'B'
SECTION 1

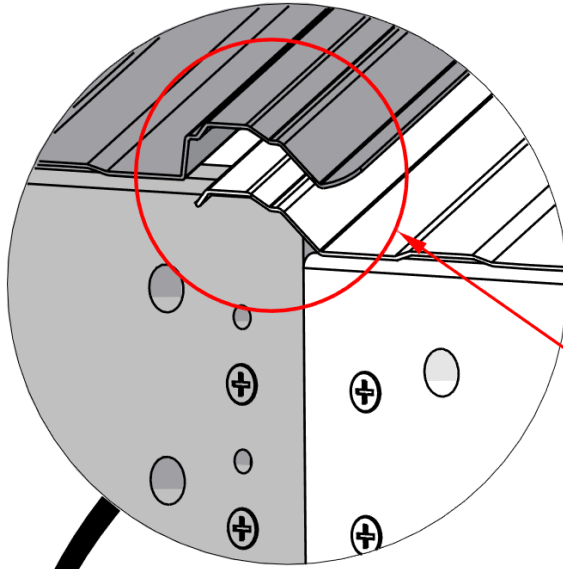

ENSURE FULL RIB
IS ATTACHED ON TOP
OF PARTIAL RIB

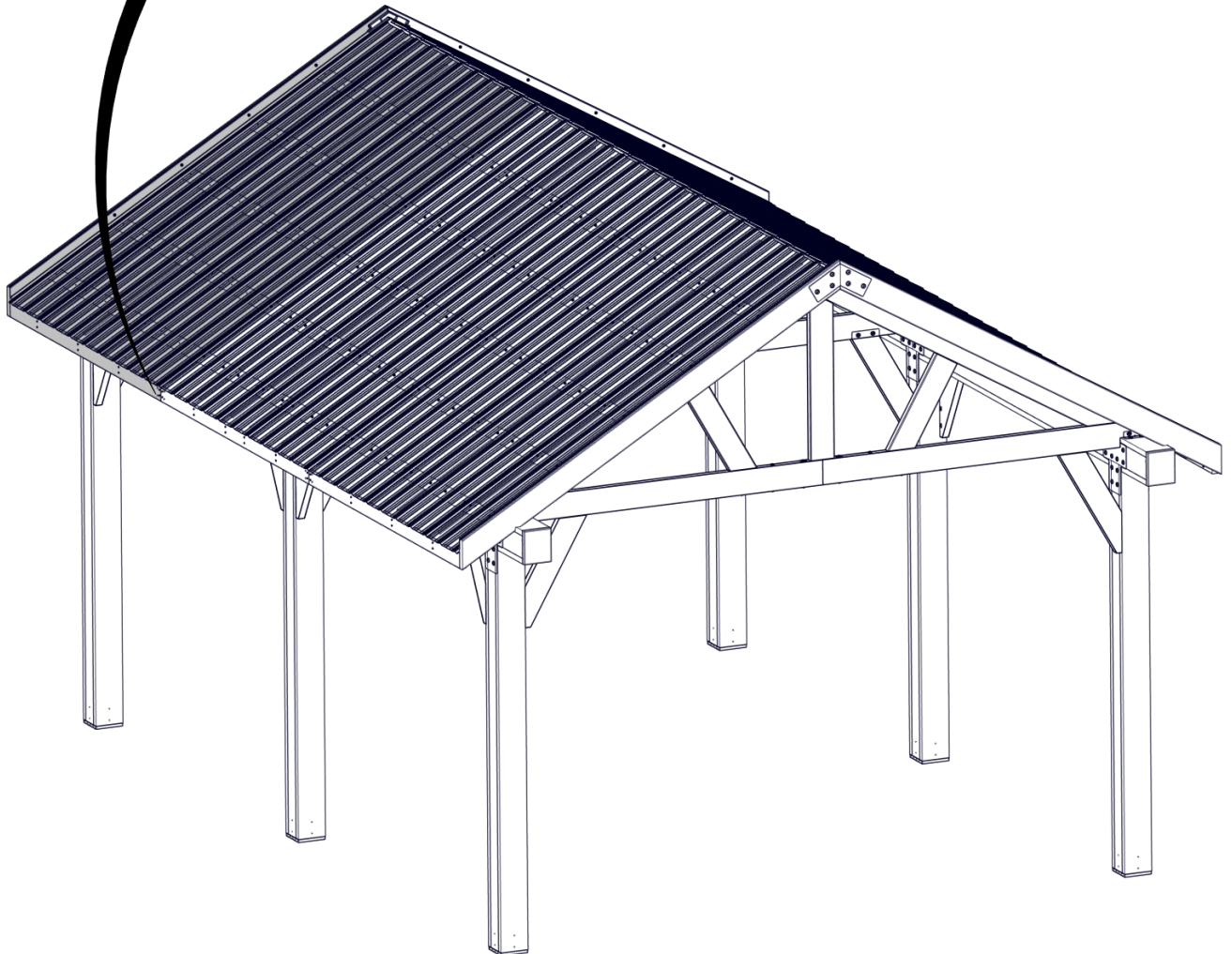

STEP 55 - ROOF ASSEMBLY

QTY	PART NUMBER	DESCRIPTION
4	H100198	WASHER LOCK EXT 8x19
4	H100479	NUT LOCK 5/16 BLK
4	H100534	BOLT WH 5/16x4 1/2 BLK
4	H100630	WASHER FLAT 8x19 BLK

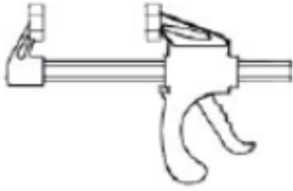

A6P00460 6" QUICK RELEASE CLAMP

- HAND TIGHTEN HARDWARE.

- ADDITIONAL PEOPLE ARE HELPFUL FOR THIS STEP.
- SLIDE ROOF PANEL ALONG GABLE BEAM.
- ALIGN HOLES AND ATTACH HARDWARE AS SHOWN.
- USE A6P00460 QUICK RELEASE CLAMPS IF NEEDED.

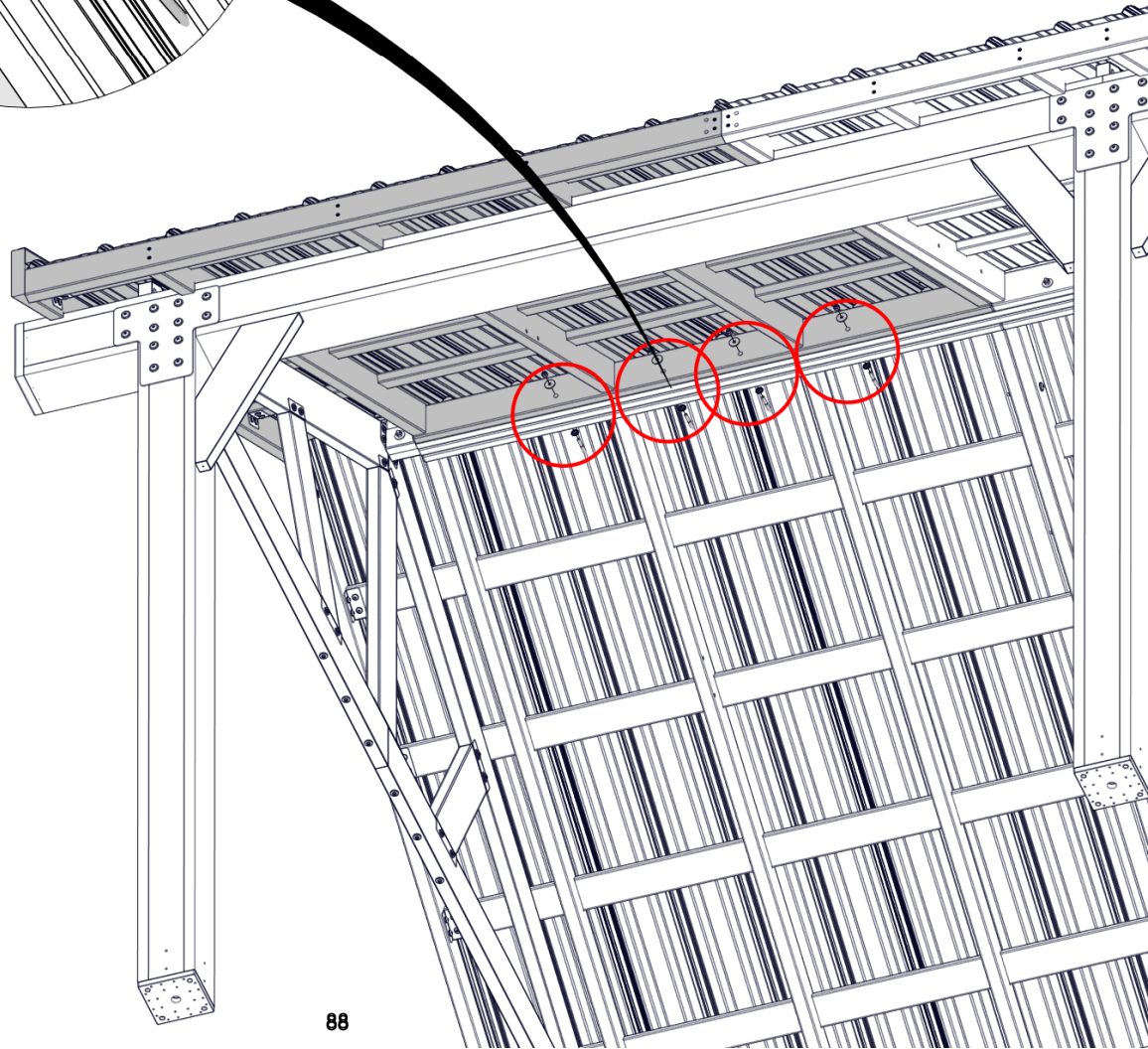
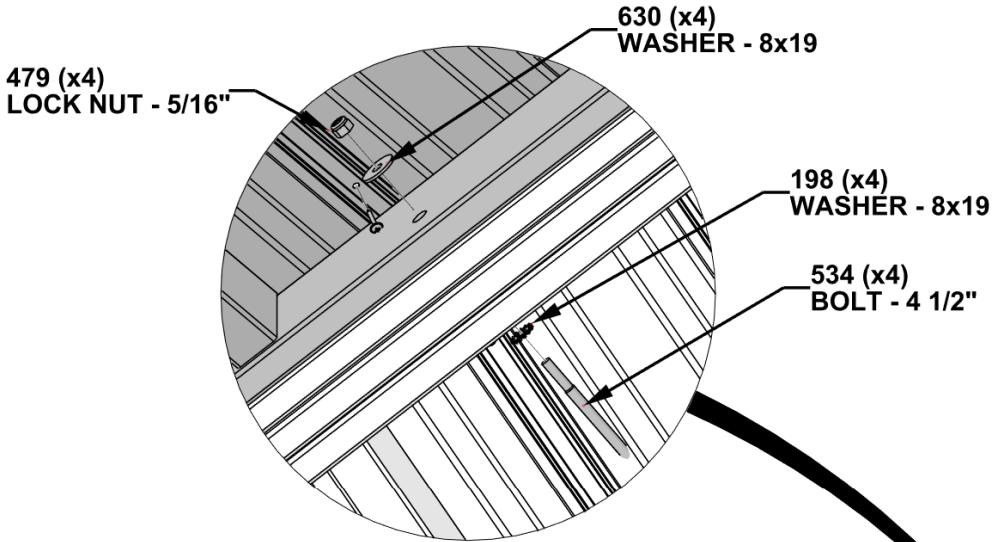
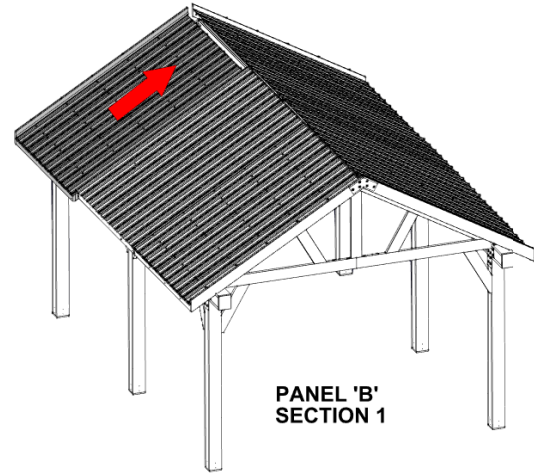

STEP 56 - ROOF ASSEMBLY

QTY	PART NUMBER	DESCRIPTION
6	H100198	WASHER LOCK EXT 8x19
6	H100478	WASHER FLAT 8x27 BLK
6	H100479	NUT LOCK 5/16 BLK
6	H100503	BOLT WH 5/16x3 1/2 BLK

- HAND TIGHTEN HARDWARE.

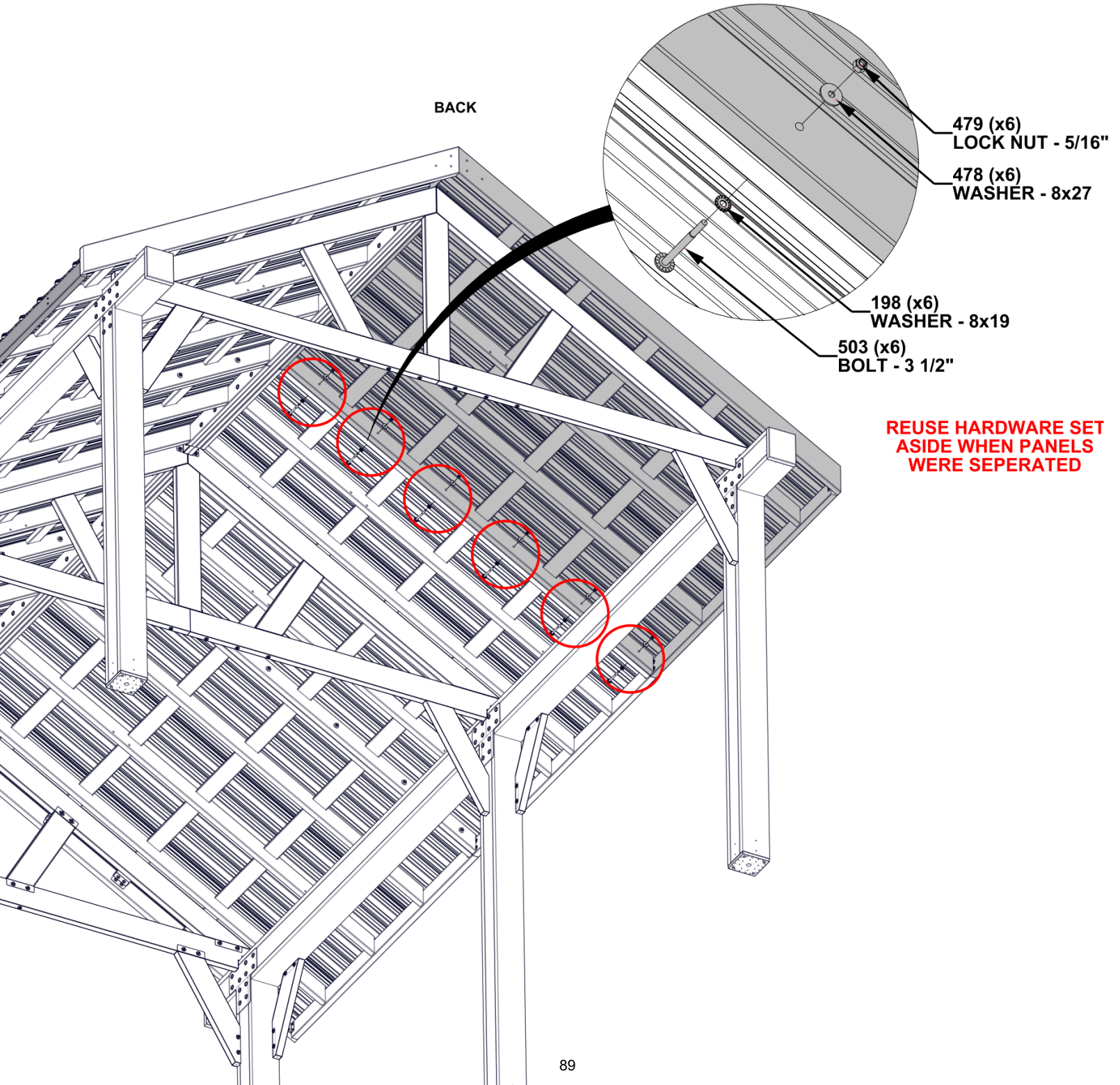

STEP 57 - ROOF ASSEMBLY

QTY	PART NUMBER	DESCRIPTION
20	H100392	SCREW PWH 8x3/4 BLK

DO NOT CLIMB ON ROOF TO INSTALL. RIDGE CAP HAS BEEN DESIGNED TO INSTALL WITH THE USE OF A LADDER.

- FOR PROPER INSTALLATION, USE AN ADULT HELPER TO KEEP DOWNWARD PRESSURE ON THE RIDGE CAP WHILE SCREWING IN SCREWS.

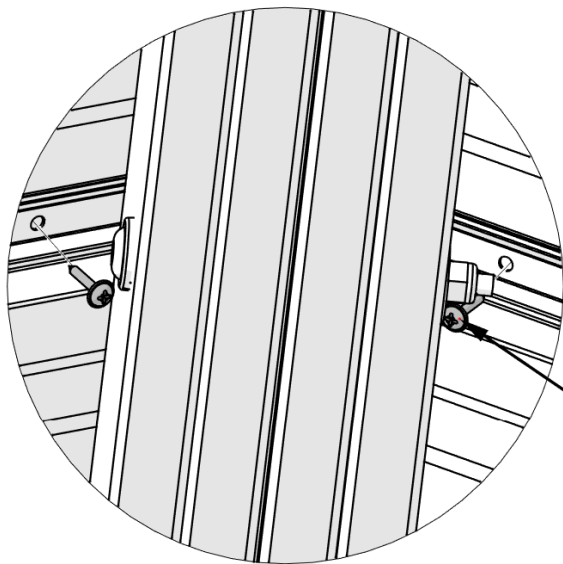

INSTALL SCREWS THROUGH PILOT HOLES IN ROOF PANELS INTO RIDGE CAP STIFFENER BOARDS USING THE H101114 RIGHT ANGLE DRILL ADAPTER ATTACHMENT INCLUDED

392 (x20)
SCREW - 3/4"

BACK

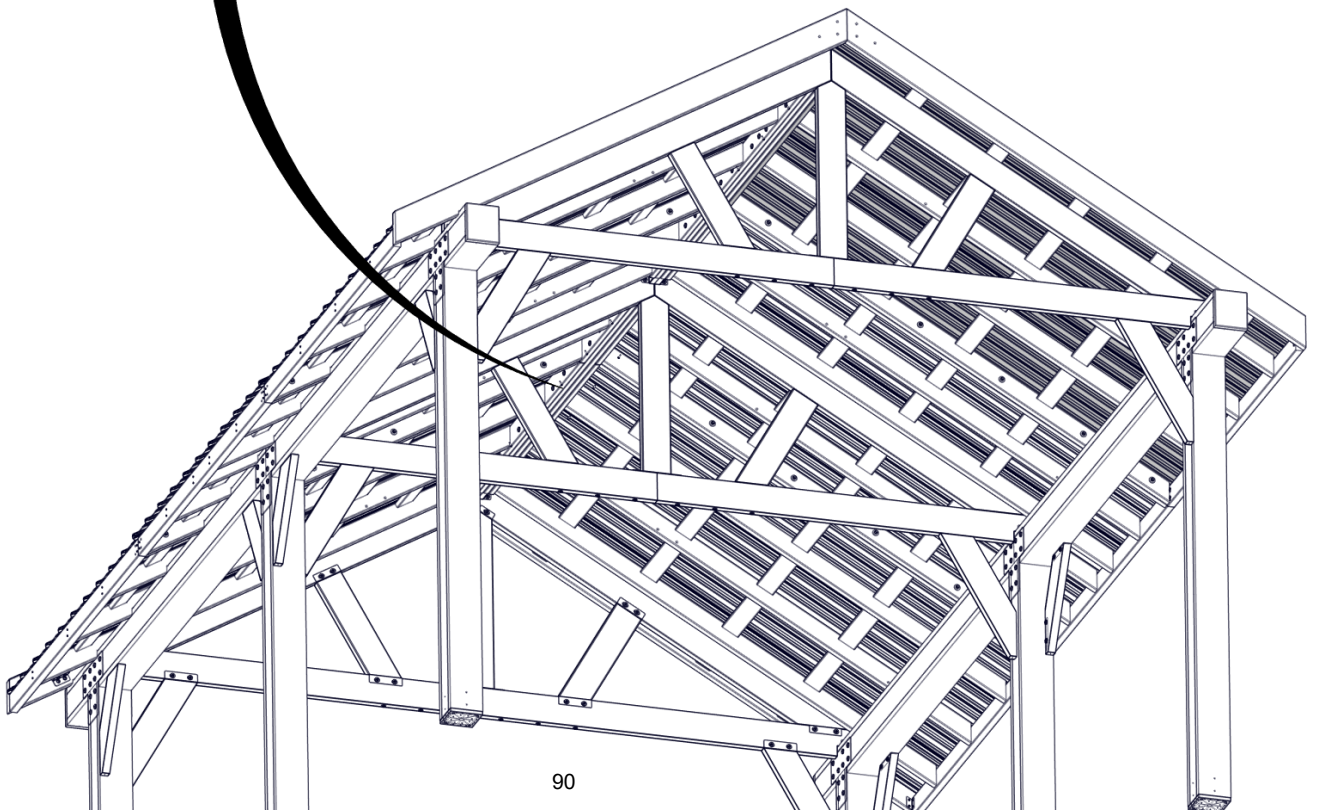

STEP 58 - ROOF ASSEMBLY

QTY	PART NUMBER	DESCRIPTION
6	H100459	BOLT WH 5/16x1 1/4 BLK

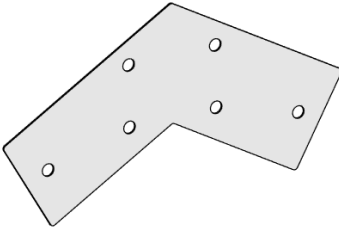

A4M02086 GABLE BRACKET
(x1)

- FASTEN HARDWARE INTO T-NUTS INSTALLED IN D01 AND D02 BOARDS.
- HAND TIGHTEN HARDWARE.
- AFTER HARDWARE HAS BEEN HAND TIGHTENED, FULLY TIGHTEN ALL HARDWARE.

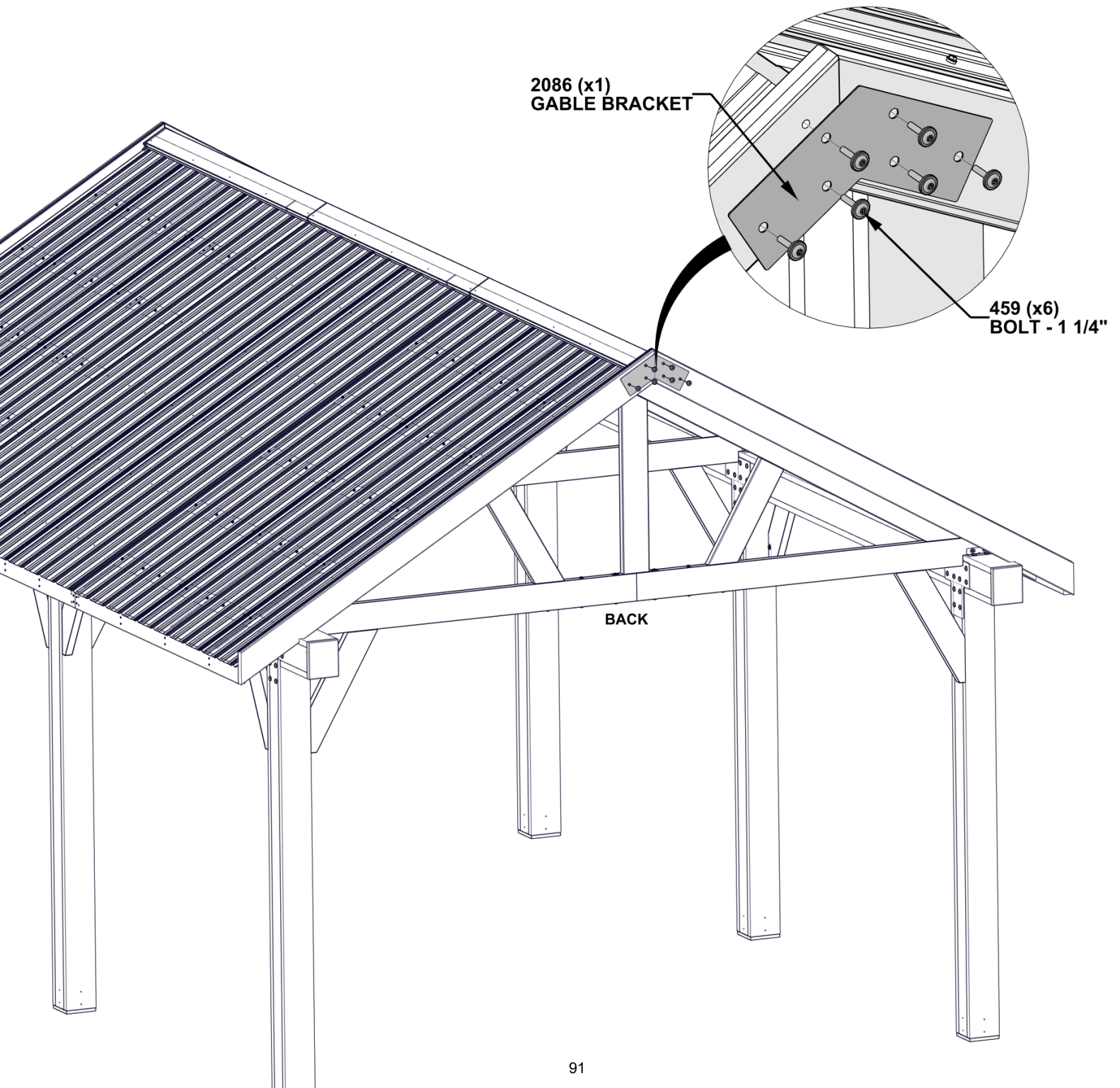

STEP 59 - ROOF ASSEMBLY

QTY	PART NUMBER	DESCRIPTION
16	H100205	BOLT WH 5/16x2 1/4 BLK
16	H100478	WASHER FLAT 8x27 BLK
16	H100479	NUT LOCK 5/16 BLK

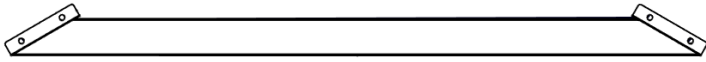

R01 RAFTER SUPPORT BRACE - A4M04329
(x4)

- ALIGN RAFTER SUPPORT BRACE WITH HOLES IN RAFTER BEAMS AS SHOWN.

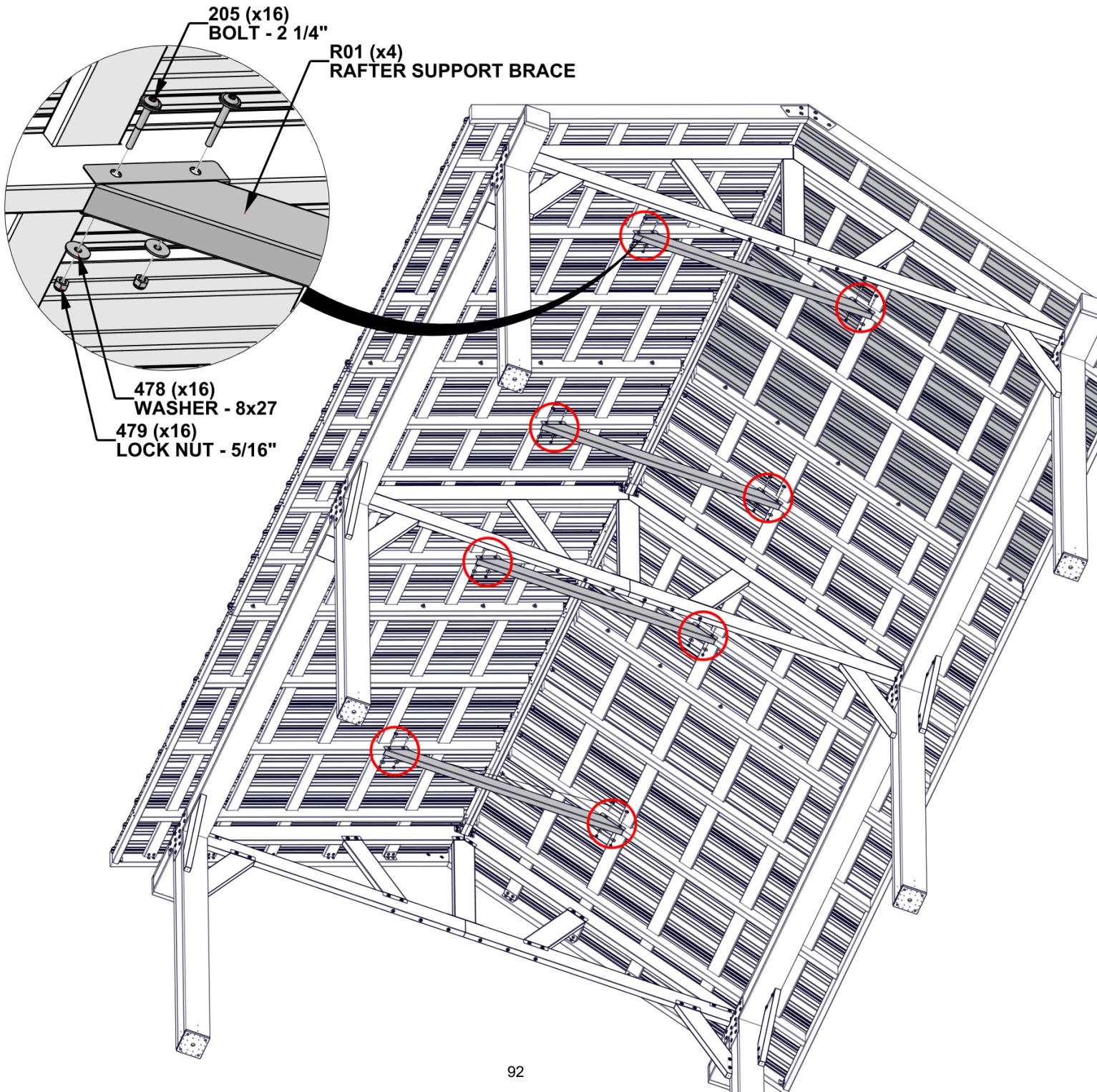

STEP 60 - ROOF ASSEMBLY

QTY	PART NUMBER	DESCRIPTION
8	H100567	BOLT WH 1/4x2 1/4 BLK
8	H100630	WASHER FLAT 8x19 BLK
8	H100653	NUT LOCK 1/4 BLK
24	H100823	SCREW PWH 8x1 1/2 BLK

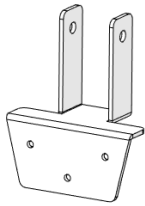

A4M05398 RAFTER CLIP
(x8)

- **HAND TIGHTEN SCREWS THEN FULLY TIGHTEN AFTER ALL HARDWARE HAS BEEN INSTALLED.**
- ALIGN RAFTER CLIPS WITH HOLES IN RAFTERS.
- COMPLETE ON BOTH SIDES.

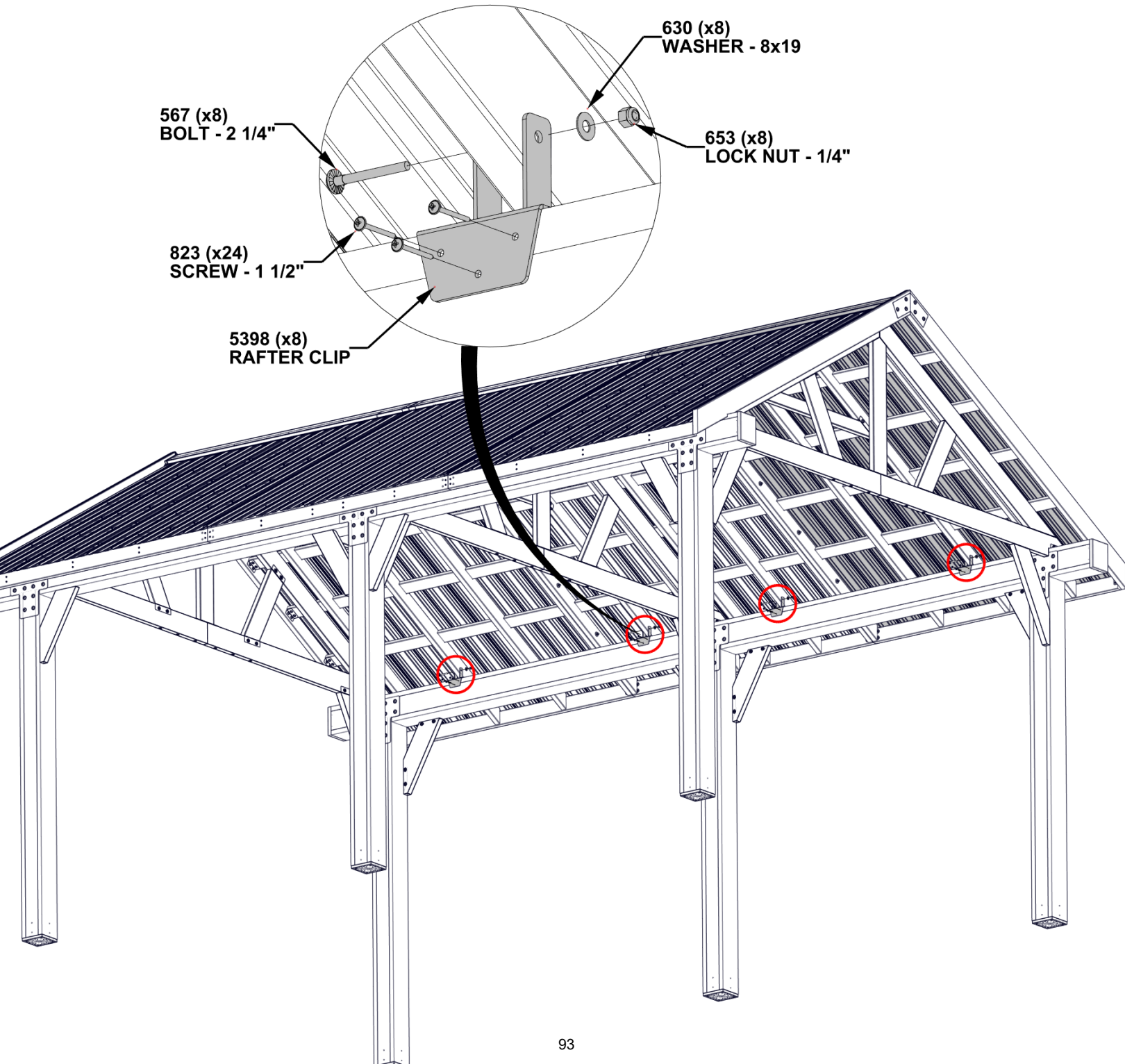

STEP 61 - ROOF ASSEMBLY

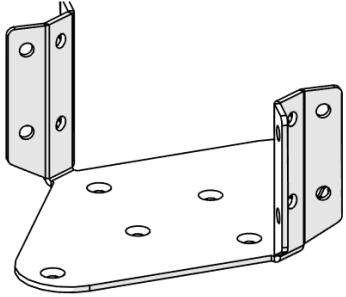

A4M02501 FAN MOUNT BRACKET
(x2)

QTY	PART NUMBER	DESCRIPTION
8	H100391	SCREW PFH 8x2 BLK

- BEFORE MOUNTING, ATTACH YOUR ELECTRICAL BOX (PROVIDED SEPERATELY) USING THE PROVIDED HOLES IN FAN MOUNT BRACKET.
- PLACE FAN MOUNT BRACKET ON RIDGE BEAMS AND MOVE TO DESIRED FAN LOCATION.
- ROTATED BRACKET UNTIL MOUNTING FLANGES ALIGN BEST WITH RIDGE BEAMS.
- USE AN 1/8" [3mm] DRILL BIT AND DRILL PILOT HOLES AND ATTACH AS SHOWN.
- IF BRACKET WILL NOT FIT OVER THE RIDGE BEAM, SLIGHTLY FLEX OUT BRACKET EARS TO FIT.

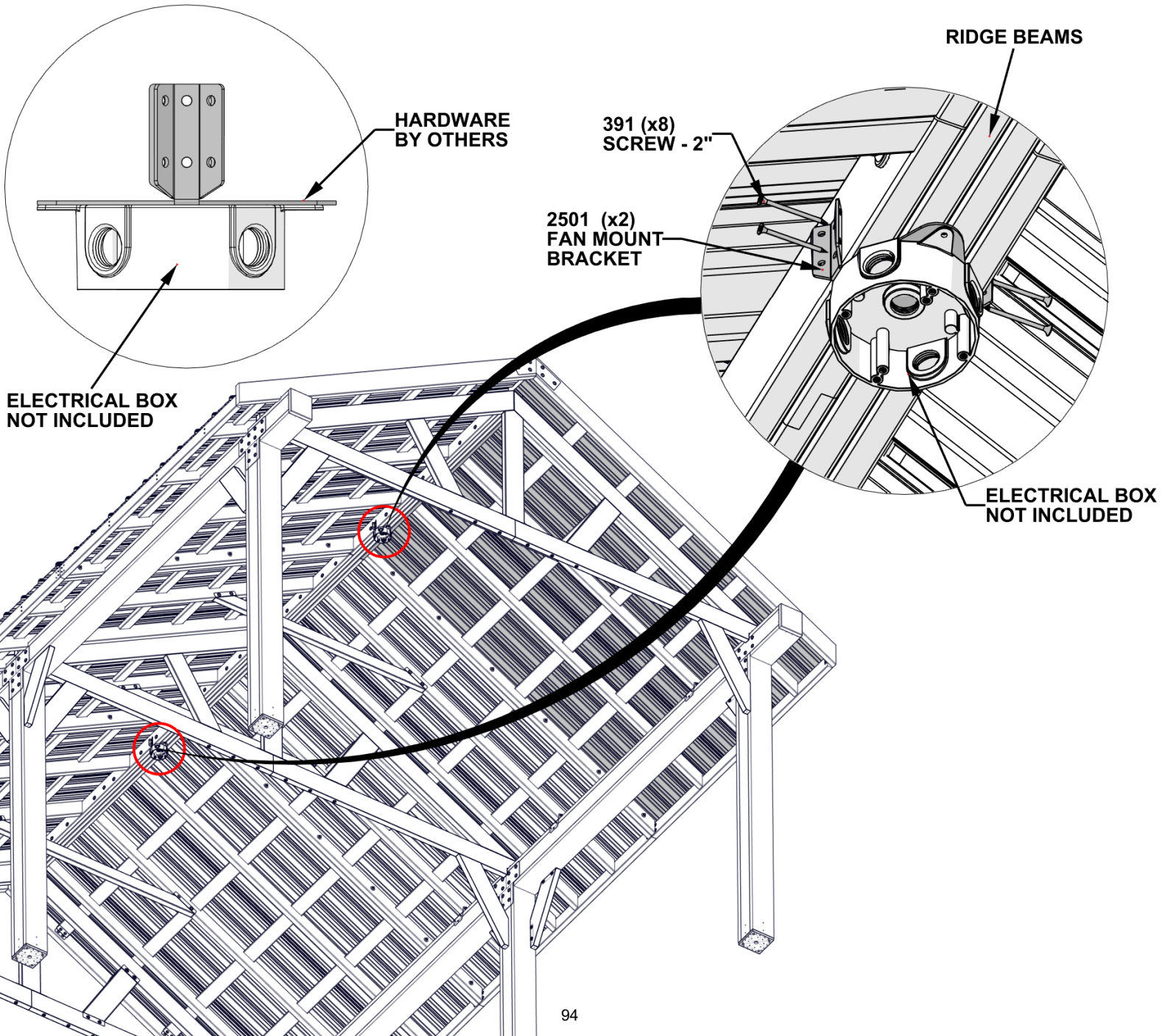

ELECTRICAL BOX
NOT INCLUDED

ELECTRICAL BOX
NOT INCLUDED

STEP 62 - GAZEBO ASSEMBLY

QTY	PART NUMBER	DESCRIPTION
48	H100471	LAG SCREW WH 5/16x1 1/2 BLK

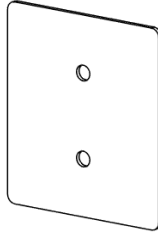
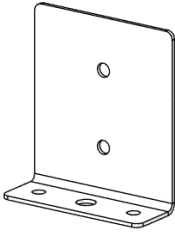

A4M00977 POST ANCHORING PLATE WITH FLANGE
(x12)

A4M00978 POST PLATE
(x12)

- ALIGN POST PLATES WITH PILOT HOLES IN POST.

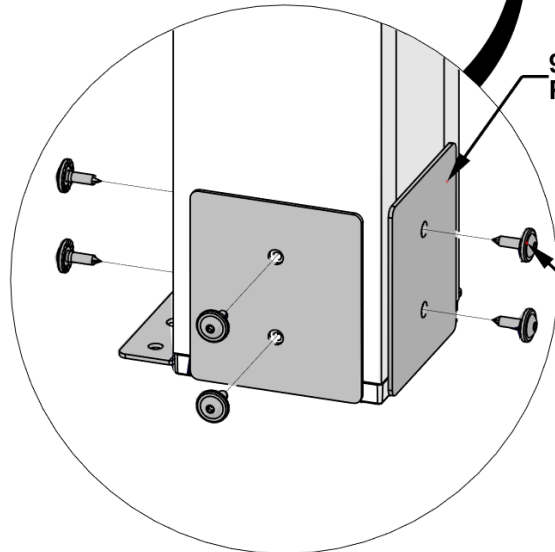
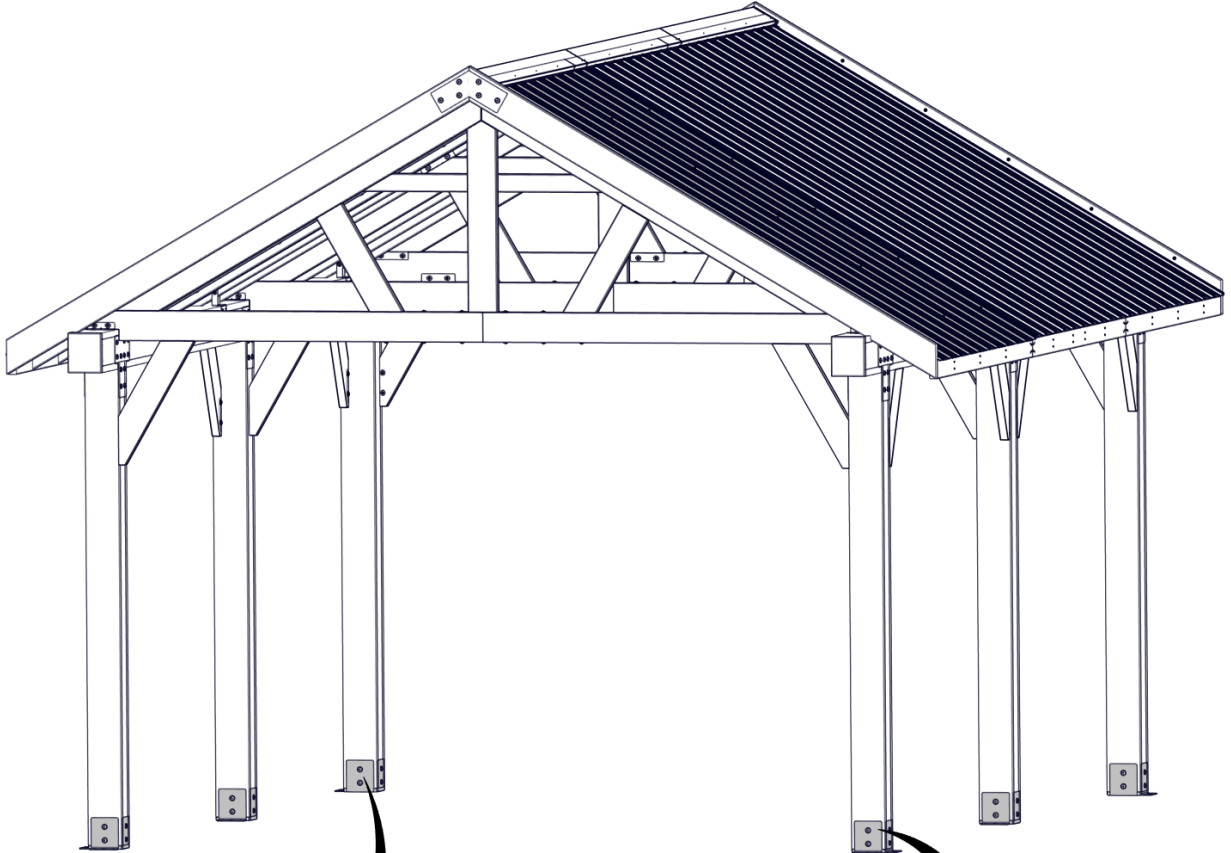

978 (x12)
POST PLATE

471 (x48)
LAG SCREW - 1 1/2"

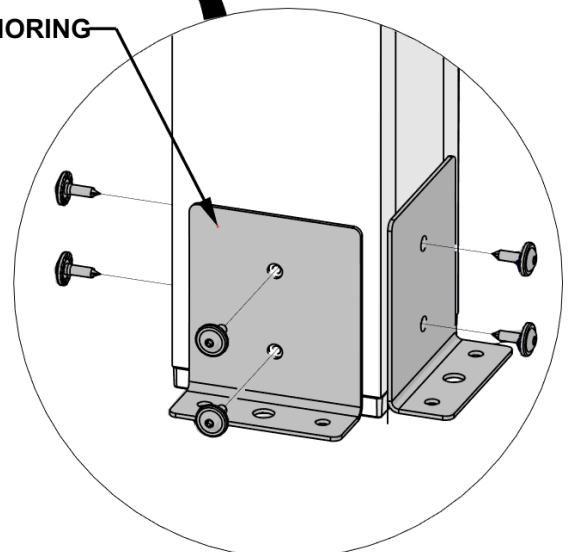

977 (x12)
POST ANCHORING
PLATE

STEP 63 - GAZEBO ASSEMBLY

QTY	PART NUMBER	DESCRIPTION
16	H100407	BOLT WH 5/16x1 1/2 BLK

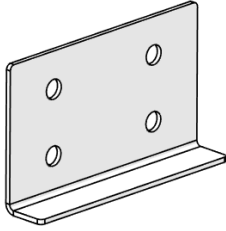

A4M01560 OUTSIDE TIE BRACKET
(x4)

- ALIGN OUTSIDE TIE BRACKET WITH PILOT HOLES IN TRIM BOARDS ON BOTH SIDES.
- ATTACH USING HARDWARE INTO T-NUTS INSTALLED IN PREVIOUS STEPS.
- NOTE ORIENTATION OF 560 OUTSIDE TIE BRACKET.
- COMPLETE ON BOTH SIDES.

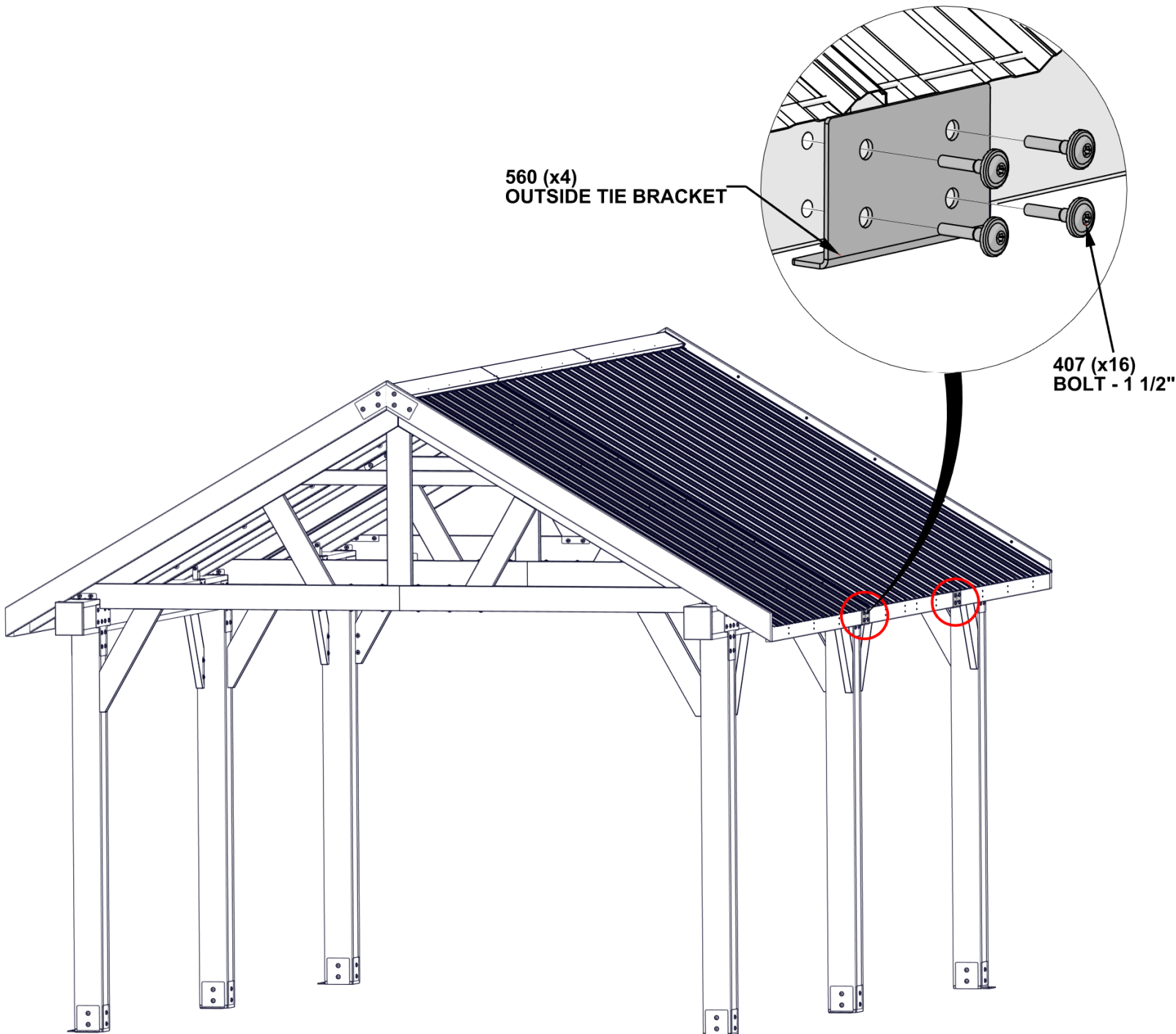

STEP 64 - GAZEBO ASSEMBLY

QTY	PART NUMBER	DESCRIPTION
24	H101165	CONCRETE ANCHOR 3/8x3" BLK

- MANUFACTURER RECOMMENDS INSTALLATION ON CONCRETE SURFACES OR CONCRETE POST PAD AS SHOWN BELOW.
- FOR INSTALLATION ON WOOD DECK, YOU MUST ENSURE THERE IS AMPLE STRUCTURAL SUPPORT UNDER THE DECK.
- HARDWARE NOT INCLUDED FOR DECK ATTACHMENT.

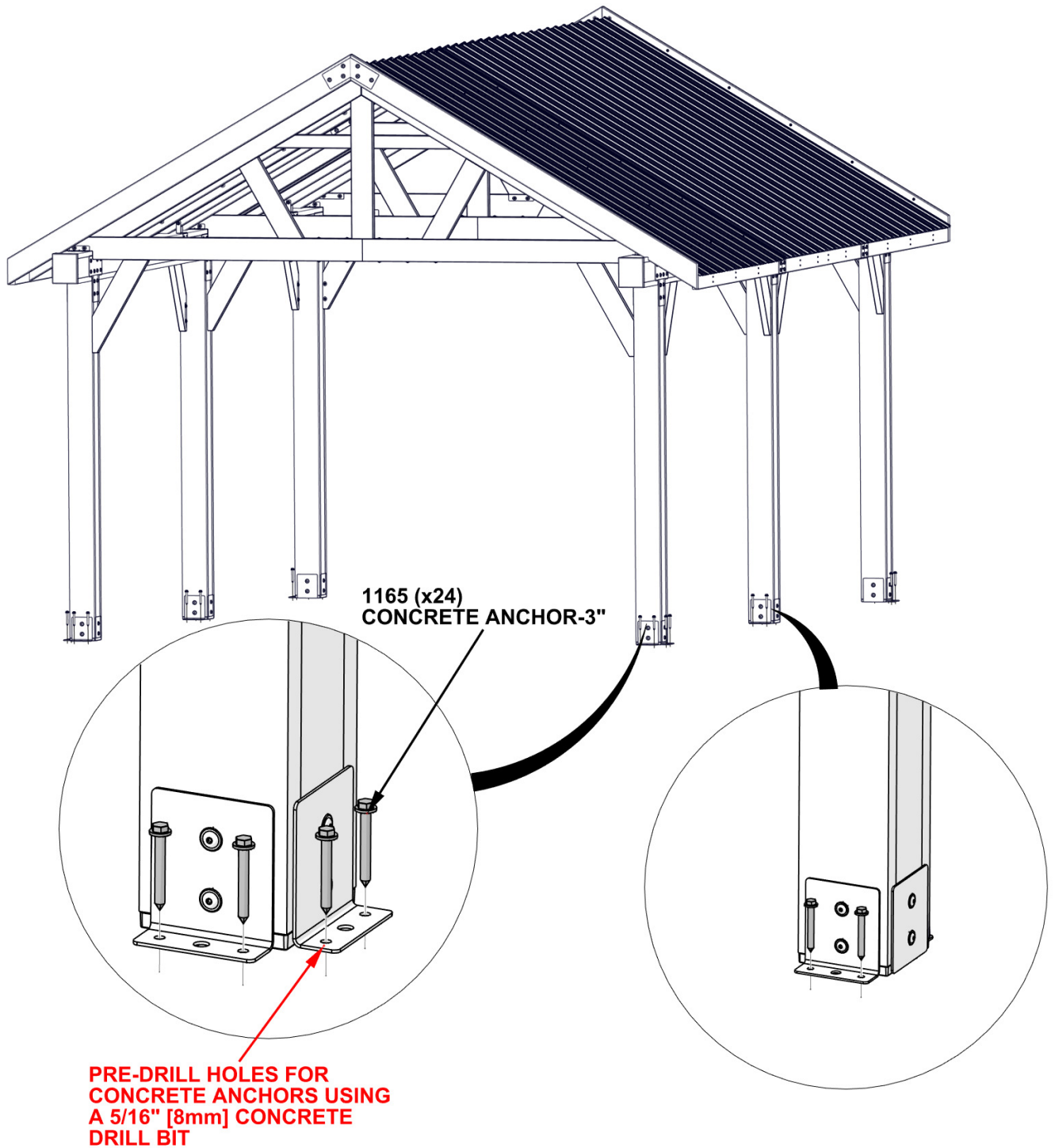

STEP 65 - GAZEBO ASSEMBLY

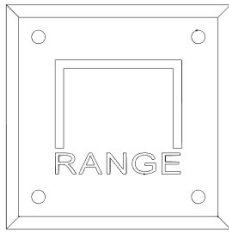

A4M07048 ID TAG RANGE
(x1)

QTY.	PART NUMBER	DESCRIPTION
4	H100202	SCREW PWH 8 X 5/8 BLK

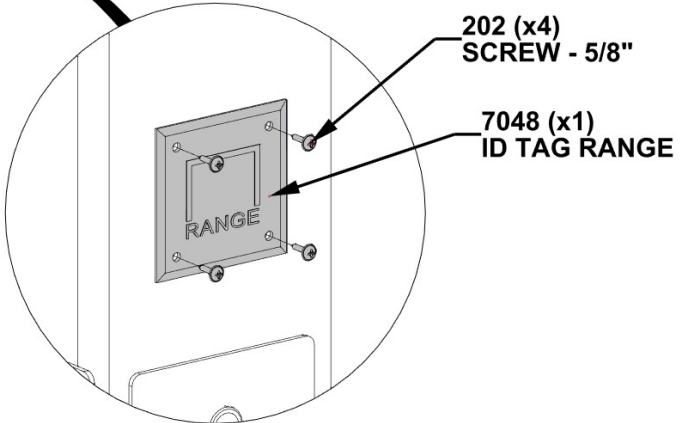
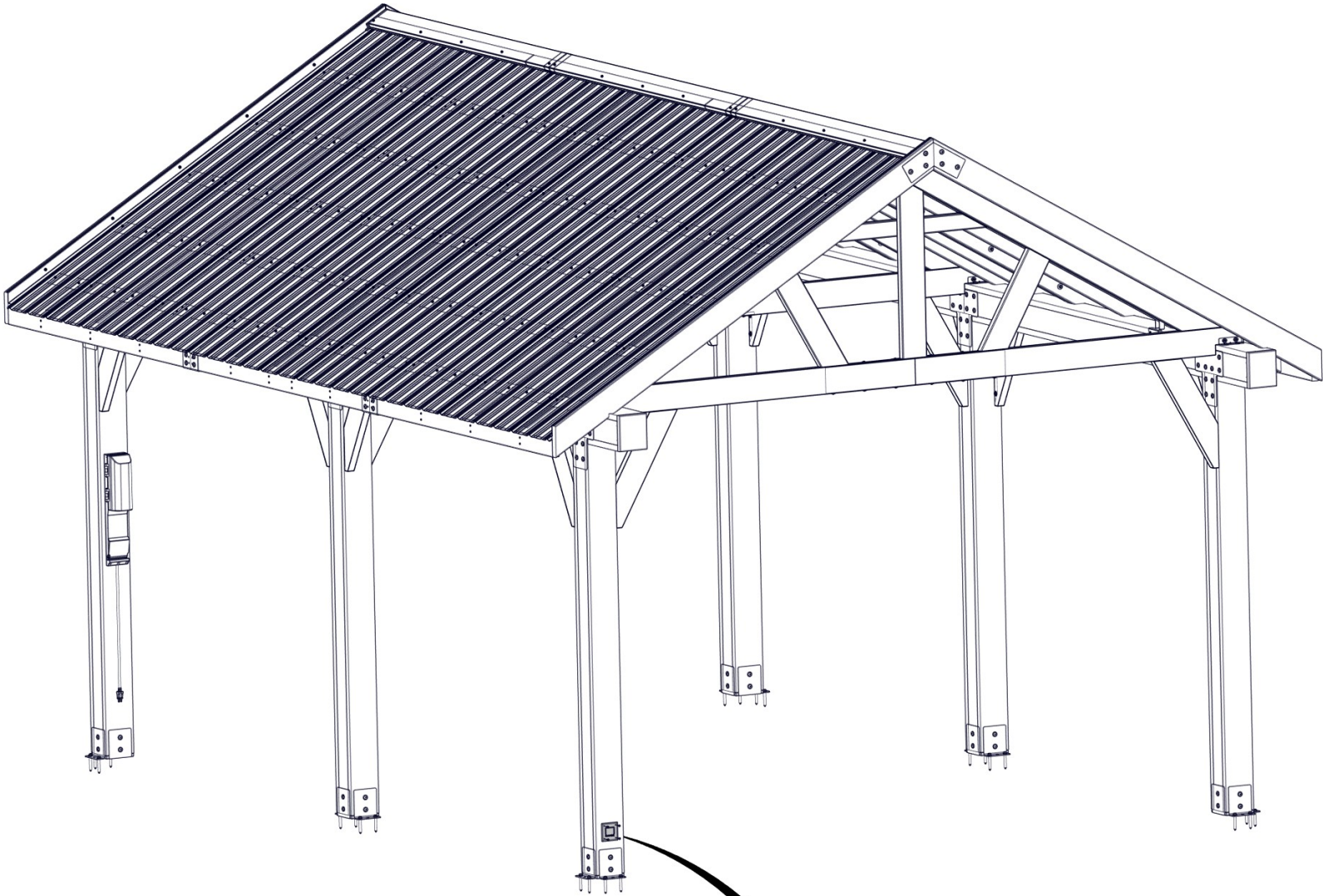

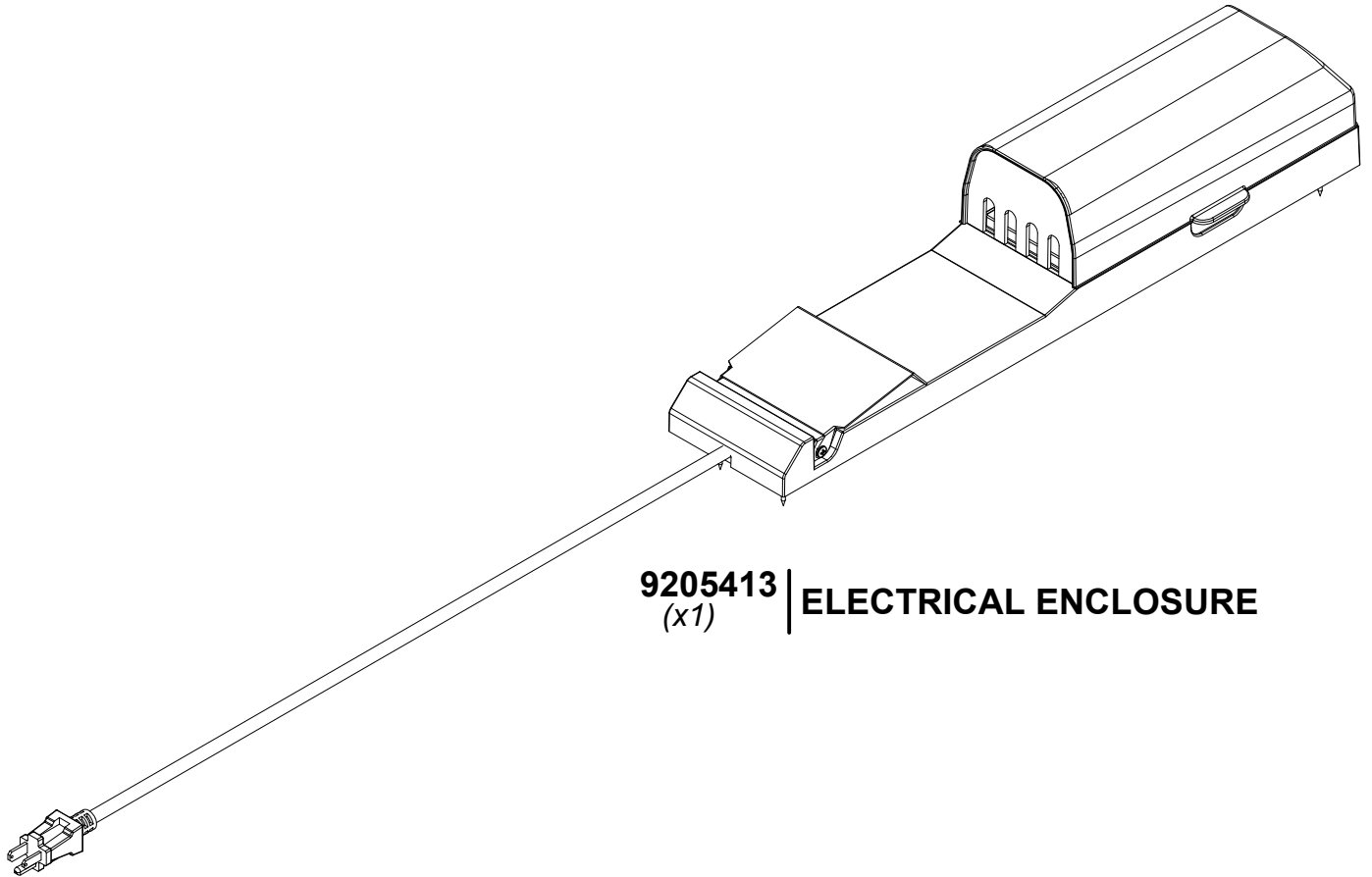

9205413 | **ELECTRICAL ENCLOSURE**
(x1)

FOR POWERPORT INSTALLATION REFER TO ASSEMBLY INSTRUCTIONS THAT COME PACKAGED WITH THE POWERPORT KIT. INSTALL ON ANY POST THAT IS DESIRED. FOLLOW DIRECTIONS FOR PROPER INSTALLATION.