



MANUFACTURED BY:
Backyard Discovery
3305 Airport Drive, Pittsburg, KS 66762
800-856-4445

Basepoint Business Centre: Rivermead Drive, Westlea, Swindon SN5 7EX Phone: 0800-118-2476
J.P. Coenstraat 7, The Bridge, The Hague, 2595 WP, Netherlands Phone: 0800-567-8990

ENDEAVOR

Swing Set

Model # 2200104, 2300033, 2300316



WARNING

Adult Assembly Required.

Not suitable for children under 36 months due to small parts.

FOR DOMESTIC USE ONLY. INTENDED FOR OUTDOOR USE.



Please visit www.backyarddiscovery.com

For the most up to date assembly manual, to register your set, or to order replacement parts

Para obtener instrucciones en español, visite www.backyarddiscovery.com



EASY STEP-BY-STEP
3D INTERACTIVE INSTRUCTIONS

DOWNLOAD THE FREE APP



INSTALLATION
SERVICES
AVAILABLE!

See inside for details

Made in China

INS-2200104, 2300033, & 2300316-A-ENDEAVOR-ENG 05/04/23

Owner's Manual - Basic Setup Dimensions & Assembly Notes

Place the set on level ground, not less than 6'-7" [2 m] from any structure or obstruction such as a fence, garage, house, overhanging branches, laundry lines, or electrical wires.

- While assembling unit, take time before and after each phase to make sure fort is level. If fort is not level, assembly will be difficult and improper assembly may result. Extra care must be taken to insure the fort is square.
- The safe play area refers to a zone extending 6'-7" (2 m) beyond the play product on all sides, including the space above the play product.

SAFE PLAY AREA DIAGRAM

Ground Dimensions

11'-4 1/2" [3.5 m] x 20'-2 1/4" [6.2 m]

Safe Play Area

33'-4 1/4" [10.2 m] x 24'-6 1/4" [7.5 m] x 17'-2 3/4" [5.2 m]

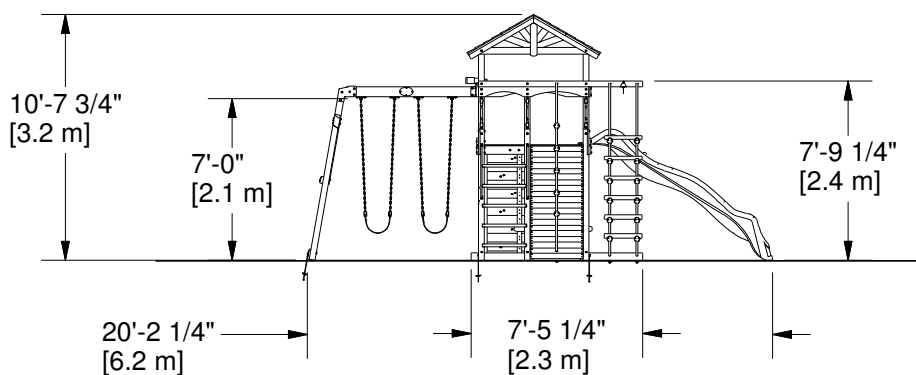
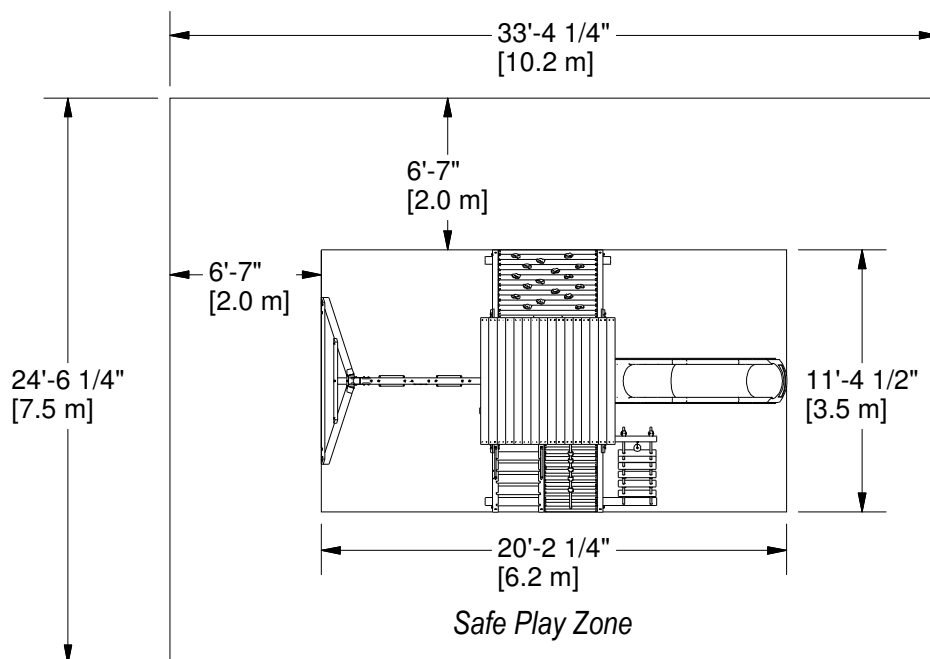

SAFE PLAY HEIGHT: 17'-2 3/4" [5.2 m]
MAXIMUM FALL HEIGHT: 7' [2.1 m]

General Information:

Your set has been designed and engineered for children only and for residential use only.
A maximum of 150 lbs. per child is recommended for play activities designed for individual use.
A maximum of 120 lbs. per child is recommended for play activities designed for multiple child use.
A maximum of 9 children is recommended for this swing set.

Owner's Manual - Parts Identification

Wood Components (Not to Scale)



A50 | SWING BEAM 2 POSITION - W4L15991
(x1) | 3 3/8"x5 1/4"x68 1/2" (86x134x1740)



AL01 | STEP - W4L15737
(x5) | 1 3/8"x4 3/8"x22 3/4" (36x112x579)

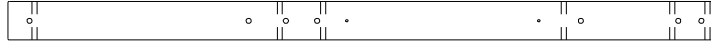

B01 | UPRIGHT - W4L15718
(x2) | 3"x3"x55 1/2" (76x76x1410)



B02 | LEG - W4L15719
(x2) | 3"x3"x77 3/4" (76x76x1975)



B03 | LEG - W2A03278
(x1) | 3"x3"x79 5/16" (76x76x2015)



B04 | UPRIGHT - W4L15722
(x1) | 3"x3"x38" (76x76x964)



B05 | FLOOR JOIST - W4L15723
(x1) | 3"x3"x57 1/4" (76x76x1453)



B06 | UPRIGHT - W4L15728
(x2) | 3"x3"x55 1/2" (76x76x1410)

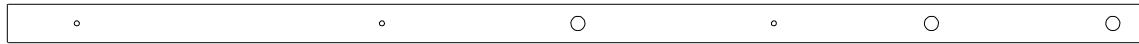

B07 | GROUND BOARD - W4L15733
(x1) | 3"x3"x89 3/8" (76x76x2270)



B08 | LEG - W4L15739
(x1) | 3"x3"x77 3/4" (76x76x1975)



B09 | ROPE BOARD - W4L15740
(x1) | 3"x3"x85 3/8" (76x76x2170)

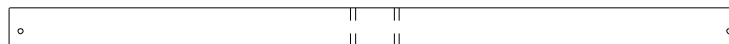

B10 | FLOOR JOIST - W4L15741
(x1) | 3"x3"x57 1/4" (76x76x1453)



B11 | LEG - W4L15747
(x1) | 3"x3"x77 3/4" (76x76x1975)

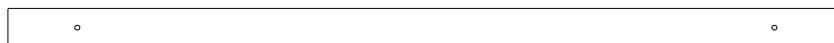

B12 | GROUND BOARD - W4L15976
(x1) | 3"x3"x65 3/8" (76x76x1660)

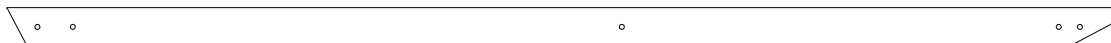

B50 | ANGLE BRACE - W4L15993
(x2) | 3"x3"x87 1/8" (76x76x2212)

Owner's Manual - Parts Identification

Wood Components (Not to Scale)



D01 | WALL RAIL - W4L15729
(x1) | 1 3/8"x5 1/4"x59 1/8" (36x134x1501)

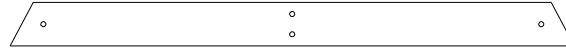

E50 | END SUPPORT - W4L15994
(x1) | 1 3/8"x3 3/8"x44 1/8" (36x86x1120)

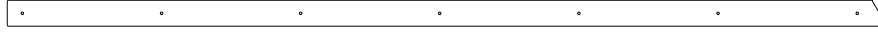

F01 | CLEAT - W4L15746
(x4) | 1 3/8"x2"x68 3/4" (36x52x1747)

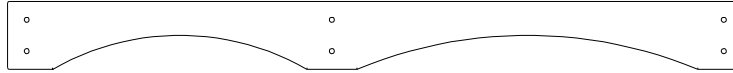

G01 | WALL RAIL - W4L15725
(x1) | 1"x5 1/4"x57 1/2" (24x134x1460)



G02 | WALL RAIL - W4L15726
(x1) | 1"x5 1/4"x59 1/8" (24x134x1501)



G03 | WALL RAIL - W4L15727
(x1) | 1"x5 1/4"x57 1/2" (24x134x1460)



G04 | ROCK WALL BOARD - W4L15749
(x2) | 1"x4 1/2"x51 1/2" (24x115x1307)



G05 | ROCK WALL BOARD - W4L15974
(x5) | 1"x5 1/4"x51 1/2" (24x134x1307)



G06 | ROCK WALL BOARD - W4L15975
(x6) | 1"x5 1/4"x51 1/2" (24x134x1307)



G50 | GROUND BOARD - W4L15995
(x1) | 1"x5 1/4"x86 3/4" (24x134x2202)



H01 | FLOOR RAIL - W4L15734
(x1) | 1"x3 3/8"x68 1/2" (24x86x1741)



H02 | FLOOR RAIL - W4L15735
(x2) | 1"x3 3/8"x22 1/8" (24x86x564)



H03 | FLOOR RAIL - W4L15736
(x6) | 1"x3"x3 3/8" (24x76x86)

Owner's Manual - Parts Identification

Wood Components (Not to Scale)



H04 | ROPE WALL BOARD - W4L15744
(x9) | 1"x3 3/8"x27 5/8" (24x86x701)



H05 | WALL RAIL - W4L15980
(x2) | 1"x3 3/8"x29 7/8" (24x86x760)



H06 | ROPE LADDER RUNG - W4L15982
(x6) | 1"x3 3/8"x19 5/8" (24x86x500)

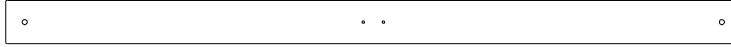

H07 | WALL RAIL - W4L15983
(x2) | 1"x3 3/8"x57 1/2" (24x86x1460)

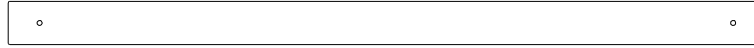

H08 | WALL RAIL - W4L15984
(x2) | 1"x3 3/8"x59 1/8" (24x86x1501)

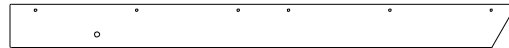

H09 | ROOF RAIL - W4L15985
(x4) | 1"x3 3/8"x39 5/8" (24x86x1007)



H10 | GABLE BOARD - W4L15986
(x2) | 1"x3 3/8"x17 3/8" (24x86x440)



H11 | GABLE CLEAT - W4L15987
(x2) | 1"x3"x3 3/8" (24x76x86)



H12 | GABLE BOARD - W4L15988
(x4) | 1"x3 3/8"x18 1/4" (24x86x465)



H13 | GABLE BOARD - W4L15989
(x4) | 1"x3 3/8"x11 3/4" (24x86x300)

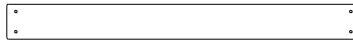

H14 | ROPE WALL BOARD - W4L16119
(x1) | 1"x2 3/4"x27 5/8" (24x69x701)

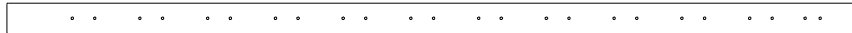

J01 | ROCK WALL CLEAT - W4L15977
(x2) | 1"x2 3/8"x66 7/8" (24x60x1698)



J02 | ROPE WALL CLEAT - W4L16469
(x1) | 1"x2 3/8"x63" (24x60x1600)



K04 | FLOOR BOARD - W4L15978
(x1) | 5/8"x4 3/4"x51 1/2" (16x120x1307)



K05 | FLOOR BOARD - W4L15979
(x1) | 5/8"x4 3/4"x27 5/8" (16x120x701)



M01 | FLOOR BOARD - W4L15743
(x15) | 5/8"x3 3/8"x59 1/2" (16x86x1511)



M02 | ROPE WALL BOARD - W4L15742
(x9) | 5/8"x3 3/8"x27 5/8" (16x86x701)

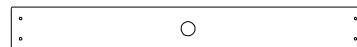

M03 | ROPE WALL BOARD - W4L15981
(x1) | 5/8"x3 3/8"x27 5/8" (16x86x701)



M04 | PICKET - W4L15997
(x10) | 5/8"x3 3/8"x29 7/8" (16x86x760)



N01 | ROOF CLEAT - W4L15990
(x4) | 5/8"x2 3/8"x31 1/2" (16x60x800)

Owner's Manual - Parts Identification

Wood Components (Not to Scale)



O70 | SLIDE MOUNTING BOARD - W4L09040
(x1) | 5/8"x1 3/8"x20 3/8" (16x34x517)



Q01 | FLOOR RAIL - W4L15717
(x2) | 1"x4 3/8"x74 3/8" (24x112x1890)



Q02 | FLOOR RAIL - W4L15721
(x1) | 1"x4 3/8"x57 1/2" (24x112x1460)



Q03 | FLOOR RAIL - W4L15724
(x1) | 1"x4 3/8"x57 1/2" (24x112x1460)



SP01 | SWING BEAM SUPPORT - W4L15992
(x1) | 3 3/8"x3 3/8"x50" (86x86x1269)

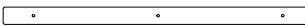

T01 | CLEAT - W4L15748
(x3) | 1"x1 3/8"x24 1/4" (24x34x615)



Y01 | FLOOR BOARD - W4L15738
(x1) | 5/8"x4"x20 7/8" (16x102x529)



Y02 | FLOOR BOARD - W4L15745
(x1) | 5/8"x4"x51 1/2" (16x102x1307)



Y03 | FLOOR BOARD - W4L16468
(x1) | 5/8"x4"x27 5/8" (16x102x701)

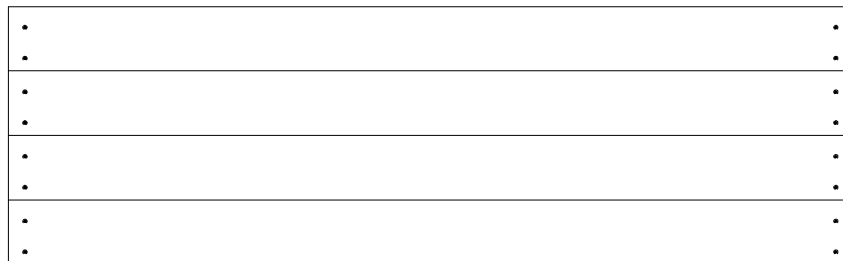

RP1 | ROOF PANEL - W2A03276
(x2) | 1 5/8"x20 5/8"x59" (42x511x1676)

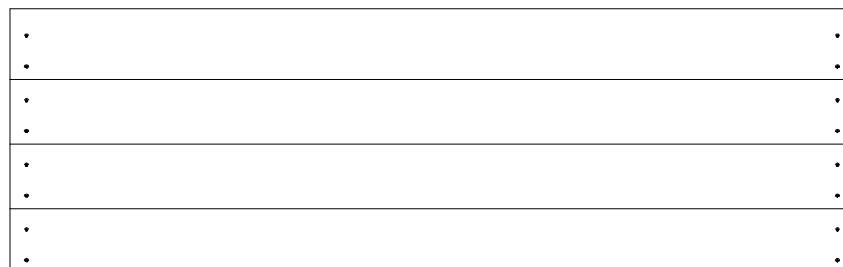

RP2 | ROOF PANEL - W2A03277
(x2) | 1 5/8"x20 5/8"x66" (42x524x1676)

Owner's Manual - Parts Identification

Hardware Components

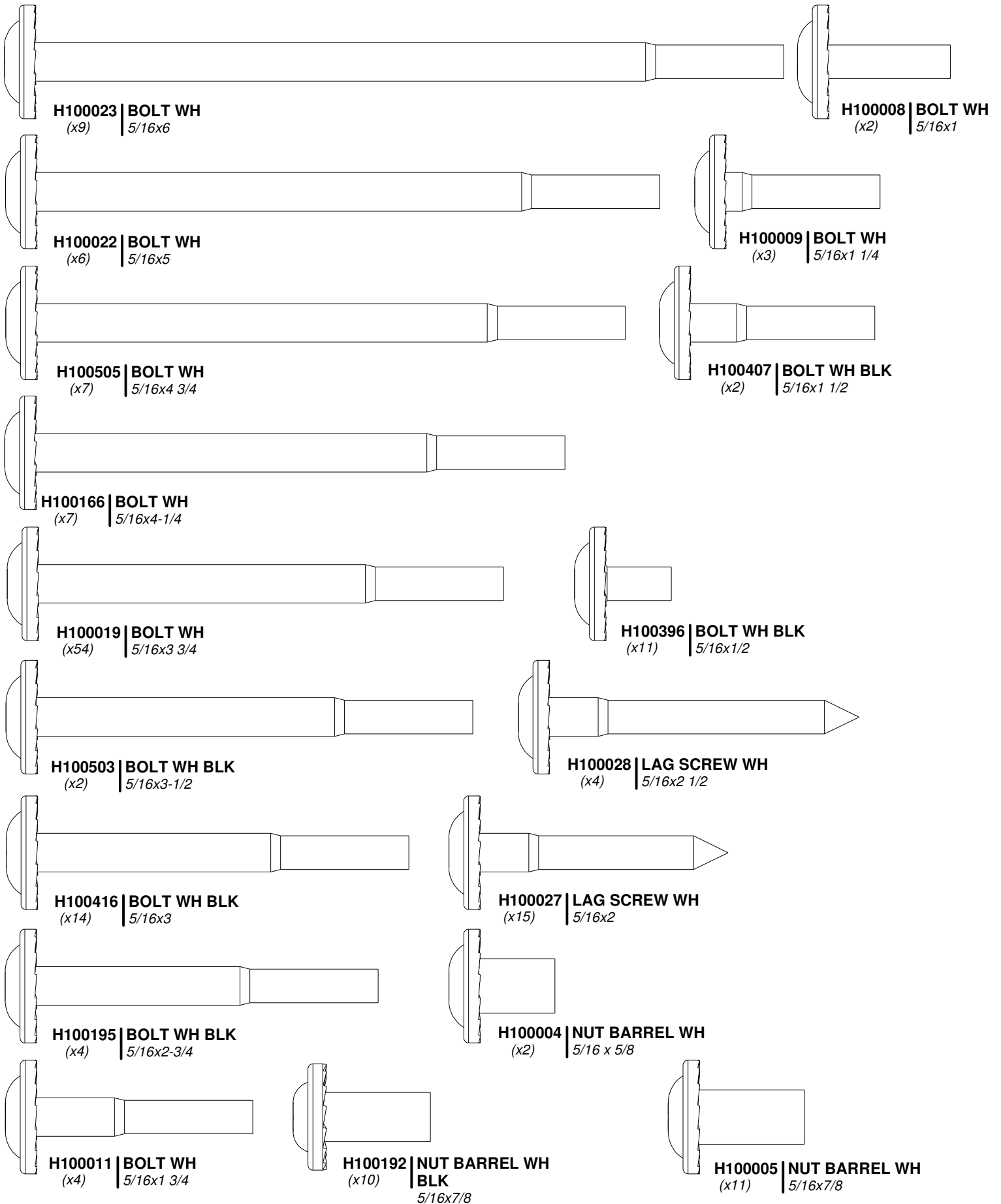

Owner's Manual - Parts Identification

Hardware Components

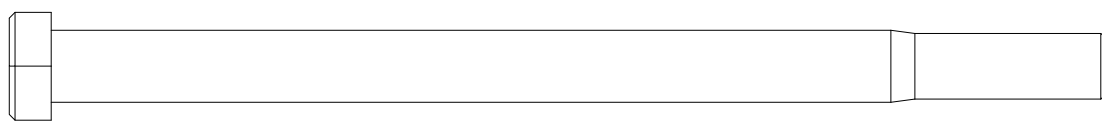

H100654 | BOLT HEX
(x9) | 3/8x5-1/2

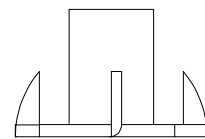

H100073 | T-NUT
(x9) | 3/8

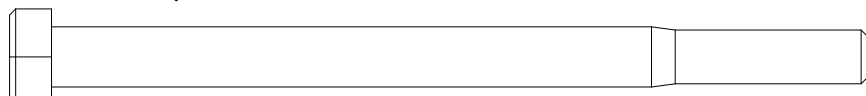

H100476 | BOLT HEX BLK
(x2) | 5/16x4 1/4

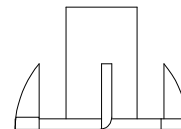

H100074 | T-NUT
(x96) | 5/16

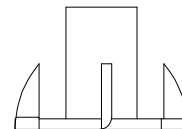

H100379 | T-NUT BLK
(x9) | 5/16



H100050 | BOLT HEX
(x2) | 5/16x3 1/4

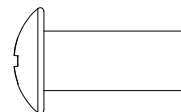

H100831 | NUT BARREL PTH BLK
(x4) | 1/4x3/4

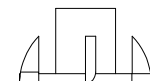

H100072 | T-NUT
(x36) | 1/4



H100498 | BOLT HEX - BLK
(x4) | 5/16x1 1/2

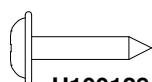

H100128 | SCREW PWH
(x2) | 8x5/8



H100092 | SCREW PFH
(x52) | 8x3

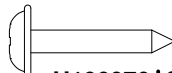

H100070 | SCREW PWH
(x4) | 8x3/4



H100392 | SCREW PWH BLK
(x2) | 8x3/4



H100091 | SCREW PFH
(x39) | 8x2 1/4

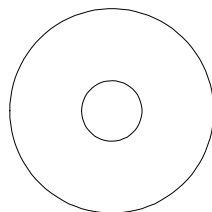

H100105 | WASHER FLAT
(x2) | 8x27

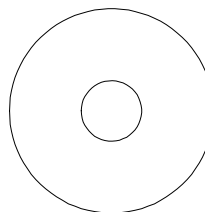

H100478 | WASHER FLAT BLK
(x4) | 8x27

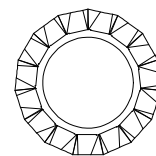

H100031 | WASHER LOCK EXT
(x13) | 12x19

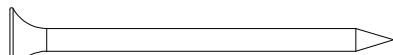

H100111 | SCREW PFH
(x96) | 8x2

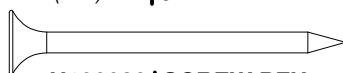

H100089 | SCREW PFH
(x49) | 8x1 3/4

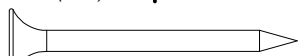

H100086 | SCREW PFH
(x270) | 8x1 1/2

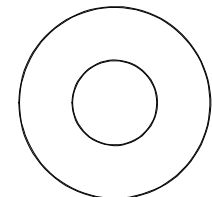

H100102 | WASHER FLAT
(x9) | 11x25

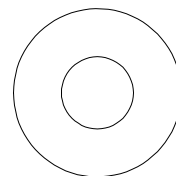

H100770 | WASHER FLAT BLK
(x4) | 5/16

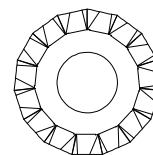

H100030 | WASHER LOCK EXT
(x85) | 8x19

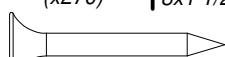

H100380 | SCREW PFH BLK
(x26) | 8x1 1/8

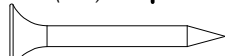

H100088 | SCREW PFH
(x4) | 8x1 1/8

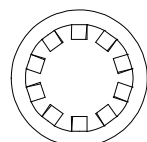

H100107 | WASHER LOCK INT
(x9) | 10x18

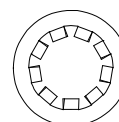

H100108 | WASHER LOCK INT
(x37) | 8x15

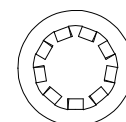

H100473 | WASHER LOCK INT BLK
(x2) | 8x15

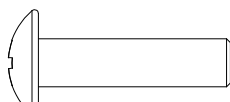

H101121 | BOLT PTH BLK with LOCTITE
(x4) | 1/4x1

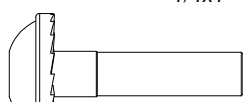

H100137 | BOLT WH
(x36) | 1/4x1

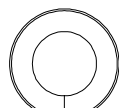

H100477 | WASHER SPLIT BLK
(x4) | 5/16

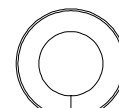

H100095 | WASHER SPLIT
(x2) | 5/16

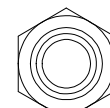

H100479 | NUT LOCK BLK
(x2) | 5/16

Owner's Manual - Parts Identification

Accessory Components (Not to Scale)

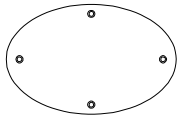

A100164 | BYD ID TAG
(x1) | (LARGE) AGES
3-10

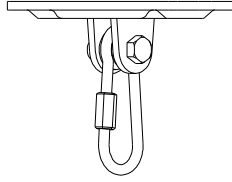

A4M00505 | SWING HANGER
(x4)

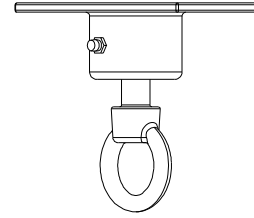

H100338 | SWIVEL ARM
(x1)

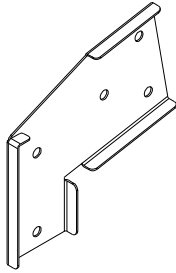

A4M00617 | SWING BEAM
(x1) | EXTENSION
BRACKET-LEFT

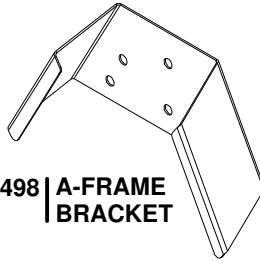

A4M01498 | A-FRAME
(x1) | BRACKET

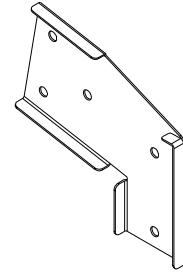

A4M00618 | SWING BEAM
(x1) | EXTENSION
BRACKET-RIGHT

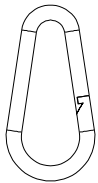

A4M01044 | CARABINER SD
(x1)

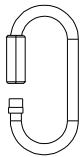

A100069 | QUICK LINK
(x4)

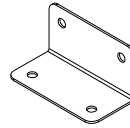

A4M00619 | L BRACKET
(x2) | 66x66x127 - BLK

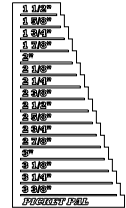

A6P00410 | PICKET PAL
(x1)



A100047 | CHAIN GREEN
(x4) | 57"



A100027 | SWING SEAT
(x2) | GREEN 26"

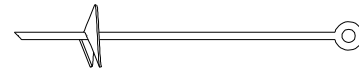

A100178 | AUGER GROUND
(x6) | STAKE

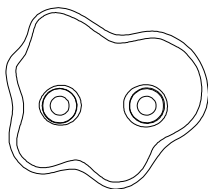

A6P00036 | GREEN HC ROCK
(x9) | #1

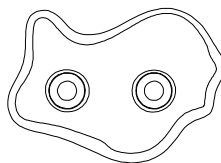

A6P00037 | GREEN HC ROCK
(x8) | #2



A100314 | "A" REVISION
(x1) | TAG

Owner's Manual - Parts Identification

Accessory Components (Not to Scale)

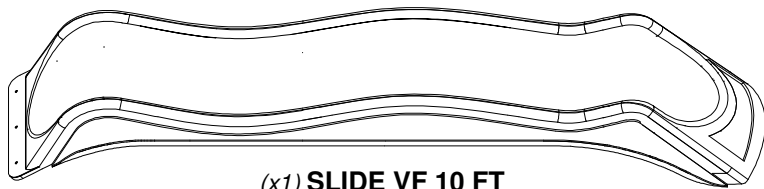

(x1) SLIDE VF 10 FT

10 FT VACUUM FORMED SLIDES		
PART NUMBER	COLOR	MODEL NUMBER
A100287	GREEN	2200104
A6P00540	YELLOW	2300316
A6P00539	GREY	2300033

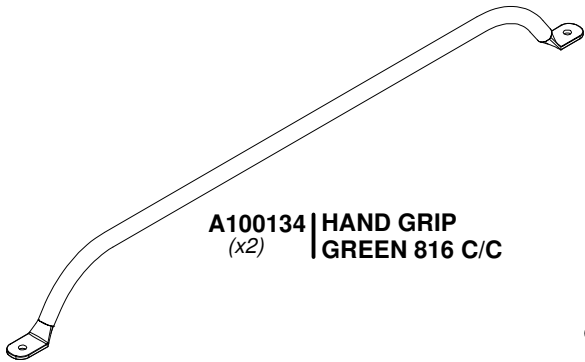

A100134 | HAND GRIP
(x2) | GREEN 816 C/C

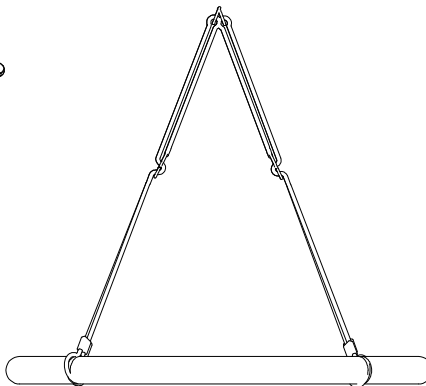

A4M01495 | 40" WEB SWING
(x1)

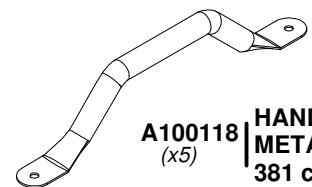

A100118 | HAND GRIP
(x5) | METAL GREEN
381 c/c

A6P00507 | ROPE
(x3)

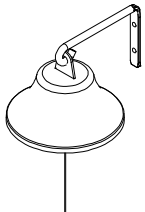

A4M00554 | BELL
(x1)

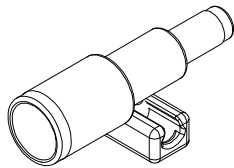

A6P00096 | TELESCOPE
(x1)

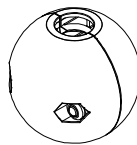

A6P00508 | ROPE CLAMP KIT
(x23)

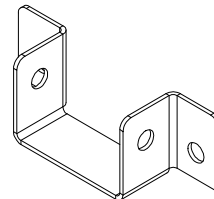

A4M01480 | JOIST HANGER
(x4) | 90°

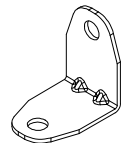

A4M01047 | L BRACKET
(x2) | 2.5x38x55x55

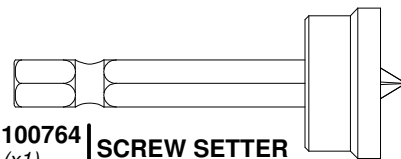

H100764 | SCREW SETTER
(x1)

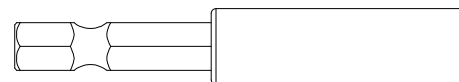

H101100 | MAGNETIC DRIVER
(x1)

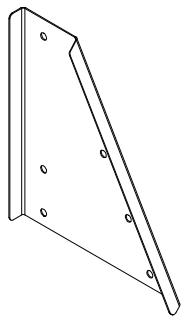

A4M01481 | A-FRAME
(x2) | BRACKET-RT

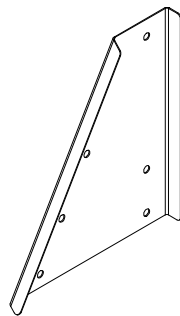

A4M01482 | A-FRAME
(x2) | BRACKET-LT

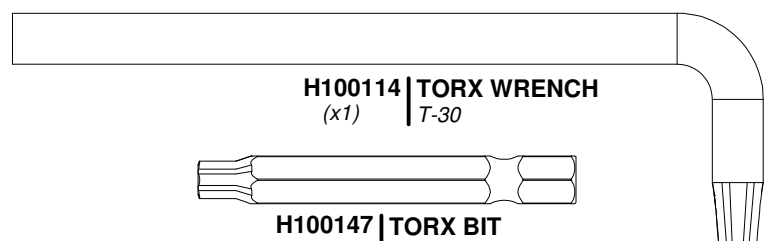

H100114 | TORX WRENCH
(x1) | T-30

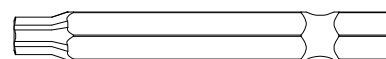

H100147 | TORX BIT
(x1) | T-30

PRE-ASSEMBLY STEP 1 - SORTING PARTS

It is critical for ease of assembly that you take the time to sort and organize the wood and hardware.

WOOD PARTS:

- Organize wood parts by the three-digit, alpha-numeric number stamped on each board (ex. P01).
- If there are multiple boards with the same stamped number, stack those pieces together.
- Stamps can be found on the flat surface of the boards or on the end of the boards.
- Allow yourself plenty of room - the wood pieces can take up a significant amount of space.

NOTE: CARTONS ARE NOT ORGANIZED BY BOARD NUMBER.

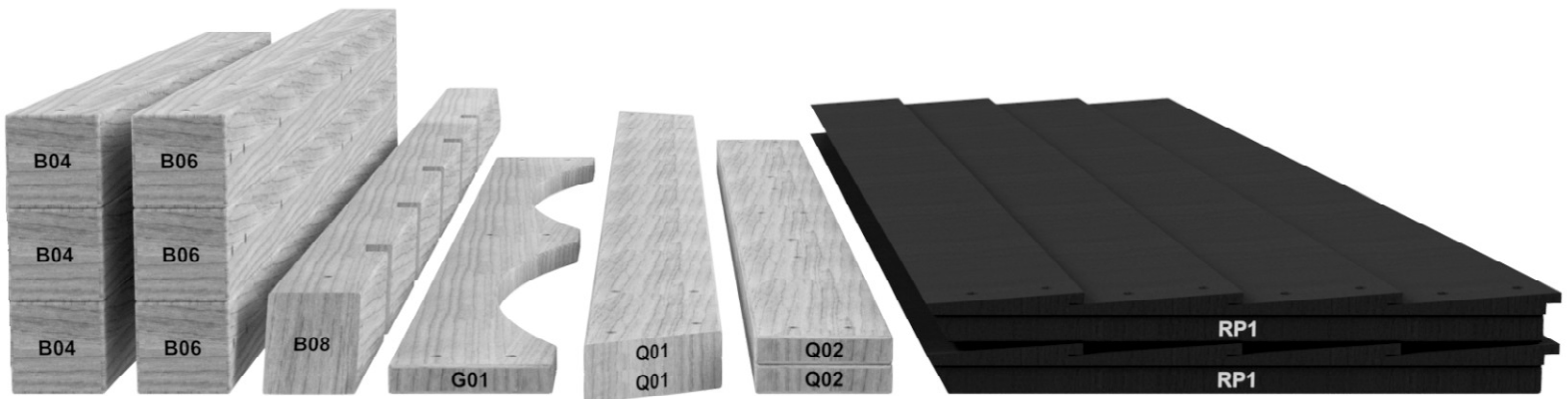

HARDWARE PARTS:

- We recommend that you have a separate table to organize the hardware.
- Hardware bags are printed with a seven-digit, alpha-numeric part number.
- You can organize your hardware by part number or group by hardware type (i.e. bolts, nuts, etc.).
- During assembly you only need to reference the last four digits of the number.

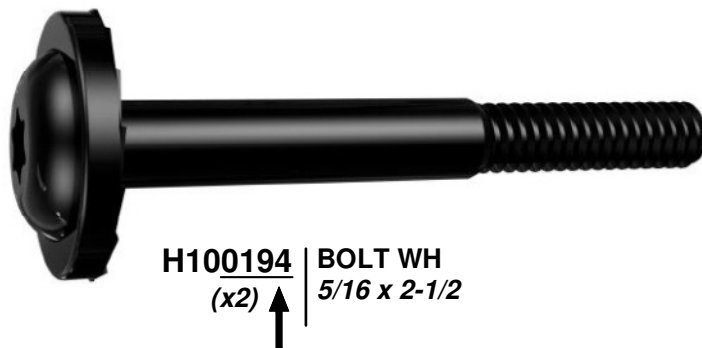

PRE-ASSEMBLY STEP 2 - TOOLS REQUIRED



Cordless Drill or
Electric Drill

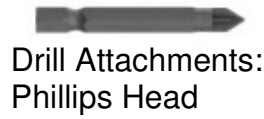

Drill Attachments:
Phillips Head



1/8", 3/16", 3/8" & 7/16"
Drill Bits



Phillips Screw Driver



Open End Wrenches 1/2" & 9/16"



3/8" Drive Ratchet, 1/2" &
9/16" STD Sockets 1/2" & 9/16"
Deep Sockets



Claw Hammer



Rubber Mallet - Optional



Tape Measure

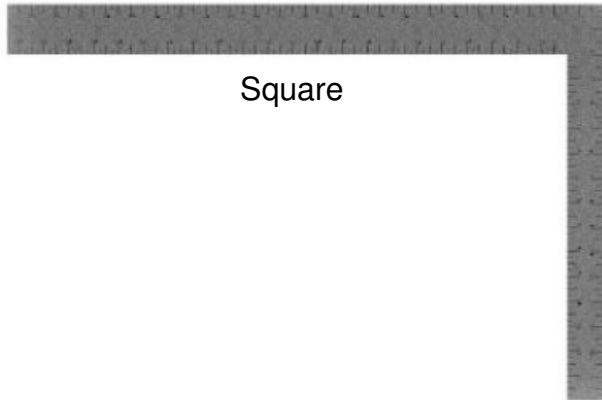

Square





Level 24"

PRE-ASSEMBLY STEP 3 - CHOOSE YOUR ASSEMBLY METHOD



There are several types of assembly instructions available to you.

1. Printed Assembly Manual included with your set
2. BILT APP - 3D interactive instructions
3. Combination of the Printed Manual and BILT APP (Note: Step numbers can differ between the two methods)

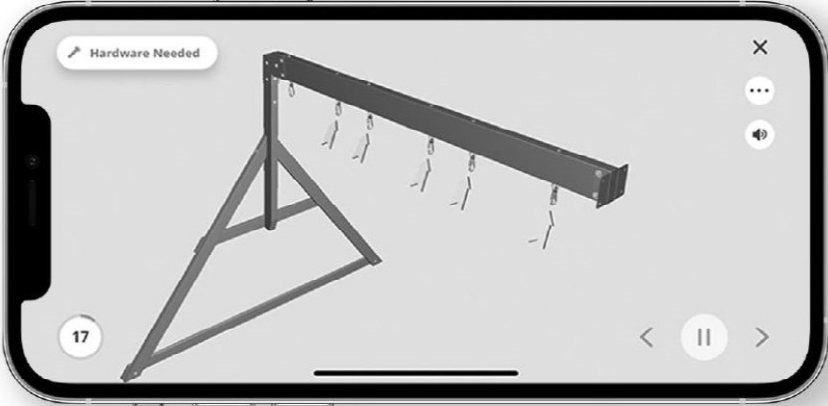

Scan for easy 3D instructions

Download the BILT app
before you begin



The image shows a smartphone screen displaying the BILT app interface. The screen features a 3D assembly diagram of a structure with a horizontal beam and a triangular support. The interface includes a 'Hardware Needed' button at the top left, a close button (X) at the top right, a menu button (three dots) and a volume icon below it, and a page number '17' in a circle at the bottom left. At the bottom center, there are navigation arrows and a pause button.

STEP 1 - SWING BEAM ASSEMBLY

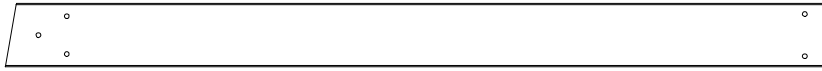

A50 | SWING BEAM 2 POSITION - W4L15991
(x1) | 3 3/8"x5 1/4"x68 1/2" (86x134x1740)

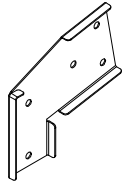

A4M00617 | SWING BEAM
EXTENSION
BRACKET-LEFT
(x1)

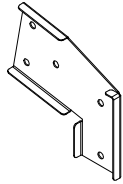

A4M00618 | SWING BEAM
EXTENSION
BRACKET-RIGHT
(x1)



A4M00619 | L BRACKET
(x2) | 66x66x127 - BLK

QTY	PART NUMBER	DESCRIPTION
3	H100192	NUT BARREL WH 5/16x7/8 BLK
3	H100416	BOLT WH 5/16x3 BLK
2	H100473	WASHER LOCK INT 8x15 BLK
2	H100476	BOLT HEX 5/16x4 1/4 BLK
2	H100479	NUT LOCK 5/16 BLK
4	H100770	WASHER FLAT 5/16 BLK

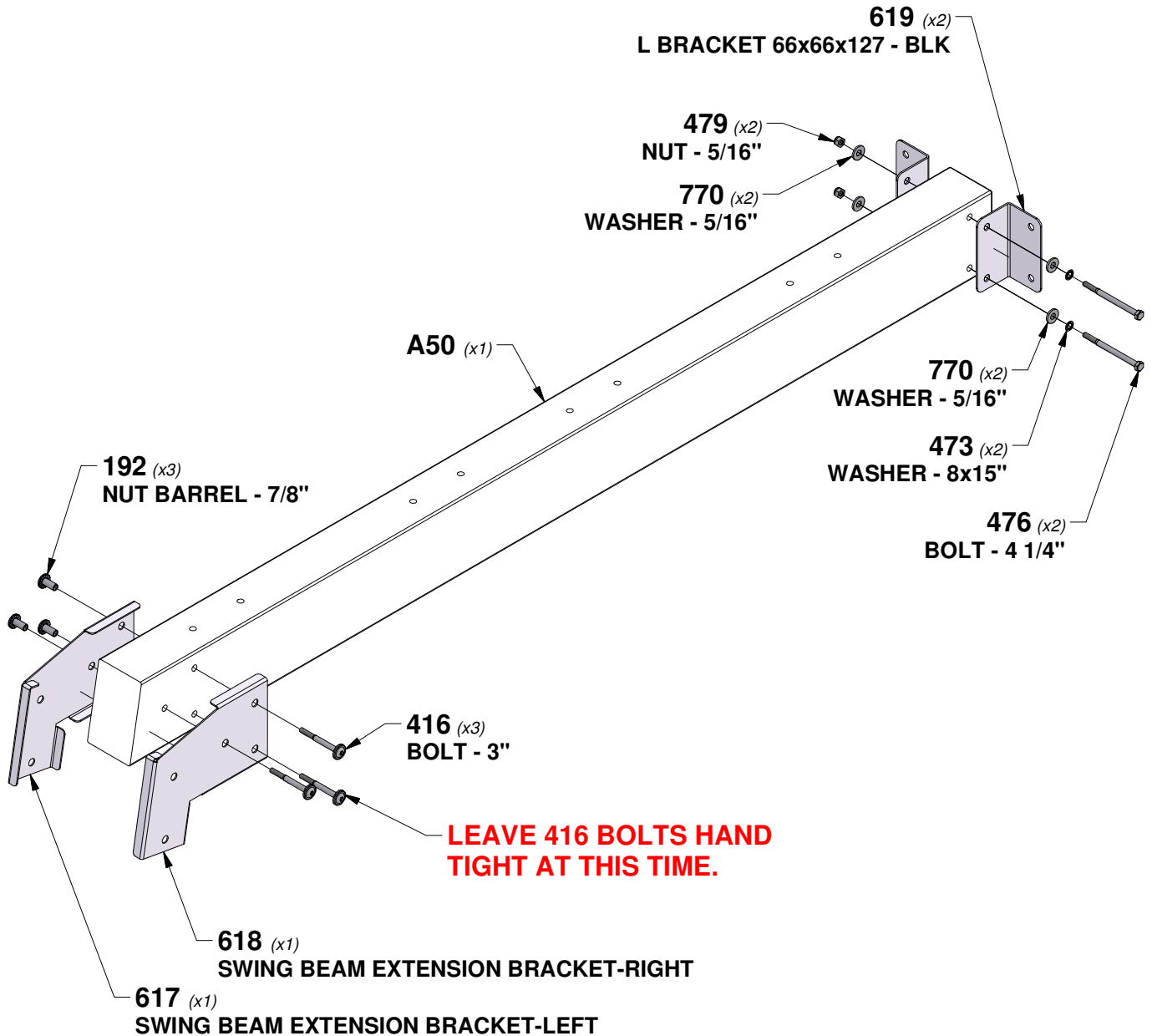

STEP 2 - SWING BEAM ASSEMBLY

QTY	PART NUMBER	DESCRIPTION
8	H100073	T-NUT 3/8
8	H100102	WASHER FLAT 11x25
8	H100107	WASHER LOCK INT 10x18
8	H100654	BOLT HEX 3/8x5-1/2

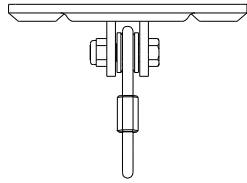

A4M00505
(x4) | SWING HANGER

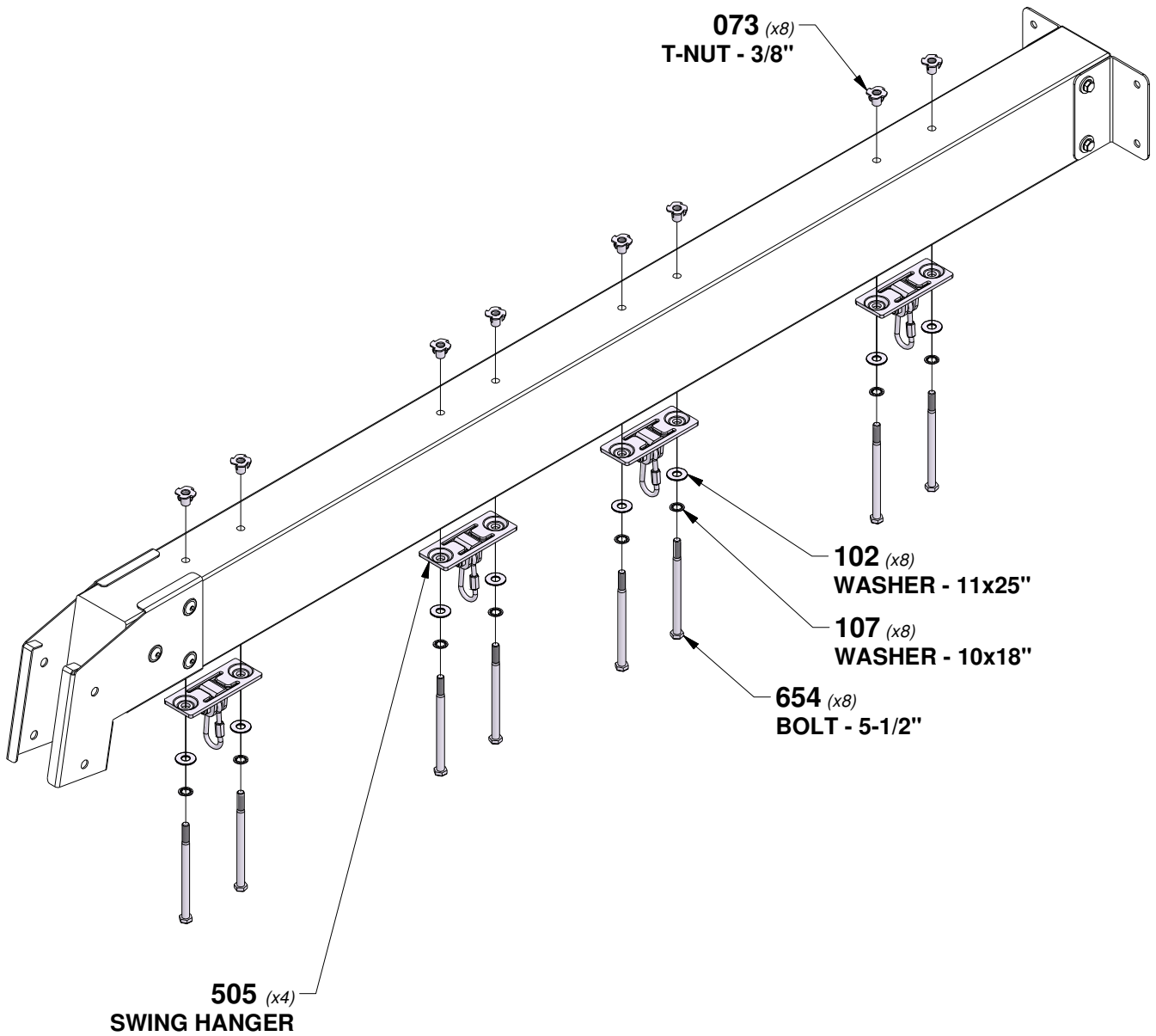

STEP 3 - SWING BEAM ASSEMBLY

QTY	PART NUMBER	DESCRIPTION
4	H100070	SCREW PWH 8x3/4



A100164 (x1) | BYD ID TAG
(LARGE) AGES
3-10

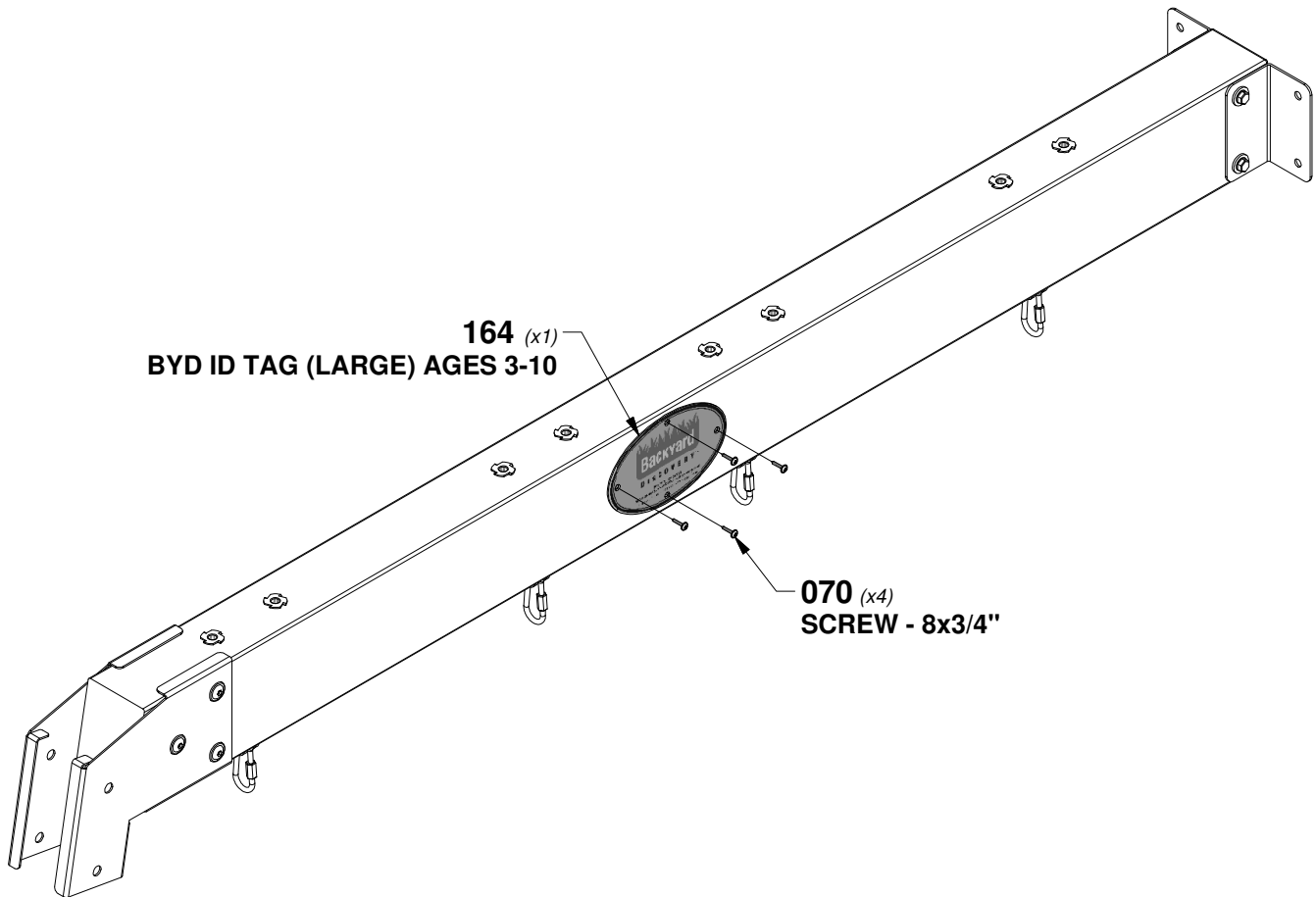

STEP 4 - SWING BEAM ASSEMBLY

QTY	PART NUMBER	DESCRIPTION
6	H100379	T-NUT 5/16 BLK
4	H100416	BOLT WH 5/16x3 BLK
2	H100503	BOLT WH 5/16x3-1/2 BLK



SP01 | SWING BEAM SUPPORT - W4L15992
(x1) | 3 3/8"x3 3/8"x50" (86x86x1269)



B50 | ANGLE BRACE - W4L15993
(x2) | 3"x3"x87 1/8" (76x76x2212)

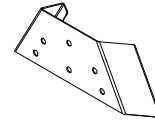

A4M01498 | A-FRAME BRACKET
(x1)

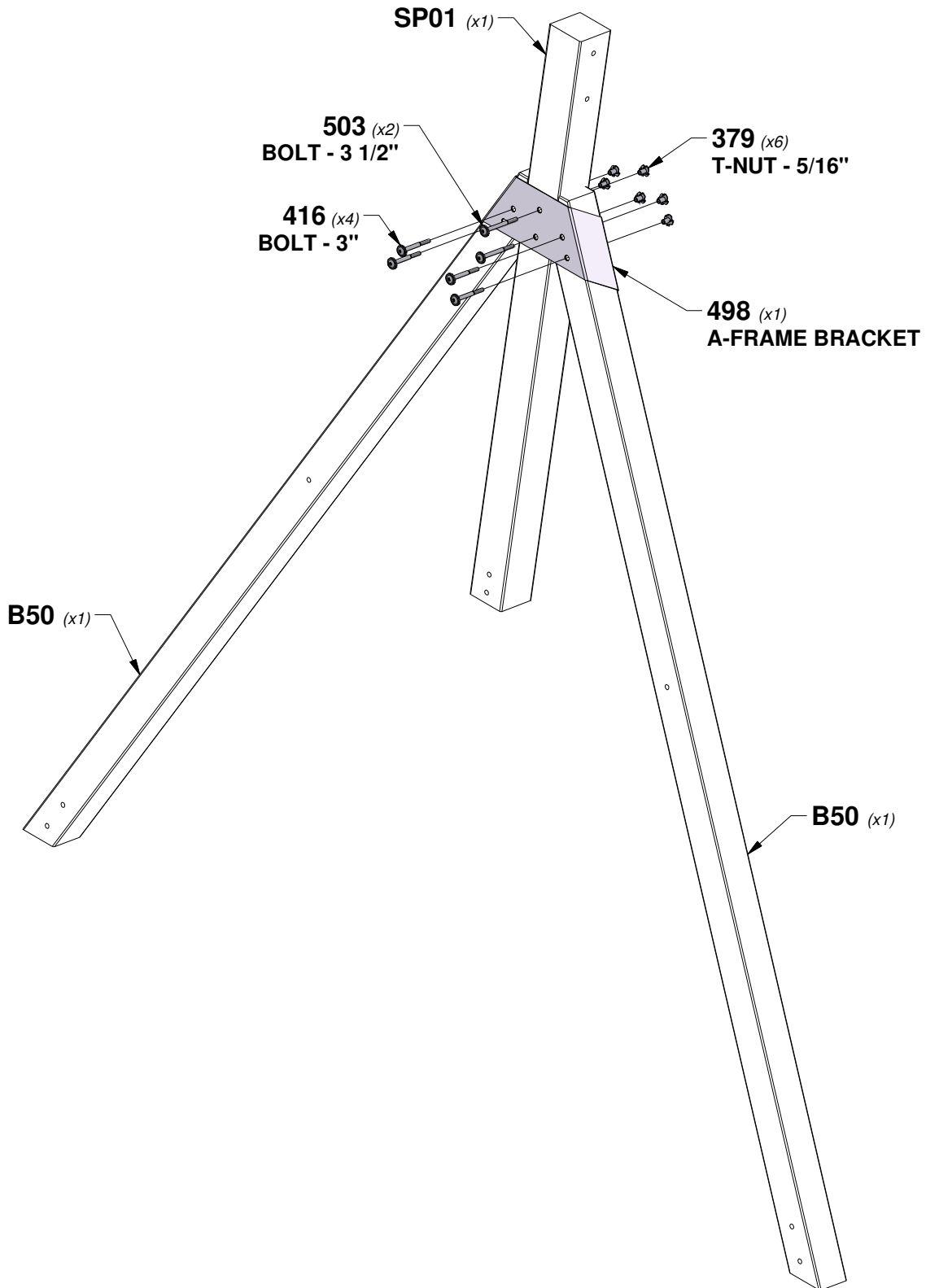

STEP 5 - SWING BEAM ASSEMBLY

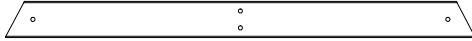

E50 | END SUPPORT - W4L15994
(x1) | 1 3/8"x3 3/8"x44 1/8" (36x86x1120)

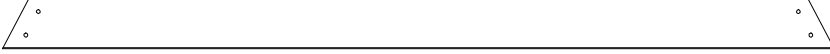

G50 | GROUND BOARD - W4L15995
(x1) | 1"x5 1/4"x86 3/4" (24x134x2202)

QTY	PART NUMBER	DESCRIPTION
4	H100019	BOLT WH 5/16x3 3/4
8	H100030	WASHER LOCK EXT 8x19
8	H100074	T-NUT 5/16
2	H100166	BOLT WH 5/16x4 1/4
2	H100505	BOLT WH 5/16x4 3/4

TIP:
INSTALL T-NUTS IN WOOD FIRST

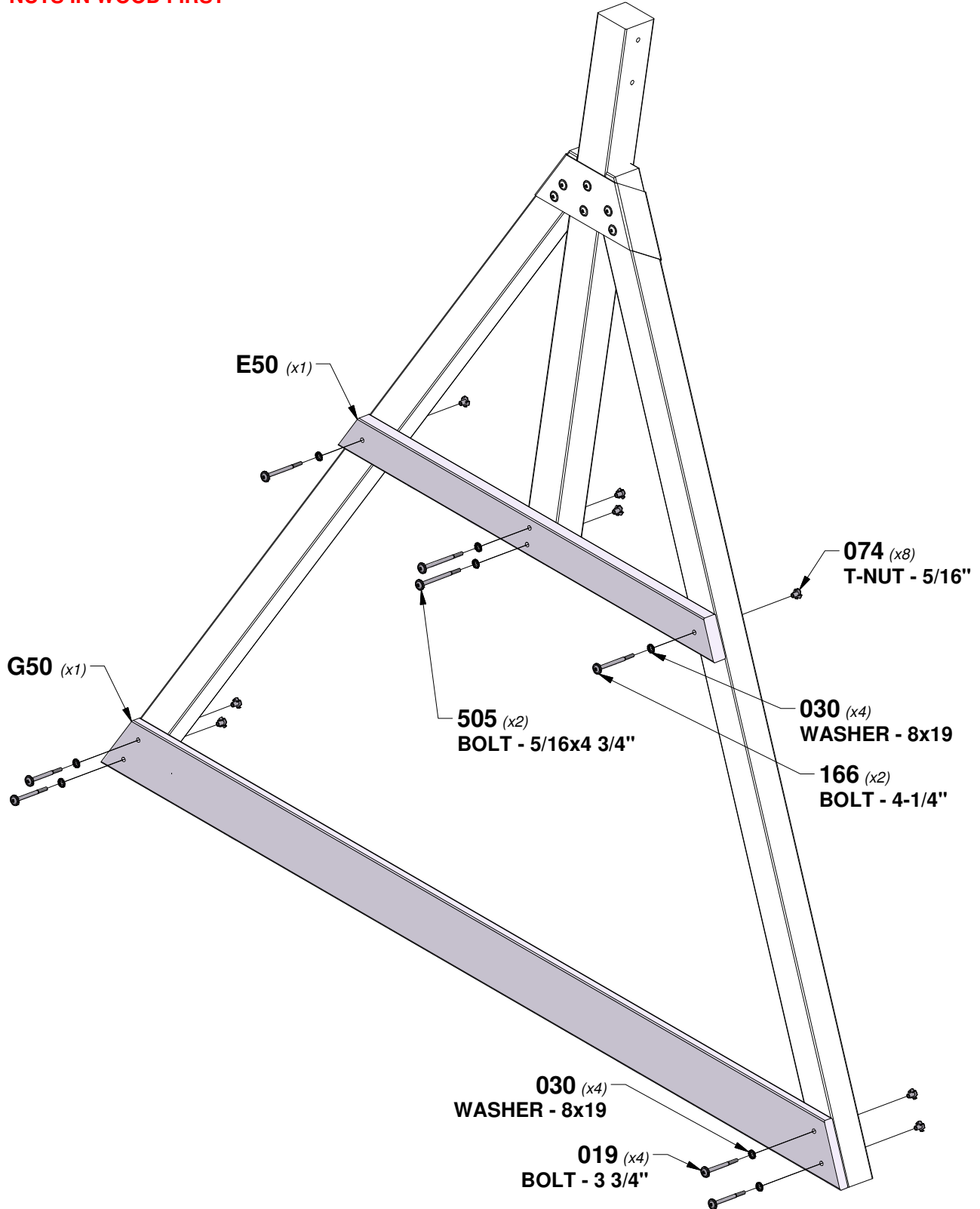

STEP 6 - SWING BEAM ASSEMBLY

QTY	PART NUMBER	DESCRIPTION
2	H100192	NUT BARREL WH 5/16x7/8 BLK
2	H100416	BOLT WH 5/16x3 BLK

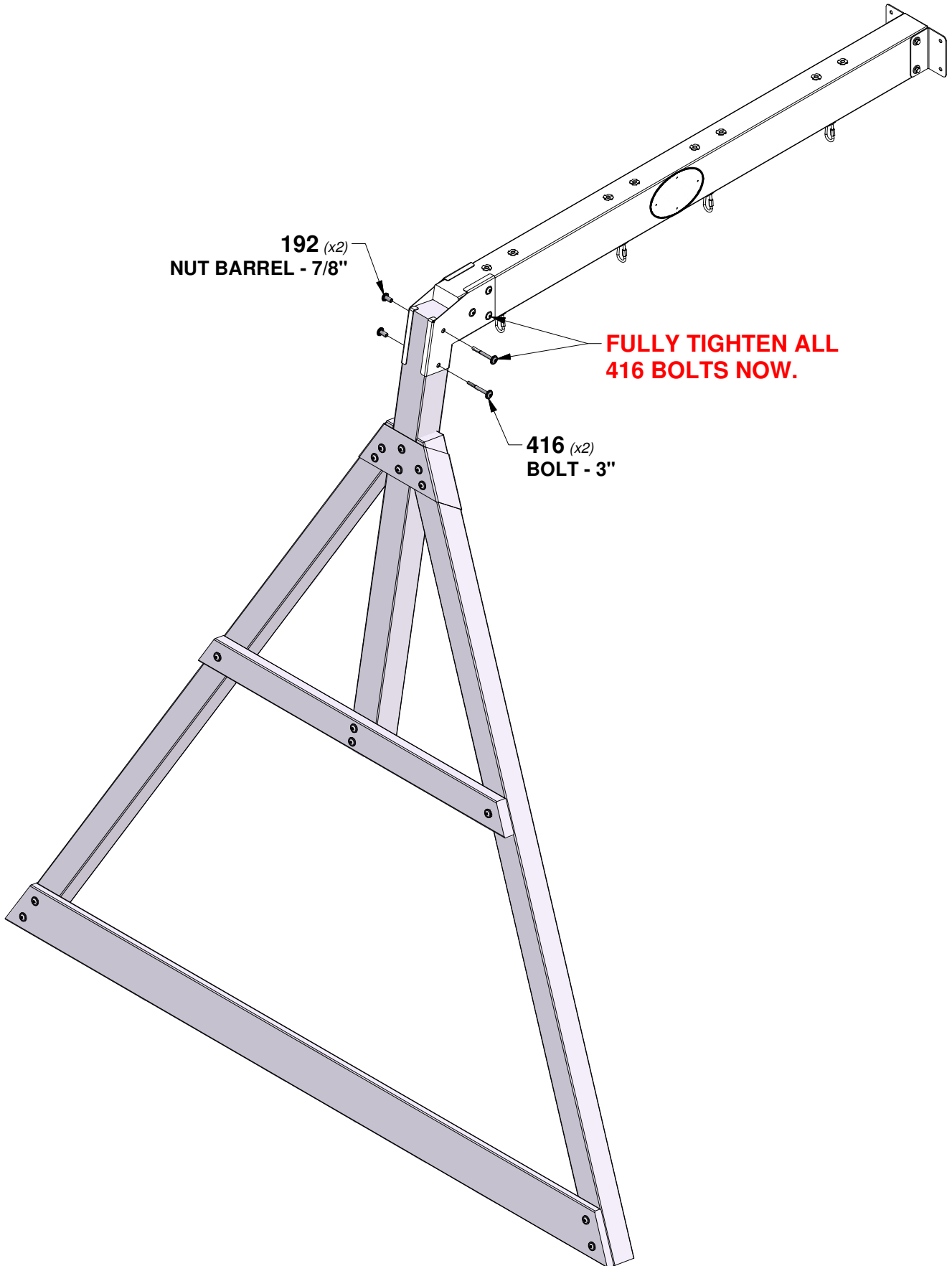

STEP 1 - FORT ASSEMBLY

QTY	PART NUMBER	DESCRIPTION
6	H100019	BOLT WH 5/16x3 3/4
10	H100030	WASHER LOCK EXT 8x19
16	H100074	T-NUT 5/16
4	H100166	BOLT WH 5/16x4-1/4
2	H100416	BOLT WH 5/16x3 BLK

B01 | UPRIGHT - W4L15718
(x1) | 3"x3"x55 1/2" (76x76x1410)

B06 | UPRIGHT - W4L15728
(x1) | 3"x3"x55 1/2" (76x76x1410)

H08 | WALL RAIL - W4L15984
(x1) | 1"x3 3/8"x59 1/8" (24x86x1501)

D01 | WALL RAIL - W4L15729
(x1) | 1 3/8"x5 1/4"x59 1/8" (36x134x1501)

Q01 | FLOOR RAIL - W4L15717
(x1) | 1"x4 3/8"x74 3/8" (24x112x1890)

A4M01481 | A-FRAME
BRACKET-RT
(x1)

A4M01482 | A-FRAME
BRACKET-LT
(x1)

TIP:
INSTALL T-NUTS IN WOOD FIRST

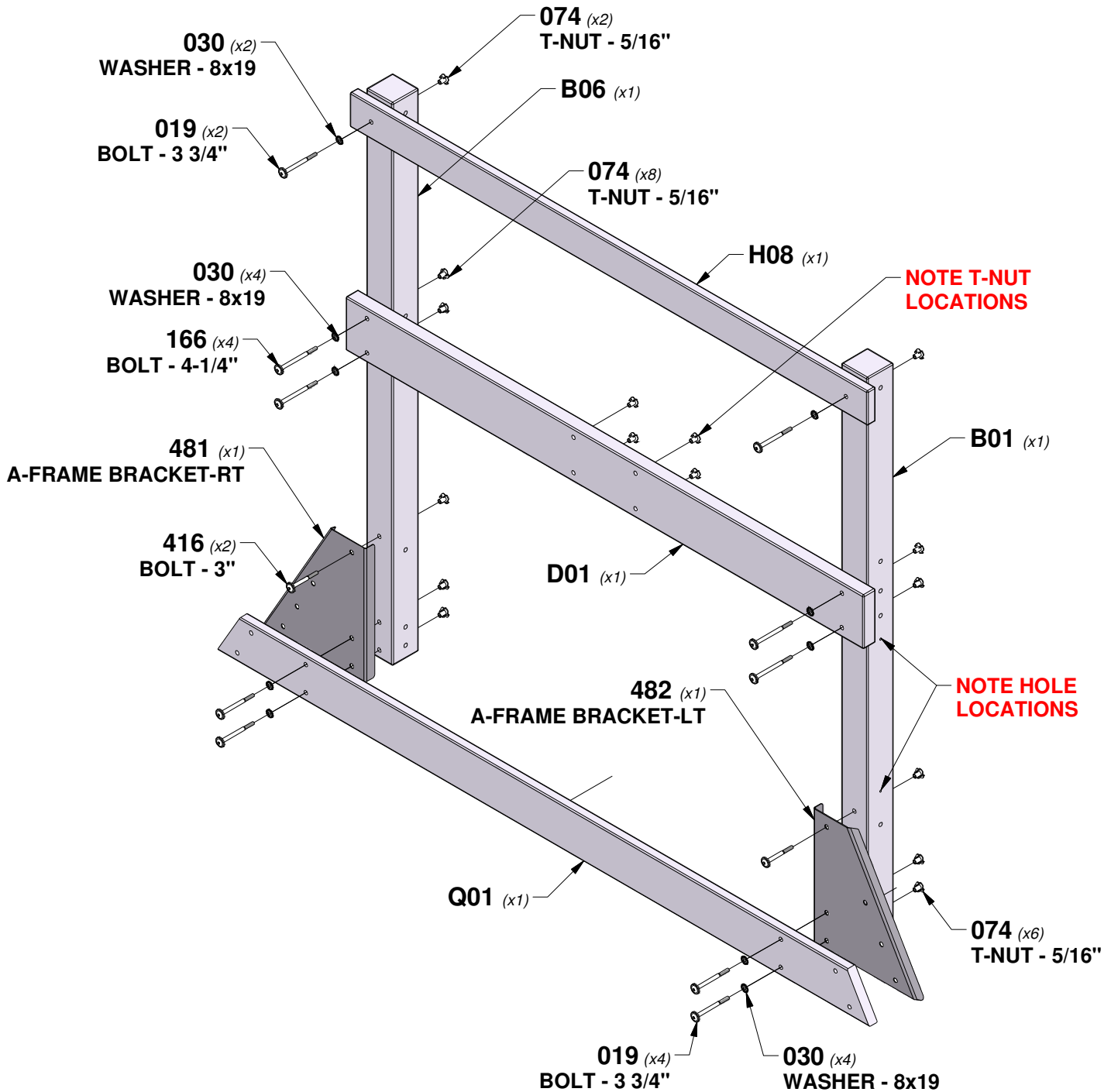

STEP 2 - FORT ASSEMBLY

QTY	PART NUMBER	DESCRIPTION
4	H100019	BOLT WH 5/16x3 3/4
2	H100022	BOLT WH 5/16x5
6	H100030	WASHER LOCK EXT 8x19
6	H100074	T-NUT 5/16

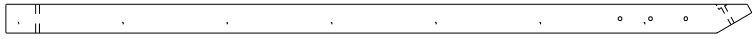

B02 | LEG - W4L15719
(x1) | 3"x3"x77 3/4" (76x76x1975)



B03 | LEG - W2A03278
(x1) | 3"x3"x79 3/8" (76x76x2015)

TIP:
INSTALL T-NUTS IN WOOD FIRST

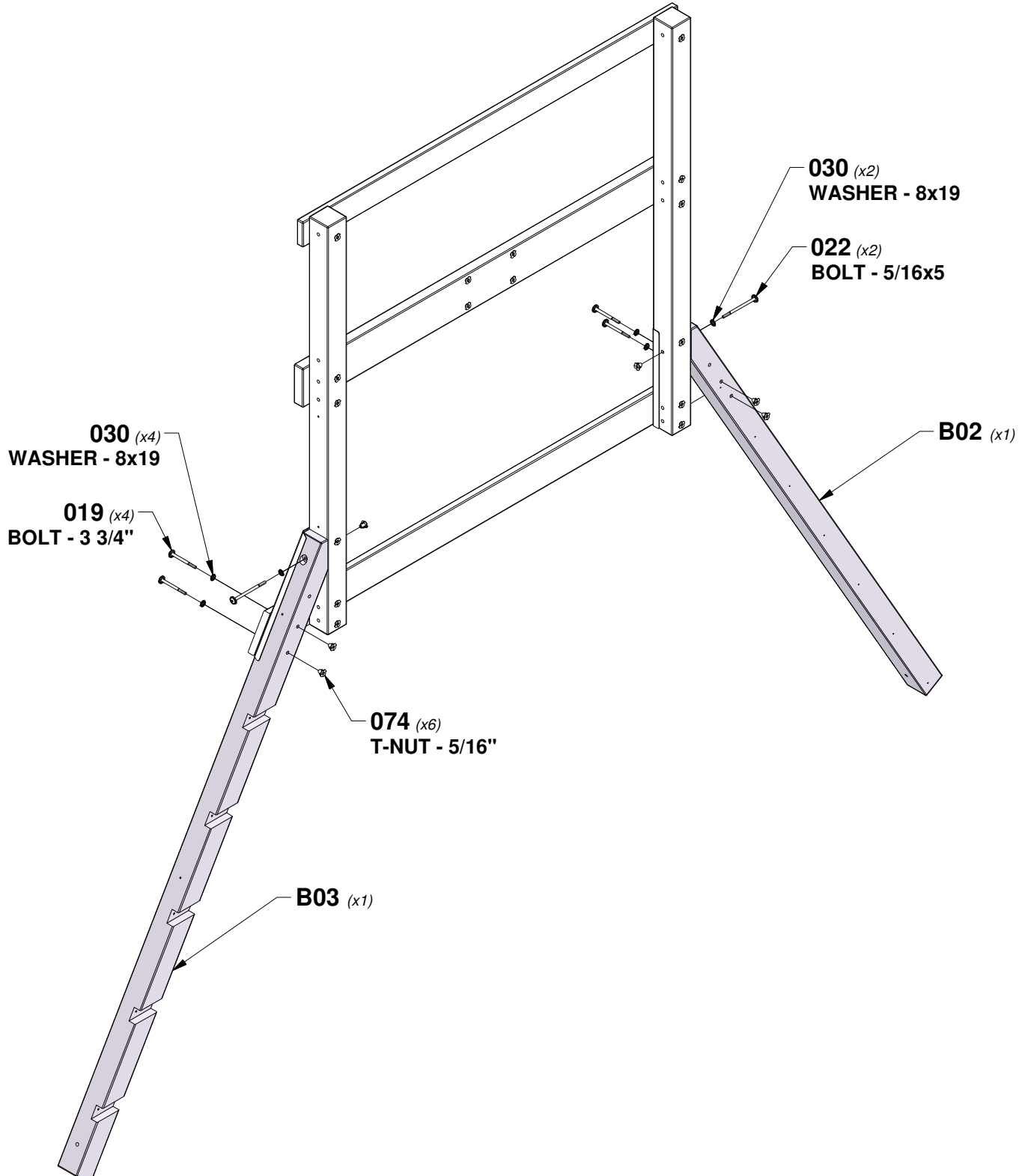

STEP 3 - FORT ASSEMBLY

QTY	PART NUMBER	DESCRIPTION
10	H100019	BOLT WH 5/16x3 3/4
10	H100030	WASHER LOCK EXT 8x19
12	H100074	T-NUT 5/16
2	H100416	BOLT WH 5/16x3 BLK

B01 | UPRIGHT - W4L15718
(x1) | 3"x3"x55 1/2" (76x76x1410)

B06 | UPRIGHT - W4L15728
(x1) | 3"x3"x55 1/2" (76x76x1410)

H08 | WALL RAIL - W4L15984
(x1) | 1"x3 3/8"x59 1/8" (24x86x1501)

G02 | WALL RAIL - W4L15726
(x1) | 1"x5 1/4"x59 1/8" (24x134x1501)

Q01 | FLOOR RAIL - W4L15717
(x1) | 1"x4 3/8"x74 3/8" (24x112x1890)

A4M01481 | A-FRAME
BRACKET-RT
(x1)

A4M01482 | A-FRAME
BRACKET-LT
(x1)

TIP:
INSTALL T-NUTS IN WOOD FIRST

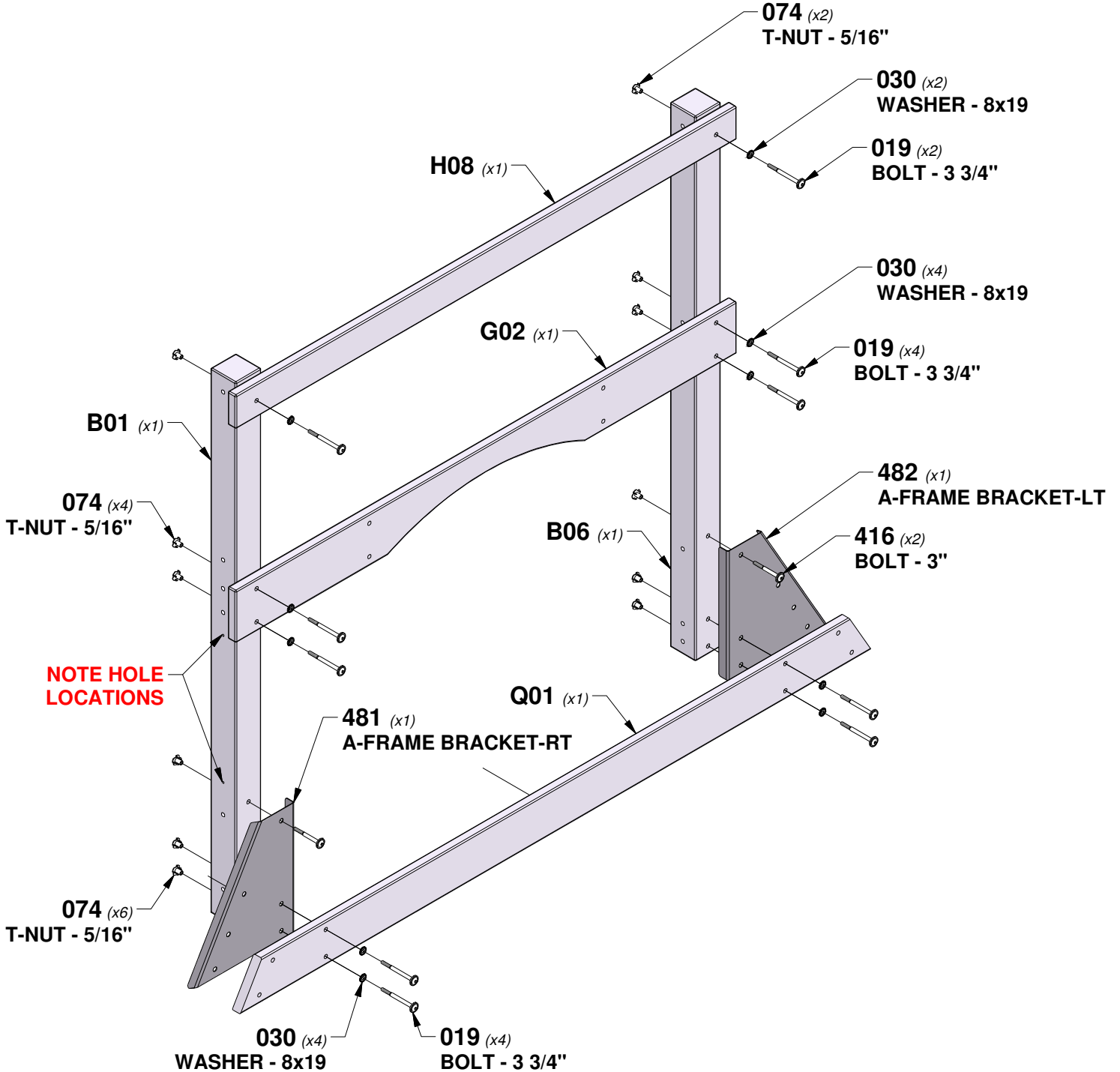

STEP 4 - FORT ASSEMBLY

QTY	PART NUMBER	DESCRIPTION
4	H100019	BOLT WH 5/16x3 3/4
2	H100022	BOLT WH 5/16x5
6	H100030	WASHER LOCK EXT 8x19
6	H100074	T-NUT 5/16



B02 | LEG - W4L15719
(x1) | 3"x3"x77 3/4" (76x76x1975)



B11 | LEG - W4L15747
(x1) | 3"x3"x77 3/4" (76x76x1975)

TIP:
INSTALL T-NUTS IN WOOD FIRST

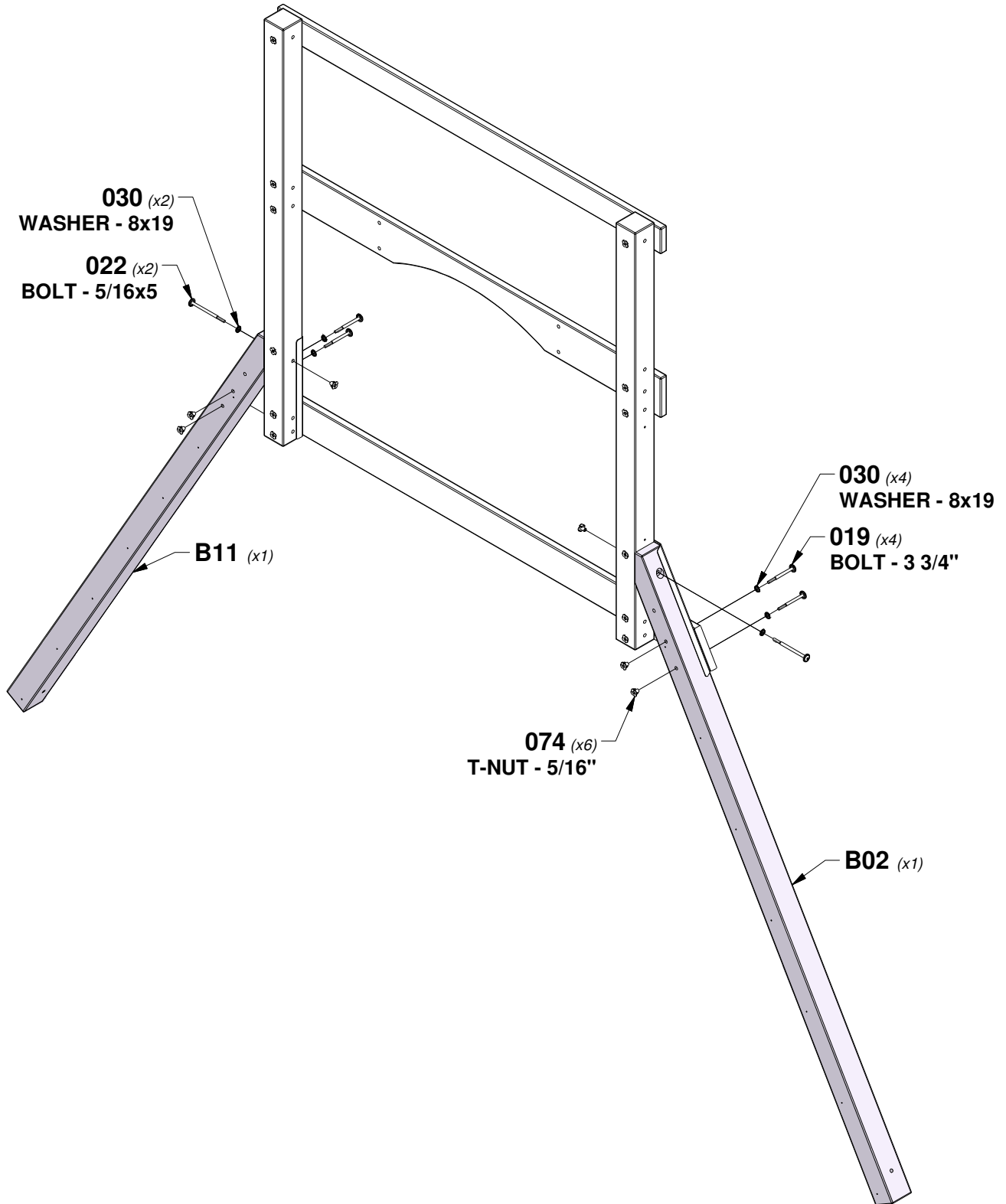

STEP 5 - FORT ASSEMBLY

QTY	PART NUMBER	DESCRIPTION
2	H100019	BOLT WH 5/16x3 3/4
2	H100030	WASHER LOCK EXT 8x19
2	H100074	T-NUT 5/16

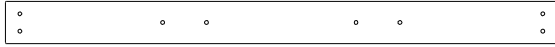

Q03 FLOOR RAIL - W4L15724
(x1) 1"x4 3/8"x57 1/2" (24x112x1460)

TIP:
INSTALL T-NUTS IN WOOD FIRST

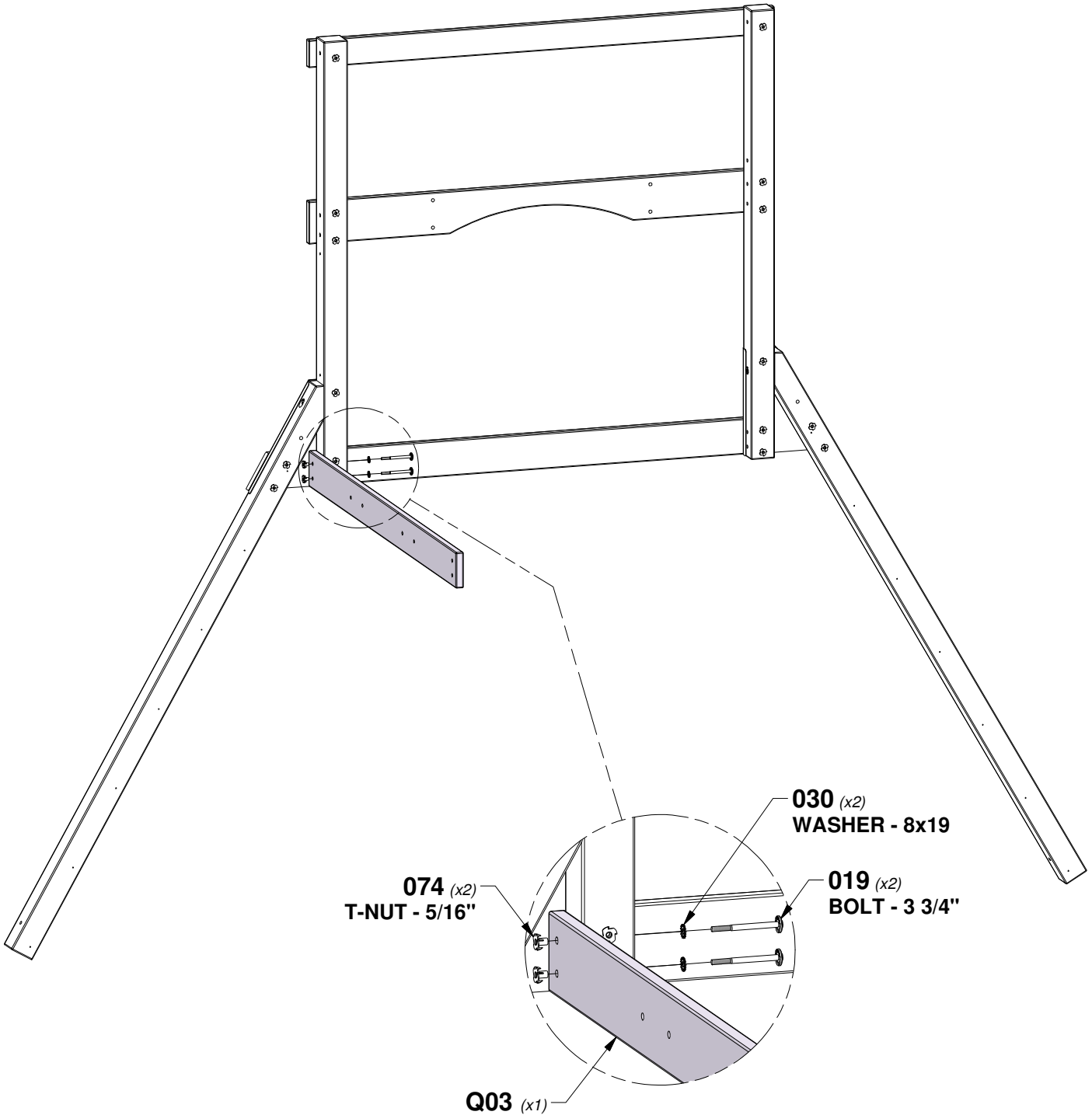

STEP 6 - FORT ASSEMBLY

QTY	PART NUMBER	DESCRIPTION
2	H100019	BOLT WH 5/16x3 3/4
2	H100030	WASHER LOCK EXT 8x19
2	H100074	T-NUT 5/16

TIP:
INSTALL T-NUTS IN WOOD FIRST

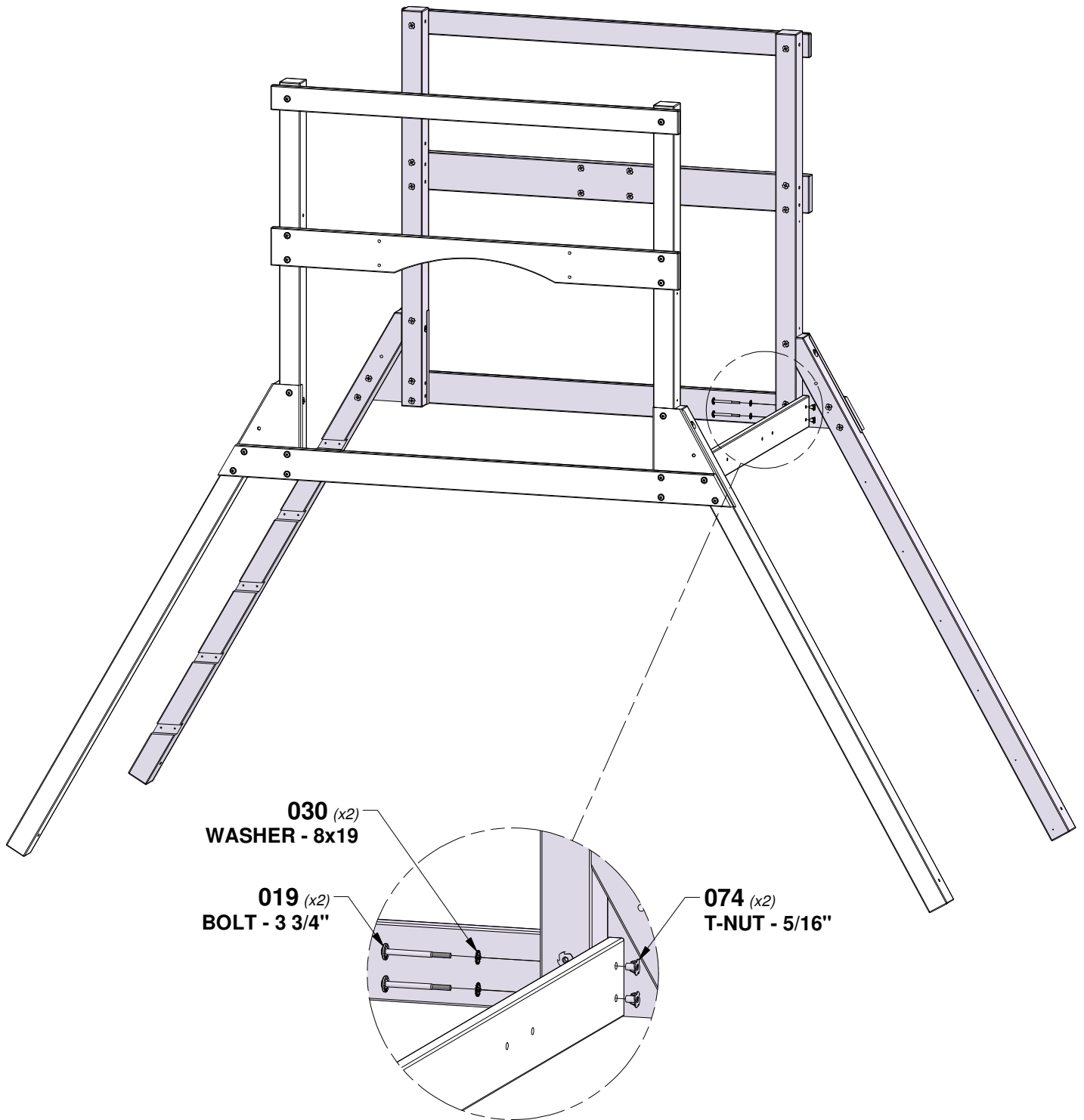

STEP 7 - FORT ASSEMBLY

QTY	PART NUMBER	DESCRIPTION
4	H100019	BOLT WH 5/16x3 3/4
4	H100030	WASHER LOCK EXT 8x19
4	H100074	T-NUT 5/16



Q02 | FLOOR RAIL - W4L15721
 (x1) | 1"x4 3/8"x57 1/2" (24x112x1460)

TIP:
INSTALL T-NUTS IN WOOD FIRST

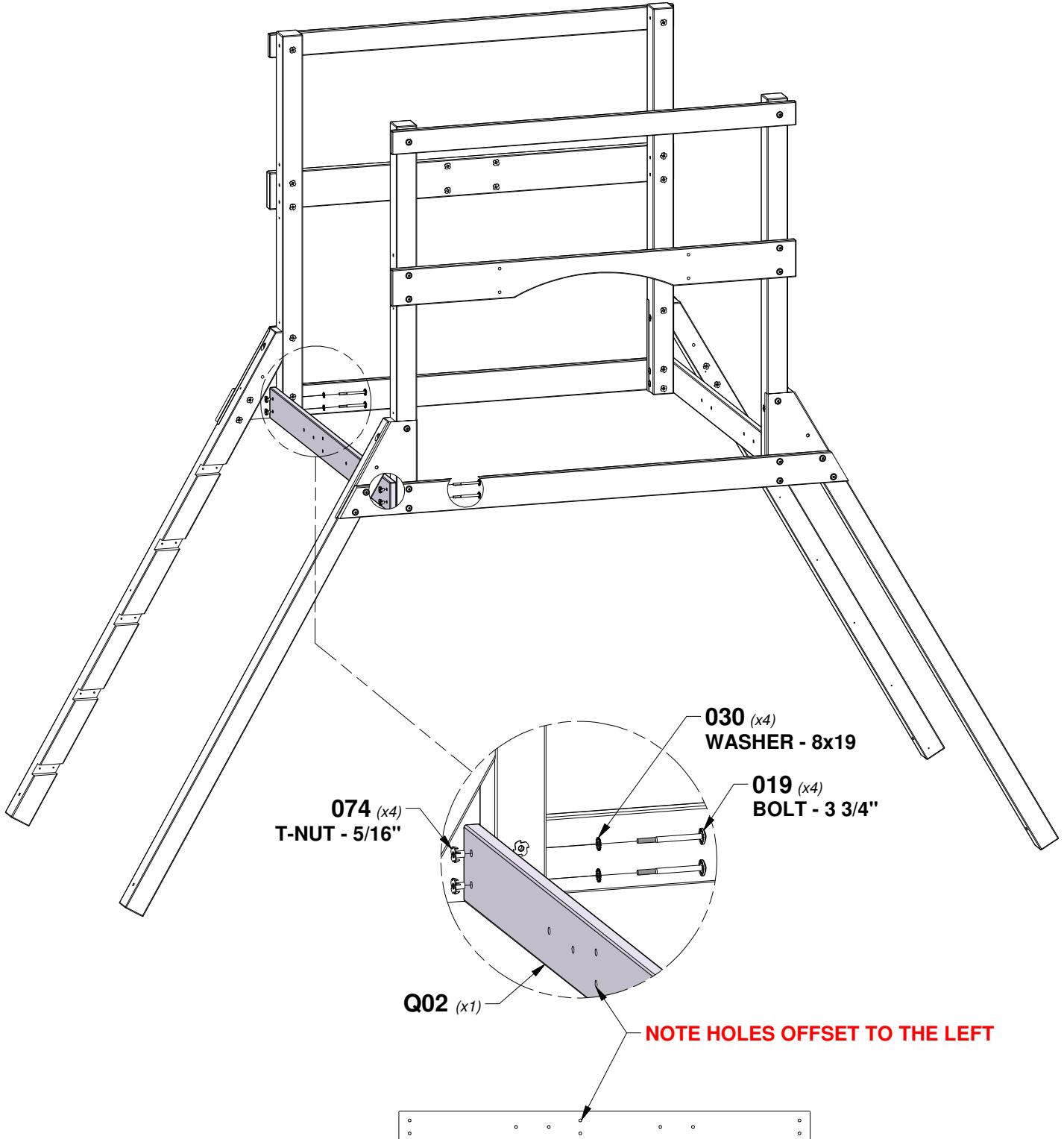

STEP 8 - FORT ASSEMBLY

QTY	PART NUMBER	DESCRIPTION
4	H100074	T-NUT 5/16
4	H100030	WASHER LOCK EXT 8x19
4	H100023	BOLT WH 5/16X6

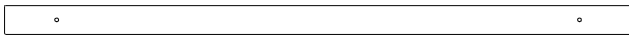

B12 | GROUND BOARD - W4L15976
(x1) | 3"x3"x65 3/8" (76x76x1660)

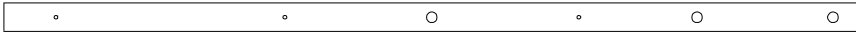

B07 | GROUND BOARD - W4L15733
(x1) | 3"x3"x89 3/8" (76x76x2270)

TIP:
INSTALL T-NUTS IN WOOD FIRST

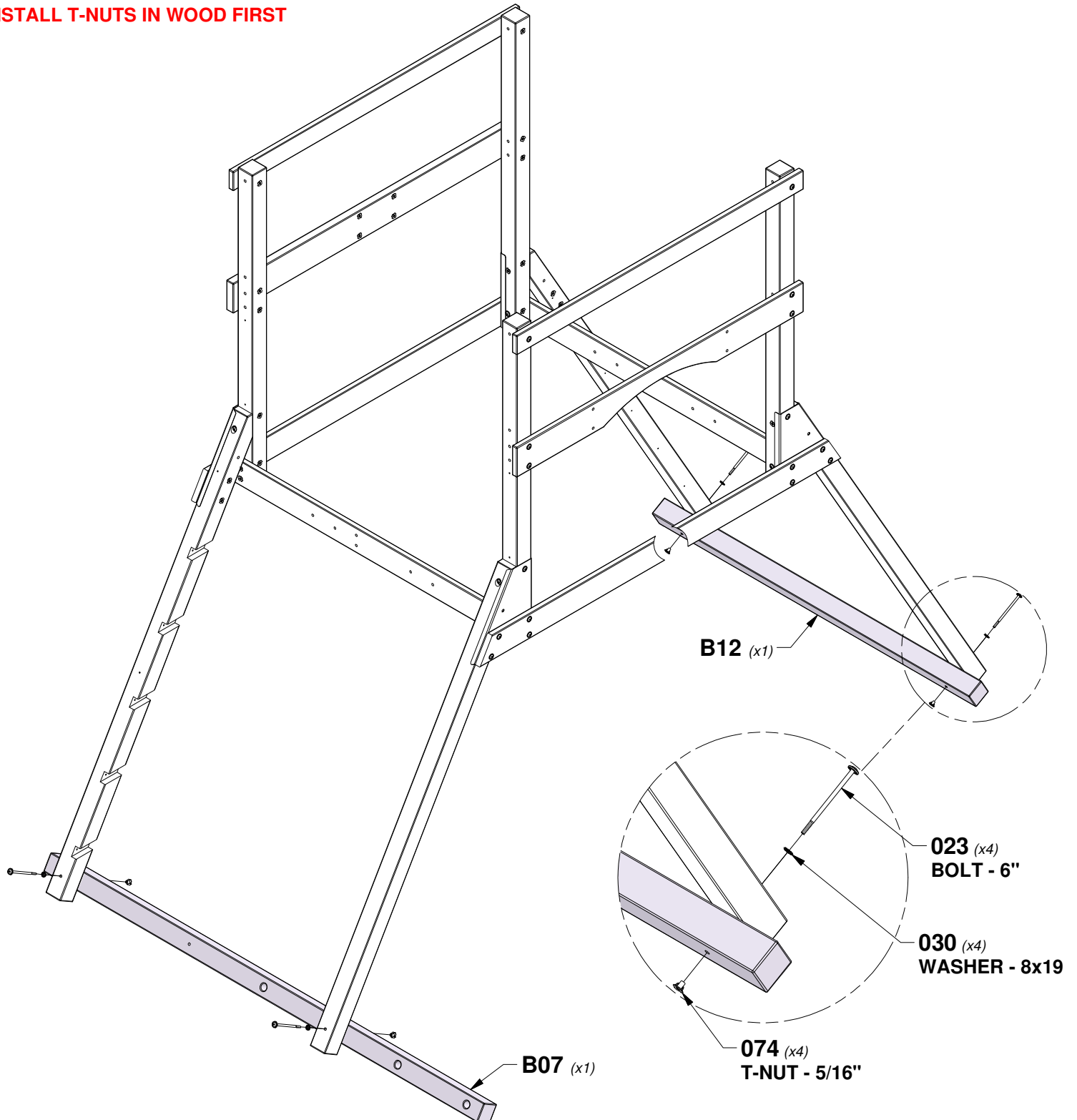

STEP 9 - FORT ASSEMBLY

QTY	PART NUMBER	DESCRIPTION
8	H100005	NUT BARREL WH 5/16x7/8
8	H100031	WASHER LOCK EXT 12x19
2	H100128	SCREW PWH 8x5/8
4	H100192	NUT BARREL WH 5/16x7/8 BLK
4	H100195	BOLT WH 5/16x2-3/4 BLK
8	H100396	BOLT WH 5/16x1/2 BLK

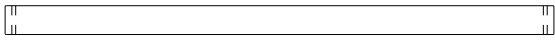

B05 | FLOOR JOIST - W4L15723
(x1) | 3"x3"x57 1/4" (76x76x1453)

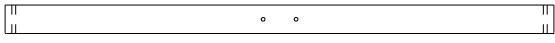

B10 | FLOOR JOIST - W4L15741
(x1) | 3"x3"x57 1/4" (76x76x1453)



A100314 | "A" REVISION TAG
(x1)

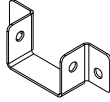

A4M01480 | JOIST HANGER
(x4) | 90°

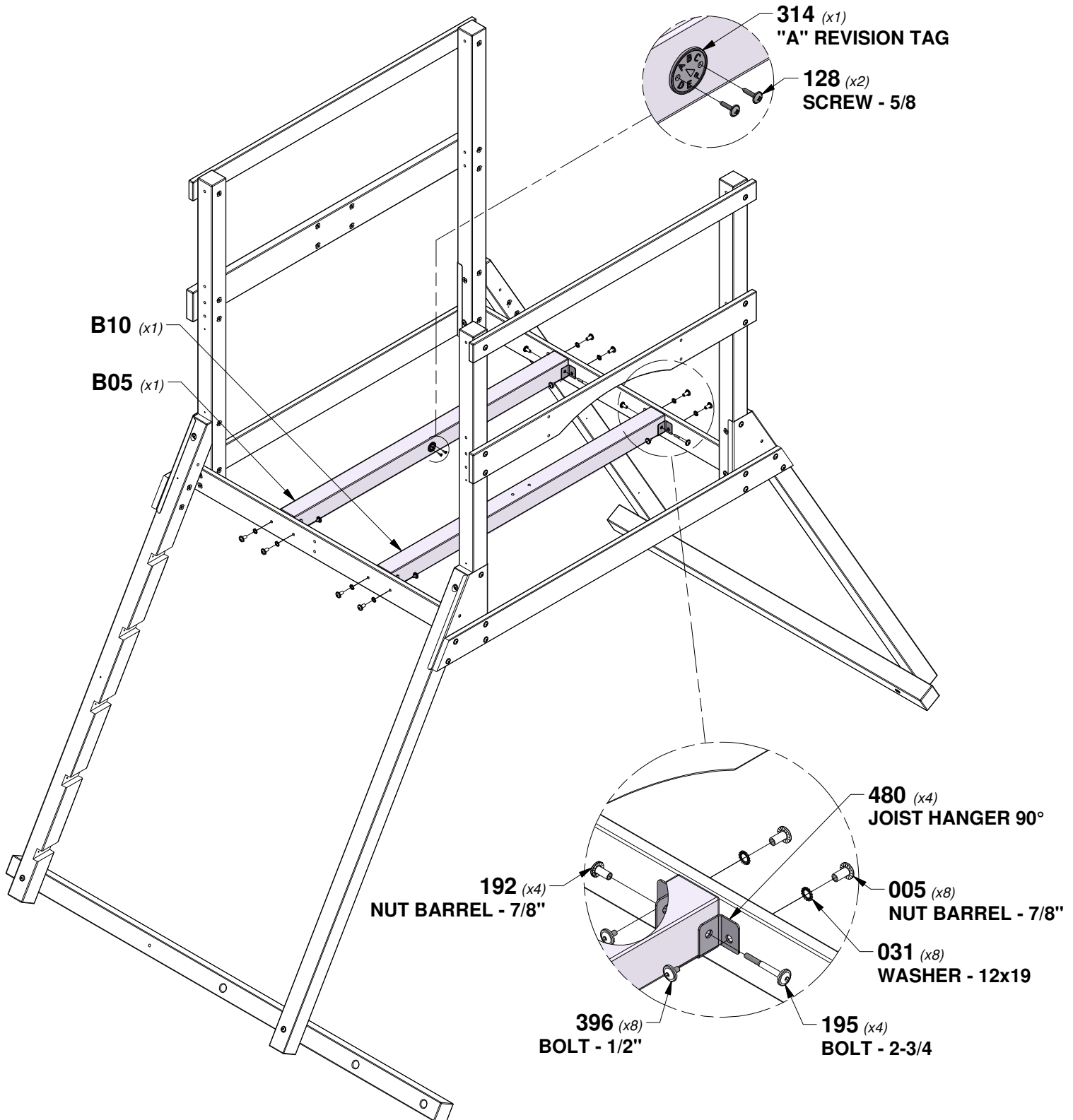

STEP 10 - FORT ASSEMBLY

QTY	PART NUMBER	DESCRIPTION
2	H100019	BOLT WH 5/16x3 3/4
2	H100030	WASHER LOCK EXT 8x19
2	H100074	T-NUT 5/16
4	H100091	SCREW PFH 8x2 1/4



B04 | UPRIGHT - W4L15722
(x1) | 3"x3"x38" (76x76x964)



H03 | FLOOR RAIL - W4L15736
(x2) | 1"x3"x3 3/8" (24x76x86)

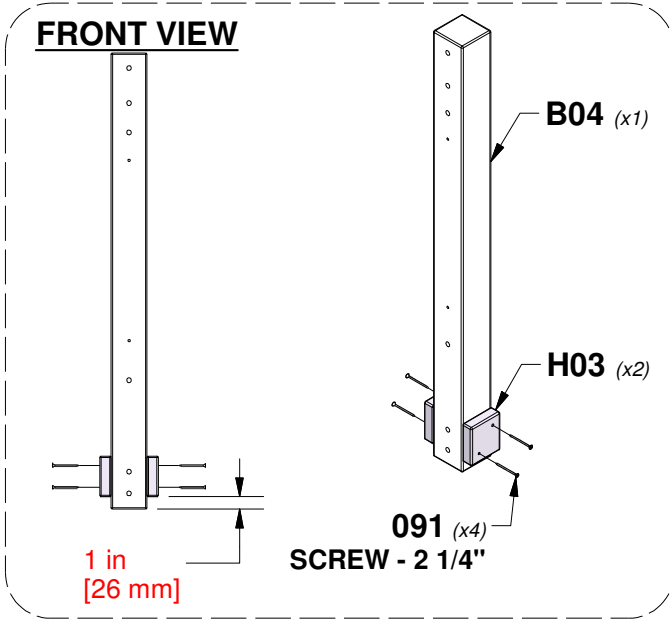

INSTALL BOTH H03 BOARDS TO B04 BOARD FIRST

NOTE HOLE LOCATIONS

B04 (x1)

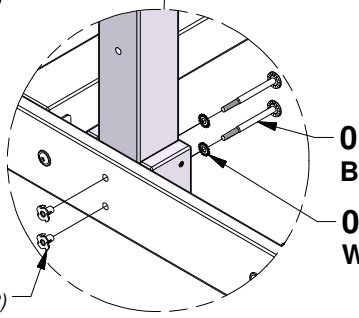
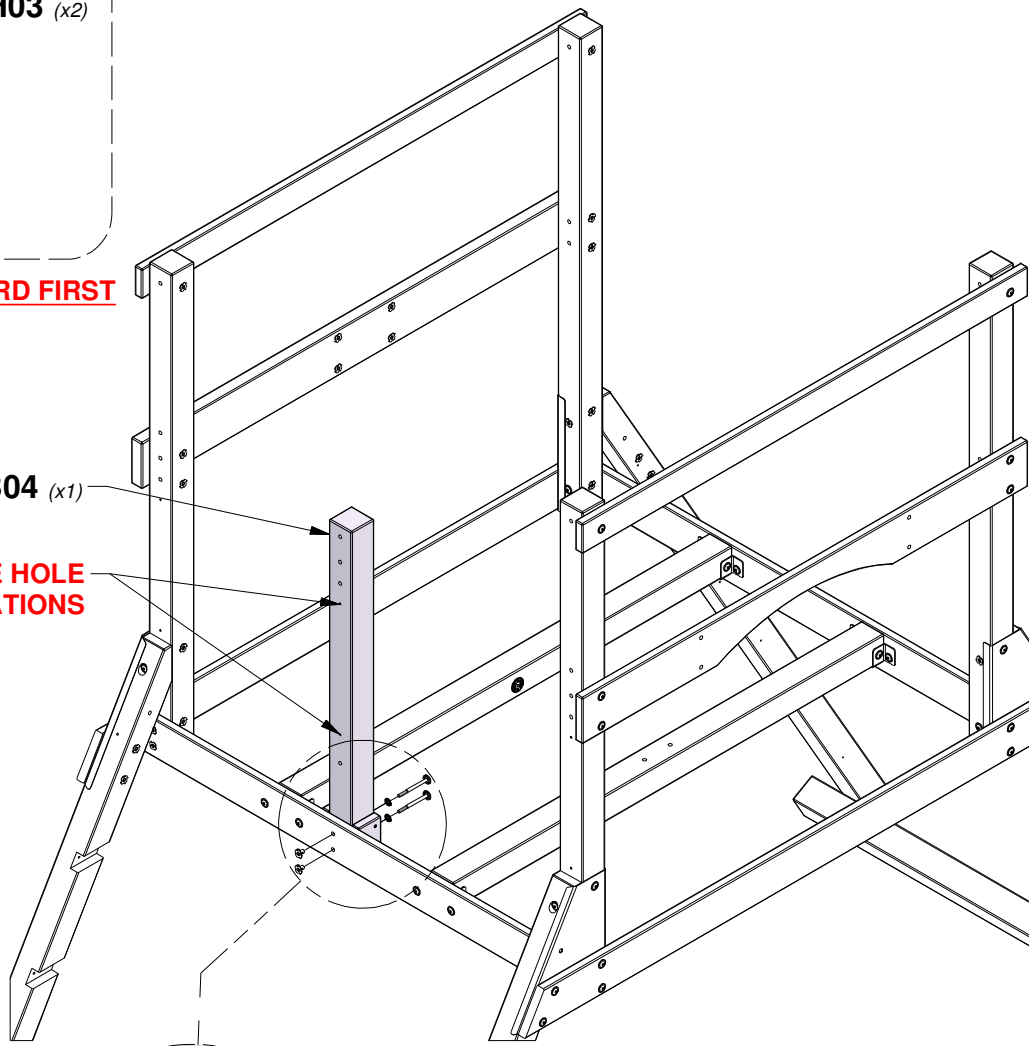

019 (x2)
BOLT - 3 3/4"

030 (x2)
WASHER - 8x19

074 (x2)
T-NUT - 5/16"

STEP 11 - FORT ASSEMBLY

QTY	PART NUMBER	DESCRIPTION
8	H100091	SCREW PFH 8x2 1/4



H03 FLOOR RAIL - W4L15736
(x4) 1"x3"x3 3/8" (24x76x86)

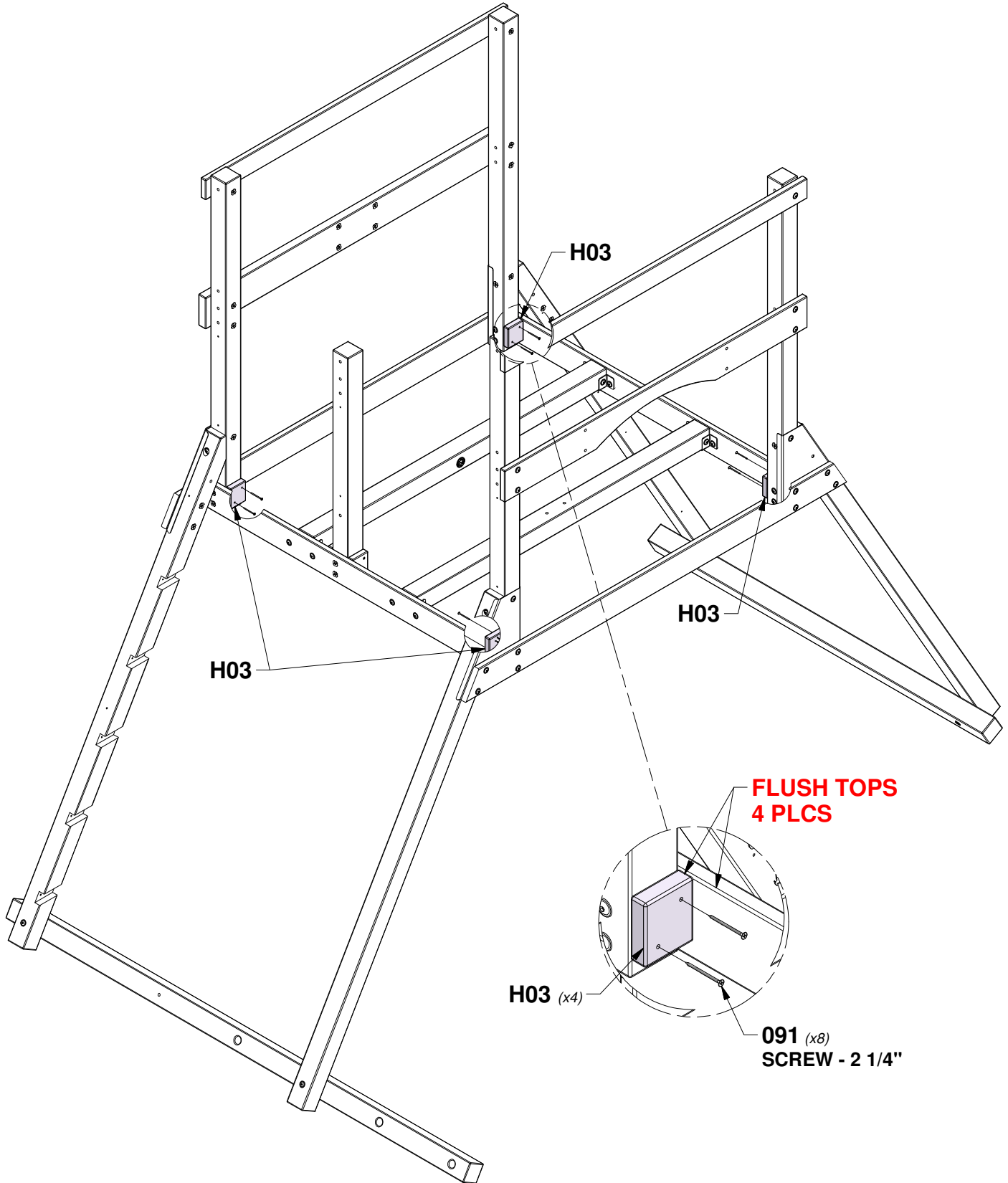

STEP 12 - FORT ASSEMBLY



B08 | LEG - W4L15739
(x1) | 3"x3"x77 3/4" (76x76x1975)

QTY	PART NUMBER	DESCRIPTION
1	H100022	BOLT WH 5/16x5
1	H100023	BOLT WH 5/16X6
2	H100030	WASHER LOCK EXT 8x19
2	H100074	T-NUT 5/16

TIP:
INSTALL T-NUTS IN WOOD FIRST

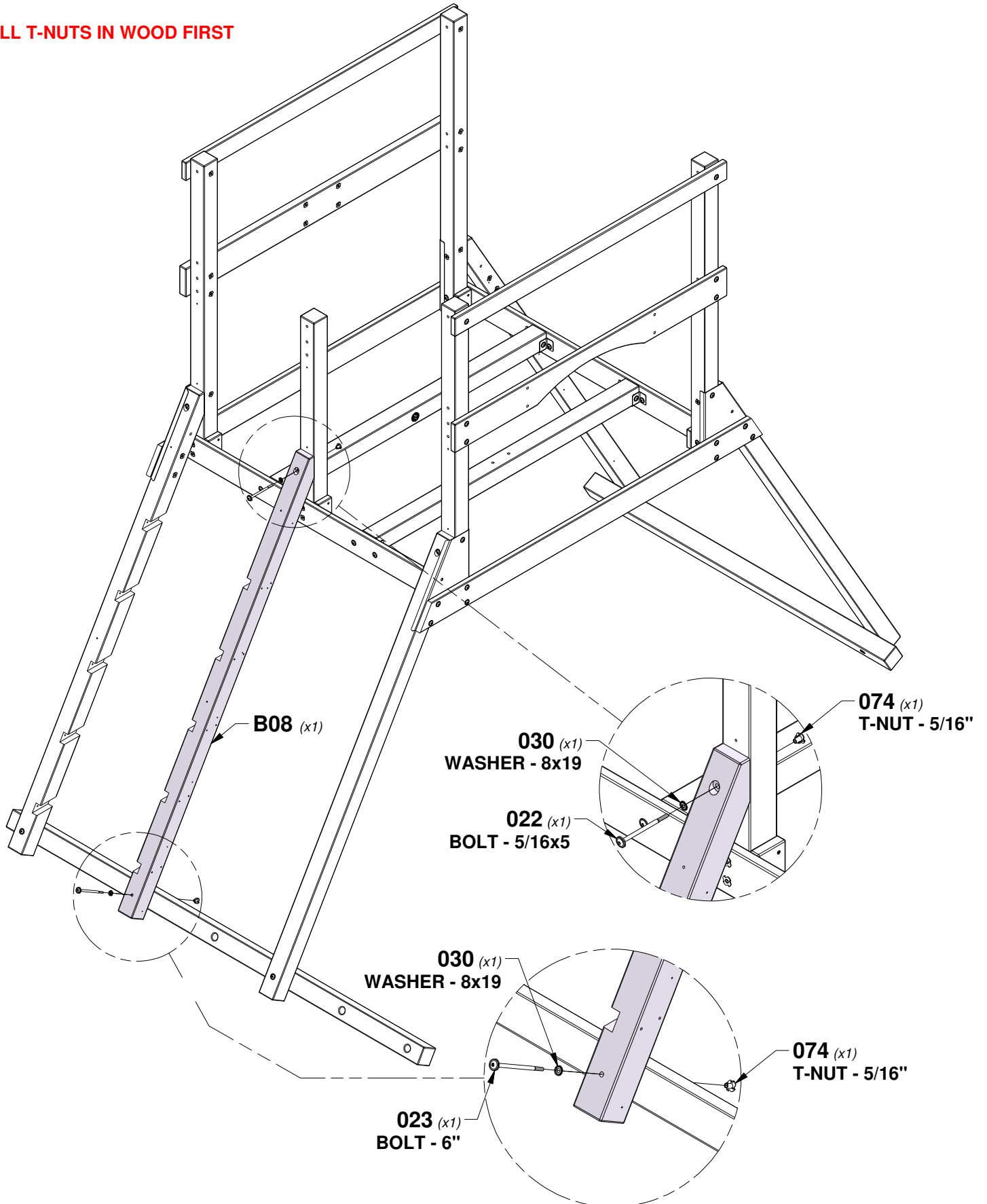

STEP 13 - FORT ASSEMBLY

QTY	PART NUMBER	DESCRIPTION
20	H100092	SCREW PFH 8x3



AL01 | STEP - W4L15737
(x5) | 1 3/8"x4 3/8"x22 3/4" (36x112x579)

**ALIGN STEPS USING
PILOT HOLES**

AL01 (x5)

092 (x20)
SCREW - 3

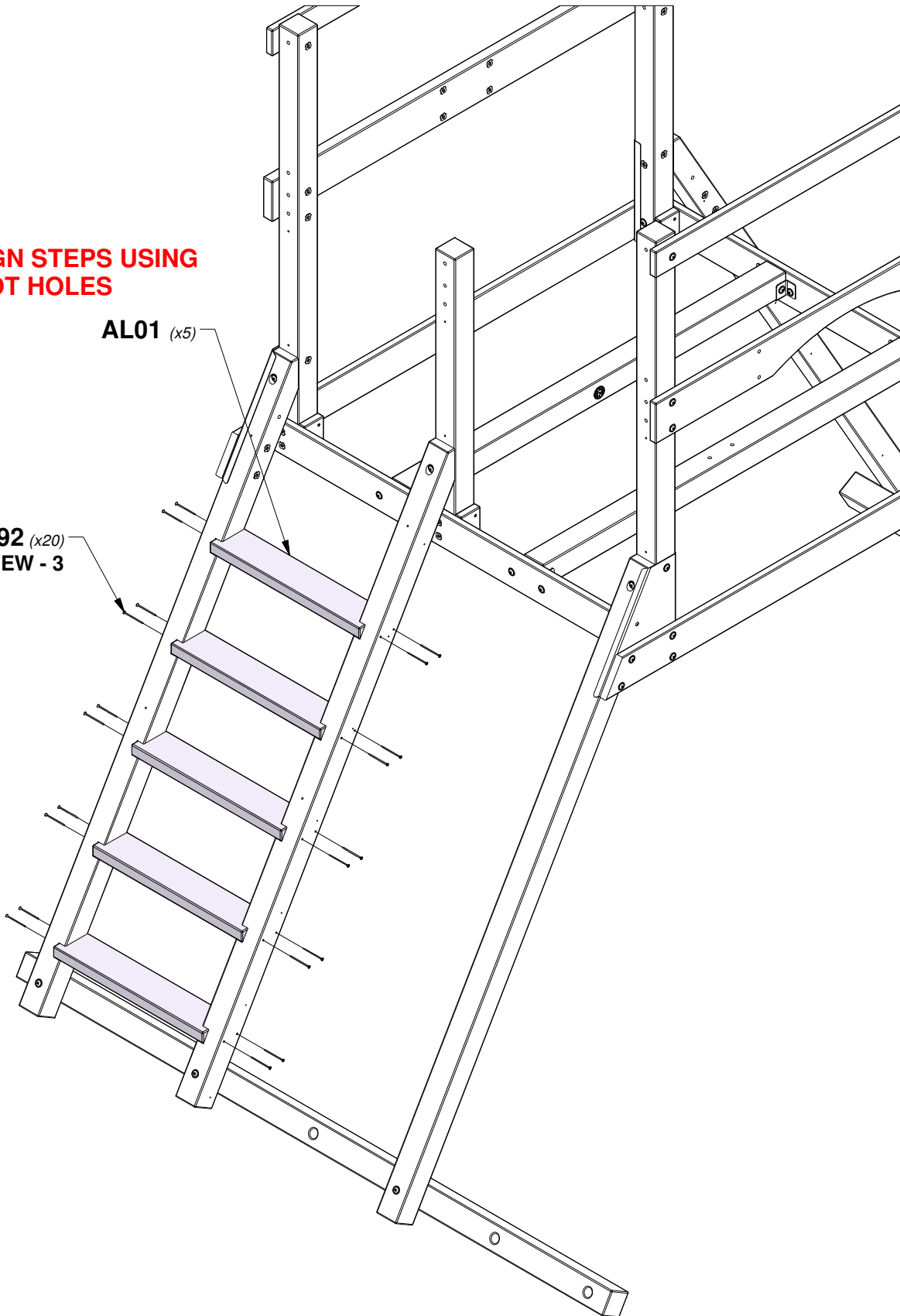

STEP 14 - FORT ASSEMBLY

QTY	PART NUMBER	DESCRIPTION
3	H100089	SCREW PFH 8x1-3/4"
14	H100092	SCREW PFH 8x3

T01 | CLEAT - W4L15748
(x1) | 1"x1 3/8"x24 1/4" (24x34x615)

F01 | CLEAT - W4L15746
(x2) | 1 3/8"x2"x68 3/4" (36x52x1747)

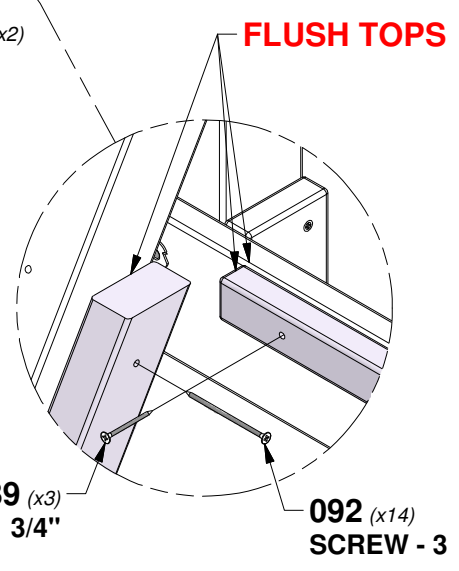
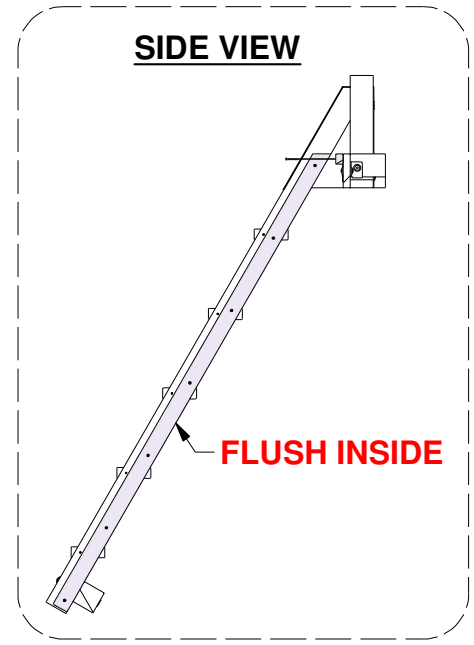
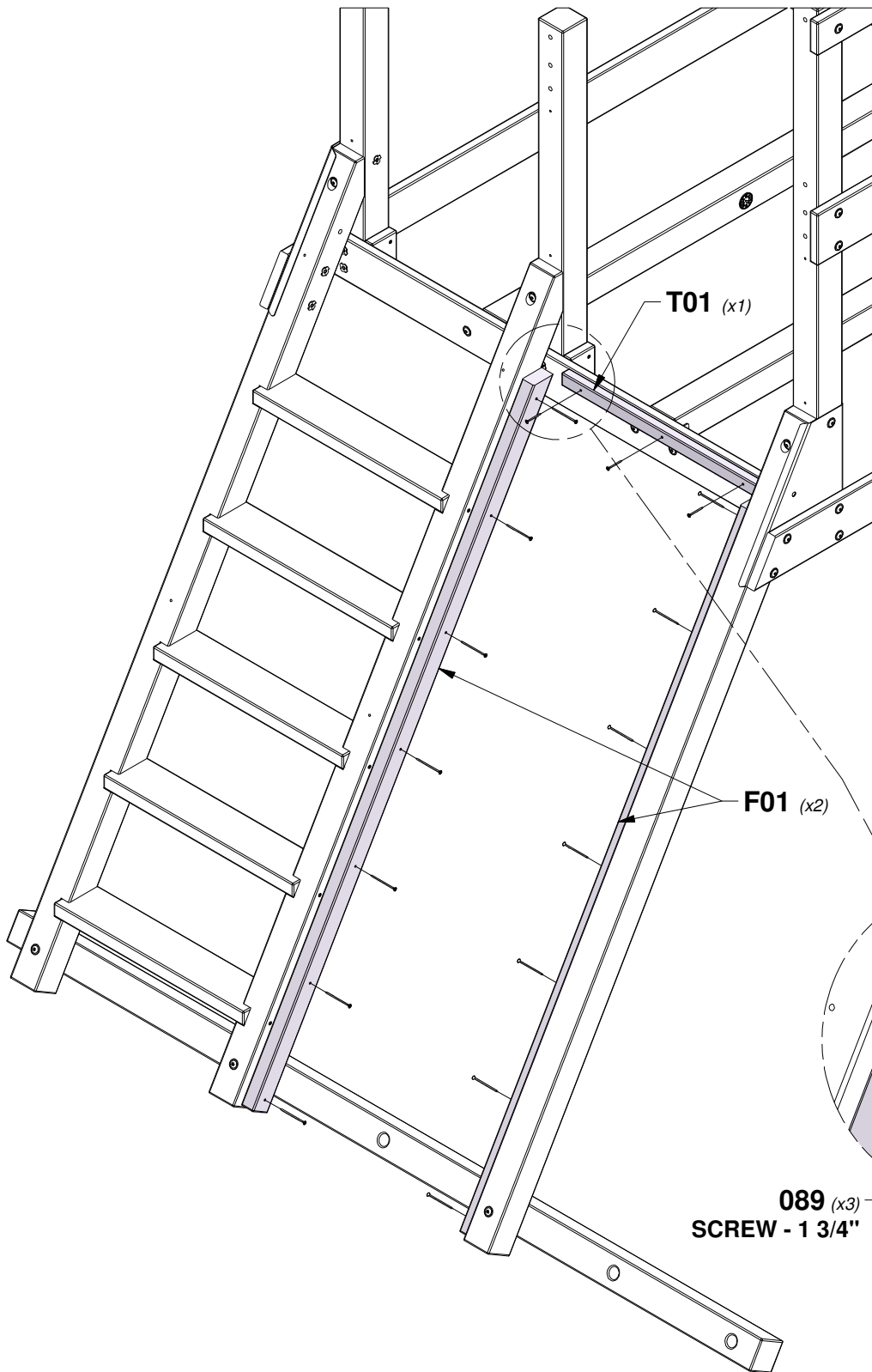

STEP 15A - FORT ASSEMBLY

QTY	PART NUMBER	DESCRIPTION
40	H100086	SCREW PFH 8x1-1/2"
40	H100111	SCREW PFH 8x2



H04 ROPE WALL BOARD - W4L15744
(x9) 1"x3 3/8"x27 5/8" (24x86x701)



H14 ROPE WALL BOARD - W4L16119
(x1) 1"x2 3/4"x27 5/8" (24x69x701)

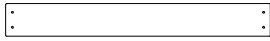

M02 ROPE WALL BOARD - W4L15742
(x9) 5/8"x3 3/8"x27 5/8" (16x86x701)

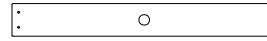

M03 ROPE WALL BOARD - W4L15981
(x1) 5/8"x3 3/8"x27 5/8" (16x86x701)

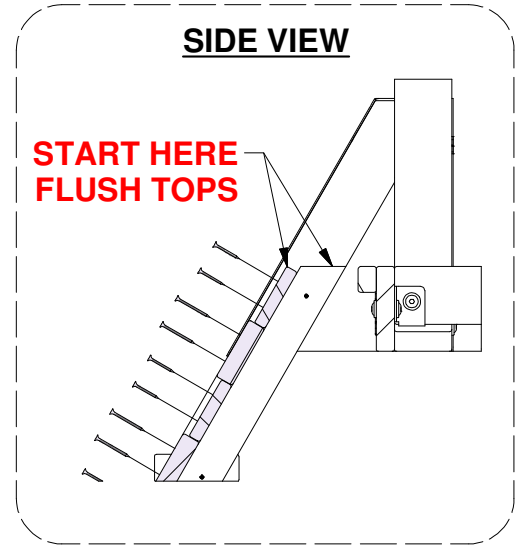
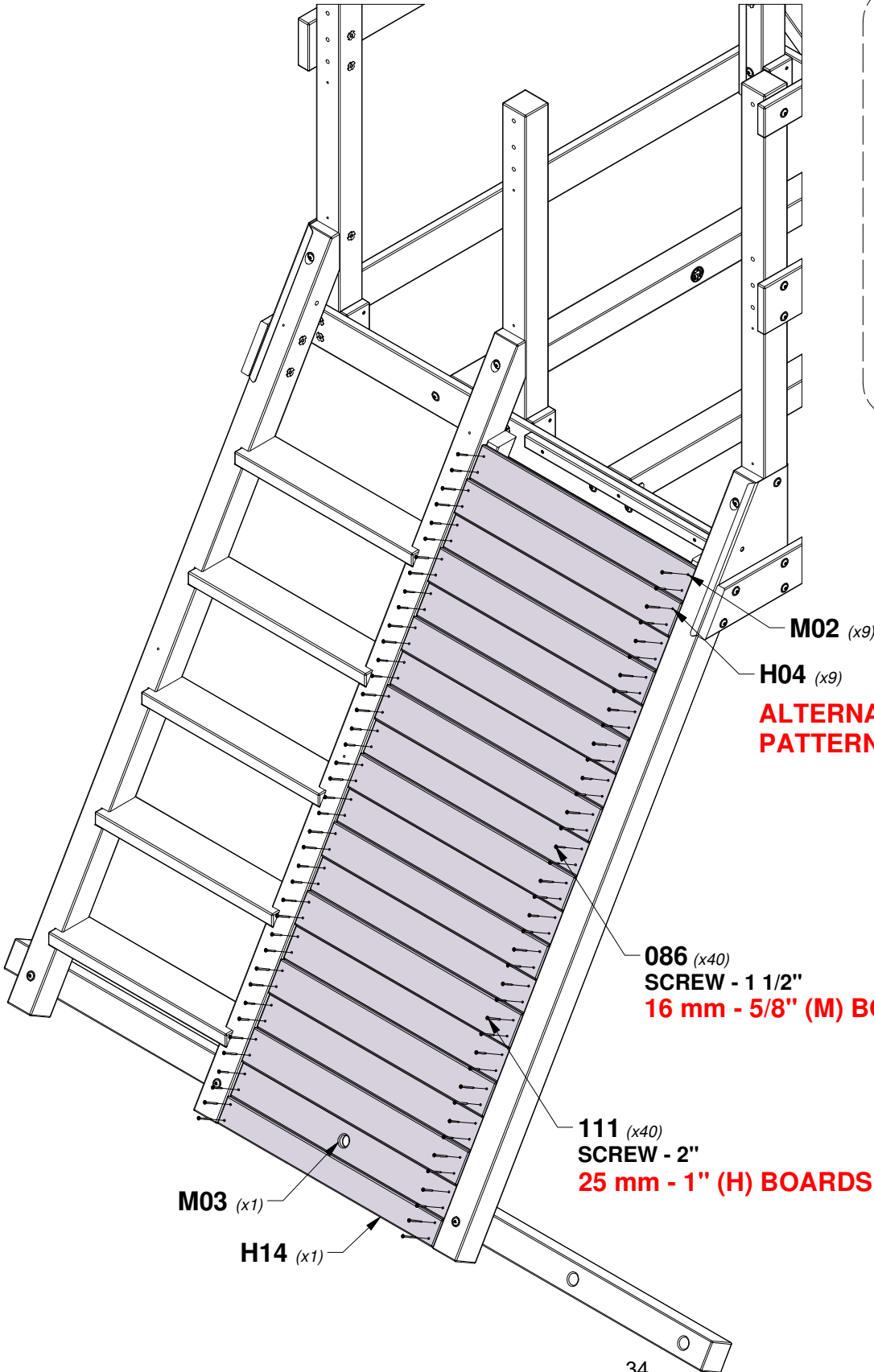

**ALTERNATE (M02) & (H04)
PATTERN AS YOU GO DOWN**

STEP 15B - FORT ASSEMBLY

QTY	PART NUMBER	DESCRIPTION
18	H100086	SCREW PFH 8x1-1/2"

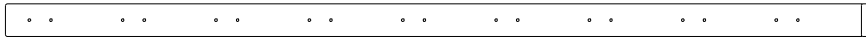

J02 | ROPE WALL CLEAT - W4L16469
(x1) | 1"x2 3/8"x63" (24x60x1600)

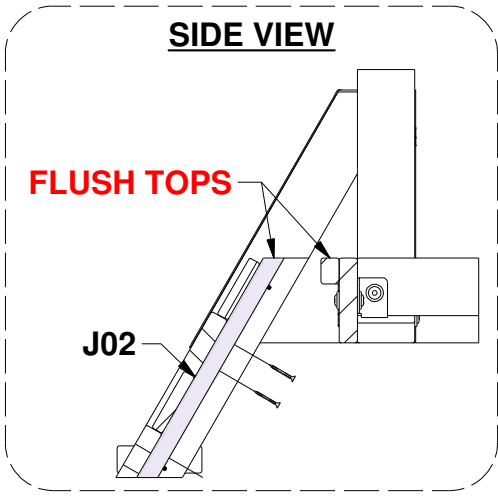

J02 (x1)
CENTER J02 ON ROPE WALL

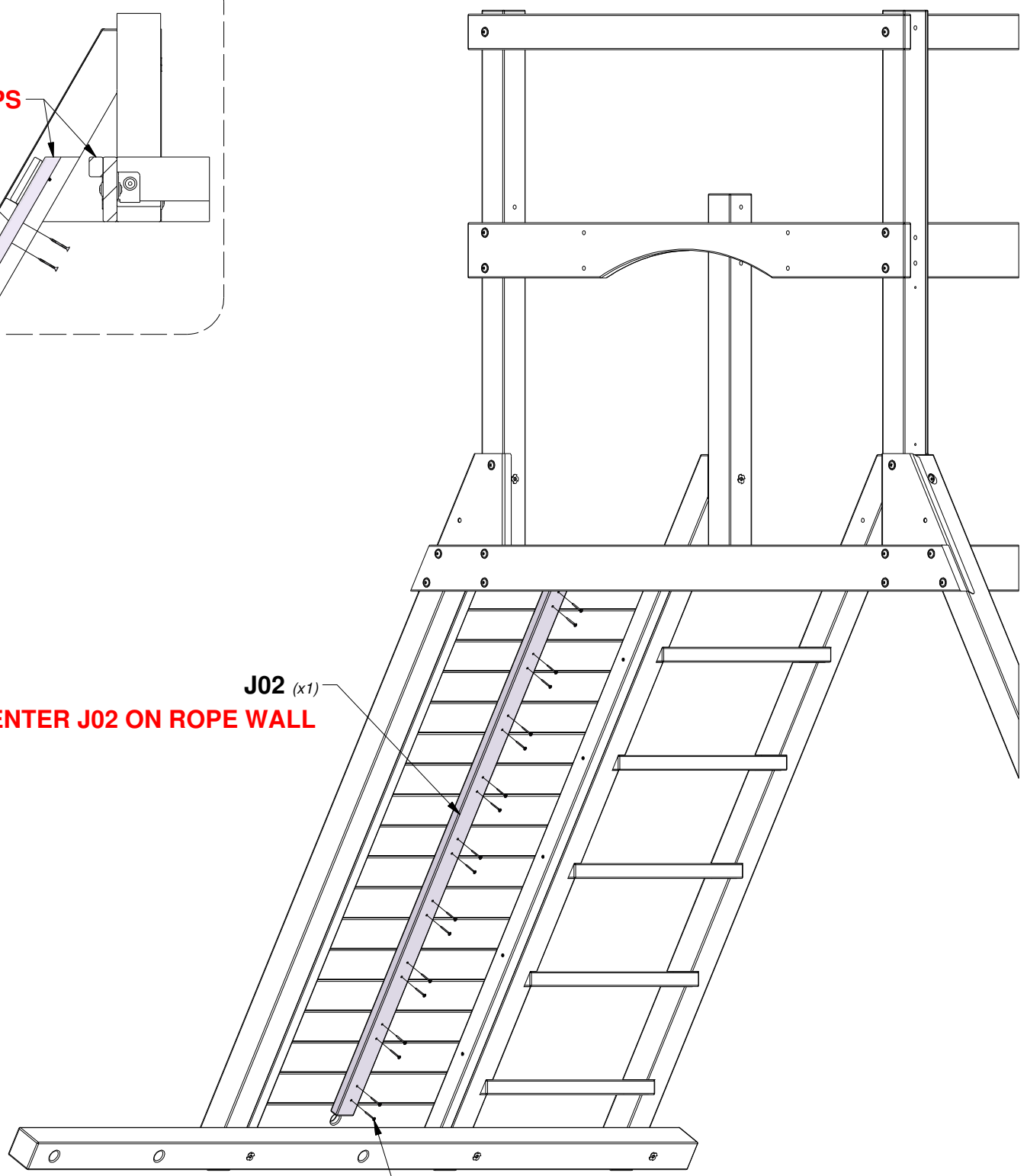

086 (x18)
SCREW - 1 1/2"

STEP 16 - FORT ASSEMBLY

QTY	PART NUMBER	DESCRIPTION
6	H100089	SCREW PFH 8x1-3/4"
14	H100092	SCREW PFH 8x3

T01 | CLEAT - W4L15748
(x2) | 1"x1 3/8"x24 1/4" (24x34x615)

F01 | CLEAT - W4L15746
(x2) | 1 3/8"x2"x68 3/4" (36x52x1747)

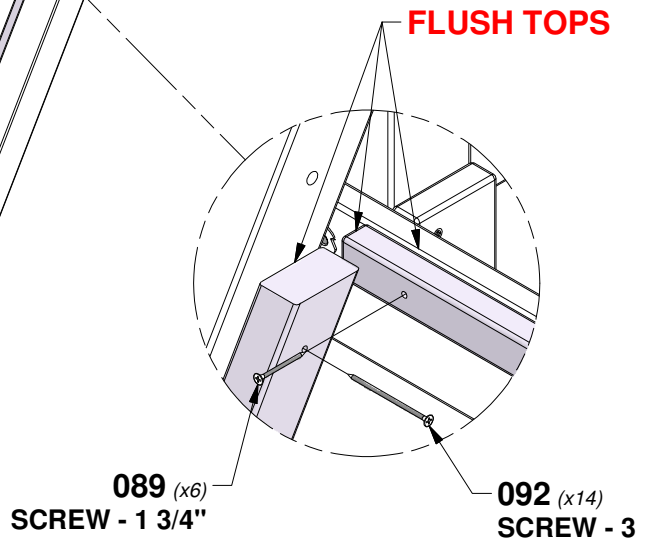
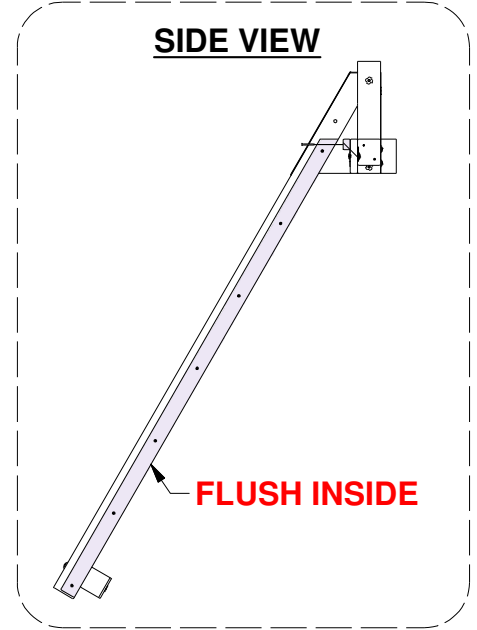
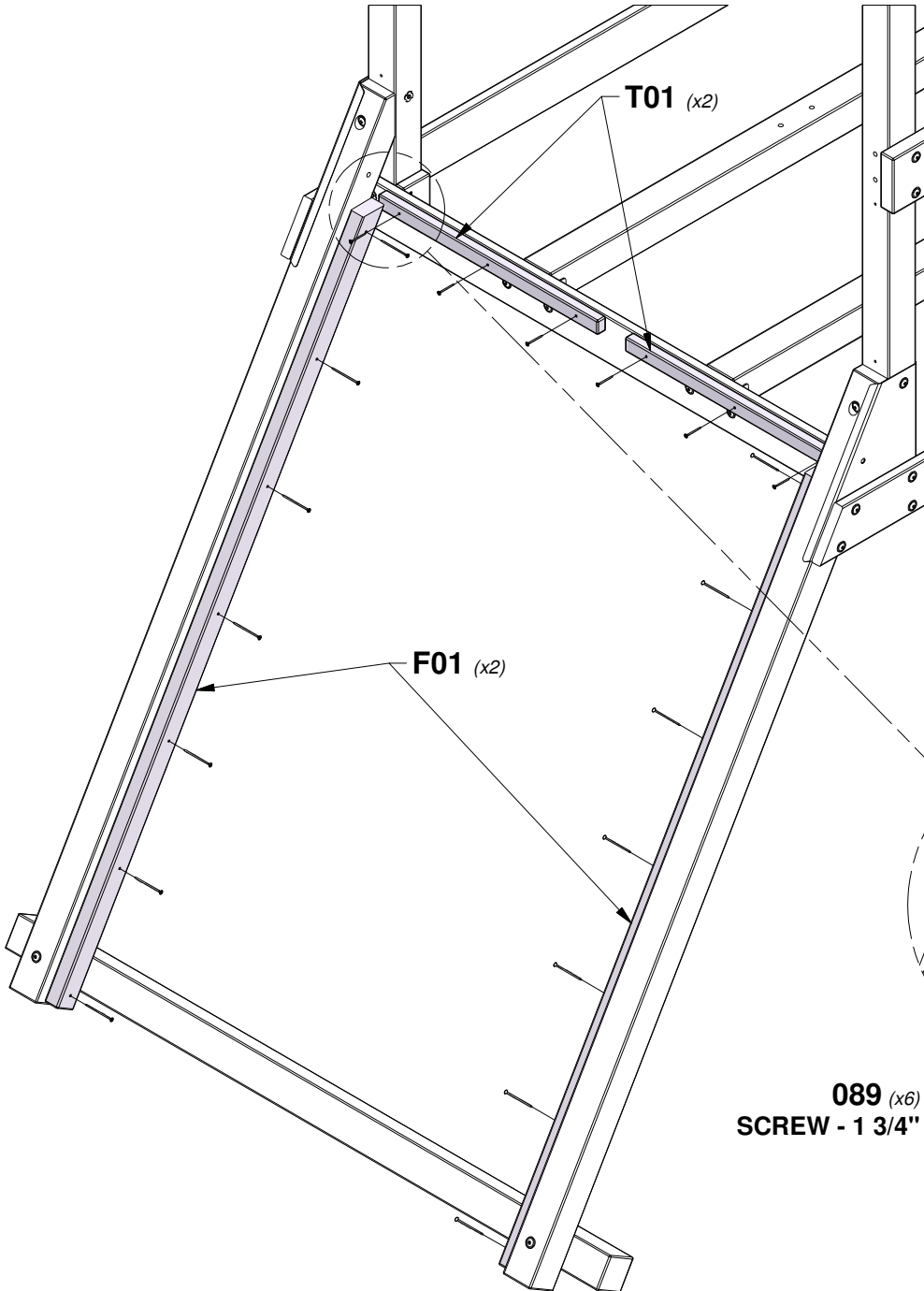

STEP 17A - FORT ASSEMBLY

QTY	PART NUMBER	DESCRIPTION
34	H100072	T-NUT 1/4
34	H100108	WASHER LOCK INT 8x15
34	H100137	BOLT WH 1/4x1

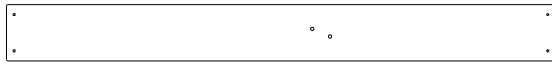

G05 | ROCK WALL BOARD - W4L15974
(x5) | 1"x5 1/4"x51 1/2" (24x134x1307)



G06 | ROCK WALL BOARD - W4L15975
(x6) | 1"x5 1/4"x51 1/2" (24x134x1307)



A6P00037 | GREEN HC ROCK
(x8) | #2



A6P00036 | GREEN HC ROCK
(x9) | #1

TIP:
INSTALL T-NUTS IN WOOD FIRST

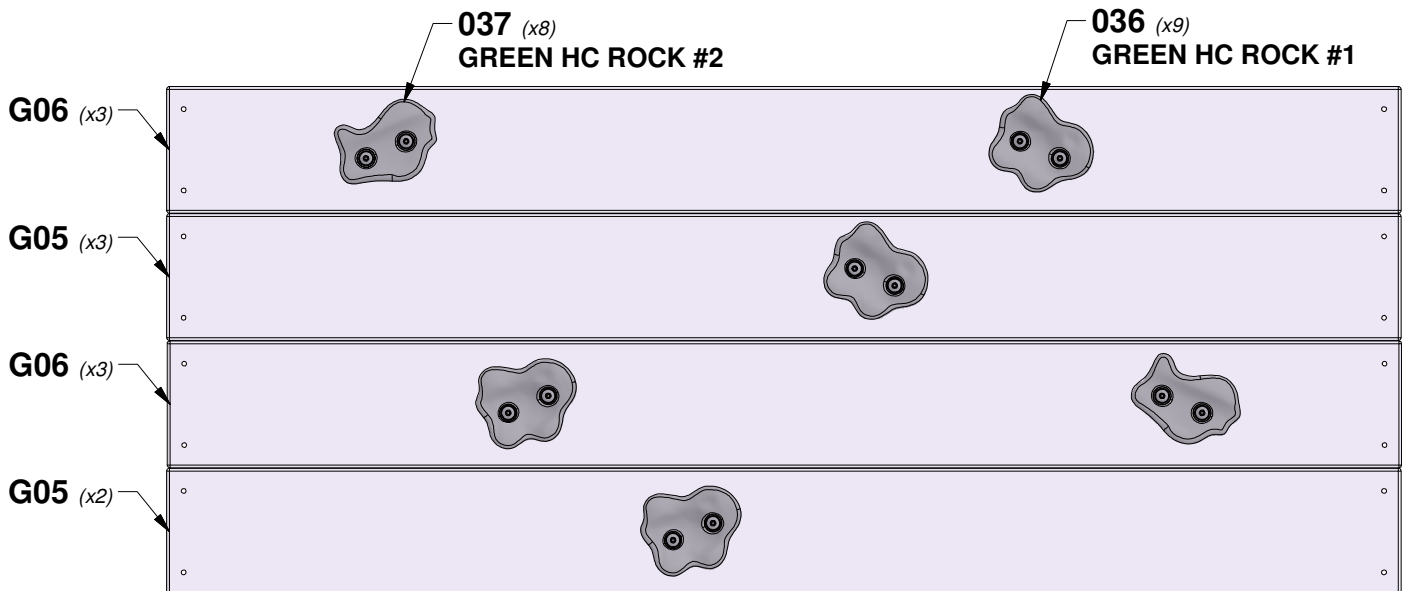
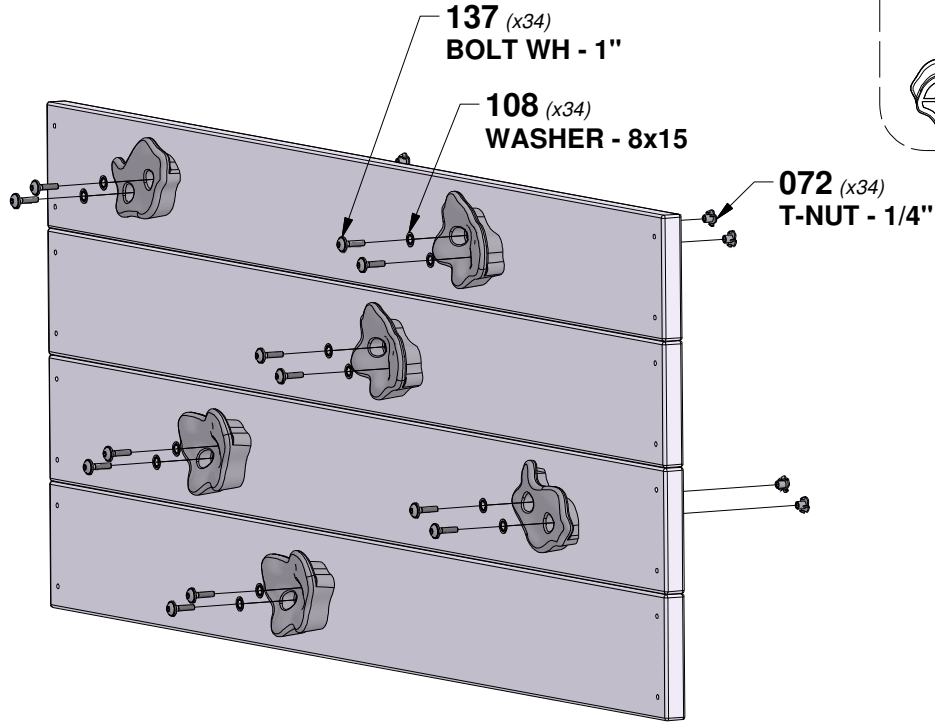
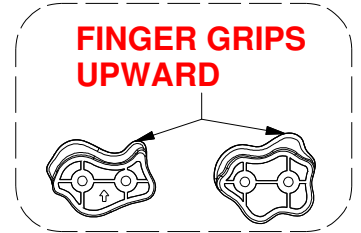

PLACE ROCKS RANDOMLY

STEP 17B - FORT ASSEMBLY

QTY	PART NUMBER	DESCRIPTION
52	H100111	SCREW PFH 8x2"



G04 | ROCK WALL BOARD - W4L15749
(x2) | 1"x4 1/2"x5 1/2" (24x115x1307)

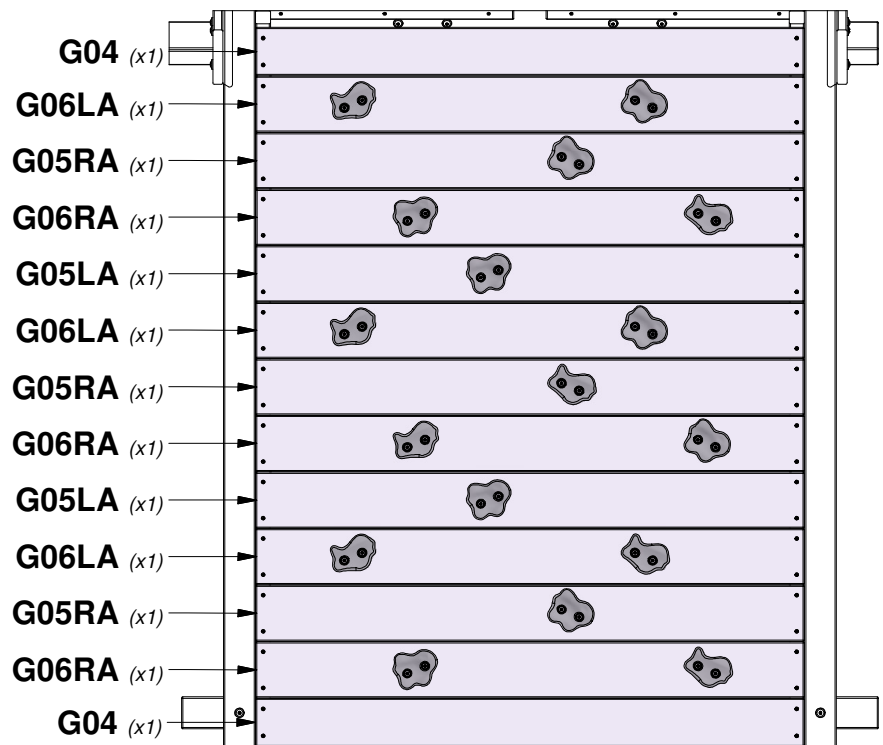
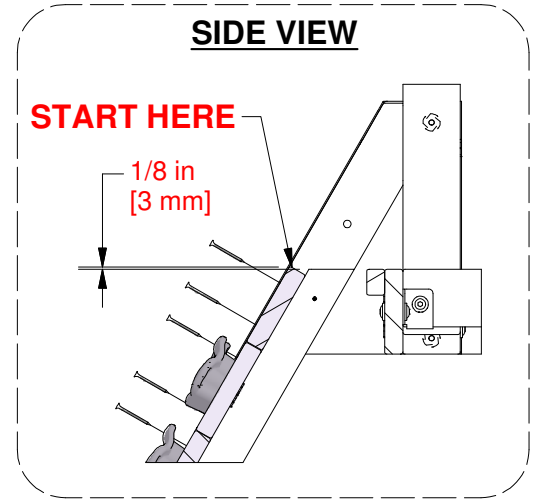
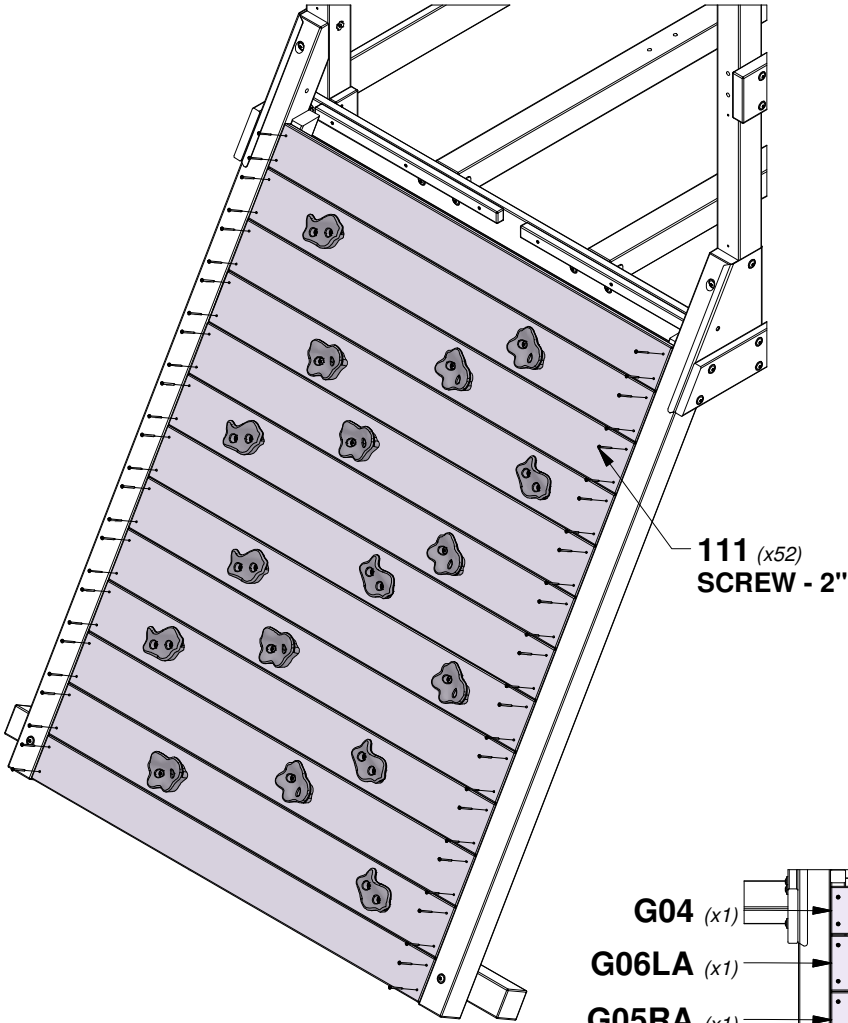
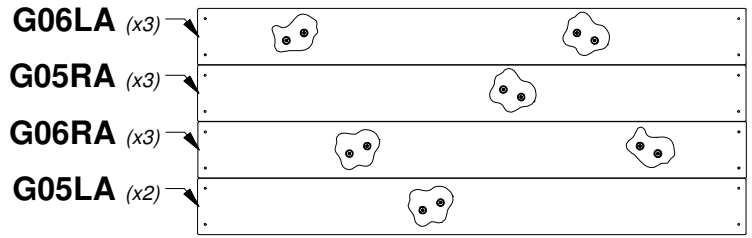

STEP 18 - FORT ASSEMBLY

QTY	PART NUMBER	DESCRIPTION
48	H100086	SCREW PFH 8x1-1/2"

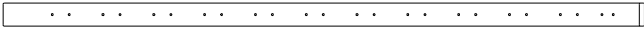

J01 | ROCK WALL CLEAT - W4L15977
 (x2) | 1"x2 3/8"x66 7/8" (24x60x1698)

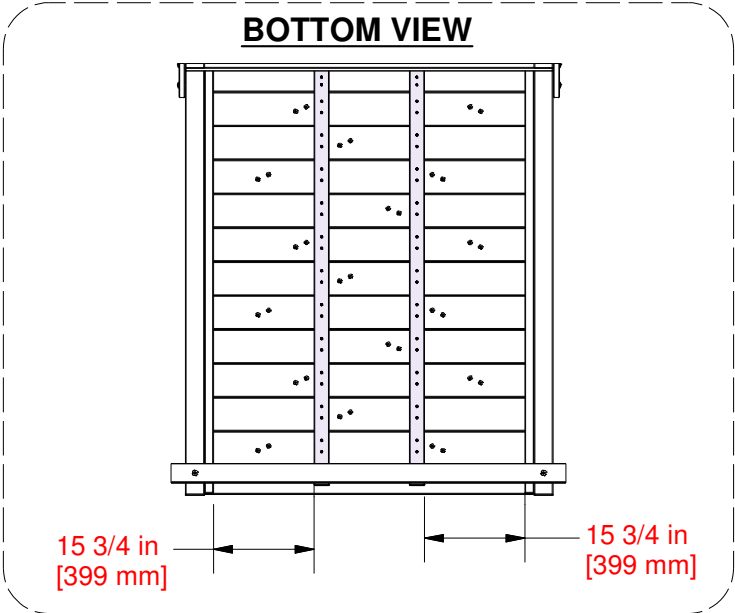
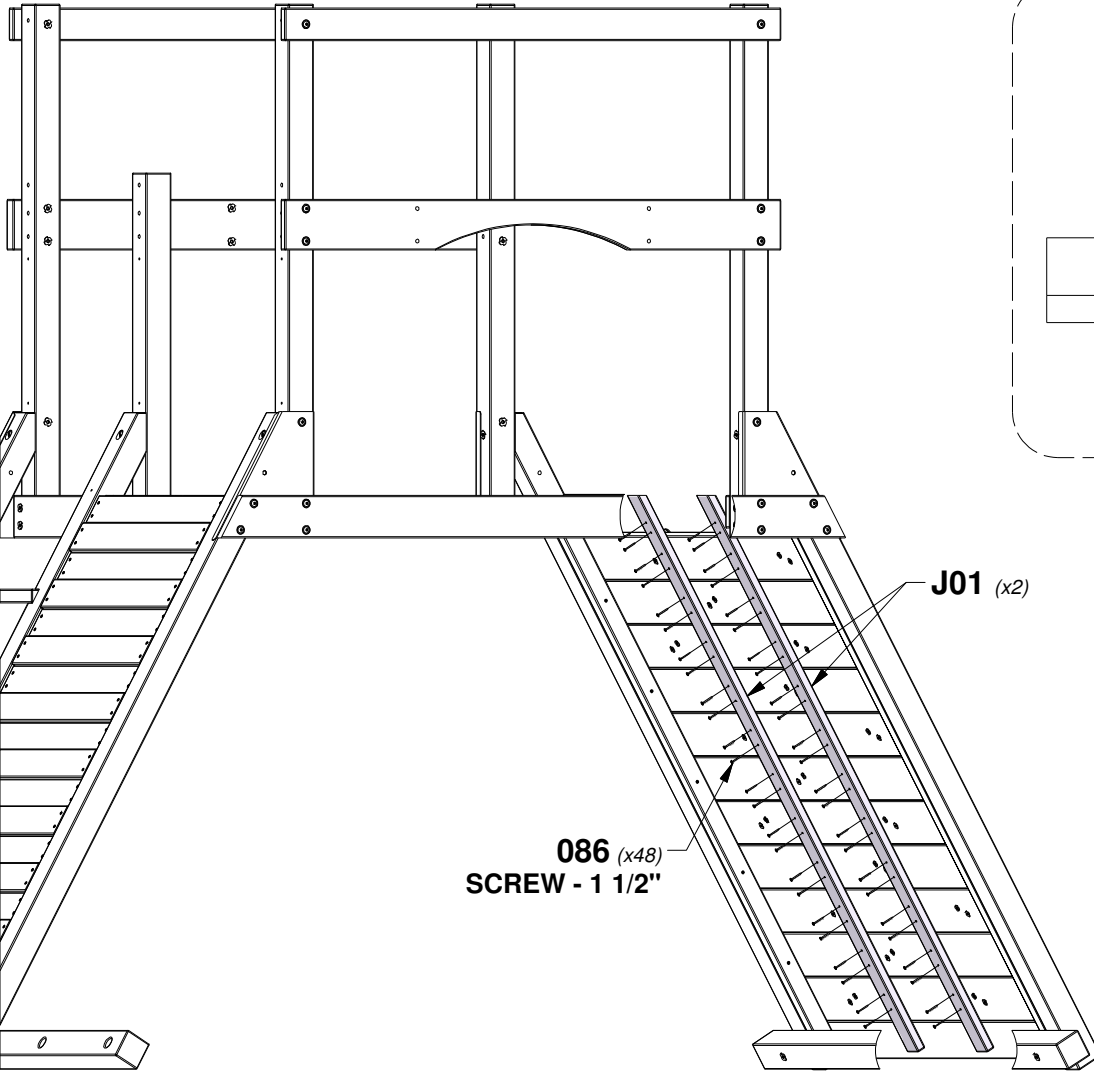
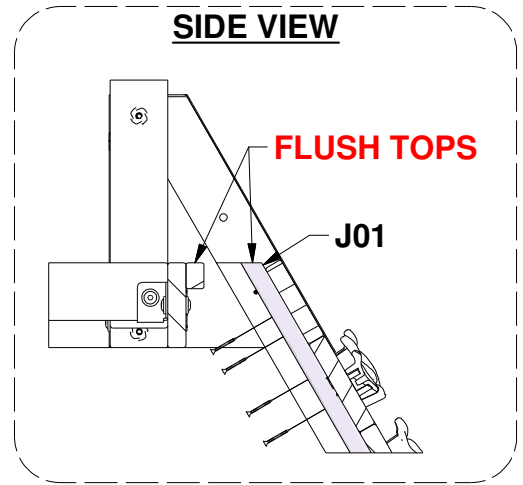

STEP 19A - FORT ASSEMBLY

QTY	PART NUMBER	DESCRIPTION
2	H100074	T-NUT 5/16



M01 | FLOOR BOARD - W4L15743
(x12) | 5/8"x3 3/8"x59 1/2" (16x86x1511)



Y01 | FLOOR BOARD - W4L15738
(x1) | 5/8"x4"x20 7/8" (16x102x529)



Y03 | FLOOR BOARD - W4L16468
(x1) | 5/8"x4"x27 5/8" (16x102x701)



Y02 | FLOOR BOARD - W4L15745
(x1) | 5/8"x4"x51 1/2" (16x102x1307)

TIP:
INSTALL T-NUTS IN WOOD FIRST

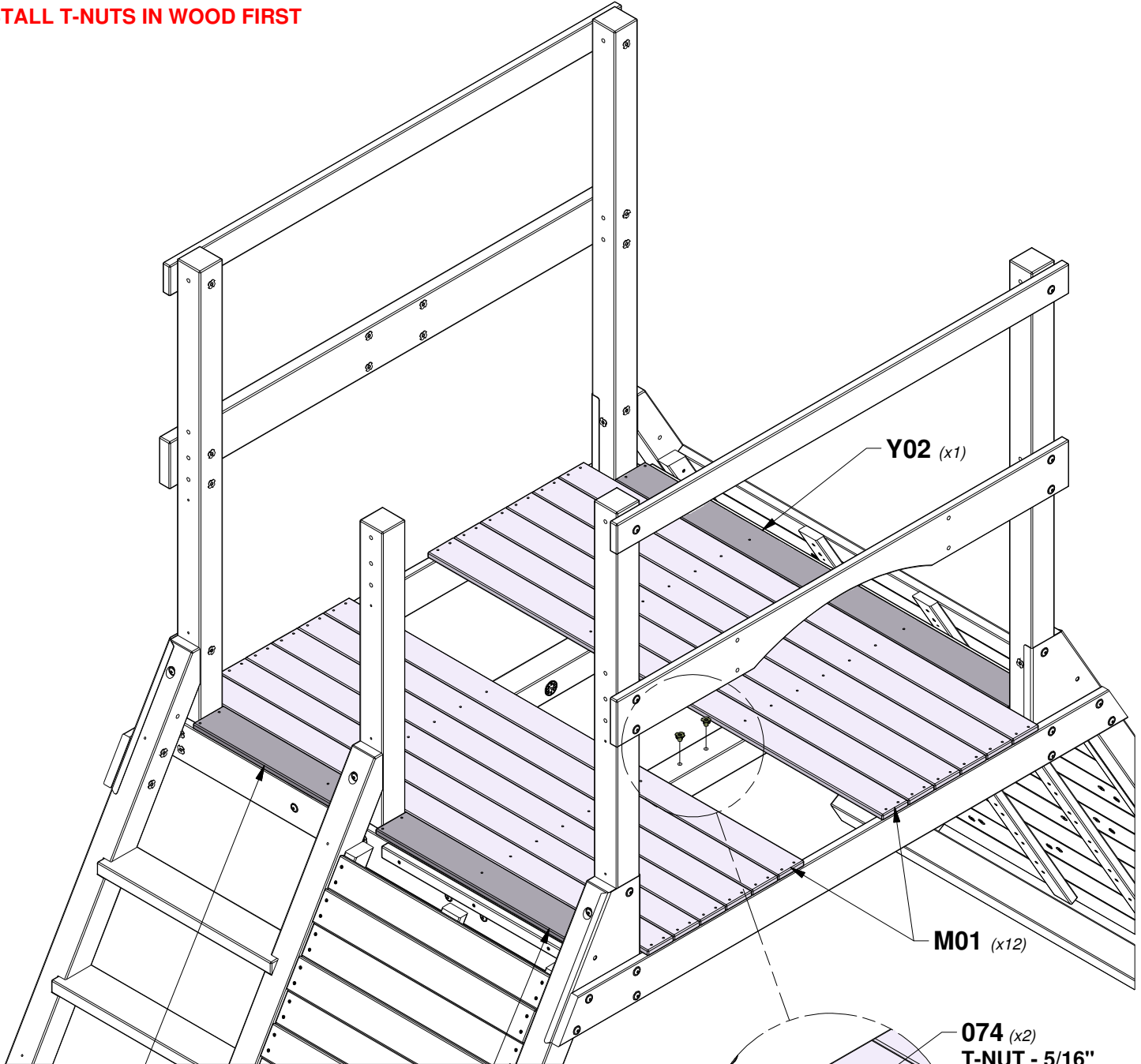

Y02 (x1)

M01 (x12)

074 (x2)
T-NUT - 5/16"

Y01 (x1)

Y03 (x1)

**DO NOT FASTEN DOWN
FLOOR BOARDS AT THIS TIME.**

STEP 19B - FORT ASSEMBLY

QTY	PART NUMBER	DESCRIPTION
106	H100086	SCREW PFH 8x1-1/2"



M01 FLOOR BOARD - W4L15743
(x3) 5/8"x3 3/8"x59 1/2" (16x86x1511)

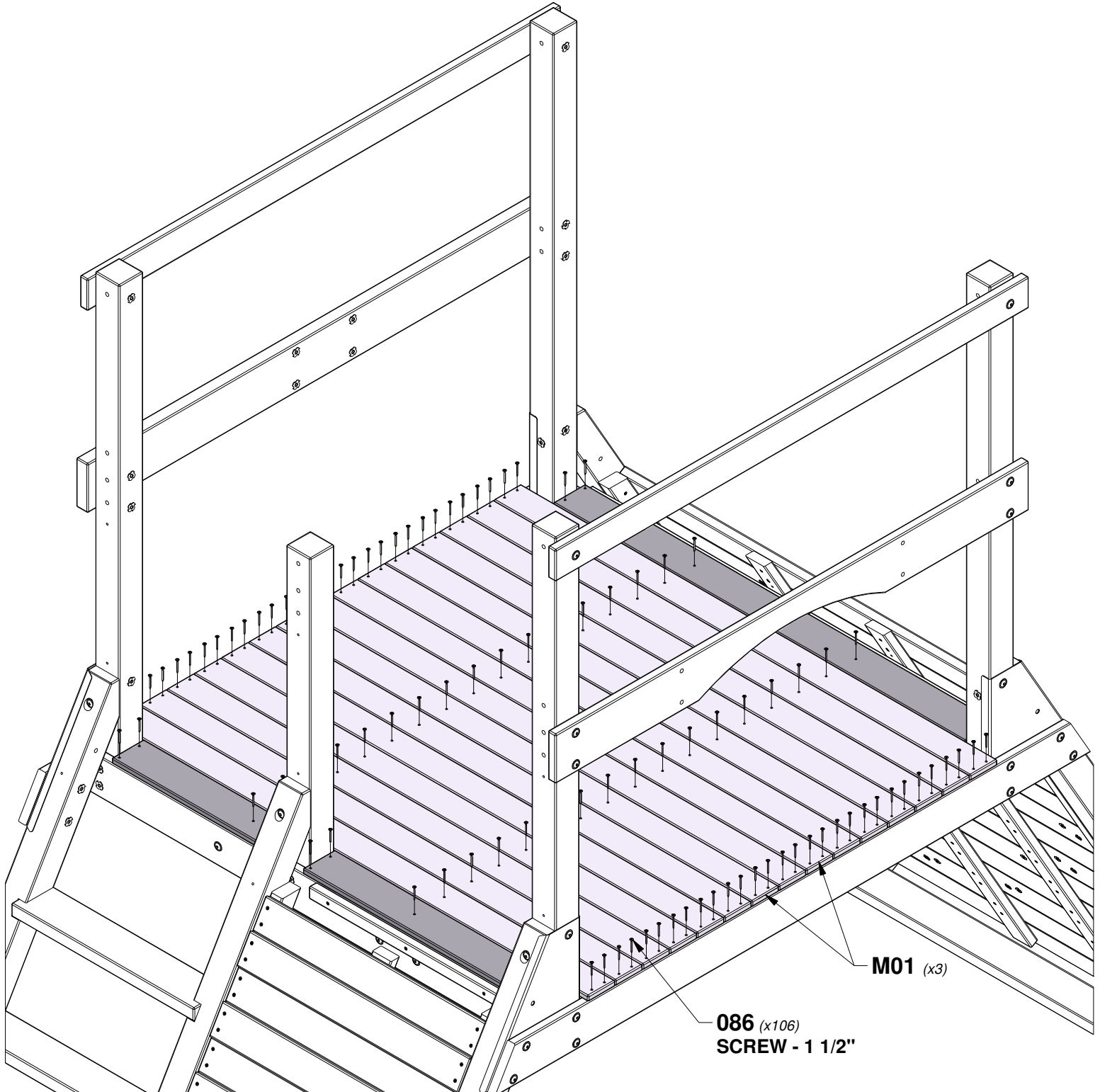

STEP 20 - FORT ASSEMBLY

QTY	PART NUMBER	DESCRIPTION
12	H100086	SCREW PFH 8x1-1/2"

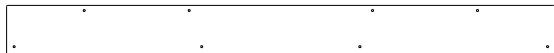

K04 FLOOR BOARD - W4L15978
(x1) | 5/8"x4 3/4"x51 1/2" (16x120x1307)



K05 FLOOR BOARD - W4L15979
(x1) | 5/8"x4 3/4"x27 5/8" (16x120x701)

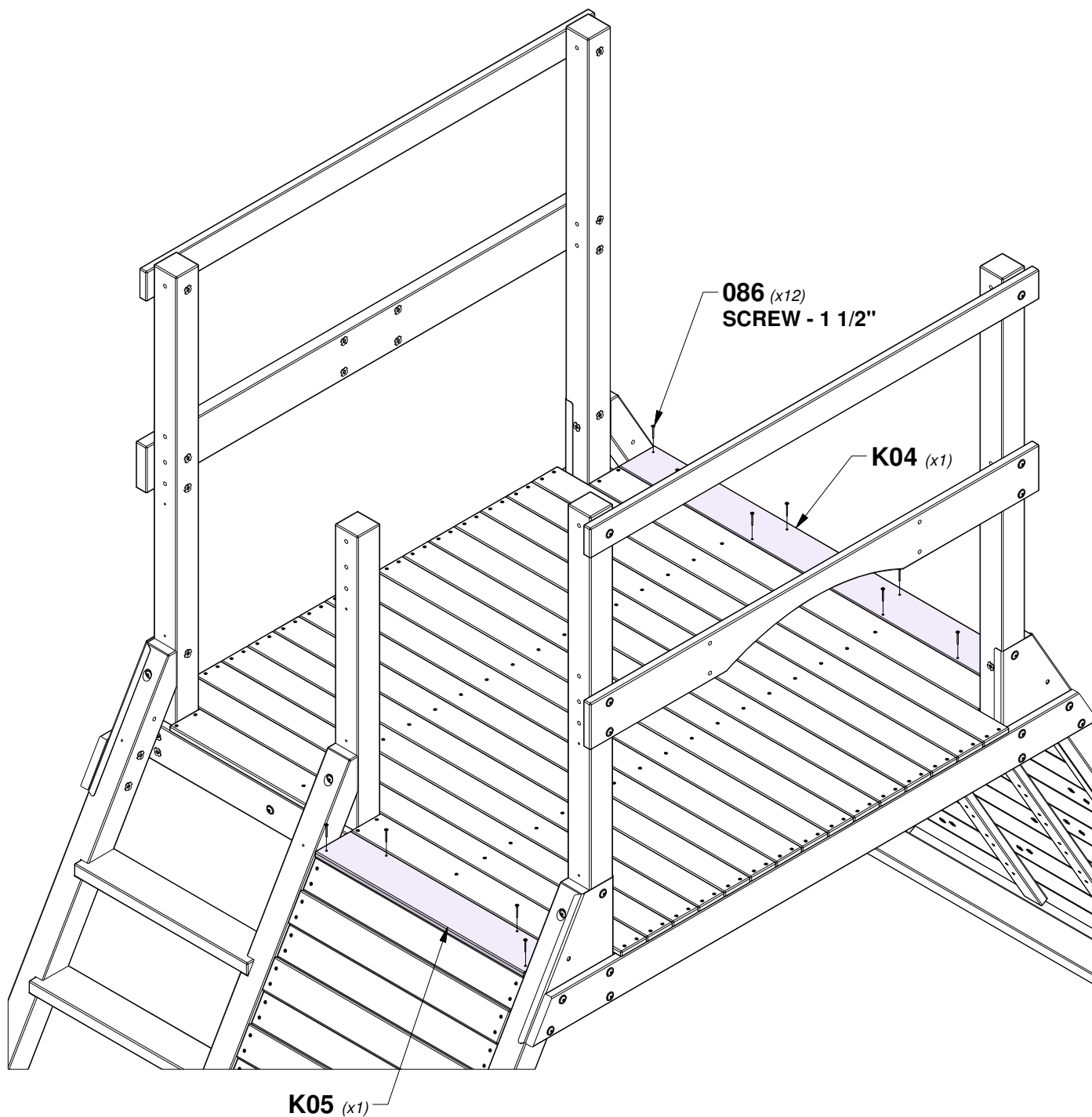

STEP 21 - FORT ASSEMBLY

QTY	PART NUMBER	DESCRIPTION
4	H100019	BOLT WH 5/16x3 3/4
4	H100030	WASHER LOCK EXT 8x19
4	H100074	T-NUT 5/16



H01 | FLOOR RAIL - W4L15734
(x1) | 1"x3 3/8"x68 1/2" (24x86x1741)



H02 | FLOOR RAIL - W4L15735
(x2) | 1"x3 3/8"x22 1/8" (24x86x564)

TIP:
INSTALL T-NUTS IN WOOD FIRST

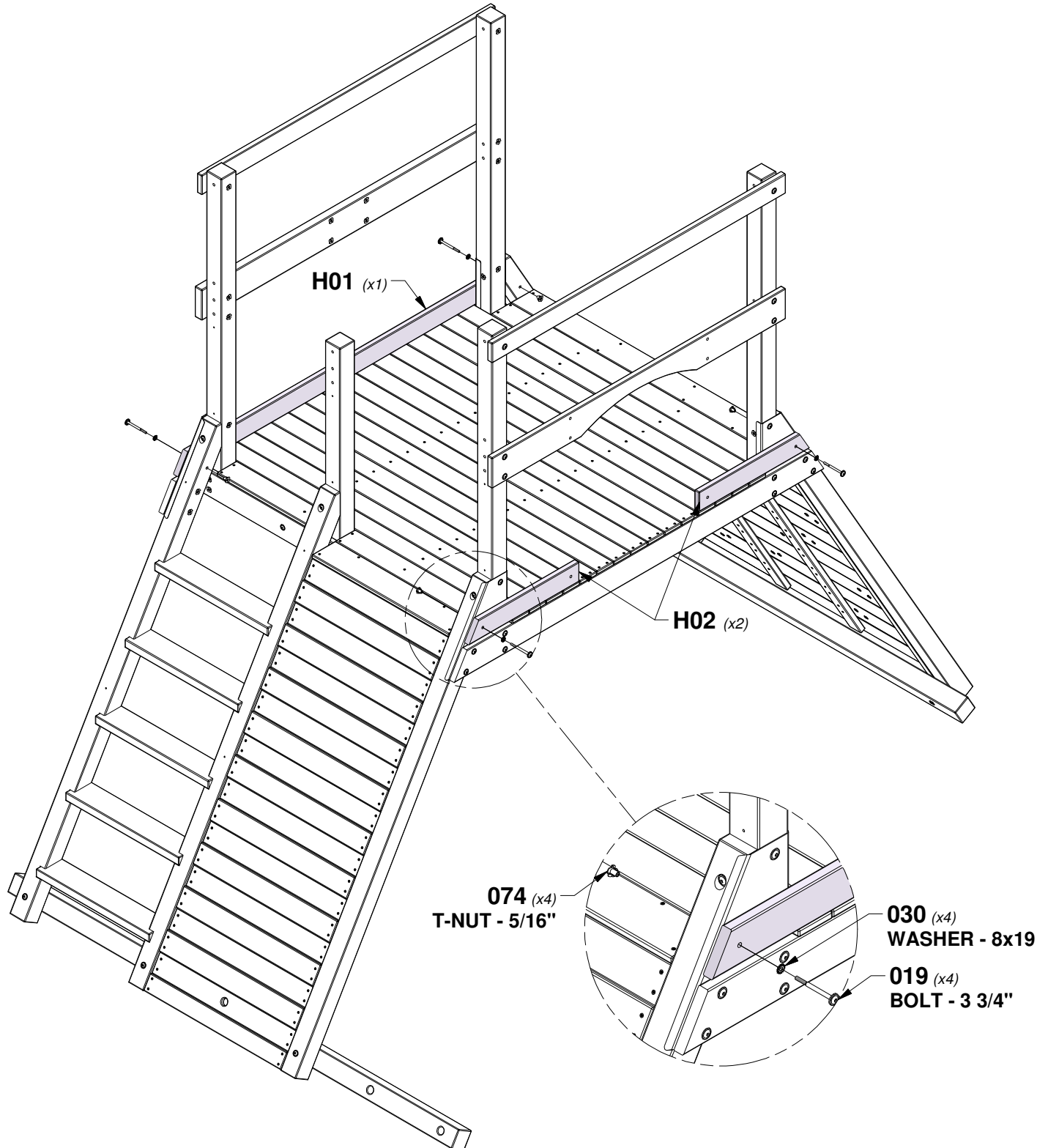

STEP 22 - FORT ASSEMBLY



H05 | WALL RAIL - W4L15980
(x2) | 1"x3 3/8"x29 7/8" (24x86x760)



A4M01047 | L BRACKET
(x2) | 2.5x38x55x55

QTY	PART NUMBER	DESCRIPTION
2	H100005	NUT BARREL WH 5/16x7/8
4	H100011	BOLT WH 5/16x1 3/4
4	H100030	WASHER LOCK EXT 8x19
2	H100031	WASHER LOCK EXT 12x19
4	H100074	T-NUT 5/16
2	H100379	T-NUT 5/16 BLK
2	H100396	BOLT WH 5/16x1/2 BLK
2	H100407	BOLT WH 5/16x1 1/2 BLK

TIP:
INSTALL T-NUTS IN WOOD FIRST

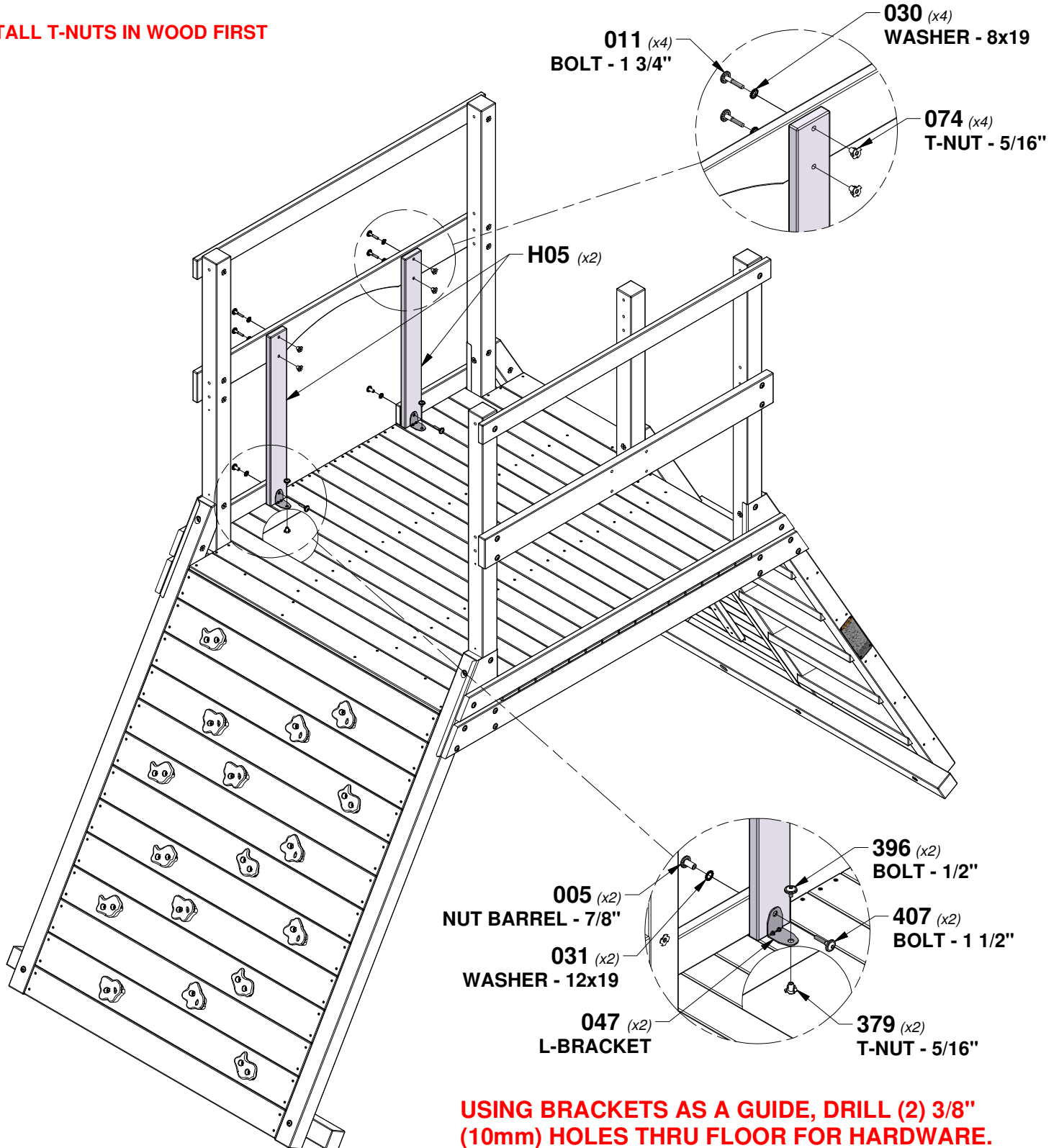

USING BRACKETS AS A GUIDE, DRILL (2) 3/8" (10mm) HOLES THRU FLOOR FOR HARDWARE.

STEP 23 - FORT ASSEMBLY

QTY	PART NUMBER	DESCRIPTION
4	H100019	BOLT WH 5/16x3 3/4
4	H100030	WASHER LOCK EXT 8x19
4	H100074	T-NUT 5/16

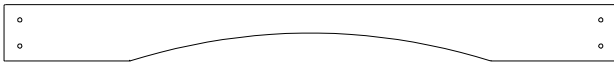

G03 | WALL RAIL - W4L15727
(x1) 1"x5 1/4"x57 1/2" (24x134x1460)

TIP:
INSTALL T-NUTS IN WOOD FIRST

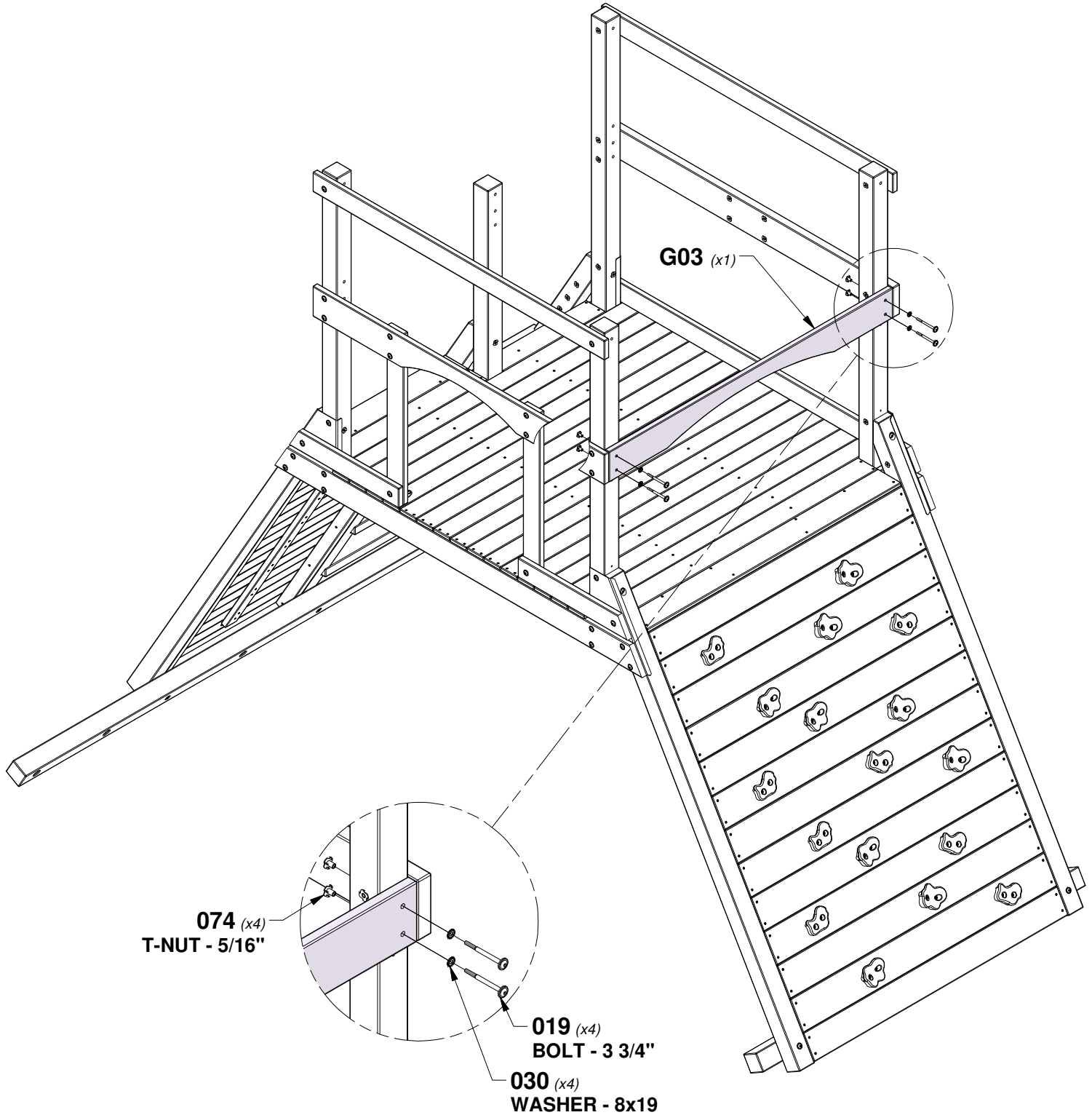

STEP 24 - FORT ASSEMBLY

QTY	PART NUMBER	DESCRIPTION
6	H100019	BOLT WH 5/16x3 3/4
6	H100030	WASHER LOCK EXT 8x19
6	H100074	T-NUT 5/16

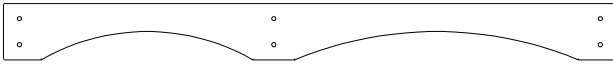

G01 | WALL RAIL - W4L15725
(x1) | 1"x5 1/4"x57 1/2" (24x134x1460)

TIP:
INSTALL T-NUTS IN WOOD FIRST

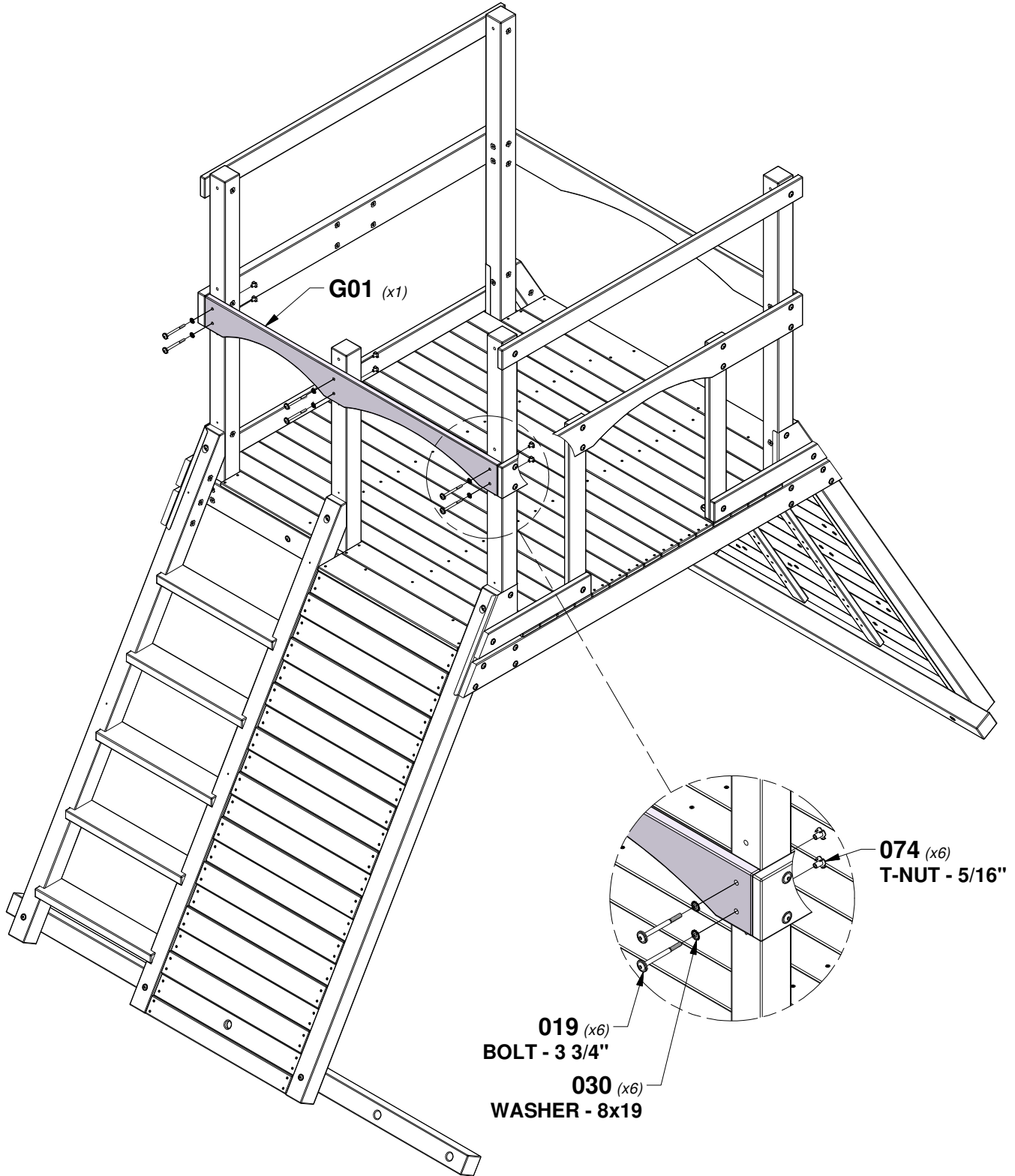

STEP 25 - FORT ASSEMBLY

QTY	PART NUMBER	DESCRIPTION
3	H100023	BOLT WH 5/16X6
3	H100030	WASHER LOCK EXT 8x19
3	H100074	T-NUT 5/16

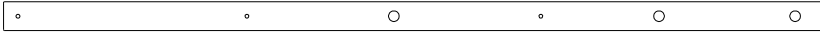

B09 | ROPE BOARD - W4L15740
(x1) | 3"x3"x85 3/8" (76x76x2170)

TIP:
INSTALL T-NUTS IN WOOD FIRST

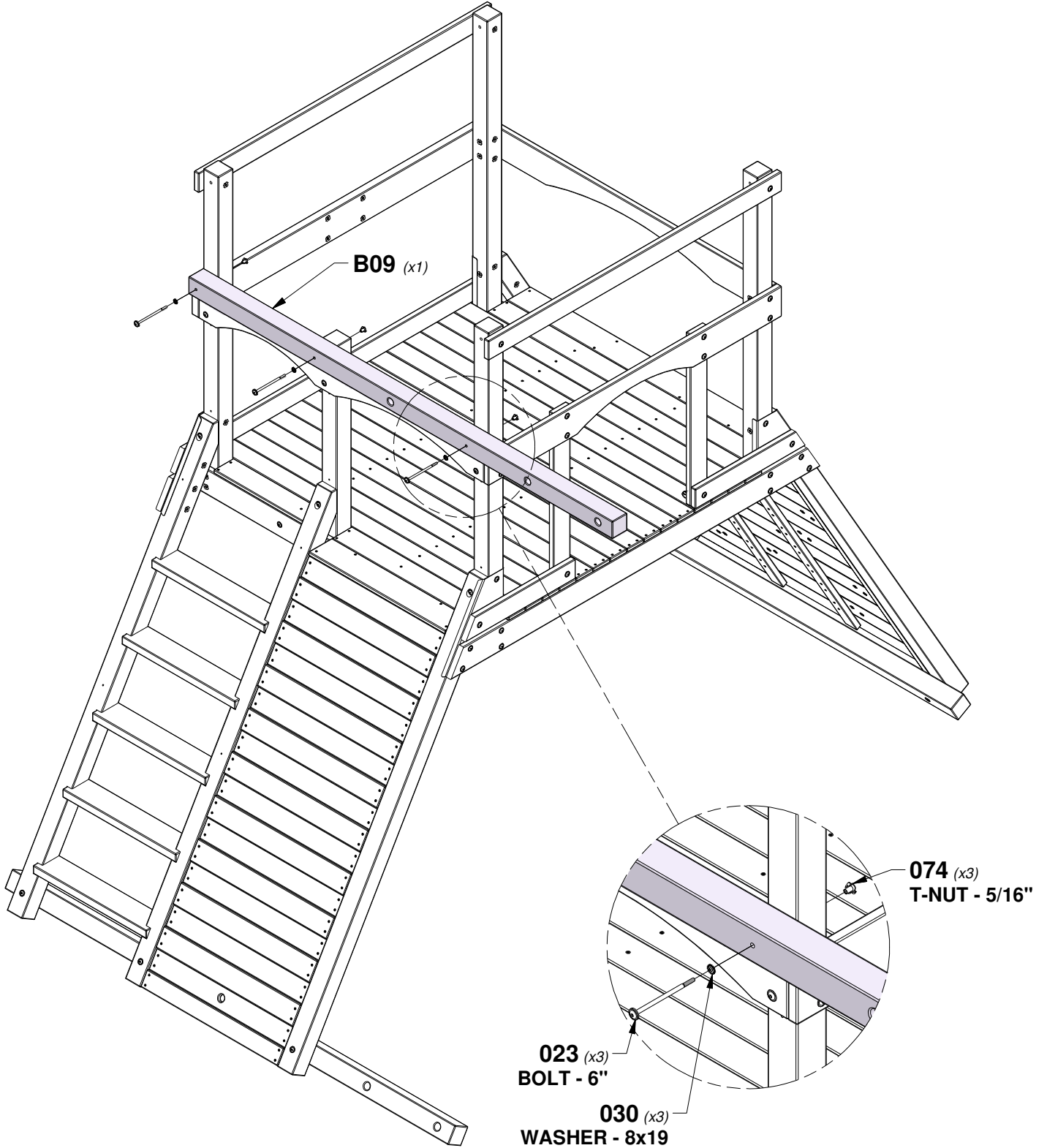

STEP 26 - FORT ASSEMBLY

QTY	PART NUMBER	DESCRIPTION
8	H100086	SCREW PFH 8x1-1/2"



M04 PICKET - W4L15997
(x2) 5/8"x3 3/8"x29 7/8" (16x86x760)

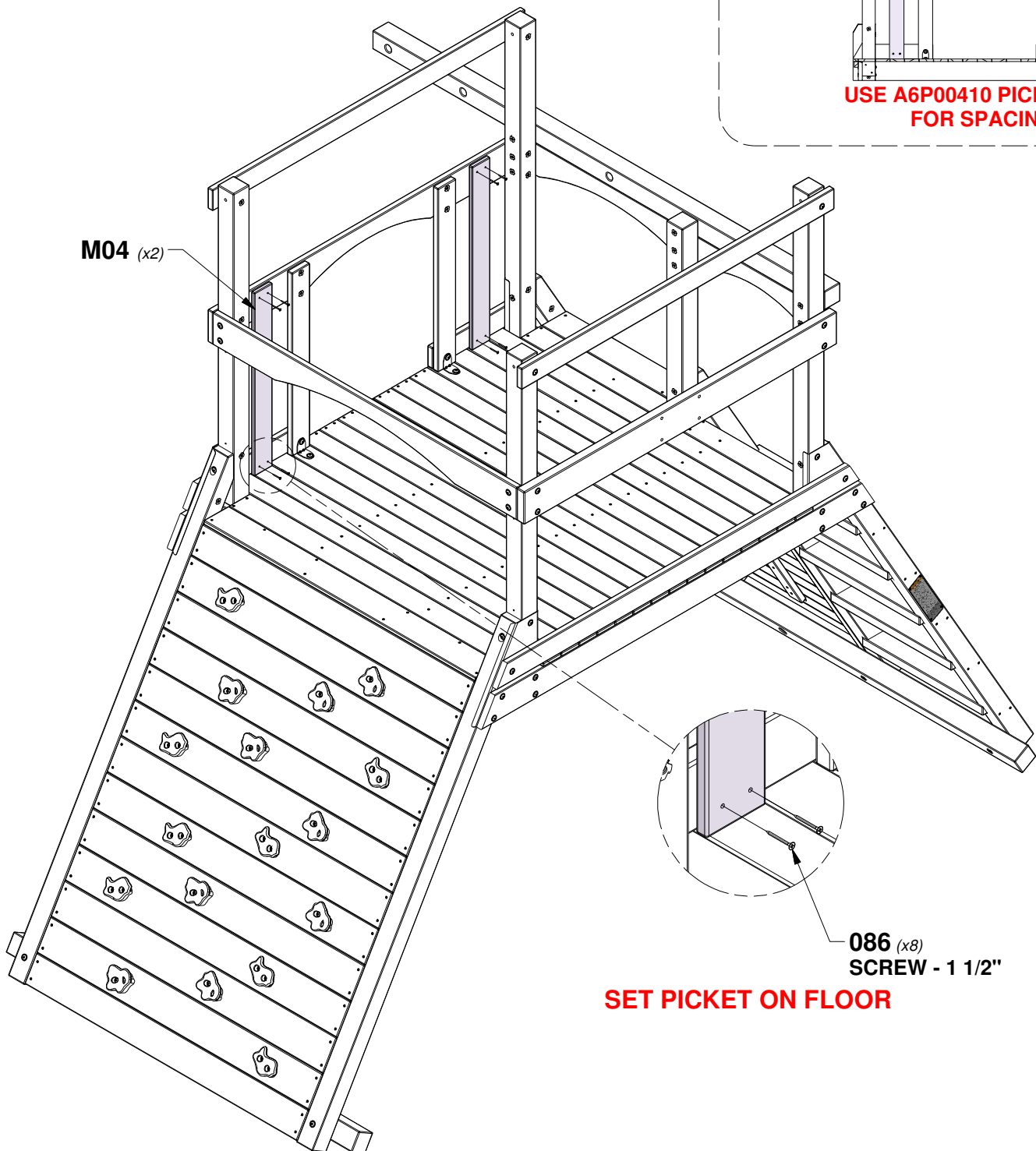
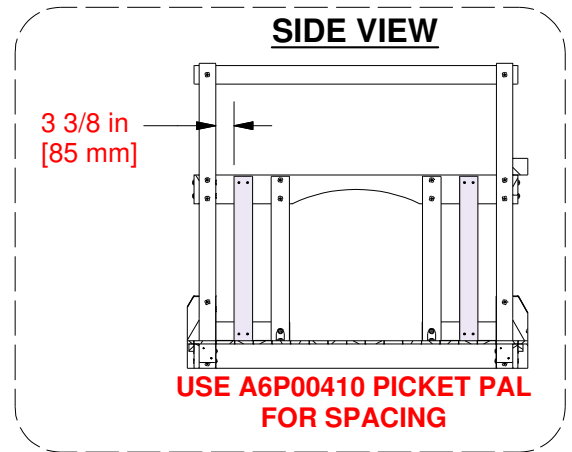

STEP 27 - FORT ASSEMBLY

QTY	PART NUMBER	DESCRIPTION
32	H100086	SCREW PFH 8x1-1/2"

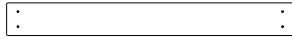

M04 PICKET - W4L15997
(x8) 5/8"x3 3/8"x29 7/8" (16x86x760)

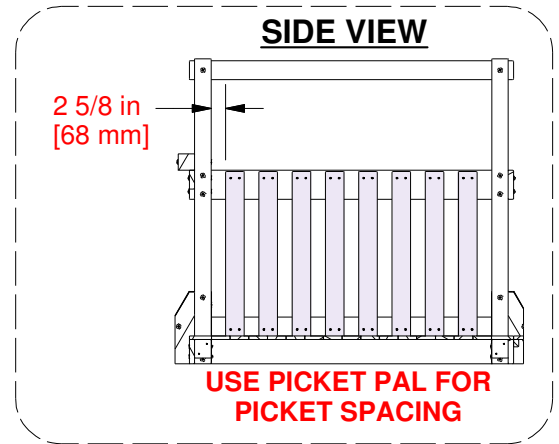

M04 (x8)

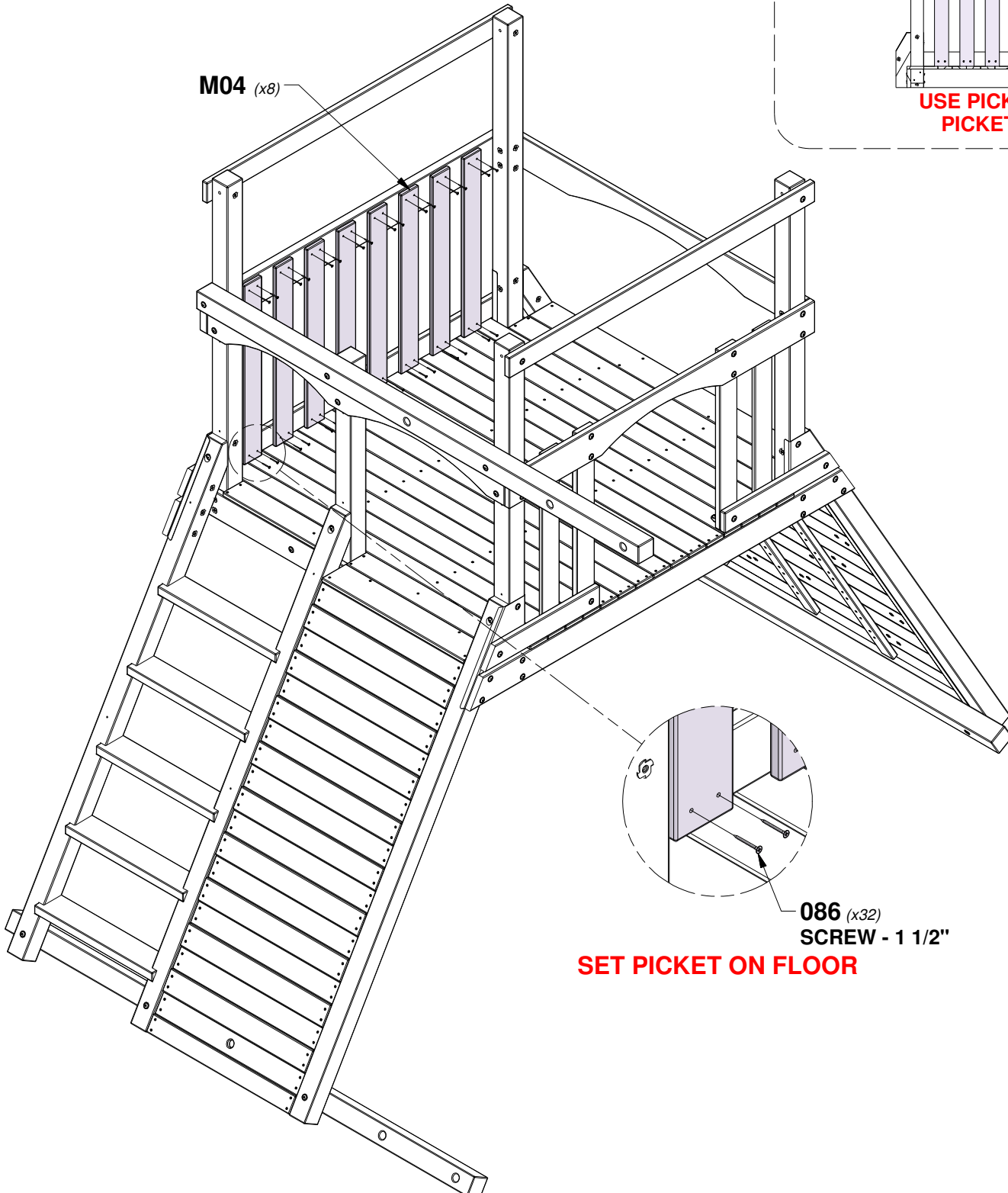

086 (x32)
SCREW - 1 1/2"

SET PICKET ON FLOOR

STEP 28 - FORT ASSEMBLY

QTY	PART NUMBER	DESCRIPTION
4	H100030	WASHER LOCK EXT 8x19
4	H100074	T-NUT 5/16
4	H100505	BOLT WH 5/16x4 3/4



H07 | WALL RAIL - W4L15983
(x2) | 1"x3 3/8"x57 1/2" (24x86x1460)

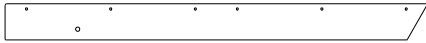

H09 | ROOF RAIL - W4L15985
(x4) | 1"x3 3/8"x39 5/8" (24x86x1007)

TIP:
INSTALL T-NUTS IN WOOD FIRST

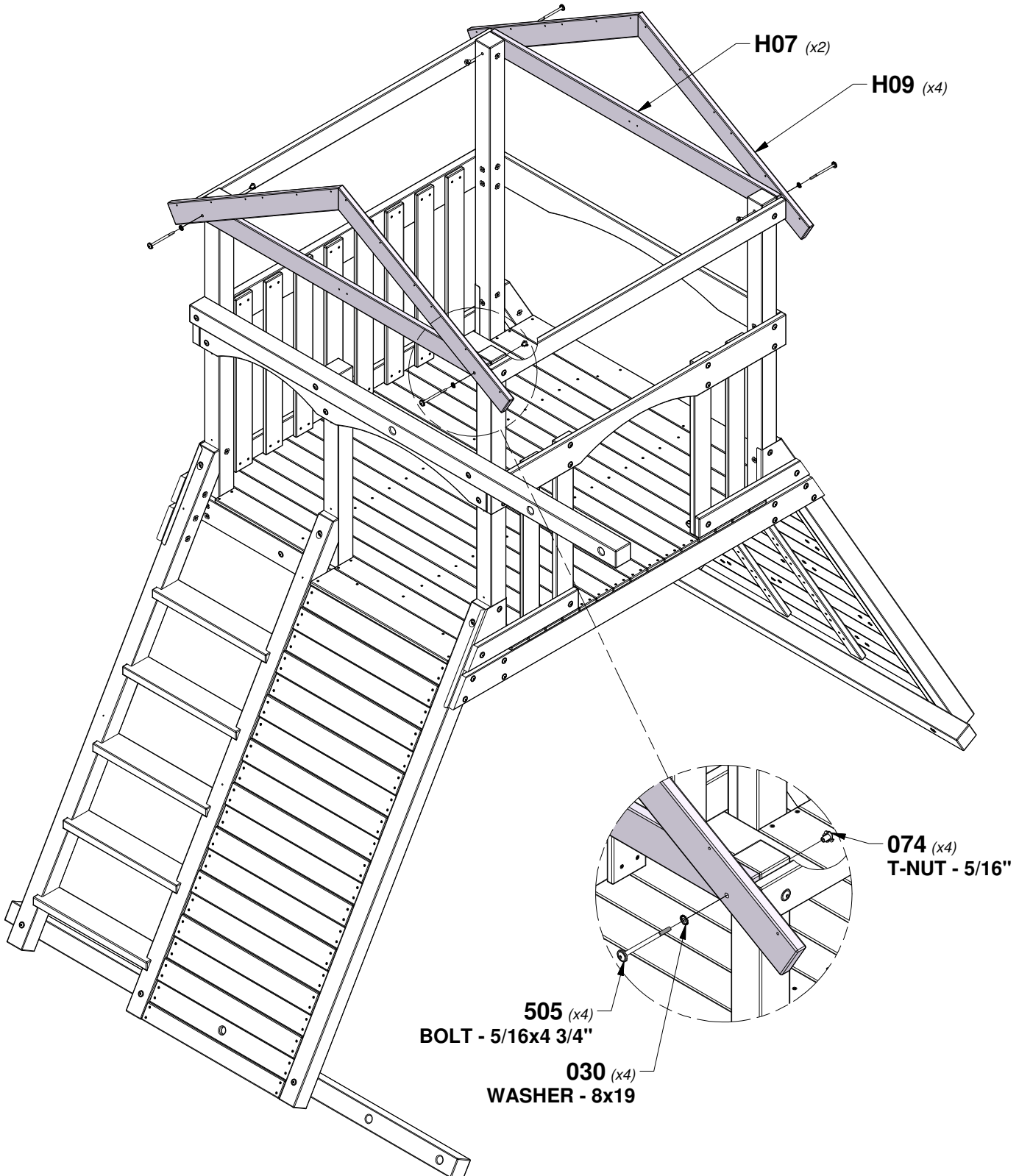

STEP 29 - FORT ASSEMBLY

QTY	PART NUMBER	DESCRIPTION
12	H100089	SCREW PFH 8x1-3/4"



H10 | GABLE BOARD - W4L15986
(x2) | 1"x3 3/8"x17 3/8" (24x86x440)



H11 | GABLE CLEAT - W4L15987
(x2) | 1"x3"x3 3/8" (24x76x86)

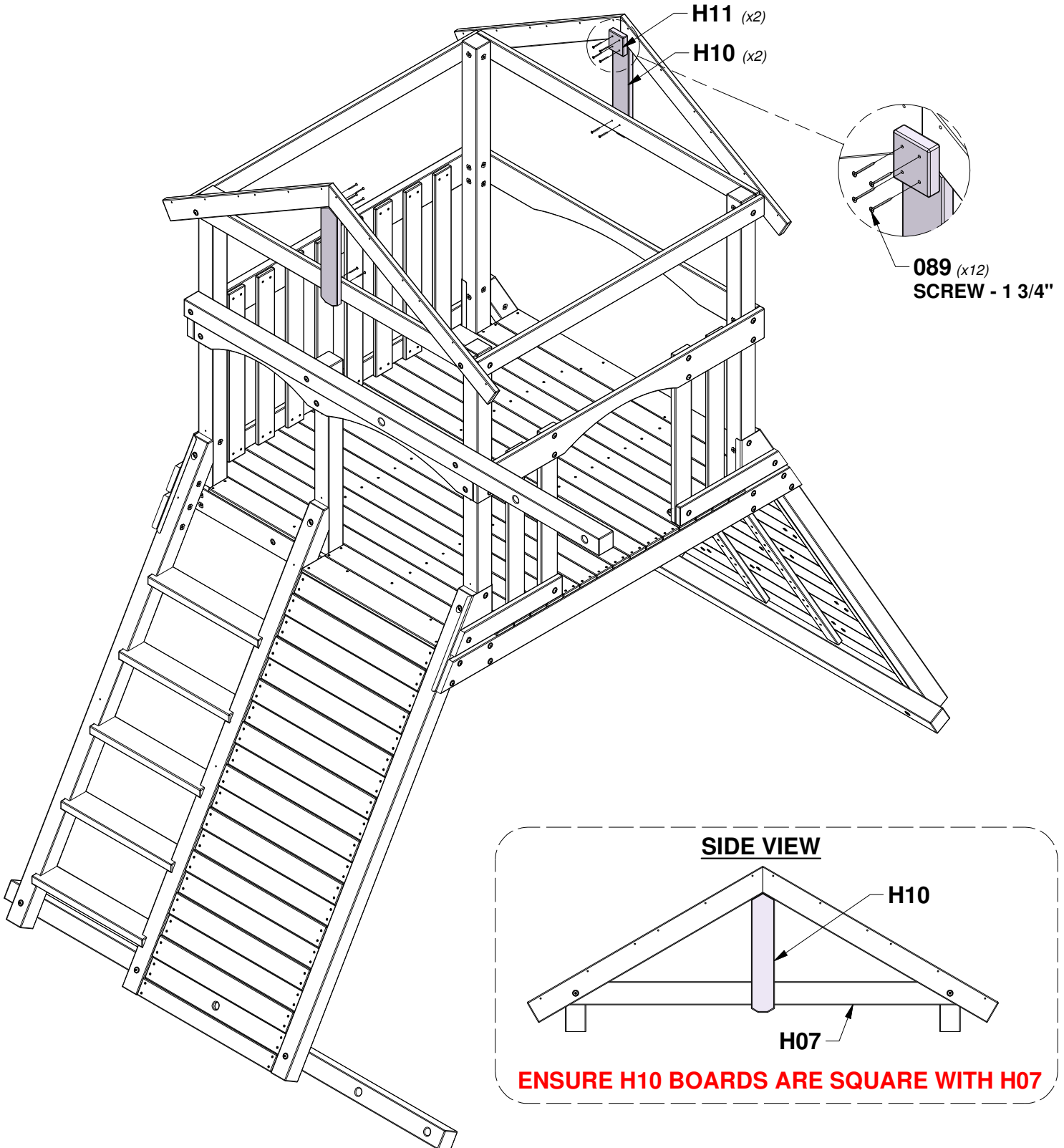

STEP 30 - FORT ASSEMBLY

QTY	PART NUMBER	DESCRIPTION
24	H100089	SCREW PFH 8x1-3/4"



H12 | GABLE BOARD - W4L15988
(x4) | 1"x3 3/8"x18 1/4" (24x86x465)



H13 | GABLE BOARD - W4L15989
(x4) | 1"x3 3/8"x11 3/4" (24x86x300)

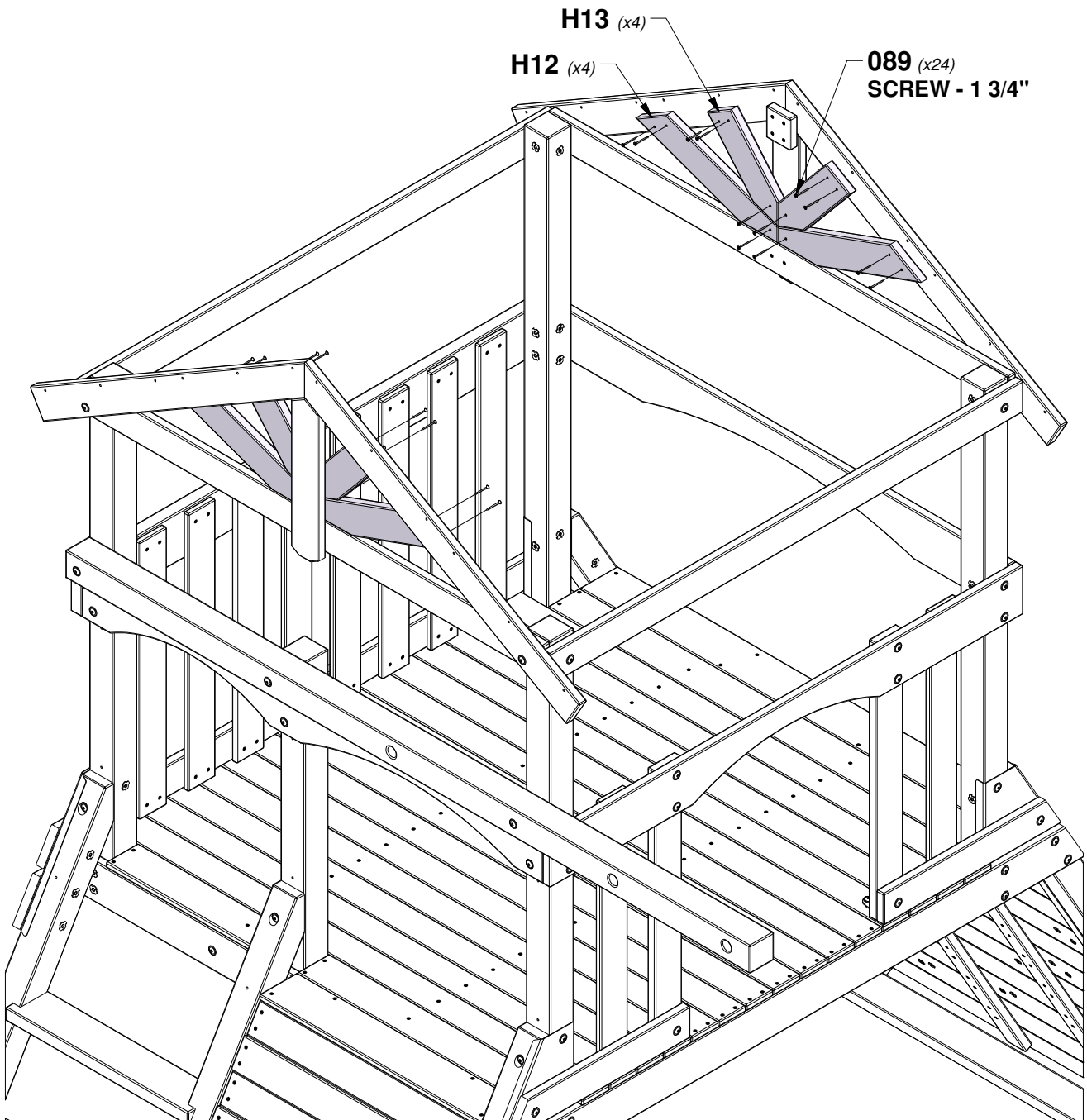
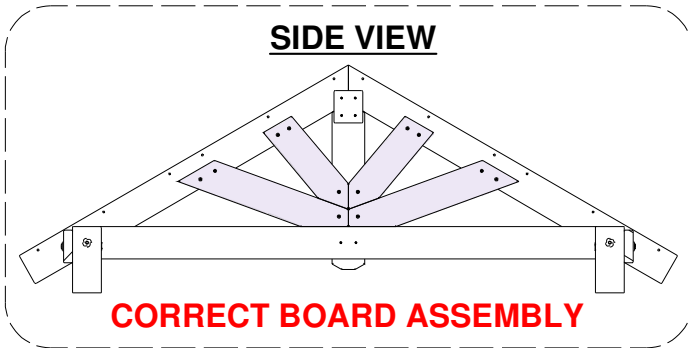

STEP 31 - FORT ASSEMBLY

QTY	PART NUMBER	DESCRIPTION
12	H100091	SCREW PFH 8x2-1/4"



RP1 | PEAK ROOF PANEL - W2A03276
 (x2) | 1 5/8"x20 5/8"x59" (42x511x1676)

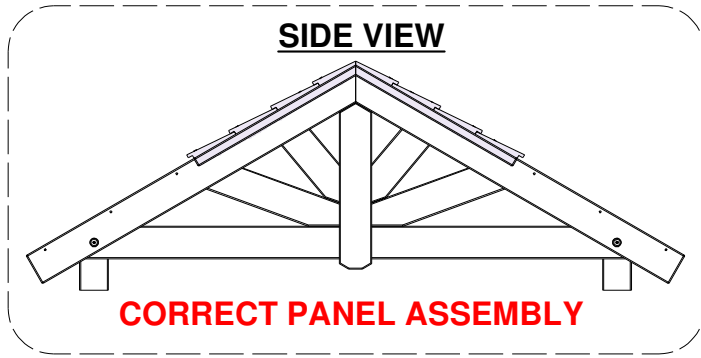

091 (x12)
 SCREW - 2 1/4"

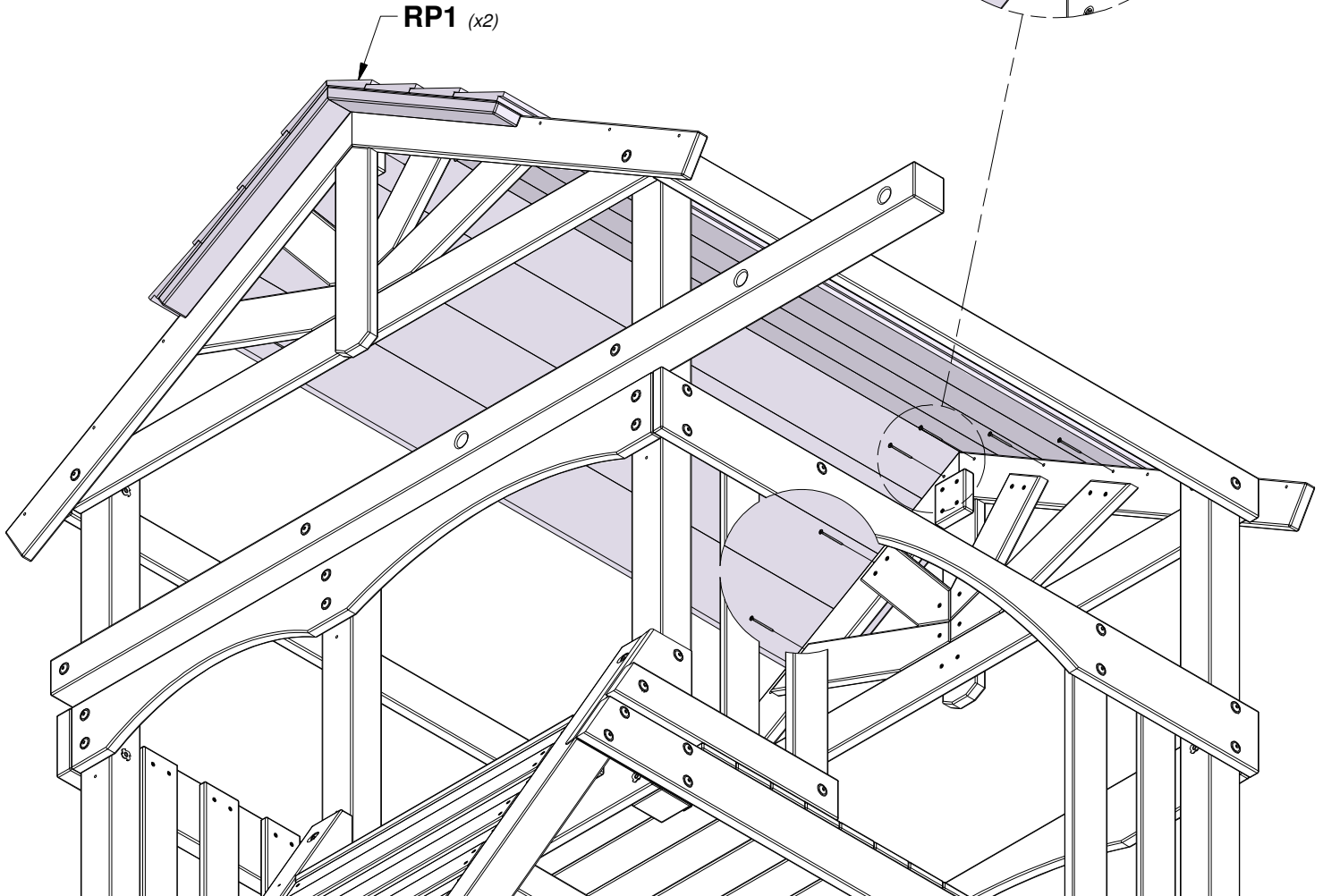
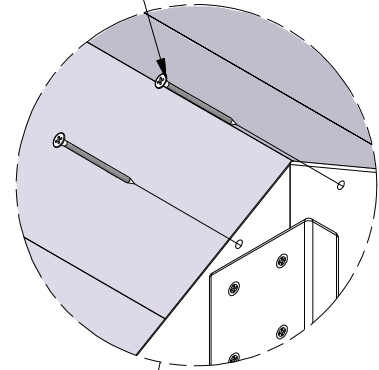

STEP 32 - FORT ASSEMBLY

QTY	PART NUMBER	DESCRIPTION
12	H100091	SCREW PFH 8x2-1/4"

•	•
•	•
•	•
•	•
•	•
•	•

RP2 | ROOF PANEL - W2A03277
 (x2) | 1 5/8"x20 5/8"x66" (42x524x1676)

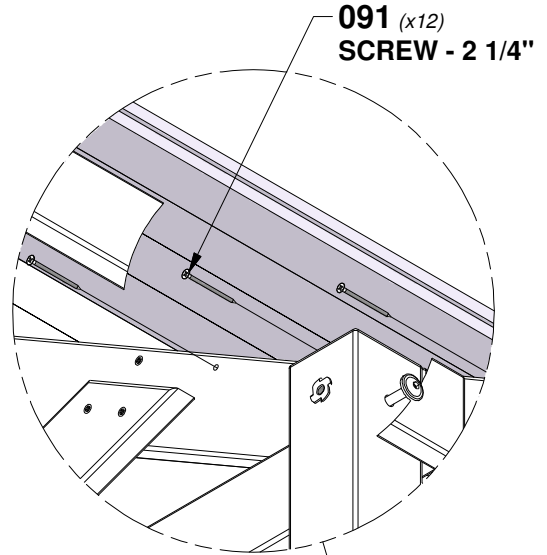
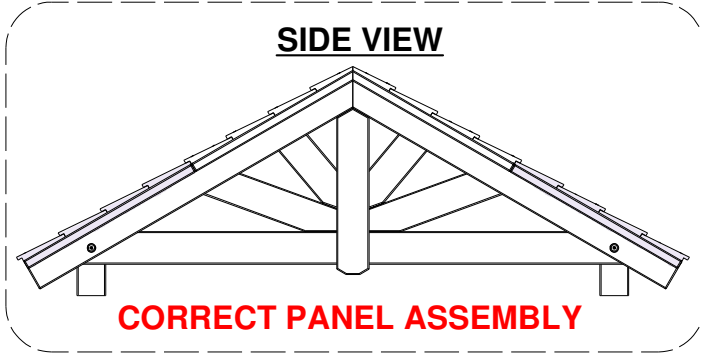

RP2 (x2)

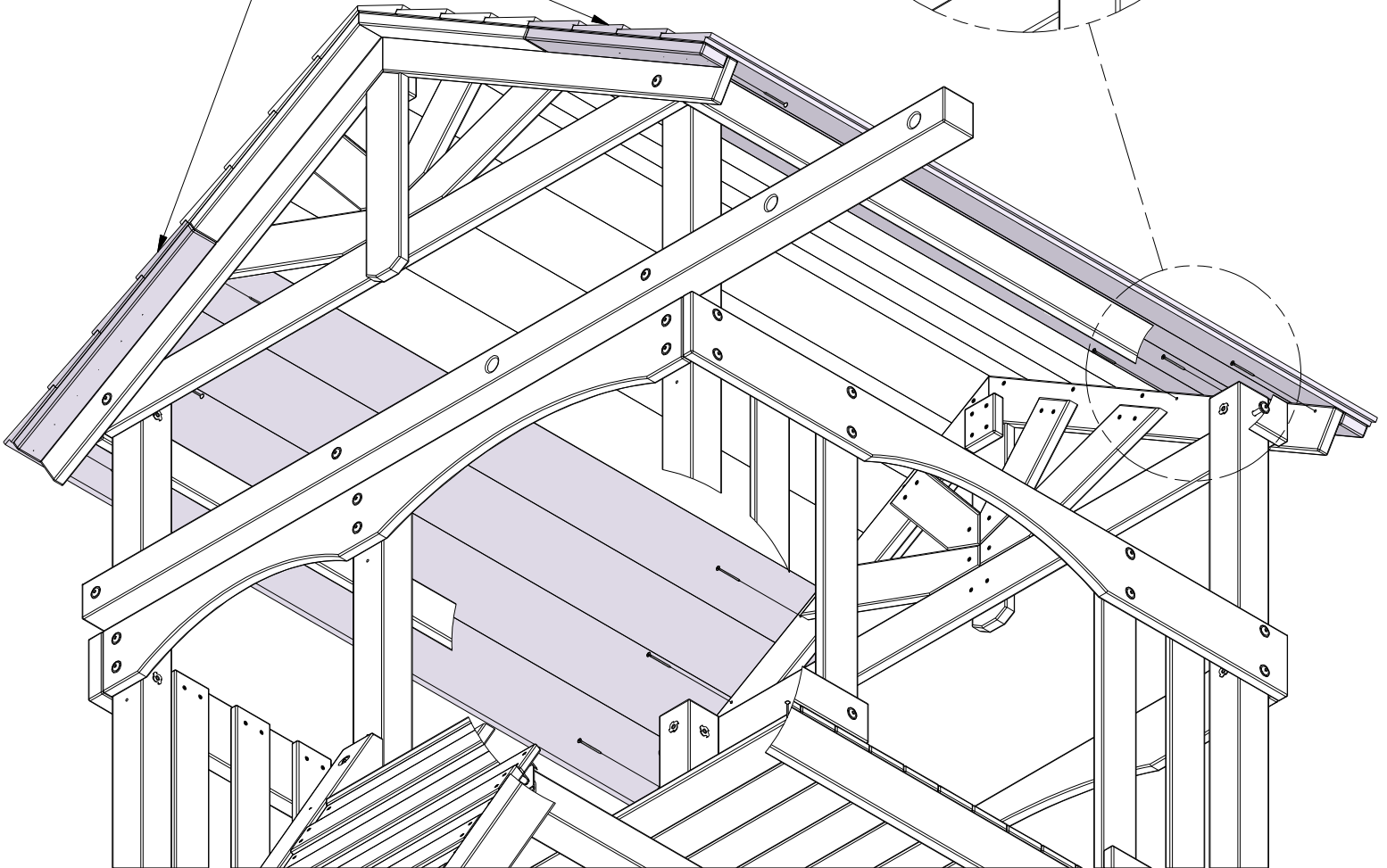

STEP 33 - FORT ASSEMBLY

QTY	PART NUMBER	DESCRIPTION
24	H100380	SCREW PFH 8x1 1/8 BLK



N01 | ROOF CLEAT - W4L15990
 (x4) | 5/8"x2 3/8"x31 1/2" (16x60x800)

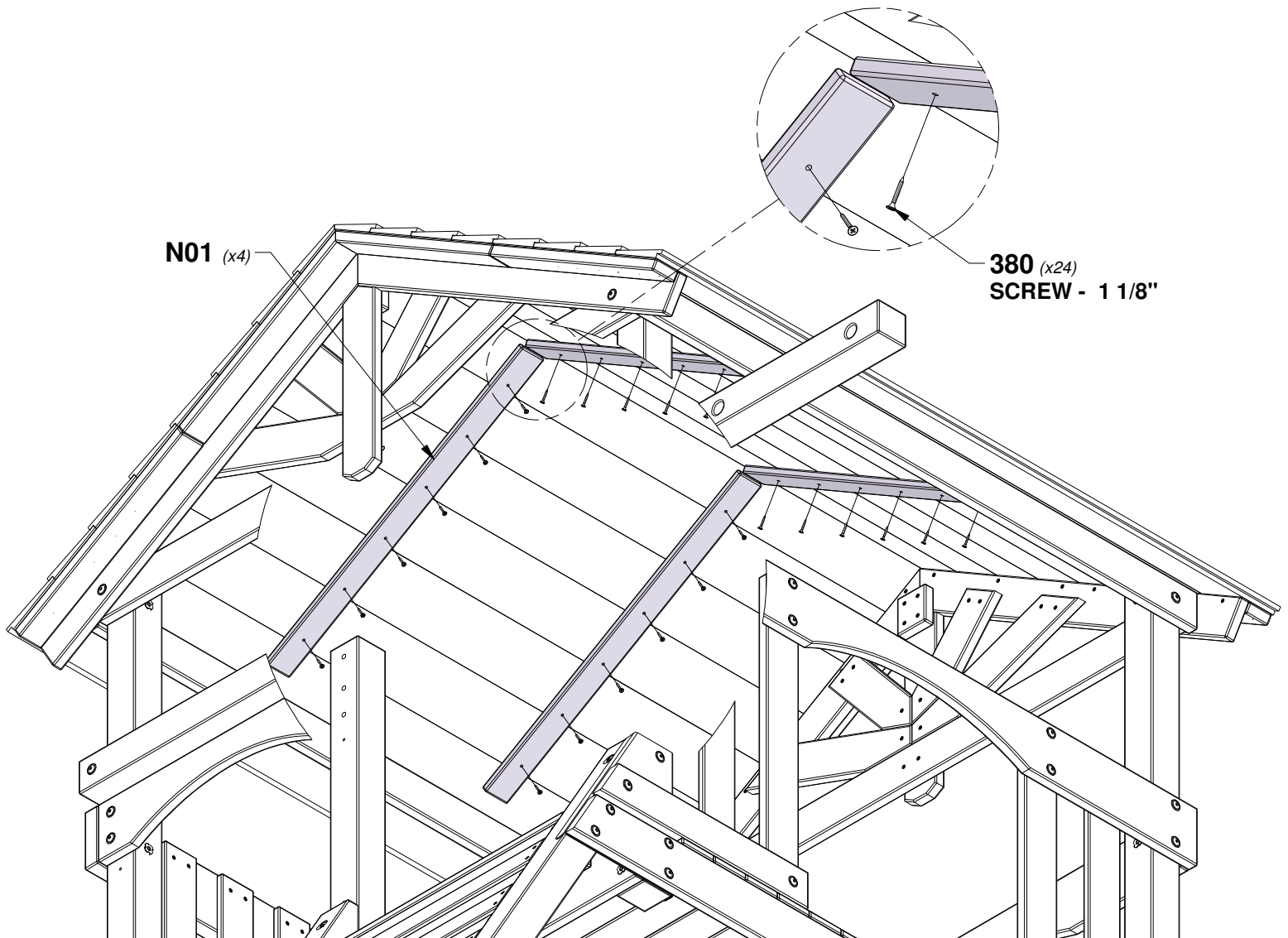
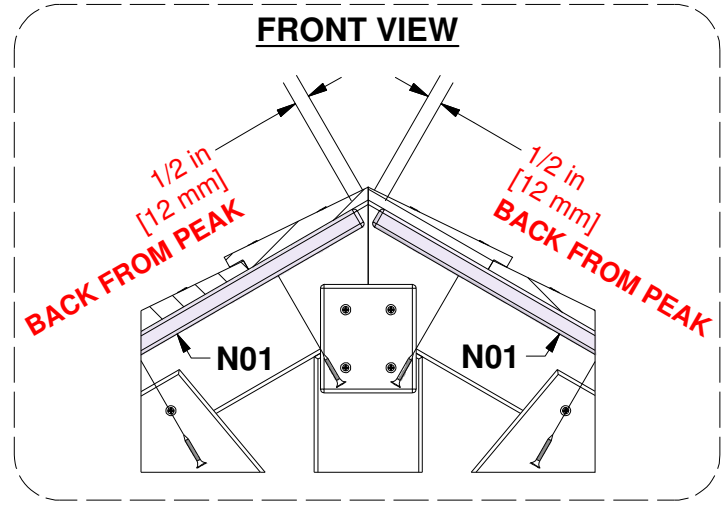
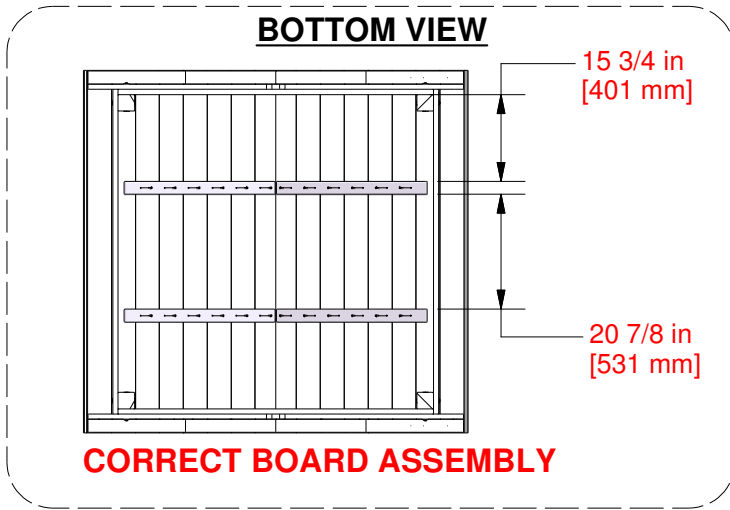

STEP 34 - FORT ASSEMBLY

QTY	PART NUMBER	DESCRIPTION
4	H100027	LAG SCREW WH 5/16x2

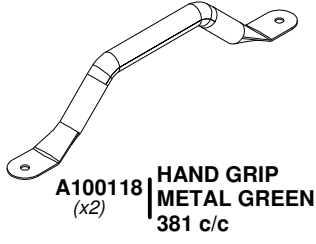

A100118 | **HAND GRIP**
(x2) | **METAL GREEN**
381 c/c

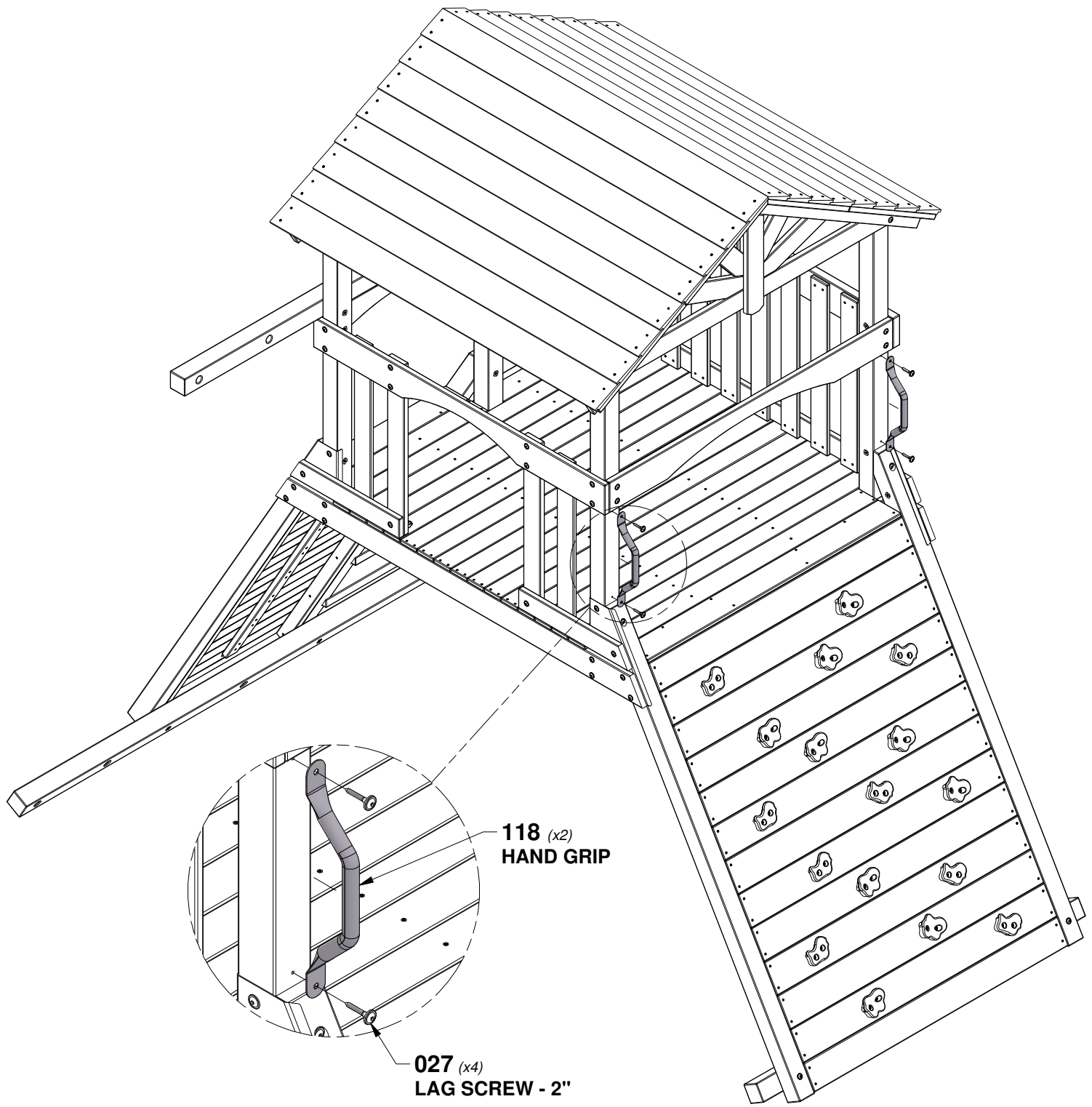

118 *(x2)*
HAND GRIP

027 *(x4)*
LAG SCREW - 2"

STEP 35 - FORT ASSEMBLY

QTY	PART NUMBER	DESCRIPTION
6	H100027	LAG SCREW WH 5/16x2



A100118 | **HAND GRIP**
(x3) | **METAL GREEN**
381 c/c

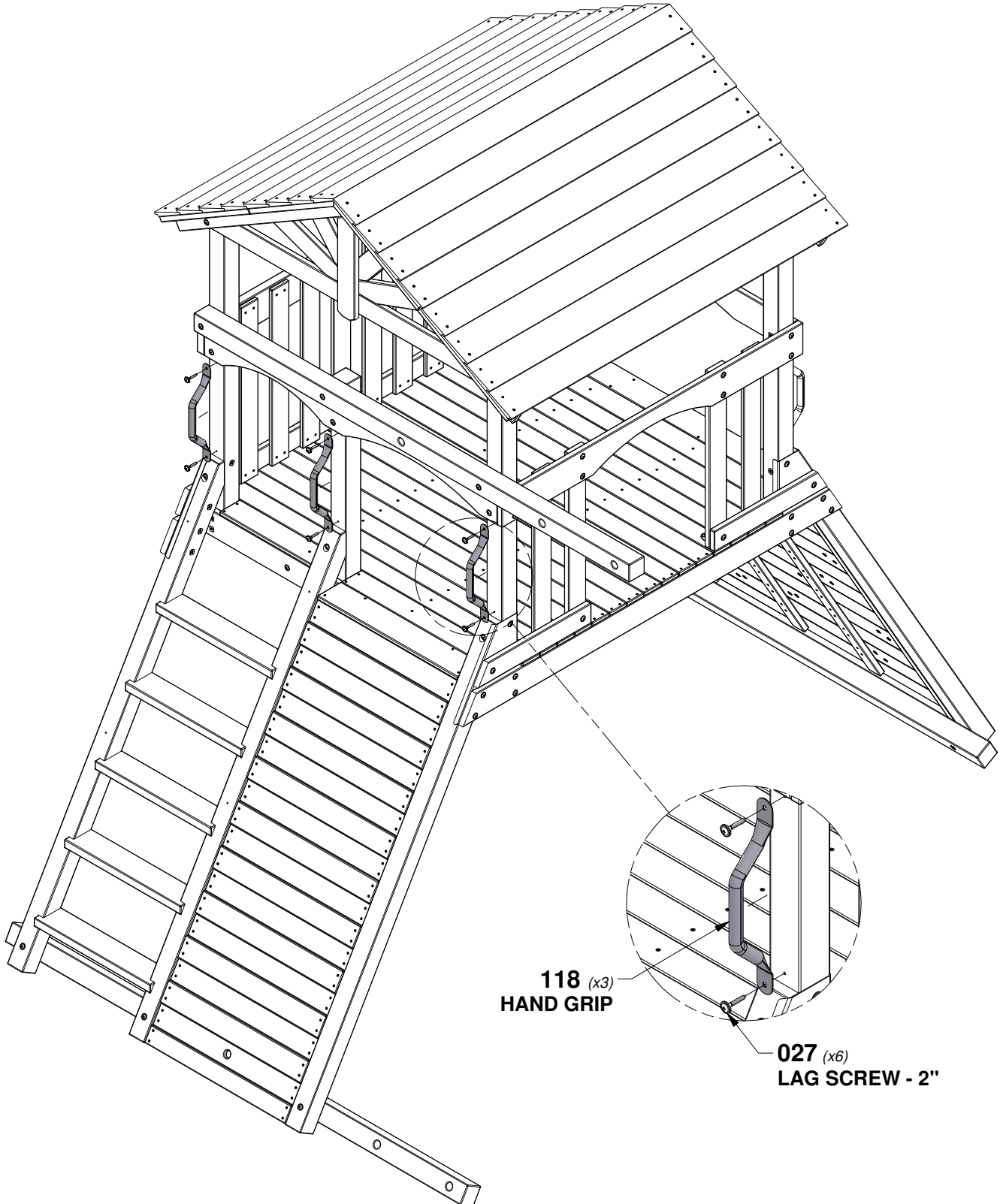

118 *(x3)*
HAND GRIP

027 *(x6)*
LAG SCREW - 2"

STEP 36 - FORT ASSEMBLY

QTY	PART NUMBER	DESCRIPTION
4	H100027	LAG SCREW WH 5/16x2

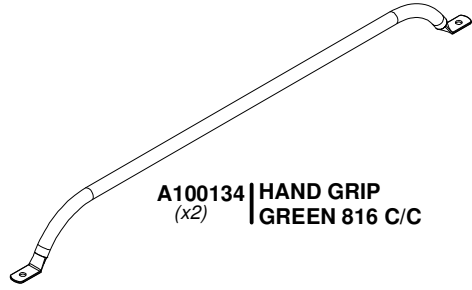

A100134 | **HAND GRIP**
(x2) | **GREEN 816 C/C**

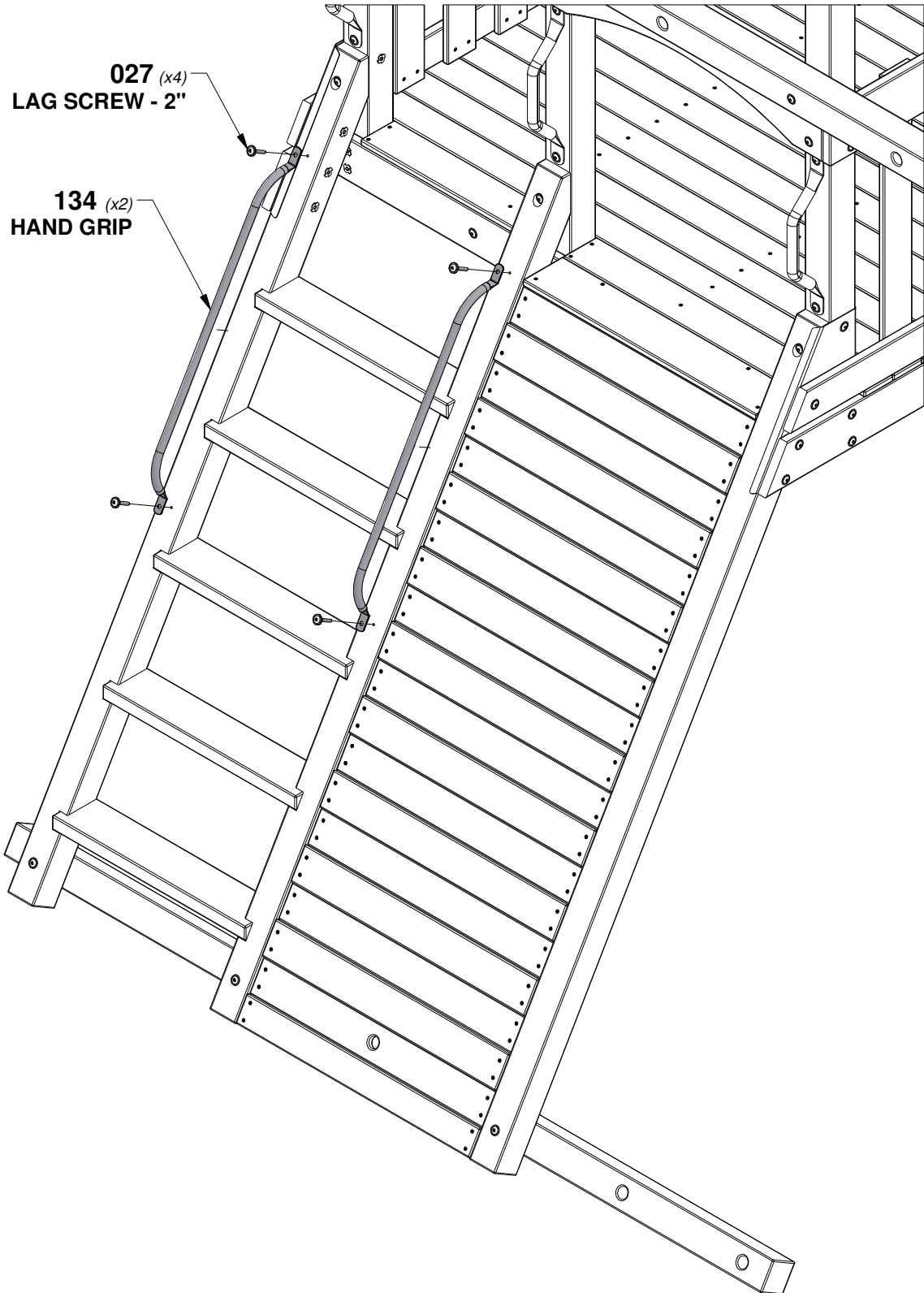

027 (x4)
LAG SCREW - 2"

134 (x2)
HAND GRIP

STEP 37 - FORT ASSEMBLY

QTY	PART NUMBER	DESCRIPTION
2	H100050	BOLT HEX 5/16x3 1/4
2	H100095	WASHER SPLIT 5/16
2	H100105	WASHER FLAT 8x27

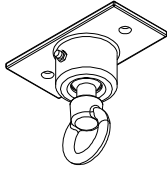

H100338
(x1) | TIRE SWIVEL

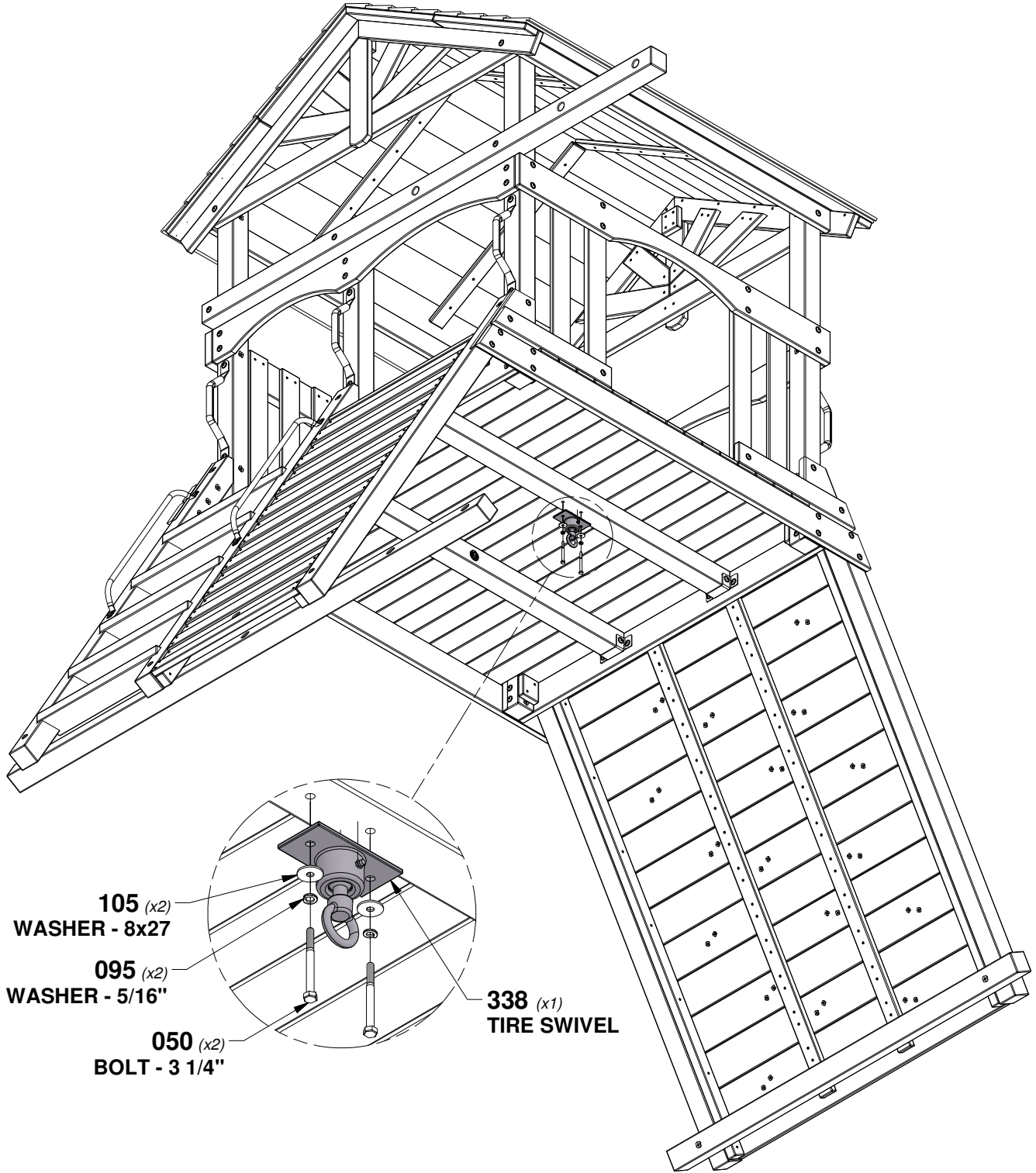

STEP 38 - FORT ASSEMBLY

QTY	PART NUMBER	DESCRIPTION
4	H100477	WASHER SPLIT 5/16 BLK
4	H100478	WASHER FLAT 8x27 BLK
4	H100498	BOLT HEX 5/16x1-1/2 - BLK

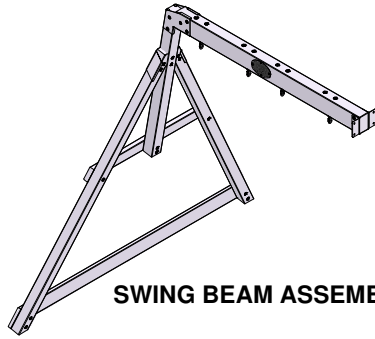

SWING BEAM ASSEMBLY

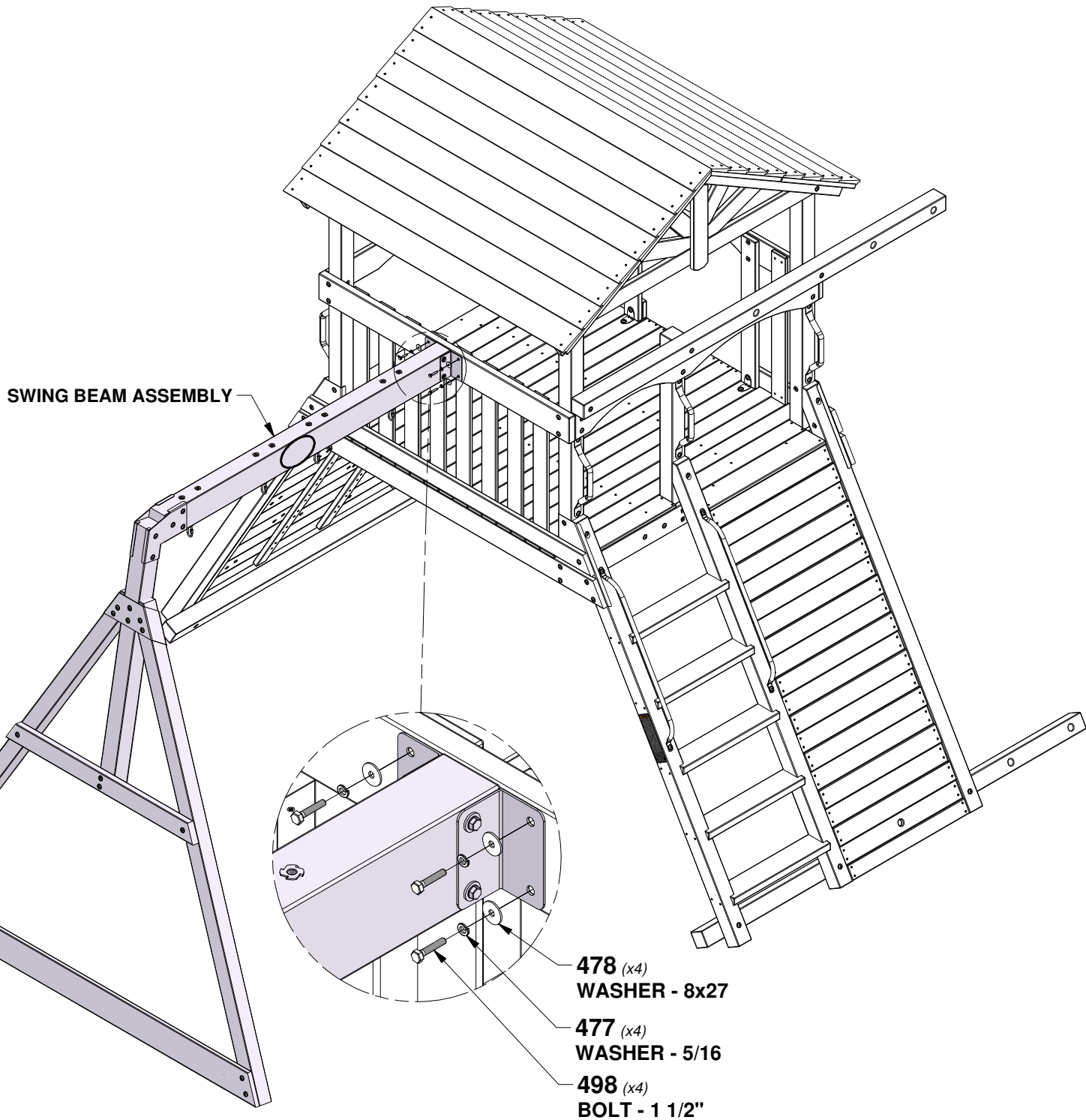

STEP 39 - FORT ASSEMBLY



A100027 | SWING SEAT
(x2) | GREEN 26"



A100069 | QUICK LINK
(x4)

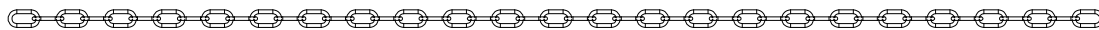

A100047 | CHAIN GREEN
(x4) | 57"

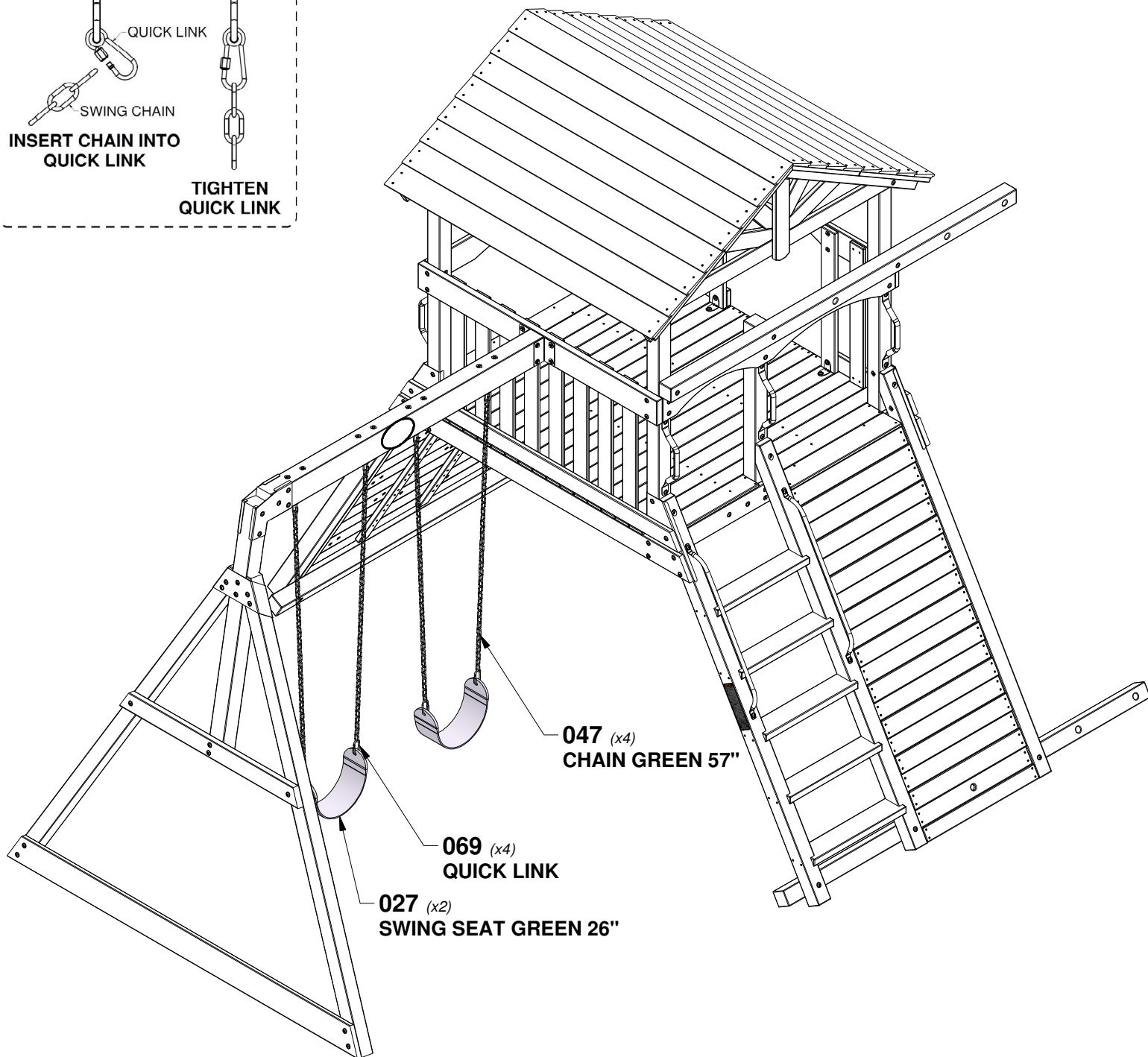
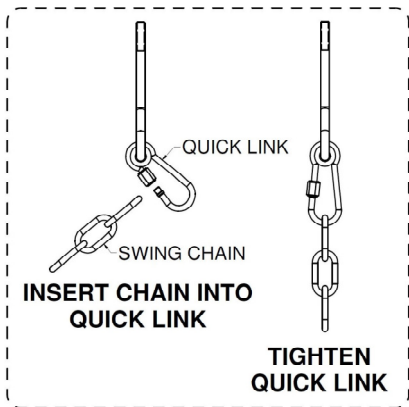

STEP 1 - WEB SWING ASSEMBLY

QTY	PART NUMBER	DESCRIPTION
4	H101121	BOLT PTH 1/4x1 BLK with LOCTITE
4	H100831	NUT BARREL PTH 1/4x3/4 BLK

WEB SWING SETUP INSTRUCTIONS

FOLLOW INSTRUCTIONS BELOW BEFORE USING THE WEB SWING.

IMPORTANT:
SLIDE ROPE LOOPS OVER TUBE ENDS FIRST!
(SEE VIEW BELOW)

SLIDE NARROW END OF TUBES INTO LARGER OPENING AFTER SLIDING ROPE LOOPS ONTO TUBES.

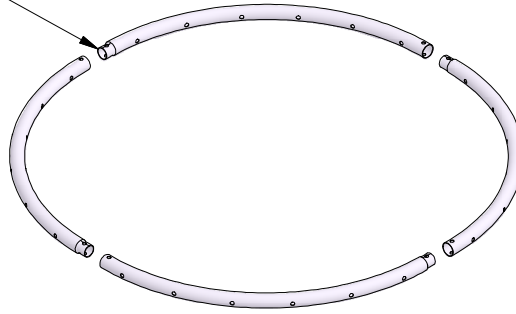

NOTE: ROPE WEBBING NOT SHOWN IN ILLUSTRATION FOR CLARITY.

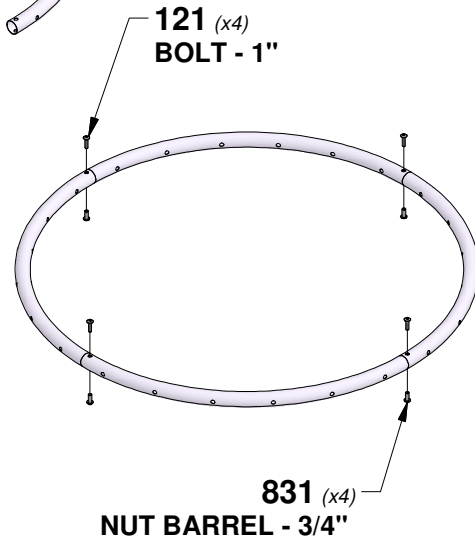

NOTE: IT IS IMPORTANT THAT THE WEB SWING HANG LEVEL.

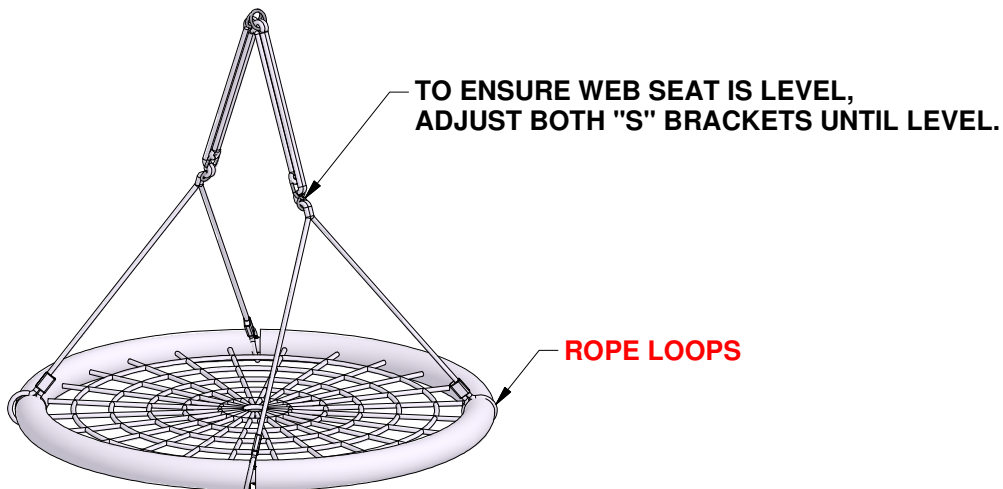

SWING MUST BE SET AT A MINIMUM OF 8 INCHES OFF THE GROUND WHEN INSTALLED.

STEP 40 - FORT ASSEMBLY



A4M01044 | CARABINER SD
(x1)

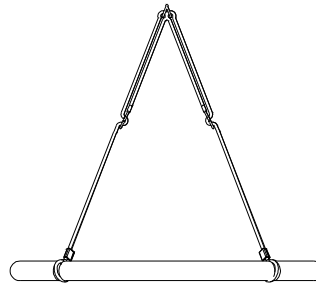

A4M01495 | 40" WEB SWING
(x1)

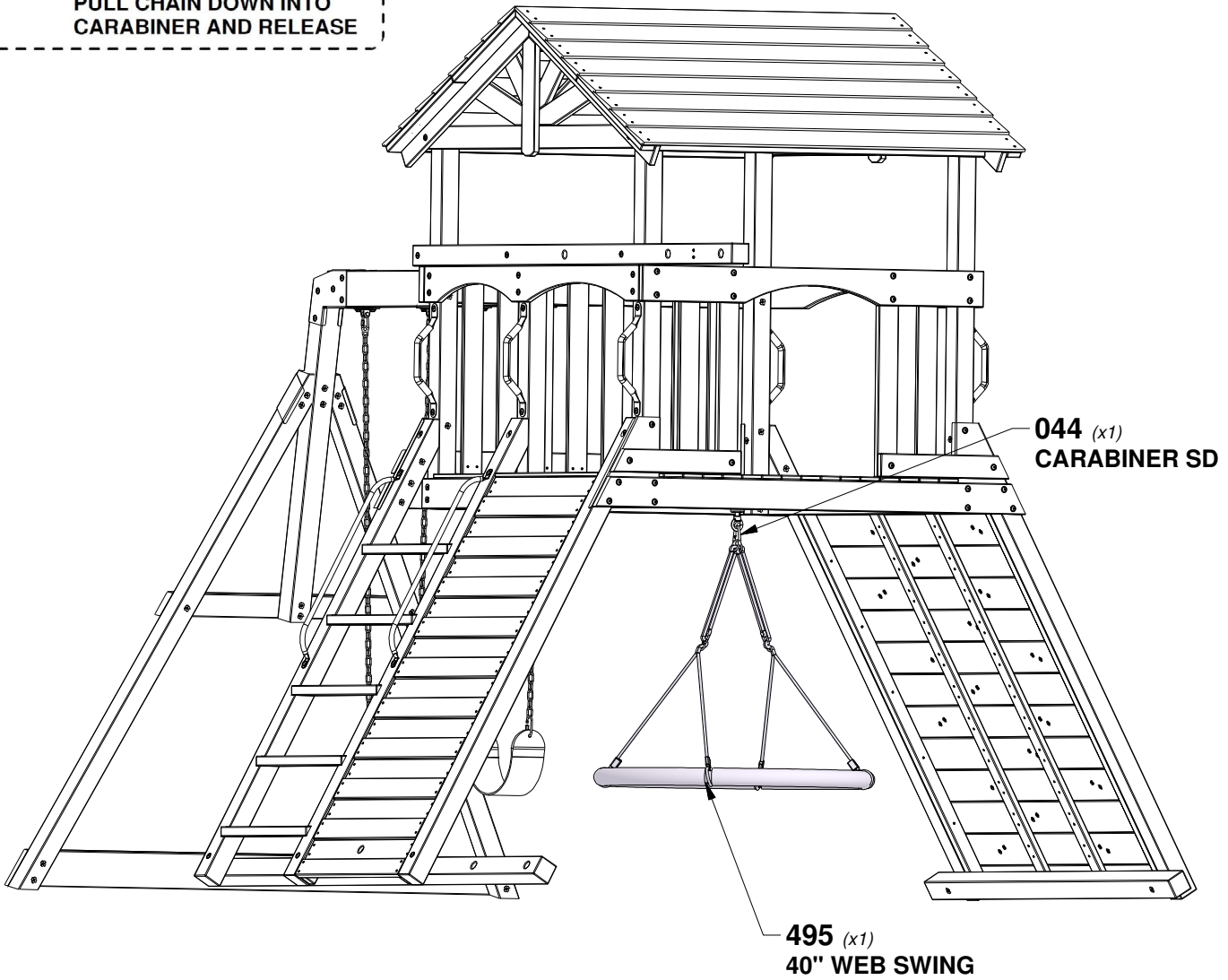
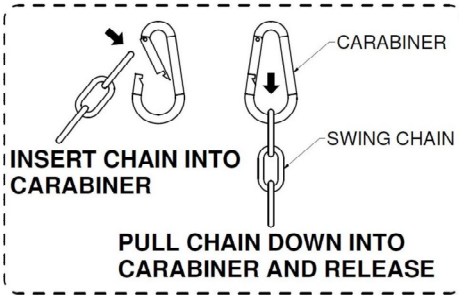

STEP 1 - ROPE CLAMP ASSEMBLY

ROPE CLAMP ATTACHED IN NEXT STEP.

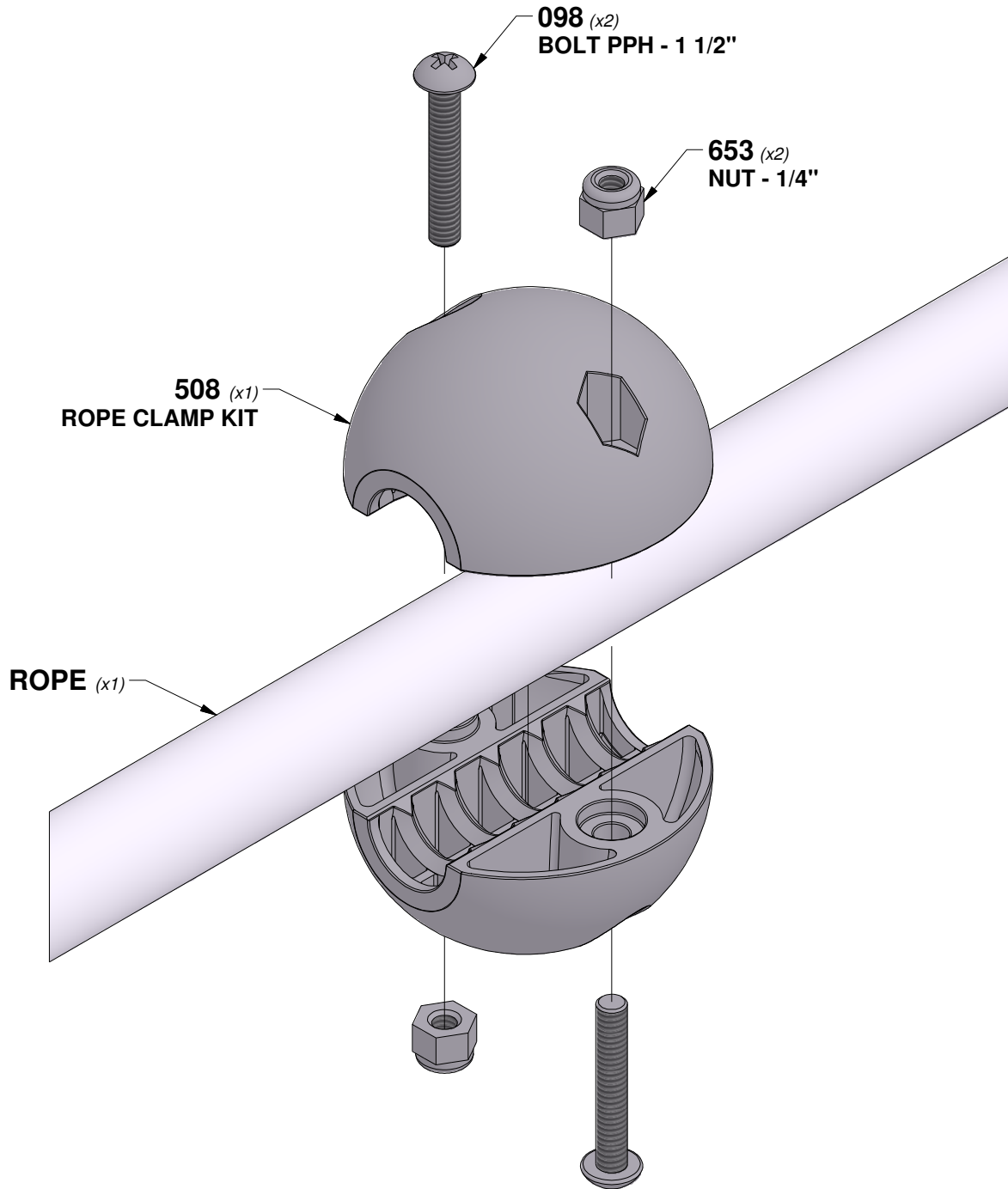

STEP 41 - FORT ASSEMBLY

A6P00508 (x7) ROPE CLAMP KIT

A6P00507 (x1) ROPE

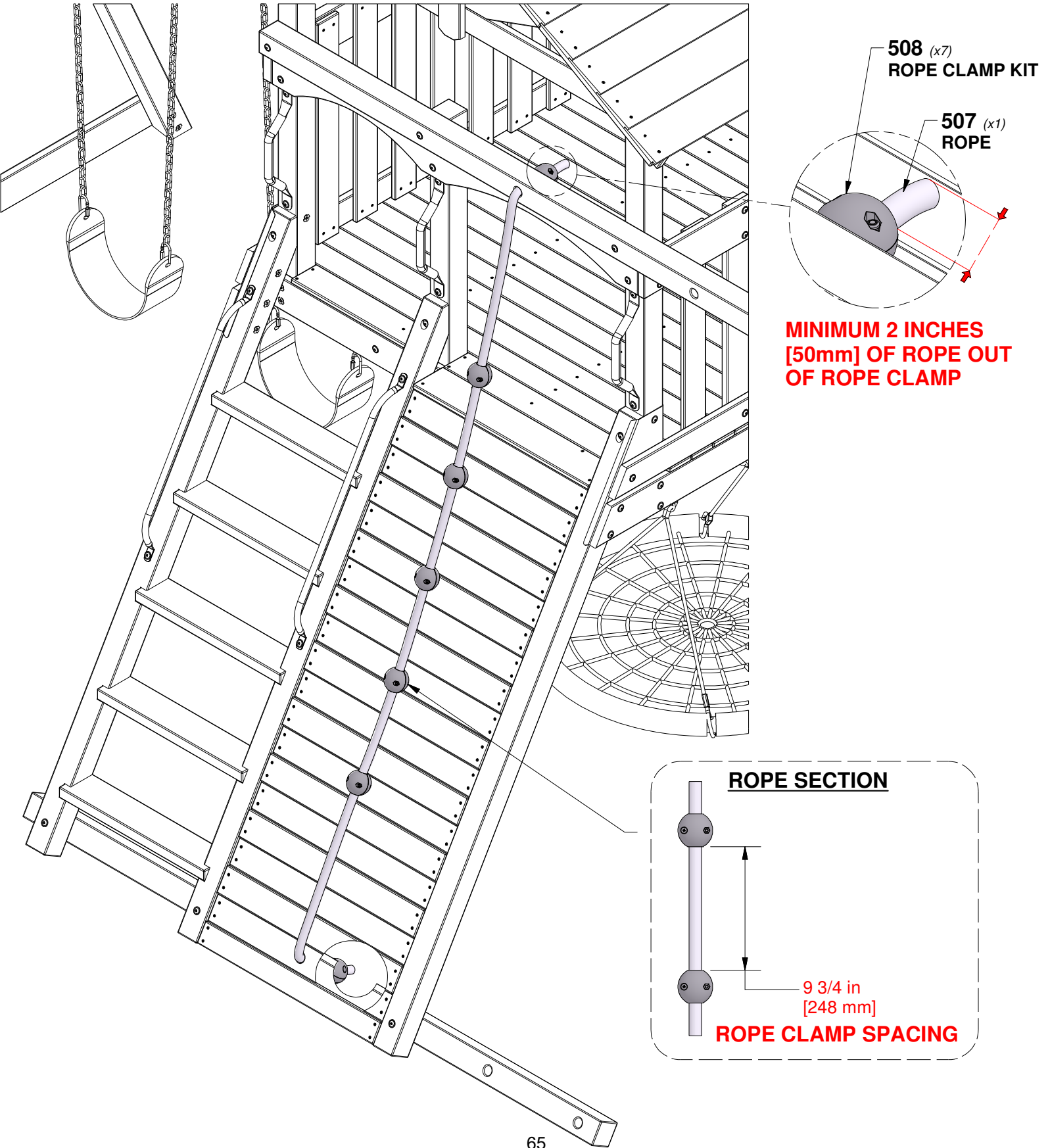

STEP 42 - FORT ASSEMBLY



H06 | ROPE LADDER RUNG - W4L15982
(x6) | 1"x3 3/8"x19 5/8" (24x86x500)



A6P00508 | ROPE CLAMP KIT
(x16)

A6P00507 | ROPE
(x2)

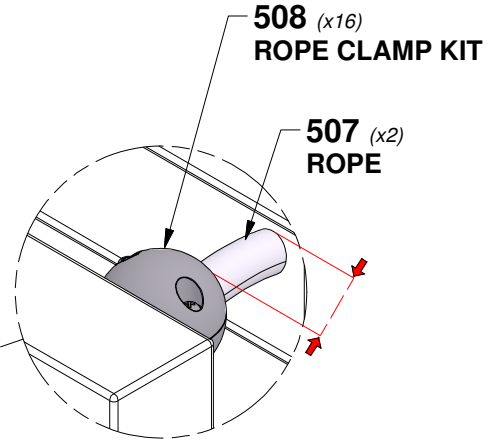
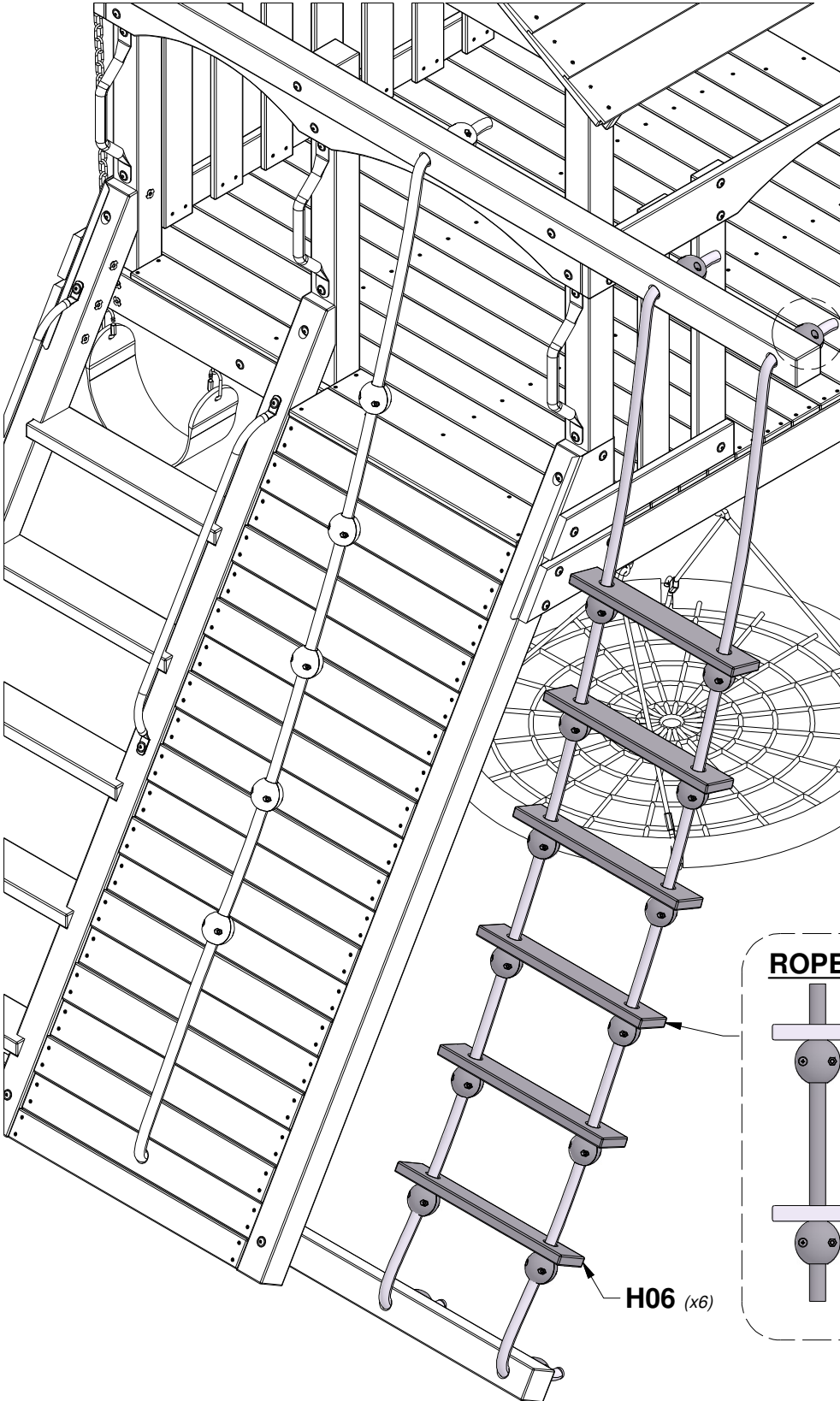

**MINIMUM 2 INCHES
[50mm] OF ROPE OUT
OF ROPE CLAMP**

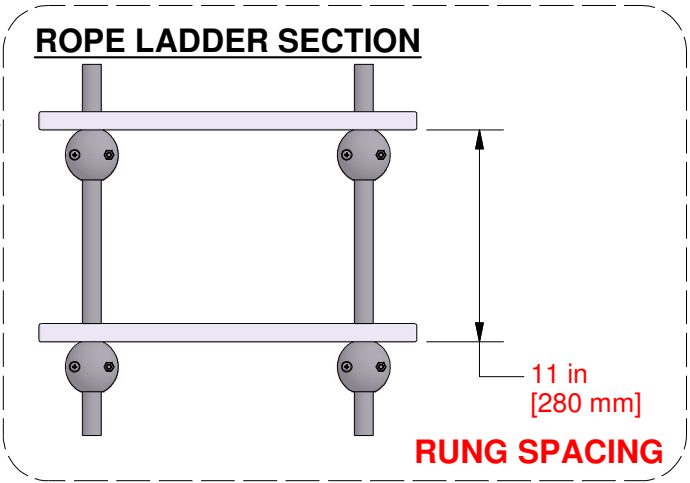

STEP 43 - FORT ASSEMBLY

QTY	PART NUMBER	DESCRIPTION
2	H100392	SCREW PWH 8x3/4 BLK

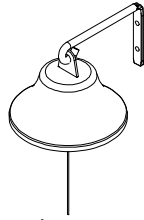

A4M00554
(x1) | **BELL ASSEMBLY**

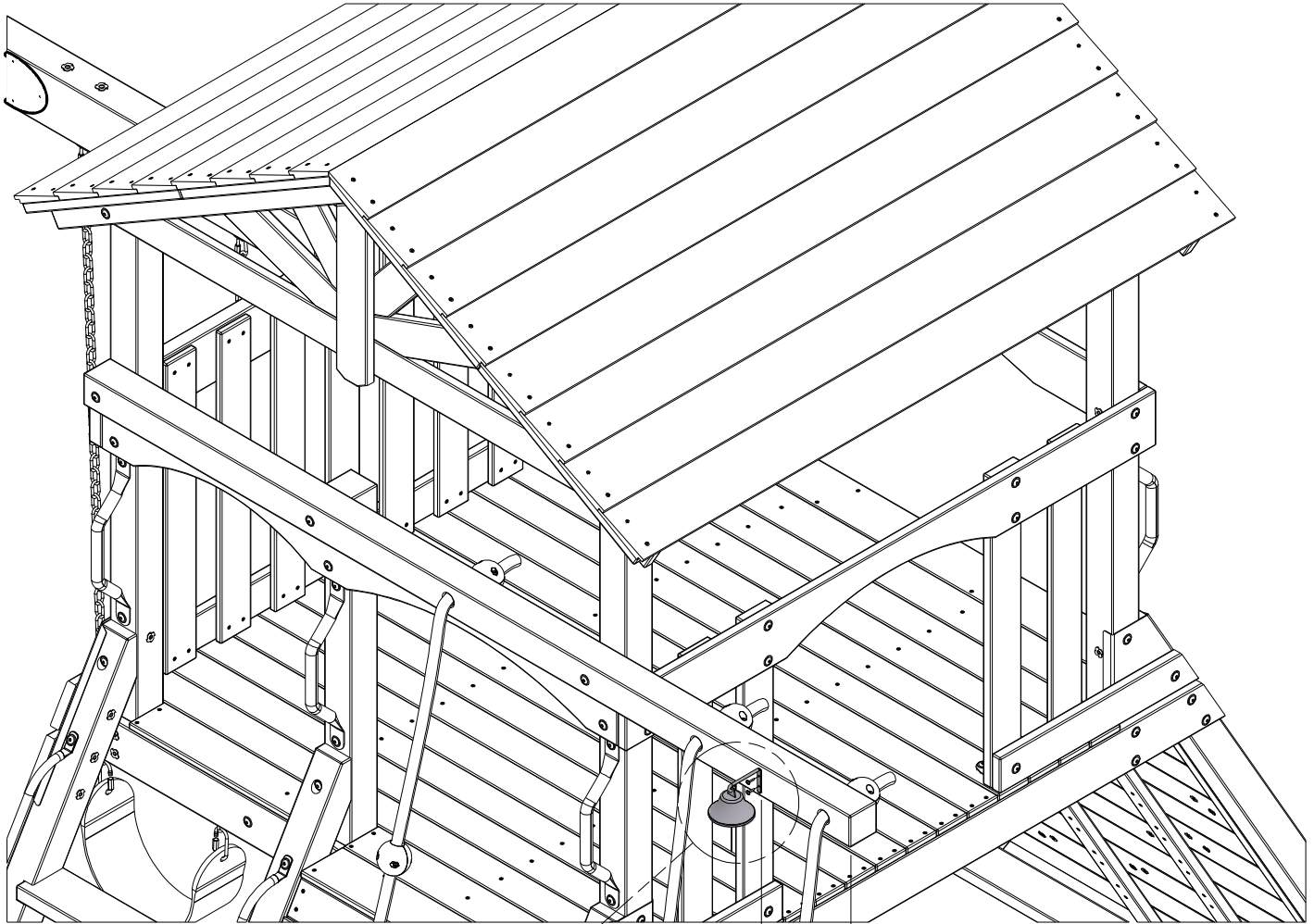

9 7/8 in
[250 mm]

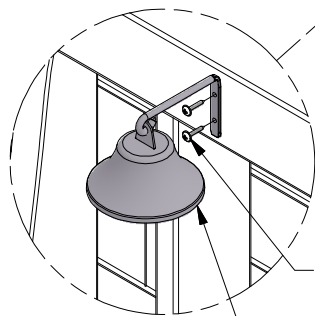

392 *(x2)*
SCREW - 3/4"

554 *(x1)*
BELL ASSEMBLY

STEP 44 - FORT ASSEMBLY

QTY	PART NUMBER	DESCRIPTION
2	H100086	SCREW PFH 8x1-1/2"

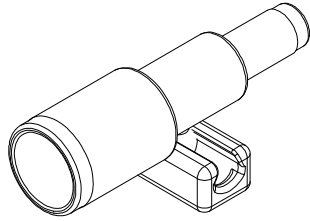

A6P00096 | TELESCOPE
(x1)

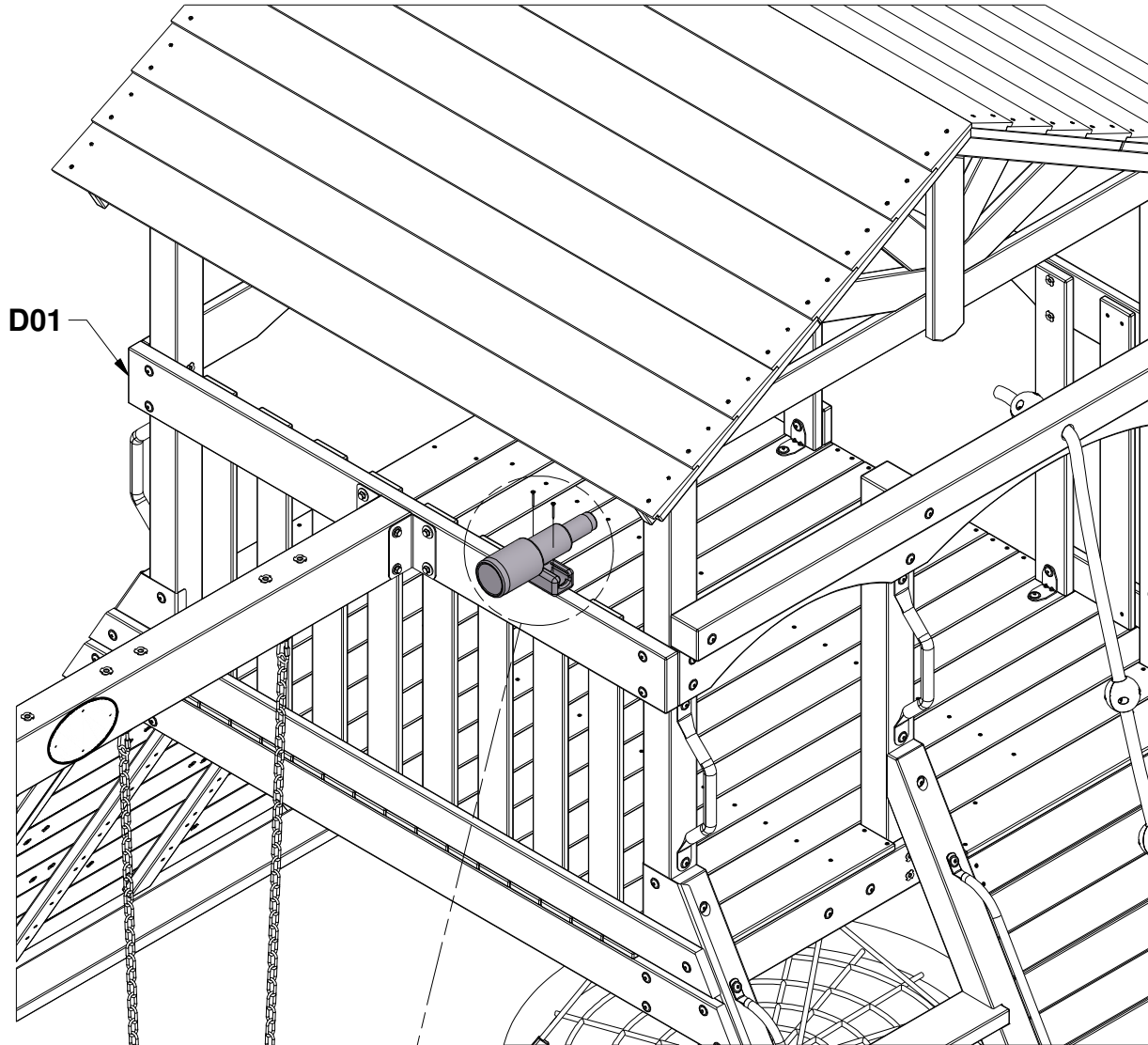

D01

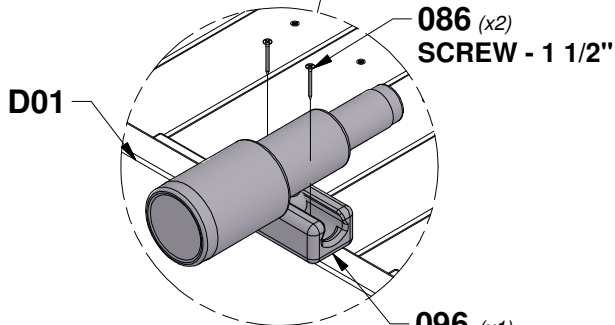

086 (x2)
SCREW - 1 1/2"

096 (x1)
TELESCOPE

CENTER IN D01 BOARD

STEP 45 - FORT ASSEMBLY

QTY	PART NUMBER	DESCRIPTION
3	H100009	BOLT WH 5/16x1-1/4"
3	H100074	T-NUT 5/16"
4	H100088	SCREW PFH 8x1-1/8"



(x1) SLIDE VF 10 FT



O70 | SLIDE MOUNTING BOARD - W4L09040
(x1) | 5/8"x1 3/8"x20 3/8" (16x34x517)

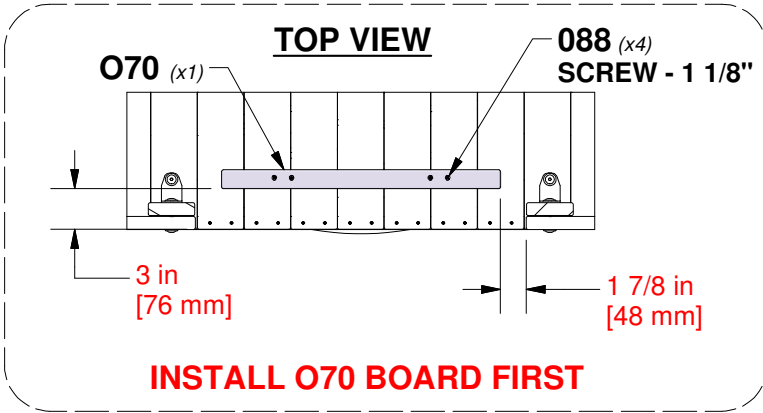

10 FT VACUUM FORMED SLIDES		
PART NUMBER	COLOR	MODEL NUMBER
A100287	GREEN	2200104
A6P00540	YELLOW	2300316
A6P00539	GREY	2300033

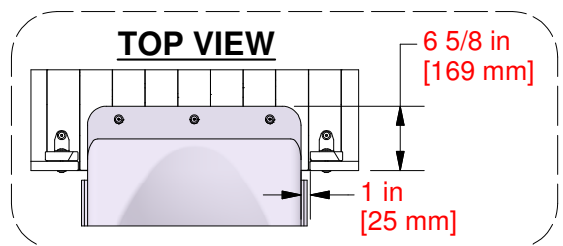
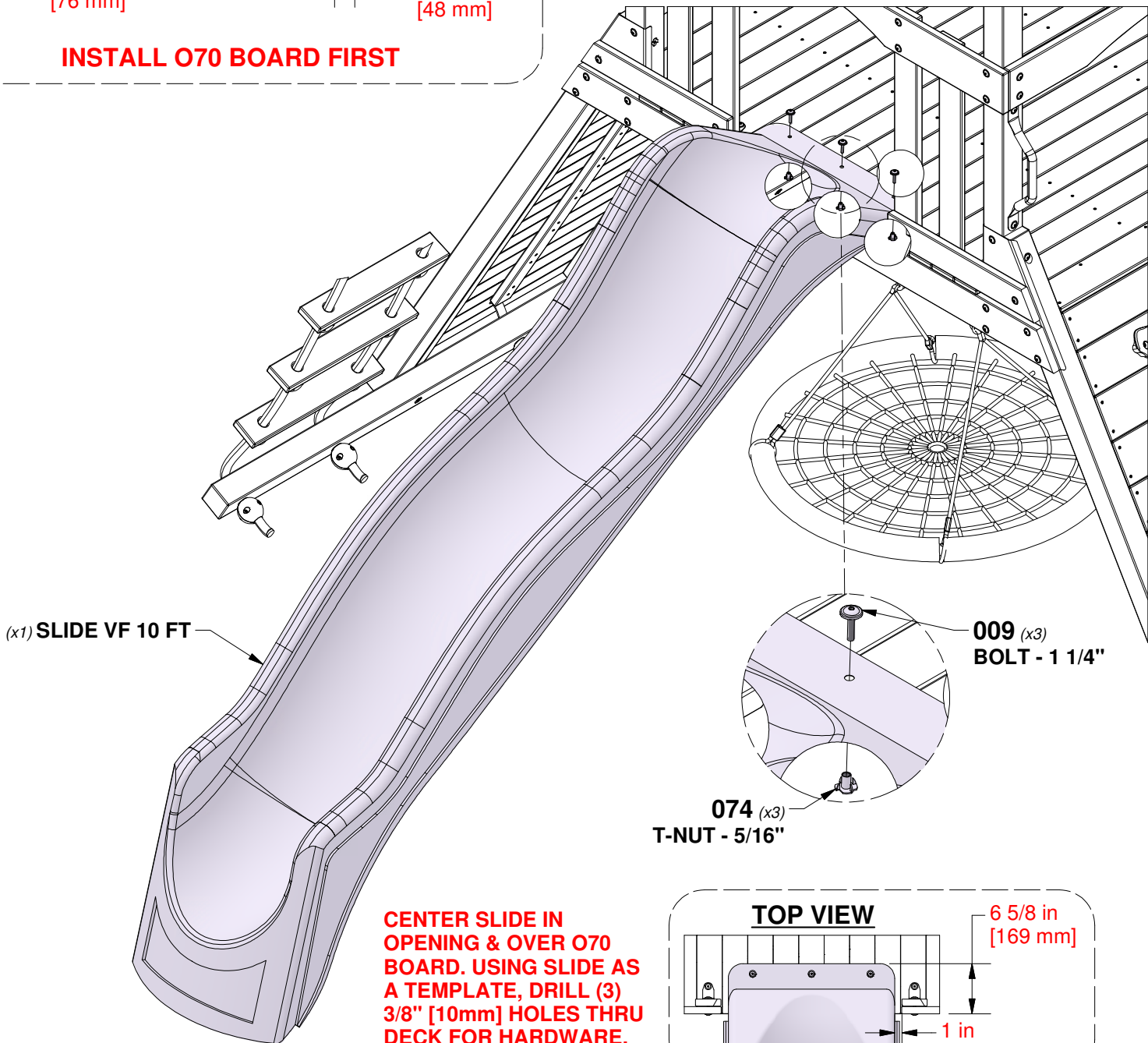

STEP 46 - FORT ASSEMBLY

QTY	PART NUMBER	DESCRIPTION
2	H100004	NUT BARREL WH 5/16x5/8
2	H100008	BOLT WH 5/16x1
4	H100028	LAG SCREW WH 5/16x2 1/2
2	H100031	WASHER LOCK EXT 12x19

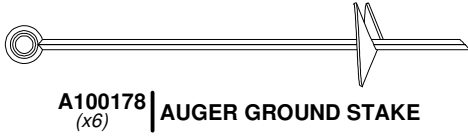

DETAIL - A

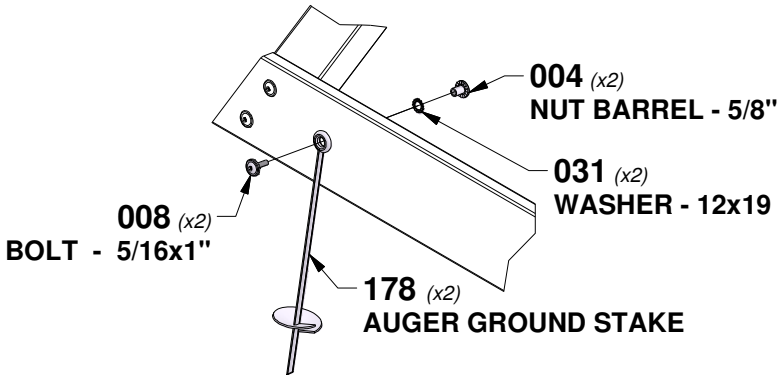

TWIST GROUND STAKE INTO GROUND AT LOCATIONS SHOWN. USING GROUND STAKE AS A GUIDE, DRILL A 7/16" [10mm] HOLE FOR HARDWARE.

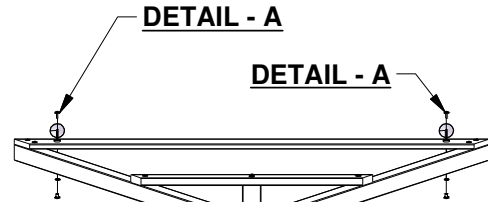

DETAIL - B

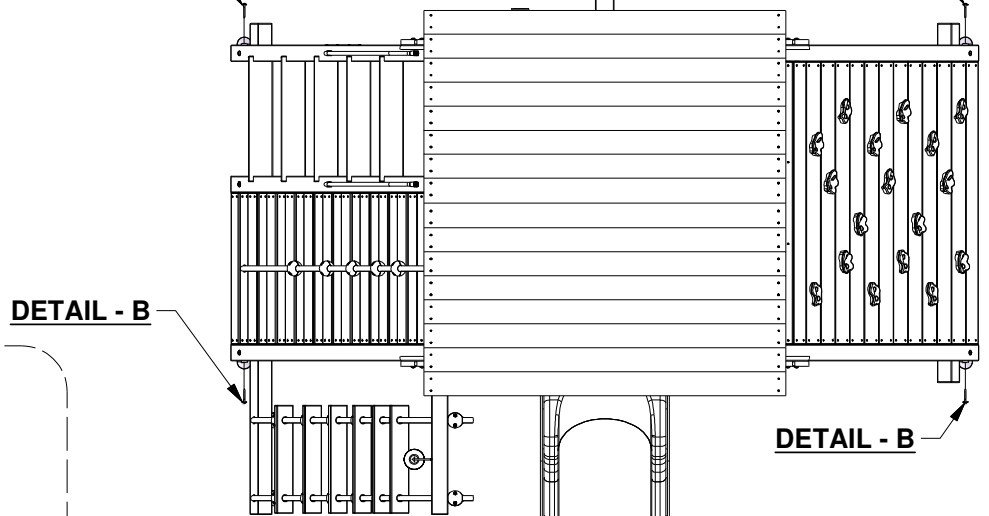

DETAIL - B

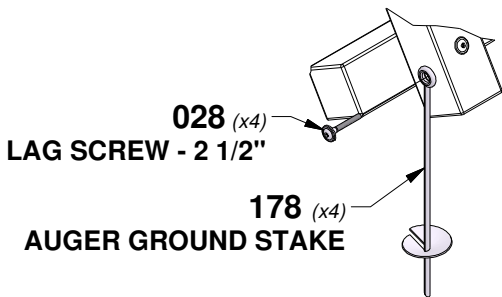

TWIST GROUND STAKE INTO GROUND AT LOCATIONS SHOWN. USING GROUND STAKE AS A GUIDE, DRILL A 3/16" [5mm] PILOT HOLE FOR LAG BOLT.