



Manufactured by:  
Backyard Discovery  
3305 Airport Drive, Pittsburg, KS 66762  
800-856-4445

*Basepoint Business Centre: Rivermead Drive, Westlea, Swindon SN5 7EX Phone: 0800-118-2476 J.P. Coenstraat 7, The Bridge, The Hague, 2595 WP, Netherlands Phone: 08005678990*

# 20x12 KINGSPORT GAZEBO GUTTER KIT MODEL #: 9260160



**Please visit [www.backyarddiscovery.com](http://www.backyarddiscovery.com)**  
For the most up to date assembly manual, to register your product, or to order  
replacement parts Para obtener instrucciones en español, visite  
[www.backyarddiscovery.com](http://www.backyarddiscovery.com)

# OWNER'S MANUAL - PARTS IDENTIFICATION

## Hardware Components



**H101414 SCREW SELF PIERCING #8x1/2 BLK**  
(x5) #8 x 1/2

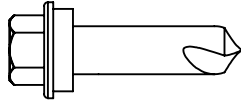

**H101480 SCREW SELF TAPPING #9x1 BLK**  
(x8) 1/4 x 1

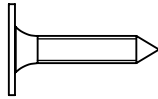

**H101205 SCREW PWH BLK**  
(x4) 8x3/4

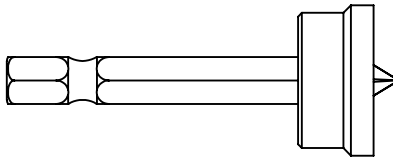

**H100764 SCREW SETTER**  
(x1)

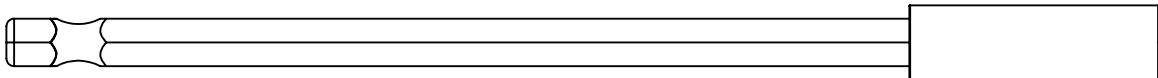

**H101278 6" MAGNETIC DRIVER EXTENSION**  
(x1)



**A6P01531 10 OZ SILICONE TUBE**  
(x1)

# OWNER'S MANUAL - PARTS IDENTIFICATION

## Hardware Components

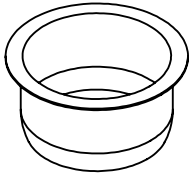

**A4M04761 DOWNSPOUT OUTLET**  
(x1) 1 7/16"x2 7/8" [37x73]

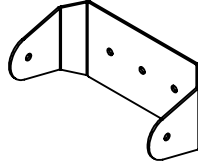

**A4M04782 DOWNSPOUT CLIP**  
(x2) 1 7/16"x1 7/16"x3 1/8" [36x36x79]

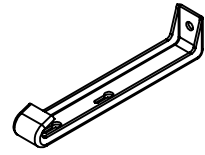

**A4M04759 GUTTER HANGER**  
(x8) 3/4"x1"x4 15/16" [19x25x125]

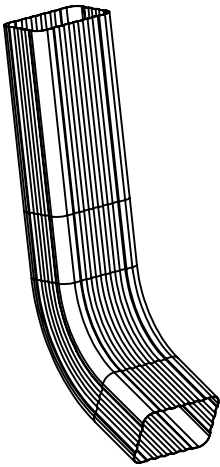

**A4M06238 LONG DOWNSPOUT ELBOW**  
(x1) 3"x10 5/8"x10 11/16" [76x270x271]

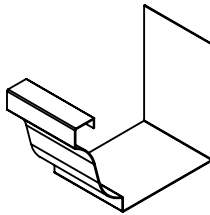

**A4M04765 GUTTER SPLICE**  
(x1) 2 1/2"x3 11/16"x5 1/16" [63x94x129]

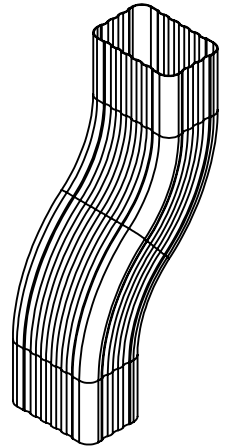

**A4M06822 DOWNSPOUT OFFSET - 3"**  
(x1) 3"x4 15/16"x10 1/4" [76x125x260]



**A4M04783 DOWNSPOUT - 5FT**  
(x1) 2"x3"x60" [51x76x1524]

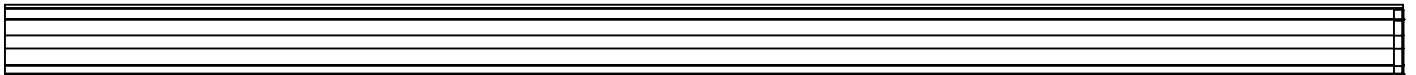

**A4M06906 RIGHT GUTTER**  
(x1) 3 11/16"x5 1/8"x72 13/16" [94x130x1849]

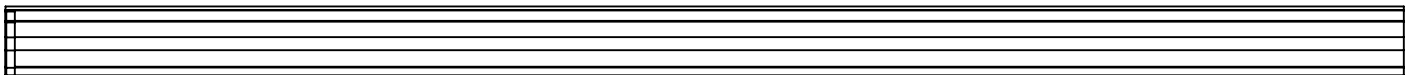

**A4M06907 LEFT GUTTER**  
(x1) 3 11/16"x5 1/8"x72 13/16" [94x130x1849]

# GUTTER SPLICE PAGE

- NOTE:**
- APPLY SILICONE TO INSIDE CHANNEL ON BOTH SIDES.
  - ENSURE SILICONE IS EVENLY APPLIED ALONG THE CHANNEL.
  - AFTER GUTTER SPLICE HAS BEEN SLID ONTO GUTTERS AND SILICONE HAS HAD TIME TO CURE, USING HAND PRESSURE ONLY, FOLD THE TOP TAB OVER EDGE OF GUTTER

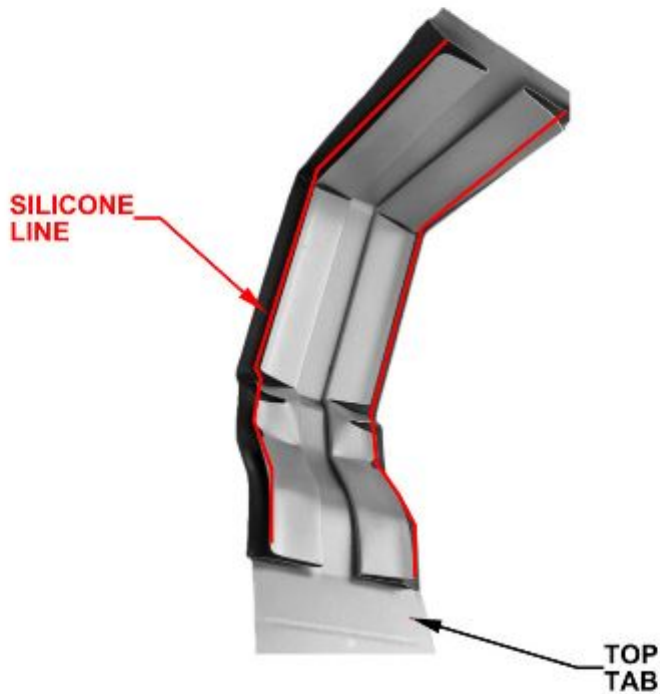
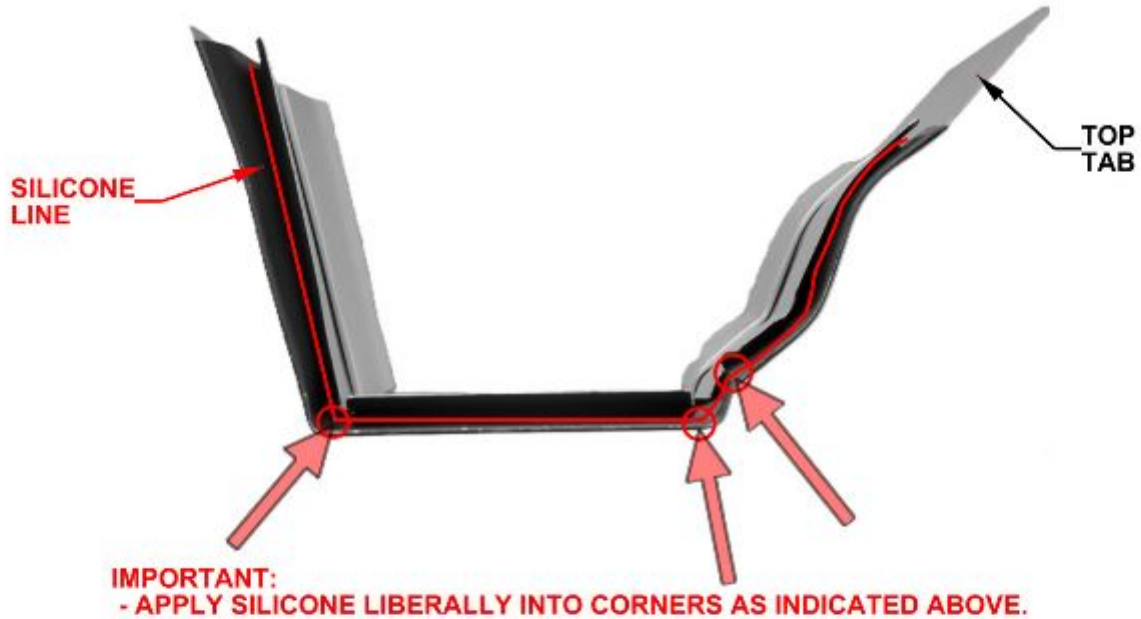

WAIT APPROXIMATELY 45 MINUTES FOR SILICONE TO BECOME TACKY.  
AFTER 24 HOURS, SILICONE HAS CURED AND CAN HOLD WATER

# OFFSET ORIENTATION

TO ENSURE WATER FLOWS PROPERLY, IT IS IMPORTANT TO ORIENT DOWNSPOUT PIPING CORRECTLY. STARTING AT THE TOP, DOWNSPOUTS MUST FEED INTO THE NEXT SECTION AS SHOWN.

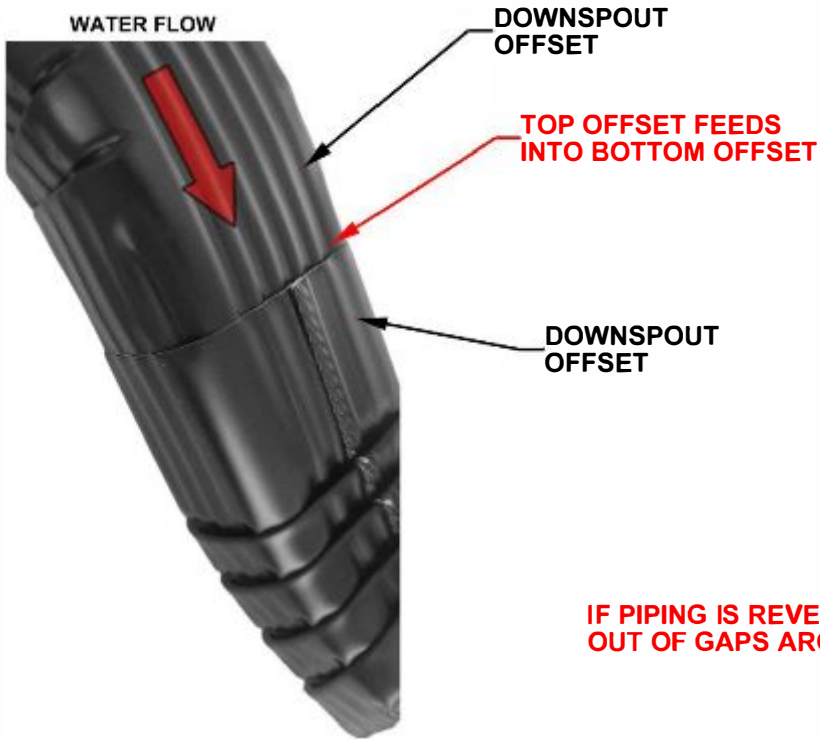

IF PIPING IS REVERSED, WATER WILL RUN OUT OF GAPS AROUND JOINTS

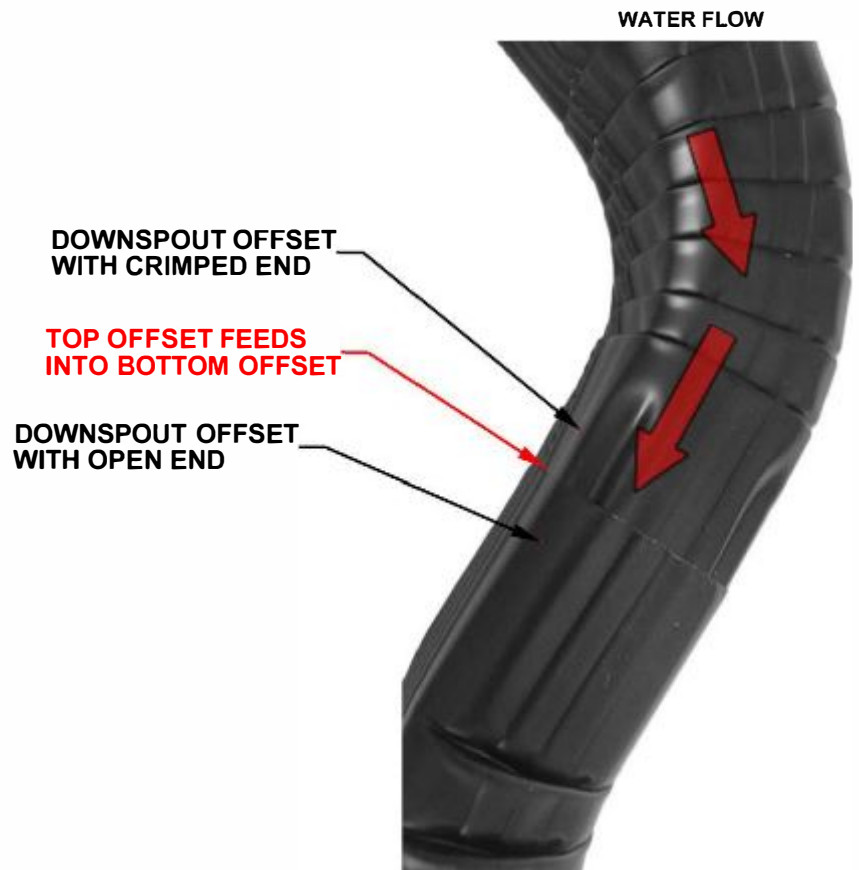

# STEP 1 - GUTTER ASSEMBLY

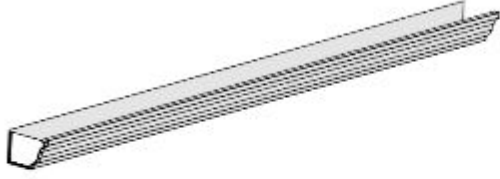

A4M06907 LEFT GUTTER  
(x1)

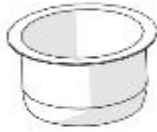

A4M04761 DOWNSPOUT OUTLET  
(x1)

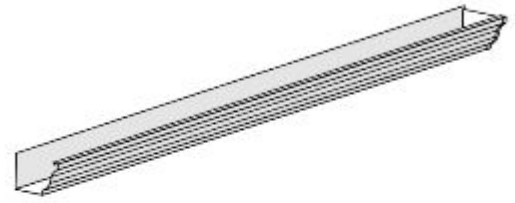

A4M06906 RIGHT GUTTER  
(x1)

- APPLY A BEAD OF SILICONE AROUND THE BOTTOM LIP OF THE DOWNSPOUT OUTLET AND PLACE OUTLET INSIDE GUTTER.

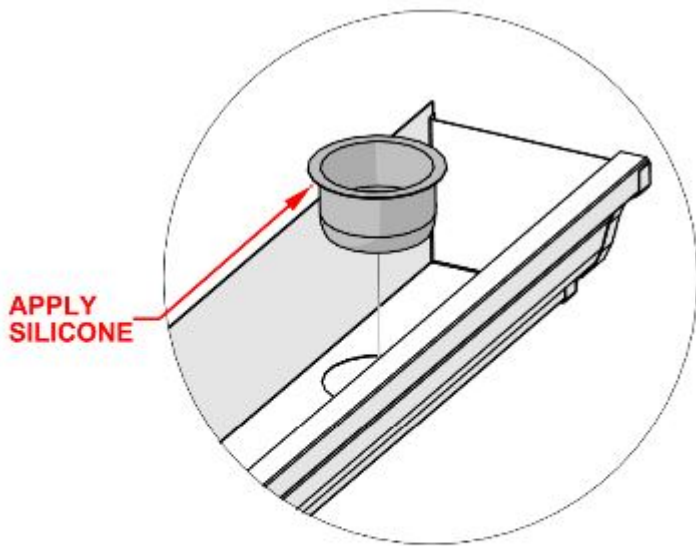

TIP: PRESSURE MAY NEED TO BE APPLIED TO GET OUTLET INTO POSITION. USE A WET FINGER TO FLATTEN SILICONE AFTER INSTALL.

4761 (x1)  
DOWNSPOUT OUTLET

6907 (x1)  
LEFT GUTTER

## STEP 2 - GUTTER ASSEMBLY

QTY	PART NUMBER	DESCRIPTION
2	H101480	SCREW SELF TAPPING #9x1 BLK

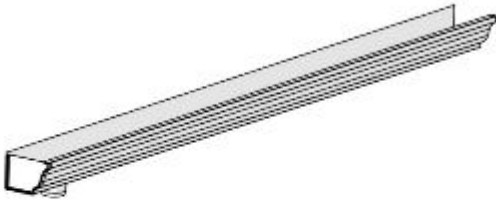

LEFT GUTTER W/ OUTLET - STEP 1

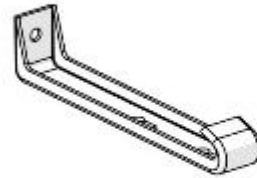

A4M04759 GUTTER HANGER  
(x2)

- SLIDE GUTTER BEHIND DRIP EDGE AND UP TO ROOF LINE.
- FLUSH THE END OF THE GUTTER WITH THE END OF THE GAZEBO
- ATTACH THE FIRST HANGER APPROXIMATELY 4" [100mm] FROM THE EDGE OF THE GUTTER.
- ATTACH THE SECOND HANGER AT THE 7TH ROOF RIB.
- PRE-DRILL 1/8" [3mm] PILOT HOLES FOR EASE OF ASSEMBLY.
- USE A CLAMP TO HOLD GUTTER FOR EASE OF ASSEMBLY.

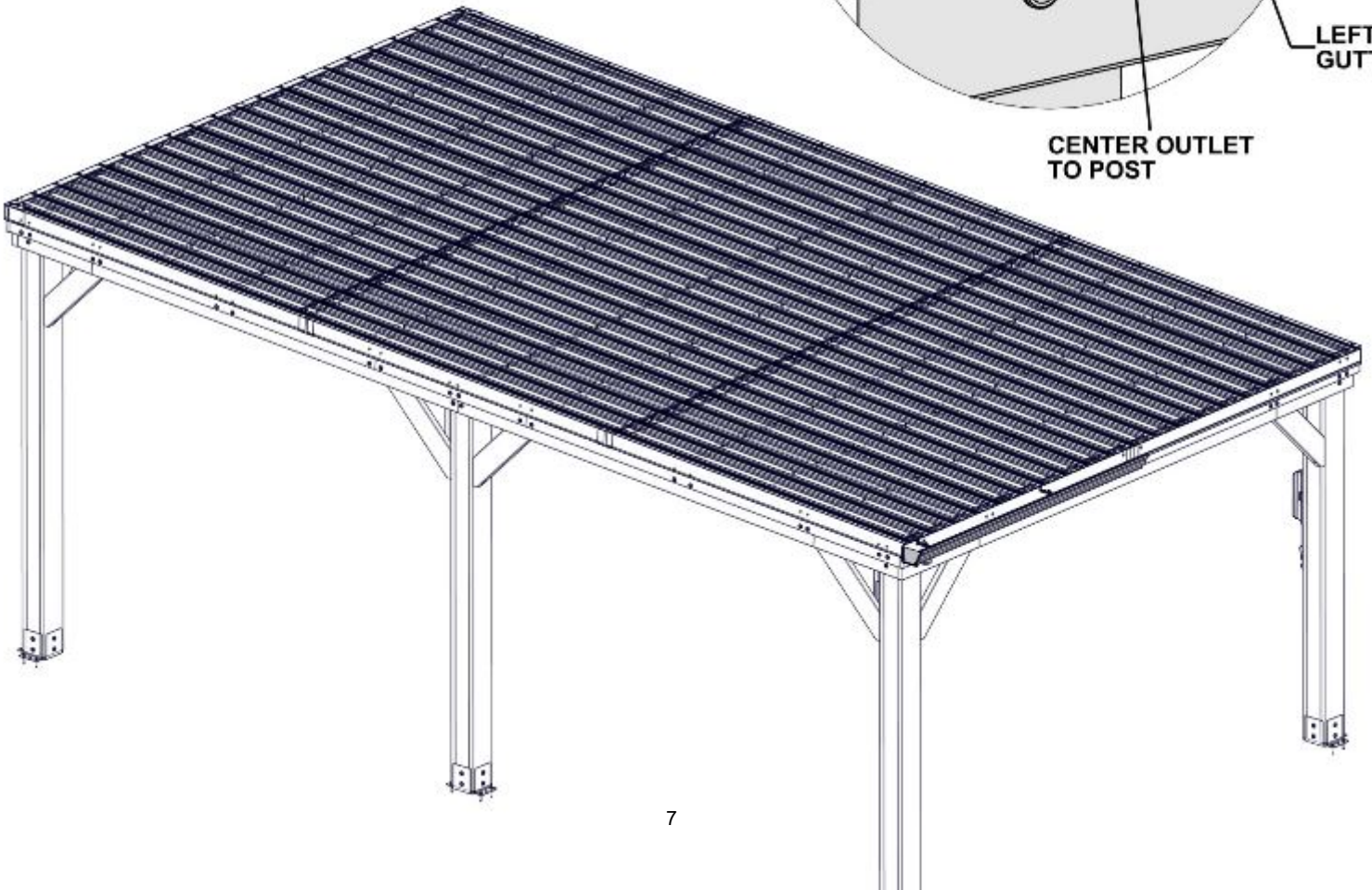
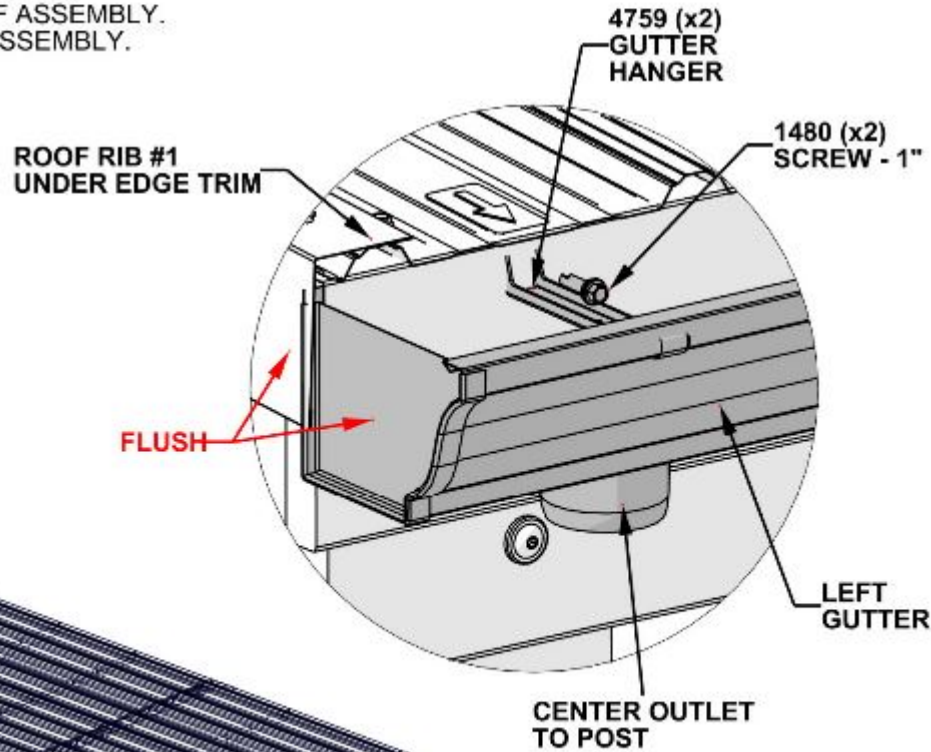

# STEP 3 - GUTTER ASSEMBLY

QTY	PART NUMBER	DESCRIPTION
2	H101480	SCREW SELF TAPPING #9x1 BLK

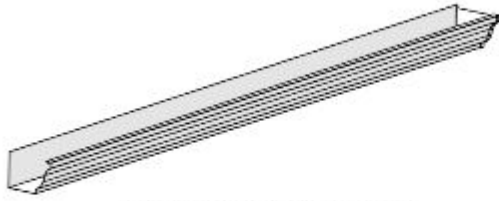

A4M06906 RIGHT GUTTER (x1)

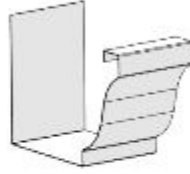

A4M04765 GUTTER SPLICE (x1)

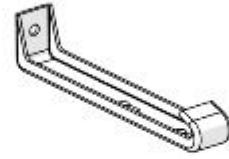

A4M04759 GUTTER HANGER (x2)

- SLIDE GUTTER BEHIND DRIP EDGE AND UP TO ROOF LINE.
- FLUSH THE END OF THE GUTTER WITH THE END OF THE GAZEBO
- ATTACH THE FIRST HANGER APPROXIMATELY 4" [100mm] FROM THE EDGE OF THE GUTTER.
- ATTACH THE SECOND HANGER AT THE 7TH ROOF RIB.
- PRE-DRILL 1/8" [3mm] PILOT HOLES FOR EASE OF ASSEMBLY.
- USE A CLAMP TO HOLD GUTTER FOR EASE OF ASSEMBLY.

**APPLY SILICONE TO SPLICE GROOVE BEFORE INSERTING INTO GUTTER**

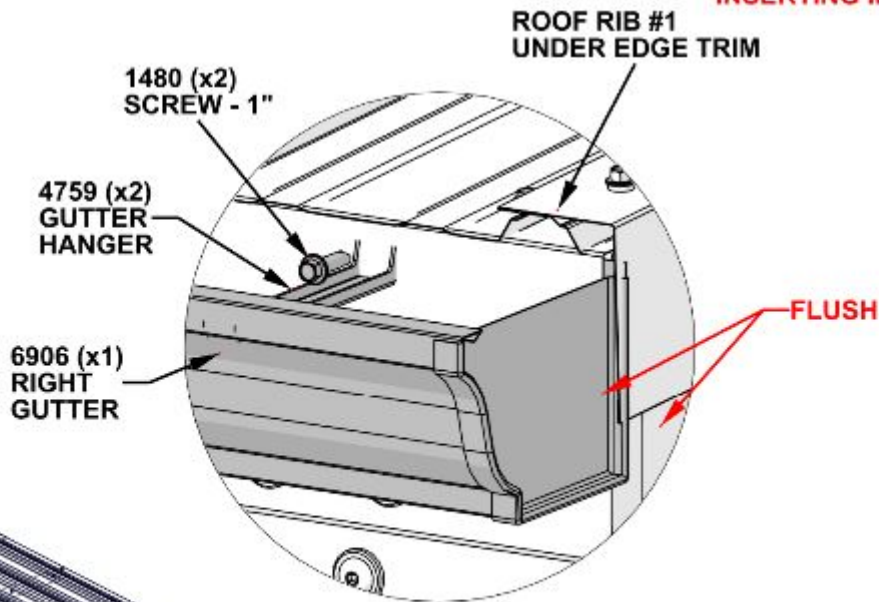
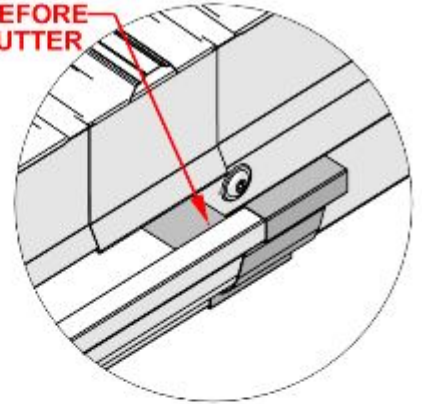

**APPLY SILICONE TO SPLICE GROOVE BEFORE INSERTING GUTTER INTO SPLICE**

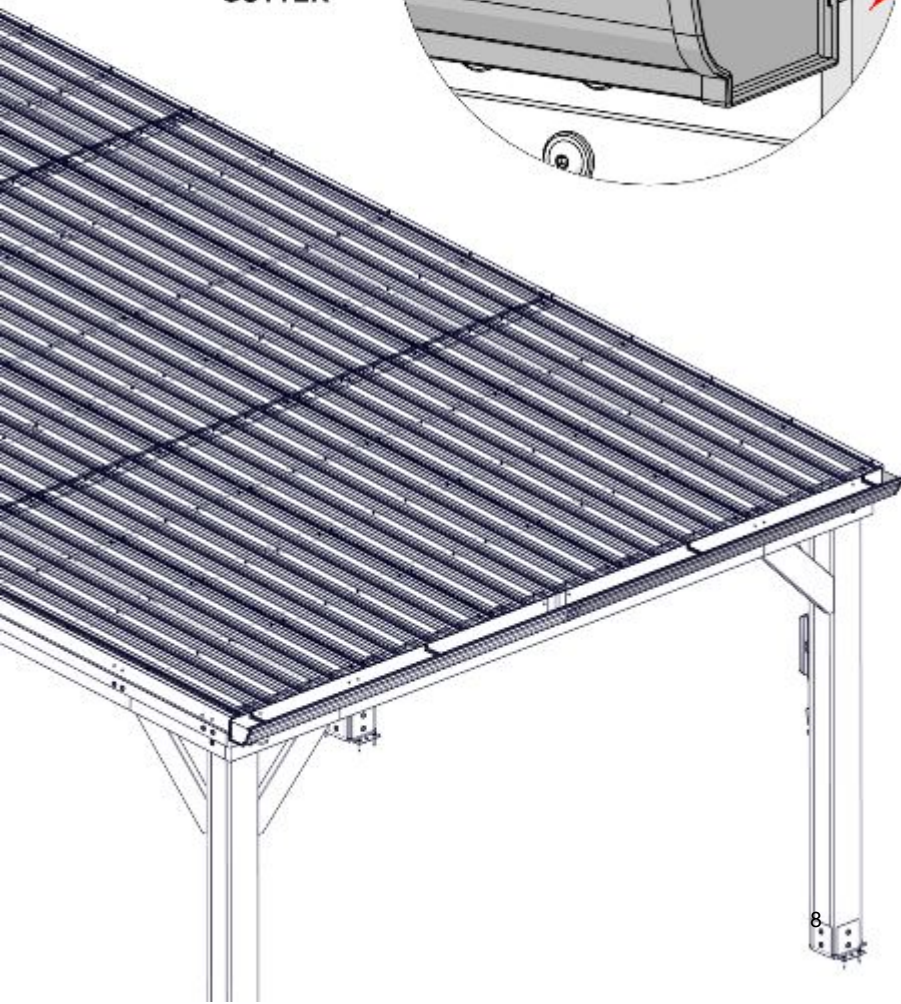
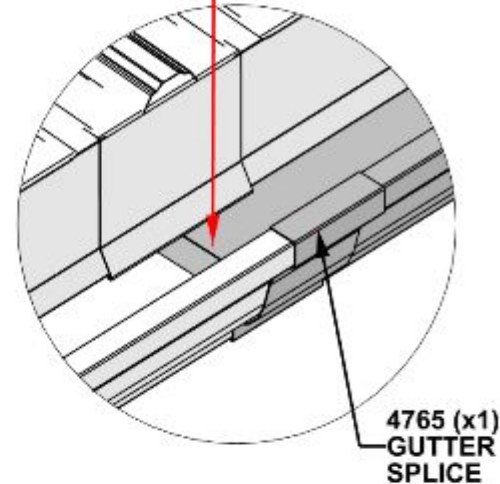

# STEP 4 - GUTTER ASSEMBLY

QTY	PART NUMBER	DESCRIPTION
4	H101480	SCREW SELF TAPPING #9x1 BLK

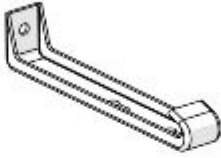

A4M04759 GUTTER HANGER  
(x4)

- ATTACH ALL REMAINING GUTTER HANGERS
- EVENLY SPACE HANGERS AS SHOWN APPROXIMATELY 19-5/8" [500mm] APART

19-5/8" [500mm]

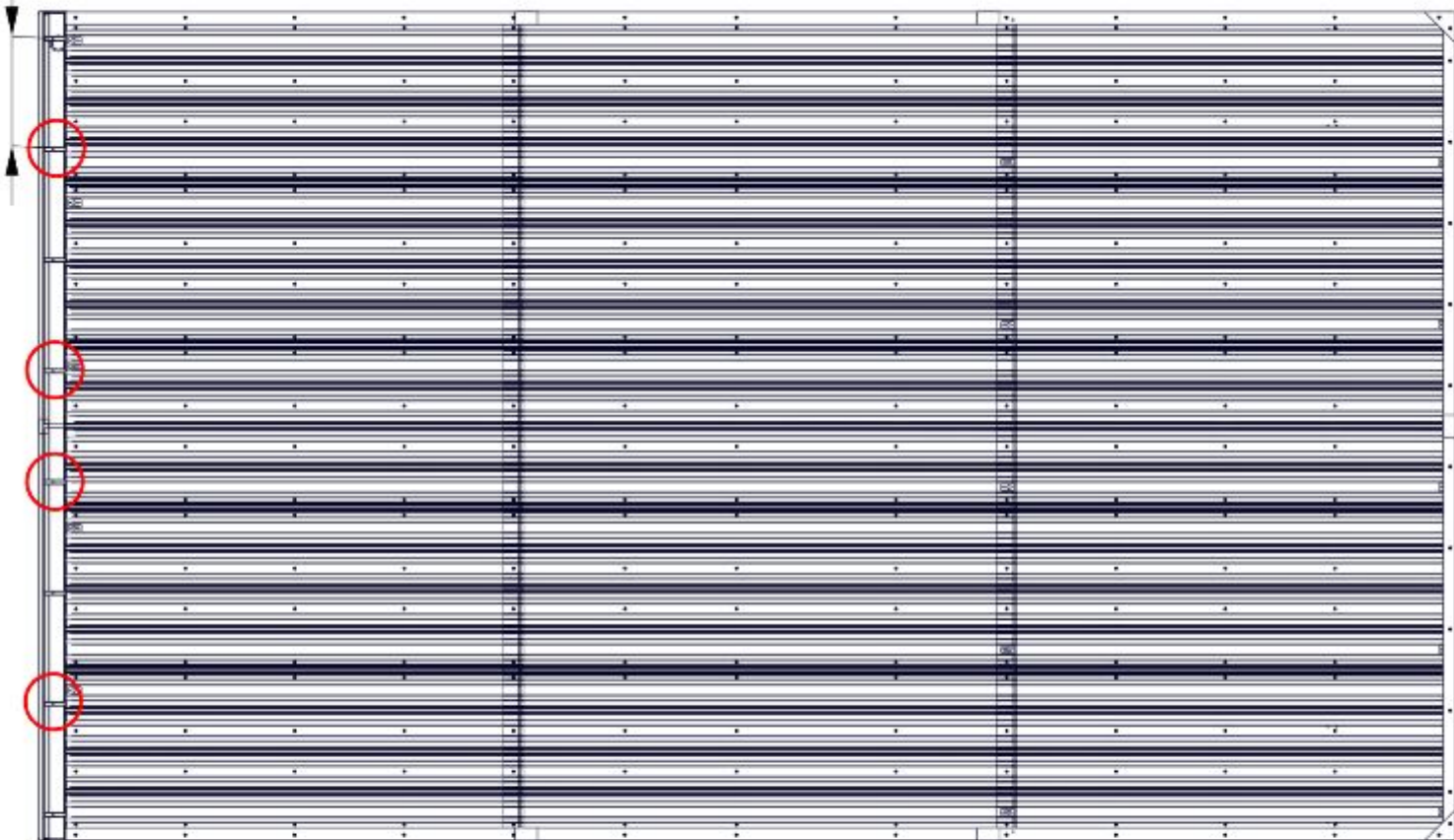

# STEP 5 - GUTTER ASSEMBLY

QTY	PART NUMBER	DESCRIPTION
4	H101205	SCREW PWH 8x15x3/4 BLK

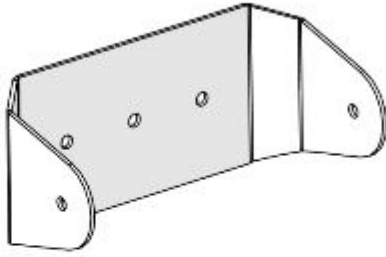

A4M04782 DOWNSPOUT CLIP  
(x2)

- IT IS IMPORTANT TO CENTER 4782 CLIP AND HARDWARE ON POST AS SHOWN.
- ATTACH GUTTER CLIP APPROXIMATELY 14" [350mm] AND 73" [1850mm] OFF THE GROUND.

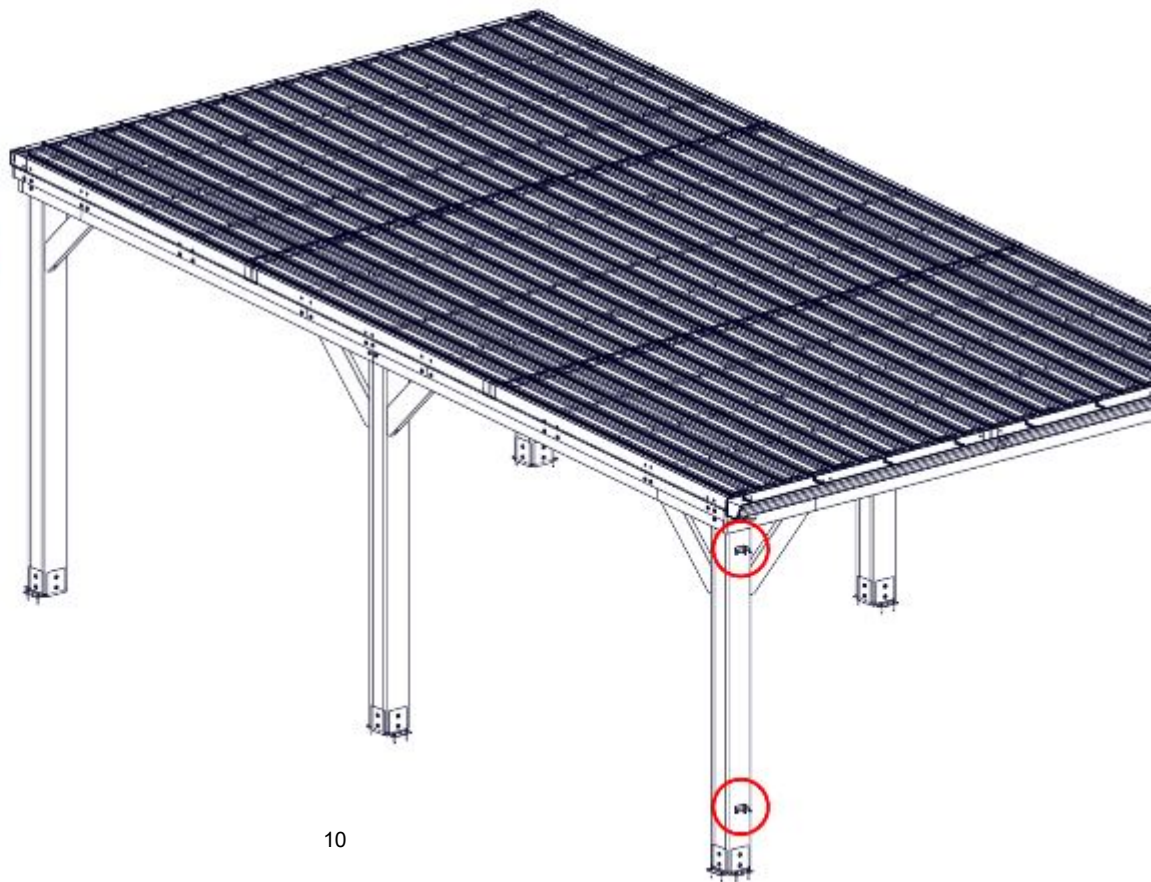
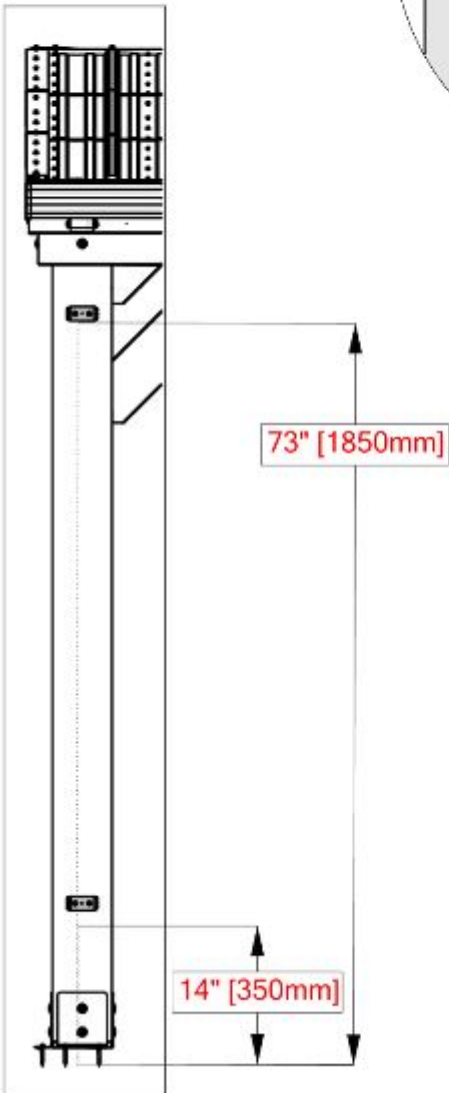
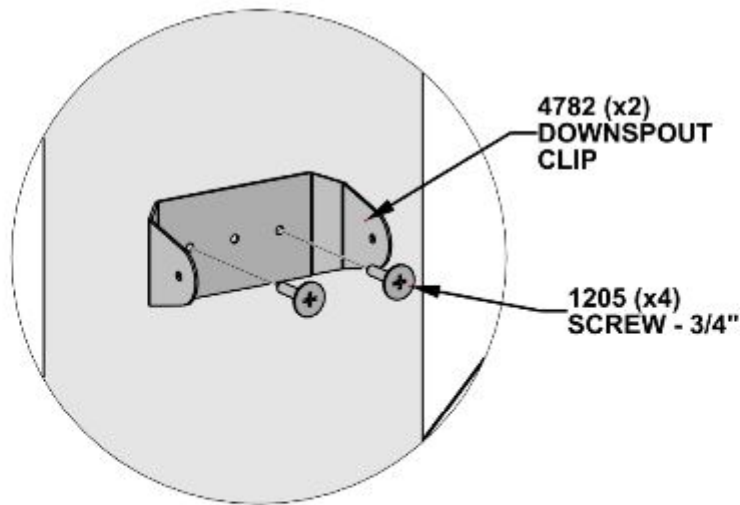

# STEP 6 - GUTTER ASSEMBLY



A4M06238 DOWNSPOUT ELBOW - LONG  
(x1)



A4M04783 DOWNSPOUT - 60°  
(x1)

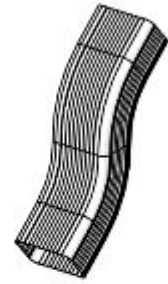

A4M06822 DOWNSPOUT OFFSET - 3°  
(x1)

- INSERT TAPERED ENDS INTO LARGER ENDS AS SHOWN.
- NOTE ORIENTATION OF DOWNSPOUT OFFSET. SEE DOWNSPOUT OFFSET PAGE FOR DETAIL.

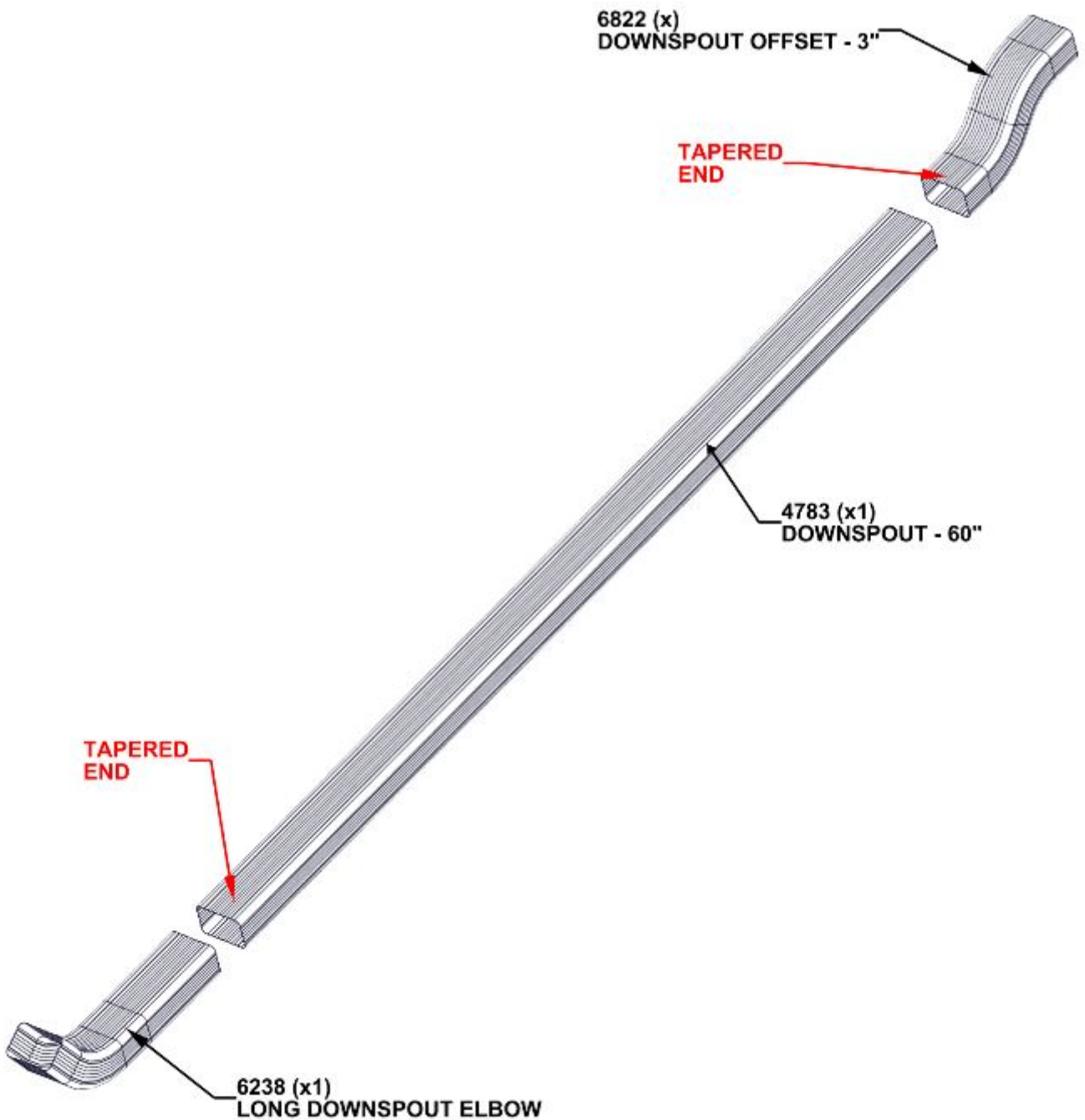

# STEP 7 - GUTTER ASSEMBLY

QTY	PART NUMBER	DESCRIPTION
1	H101414	SCREW SELF PIERCING #8x1/2 BLK



DOWNSPOUT ASSEMBLY - STEP 6

- SLIDE DOWNSPOUT ASSEMBLY OVER GUTTER OUTLET AND ATTACH WITH HARDWARE PROVIDED.
- NOTE GUTTER WILL NOT EXTEND TO GROUND, THERE WILL BE FLOATING SPACE.

1414 (x1)  
SCREW - 1/2"

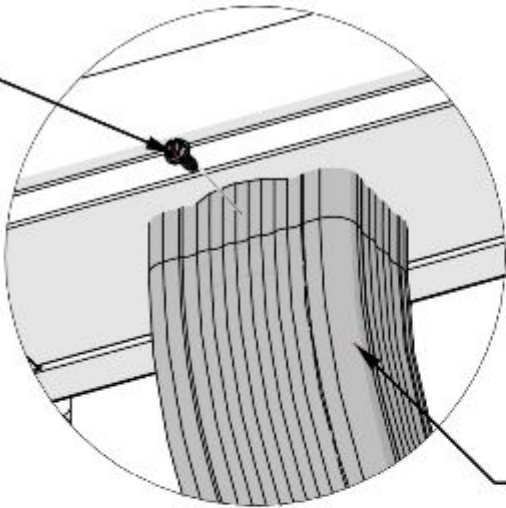

DOWNSPOUT ASSEMBLY

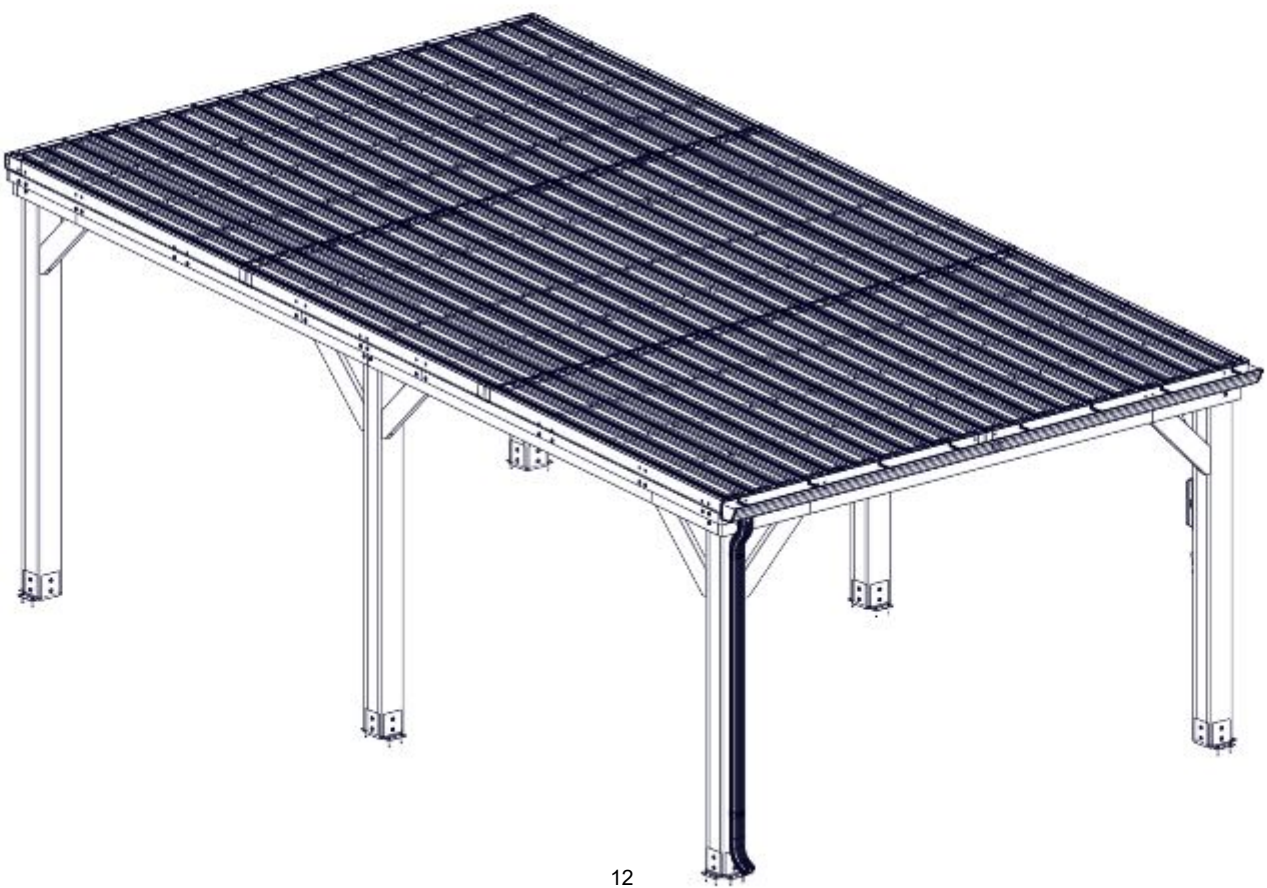

# STEP 8 - GUTTER ASSEMBLY

QTY	PART NUMBER	DESCRIPTION
4	H101414	SCREW SELF PIERCING #8x1/2 BLK

- FASTEN DOWNSPOUT CLIP TO DOWNSPOUT USING HARDWARE PROVIDED.

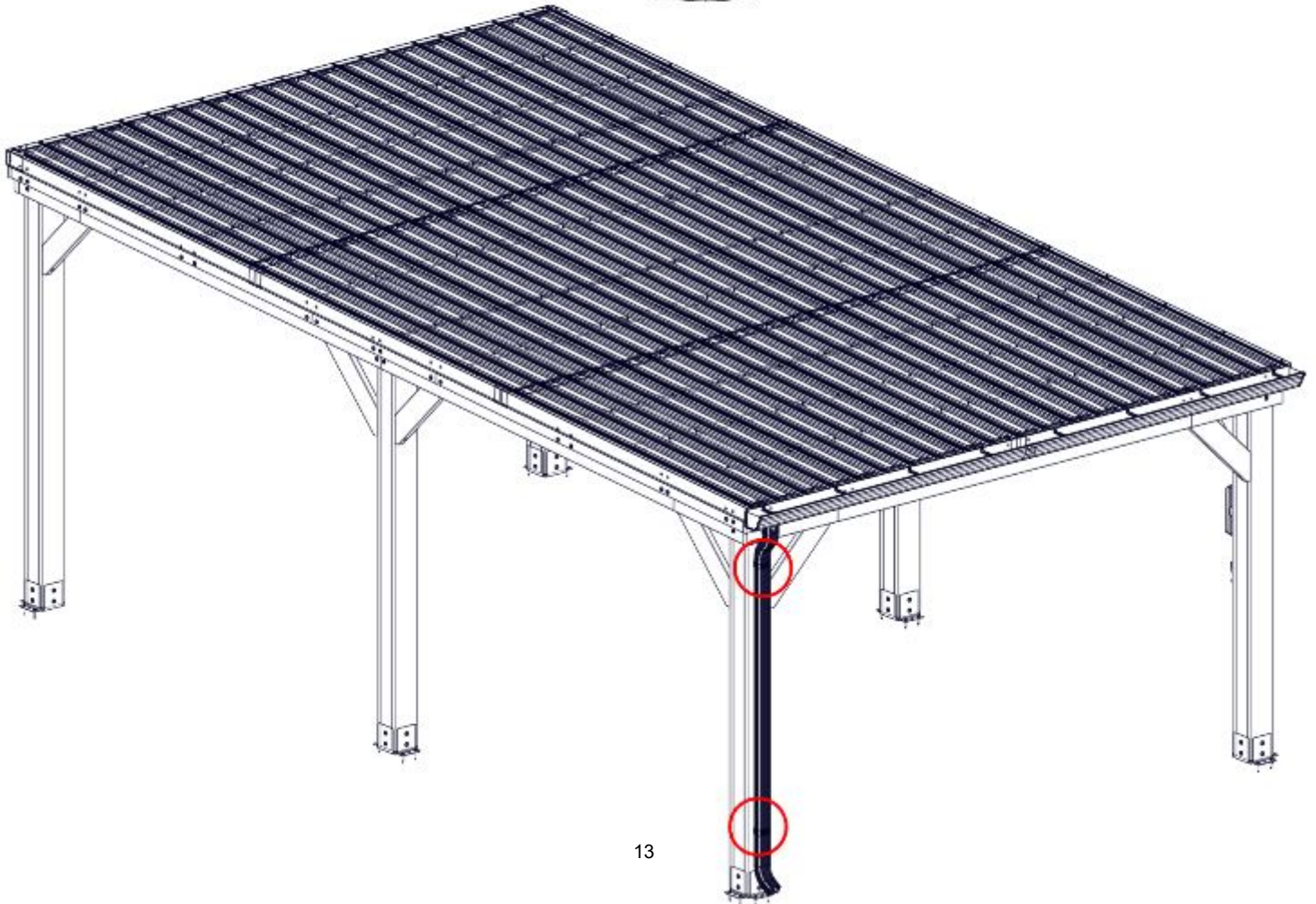
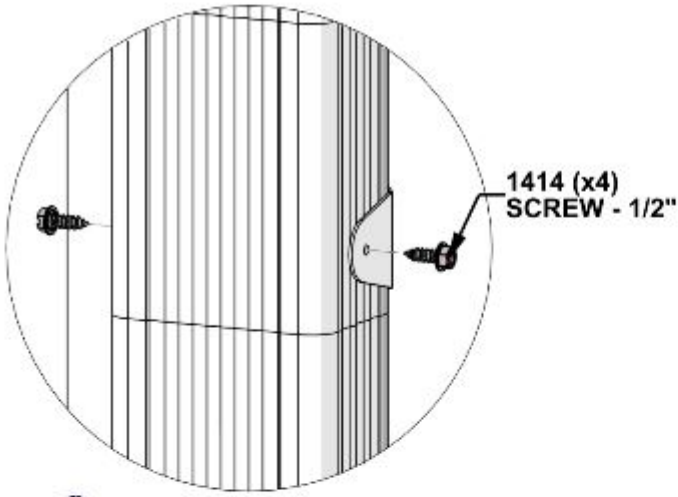

# STEP 9 - GUTTER ASSEMBLY

- NOTE:**
- IT IS RECOMMENDED TO APPLY A SECOND BEAD OF SILICONE AT THE GUTTER SPLICE POSITION.
  - BY WETTING ONES FINGER, GENTLY PUSH CAULK INTO SPLICE TAB AND CORNERS TO ENSURE PROPER SEALING.
  - SEE BELOW FOR LOCATION.

