



Manufactured by:
Backyard Discovery
3305 Airport Drive, Pittsburg, KS 66762
800-856-4445

Basepoint Business Centre: Rivermead Drive, Westlea, Swindon SN5 7EX Phone: 0800-118-2476
J.P. Coenstraat 7, The Bridge, The Hague, 2595 WP, Netherlands Phone: 08005678990

18x10 EVANSTON STEEL WALL-MOUNTED LOUVERED PERGOLA

MODEL #: 2407138B



WARNING

Cancer and Reproductive Harm
www.P65Warnings.ca.gov



Please visit www.backyarddiscovery.com
For the most up to date assembly manual, to register your product, or to order
replacement parts Para obtener instrucciones en español, visite
www.backyarddiscovery.com



EASY STEP-BY-STEP
3D INTERACTIVE INSTRUCTIONS
DOWNLOAD THE FREE APP



OWNER'S MANUAL - BASIC SETUP DIMENSIONS & ASSEMBLY NOTES

It is critically important that you start with square and level footings, concrete pad or deck to attach your structure.

- Pay close attention to the items needed for each step. Make sure you are using the correct hardware for each step. Using incorrect hardware may result in improper assembly
- Remember to double check for underground utilities and overhead electrical lines

Post mounts are provided with your structure which allows you to permanently install your structure to a pre-existing or new wood or concrete surface. See Anchor Instructions for further details and recommendations.

- The hardware to attach the post mounts to the structure is included.
- The hardware to mount the structure permanently to a concrete surface is included.
- The hardware to attach the structure permanently to a house is included.
- The hardware to mount the structure permanently to a wood deck is NOT included and will need to be purchased separately. You must ensure there is ample structural support under the deck before permanently attaching.

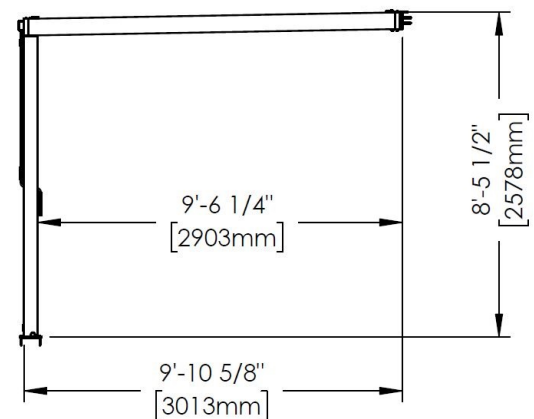
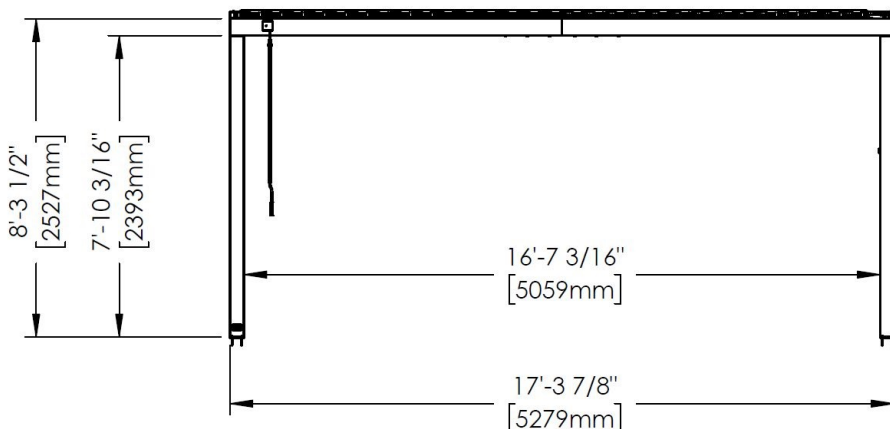
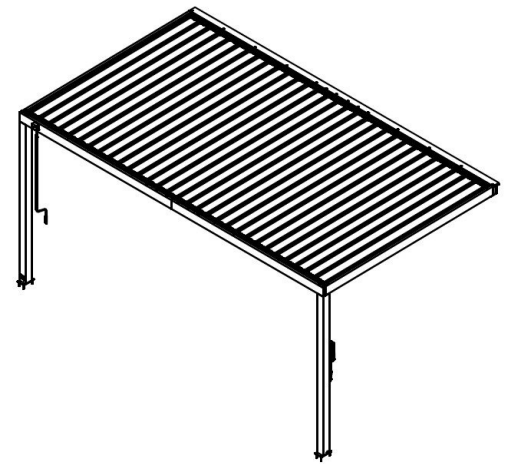
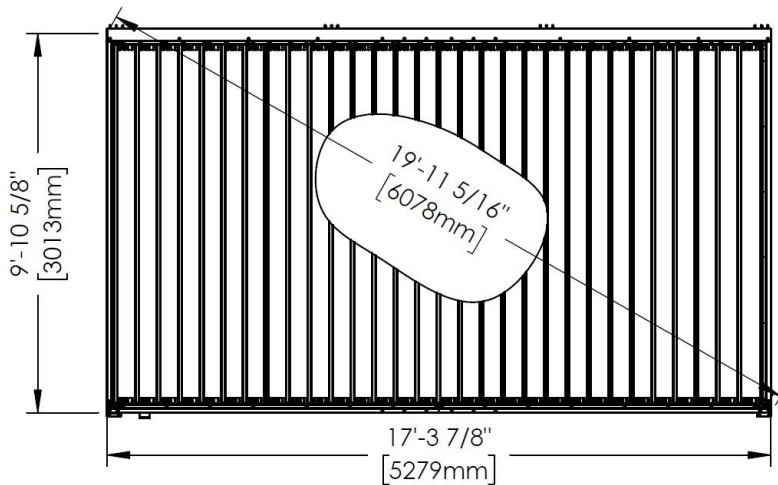

OWNER'S MANUAL - ANCHORING LAYOUT

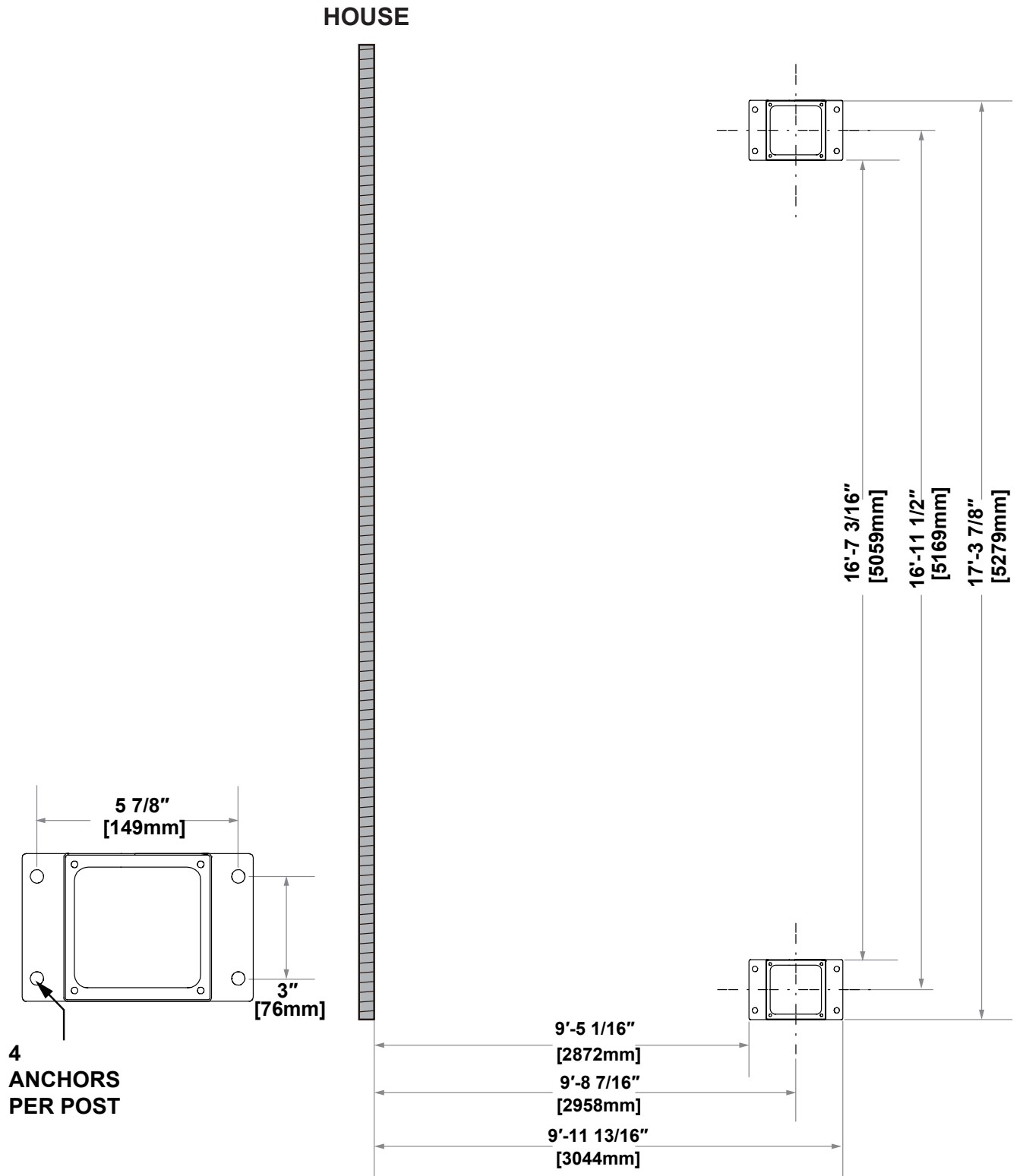

NOTE: DIMENSIONS ARE TO ANCHOR PLATE ON BOTTOM OF POST EXCEPT WHERE NOTED.

OWNER'S MANUAL - PARTS IDENTIFICATION

METAL COMPONENTS (NOT TO SCALE)



B01 BEAM - A4M03480
(x1) 1 7/16"x5 1/4"x114 7/8" (36x134x2918)



B02 BEAM - A4M03479
(x1) 1 7/16"x5 1/4"x114 7/8" (36x134x2918)



B03 BEAM - A4M05897
(x1) 1 7/16"x5 1/4"x103 7/8" (36x134x2639)



B04 BEAM - A4M05894
(x1) 1 7/16"x5 1/4"x103 7/8" (36x134x2639)

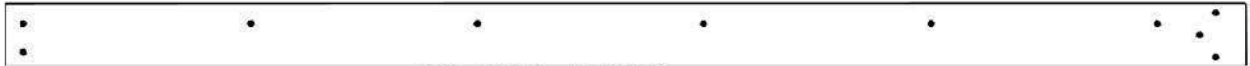

B05 BEAM - A4M05898
(x1) 1 7/16"x5 1/4"x103 7/8" (36x134x2639)



B06 BEAM - A4M05895
(x1) 1 7/16"x5 1/4"x103 7/8" (36x134x2639)

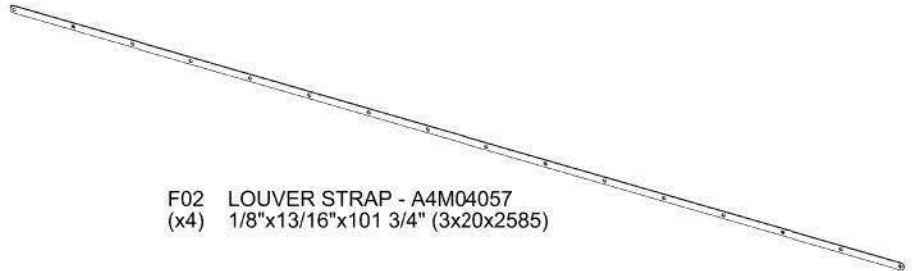

F02 LOUVER STRAP - A4M04057
(x4) 1/8"x13/16"x101 3/4" (3x20x2585)

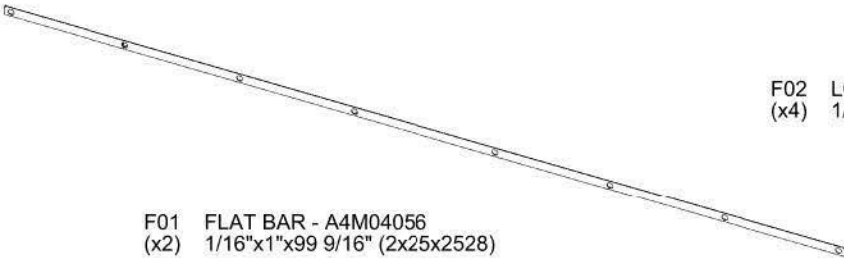

F01 FLAT BAR - A4M04056
(x2) 1/16"x1"x99 9/16" (2x25x2528)

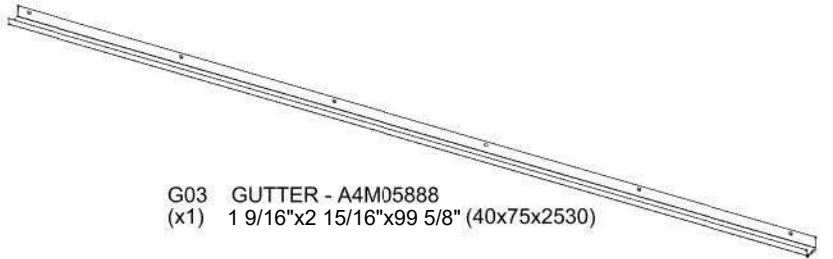

G03 GUTTER - A4M05888
(x1) 1 9/16"x2 15/16"x99 5/8" (40x75x2530)

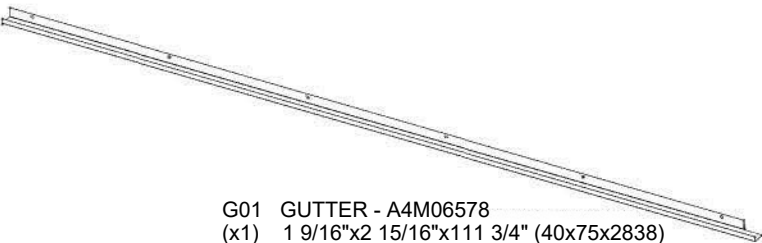

G01 GUTTER - A4M06578
(x1) 1 9/16"x2 15/16"x111 3/4" (40x75x2838)

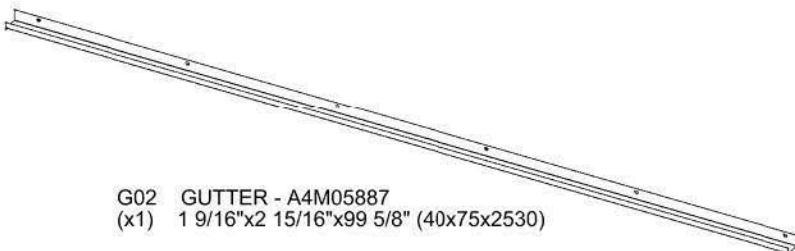

G02 GUTTER - A4M05887
(x1) 1 9/16"x2 15/16"x99 5/8" (40x75x2530)

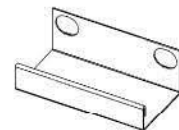

G05 GUTTER SPLICE - A4M05889
(x2) 1 7/16"x3 1/16"x3 15/16" (36x77.5x100)

OWNER'S MANUAL - PARTS IDENTIFICATION

METAL COMPONENTS (NOT TO SCALE)

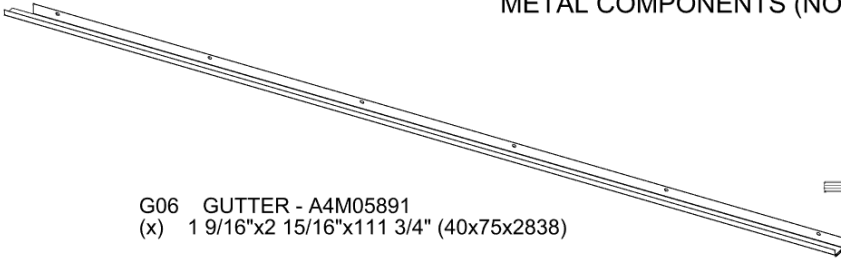

G06 GUTTER - A4M05891
(x) 1 9/16"x2 15/16"x111 3/4" (40x75x2838)

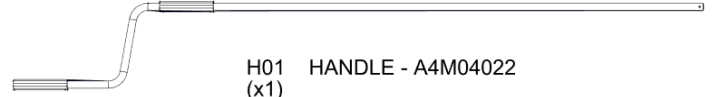

H01 HANDLE - A4M04022
(x1)

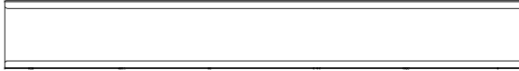

J1 SPLICE BRACKET - A4M02230
(x1) 1 5/16"x5 3/16"x39 3/8" (33.2x131.2x1000)

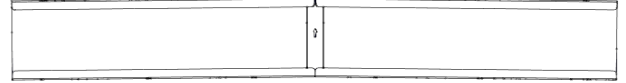

J2 SPLICE BRACKET ASSY - A4M06579
(x1) 39 1/2"x5 1/8"x1 1/4" (32x131.2x1003)



K1 WEATHER STRIP - A6P01200
(x1) 1/16"x3 15/16"x199 9/16" (1.6x100x5068)

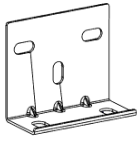

K03 CENTER WALL BRACKET - A4M05899
(x2) 2 11/16"x5 3/16"x6" (69x131x152)

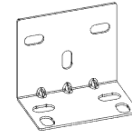

K04 CORNER WALL BRACKET - A4M03483
(x2) 3 15/16"x5 1/8"x6" (99x131x152)

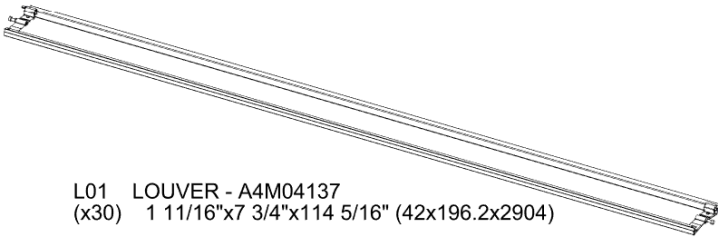

L01 LOUVER - A4M04137
(x30) 1 11/16"x7 3/4"x114 5/16" (42x196.2x2904)

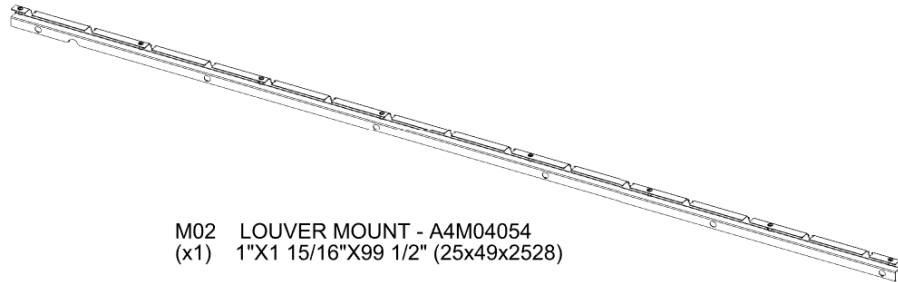

M02 LOUVER MOUNT - A4M04054
(x1) 1"x1 15/16"x99 1/2" (25x49x2528)

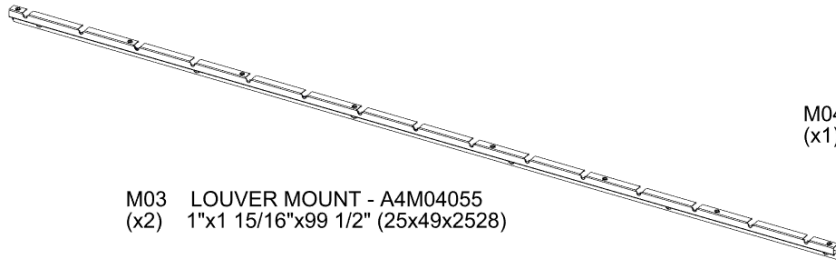

M03 LOUVER MOUNT - A4M04055
(x2) 1"x1 15/16"x99 1/2" (25x49x2528)

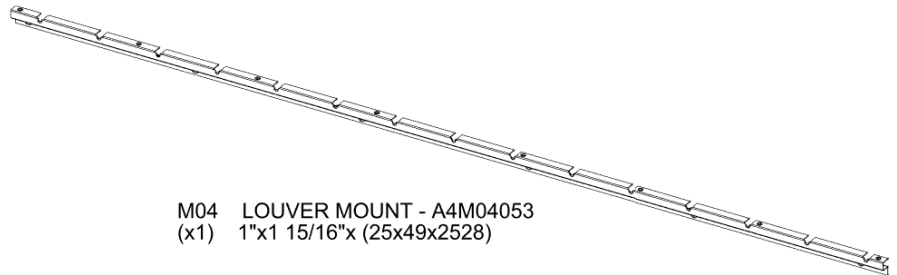

M04 LOUVER MOUNT - A4M04053
(x1) 1"x1 15/16"x (25x49x2528)

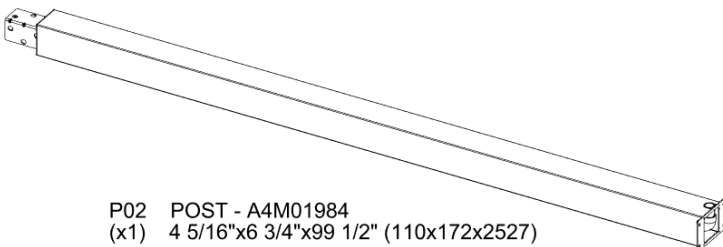

P02 POST - A4M01984
(x1) 4 5/16"x6 3/4"x99 1/2" (110x172x2527)

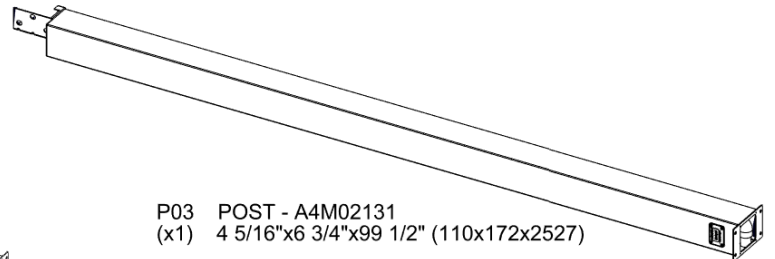

P03 POST - A4M02131
(x1) 4 5/16"x6 3/4"x99 1/2" (110x172x2527)

OWNER'S MANUAL - PARTS IDENTIFICATION

METAL COMPONENTS (NOT TO SCALE)

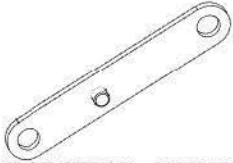

F03 LINKAGE STRAP - A4M02229
(x1) 1/2"x11/16"x3 13/16" (13x17x97)

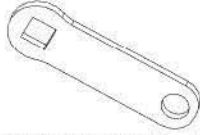

F04 LINKAGE STRAP - A4M02225
(x1) 1/8"x13/16"x2 5/8" (3x20x66)

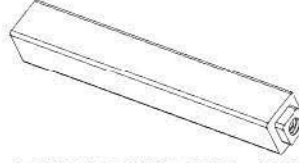

F05 LOUVER DRIVE AXLE - A4M02226
(x1) 1/2"x1/2"x3 3/4" (13.0x13.0x95)



F06 SPACER - A4M02227
(x1) 1/16"x2 3/16"x2 3/4" (1.5x56x70)

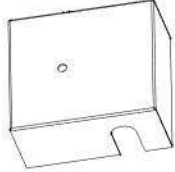

F07 COVER - A4M02228
(x1) 1 9/16"x2 7/8"x3 1/4" (39.5x73x82)

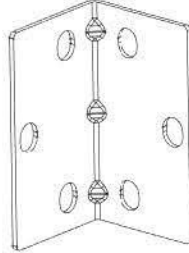

CB01 POST BRACKET - A4M04063
(x2) 2 15/16"x2 15/16"x5 1/4" (74.5x74.5x134)

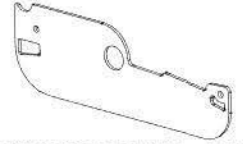

L03 LOUVER SIDE PLATE - A4M04138
(x59) 1/16"x2 3/16"x6 9/16" (2x55x167)



L02 LOUVER DRIVE SIDE PLATE - A4M04139
(x1) 1/16"x2 3/16"x6 9/16" (2x55x167)

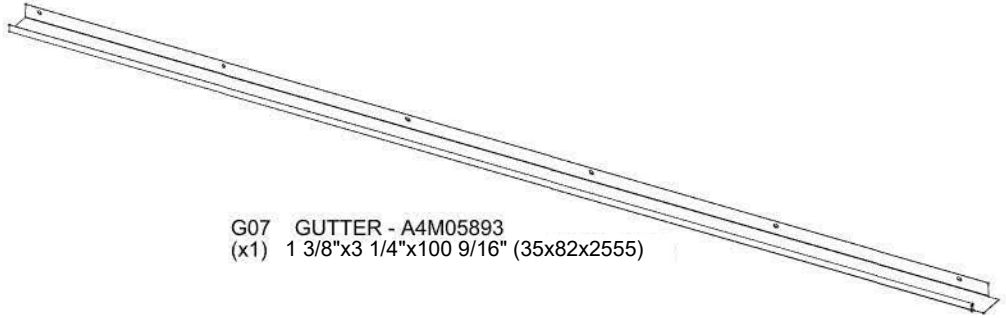

G07 GUTTER - A4M05893
(x1) 1 3/8"x3 1/4"x100 9/16" (35x82x255)

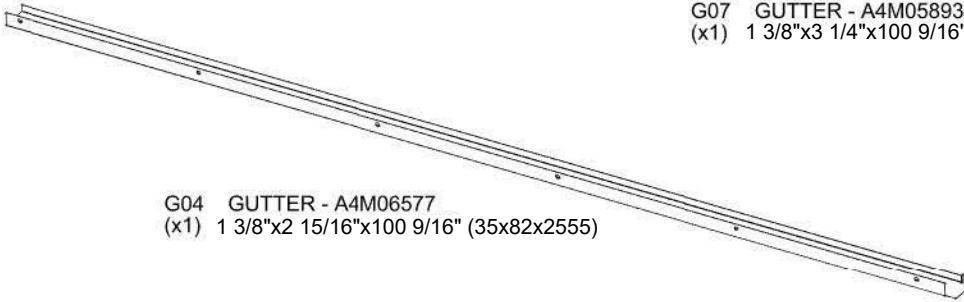

G04 GUTTER - A4M06577
(x1) 1 3/8"x2 15/16"x100 9/16" (35x82x255)

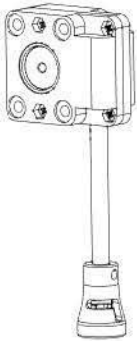

9205413 ELECTRICAL ENCLOSURE
(x1)

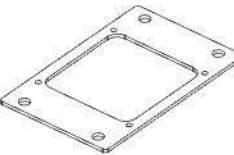
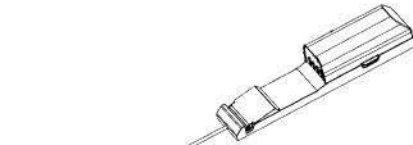

A4M04024 SHIM
(x4)



A6P00796 SILICONE
(x1)

L04 LOUVER MECHANISM - A4M02132
(x1)



T01 TEMPLATE - W4L20947
(x2) 1/8"x5 1/2"x61 7/8" (3x140x1571)



T02 TEMPLATE - W4L20948
(x1) 1/8"x5 1/2"x86 1/16" (3x140x2186)

OWNER'S MANUAL - PARTS IDENTIFICATION

Hardware Components

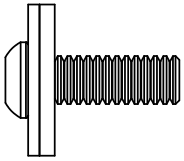

H101202 TORX PAN HEAD 1/4-20x3/4 ASSY
(x148) 1/4-20x3/4 ASSY

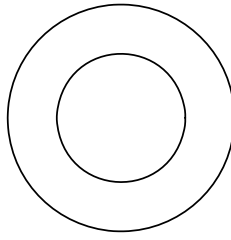

H100497 WASHER FLAT BLK
(x12) 17x30

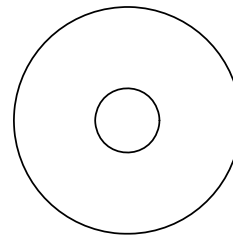

H101316 WASHER FLAT B LK
(x10) 8.5X30

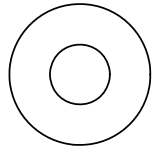

H100630 WASHER FLAT BLK
(x8) 8x19

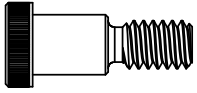

H101189 LOW PROFILE SHOULDER BOLT BLK
(x2) 1/4-20x3/8

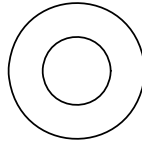

H100474 WASHER FLAT BLK
(x5) 9x18

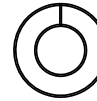

H100774 WASHER SPLIT BLK
(x1) 1/4

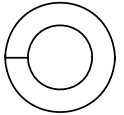

H100477 WASHER SPLIT BLK
(x10) 5/16

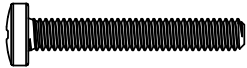

H101187 BOLT PPH BLK
(x1) 8-32x1 1/8



H100653 NUT LOCK BLK
(x2) 1/4



H101101 TORX PAN HEAD BLK
(x1) 1/4-20x3/4"

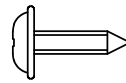

H100408 SCREW PWH BLK
(x120) 8x1/2

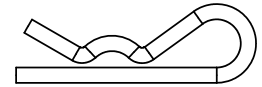

H101161 COTTER PIN
(x60)

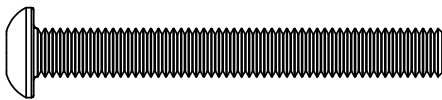

H101126 TORX PAN HEAD BLK
(x4) 1/4-20x2 1/8"

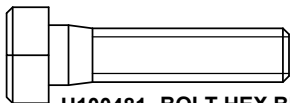

H100481 BOLT HEX BLK
(x10) 5/16x1 1/4

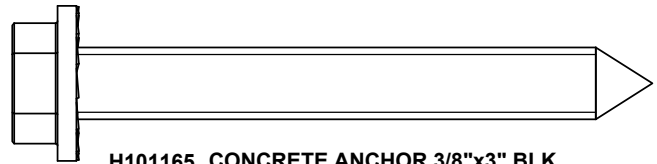

H101165 CONCRETE ANCHOR 3/8"x3" BLK
(x12) 3/8x3

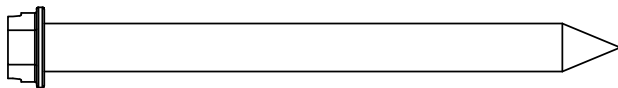

H101305 CONCRETE ANCHOR 1/4"x3"
(x8) 1/4x3



H101310 LAG HEX BLK
(x12) 3/8x3

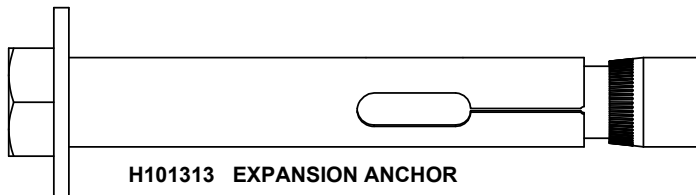

H101313 EXPANSION ANCHOR
(x12)

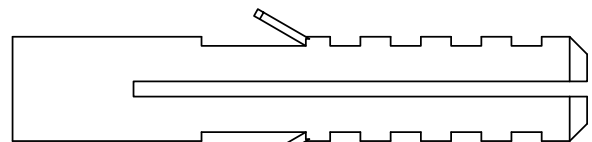

H101311 PLASTIC ANCHOR
(x12) 3/8x3



H101230 BOLT WH S.S.
(x8) 5/16x6

OWNER'S MANUAL - PARTS IDENTIFICATION

Hardware Components

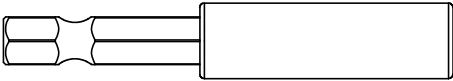

H101100 MAGNETIC DRIVER
(x1)

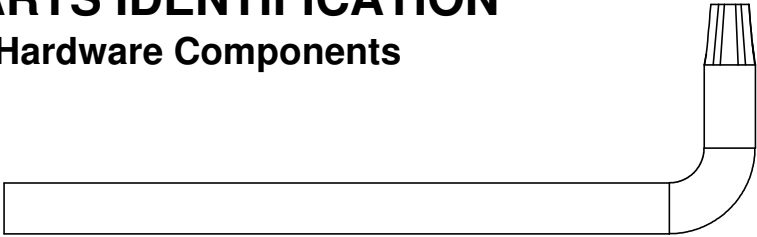

H100114 TORX WRENCH
(x1) T-30

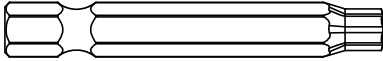

H100147 TORX BIT
(x1) T-30

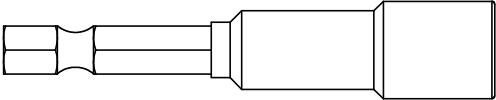

H101106 SOCKET DRIVER
(x1)

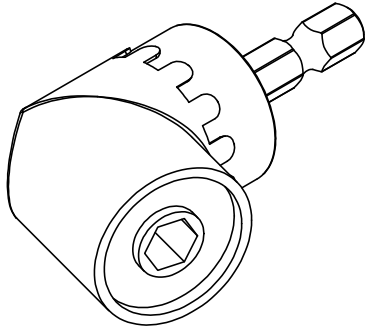

H101114 RIGHT ANGLE DRILL ADAPTER
(x1)

PRE-ASSEMBLY STEP 1 - SORTING PARTS

It is critical for ease of assembly that you take the time to sort and organize the parts and hardware.

METAL PARTS:

- Organize metal parts by the three-digit, alpha-numeric number stamped on each part (ex. P01).
- If there are multiple parts with the same stamped number, stack those pieces together.
- Stamps can be found on the flat surface of the parts or on the end of the parts.
- Allow yourself plenty of room - the parts can take up a significant amount of space.

**NOTE: CARTONS ARE NOT ORGANIZED BY PART NUMBER.
IT IS RECOMMENDED TO LEAVE LOUVER ASSEMBLIES IN BOX UNTIL NEEDED.**

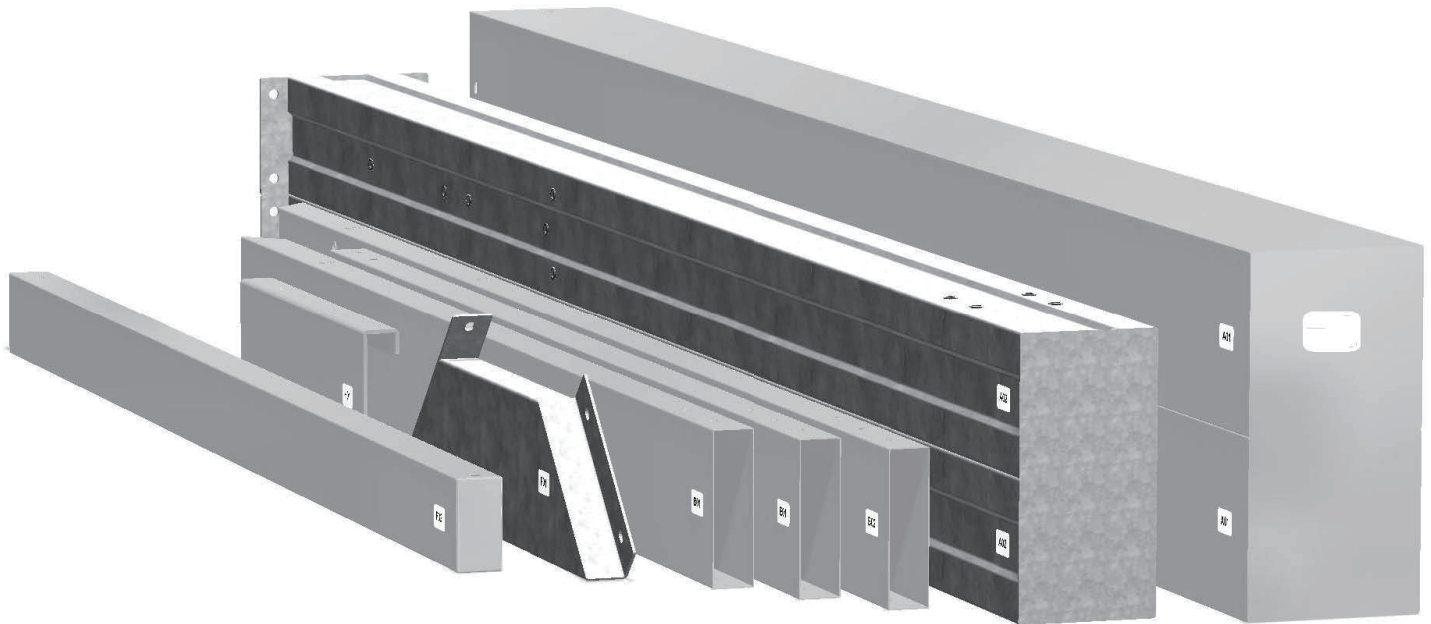

HARDWARE PARTS:

- We recommend that you have a separate table to organize the hardware.
- Hardware bags are printed with a seven-digit, alpha-numeric part number.
- You can organize your hardware by part number or group by hardware type (e.g. bolts, nuts, etc.).
- During assembly you only need to reference the last four digits of the number.

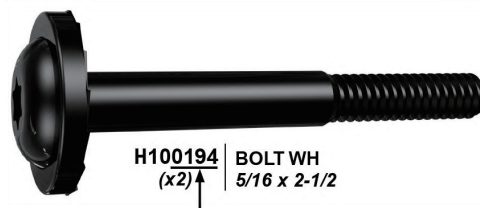

PRE-ASSEMBLY STEP 2 - TOOLS REQUIRED



Cordless Drill or
Electric Drill



Drill Attachments:
Phillips Head



1/8", 3/16", 3/8" &
7/16" Drill Bits



Phillips Screw Driver



Open End Wrench
7/16"



3/8" Drive Ratchet, 1/2" &
7/16" STD Sockets 1/2" & 7/16"
Deep Sockets



Claw Hammer

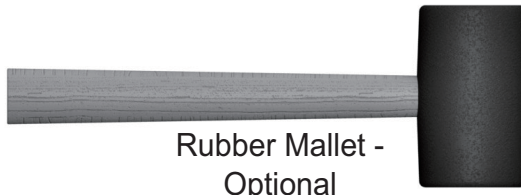

Rubber Mallet -
Optional

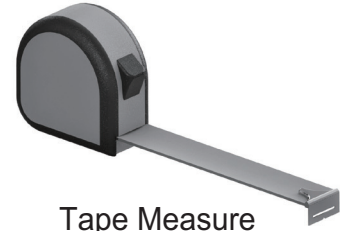

Tape Measure

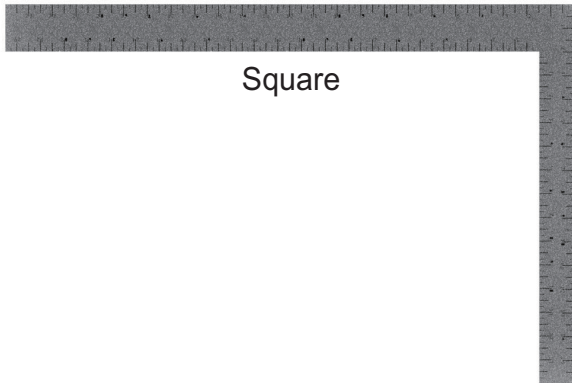

Square



Level 24"

PRE-ASSEMBLY STEP 3 - CHOOSE YOUR ASSEMBLY METHOD

There are several types of assembly instructions available to you.

1. Printed Assembly Manual included with your set
2. BILT APP - 3D interactive instructions
3. Combination of the Printed Manual and BILT APP (Note: Step numbers can differ between the two methods)

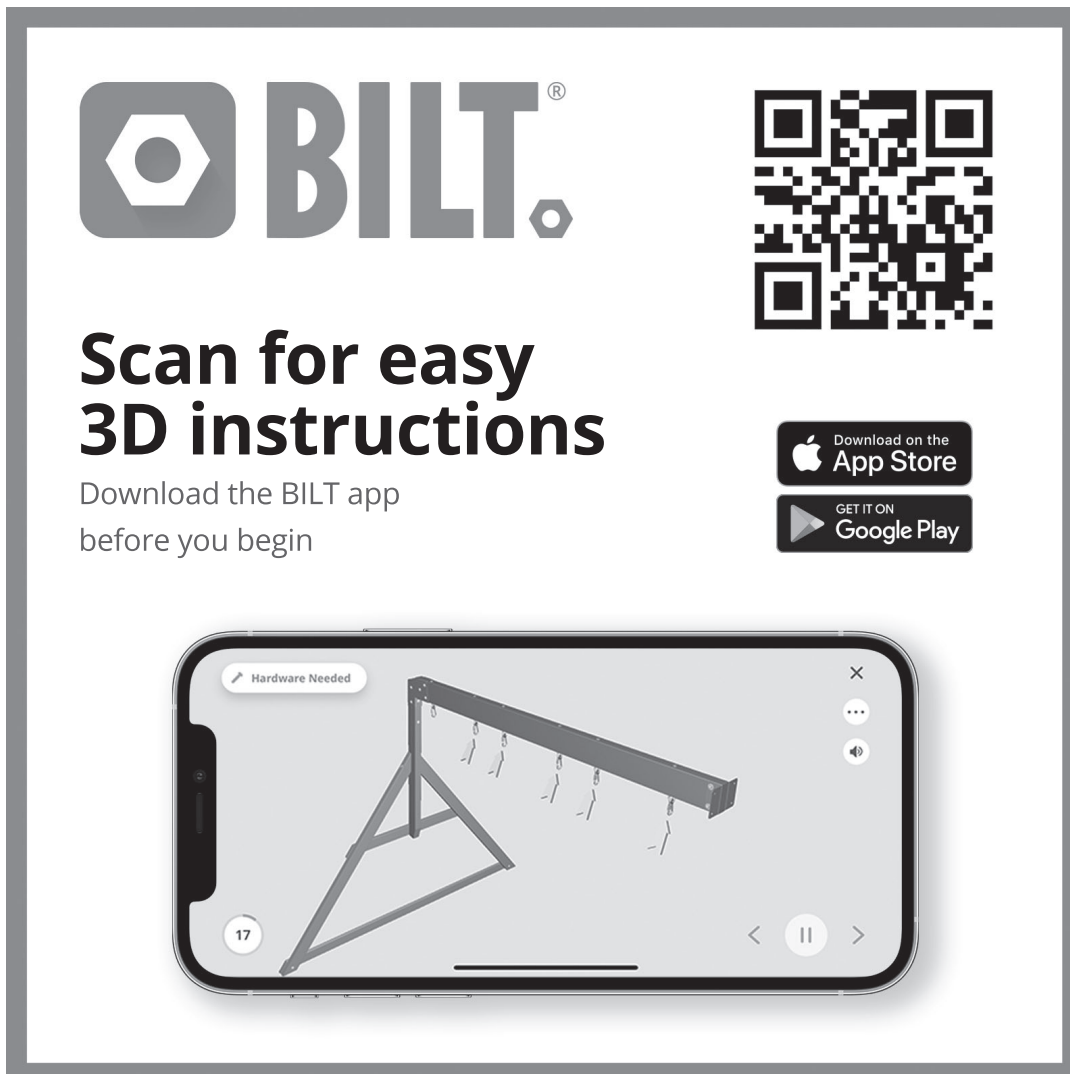

The graphic is a rectangular frame containing the BILT logo (a hexagon with a dot inside) and the word "BILT." with a registered trademark symbol. To the right is a large QR code. Below the logo is the text "Scan for easy 3D instructions" and "Download the BILT app before you begin". To the right of this text are two buttons: "Download on the App Store" and "GET IT ON Google Play". At the bottom is a smartphone displaying a 3D assembly instruction for a metal frame, with a "Hardware Needed" label, a page number "17", and navigation icons.

BILT.[®]

Scan for easy
3D instructions

Download the BILT app
before you begin

Download on the
App Store

GET IT ON
Google Play

Hardware Needed

17

OWNER'S MANUAL - WALL ATTACHMENT TYPES

Determine which wall attachment type works best for your application. If unknown consult a licensed contractor. The recommended hardware below is provided. Backyard Discovery does not assume responsibility for any damages to your house.

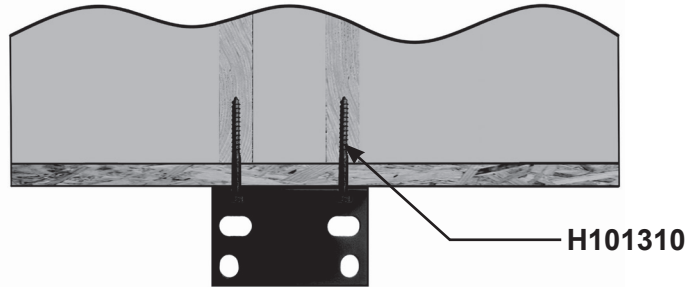

ATTACHING TO WALL WITH LAG SCREWS

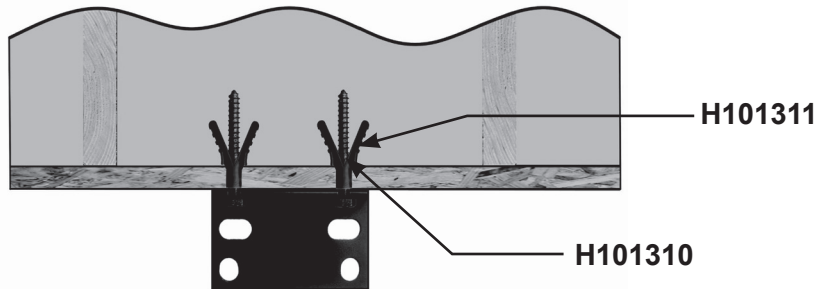

ATTACHING TO WALL WITH LAGS USING PLASTIC ANCHORS

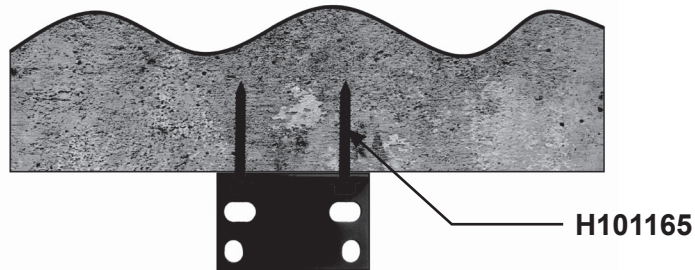

ATTACHING TO MASONRY WITH CONCRETE ANCHORS

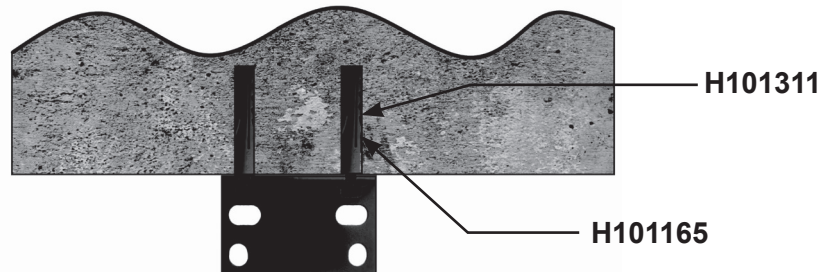

ATTACHING TO MASONRY WITH CONCRETE ANCHORS USING PLASTIC ANCHORS

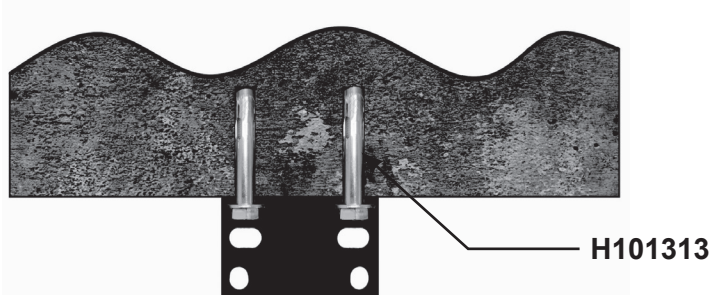

ATTACHING TO MASONRY WITH EXPANSION ANCHORS

STEP 1 - WALL BRACKET LOCATION LAYOUT

1. DRAW A STRAIGHT LINE 8'-0" (2438mm) OFF THE GROUND.

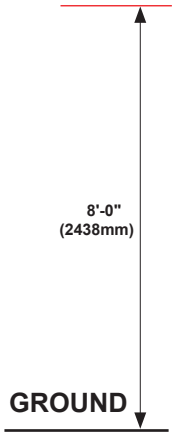

2. ALIGN THE BOTTOM OF T01 WITH THE STRAIGHT LINE AND KEEP IT LEVEL BY USING A 24" LEVEL.

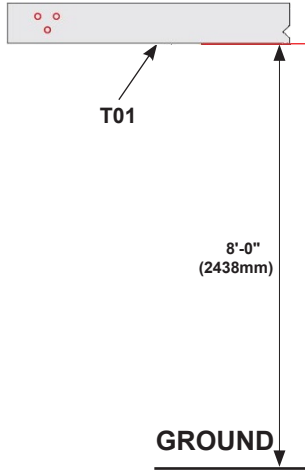

3. DRAW 3 CIRCLES ACCORDING TO HOLES IN T01.

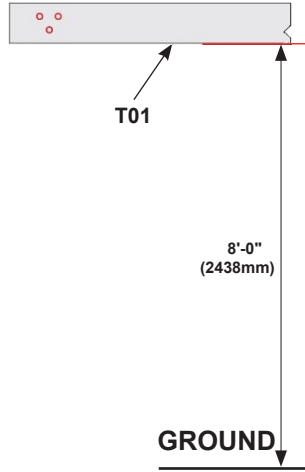

4. ALIGN T02 WITH T01 AND KEEP IT LEVEL BY USING A 24" LEVEL.

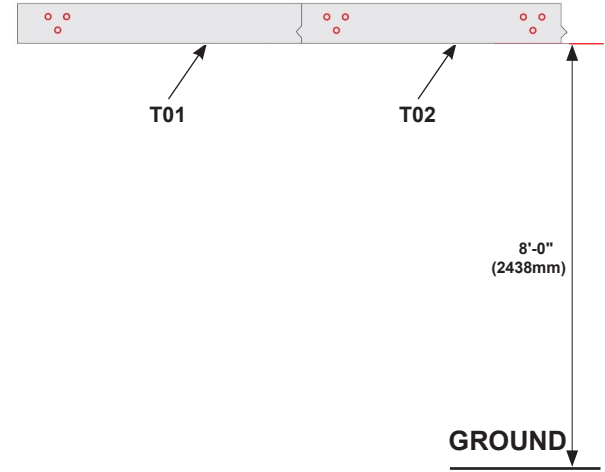

5. DRAW 6 CIRCLES ACCORDING TO HOLES IN T02.

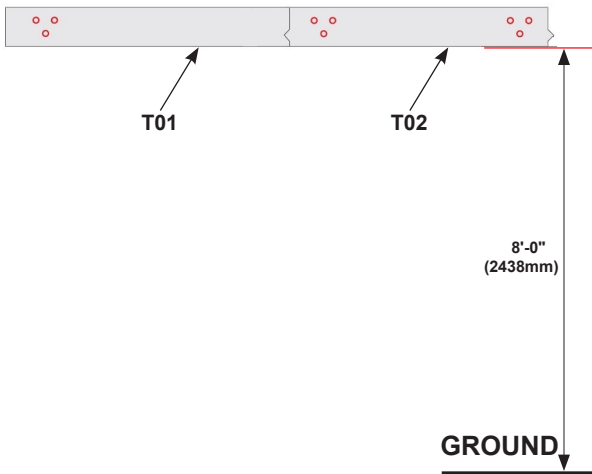

6. ALIGN T01 WITH T02 AND KEEP IT LEVEL BY USING A 24" LEVEL.

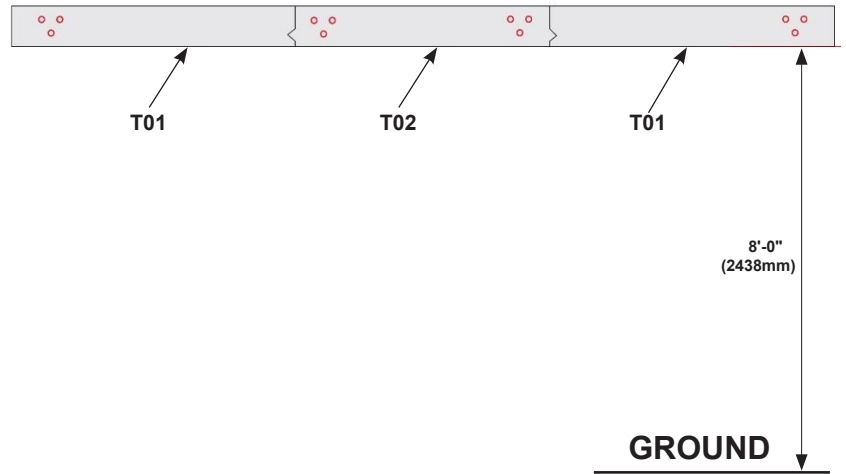

7. DRAW 3 CIRCLES ACCORDING TO HOLES IN T01 .



8. DRILL INTO THE WALL AT THE CENTER OF EACH CIRCLE. DRILL SIZE DETAILS ARE OUTLINE IN STEP 2A-E, DEPENDING ON WHAT ANCHORS YOU ARE USING.

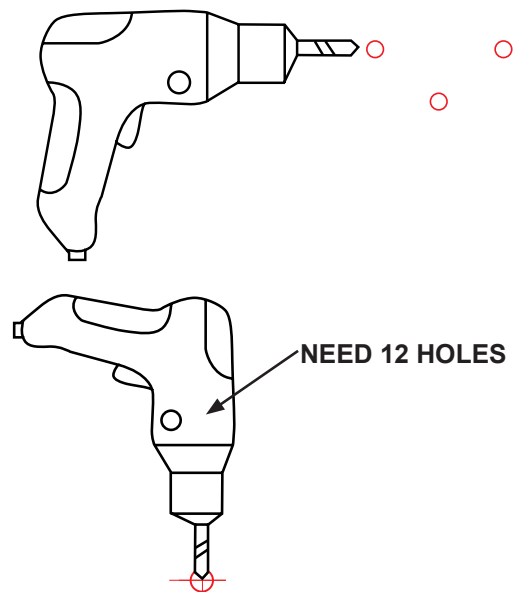

CRITICAL: ALL HOLES MUST BE LEVEL ACROSS THE 4 BRACKETS.

STEP 2A - WALL BRACKET INSTALLATION USING CONCRETE ANCHORS

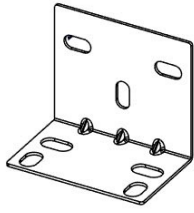

K04 CORNER WALL BRACKET - A4M03483
(x2) 3 15/16"x5 1/8"x6" (99x131x152)

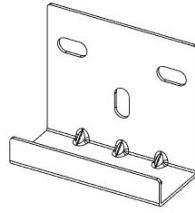

K03 CENTER WALL BRACKET - A4M05899
(x2) 2 11/16"x5 3/16"x6" (69x131x152)

Qty	PartNo	Description
12	H100497	WASHER FLAT 17x30 BLK
12	H101165	CONCRETE ANCHOR 3/8x3" BLK

- DRILL (12) 5/16" [8mm] HOLES IN THE WALL ACCORDING TO LAYOUT IN STEP 1.
- INSTALL WALL BRACKETS WITH CONCRETE ANCHORS.
- THE INSTALLATION HEIGHT OF WALL BRACKETS WILL BE A LITTLE HIGHER THAN THE HEIGHT OF P02 (POST), SO THE TOP HAS A SLIGHT ANGLE TO FACILITATE DRAINAGE.
- REPEAT THIS STEP TWO TIMES

BRACKET LAYOUT

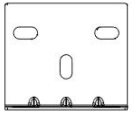

K04

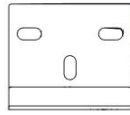

K03

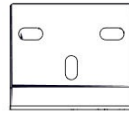

K03

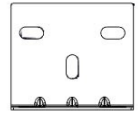

K04

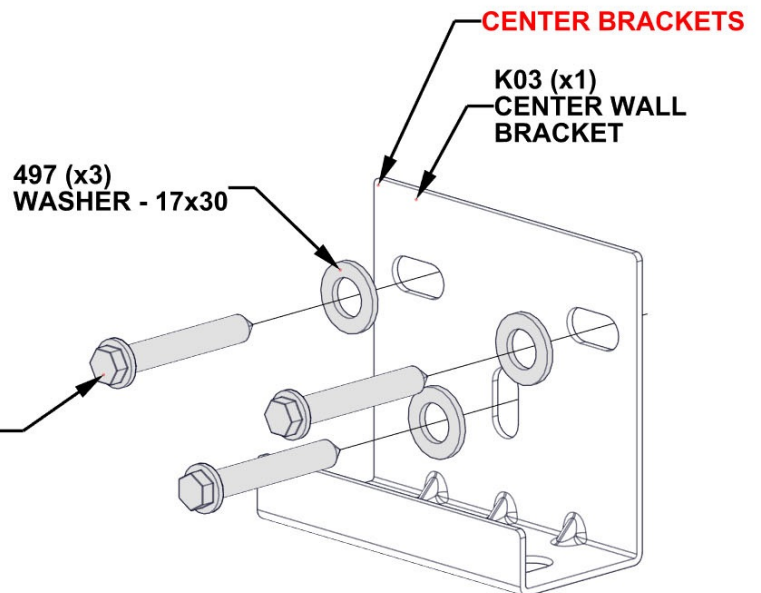
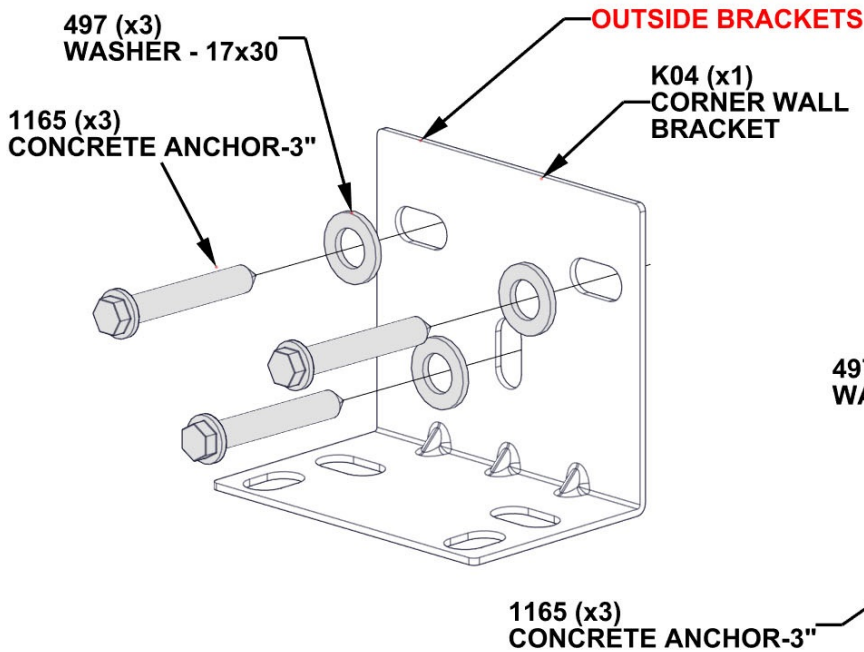

STEP 2B - WALL BRACKET INSTALLATION USING CONCRETE ANCHORS WITH PLASTIC ANCHORS

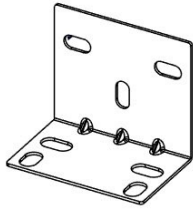

K04 CORNER WALL BRACKET - A4M03483
(x2) 3 15/16"x5 1/8"x6" (99x131x152)

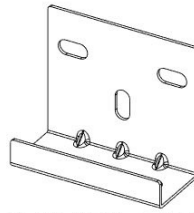

K03 CENTER WALL BRACKET - A4M05899
(x2) 2 11/16"x5 3/16"x6" (69x131x152)

Qty	PartNo	Description
12	H100497	WASHER FLAT 17x30 BLK
12	H101165	CONCRETE ANCHOR 3/8x3" BLK
12	H101311	PLASTIC ANCHOR 3/8x3

- DRILL (12) 1/2" [12mm] HOLES IN THE WALL ACCORDING TO LAYOUT IN STEP 1.
- INSTALL WALL BRACKETS WITH CONCRETE ANCHORS AND PLASTIC ANCHORS.
- THE INSTALLATION HEIGHT OF WALL BRACKETS WILL BE A LITTLE HIGHER THAN THE HEIGHT OF P02 (POST), SO THE TOP HAS A SLIGHT ANGLE TO FACILITATE DRAINAGE.
- REPEAT THIS STEP TWO TIMES

BRACKET LAYOUT

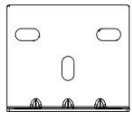

K04

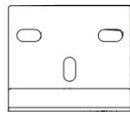

K03

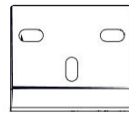

K03

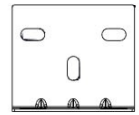

K04

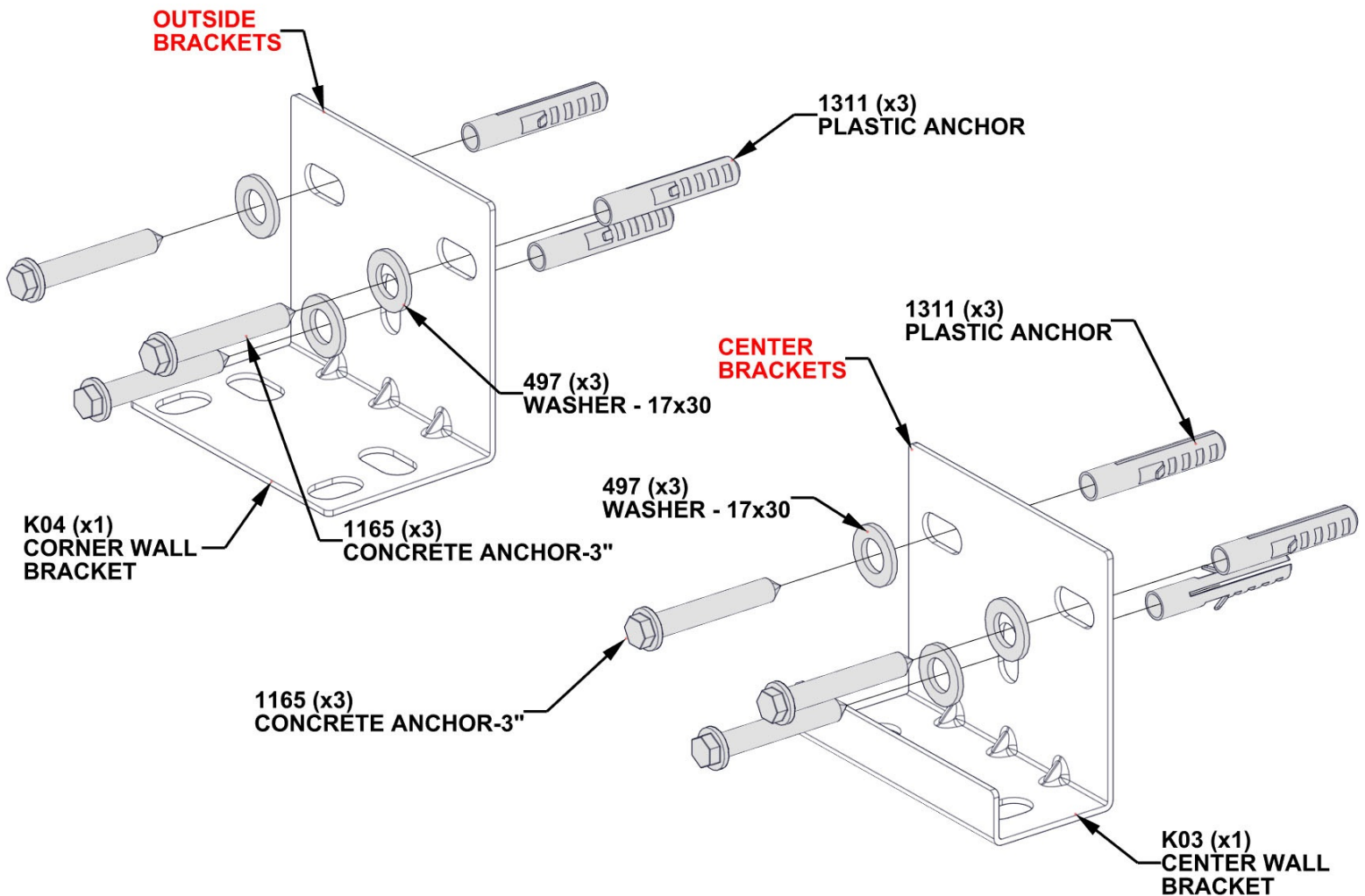

STEP 2C - WALL BRACKET INSTALLATION USING LAG SCREWS

Qty	PartNo	Description
12	H100497	WASHER FLAT 17x30 BLK
12	H101310	LAG BOLT HEX 3/8 X 3 BLK

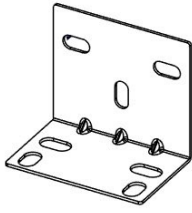

K04 CORNER WALL BRACKET - A4M03483
(x2) 3 15/16"x5 1/8"x6" (99x131x152)

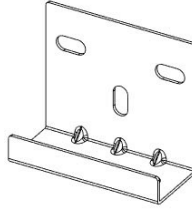

K03 CENTER WALL BRACKET - A4M05899
(x2) 2 11/16"x5 3/16"x6" (69x131x152)

- DRILL (12) 1/4" [7mm] HOLES IN THE WALL ACCORDING TO LAYOUT IN STEP 1.
- INSTALL WALL BRACKETS WITH LAG SCREWS.
- THE INSTALLATION HEIGHT OF WALL BRACKETS WILL BE A LITTLE HIGHER THAN THE HEIGHT OF P02 (POST), SO THE TOP HAS A SLIGHT ANGLE TO FACILITATE DRAINAGE.
- REPEAT THIS STEP TWO TIMES

BRACKET LAYOUT

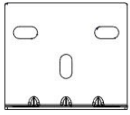

K04

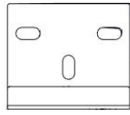

K03

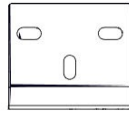

K03

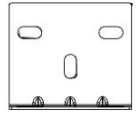

K04

497 (x3)
WASHER - 17x30

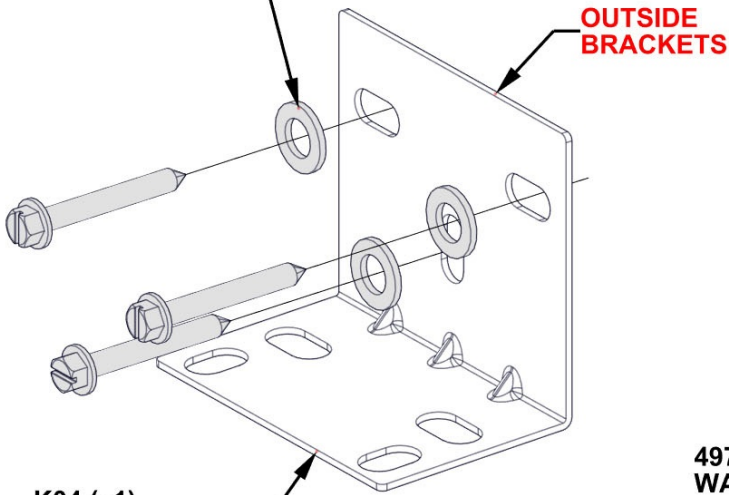

K04 (x1)
CORNER WALL
BRACKET

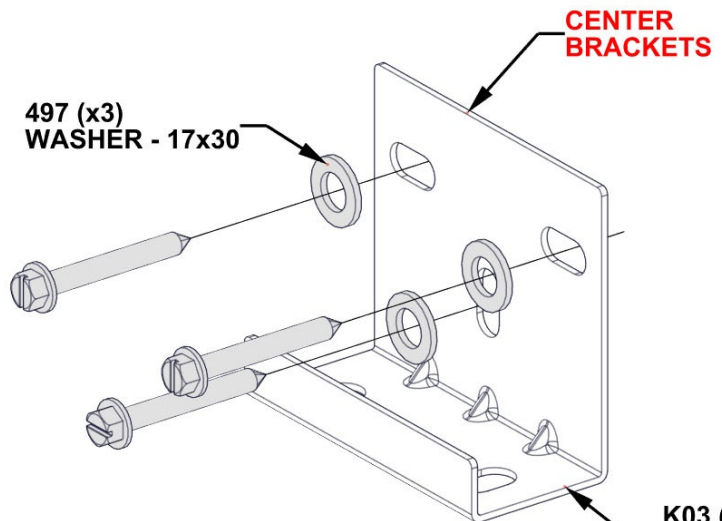

497 (x3)
WASHER - 17x30

K03 (x1)
CENTER WALL
BRACKET

STEP 2D - WALL BRACKET INSTALLATION USING LAG SCREWS WITH PLASTIC ANCHORS

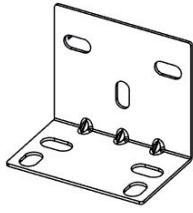

K04 CORNER WALL BRACKET - A4M03483
(x2) 3 15/16"x5 1/8"x6" (99x131x152)

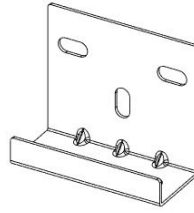

K03 CENTER WALL BRACKET - A4M05899
(x2) 2 11/16"x5 3/16"x6" (69x131x152)

Qty	PartNo	Description
12	H100497	WASHER FLAT 17x30 BLK
12	H101310	LAG BOLT HEX 3/8 X 3 BLK
12	H101311	PLASTIC ANCHOR 3/8x3

- DRILL (12) 1/2" [12mm] HOLES IN THE WALL ACCORDING TO LAYOUT IN STEP 1.
- INSTALL WALL BRACKETS WITH LAG SCREWS AND PLASTIC ANCHORS.
- THE INSTALLATION HEIGHT OF WALL BRACKETS WILL BE A LITTLE HIGHER THAN THE HEIGHT OF P02 (POST), SO THE TOP HAS A SLIGHT ANGLE TO FACILITATE DRAINAGE.
- REPEAT THIS STEP TWO TIMES

BRACKET LAYOUT

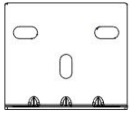

K04

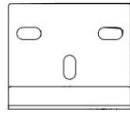

K03

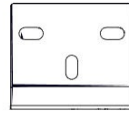

K03

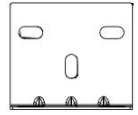

K04

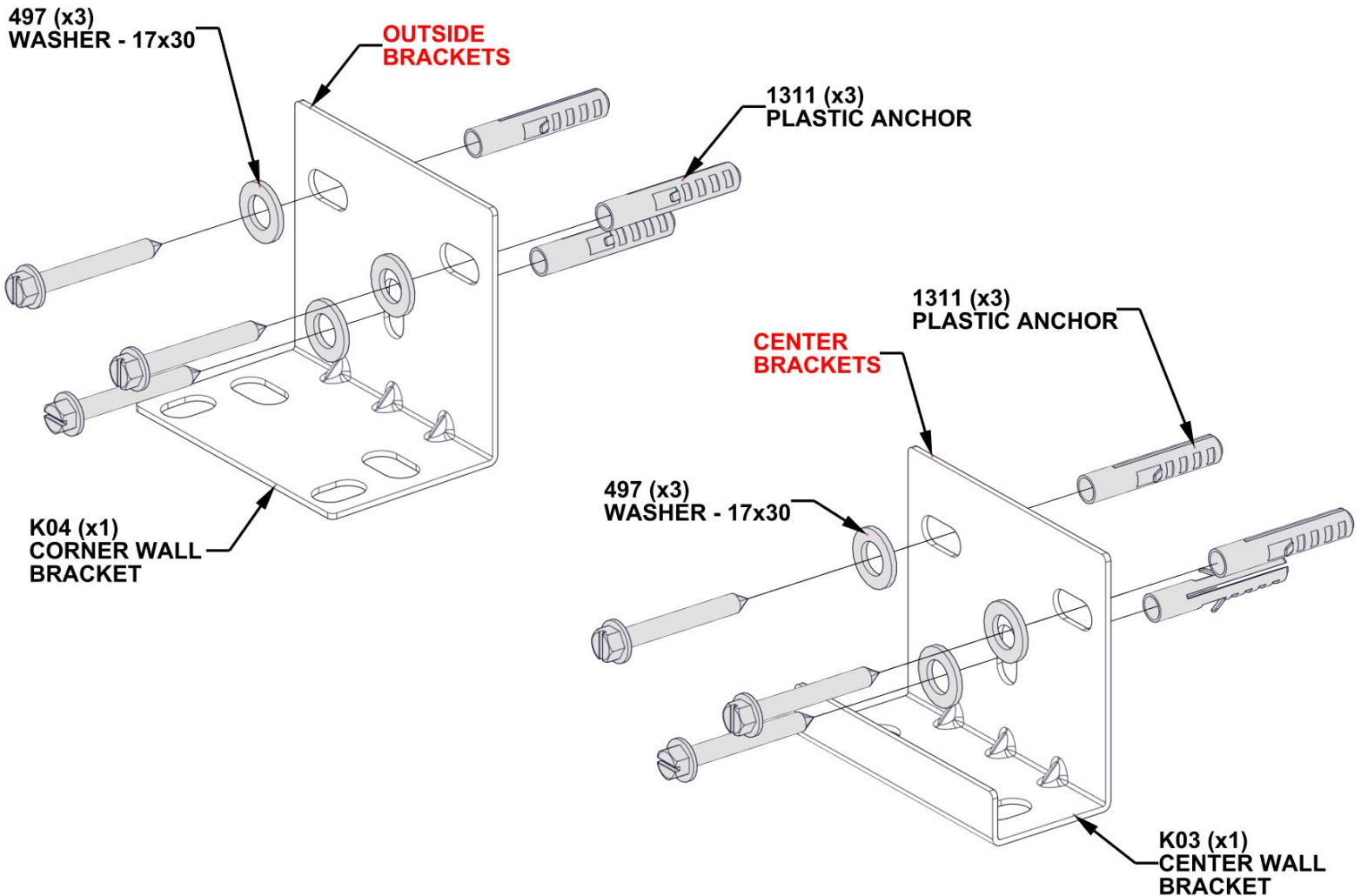

STEP 2E - WALL BRACKET INSTALLATION USING EXPANSION ANCHORS

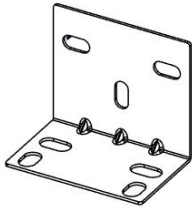

K04 CORNER WALL BRACKET - A4M03483
(2x) 3 15/16"x5 1/8"x6" (99x131x152)

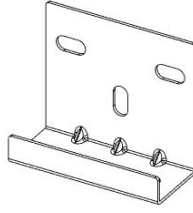

K03 CENTER WALL BRACKET - A4M05899
(2x) 2 11/16"x5 3/16"x6" (69x131x152)

Qty	PartNo	Description
12	H100497	WASHER FLAT 17x30 BLK
12	H101313	EXPANSION ANCHOR

- DRILL (12) 3/8" [10mm] HOLES IN THE WALL ACCORDING TO LAYOUT IN STEP 1.
- INSTALL WALL BRACKETS WITH EXPANSION BOLTS.

- THE INSTALLATION HEIGHT OF WALL BRACKETS WILL BE A LITTLE HIGHER THAN THE HEIGHT OF P02 (POST), SO THE TOP HAS A SLIGHT ANGLE TO FACILITATE DRAINAGE.
- REPEAT THIS STEP TWO TIMES

BRACKET LAYOUT

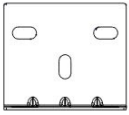

K04

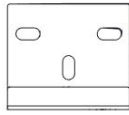

K03

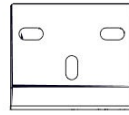

K03

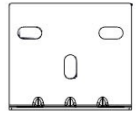

K04

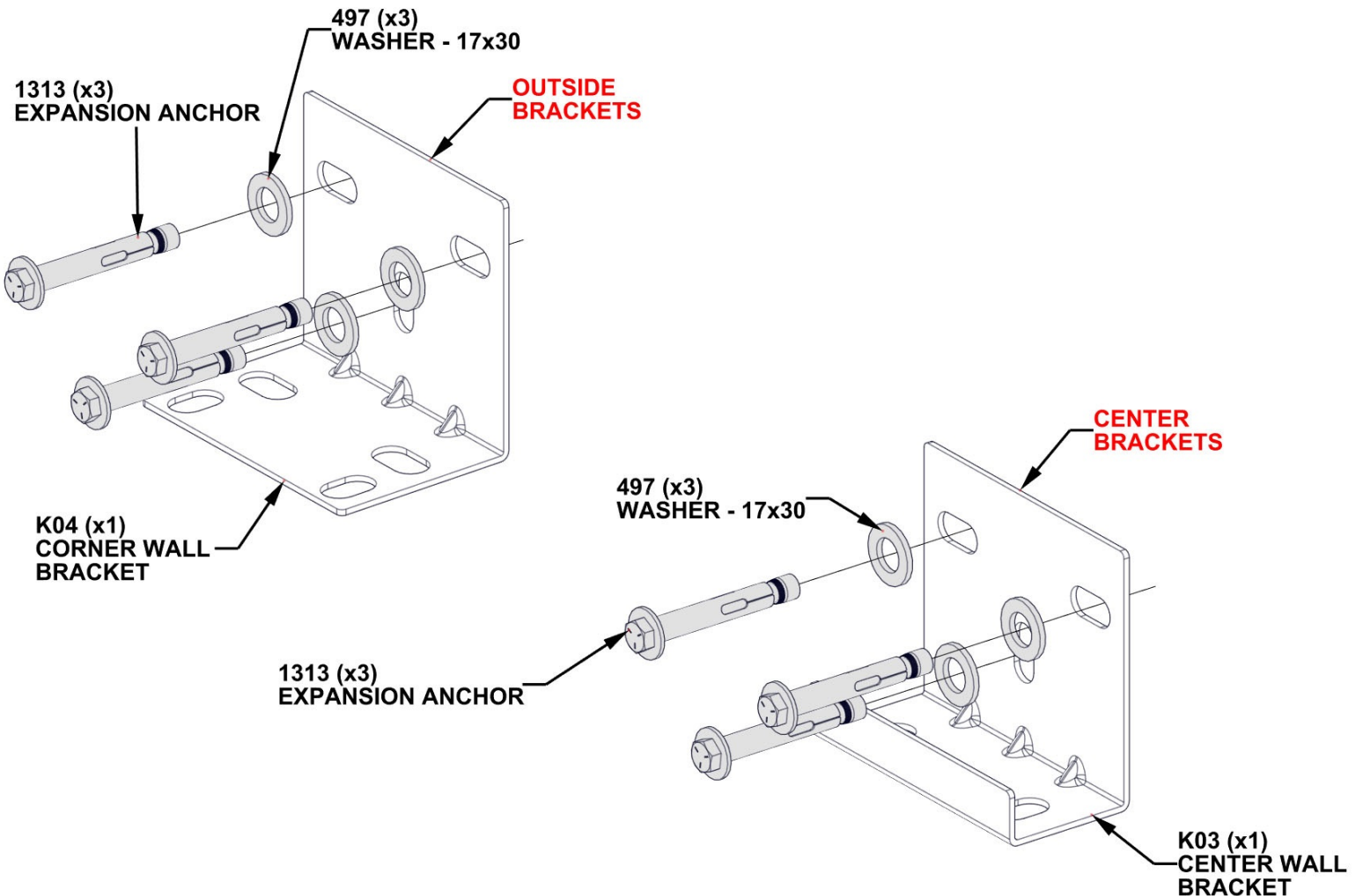

STEP 3A - REAR BEAM ASSEMBLY

Qty	PartNo	Description
3	H101202	TORX PAN HEAD 1/4-20x3/4 ASSY



B03 BEAM - A4M05897
(x1) 1 7/16"x5 1/4"x103 7/8" (36x134x2639)



J1 SPLICE BRACKET - A4M02230
(x1) 1 5/16"x5 3/16"x39 3/8" (33.2x131.2x1000)

- FOR EASE OF ASSEMBLY, WE RECOMMEND USING SAWHORSES FOR STEPS 3A-7
- **HAND TIGHTEN ONLY.**

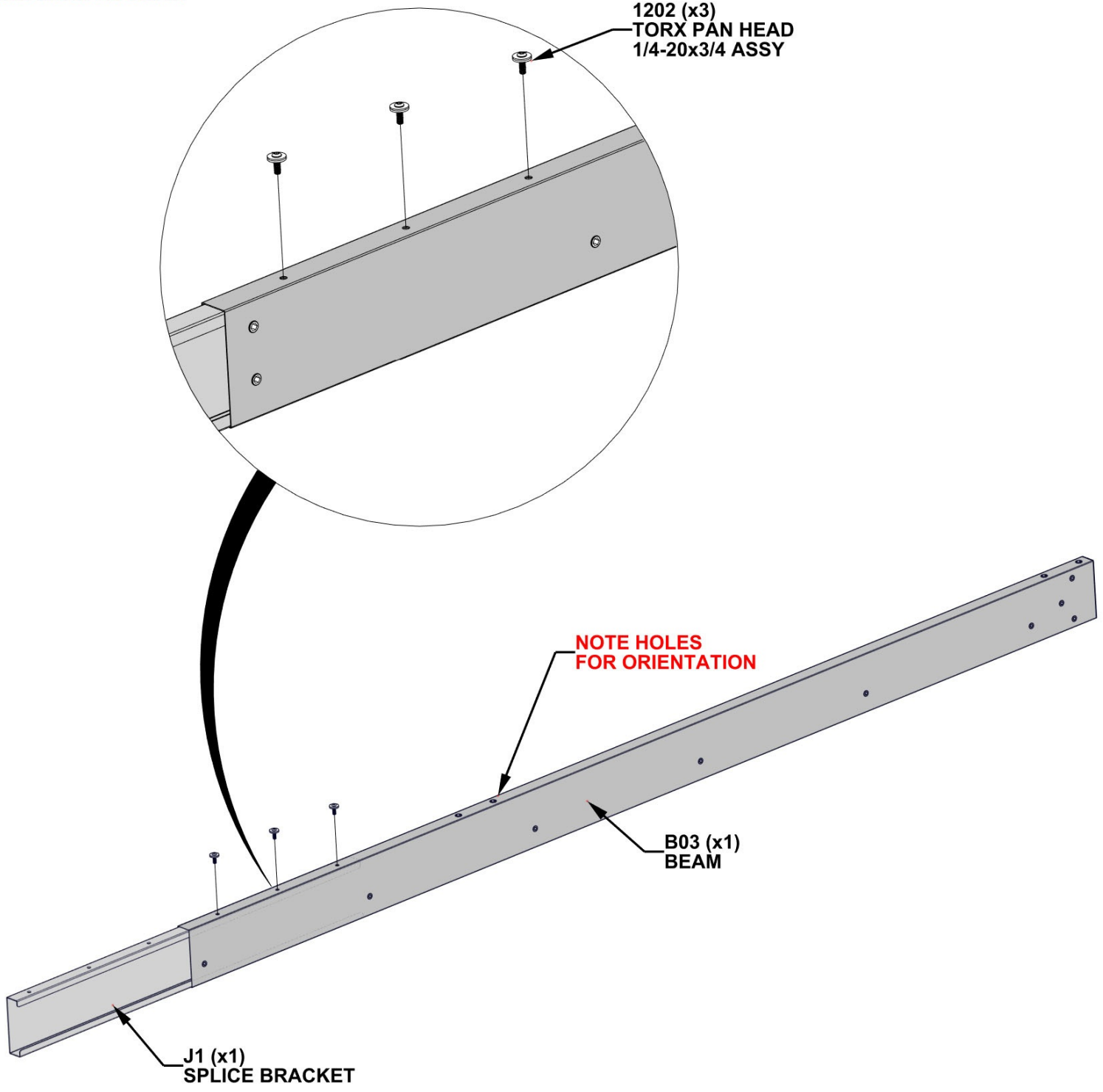

STEP 3B - REAR BEAM ASSEMBLY

Qty	PartNo	Description
3	H101202	TORX PAN HEAD 1/4-20x3/4 ASSY



B05 BEAM - A4M05898
(x1) 1 7/16"x5 1/4"x103 7/8" (36x 134 x2639)

- SLIDE B05 ONTO SPLICE BRACKET. GENTLY TAP ENDS OF ASSEMBLY WITH RUBBER Mallet UNTIL GAP CLOSES, THEN TIGHTEN ALL BOLTS ON BEAM.
- **HAND TIGHTEN ONLY.**

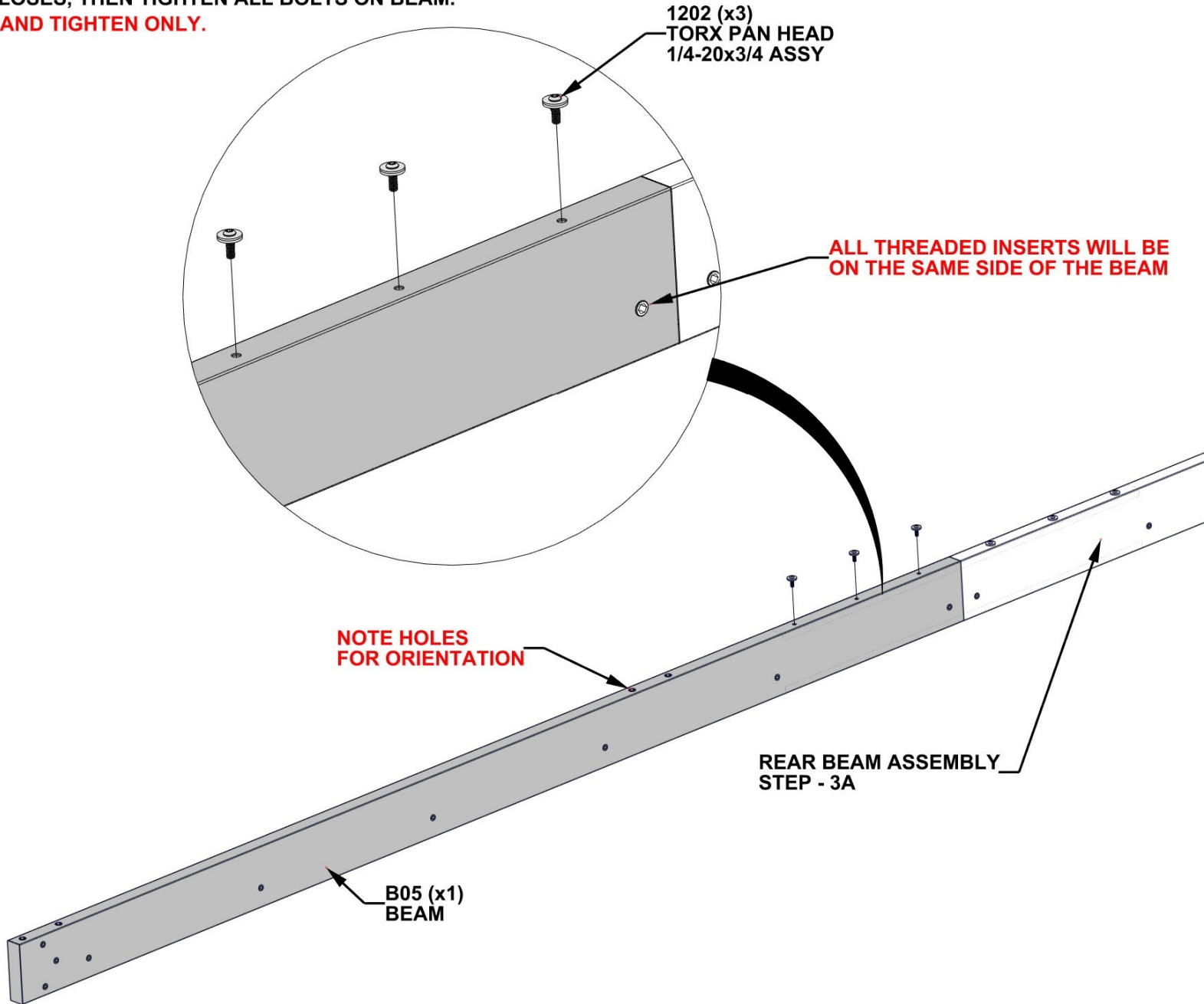

STEP 4A - REAR BEAM ASSEMBLY

Qty	PartNo	Description
6	H101202	TORX PAN HEAD 1/4-20x3/4 ASSY

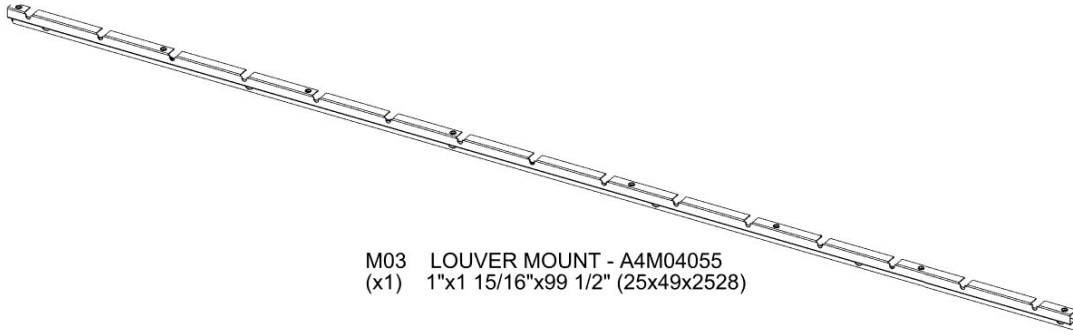

M03 LOUVER MOUNT - A4M04055
(x1) 1"x1 15/16"x99 1/2" (25x49x2528)

- HAND TIGHTEN ONLY.

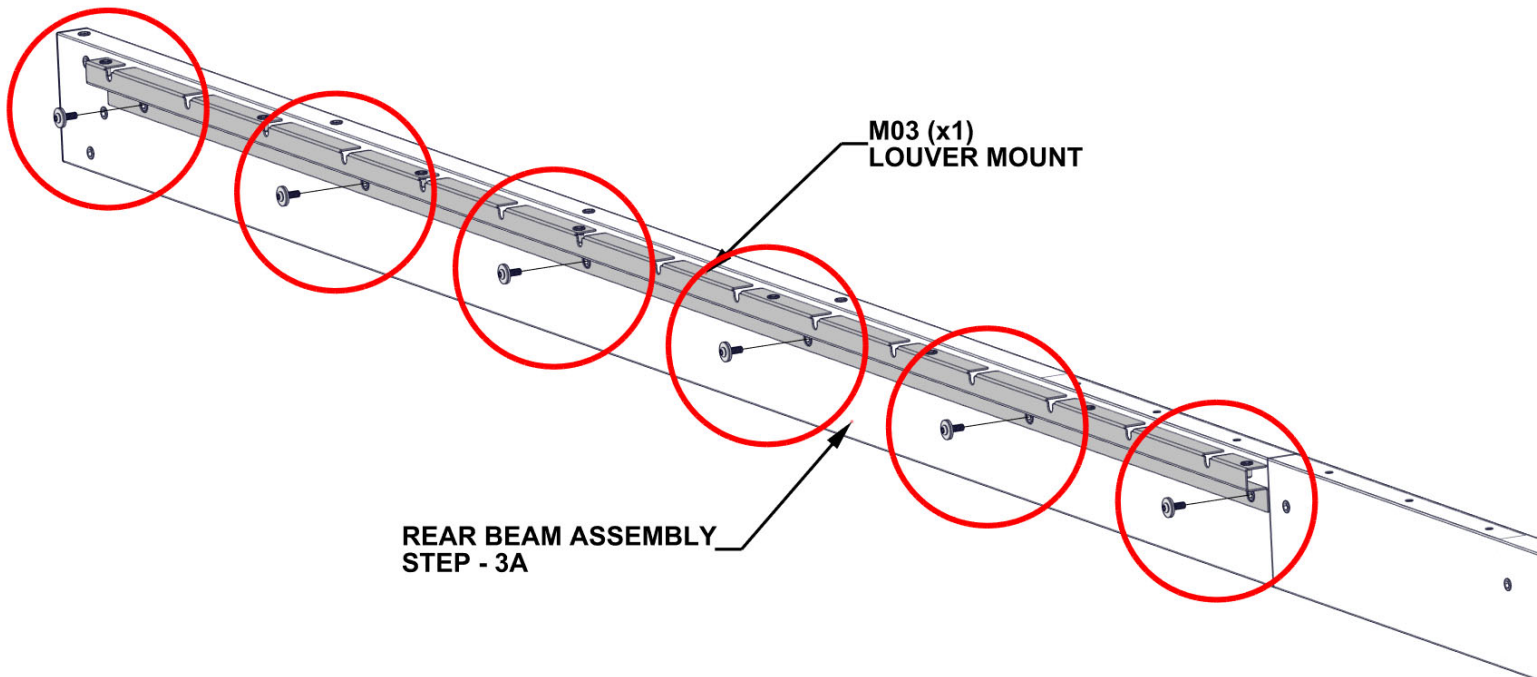
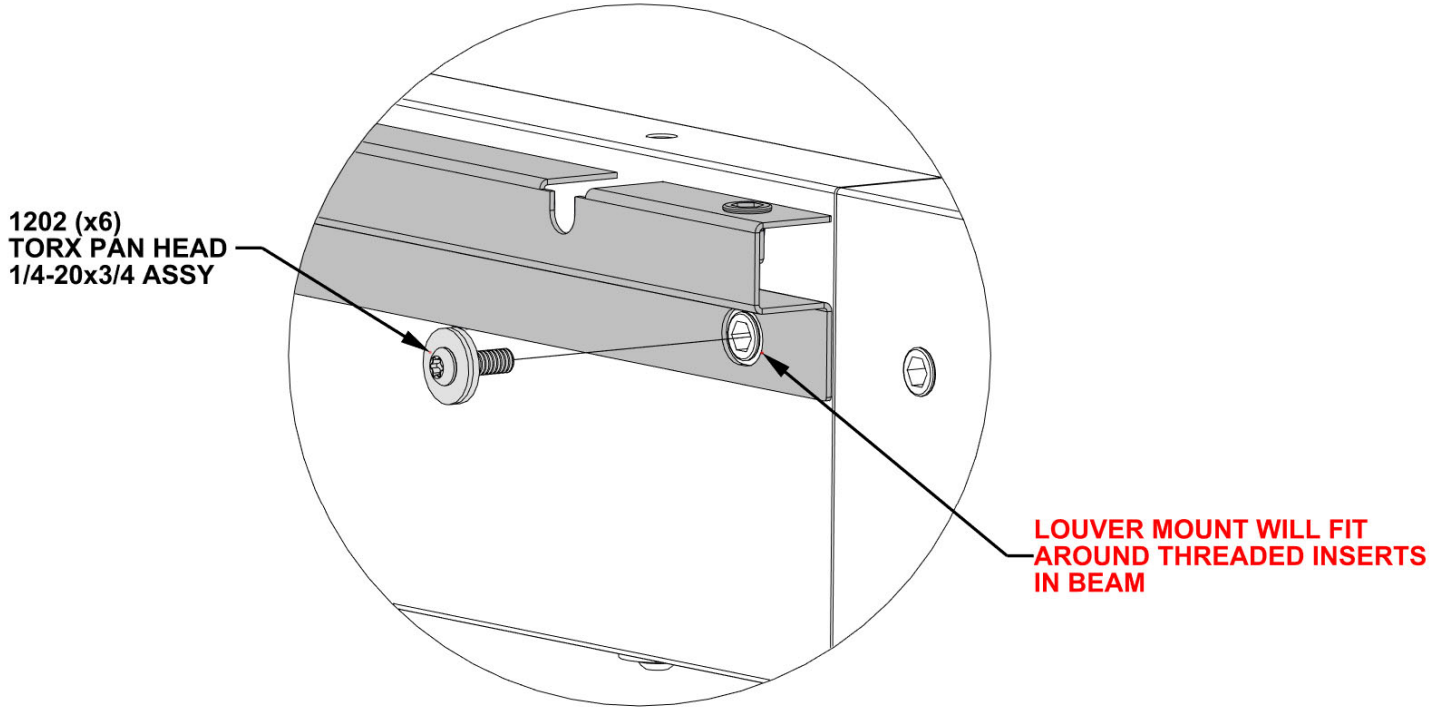

STEP 4B - REAR BEAM ASSEMBLY

Qty	PartNo	Description
6	H101202	TORX PAN HEAD 1/4-20x3/4 ASSY

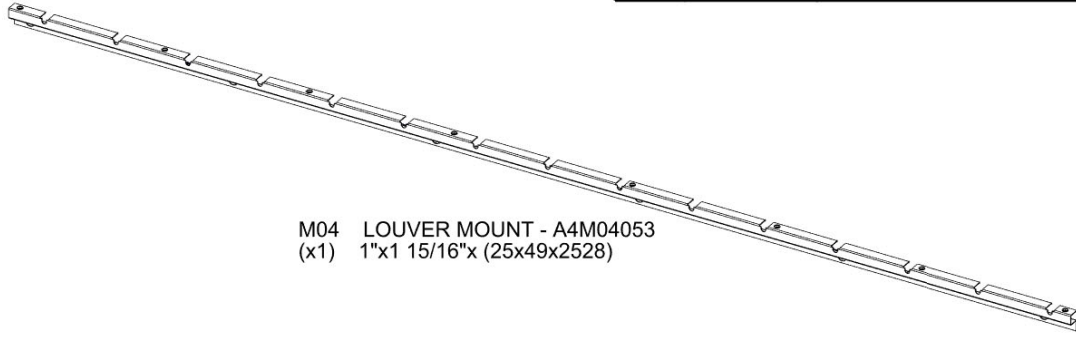

M04 LOUVER MOUNT - A4M04053
(x1) 1"x1 15/16"x (25x49x2528)

- HAND TIGHTEN ONLY.

**SMALL 1/16" [1-2mm] GAP
BETWEEN LOUVER MOUNTS**

**1202 (x6)
TORX PAN HEAD
1/4-20x3/4 ASSY**

**LOUVER MOUNT WILL FIT
AROUND THREADED INSERTS
IN BEAM**

**M04 (x1)
LOUVER MOUNT**

**REAR BEAM ASSEMBLY
STEP - 3B**

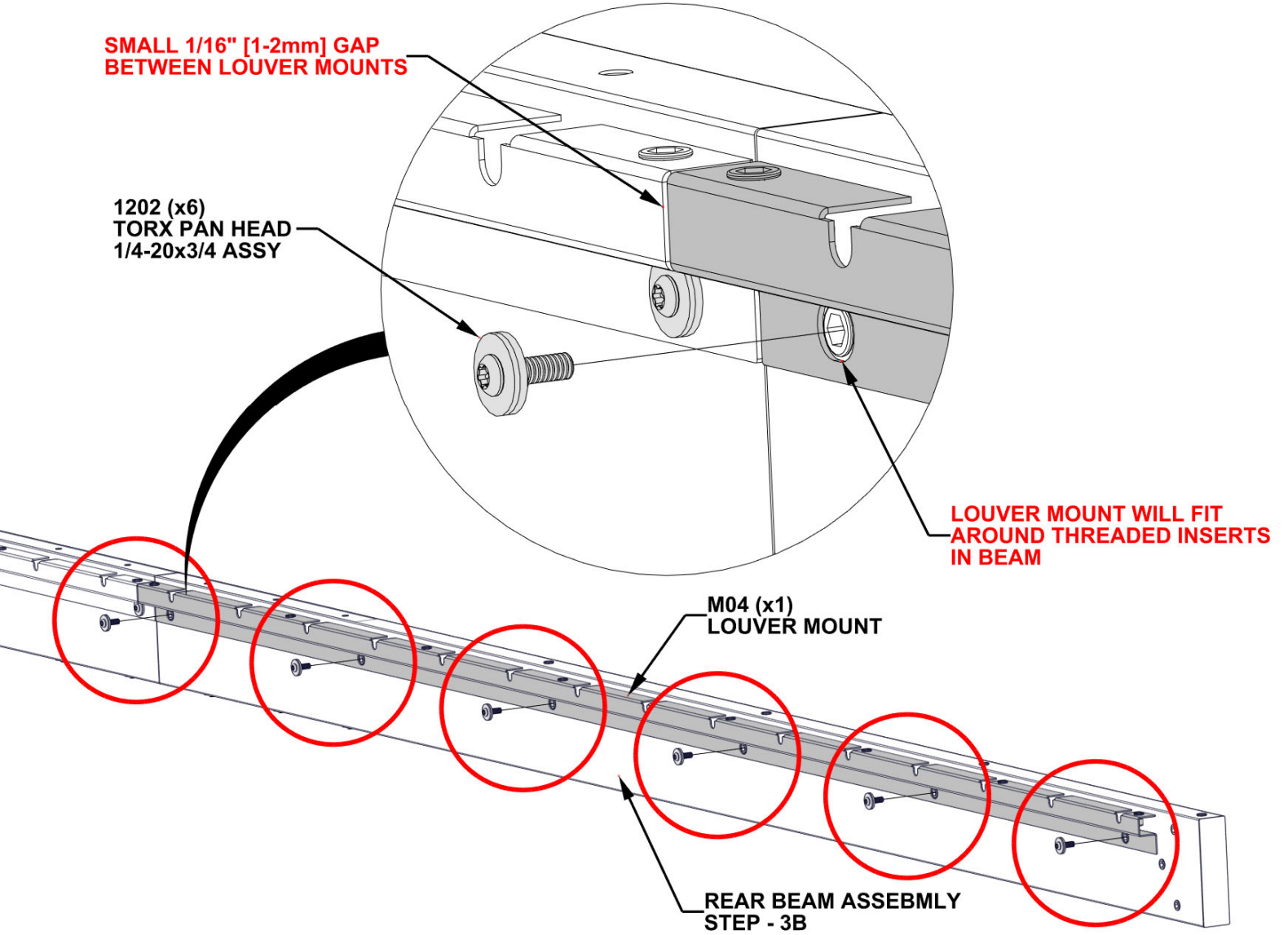

STEP 5 - REAR BEAM WEATHER STRIP

Qty	PartNo	Description
14	H101202	TORX PAN HEAD 1/4-20x3/4 ASSY

K1 WEATHER STRIP - A6P01200
(x1) 1/16"x3 15/16"x199 1/2" (1.6x100x5068)

- ALIGN SCREW HOLES
- WEATHER STRIP WILL NEED TO BE STRETCHED TO ALIGN HOLES. THIS ENSURES A TIGHT SEAL.

1202 (x14)
TORX PAN HEAD
1/4-20x3/4 ASSY

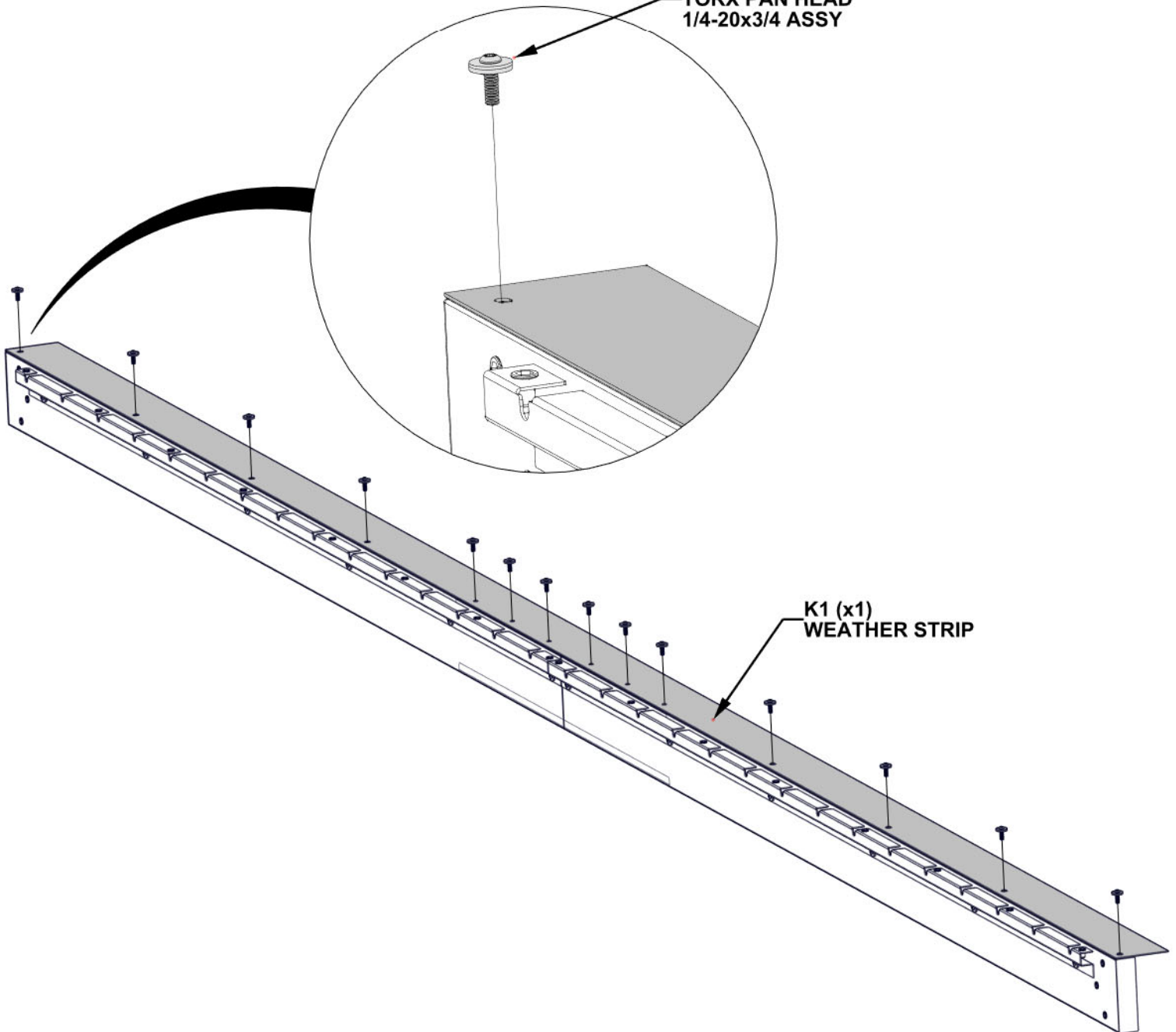

STEP 6 - REAR BEAM POST BRACKET

Qty	PartNo	Description
6	H101202	TORX PAN HEAD 1/4-20x3/4 ASSY

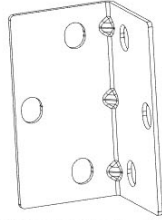

CB01 POST BRACKET - A4M04063
(x2) 2 15/16"x2 15/16"x5 1/4" (74.5x74.5x134)

- HAND TIGHTEN ONLY.

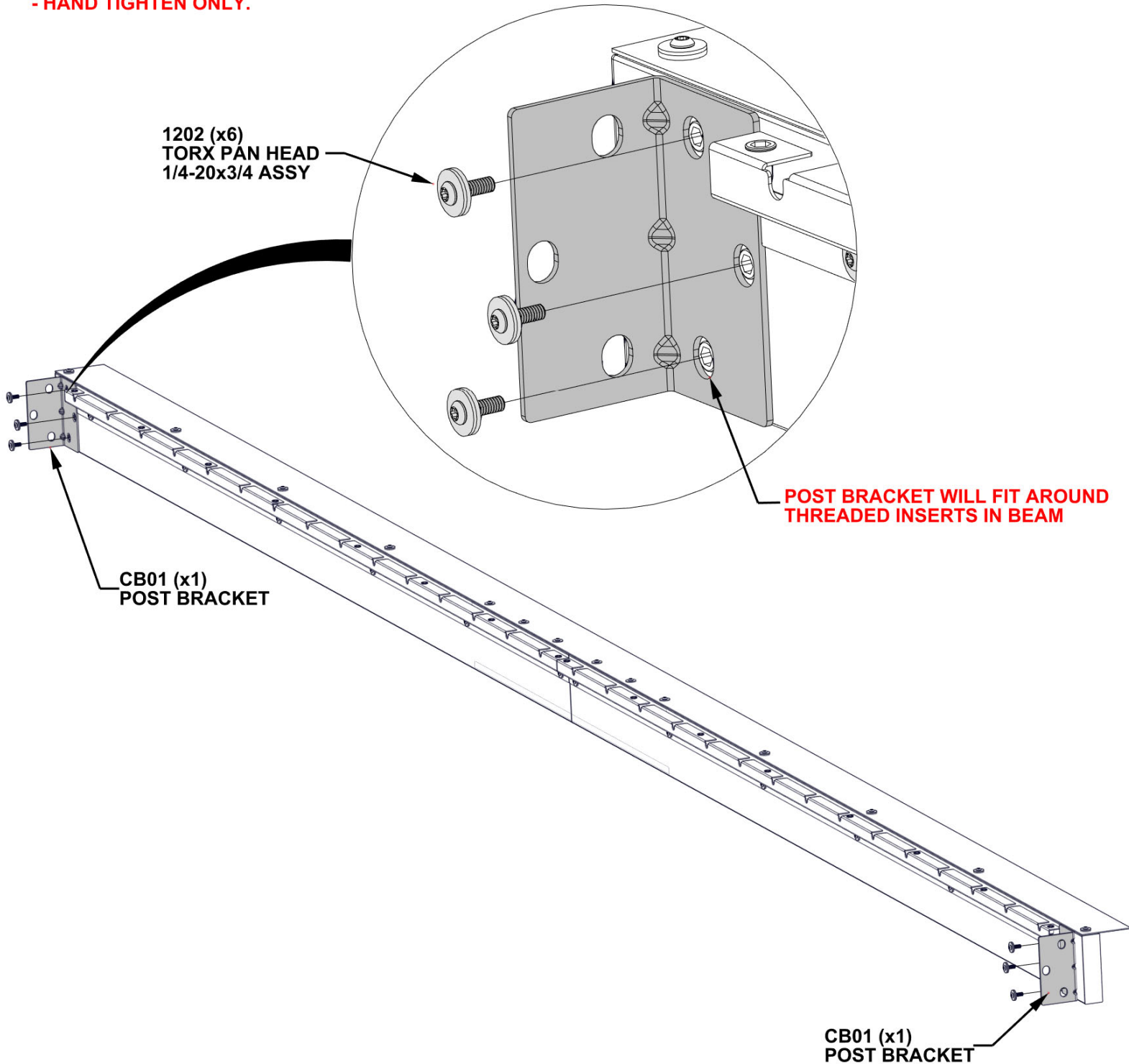

STEP 7 - REAR BEAM ASSEMBLY

Qty	PartNo	Description
8	H100477	WASHER SPLIT 5/16 BLK
8	H100481	BOLT HEX 5/16x1 1/4 BLK
8	H101316	WASHER FLAT 8.5x30 BLK

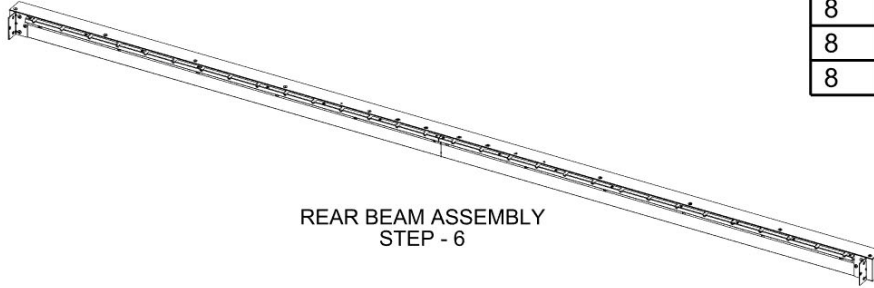

- WITH THE HELP OF ANOTHER ADULT, ATTACH REAR BEAM ASSEMBLY TO WALL BRACKETS.
- ALIGN SCREW HOLES.
- **TIGHTEN ALL HARDWARE FROM PREVIOUS STEPS.**

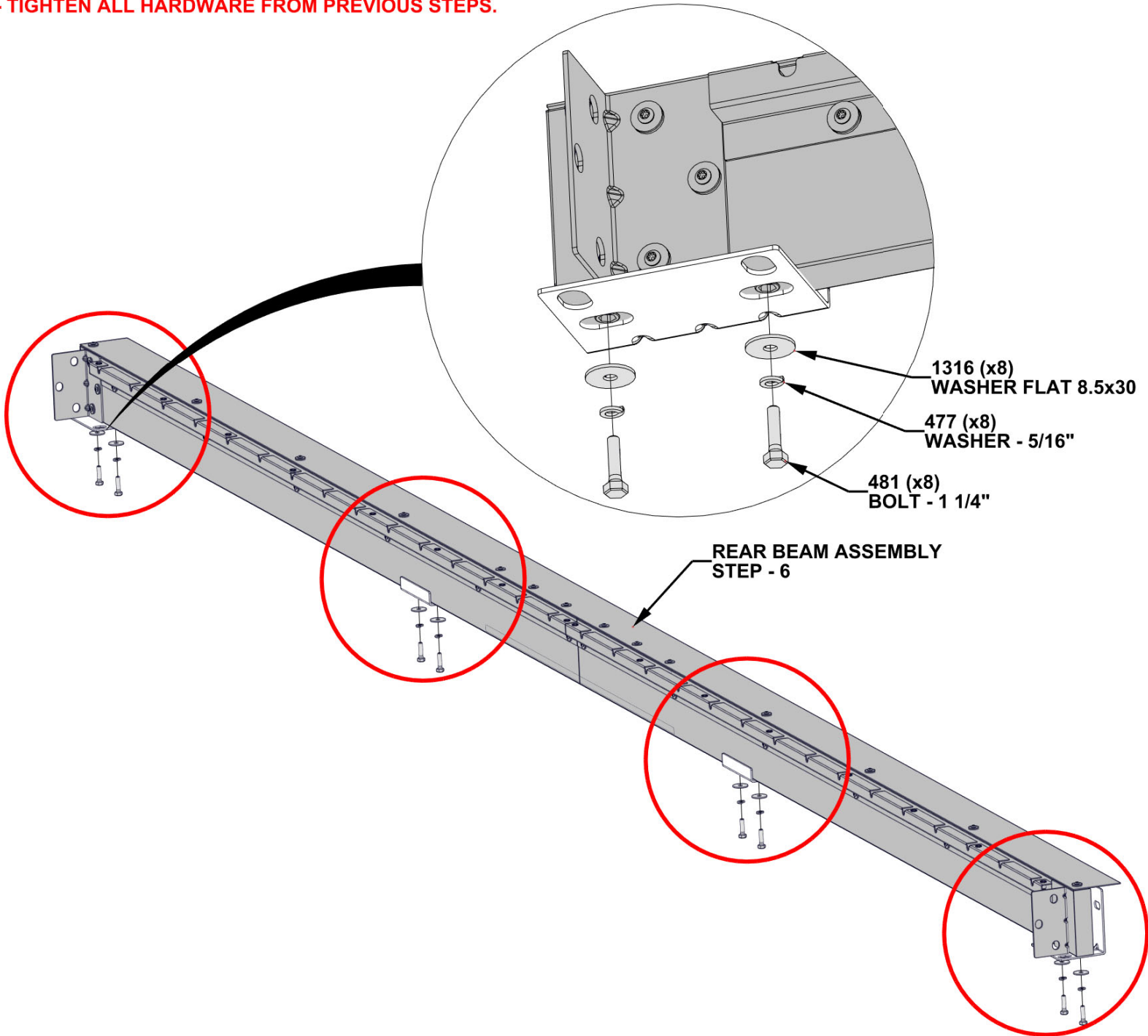

STEP 8A - LEFT FRAME ASSEMBLY

Qty	PartNo	Description
3	H101202	TORX PAN HEAD 1/4-20x3/4 ASSY

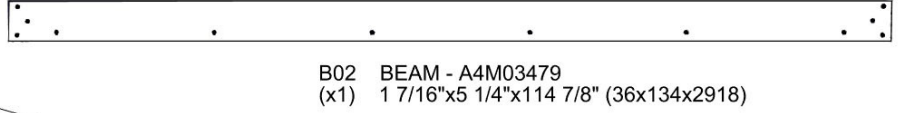
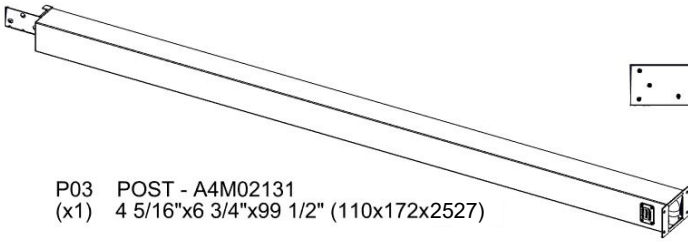

- ATTACH B02 BEAM TO POST BRACKET ON POST P03.
- **HAND TIGHTEN ONLY.**

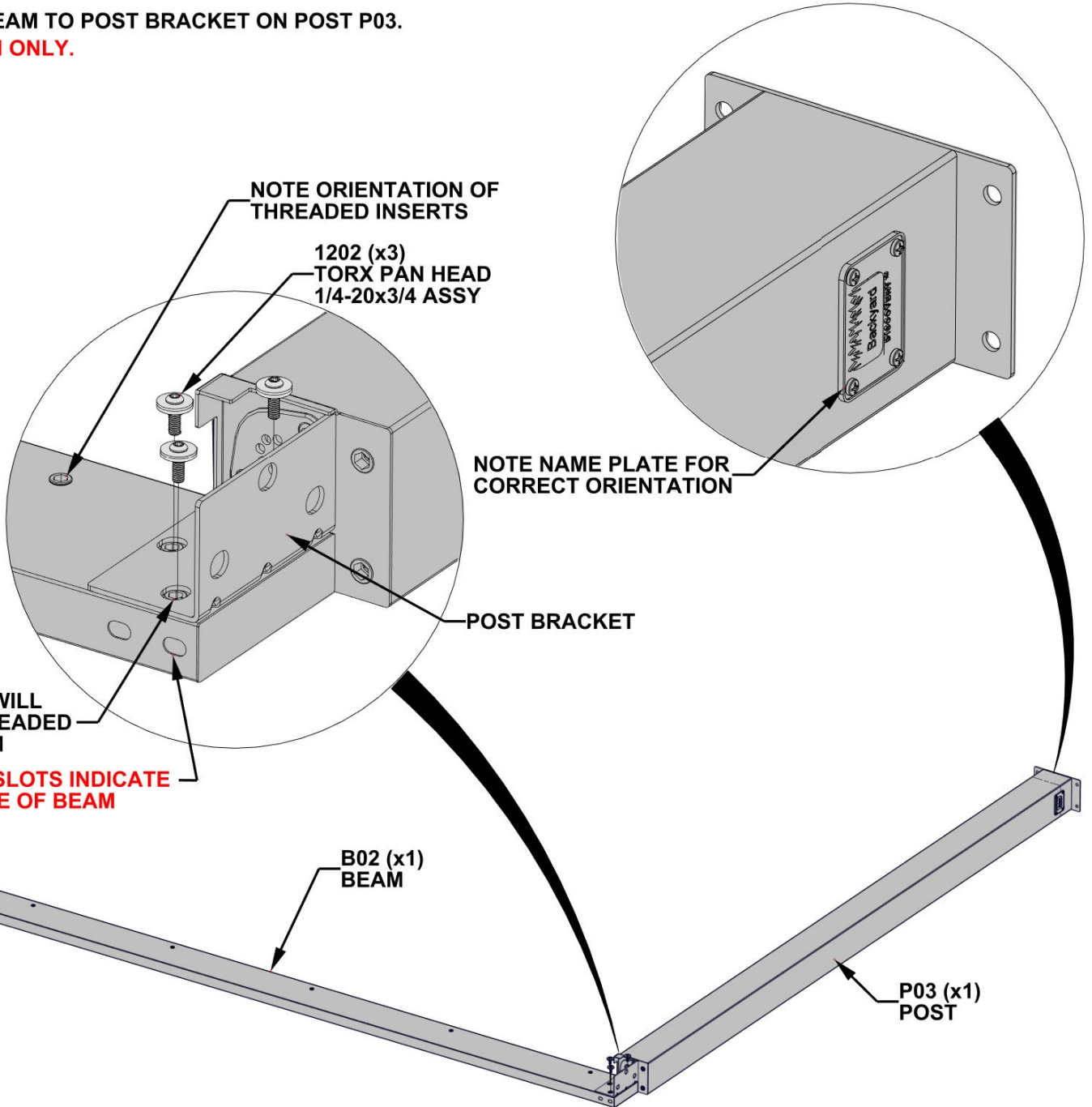

STEP 8B - LEFT FRAME ASSEMBLY

Qty	PartNo	Description
1	H100477	WASHER SPLIT 5/16 BLK
1	H100481	BOLT HEX 5/16x1 1/4 BLK
2	H101230	BOLT WH 5/16x6 S.S.
1	H101316	WASHER FLAT 8.5x30 BLK

- WITH AT LEAST TWO EXTRA PEOPLE, ATTACH B02 BEAM TO P03 POST AND CB01 POST BRACKET ON REAR BEAM.
- ALIGN SLOTS IN BEAM WITH THREADED INSERTS ON TOP PLATE. FLUSH ALL SIDES OF BEAM AND POST.

- HAND TIGHTEN ONLY.

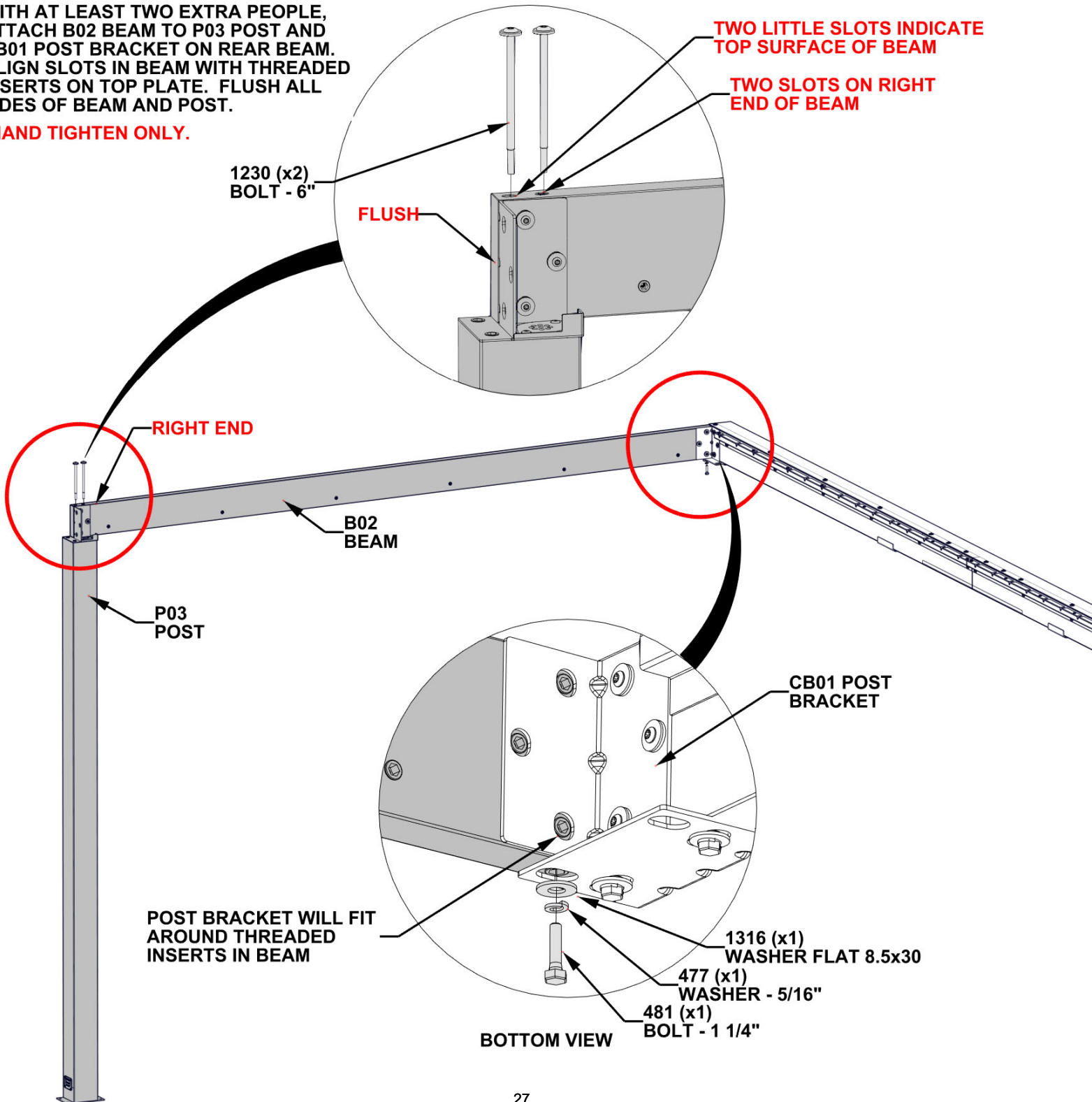

STEP 8C - LEFT FRAME ASSEMBLY

Qty	PartNo	Description
3	H101202	TORX PAN HEAD 1/4-20x3/4 ASSY

- HAND TIGHTEN ONLY.

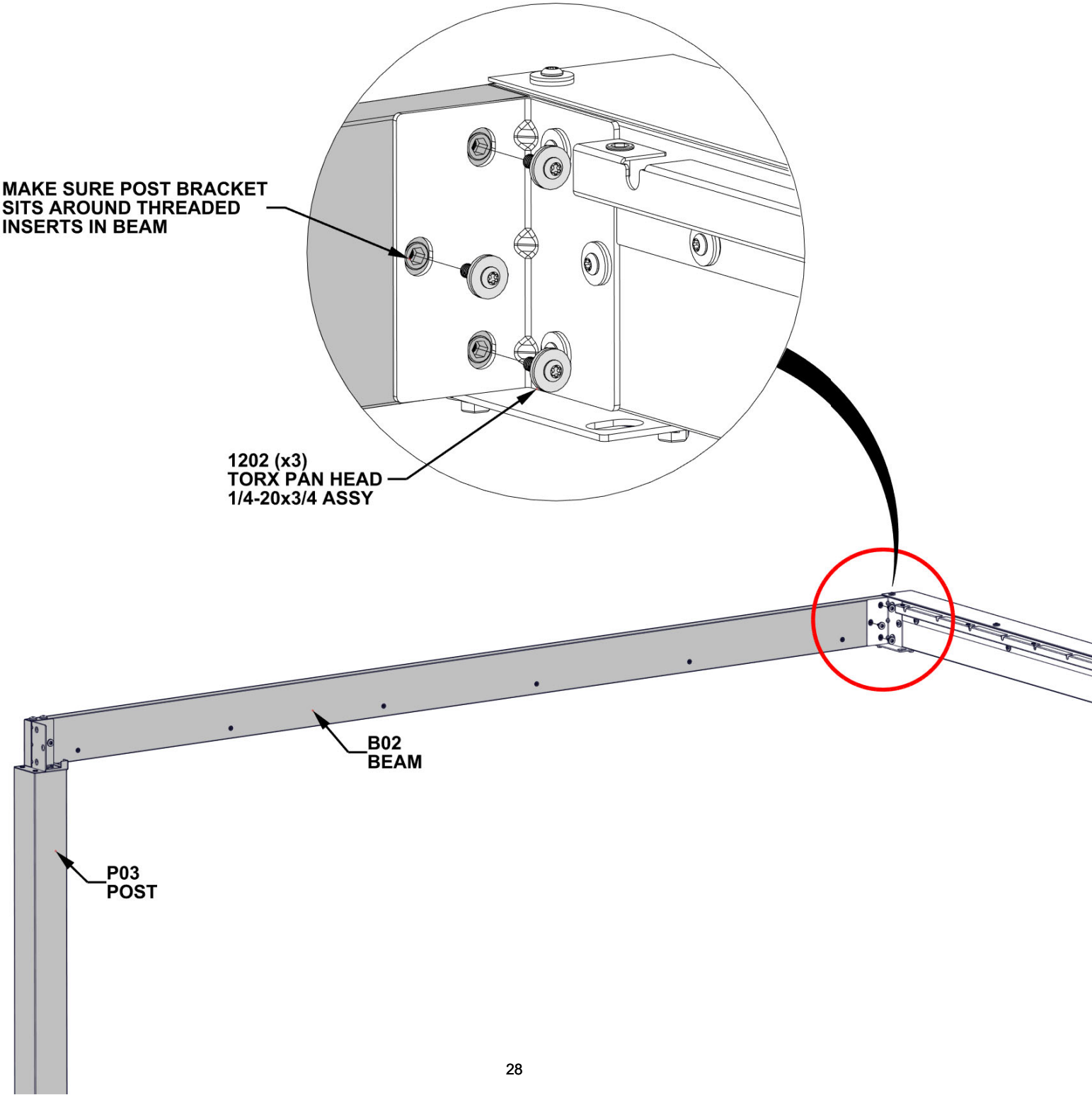

STEP 9 - LEFT GUTTER ASSEMBLY

QTY	PART NUMBER	DESCRIPTION
6	H101202	TORX PAN HEAD 1/4-20x3/4 ASSY

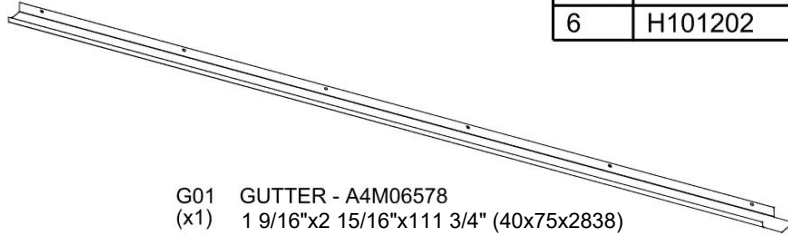

G01 GUTTER - A4M06578
 (x1) 1 9/16"x2 15/16"x111 3/4" (40x75x2838)

- WITH AN ADDITIONAL PERSON, ATTACH GUTTER TO BEAM.
- MAKE SURE ENDS OF GUTTER SIT ON TOP SURFACE OF EACH POST BRACKET.
- TIGHTEN ALL HARDWARE FROM PREVIOUS STEPS.

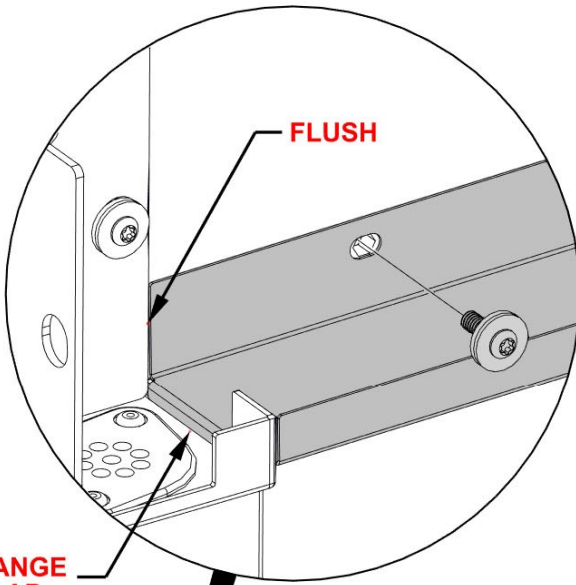

GUTTER FLANGE
 WILL OVERLAP
 EDGE OF POST

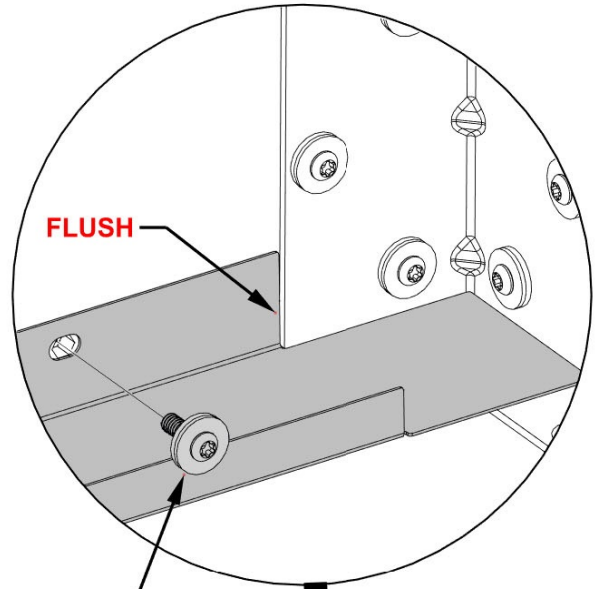

1202 (x6)
 TORX PAN HEAD
 1/4-20x3/4 ASSY

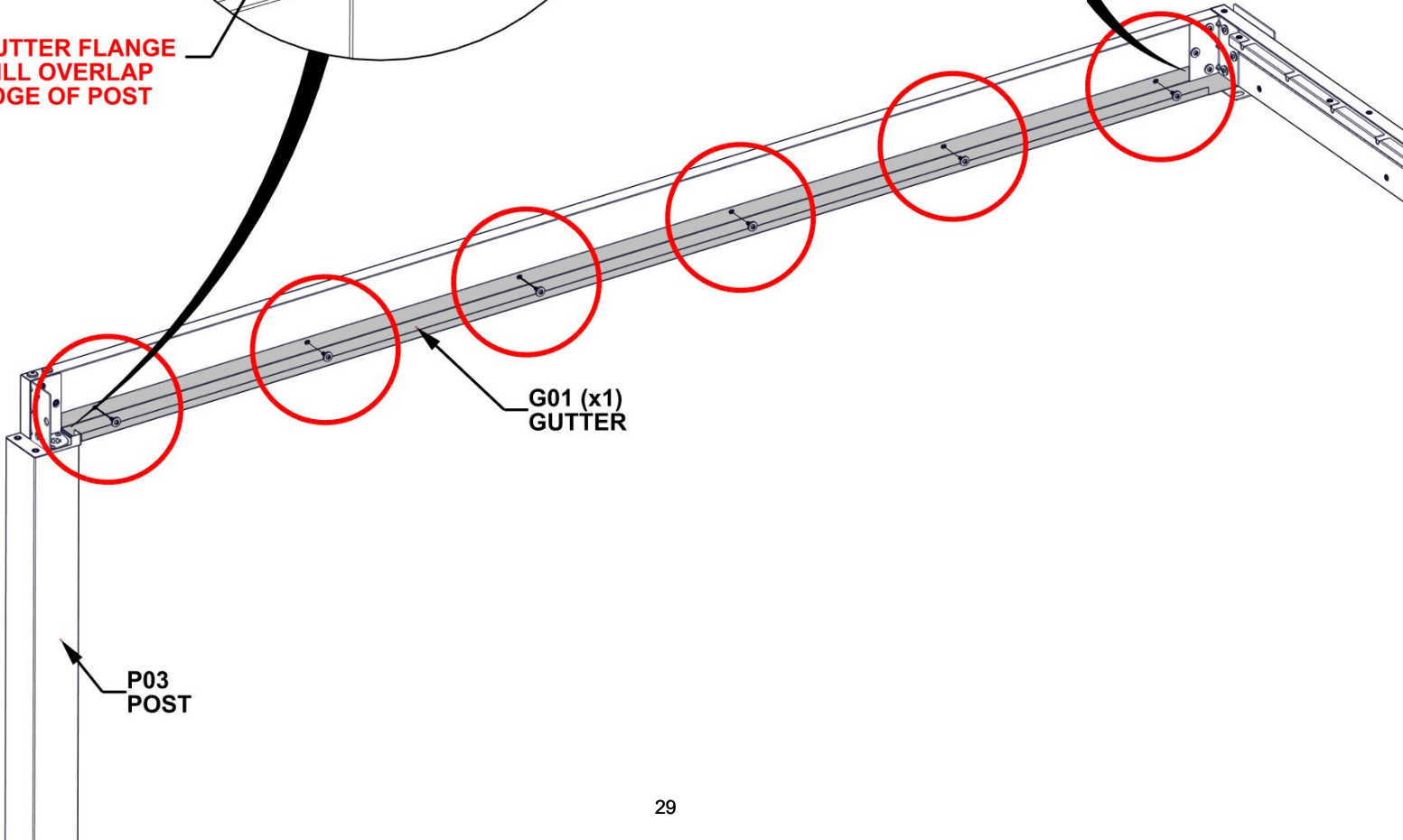

STEP 10A - RIGHT FRAME ASSEMBLY

Qty	PartNo	Description
3	H101202	TORX PAN HEAD 1/4-20x3/4 ASSY



B01 BEAM - A4M03480
(x1) 1 7/16"x5 1/4"x114 7/8" (36x134x2918)



P02 POST - A4M01984
(x1) 4 5/16"x6 3/4"x99 1/2" (110x172x2527)

- ATTACH B01 TO POST BRACKET ON POST P02.
- **HAND TIGHTEN ONLY.**

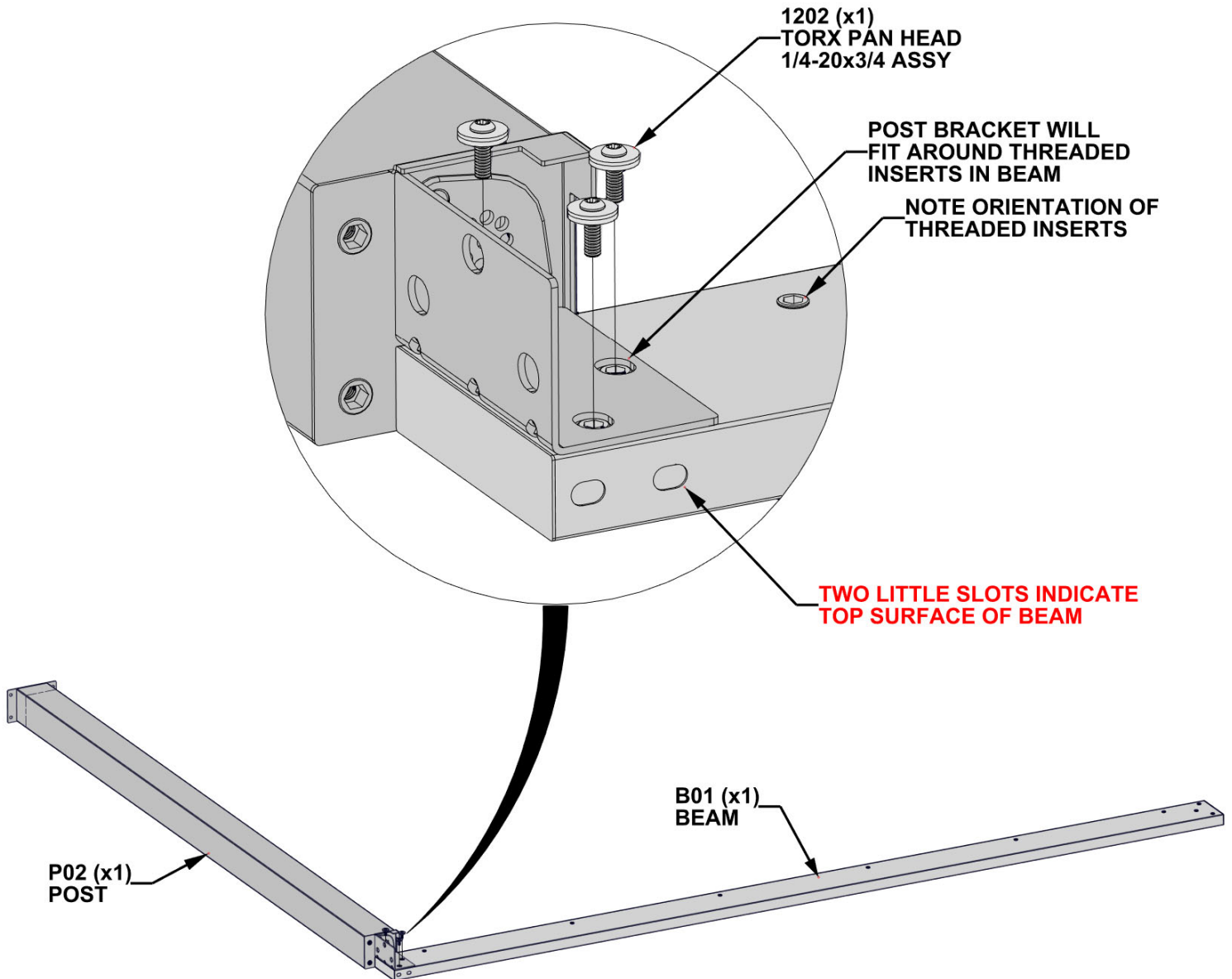

STEP 10B - RIGHT FRAME ASSEMBLY

Qty	PartNo	Description
1	H100477	WASHER SPLIT 5/16 BLK
1	H100481	BOLT HEX 5/16x1 1/4 BLK
2	H101230	BOLT WH 5/16x6 S.S.
1	H101316	WASHER FLAT 8.5x30 BLK

- WITH AT LEAST TWO EXTRA PEOPLE, ATTACH B01 BEAM TO P02 AND CB01 POST BRACKET ON REAR BEAM.
- ALIGN SLOTS IN BEAM WITH THREADED INSERTS ON TOP PLATE. FLUSH ALL SIDES OF BEAM AND POST.

- HAND TIGHTEN ONLY.

CB01
POST BRACKET

BRACKET WILL FIT
AROUND THREADED
INSERTS IN BEAM

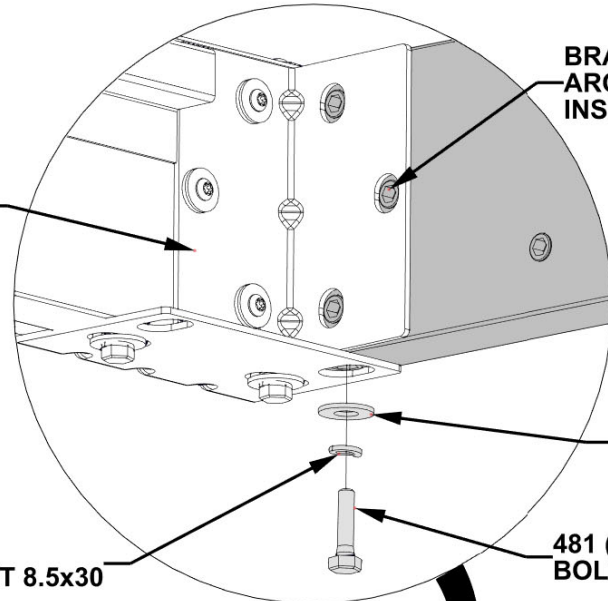

477 (x1)
WASHER - 5/16"

1316 (x1)
WASHER FLAT 8.5x30

481 (x1)
BOLT - 1 1/4"

BOTTOM VIEW

LEFT END

B01
BEAM

P02
POST

1230 (x2)
BOLT - 6"

TWO SLOTS ON LEFT
END OF BEAM

FLUSH

TWO LITTLE SLOTS INDICATE
TOP SURFACE OF BEAM

STEP 10C - RIGHT FRAME ASSEMBLY

Qty	PartNo	Description
3	H101202	TORX PAN HEAD 1/4-20x3/4 ASSY

- HAND TIGHTEN ONLY.

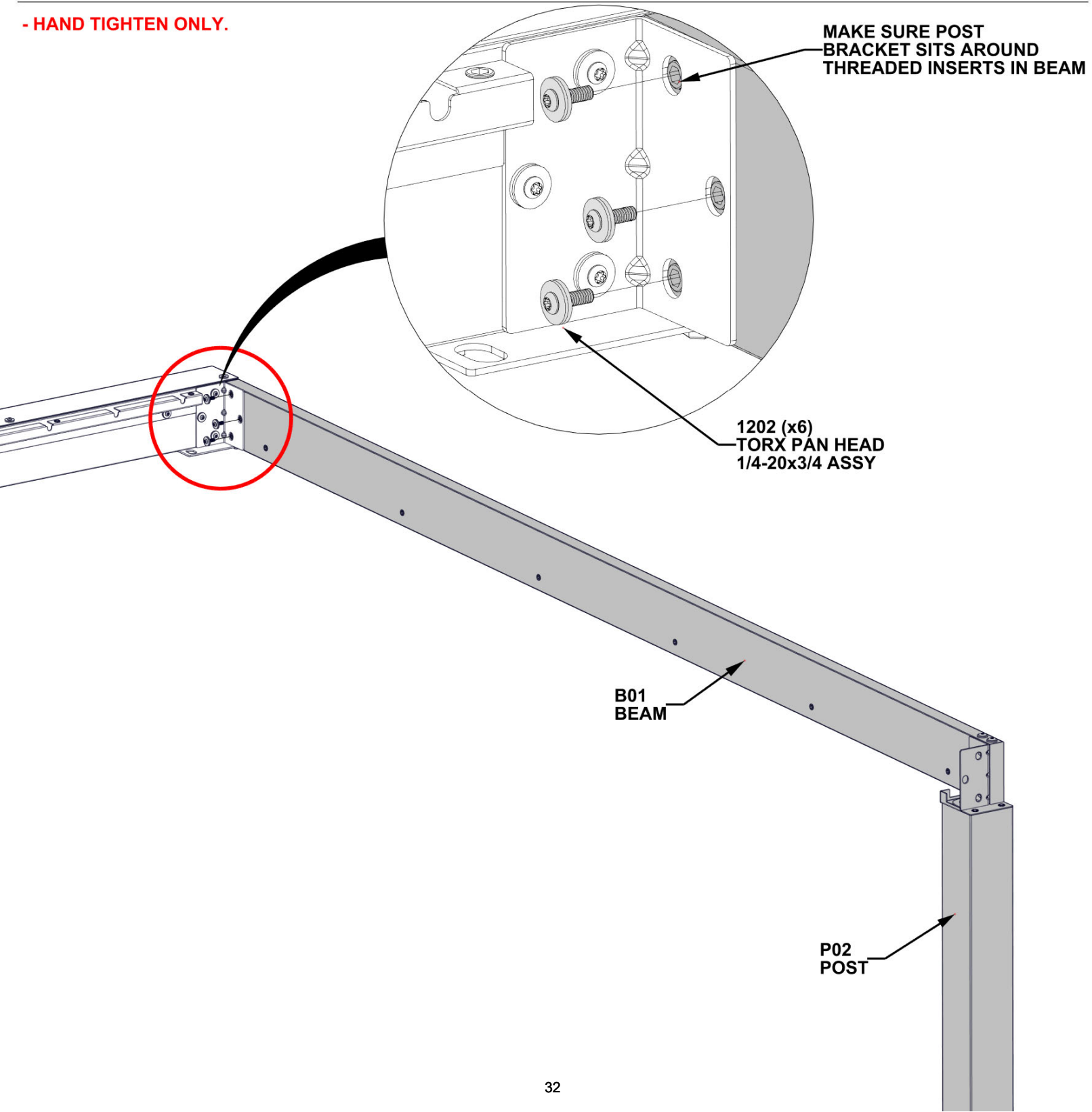

STEP 11A - RIGHT GUTTER ASSEMBLY

QTY	PART NUMBER	DESCRIPTION
6	H101202	TORX PAN HEAD 1/4-20x3/4 ASSY

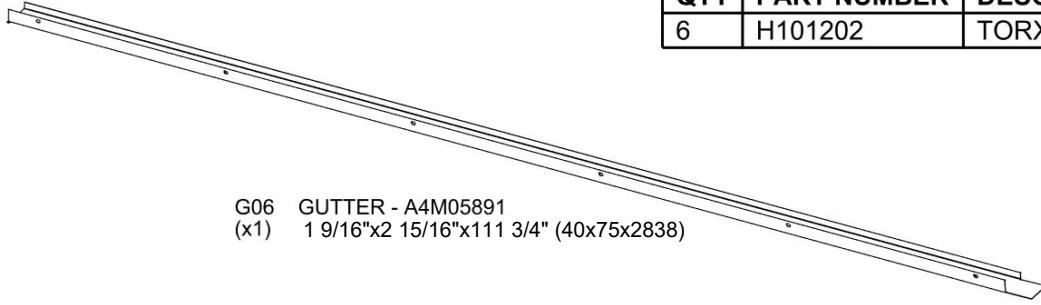

G06 GUTTER - A4M05891
(x1) 1 9/16"x2 15/16"x111 3/4" (40x75x2838)

- WITH AN ADDITIONAL PERSON, ATTACH GUTTER TO BEAM.
- MAKE SURE ENDS OF GUTTER SIT ON TOP SURFACE OF EACH POST BRACKET.
- TIGHTEN ALL HARDWARE FROM PREVIOUS STEPS.

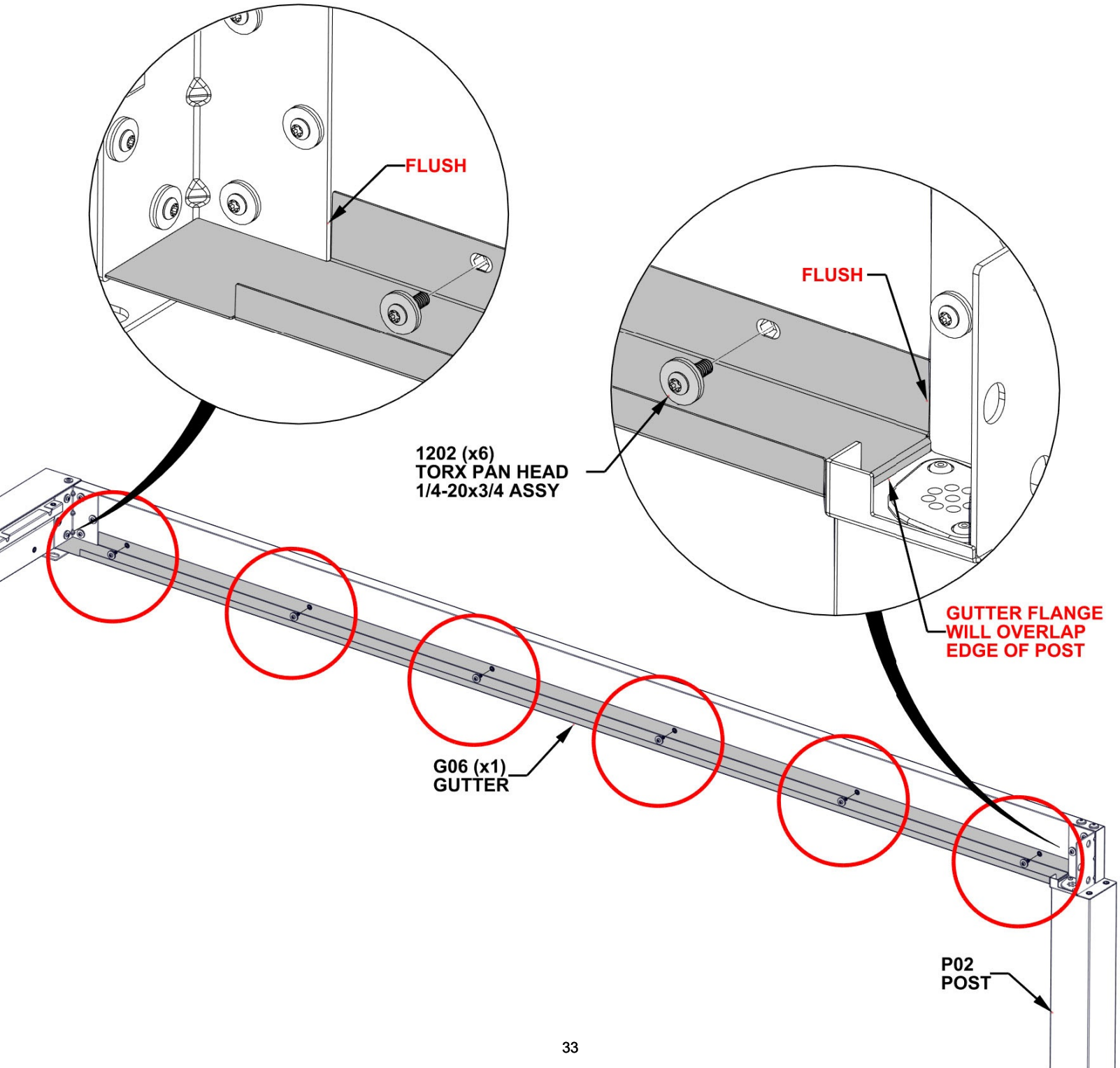

STEP 11B - REAR GUTTER ASSEMBLY



G05 GUTTER SPLICE - A4M05889
(x1) 1 7/16"x3 1/16"x3 15/16" (62x77.5x100)



A6P00796 SILICONE
(x1)

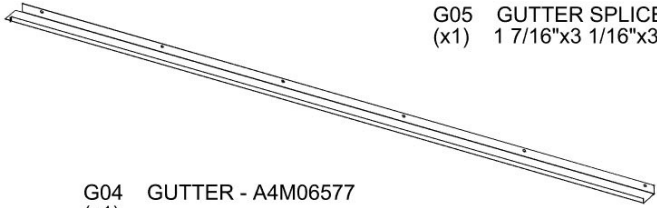

G04 GUTTER - A4M06577
(x1) 1 3/8"x3 1/4"x100 9/16" (35x82x2555)

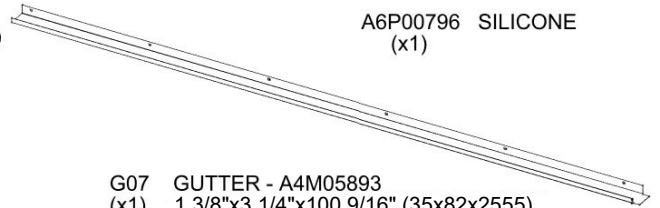

G07 GUTTER - A4M05893
(x1) 1 3/8"x3 1/4"x100 9/16" (35x82x2555)

- MEASURE APPROXIMATELY 1/2" [13mm] FROM EACH END OF GUTTER SPLICE AND APPLY A FINE BEAD OF SILICONE.
- SLIDE BOTH G04 AND G07 GUTTERS INTO SPLICE, ALIGNING SLOTS (ENDS WILL ALMOST BE TOUCHING).
- WIPE OFF ANY EXCESS SILICONE USING A RAG OR PAPER TOWEL.
- GLOVES ARE RECOMMENDED WHEN APPLYING SILICONE.
- MAKE SURE SURFACE OF GUTTER SPLICE IS CLEAN, DRY, AND FREE OF ANY DIRT/DEBRIS.

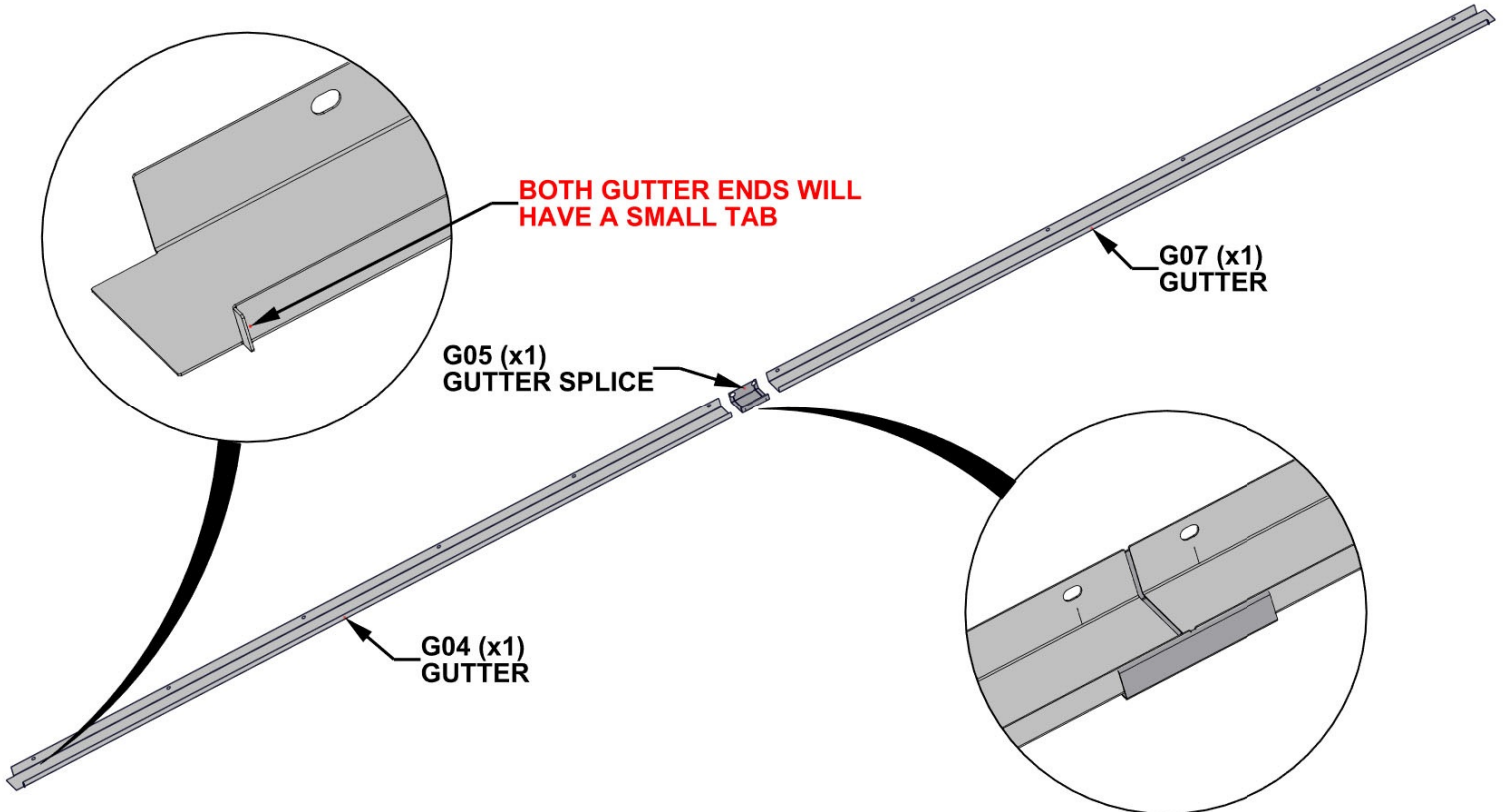
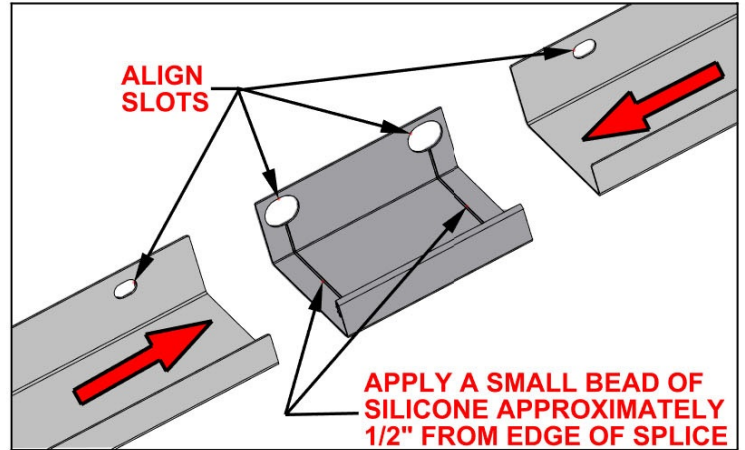

STEP 11C - GUTTER ATTACHMENT

QTY	PART NUMBER	DESCRIPTION
12	H101202	TORX PAN HEAD 1/4-20x3/4 ASSY

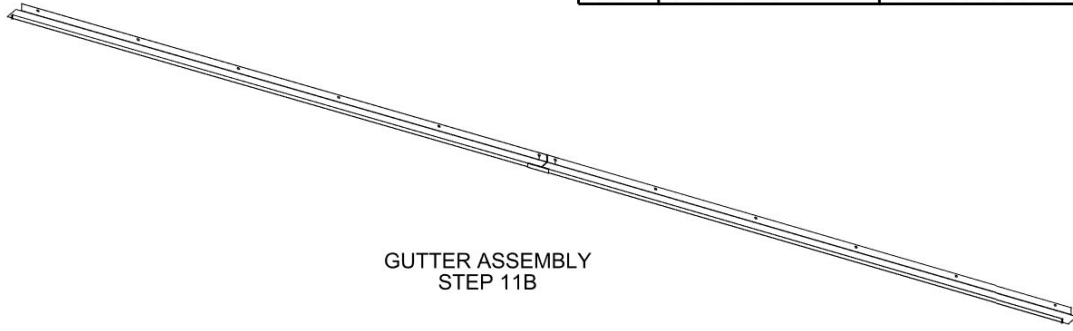

- WITH AT LEAST TWO PEOPLE, ATTACH GUTTER ASSEMBLY FROM PREVIOUS STEP TO BEAM.
- ENSURE TABS ON GUTTER ARE POSITIONED ON THE INSIDE OF THE SIDE GUTTERS.

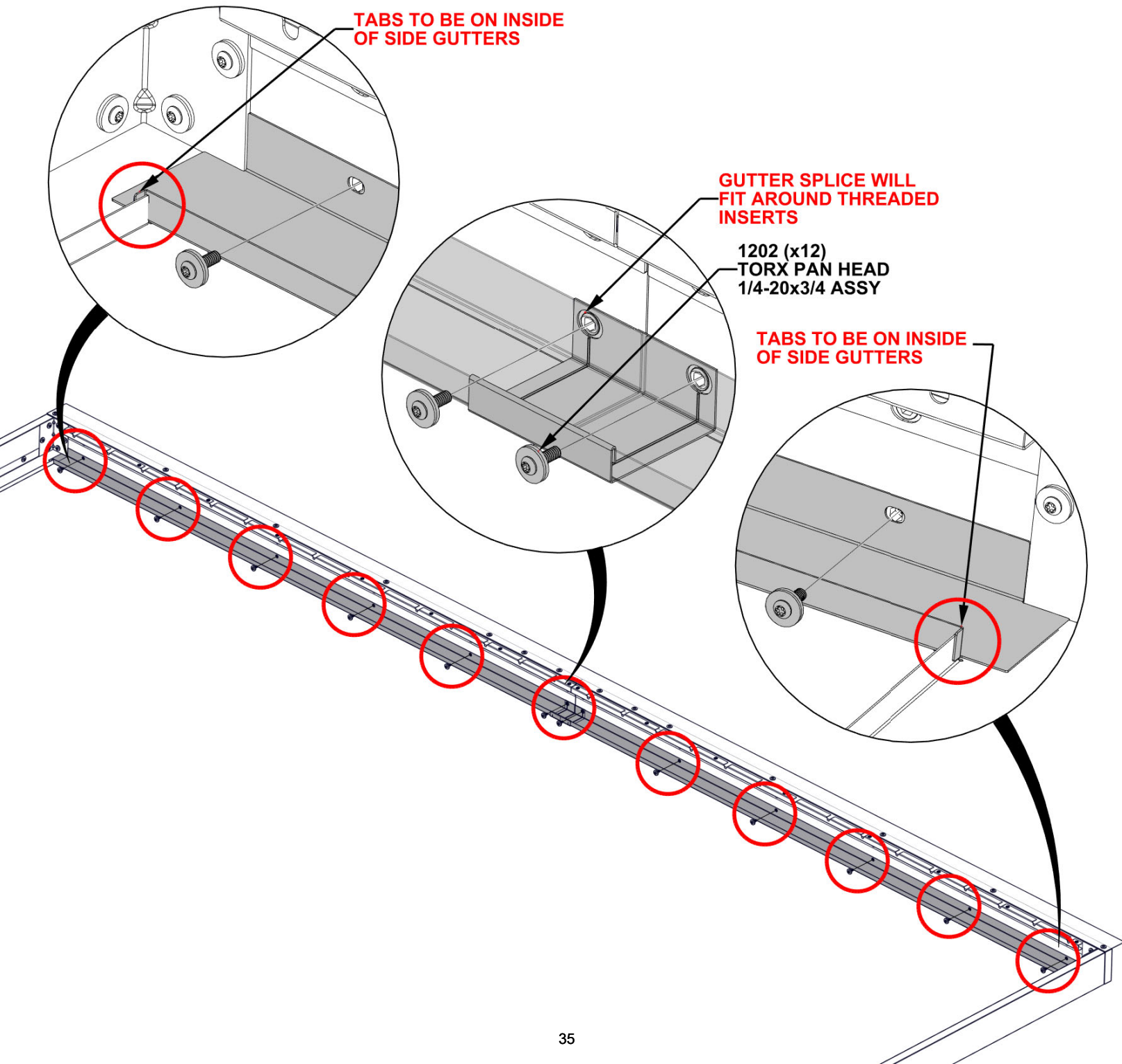

STEP 12 - FRONT BEAM ASSEMBLY

QTY	PART NUMBER	DESCRIPTION
6	H101202	TORX PAN HEAD 1/4-20x3/4 ASSY



B06 BEAM - A4M05895
(x1) 1 7/16"x5 1/4"x103 7/8" (36x134x2638)



J2 SPLICE BRACKET ASSY - A4M06579
(x1) 39 1/2"x5 1/8"x1 1/4" (32.00x131x500)

- BEAM AND SPLICE MUST BE ORIENTED AS SHOWN BELOW.
SLIDE J2 INTO B06 AND LINE UP THREE HOLES TOP AND BOTTOM.
- HAND TIGHTEN ONLY.

**NOTE DIRECTIONAL
ARROW FOR CORRECT
ORIENTATION**

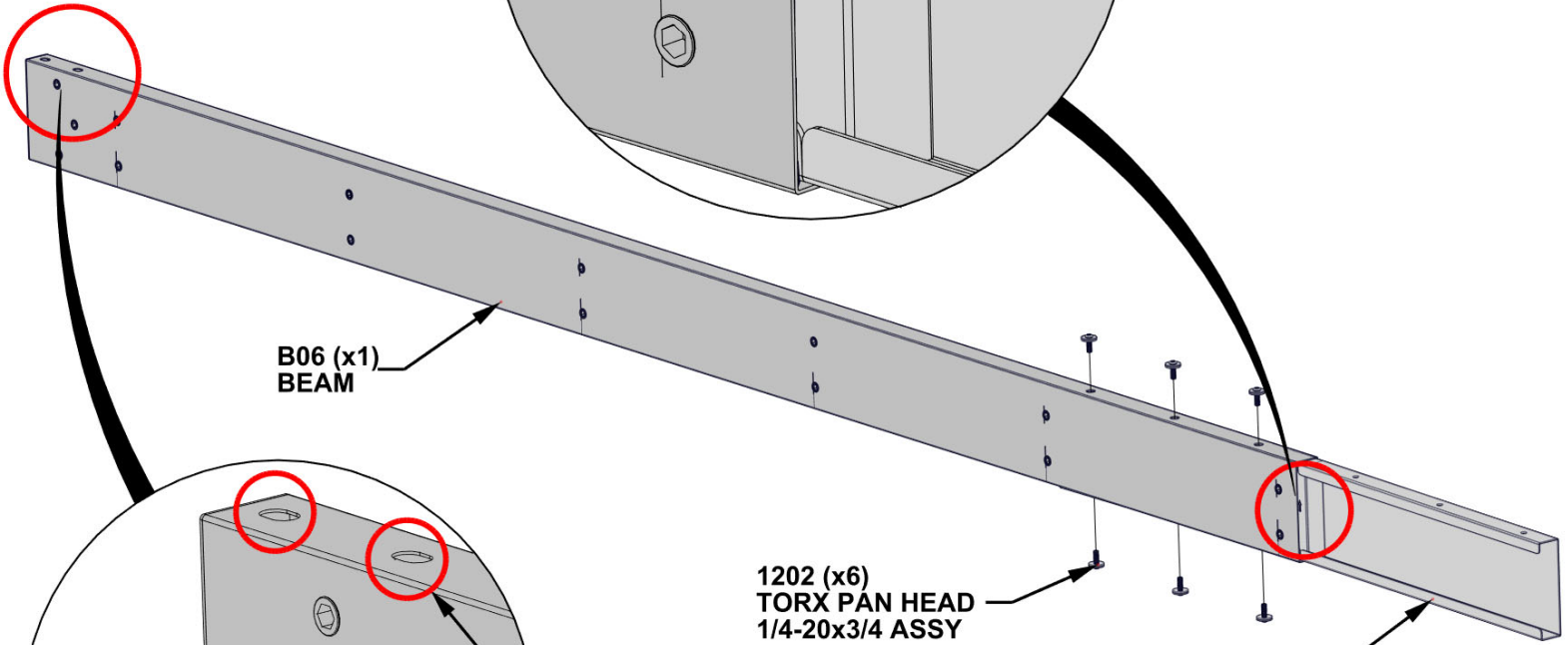
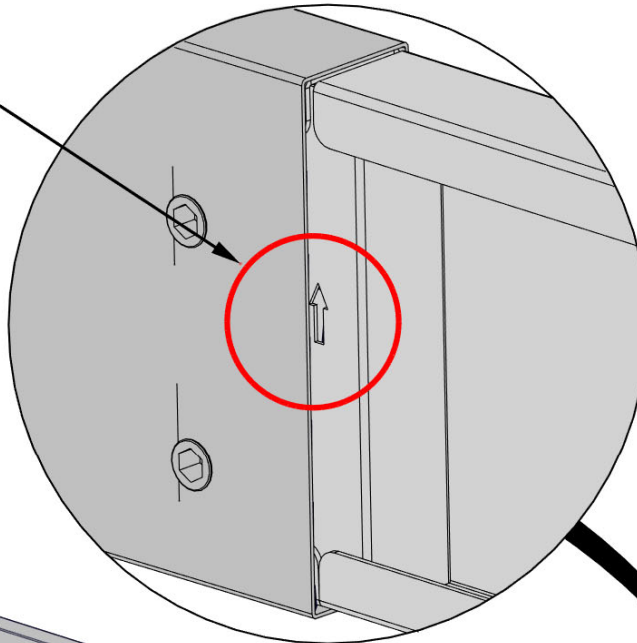

B06 (x1)
BEAM

1202 (x6)
TORX PAN HEAD
1/4-20x3/4 ASSY

J2 (x1)
SPLICE BRACKET ASSY

**SMALLER SLOTS ARE
TO FACE UPWARDS**

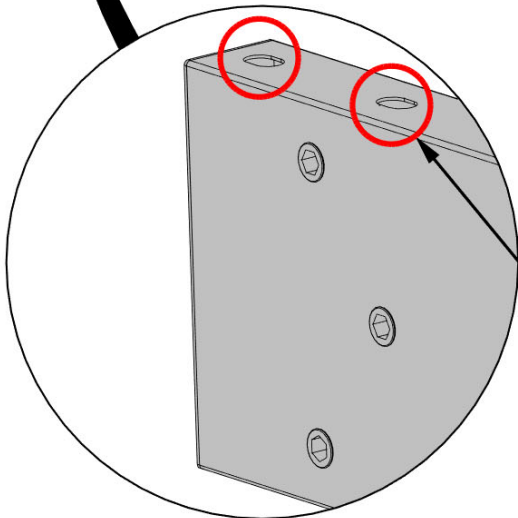

STEP 13 - FRONT BEAM ASSEMBLY

Qty	PartNo	Description
6	H101202	TORX PAN HEAD 1/4-20x3/4 ASSY



B04 BEAM - A4M05894
(x1) 1 7/16"x5 1/4"x103 7/8" (36x134x2639)

- SLIDE B04 ONTO SPLICE BRACKET.
- GENTLY TAP ENDS OF ASSEMBLY WITH RUBBER Mallet UNTIL GAP CLOSES, THEN TIGHTEN ALL BOLTS ON BEAM.

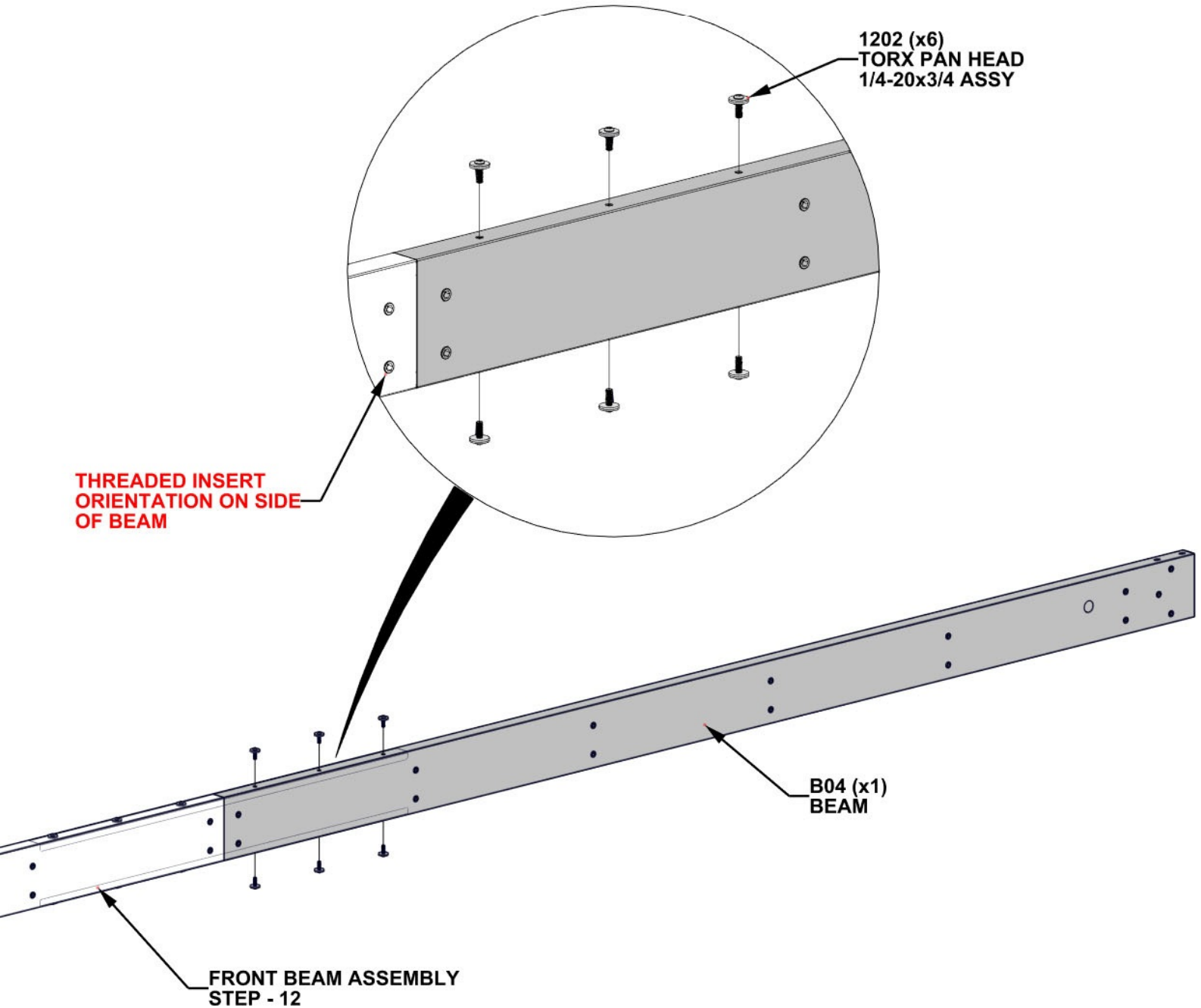

STEP 14A - FRONT FRAME ASSEMBLY

Qty	PartNo	Description
4	H101230	BOLT WH 5/16x6 S.S.

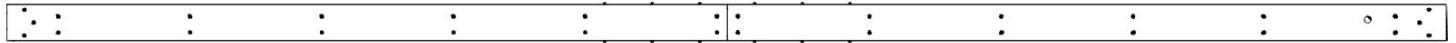

BEAM ASSEMBLY
STEP - 13

- WITH AT LEAST TWO EXTRA PEOPLE, ATTACH BEAM ASSEMBLY FROM PREVIOUS STEPS TO P02 AND P03 POST.
- ALIGN SLOTS IN BEAM WITH THREADED INSERTS ON TOP PLATE. FLUSH ALL SIDES OF BEAM AND POST.
- HAND TIGHTEN ONLY.

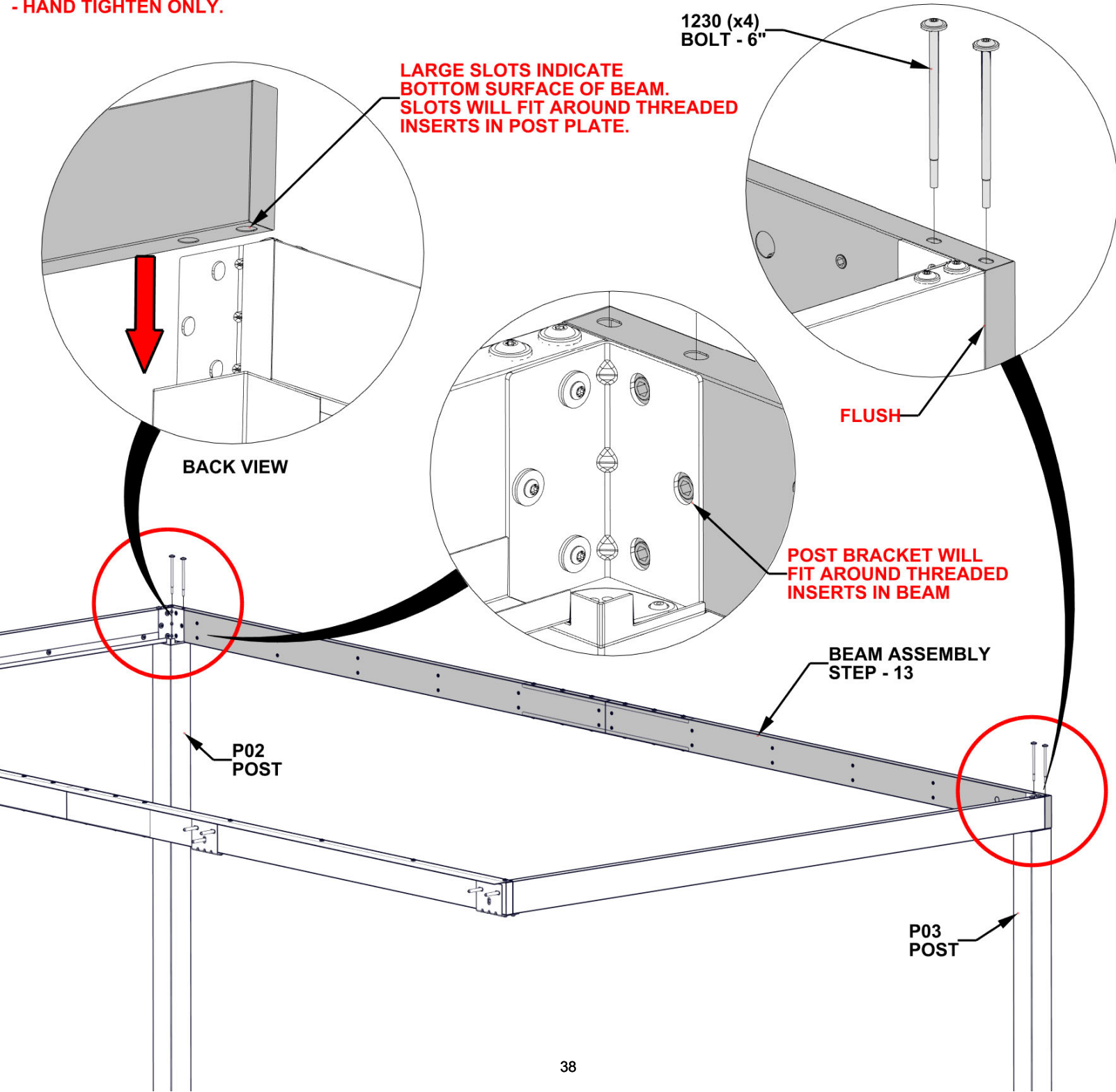

STEP 14B - FRONT FRAME ASSEMBLY

Qty	PartNo	Description
6	H101202	TORX PAN HEAD 1/4-20x3/4 ASSY

- TIGHTEN ALL HARDWARE FROM PREVIOUS STEPS.

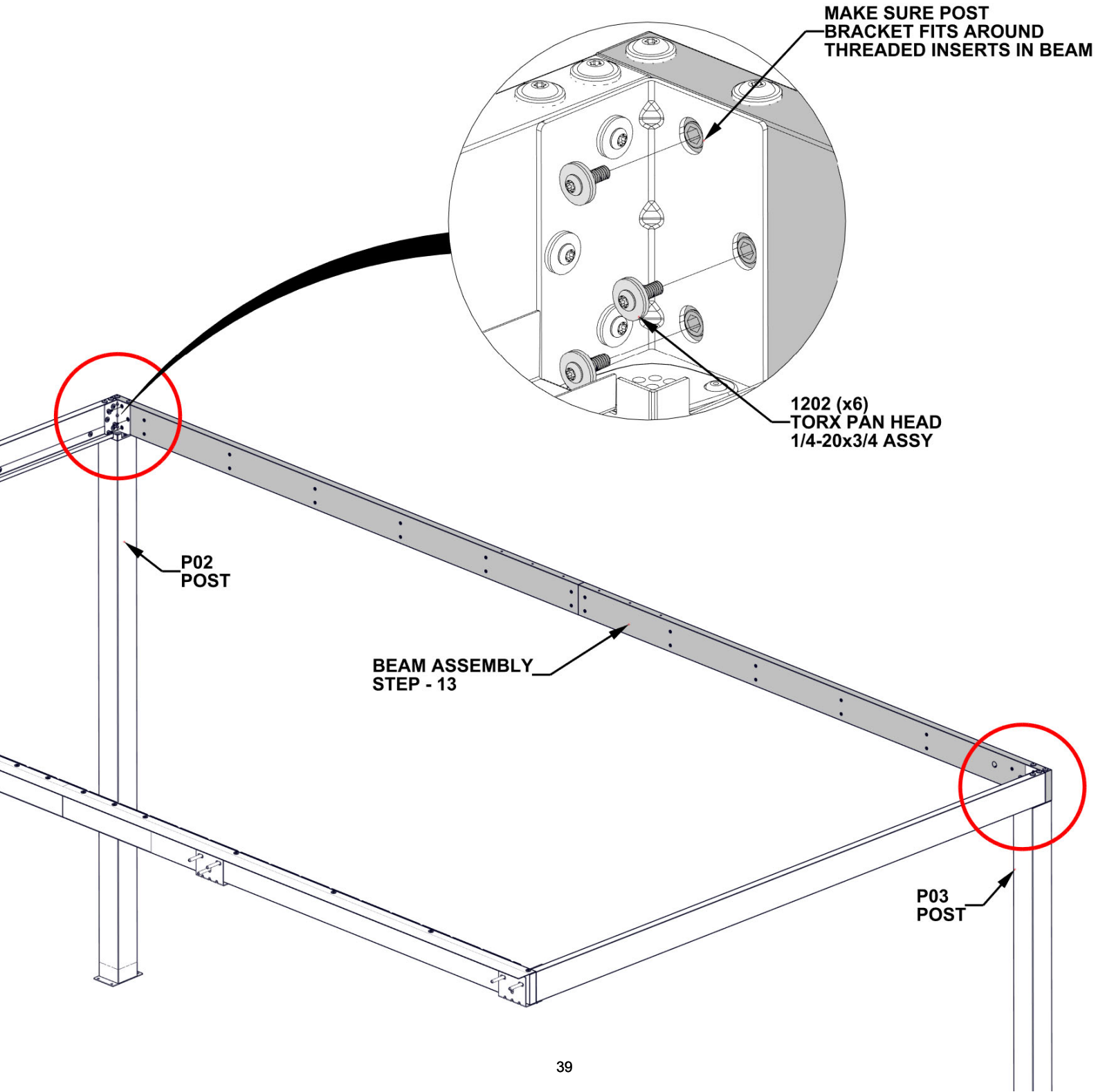

STEP 15 - FRONT BEAM LOUVER MOUNT ATTACHMENT

Qty	PartNo	Description
6	H101202	TORX PAN HEAD 1/4-20x3/4 ASSY

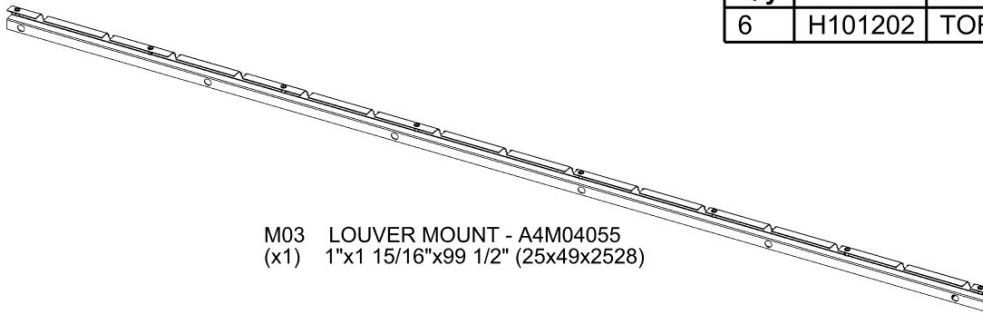

**FLUSH MOUNT WITH
EDGE OF POST BRACKET**

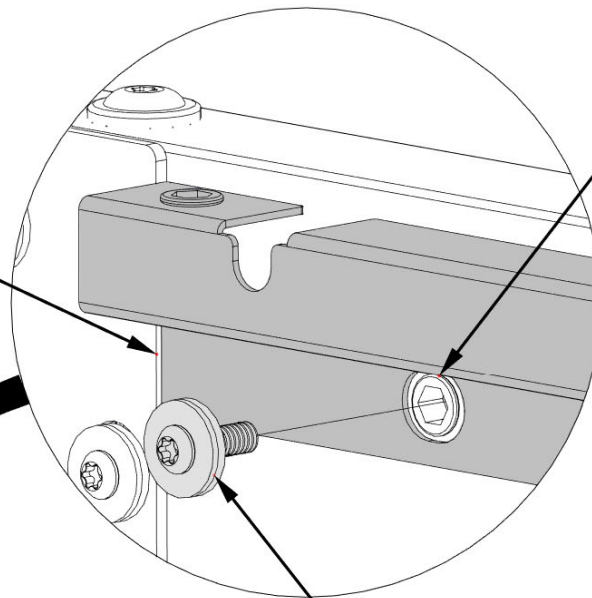

**LOUVER MOUNT WILL
FIT AROUND THREADED
INSERTS IN BEAM**

**1202 (x6)
TORX PAN HEAD
1/4-20x3/4 ASSY**

**M03 (x1)
LOUVER MOUNT**

**P02
POST**

STEP 16 - FRONT BEAM LOUVER MOUNT ATTACHMENT

Qty	PartNo	Description
6	H101202	TORX PAN HEAD 1/4-20x3/4 ASSY

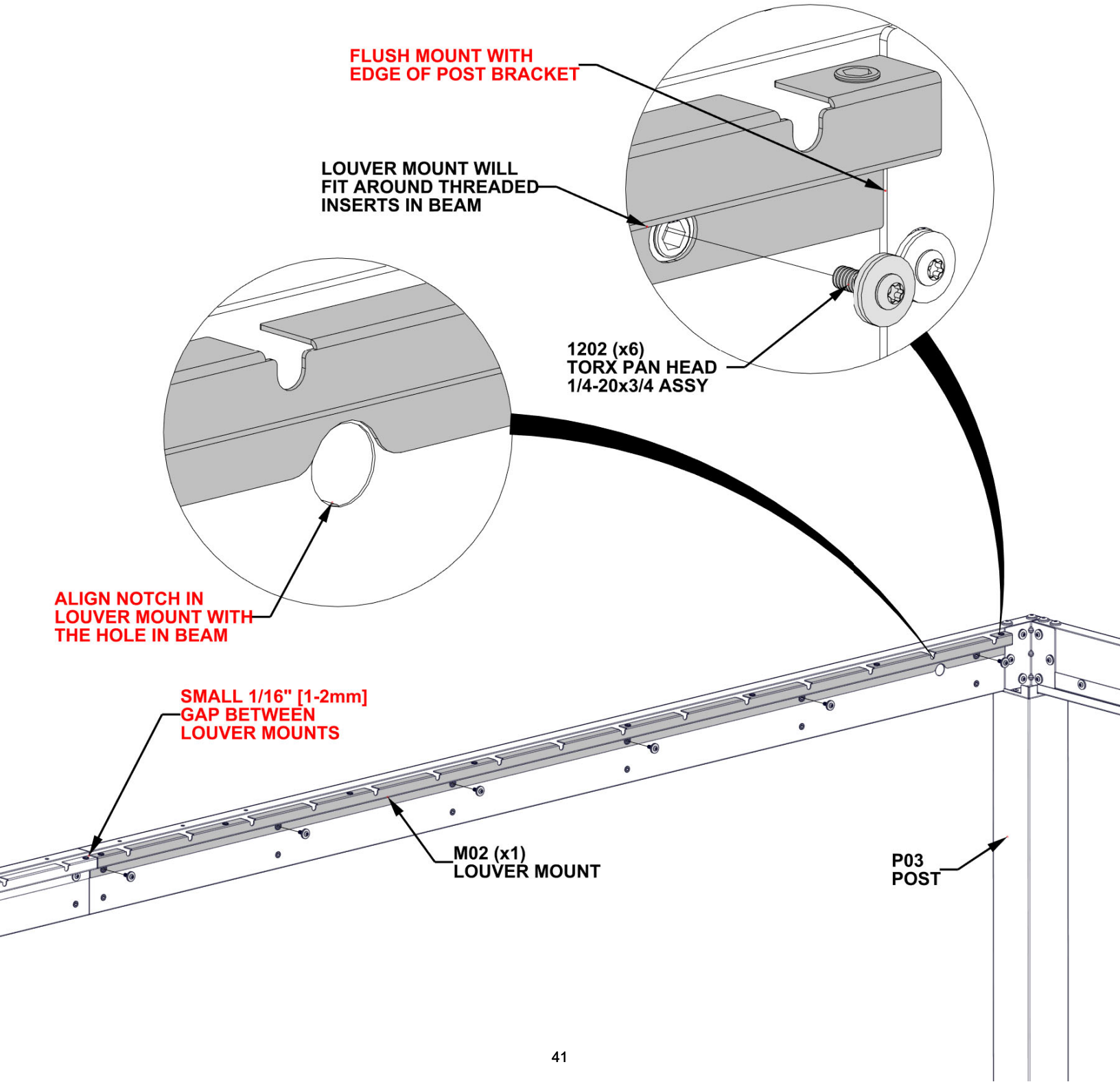
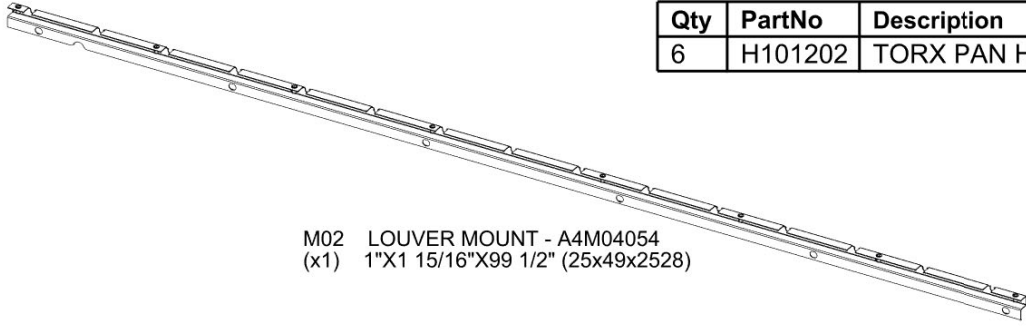

STEP 17A - FRONT BEAM GUTTER ATTACHMENT

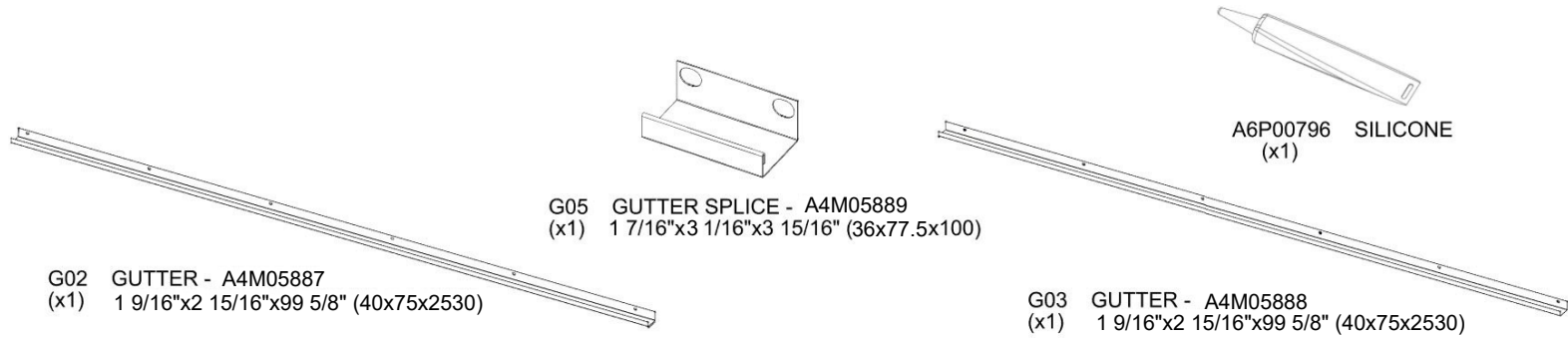

- MEASURE APPROXIMATELY 1/2" [13mm] FROM EACH END OF GUTTER SPLICE AND APPLY A FINE BEAD OF SILICONE.
- SLIDE BOTH G03 AND G04 GUTTERS INTO SPLICE, ALIGNING SLOTS (ENDS WILL ALMOST BE TOUCHING).
- WIPE OFF ANY EXCESS SILICONE USING A RAG OR PAPER TOWEL.
- **GLOVES ARE RECOMMENDED WHEN APPLYING SILICONE.**
- **MAKE SURE SURFACE OF GUTTER SPLICE IS CLEAN, DRY, AND FREE OF ANY DIRT/DEBRIS.**

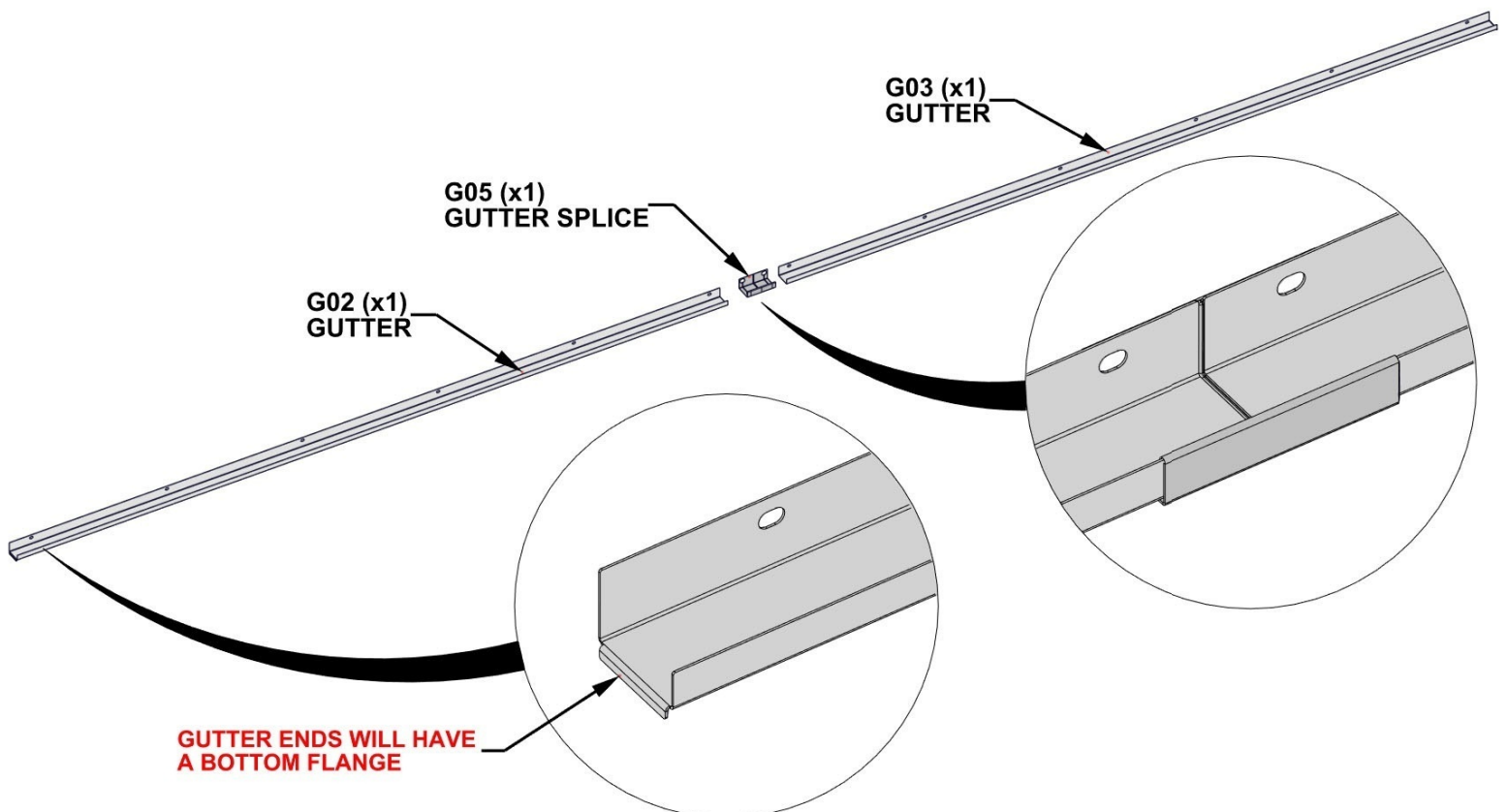
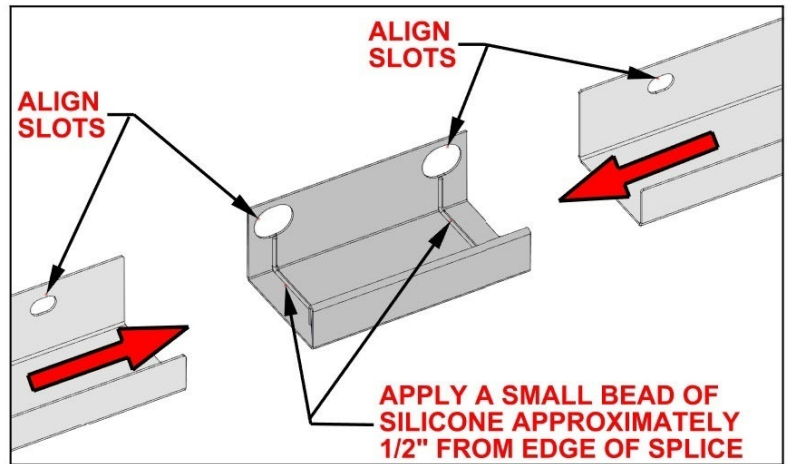

STEP 17B - FRONT BEAM GUTTER ASSEMBLY

QTY	PART NUMBER	DESCRIPTION
12	H101202	TORX PAN HEAD 1/4-20x3/4 ASSY

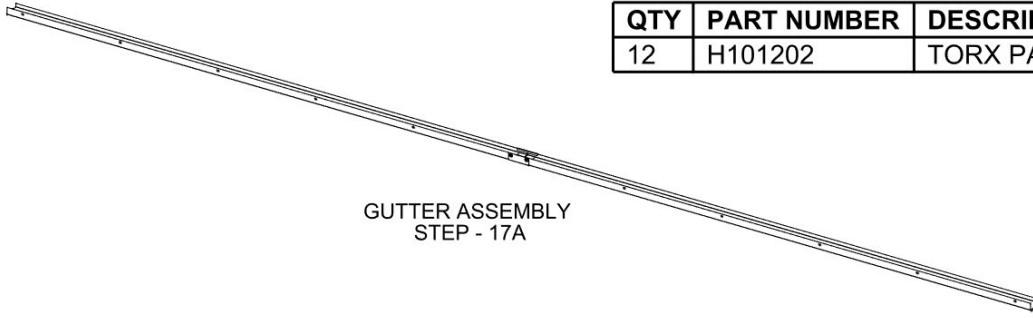

- WITH AT LEAST TWO PEOPLE ATTACH GUTTER ASSEMBLY FROM PREVIOUS STEP TO BEAM.
- MAKE SURE ENDS OF GUTTER SIT ON TOP SURFACE OF EACH POST BRACKET.

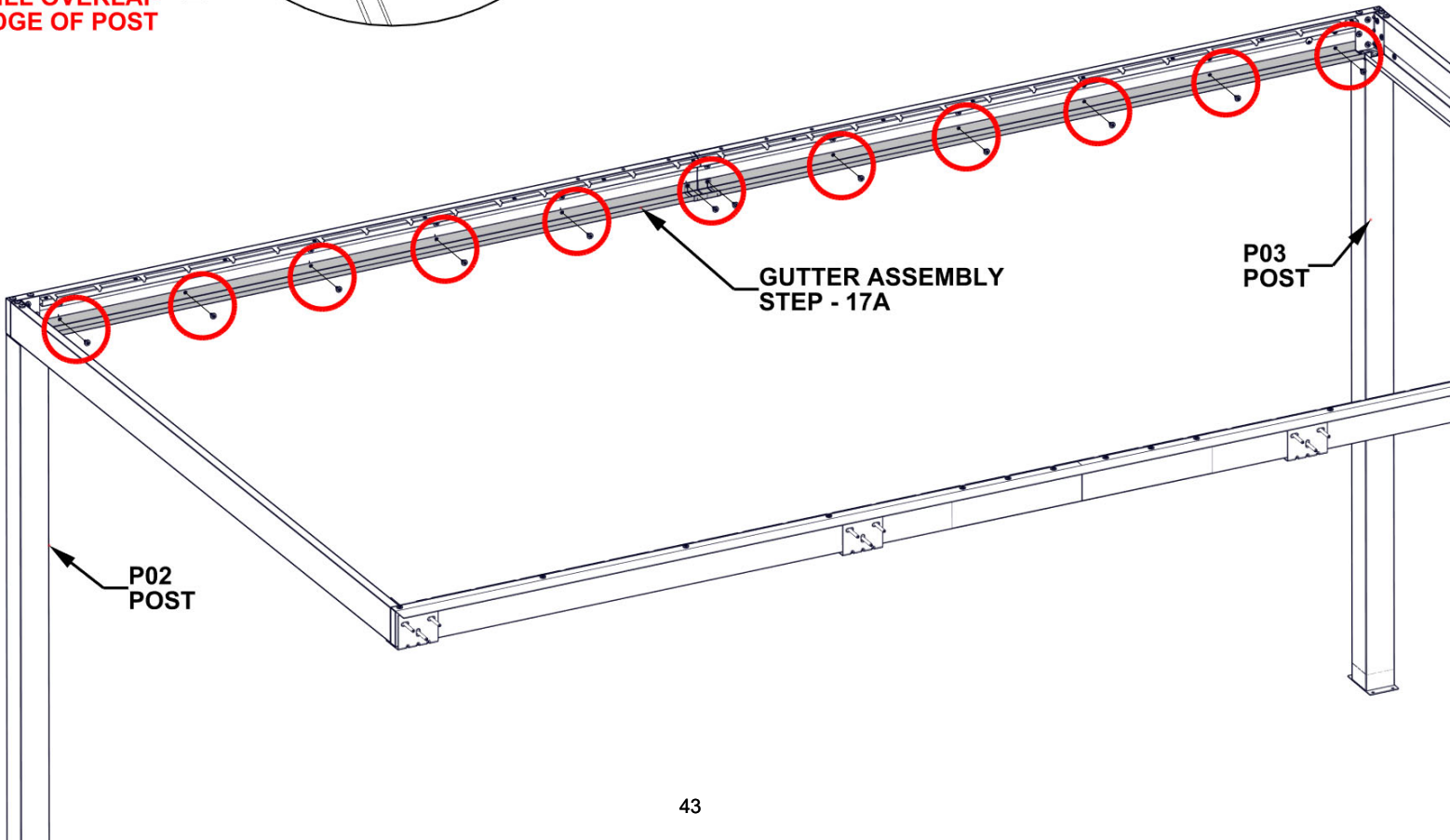
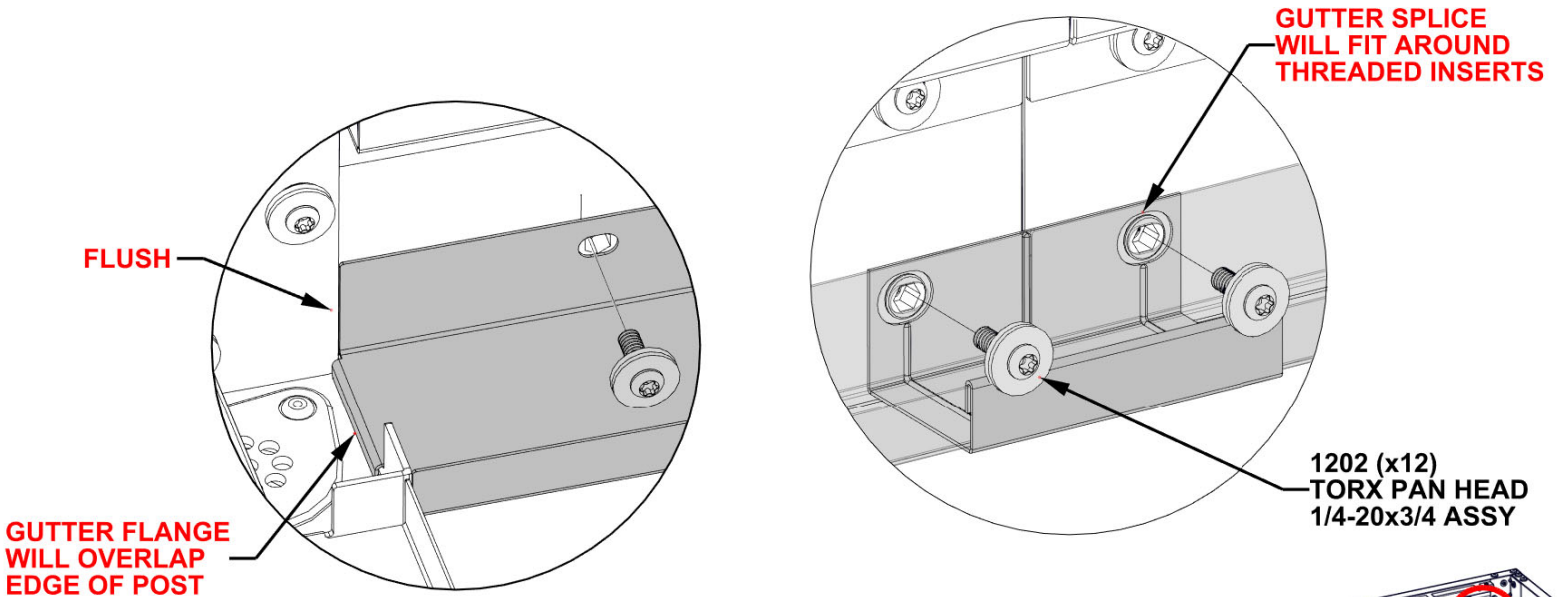

STEP 17C - FRONT BEAM GUTTER ATTACHMENT

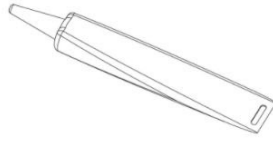

A6P00796 SILICONE
(x1)

- APPLY A FINE BEAD OF SILICONE ALONG INSIDE SURFACE OF GUTTER WHERE TWO GUTTER PIECES MEET.
- SMOOTH SILICONE ALONG SEAM. WIPING EXCESS USING A RAG OR PAPER TOWEL.
- **GLOVES ARE RECOMMENDED WHEN APPLYING SILICONE.**
- **MAKE SURE SURFACE OF GUTTER IS CLEAN, DRY, AND FREE OF ANY DIRT/DEBRIS.**

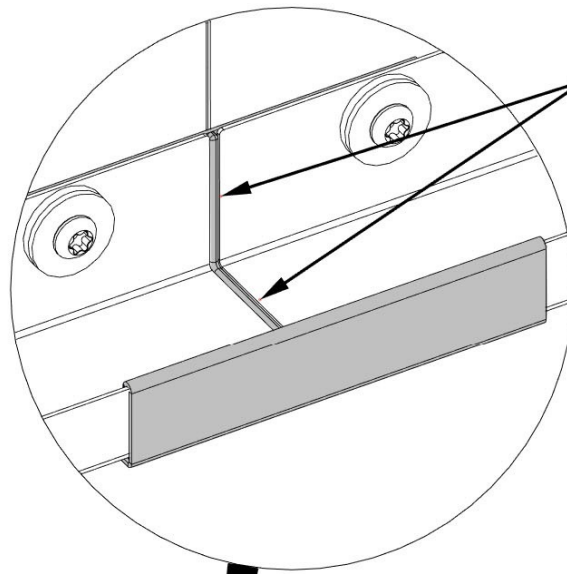

**APPLY A FINE
BEAD OF SILICONE
ALONG INSIDE SEAM
OF GUTTER**

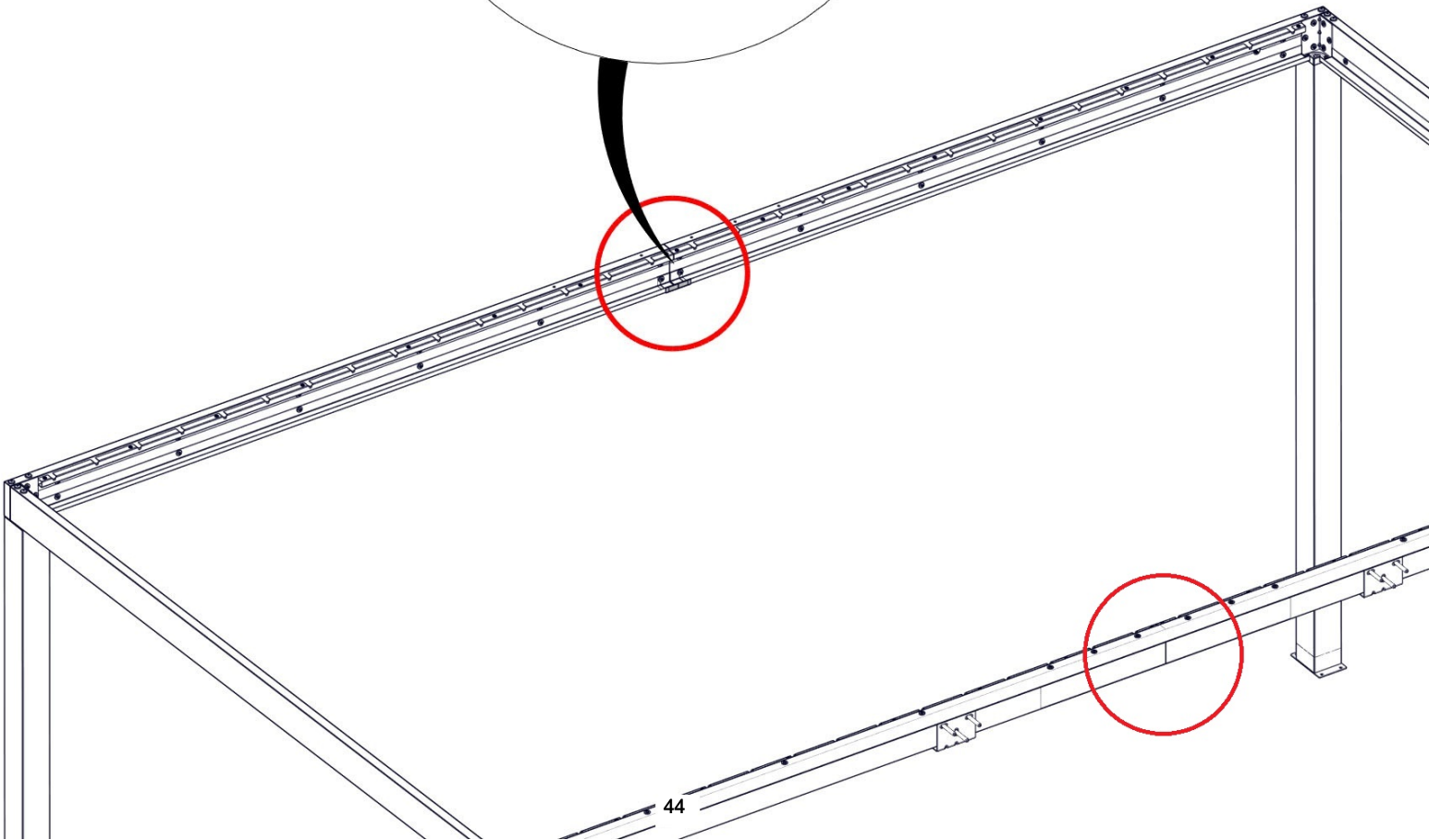

STEP 18 - SQUARE STRUCTURE

**CRITICAL: SQUARE ASSEMBLY BEFORE PROCEEDING TO NEXT STEPS.
ONCE SQUARE, MAKE SURE ALL HARDWARE HAS BEEN
TIGHTENED FROM PREVIOUS STEPS.**

MEASUREMENTS TAKE FROM OUTSIDE CORNER TO OUTSIDE CORNER OF STRUCTURE

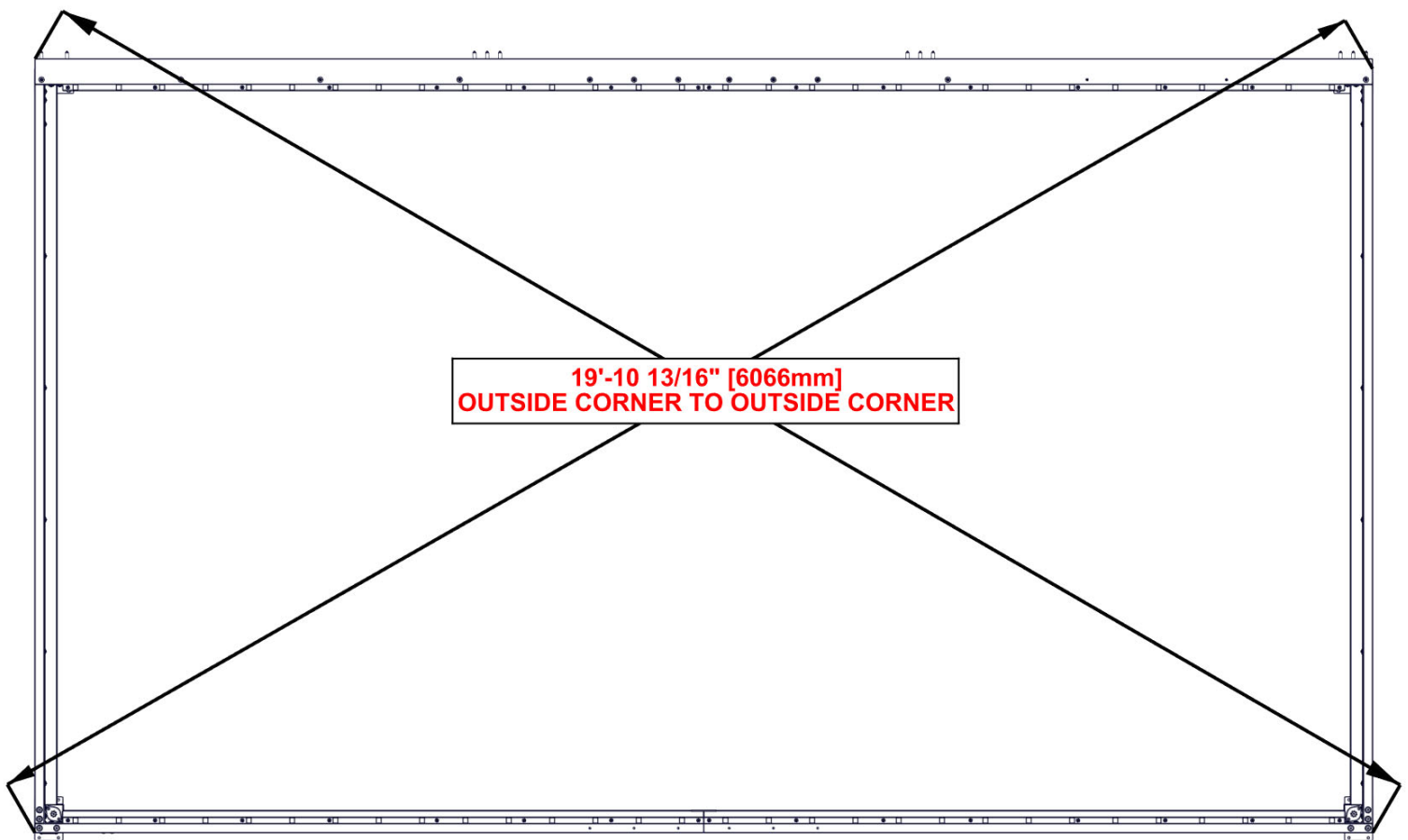

STEP 19 - GUTTER SEALANT



A6P00796 SILICONE
(x1)

- APPLY A FINE BEAD OF SILICONE ALONG INSIDE SURFACE OF GUTTER WHERE GUTTER PIECES MEET POST.
- SMOOTH SILICONE, WIPING EXCESS USING A RAG OR PAPER TOWEL.
- GLOVES ARE RECOMMENDED WHEN APPLYING SILICONE.
- MAKE SURE SURFACE OF GUTTER IS CLEAN, DRY, AND FREE OF ANY DIRT/DEBRIS.
- REPEAT THIS STEP FOR ALL GUTTER ATTACHMENT POINTS AT EACH POST.

APPLY A FINE BEAD OF SILICONE TO PREVENT WATER FROM LEAKING

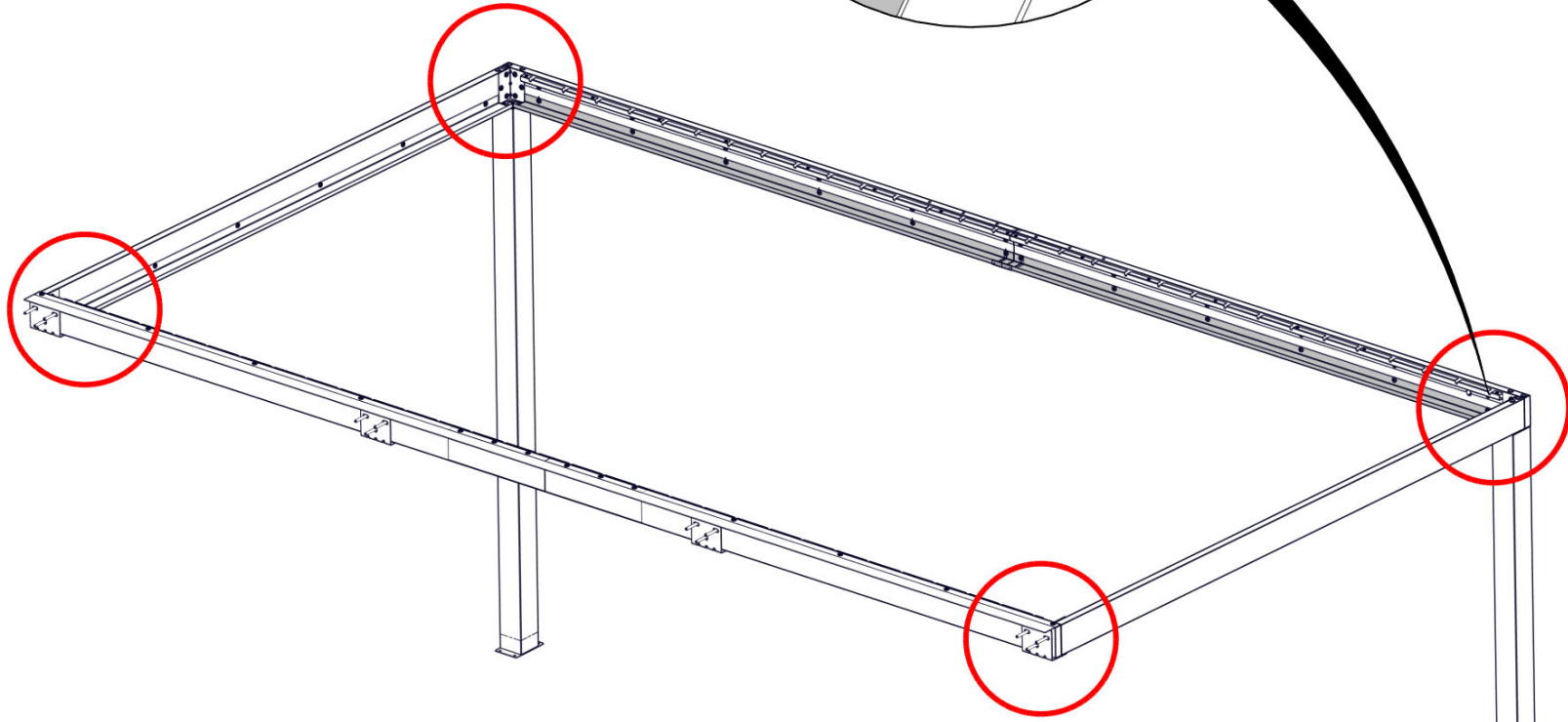
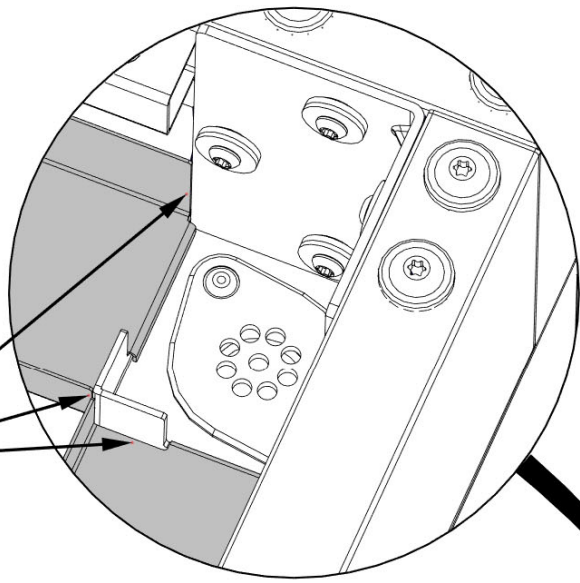

STEP 20 - DRIVE LOUVER INSTALLATION

Qty	PartNo	Description
4	H100408	SCREW PWH 8x1/2 BLK

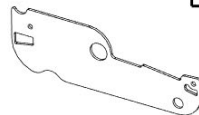

L02 LOUVER DRIVE SIDE PLATE - A4M04139
(x1) 1/16"x2 3/16"x6 9/16" (2x55x167)



L03 LOUVER SIDE PLATE - A4M04138
(x1) 1/16"x2 3/16"x6 9/16" (2x55x167)

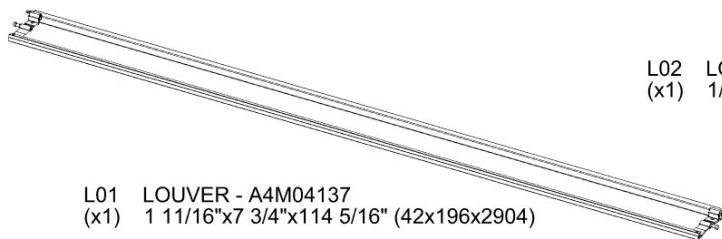

L01 LOUVER - A4M04137
(x1) 1 11/16"x7 3/4"x114 5/16" (42x196x2904)

- DO NOT OVERTIGHTEN SCREWS.

- FOR EASE OF ASSEMBLY, WE RECOMMEND USING SAWHORSES FOR THIS STEP

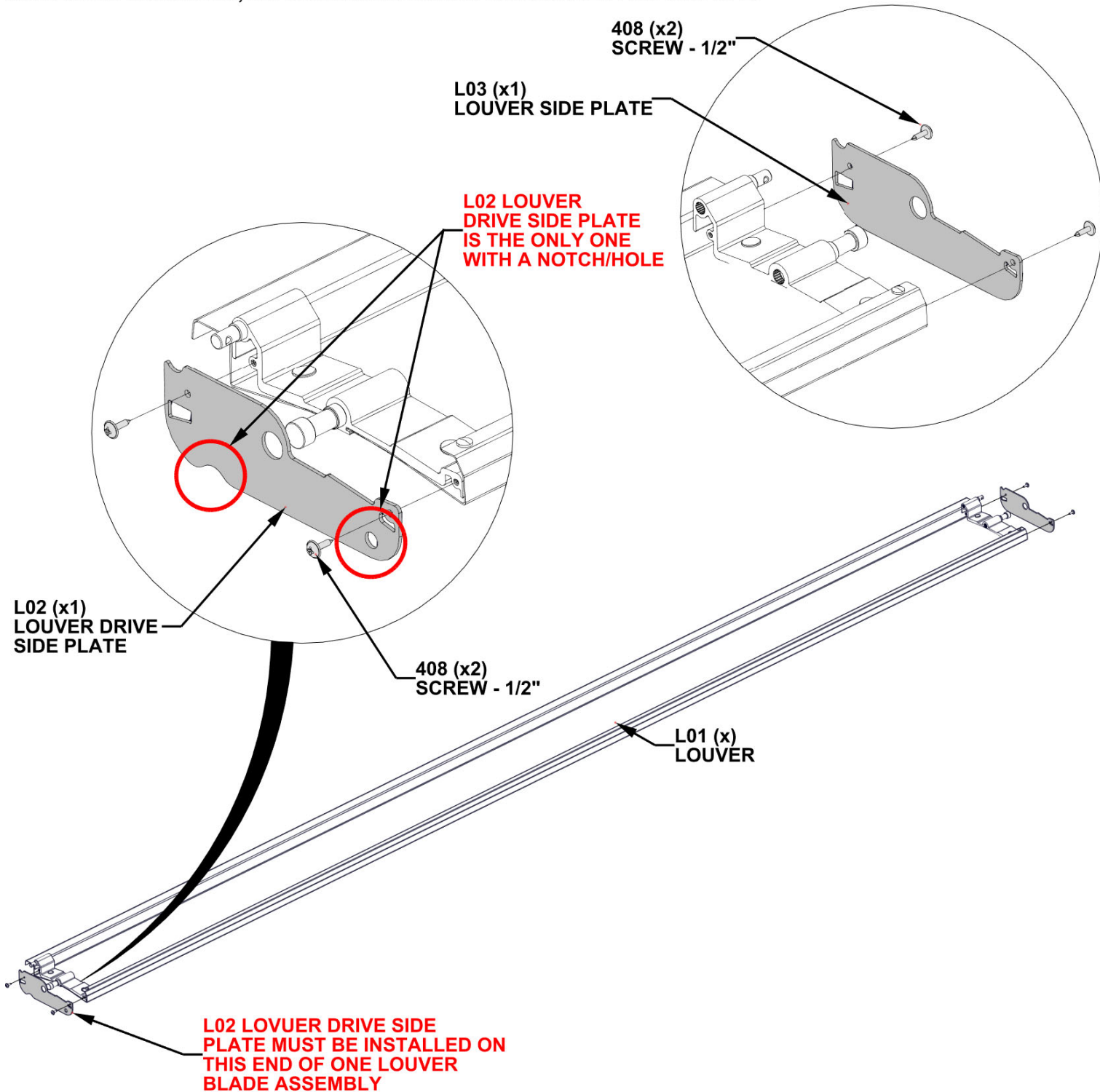

STEP 21 - LOUVER INSTALLATION

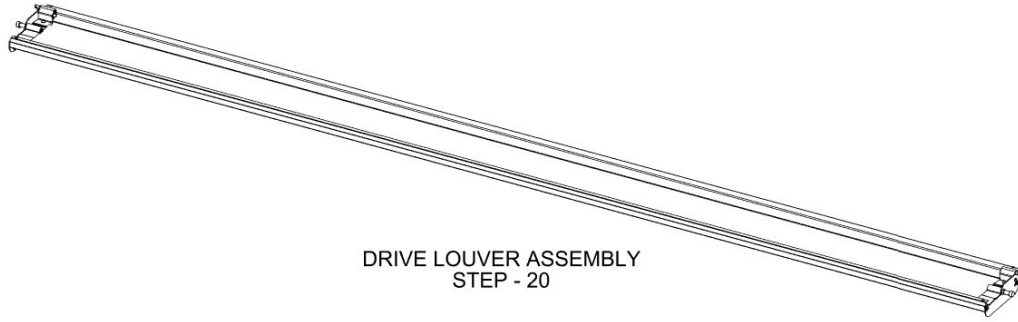

- ORIENTATION OF LOUVER WILL BE DETERMINED BY THE SIDE BEAM WITH FOUR THREADED INSERTS.
- PLACE DRIVE LOUVER FROM PREVIOUS STEP IN THE SECOND SET OF LOUVER MOUNT GROOVES. L02 DRIVE PLATE WILL BE ON THE SAME SIDE AS FOUR THREADED INSERTS IN BEAM.

PLACE DRIVE LOUVER ASSEMBLY IN THE SECOND SET OF LOUVER MOUNT GROOVES

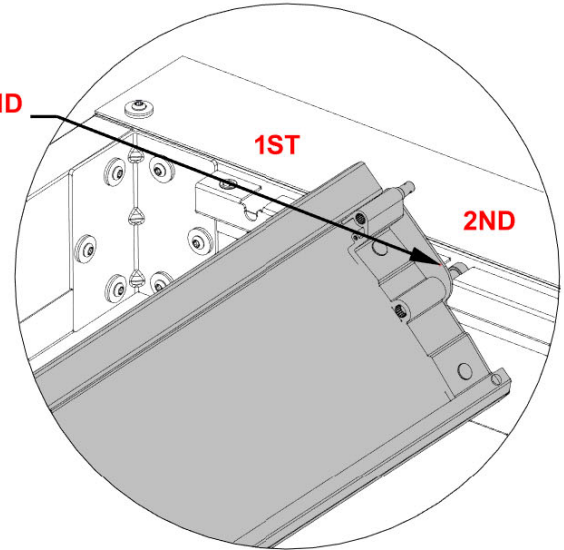

L02 SIDE PLATE MUST BE ON THE SAME END AS THE FOUR THREADED INSERTS

L02 LOUVER DRIVE SIDE PLATE

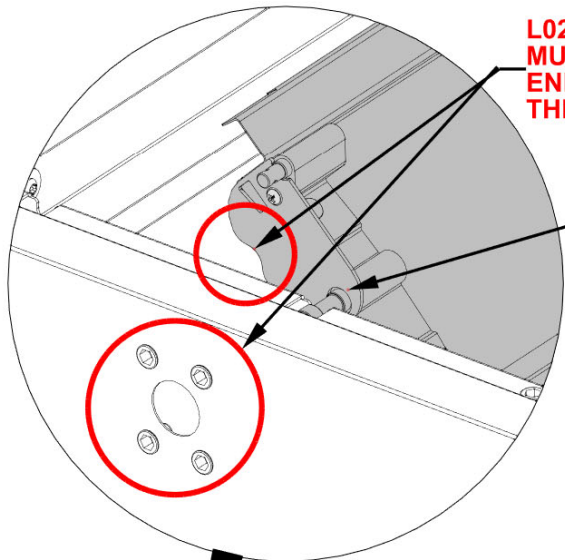

DRIVE LOUVER ASSEMBLY
STEP - 20

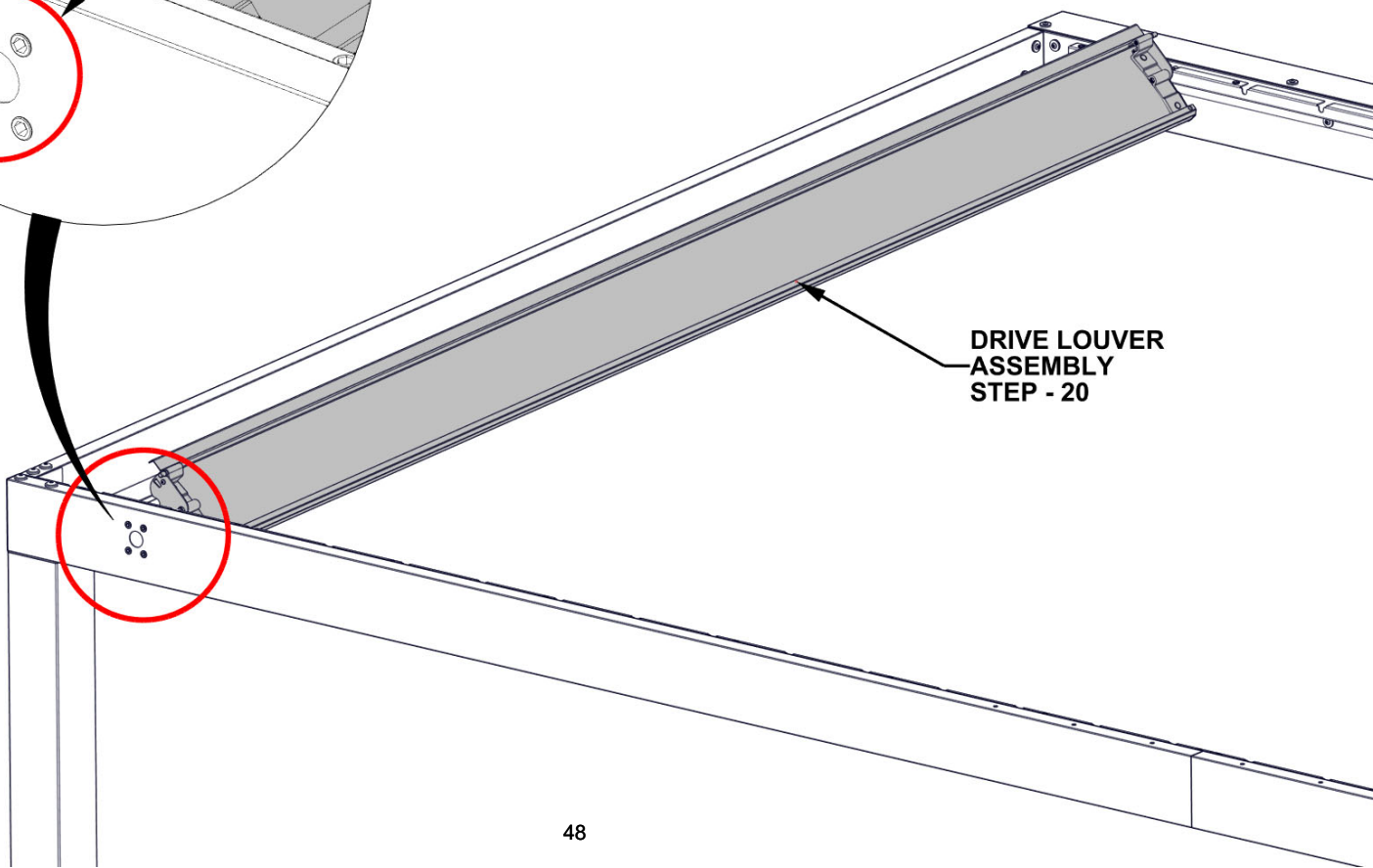

STEP 22 - LOUVER ASSEMBLY

Qty	PartNo	Description
116	H100408	SCREW PWH 8x1/2 BLK

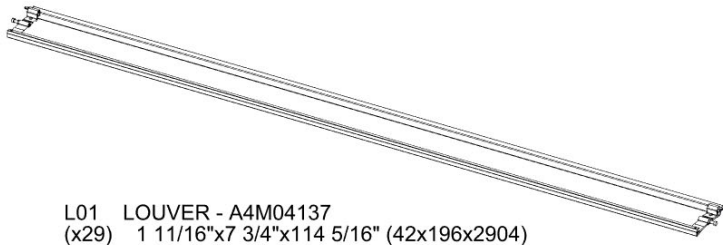

L01 LOUVER - A4M04137
(x29) 1 11/16"x7 3/4"x114 5/16" (42x196x2904)

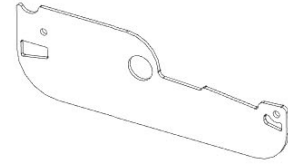

L03 LOUVER SIDE PLATE - A4M04138
(x58) 1/16"x2 3/16"x6 9/16" (2x55x167)

- REPEAT THIS STEP 29 TIMES.
- DO NOT OVERTIGHTEN SCREWS.
- FOR EASE OF ASSEMBLY, WE RECOMMEND USING SAWHORSES FOR THIS STEP.

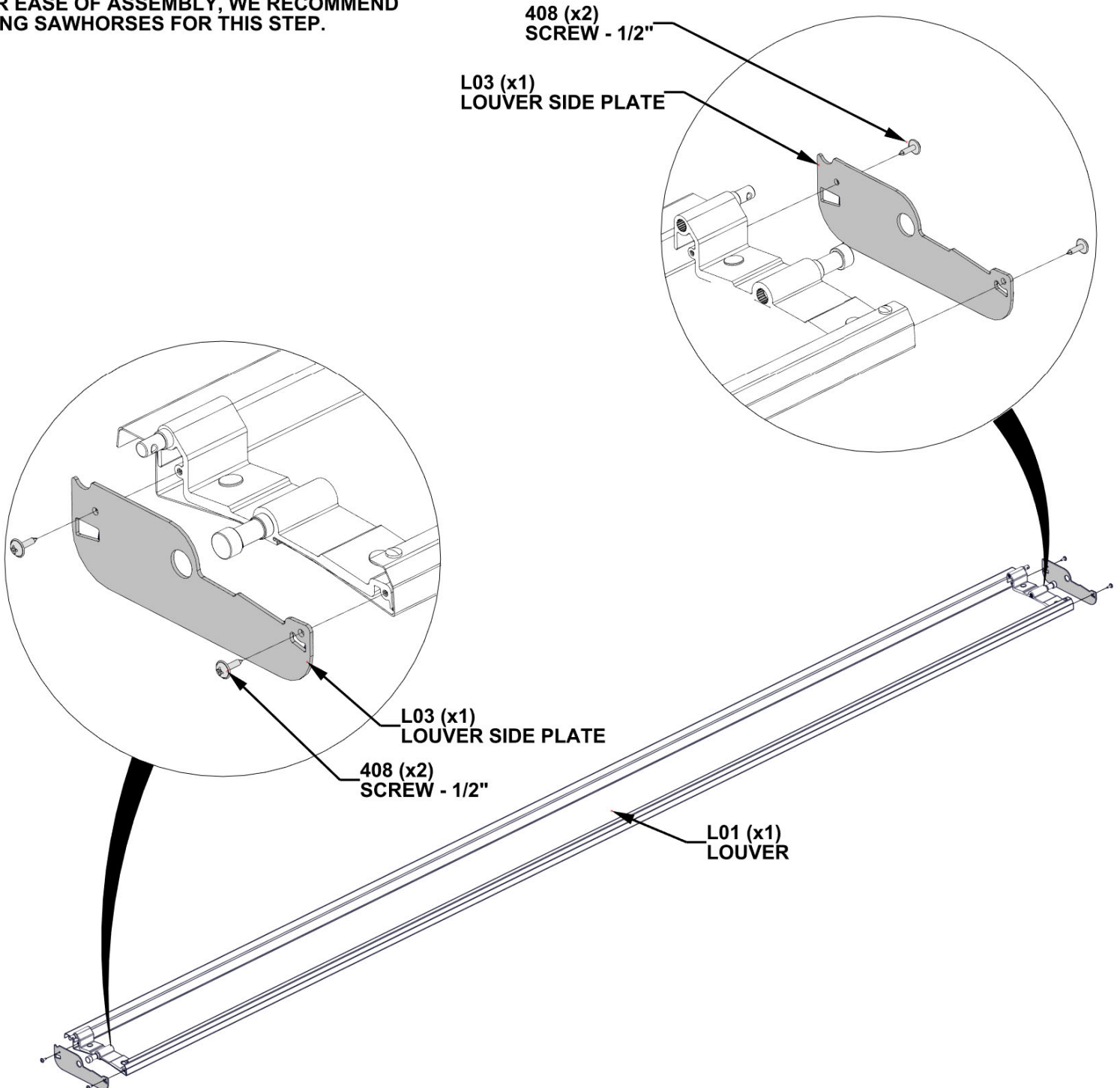

STEP 23A - LOUVER INSTALLATION

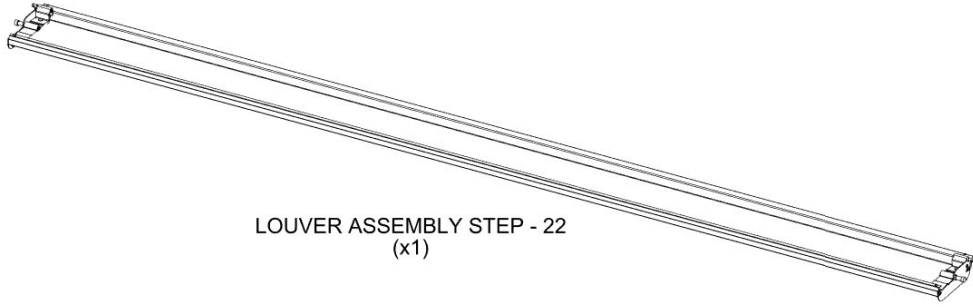

- STARTING AT LEFT, PLACE THE LOUVER ASSEMBLY FROM STEP 22 INTO THE FIRST SET OF LOUVER MOUNT GROOVES AT THE BACK OF THE UNIT.
- PLACE THE ASSEMBLY DOWN IN THE CORRESPONDING GROOVES IN THE FRONT.

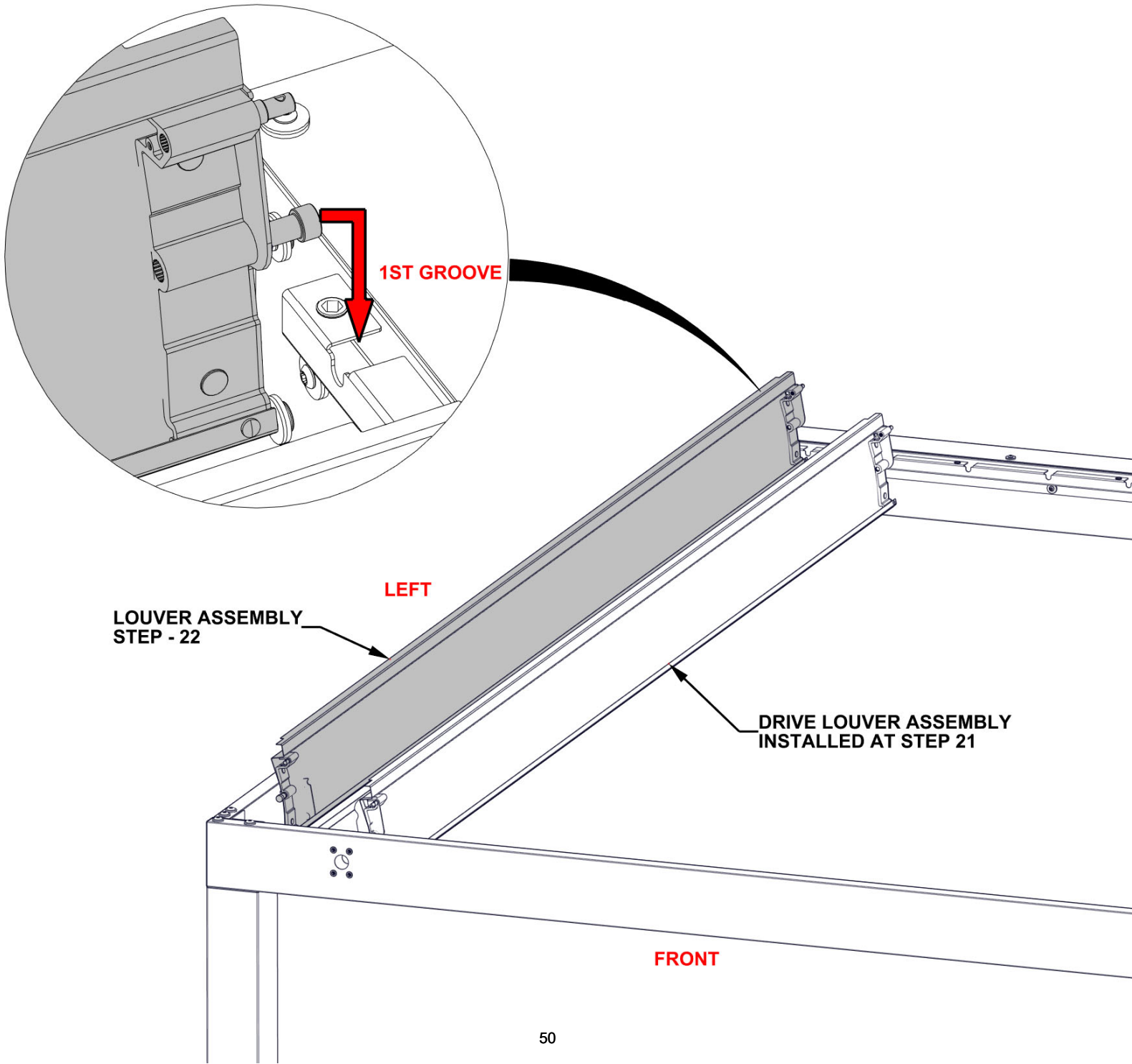

STEP 23B - LOUVER INSTALLATION

Qty	PartNo	Description
1	H101202	TORX PAN HEAD 1/4-20x3/4 ASSY

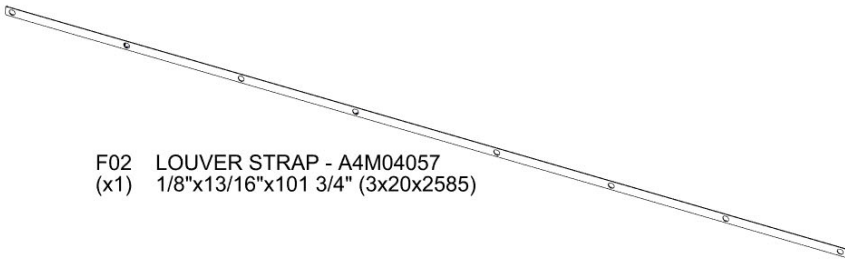

F02 LOUVER STRAP - A4M04057
(x1) 1/8"x13/16"x101 3/4" (3x20x2585)

F01 FLAT BAR - A4M04056
(x1) 1/16"x1"x99 9/16" (2x25x2528)

- ON THE BACK SIDE, INSTALL FLAT BAR AND INSTALL ONE BOLT TO HOLD IN PLACE.
- ATTACH LOUVER TIE STRAP AND SLIDE OVER PINS ON LOUVER ASSEMBLIES

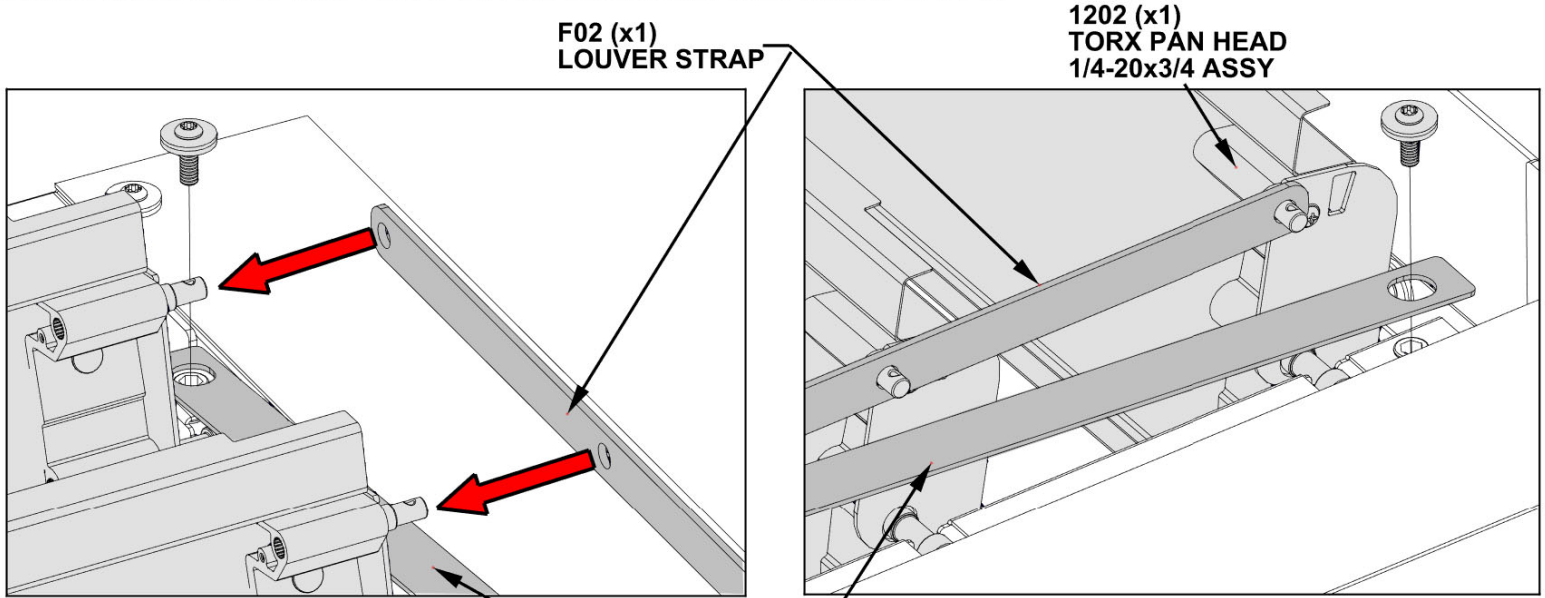

F02 (x1)
LOUVER STRAP

1202 (x1)
TORX PAN HEAD
1/4-20x3/4 ASSY

F01 (x1)
FLAT BAR

VIEW FROM WALL

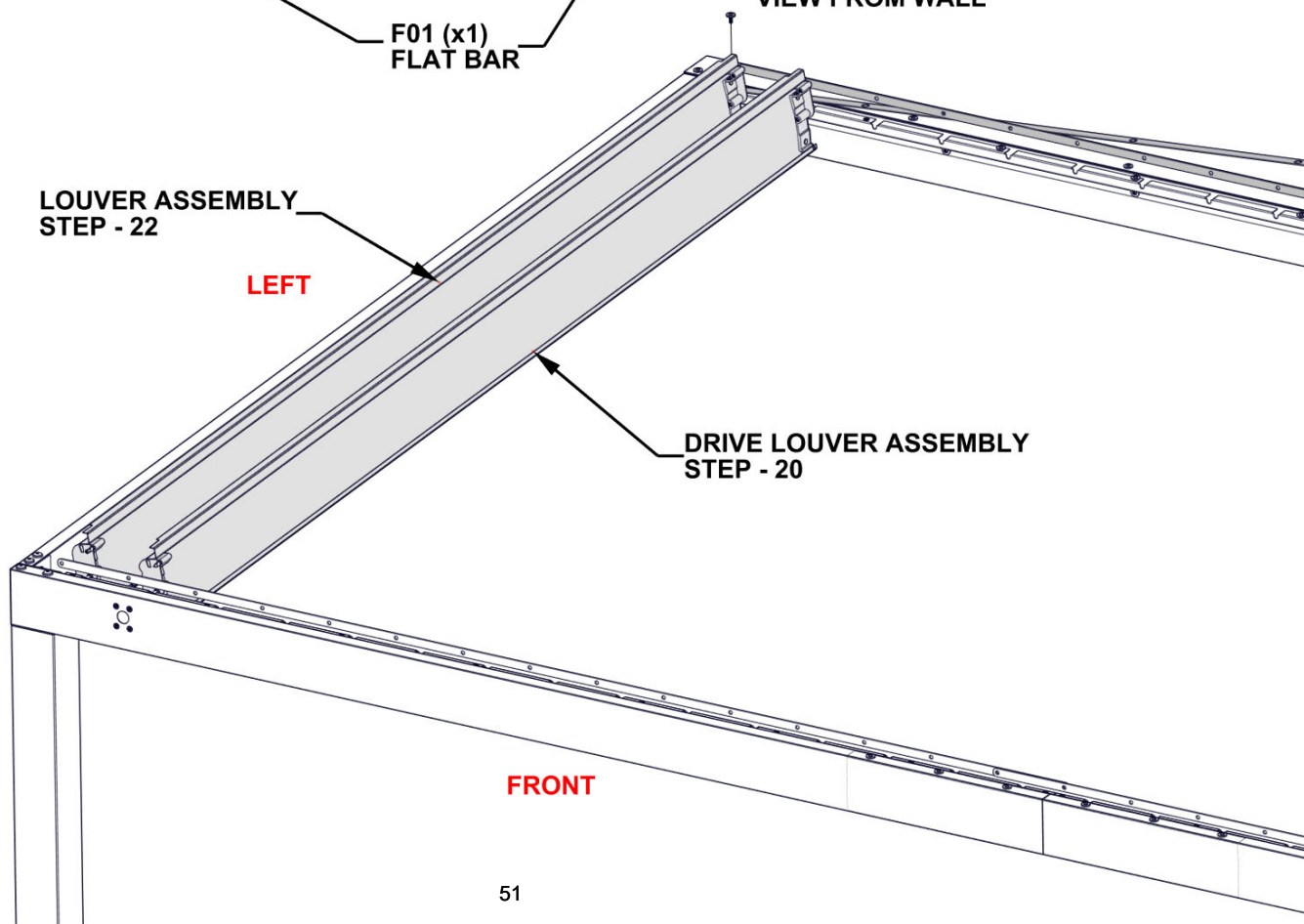

LOUVER ASSEMBLY
STEP - 22

LEFT

DRIVE LOUVER ASSEMBLY
STEP - 20

FRONT

STEP 23C - LOUVER INSTALLATION

Qty	PartNo	Description
1	H101202	TORX PAN HEAD 1/4-20x3/4 ASSY



H101161 COTTER PIN
(x4)

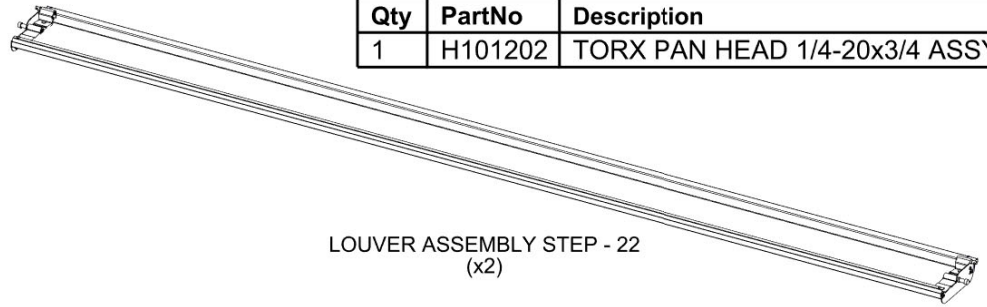

LOUVER ASSEMBLY STEP - 22
(x2)

- ON THE BACK SIDE, LIFT TIE STRAP AND FLAT BAR UP ENOUGH TO SLIDE LOUVERS INTO GROOVES IN LOUVER MOUNTS.
- SLIDE TIE STRAP ONTO PINS ON LOUVER ASSEMBLIES.
- SET LOUVER ASSEMBLIES IN CORRESPONDING HOLES IN FRONT OF UNIT.
- **MAKE SURE ALL LOUVER BLADE ASSEMBLIES ARE ORIENTED IN THE SAME DIRECTION.**
- ATTACH COTTER PINS TO EACH OF THE INSTALLED LOUVER BLADES ON THE BACK SIDE.

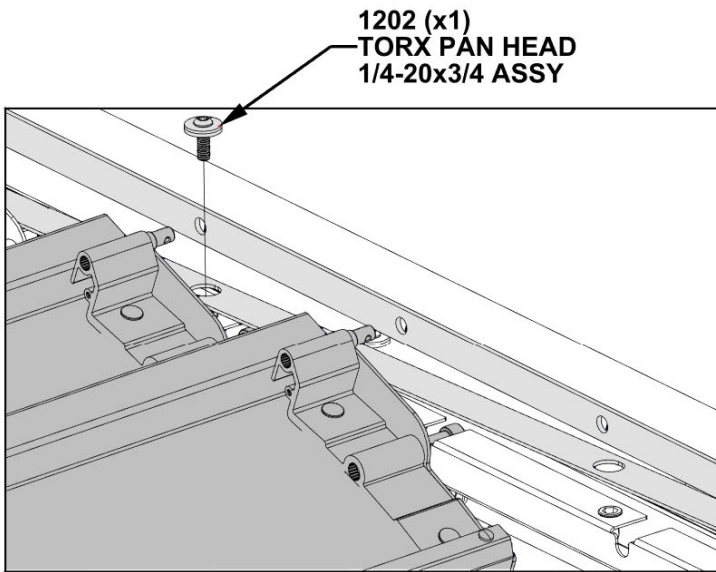

1202 (x1)
TORX PAN HEAD
1/4-20x3/4 ASSY

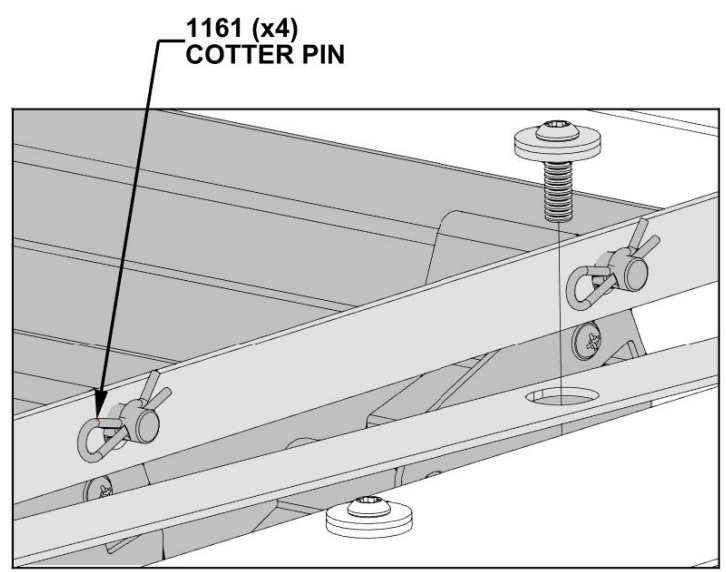

1161 (x4)
COTTER PIN

VIEW FROM WALL

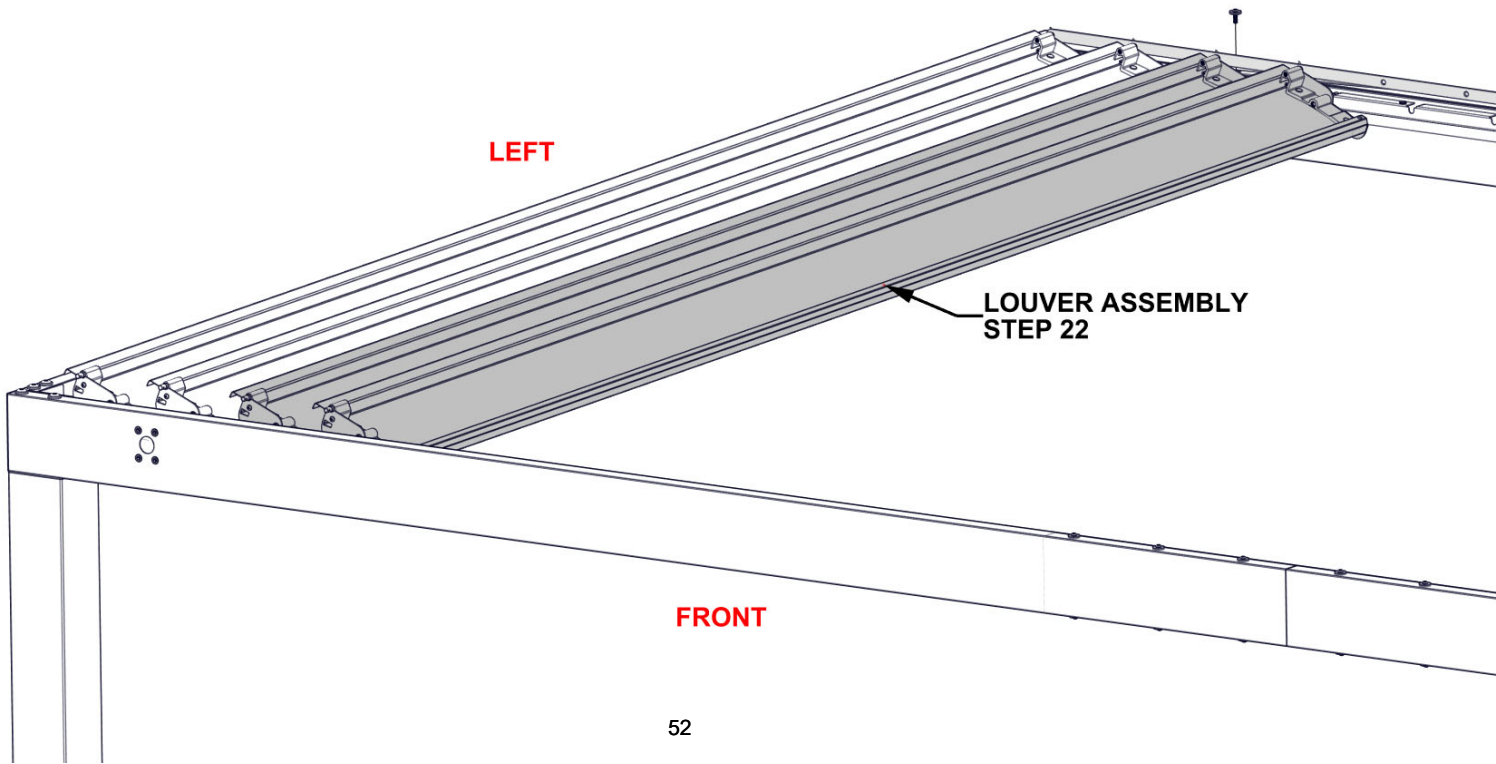

LEFT

LOUVER ASSEMBLY
STEP 22

FRONT

STEP 23D - LOUVER INSTALLATION

Qty	PartNo	Description
2	H101202	TORX PAN HEAD 1/4-20x3/4 ASSY

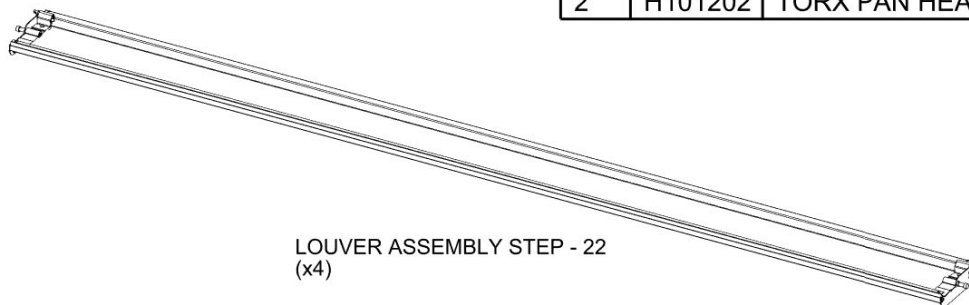

- ON THE BACK SIDE, LIFT TIE STRAP AND FLAT BAR UP ENOUGH TO SLIDE LOUVERS INTO GROOVES IN LOUVER MOUNTS.
- SLIDE TIE STRAP ONTO PINS ON LOUVER ASSEMBLIES.
- SET LOUVER ASSEMBLIES IN CORRESPONDING HOLES IN FRONT OF UNIT.
- **MAKE SURE ALL LOUVER BLADE ASSEMBLIES ARE ORIENTED IN THE SAME DIRECTION.**
- ATTACH FLAT BAR WITH TWO BOLTS.

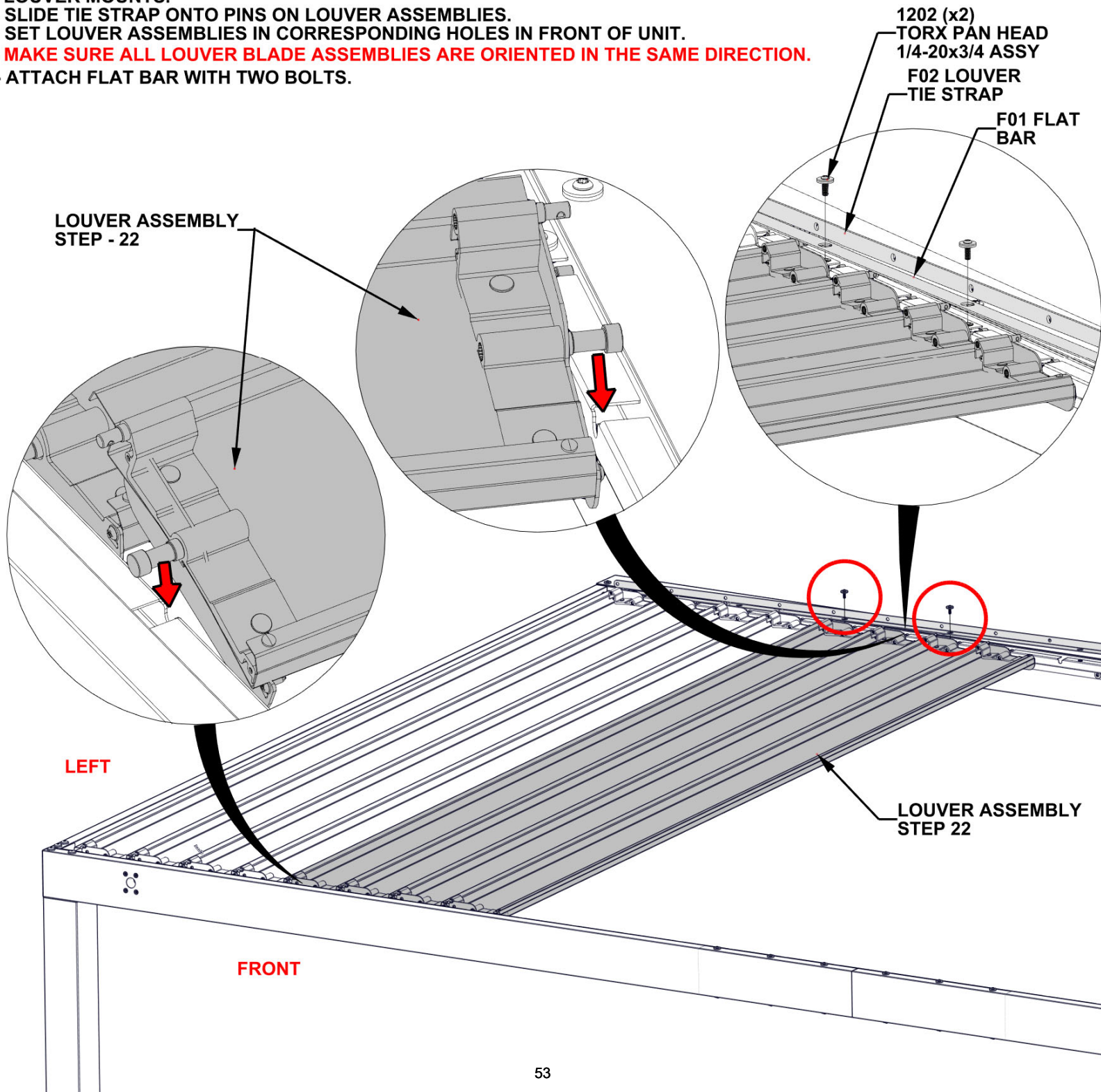

STEP 23E - LOUVER INSTALLATION



H101161 COTTER PIN
(x4)

- MAKE SURE ALL LOUVER BLADE ASSEMBLIES ARE ORIENTED IN THE SAME DIRECTION.
- ATTACH COTTER PINS TO EACH OF THE INSTALLED LOUVER BLADES ON THE BACK SIDE.

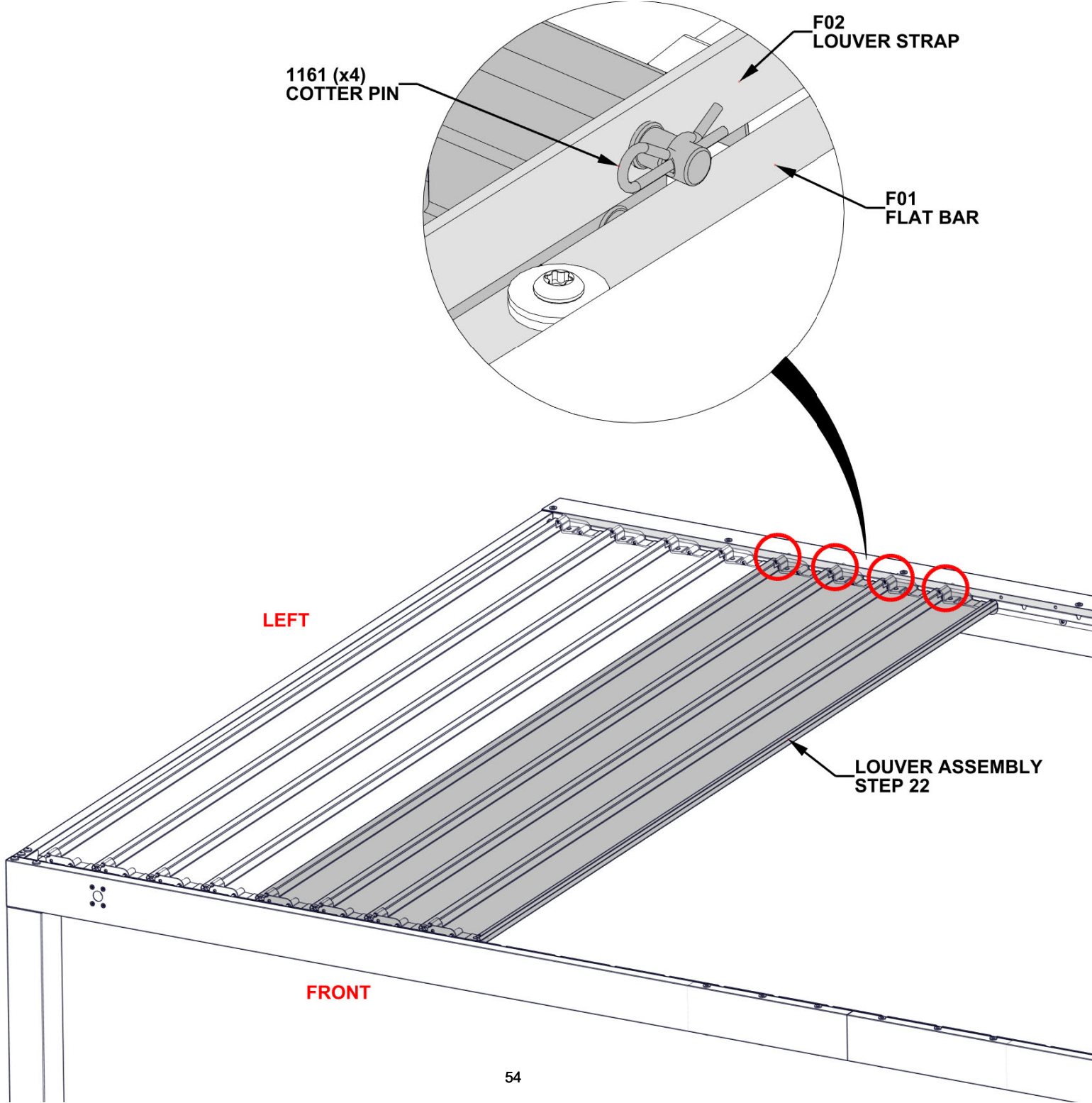

STEP 23F - LOUVER INSTALLATION

Qty	PartNo	Description
2	H101202	TORX PAN HEAD 1/4-20x3/4 ASSY

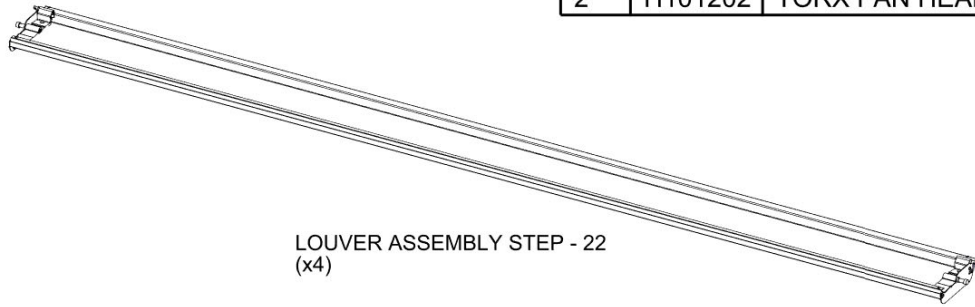

- LIFT TIE STRAP AND FLAT BAR UP ENOUGH TO SLIDE LOUVERS INTO GROOVES IN LOUVER MOUNTS.
- SLIDE TIE STRAP ONTO PINS ON LOUVER ASSEMBLIES.
- SET LOUVER ASSEMBLIES IN CORRESPONDING HOLES IN FRONT OF UNIT.
- **MAKE SURE ALL LOUVER BLADE ASSEMBLIES ARE ORIENTED IN THE SAME DIRECTION.**
- ATTACH FLAT BAR WITH TWO BOLTS.

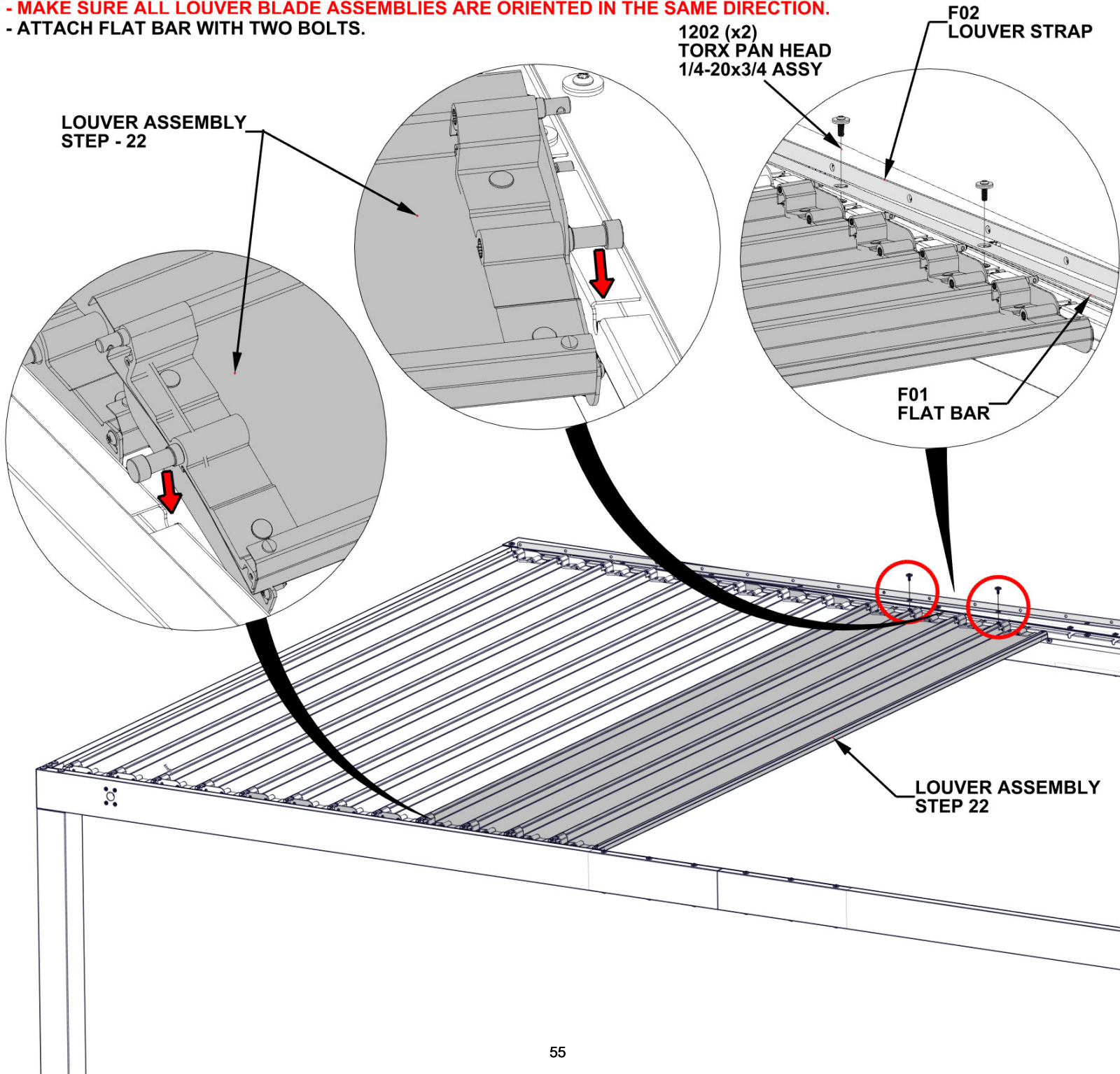

STEP 23G - LOUVER INSTALLATION



H101161 COTTER PIN
(x4)

- MAKE SURE ALL LOUVER BLADE ASSEMBLIES ARE ORIENTED IN THE SAME DIRECTION.
- ATTACH COTTER PINS TO EACH OF THE INSTALLED LOUVER BLADES ON THE BACK SIDE.

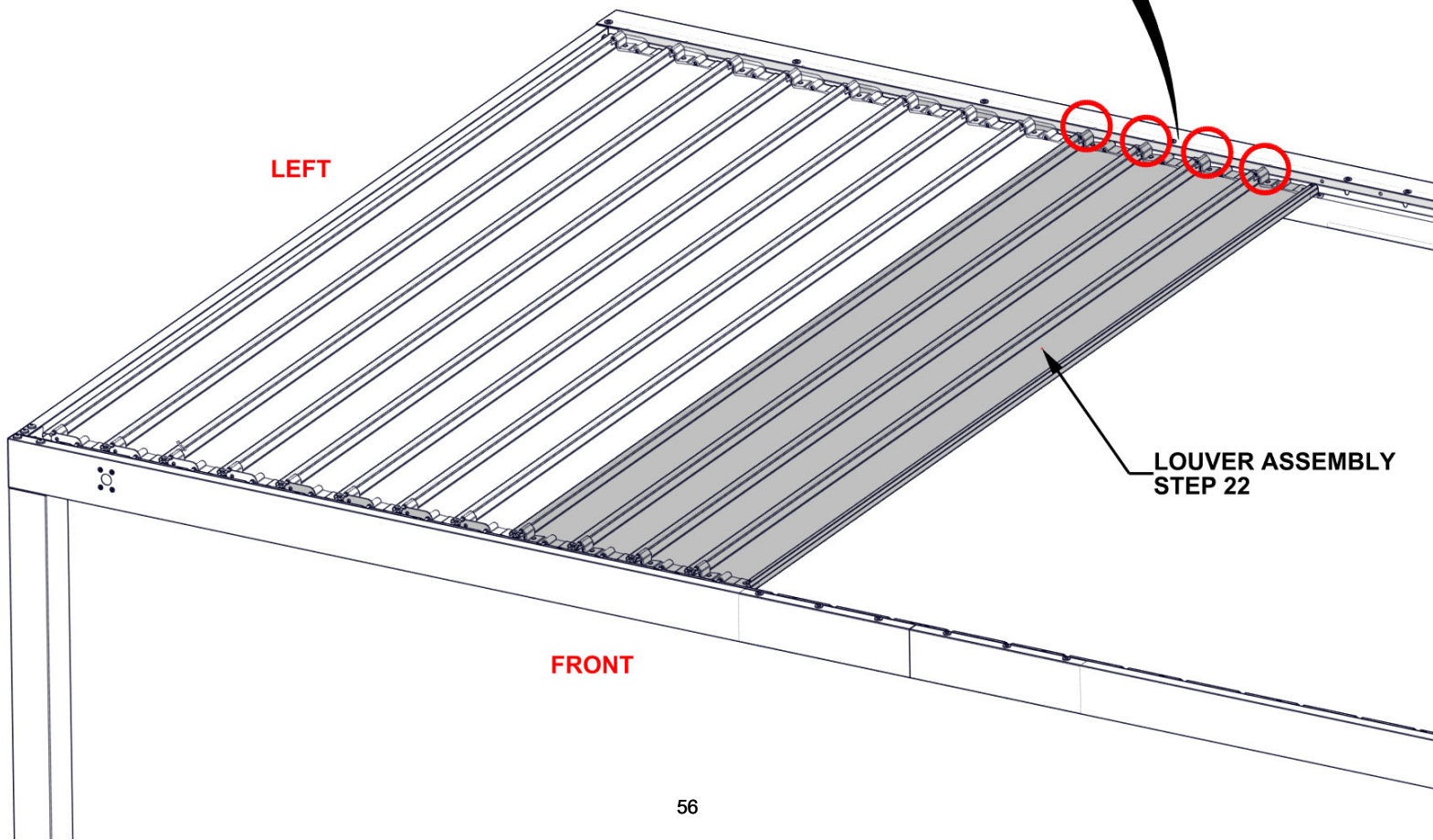
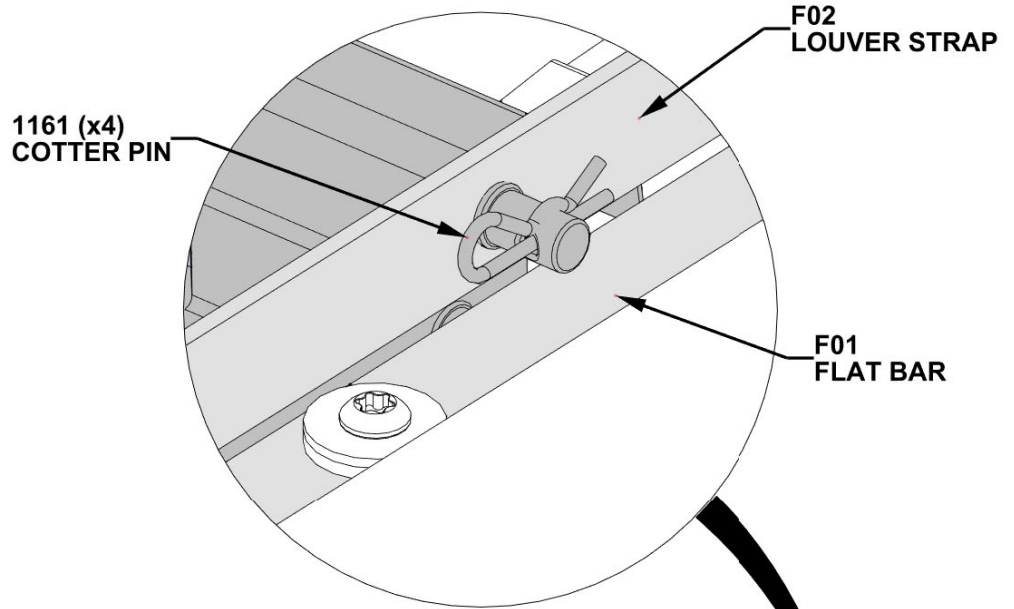

STEP 23H - LOUVER INSTALLATION

Qty	PartNo	Description
2	H101202	TORX PAN HEAD 1/4-20x3/4 ASSY

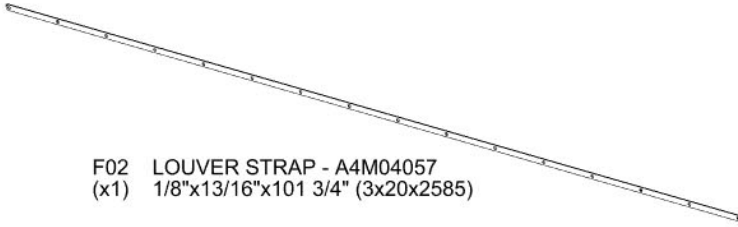

- LIFT TIE STRAP AND FLAT BAR UP ENOUGH TO SLIDE LOUVERS INTO GROOVES IN LOUVER MOUNTS.
- SLIDE TIE STRAP ONTO PINS ON LOUVER ASSEMBLIES.
- SET LOUVER ASSEMBLIES IN CORRESPONDING HOLES IN FRONT OF UNIT.
- **MAKE SURE ALL LOUVER BLADE ASSEMBLIES ARE ORIENTED IN THE SAME DIRECTION.**
- ATTACH FLAT BAR WITH TWO BOLTS.

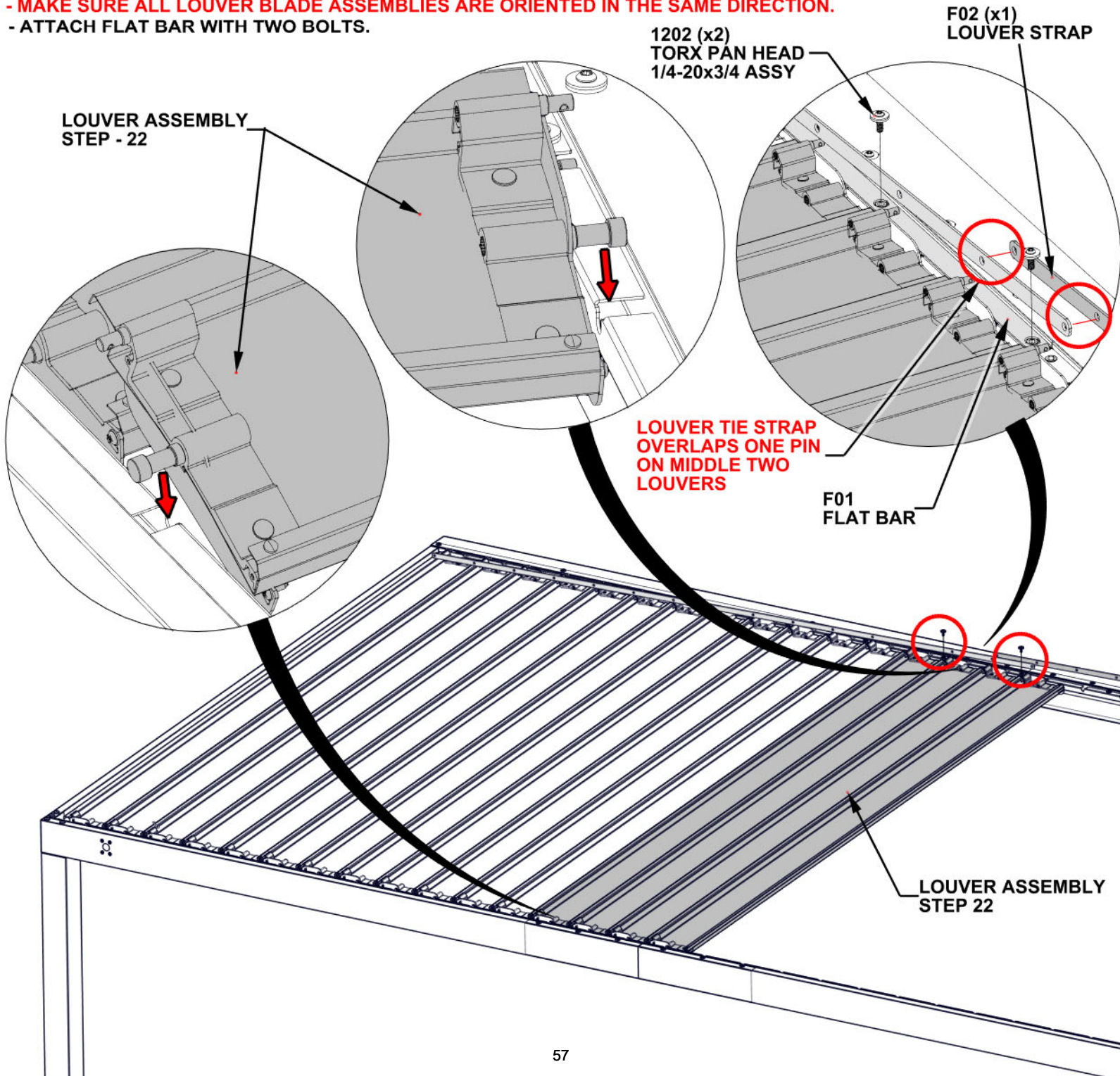

STEP 23I - LOUVER INSTALLATION



H101161 COTTER PIN
(x4)

- MAKE SURE ALL LOUVER BLADE ASSEMBLIES ARE ORIENTED IN THE SAME DIRECTION.
- ATTACH COTTER PINS TO EACH OF THE INSTALLED LOUVER BLADES ON THE BACK SIDE.

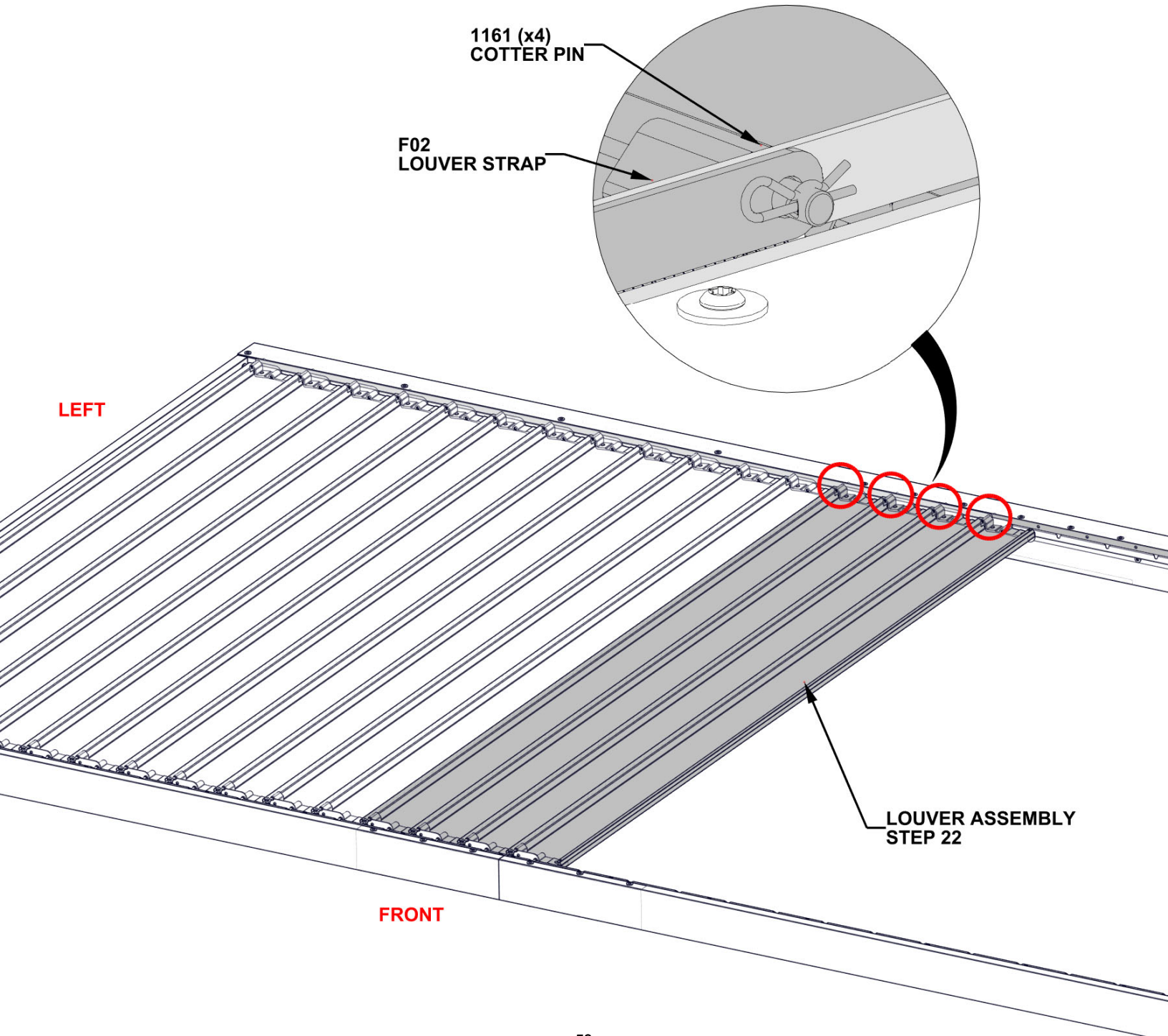

STEP 23J - LOUVER INSTALLATION

Qty	PartNo	Description
3	H101202	TORX PAN HEAD 1/4-20x3/4 ASSY

F01 FLAT BAR - A4M04056
(x1) 1/16"x1"x99 9/16" (2x25x2528)

LOUVER ASSEMBLY STEP - 22
(x4)

- LIFT TIE STRAP AND FLAT BAR UP ENOUGH TO SLIDE LOUVERS INTO GROOVES IN LOUVER MOUNTS.
- SLIDE TIE STRAP ONTO PINS ON LOUVER ASSEMBLIES.
- SET LOUVER ASSEMBLIES IN CORRESPONDING HOLES IN FRONT OF UNIT.
- **MAKE SURE ALL LOUVER BLADE ASSEMBLIES ARE ORIENTED IN THE SAME DIRECTION.**
- ATTACH FLAT BAR WITH THREE BOLTS.

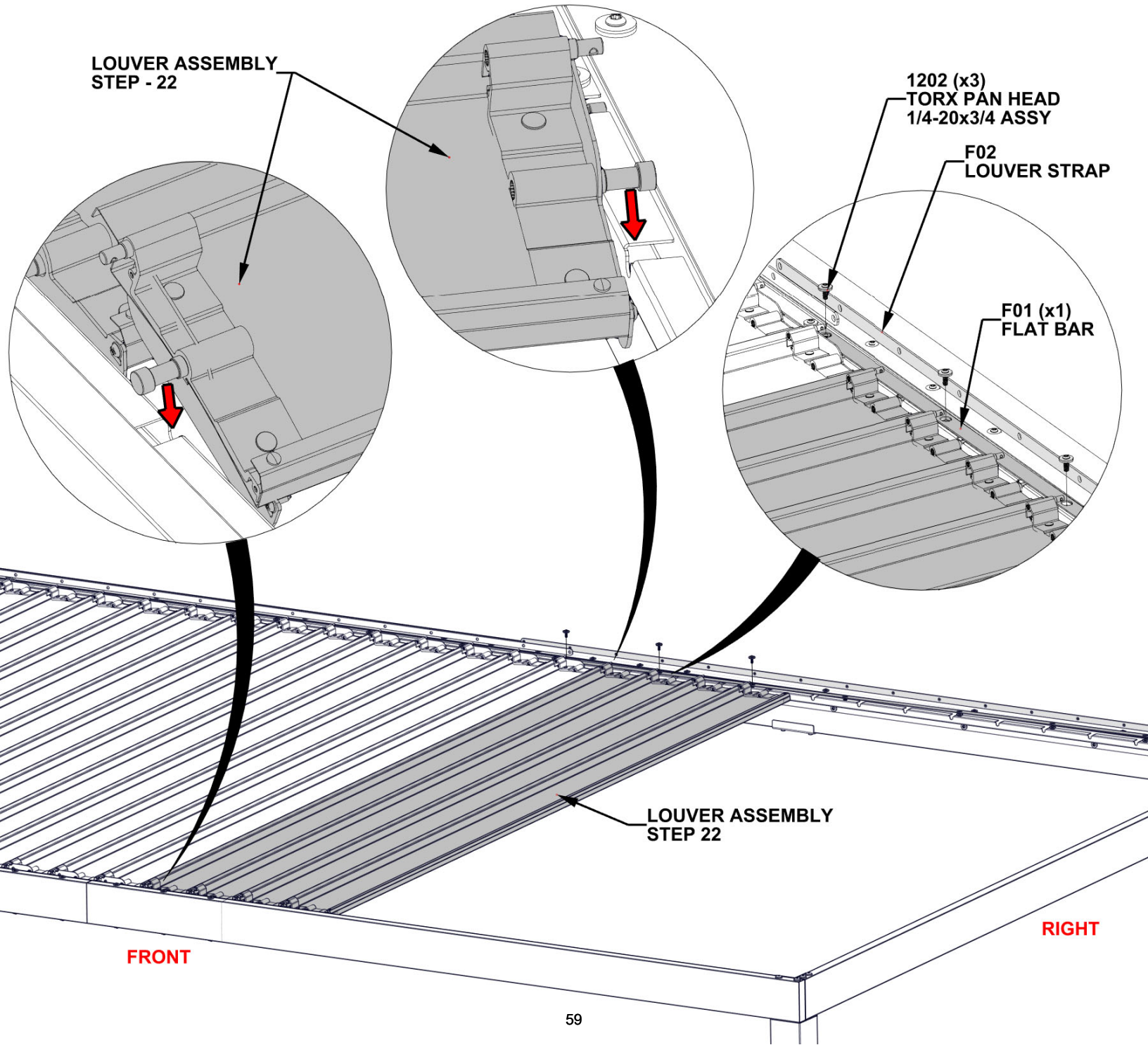

STEP 23K - LOUVER INSTALLATION



H101161 COTTER PIN
(x4)

- MAKE SURE ALL LOUVER BLADE ASSEMBLIES ARE ORIENTED IN THE SAME DIRECTION.
- ATTACH COTTER PINS TO EACH OF THE INSTALLED LOUVER BLADES ON THE BACK SIDE.

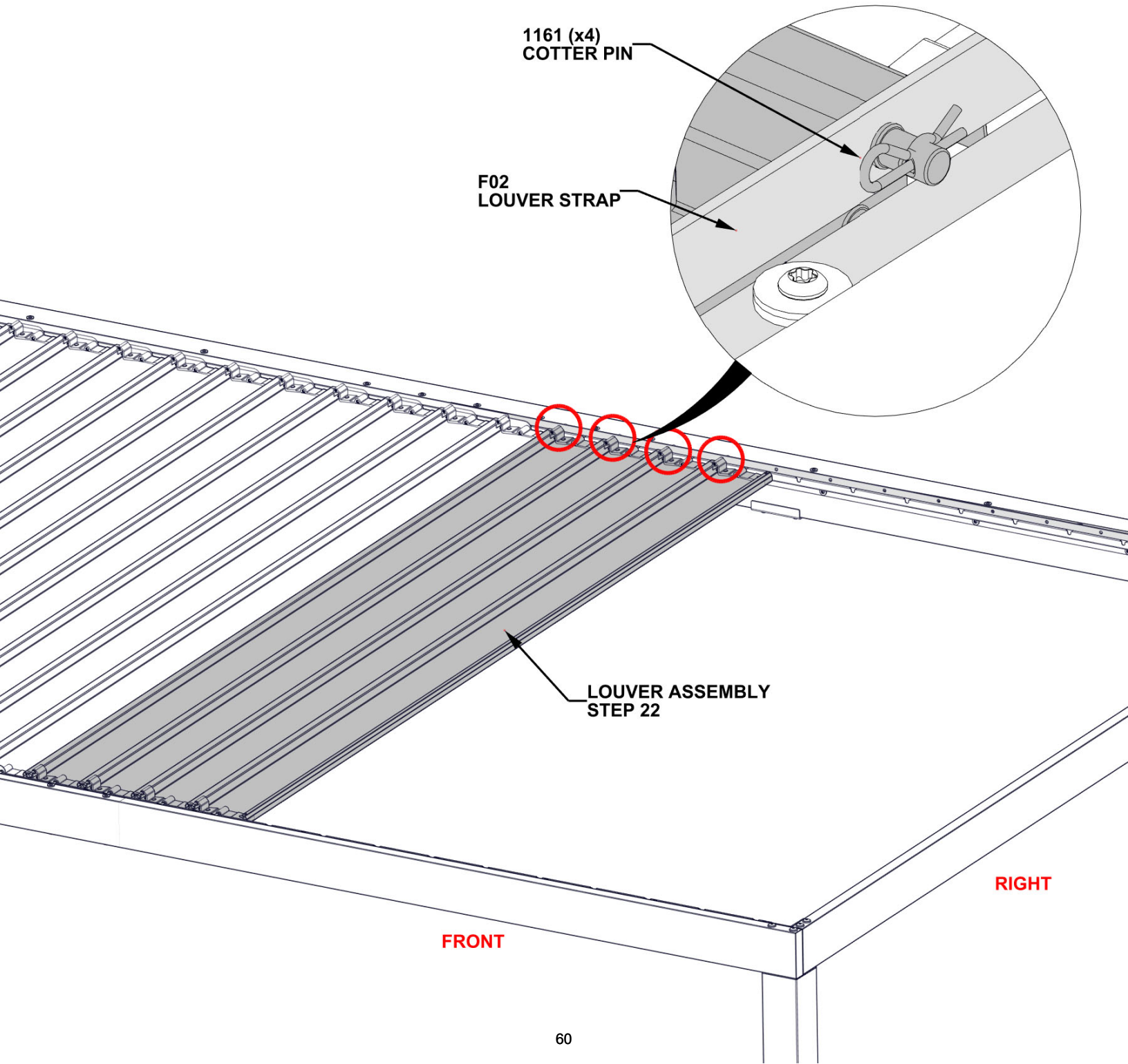

STEP 23L - LOUVER INSTALLATION

Qty	PartNo	Description
2	H101202	TORX PAN HEAD 1/4-20x3/4 ASSY

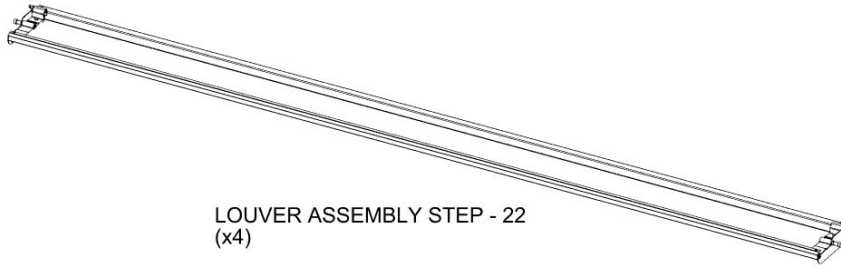

- LIFT TIE STRAP AND FLAT BAR UP ENOUGH TO SLIDE LOUVERS INTO GROOVES IN LOUVER MOUNTS.
- SLIDE TIE STRAP ONTO PINS ON LOUVER ASSEMBLIES.
- SET LOUVER ASSEMBLIES IN CORRESPONDING HOLES IN FRONT OF UNIT.
- **MAKE SURE ALL LOUVER BLADE ASSEMBLIES ARE ORIENTED IN THE SAME DIRECTION.**
- ATTACH FLAT BAR WITH TWO BOLTS.

LOUVER ASSEMBLY
STEP - 22

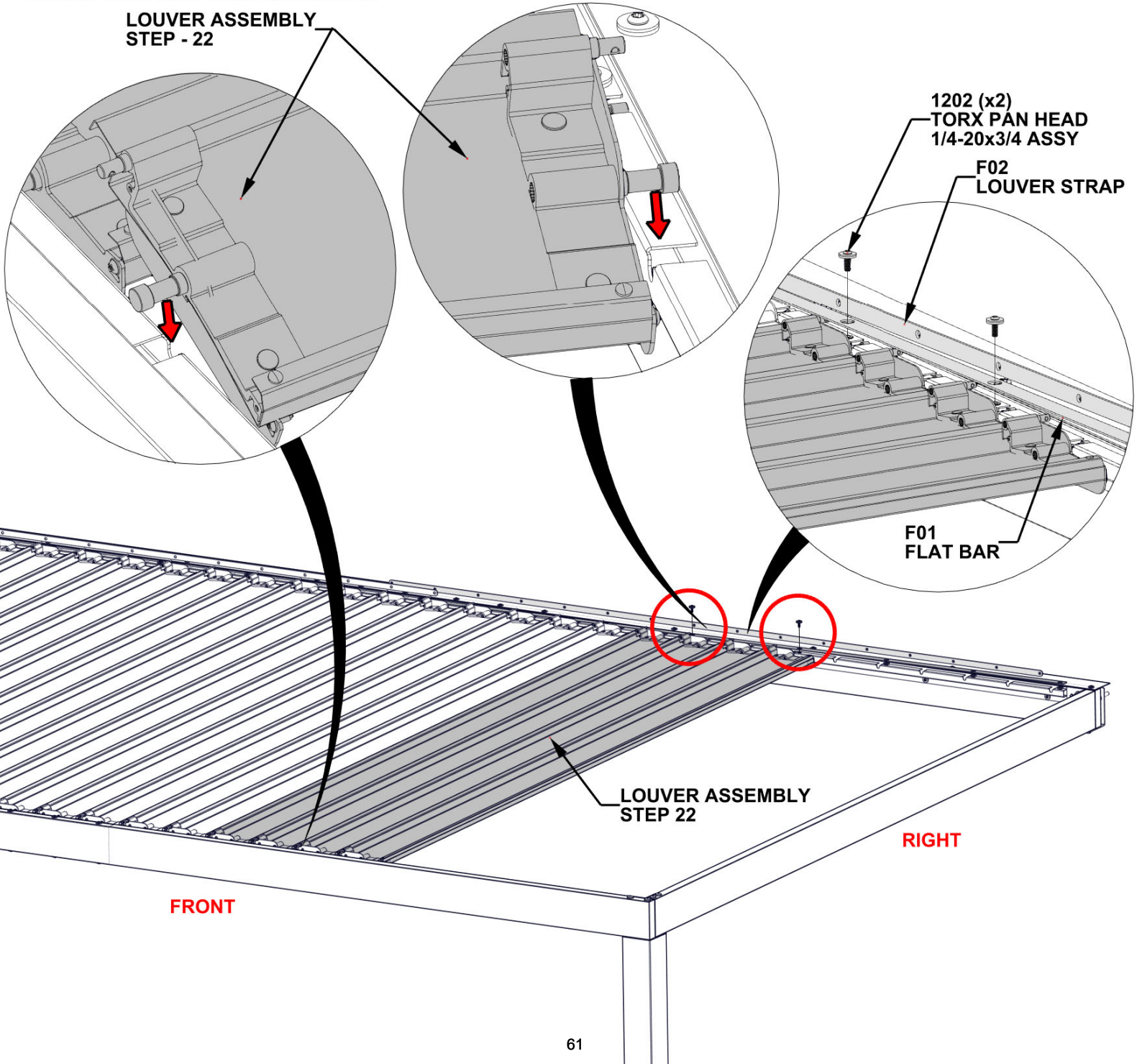

STEP 23M - LOUVER INSTALLATION



H101161 COTTER PIN
(x4)

- MAKE SURE ALL LOUVER BLADE ASSEMBLIES ARE ORIENTED IN THE SAME DIRECTION.
- ATTACH COTTER PINS TO EACH OF THE INSTALLED LOUVER BLADES ON THE BACK SIDE.

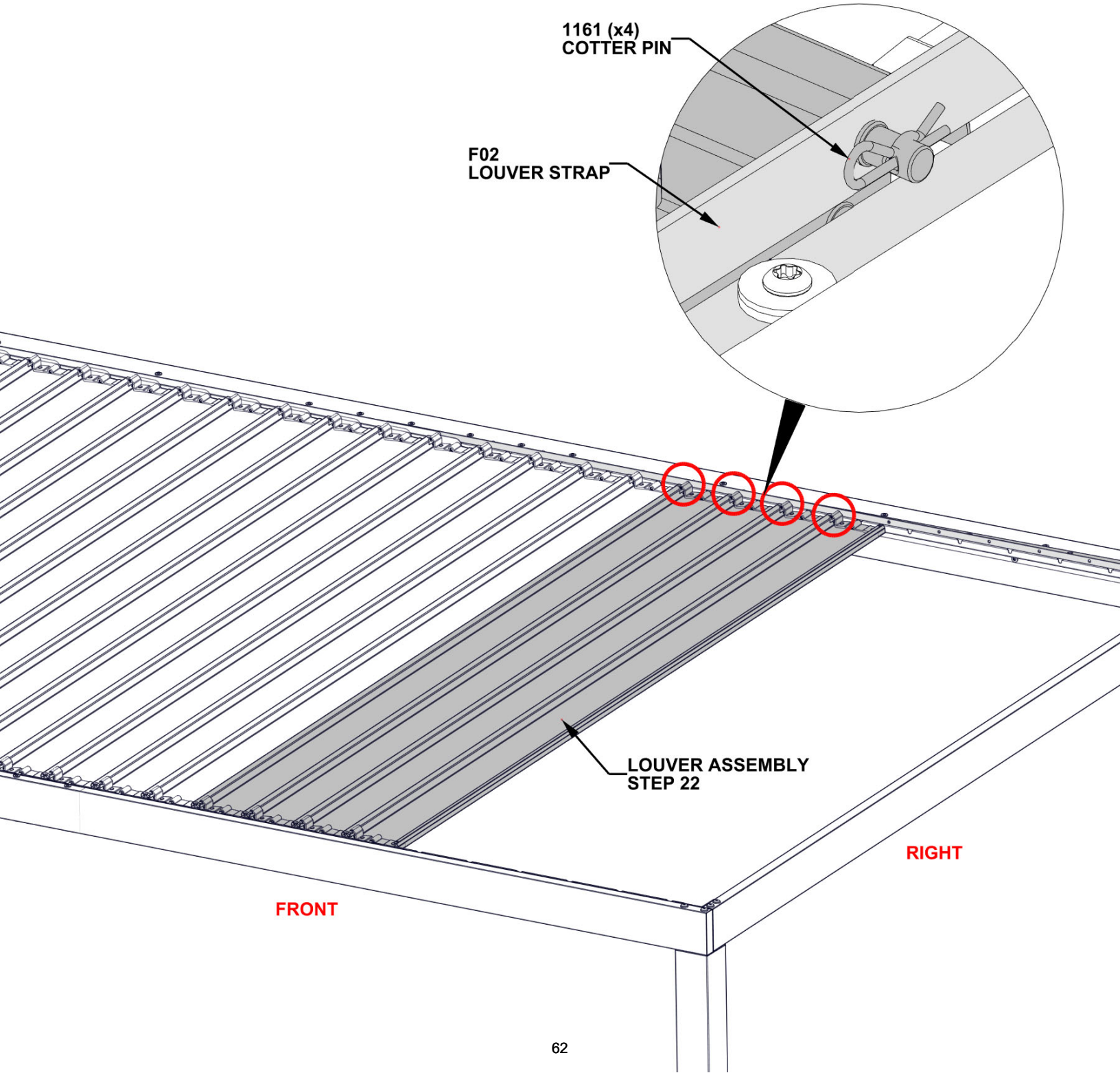

STEP 23N - LOUVER INSTALLATION

Qty	PartNo	Description
2	H101202	TORX PAN HEAD 1/4-20x3/4 ASSY

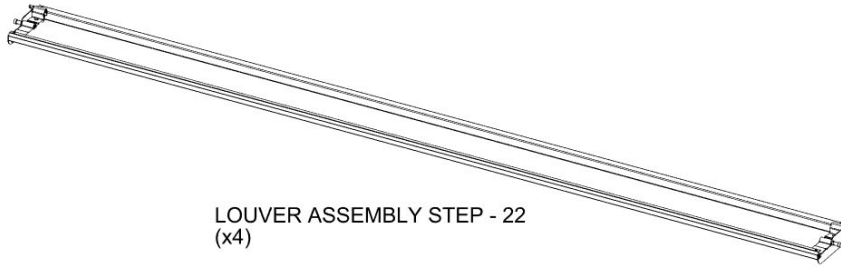

- LIFT TIE STRAP AND FLAT BAR UP ENOUGH TO SLIDE LOUVERS INTO GROOVES IN LOUVER MOUNTS.
- SLIDE TIE STRAP ONTO PINS ON LOUVER ASSEMBLIES.
- SET LOUVER ASSEMBLIES IN CORRESPONDING HOLES IN FRONT OF UNIT.
- **MAKE SURE ALL LOUVER BLADE ASSEMBLIES ARE ORIENTED IN THE SAME DIRECTION.**
- ATTACH FLAT BAR WITH TWO BOLTS.

LOUVER ASSEMBLY
STEP - 22

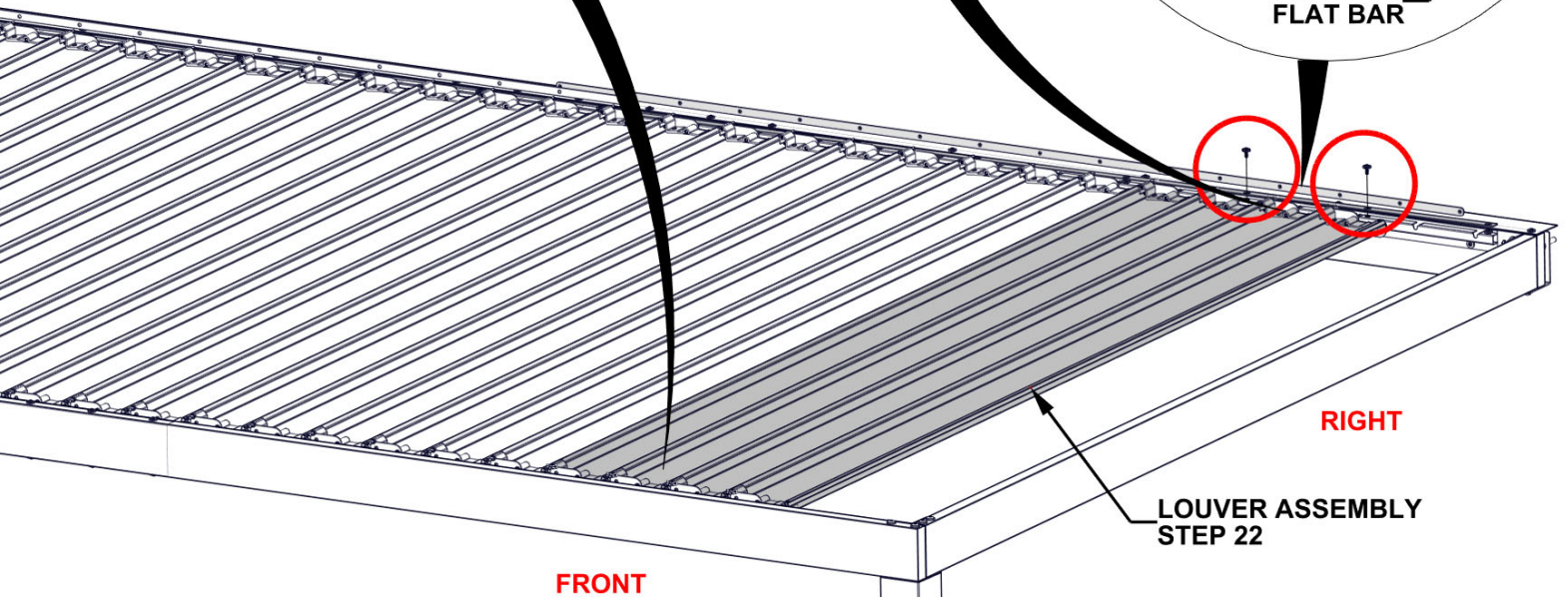
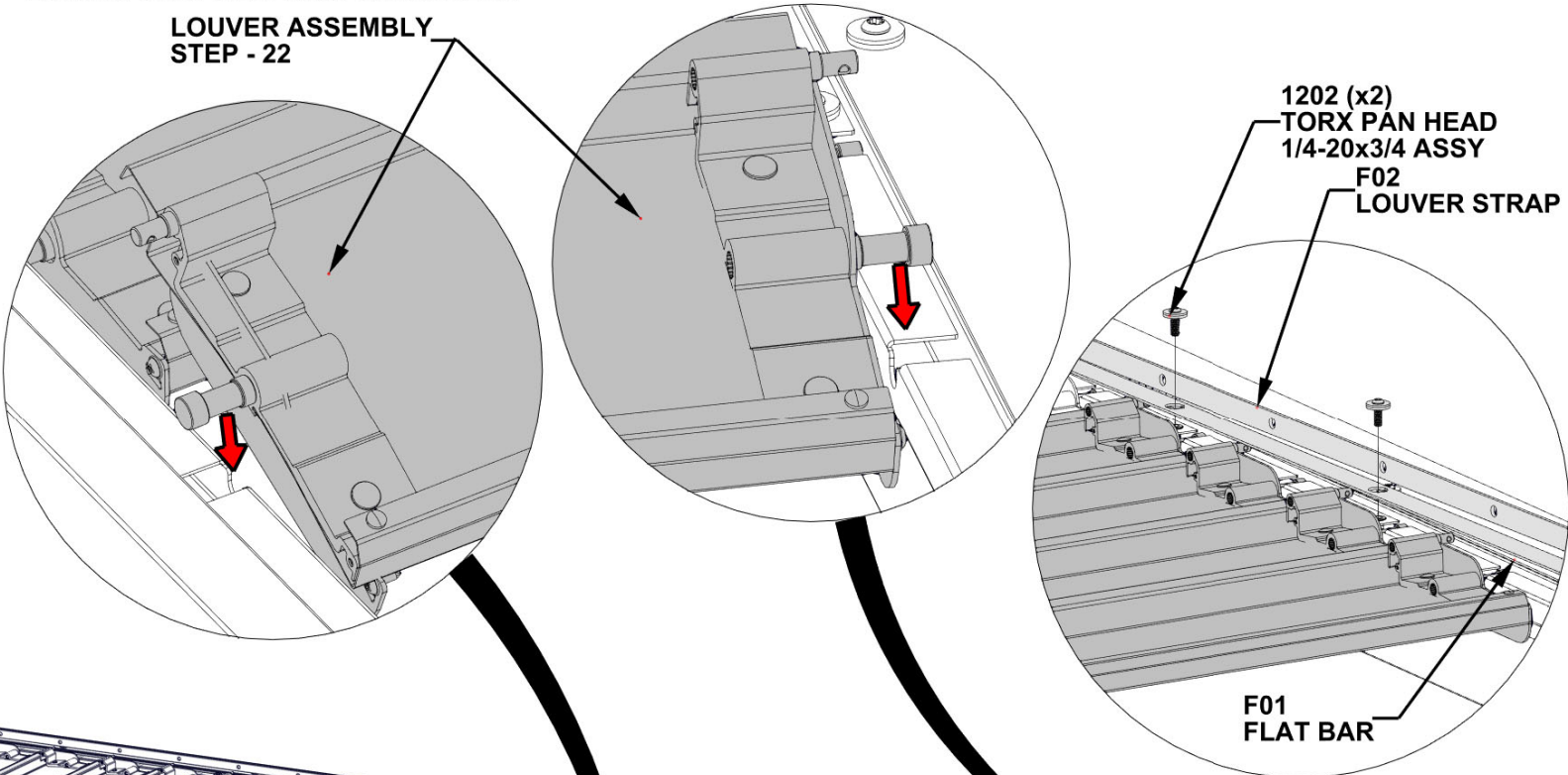

STEP 230 - LOUVER INSTALLATION



H101161 COTTER PIN
(x4)

- MAKE SURE ALL LOUVER BLADE ASSEMBLIES ARE ORIENTED IN THE SAME DIRECTION.
- ATTACH COTTER PINS TO EACH OF THE INSTALLED LOUVER BLADES ON THE BACK SIDE.

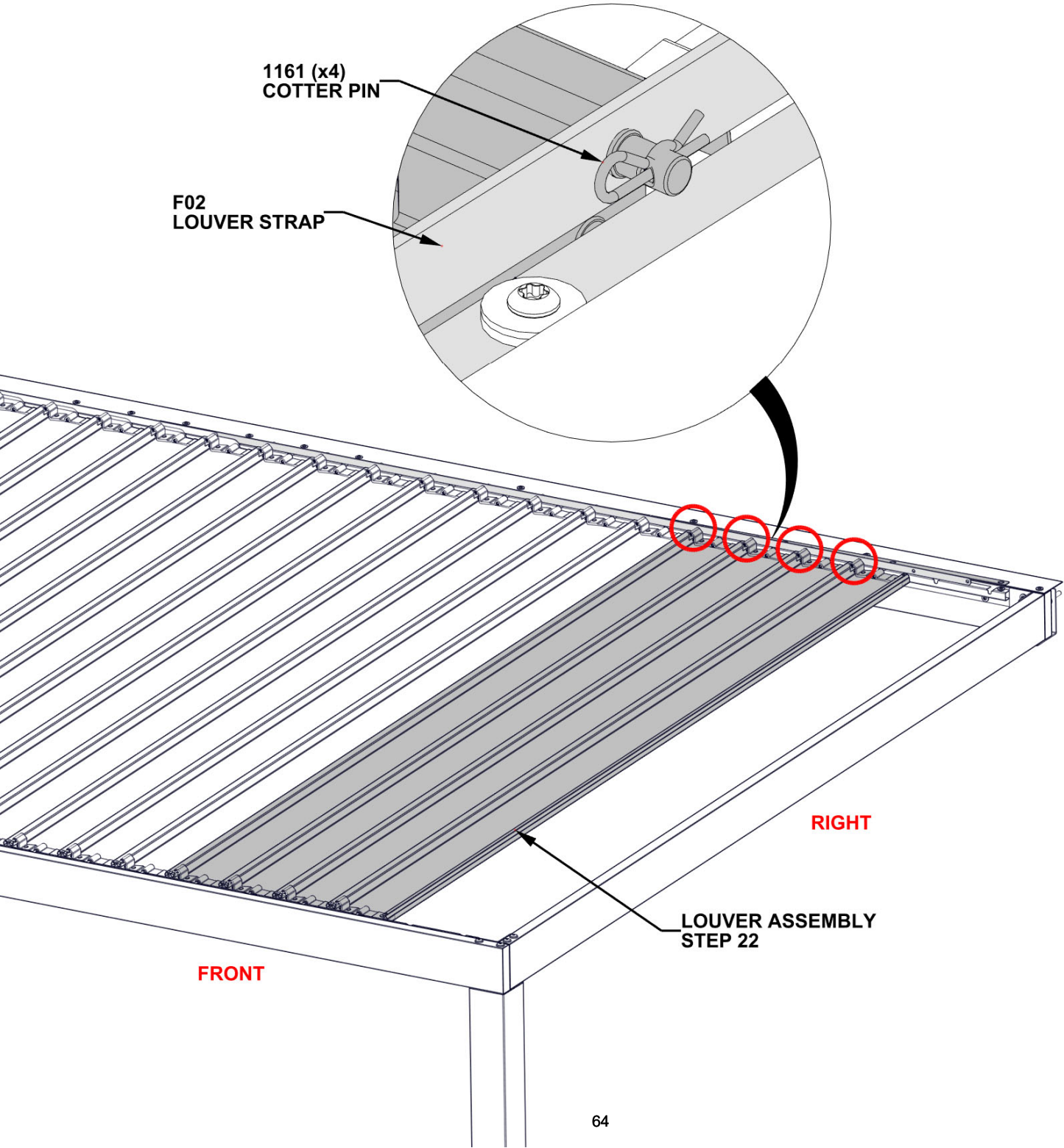

STEP 23P - LOUVER INSTALLATION

Qty	PartNo	Description
1	H101202	TORX PAN HEAD 1/4-20x3/4 ASSY

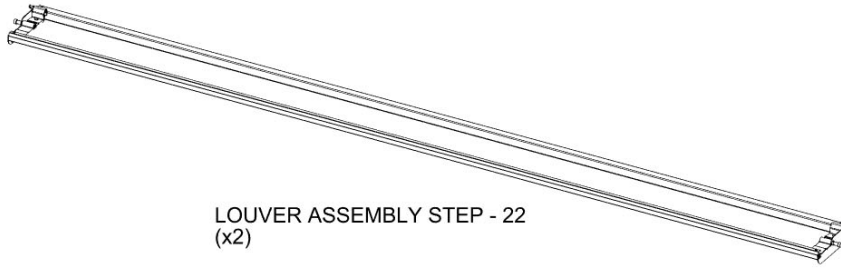

LOUVER ASSEMBLY STEP - 22
(x2)

- LIFT TIE STRAP AND FLAT BAR UP ENOUGH TO SLIDE LOUVERS INTO GROOVES IN LOUVER MOUNTS.
- SLIDE TIE STRAP ONTO PINS ON LOUVER ASSEMBLIES.
- SET LOUVER ASSEMBLIES IN CORRESPONDING HOLES IN FRONT OF UNIT.
- **MAKE SURE ALL LOUVER BLADE ASSEMBLIES ARE ORIENTED IN THE SAME DIRECTION.**
- ATTACH FLAT BAR WITH ONE BOLT.

LOUVER ASSEMBLY
STEP - 22

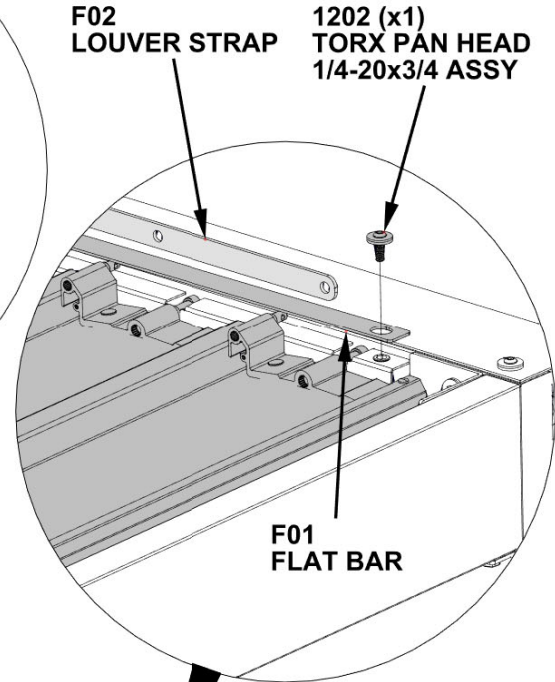
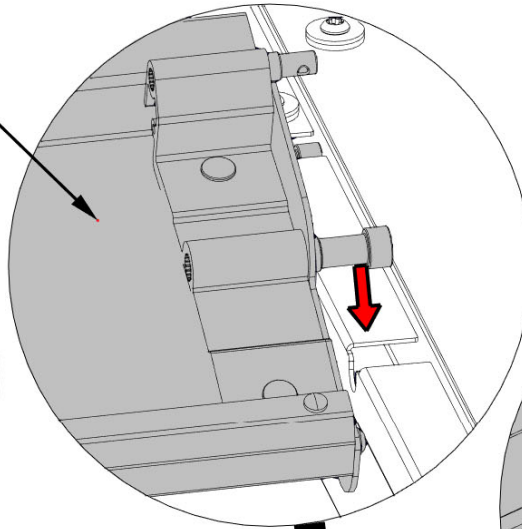
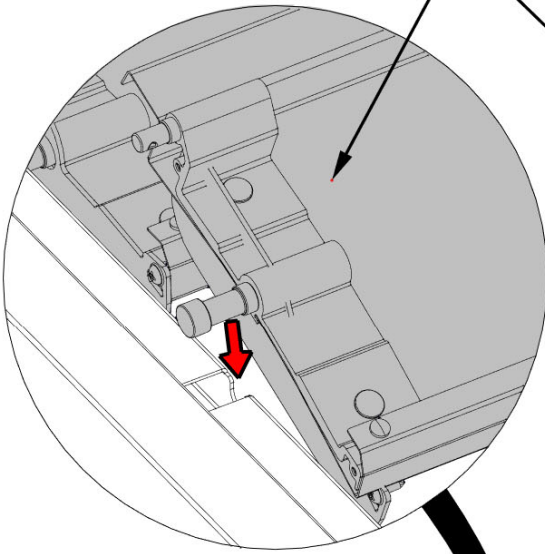

F02
LOUVER STRAP

1202 (x1)
TORX PAN HEAD
1/4-20x3/4 ASSY

F01
FLAT BAR

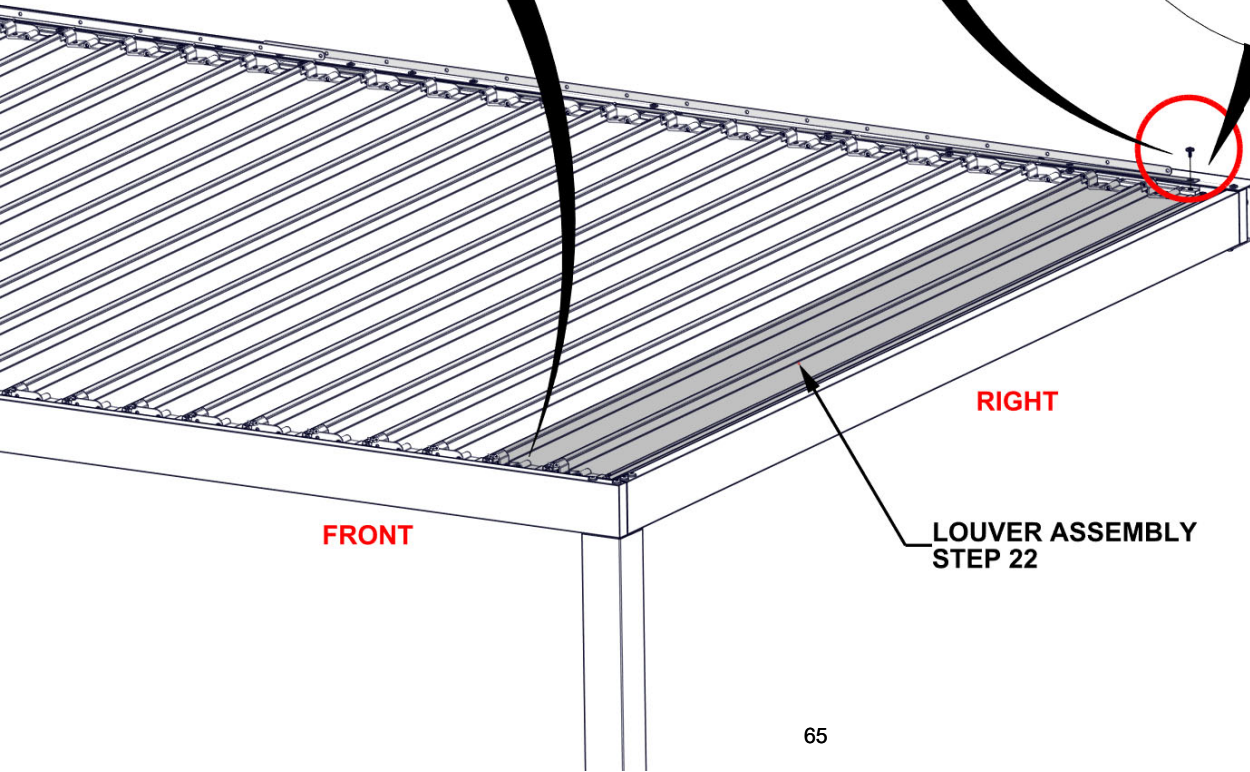

FRONT

RIGHT

LOUVER ASSEMBLY
STEP 22

STEP 23Q - LOUVER INSTALLATION



H101161 COTTER PIN
(x2)

- MAKE SURE ALL LOUVER BLADE ASSEMBLIES ARE ORIENTED IN THE SAME DIRECTION.
- ATTACH COTTER PINS TO EACH OF THE INSTALLED LOUVER BLADES ON THE BACK SIDE.

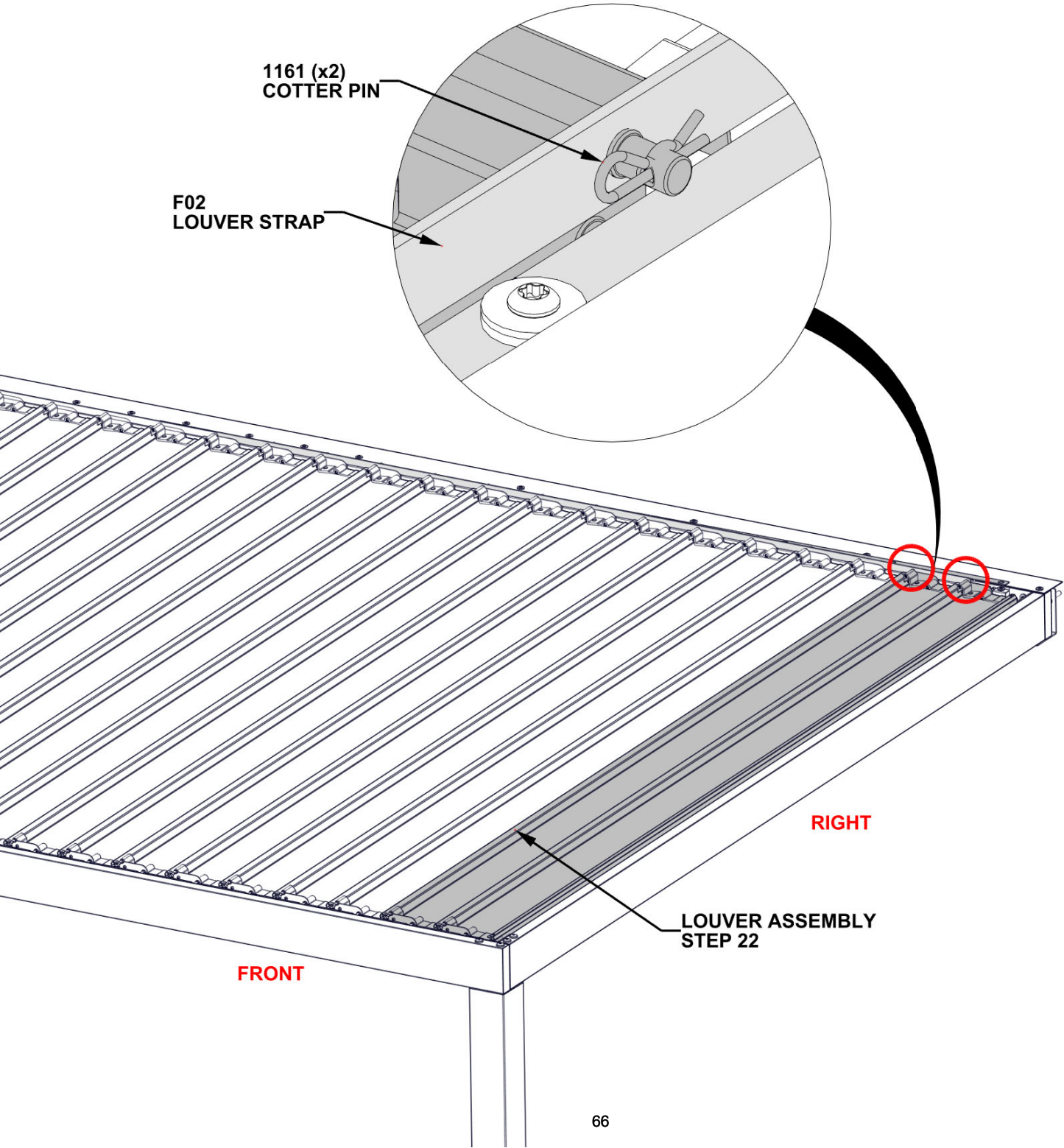

STEP 24 - LOUVER INSTALLATION

Qty	PartNo	Description
16	H101202	TORX PAN HEAD 1/4-20x3/4 ASSY

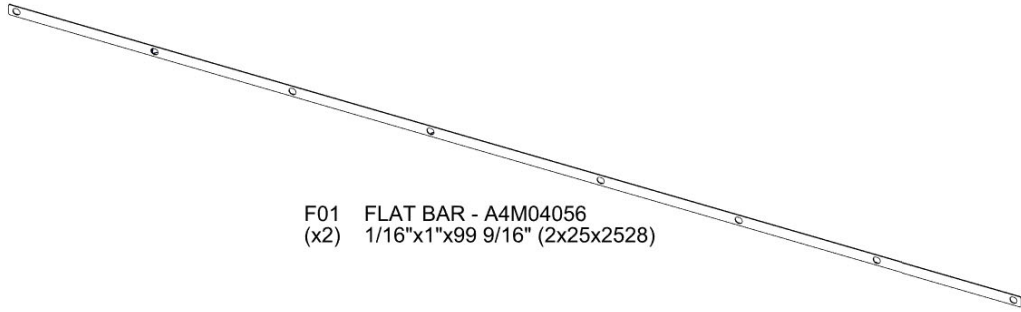

F01 FLAT BAR - A4M04056
(x2) 1/16"x1"x99 9/16" (2x25x2528)

- ON THE FRONT SIDE, ATTACH FLAT BAR ALONG EACH LOUVER MOUNT. FLAT BAR WILL HOLD ALL LOUVERS IN PLACE.

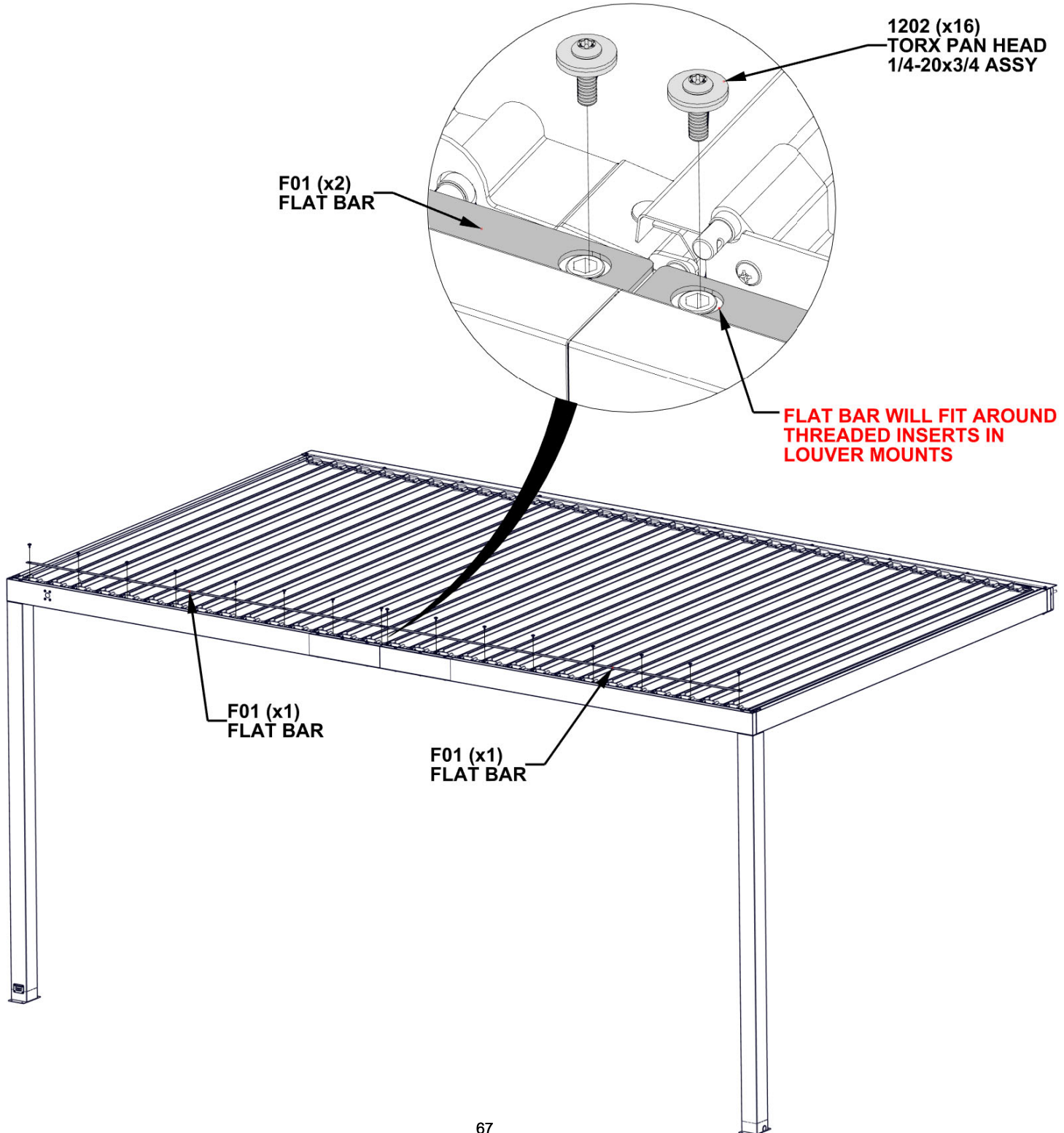

STEP 25A - LOUVER INSTALLATION

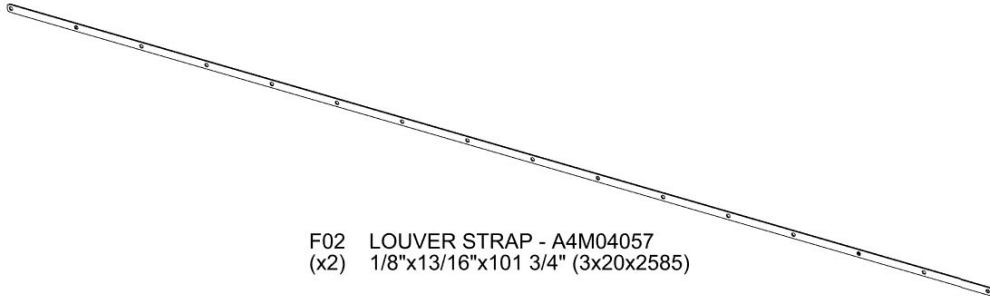

F02 LOUVER STRAP - A4M04057
(x2) 1/8"x13/16"x101 3/4" (3x20x2585)

- LOUVER TIE STRAPS WILL CONNECT ALL LOUVERS TO ONE ANOTHER.
- STARTING ON THE LEFT AND WORKING TO THE RIGHT, CONNECT LOUVERS USING TIE STRAPS. OVERLAP TIE STRAPS TO HOLD MIDDLE LOUVERS TOGETHER.

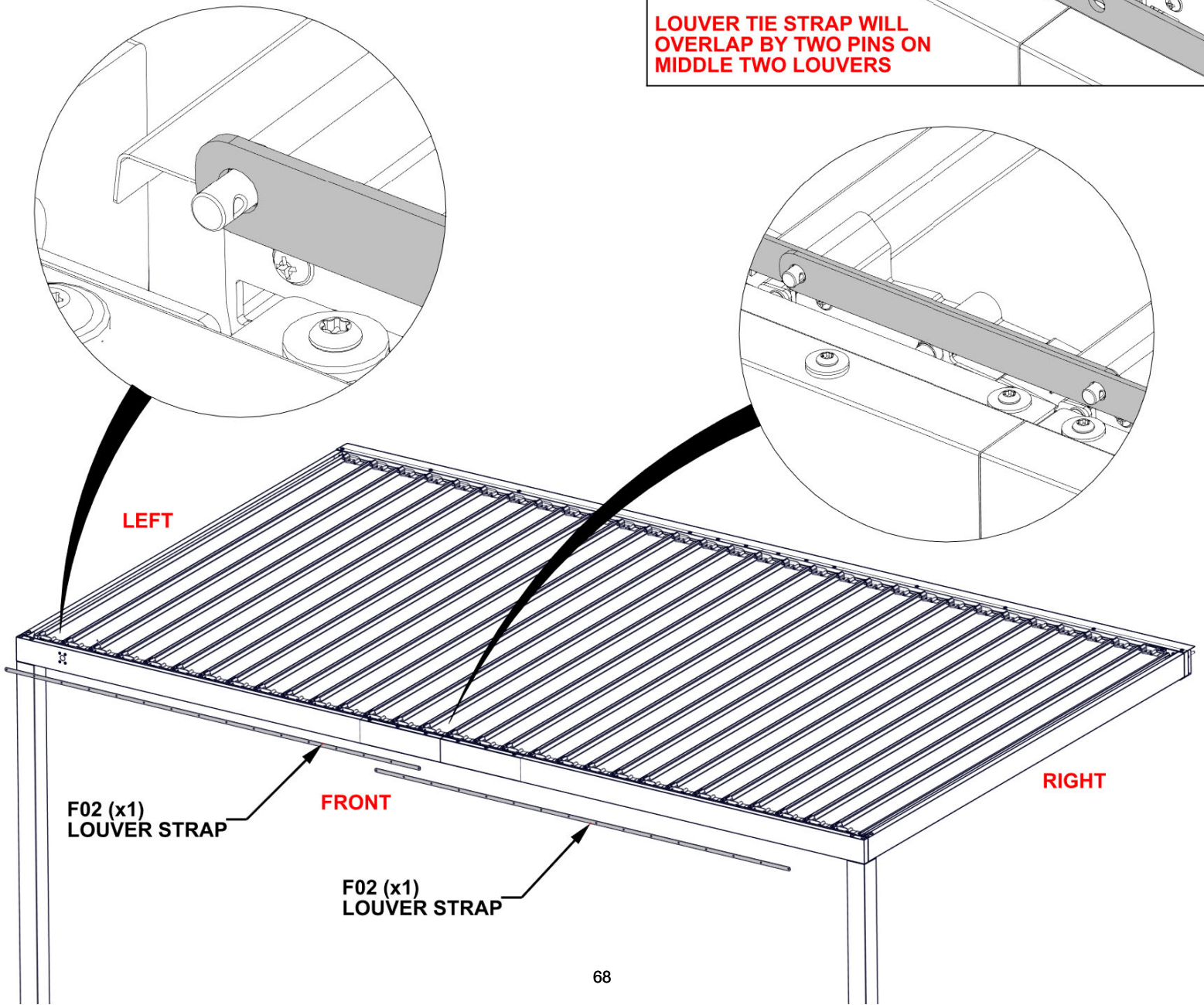
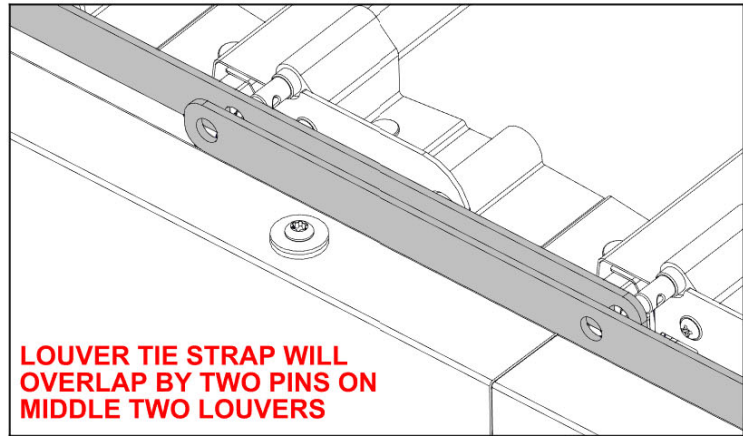

STEP 25B - LOUVER INSTALLATION

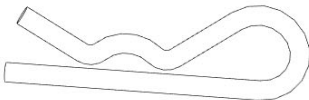

H101161 COTTER PIN
(x30)

- INSTALL COTTER PINS ON EACH LOUVER TO HOLD TIE STRAPS IN PLACE.
- CONFIRM ALL HARDWARE HAS BEEN TIGHTENED FROM PREVIOUS STEPS.

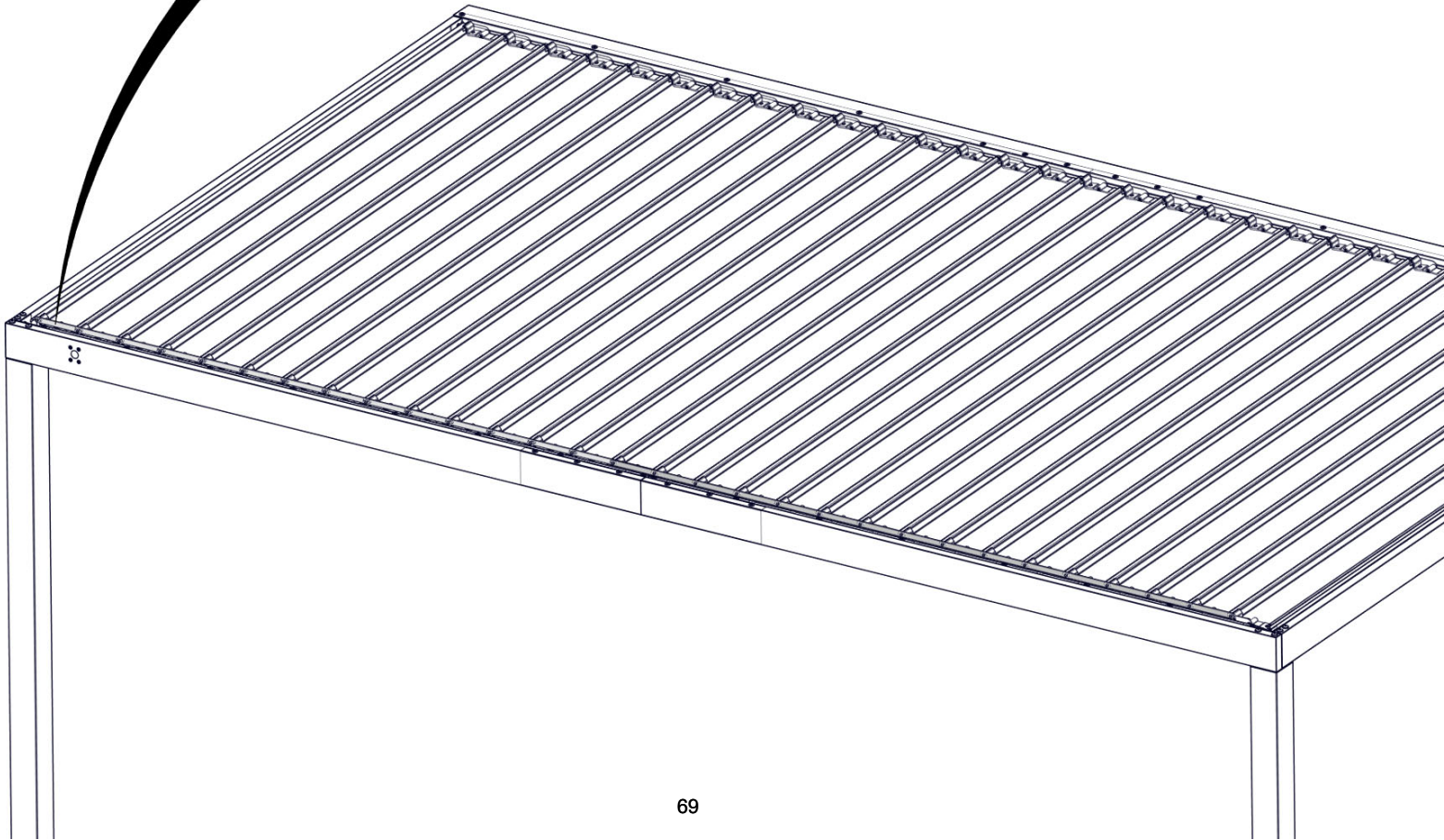
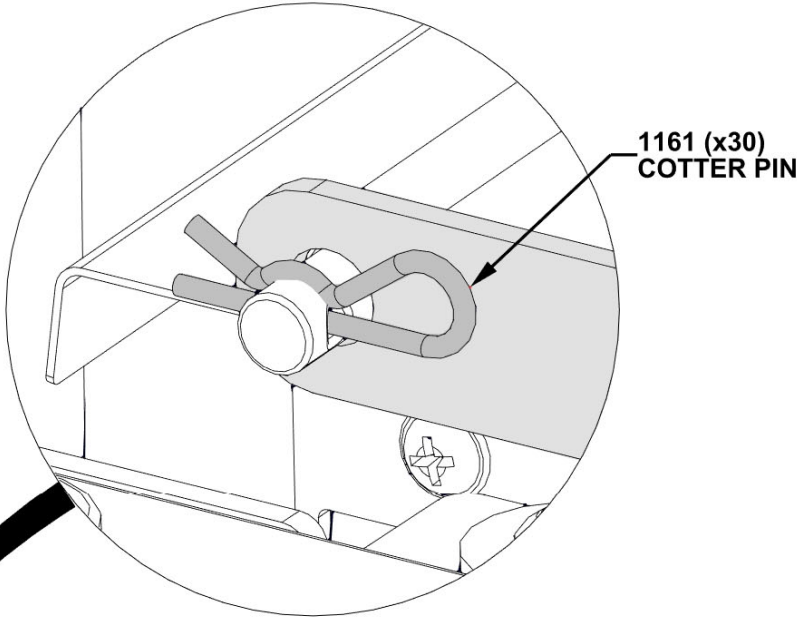

STEP 26 - LOUVER MECHANISM



L04 BODY HALF - A4M02132
(x1) 1 1/16"x2 1/2"x2 7/8" (17x64x73)



F06 SPACER - A4M02227
(x1) 1 1/16"x2 3/16"x2 3/4" (1.5x56x70)

Qty	PartNo	Description
4	H101126	TORX PAN HEAD 1/4-20x2 1/8" BLK

- ALIGN SCREW HOLES.

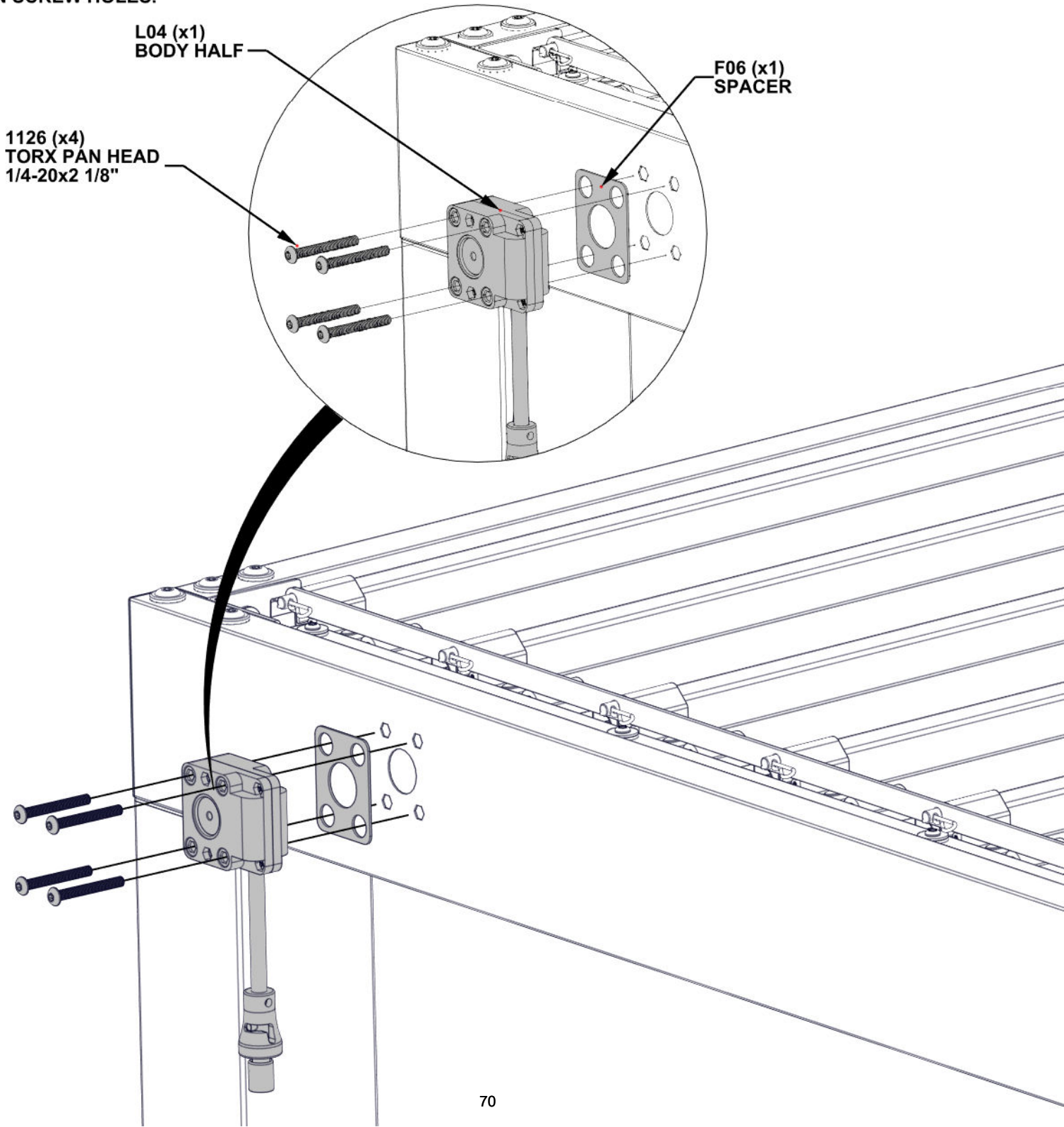

STEP 27 - LOUVER MECHANISM

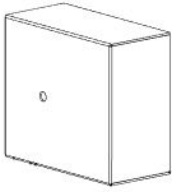

F07 COVER - A4M02228
(x1) 1 9/16"x2 7/8"x3 1/4" (39.5x73x82)



F05 KEY STOCK - A4M02226
(x1) 1/2"x1/2"x3 3/4" (13.0x13.0x95)

Qty	PartNo	Description
1	H101187	BOLT PPH 8-32x1 1/8 BLK

- ALIGN SCREW HOLES.

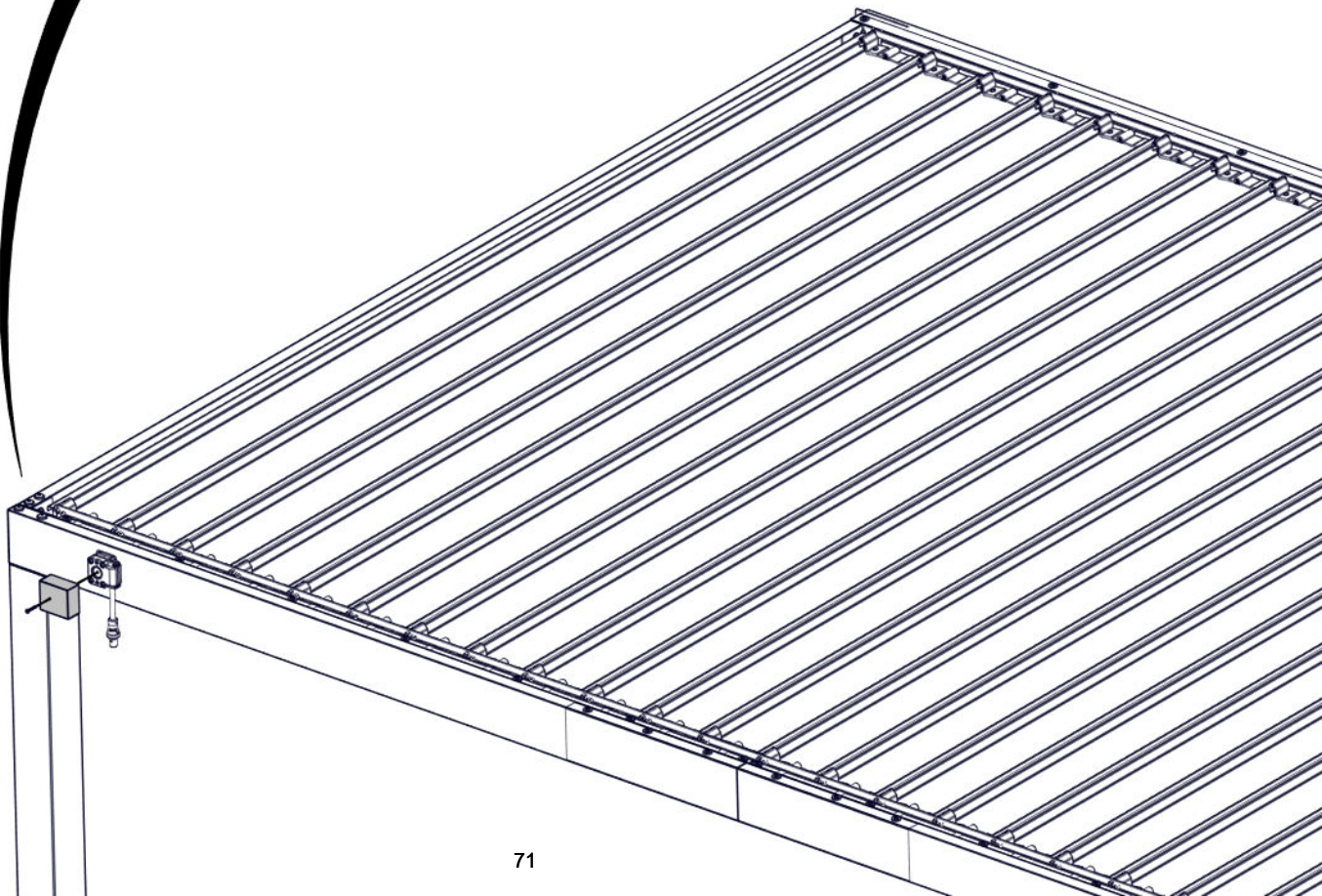
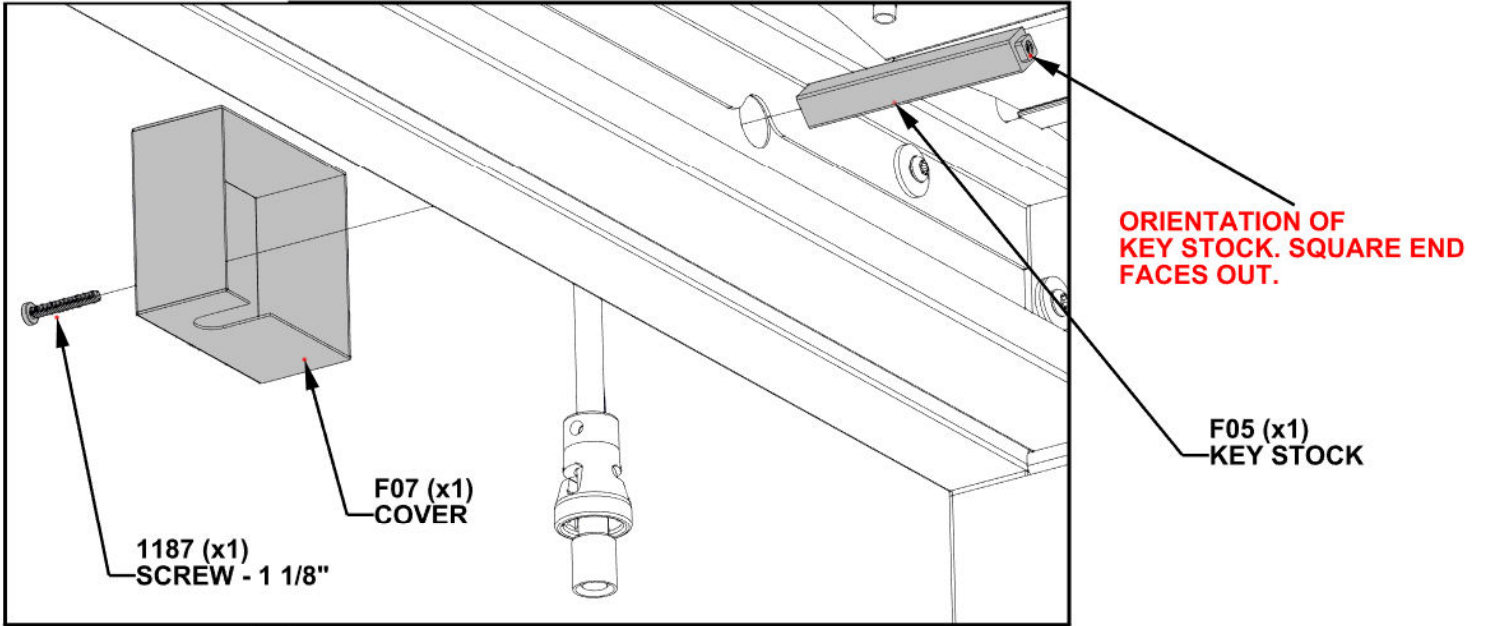

STEP 28A - LOUVER MECHANISM

Qty	PartNo	Description
2	H100474	WASHER FLAT 9x18 BLK
1	H100653	NUT LOCK 1/4 BLK
1	H101189	LOW PROFILE SHOULDER BOLT 1/4-20x3/8" BLK

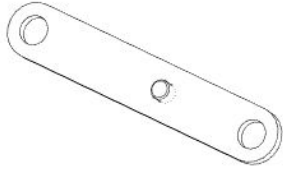

F03 LINKAGE STRAP - A4M02229
(x1) 1/8"x11/16"x3 13/16" (3x17x97)

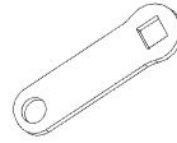

F04 LINKAGE STRAP - A4M02225
(x1) 1/8"x13/16"x2 5/8" (3x20x66)

- LINKAGES MUST BE ORIENTED AS SHOWN BELOW.

- DO NOT OVERTIGHTEN HARDWARE.
- LINKAGES SHOULD BE ABLE TO ROTATE FREELY.

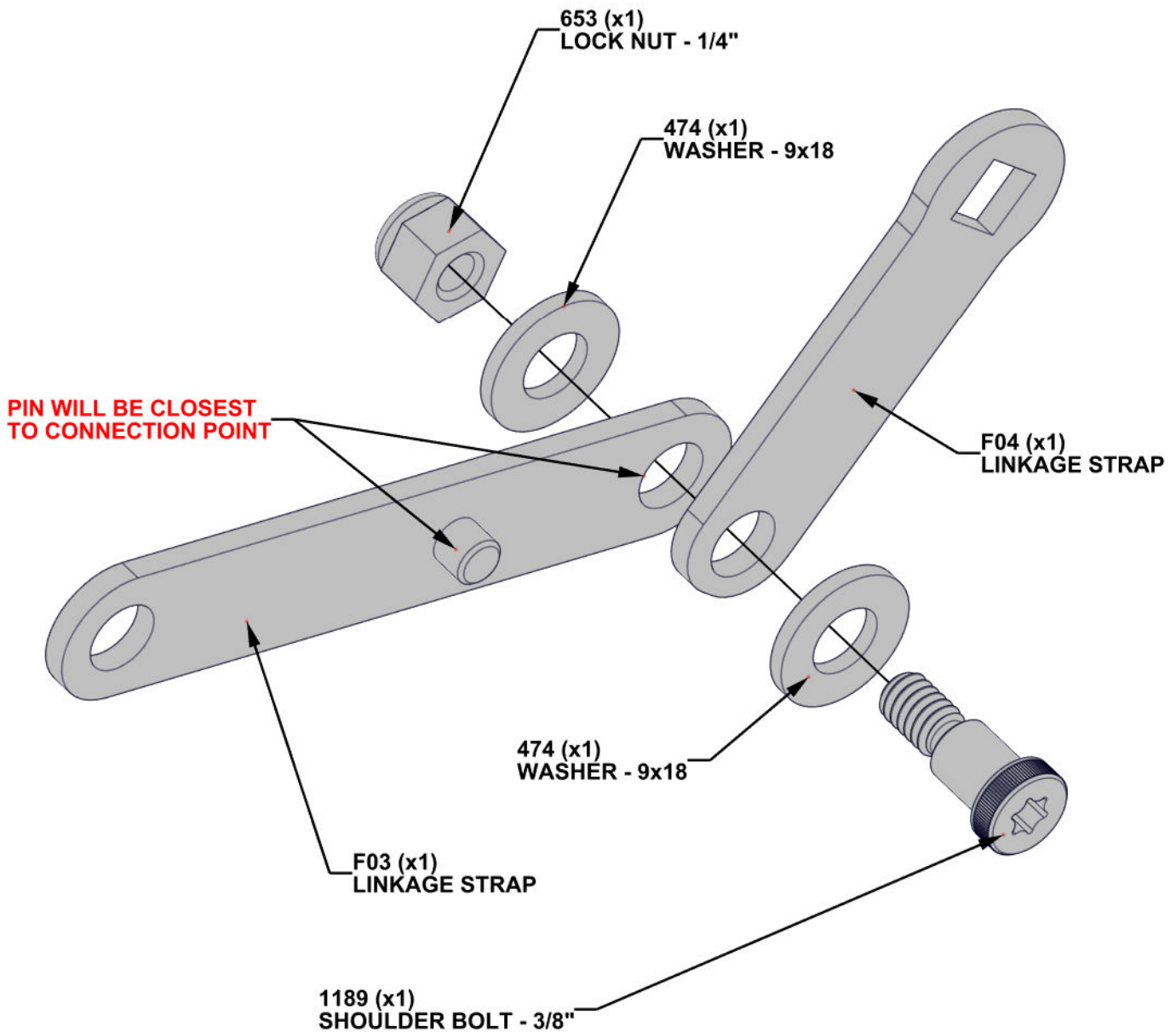

STEP 28B - LOUVER MECHANISM

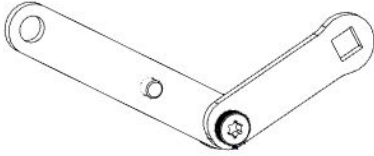

LINKAGE ASSEMBLY
STEP - 28A

Qty	PartNo	Description
1	H100774	WASHER SPLIT 1/4 BLK
3	H100474	WASHER FLAT - 9x18 BLK
1	H101101	TORX PAN HEAD 1/4-20x3/4"BLK
1	H100653	NUT LOCK 1/4 BLK
1	H101189	LOW PROFILE SHOULDER BOLT 1/4-20x3/8" BLK

- LINKAGES MUST BE ORIENTED AS SHOWN BELOW.

- DO NOT OVERTIGHTEN HARDWARE.
- LINKAGES SHOULD BE ABLE TO ROTATE FREELY.

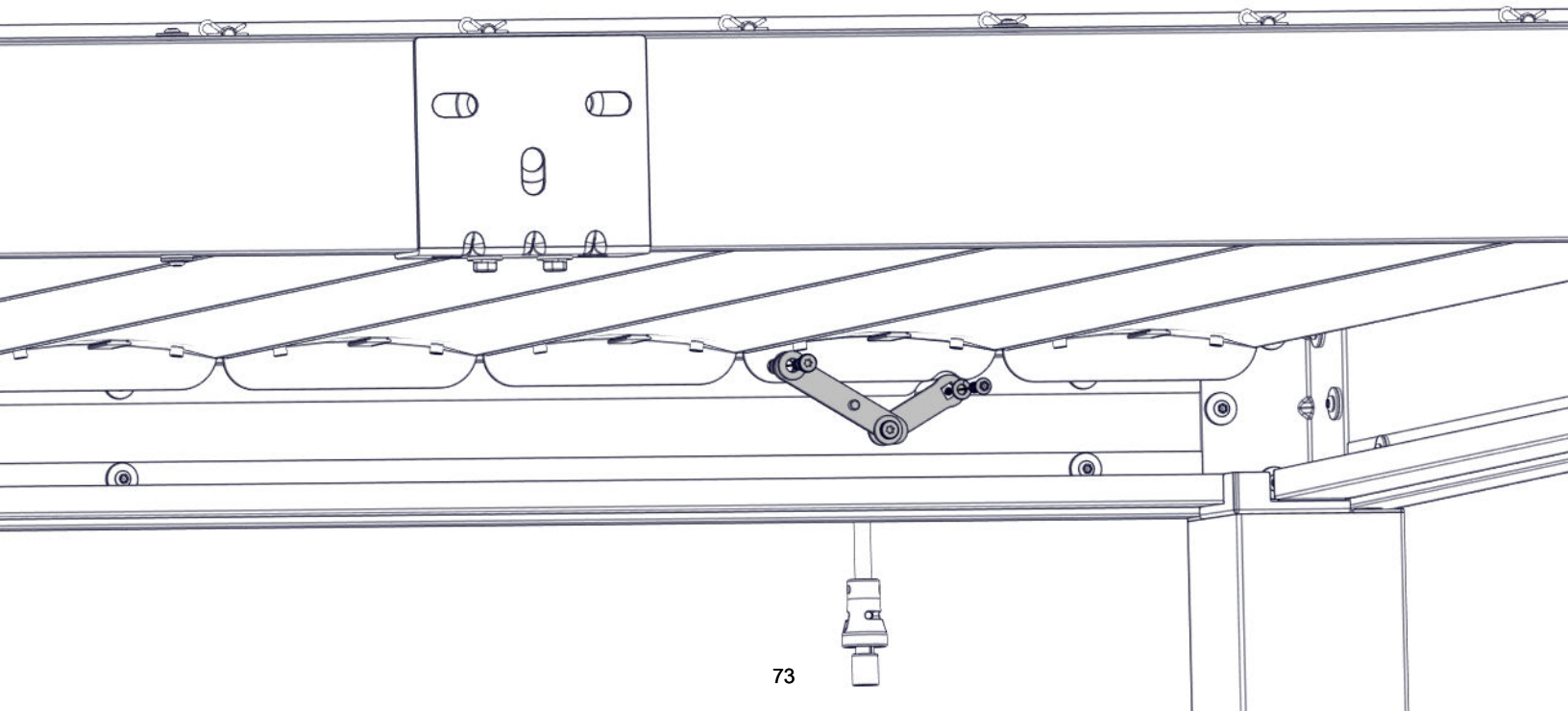
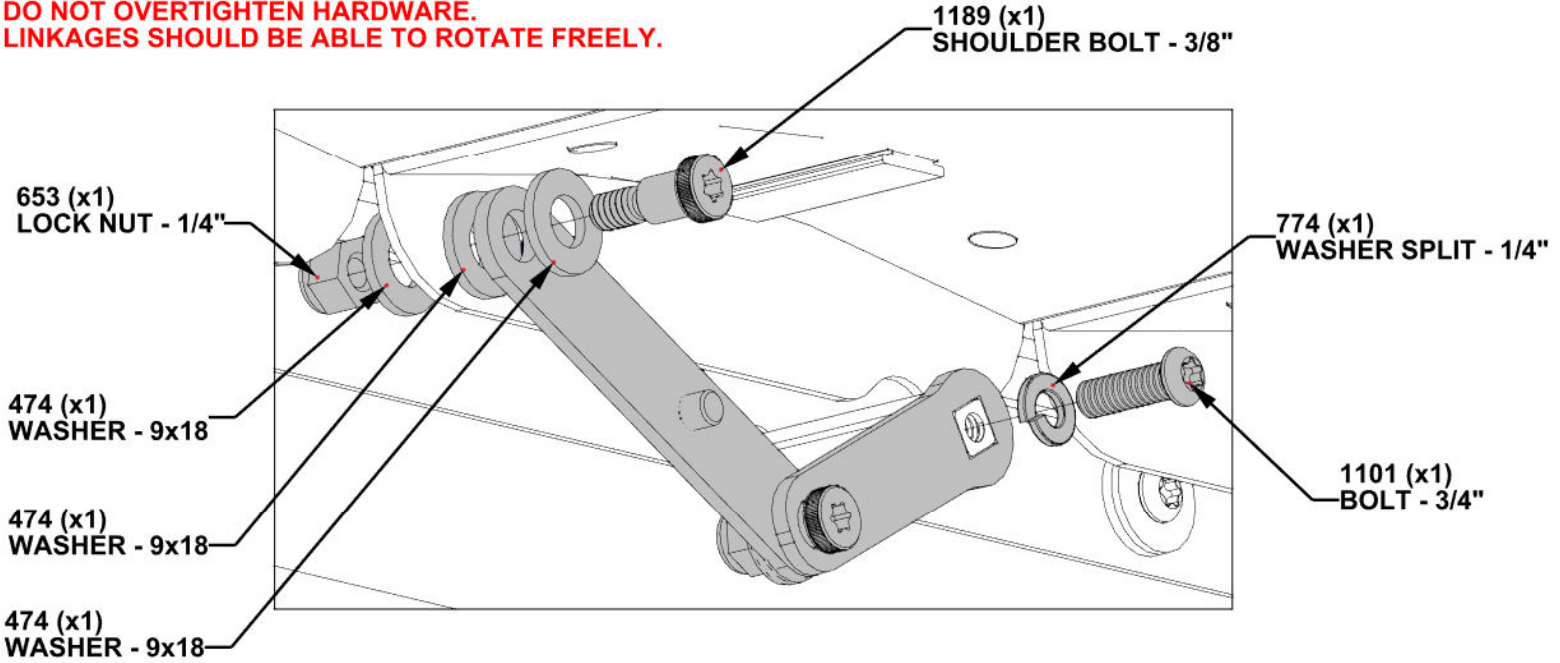

STEP 28C - LOUVER MECHANISM

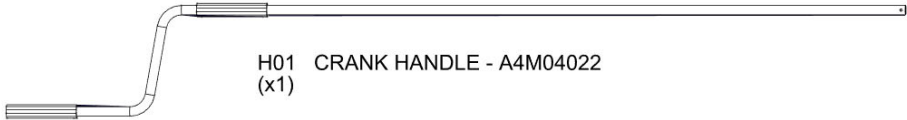

- CONNECT CRANK HANDLE TO MECHANISM. TURN HANDLE TO LOCK IN PLACE

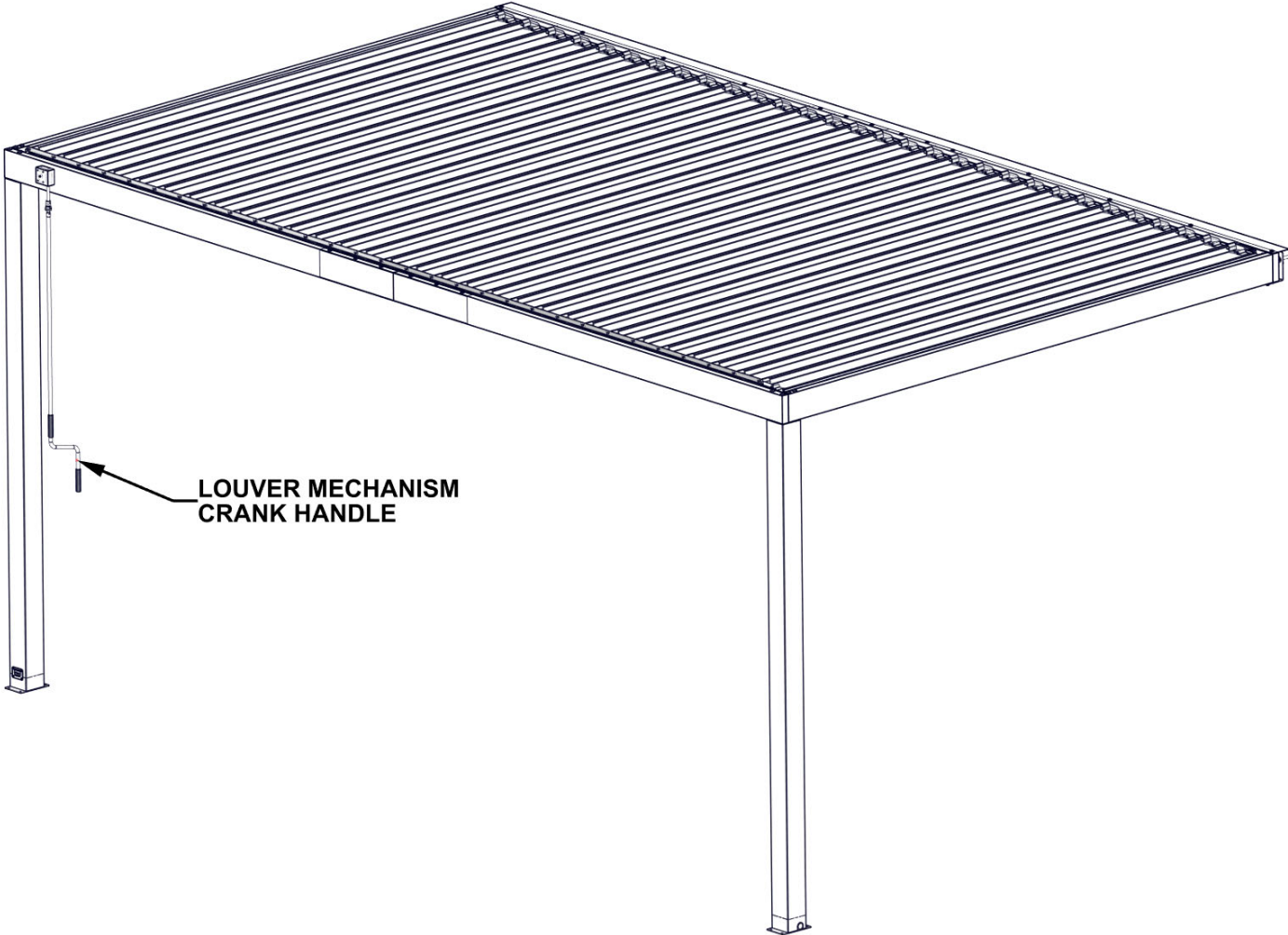

STEP 29 - PERGOLA ANCHORING

Qty	PartNo	Description
8	H100630	WASHER FLAT 8x19 BLK
8	H101305	CONCRETE ANCHOR 1/4"x3" BLK

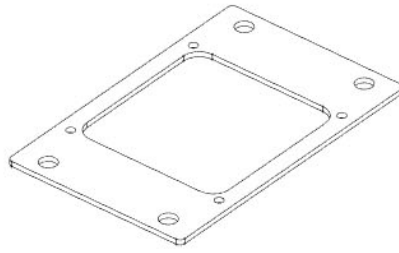

A4M04024 SHIM
(x4)

- NOTES:**
- MANUFACTURER RECOMMENDS INSTALLATION ON CONCRETE SURFACE OR CONCRETE POST PADS. SEE BELOW.
 - FOR INSTALLATION ON WOOD DECKS, YOU MUST ENSURE THERE IS AMPLE STRUCTURAL SUPPORT UNDER DECK.
 - PRE-DRILL HOLES FOR CONCRETE ANCHORS USING A 3/16" [5mm] CONCRETE DRILL BIT.
 - REPEAT THIS STEP FOR TWO POSTS.
 - THERE NEEDS TO BE A SLIGHT SLOPE AWAY FROM INSTALLATION WALL TO ALLOW FOR PROPER DRAINAGE FLOW.

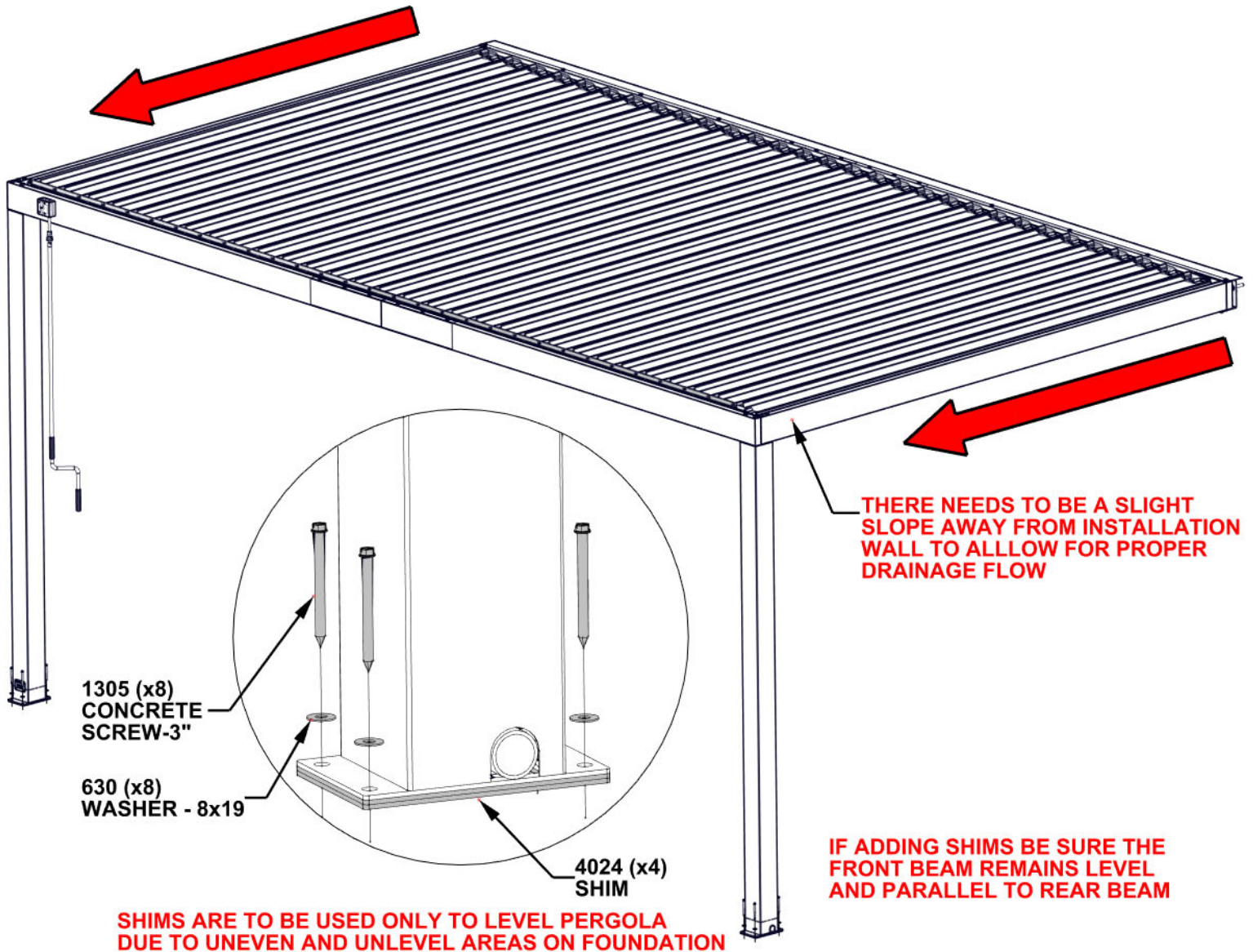

STEP 30 - PREVENTATIVE MAINTENANCE

NOTE: IT IS IMPORTANT TO TAKE CAUTION WHEN HIGH WINDS OR WINTER WEATHER SUCH AS ICE OR SNOW IS EXPECTED. IF INCLEMENT WEATHER ARISES, IT IS RECOMMENDED TO TURN LOUVERS INTO THE FULLY OPEN (UPRIGHT) POSITION. THIS WILL PREVENT DAMAGE TO THE STRUCTURE AND DECREASE THE CHANCES OF STRUCTURE OR LOUVER DAMAGE.

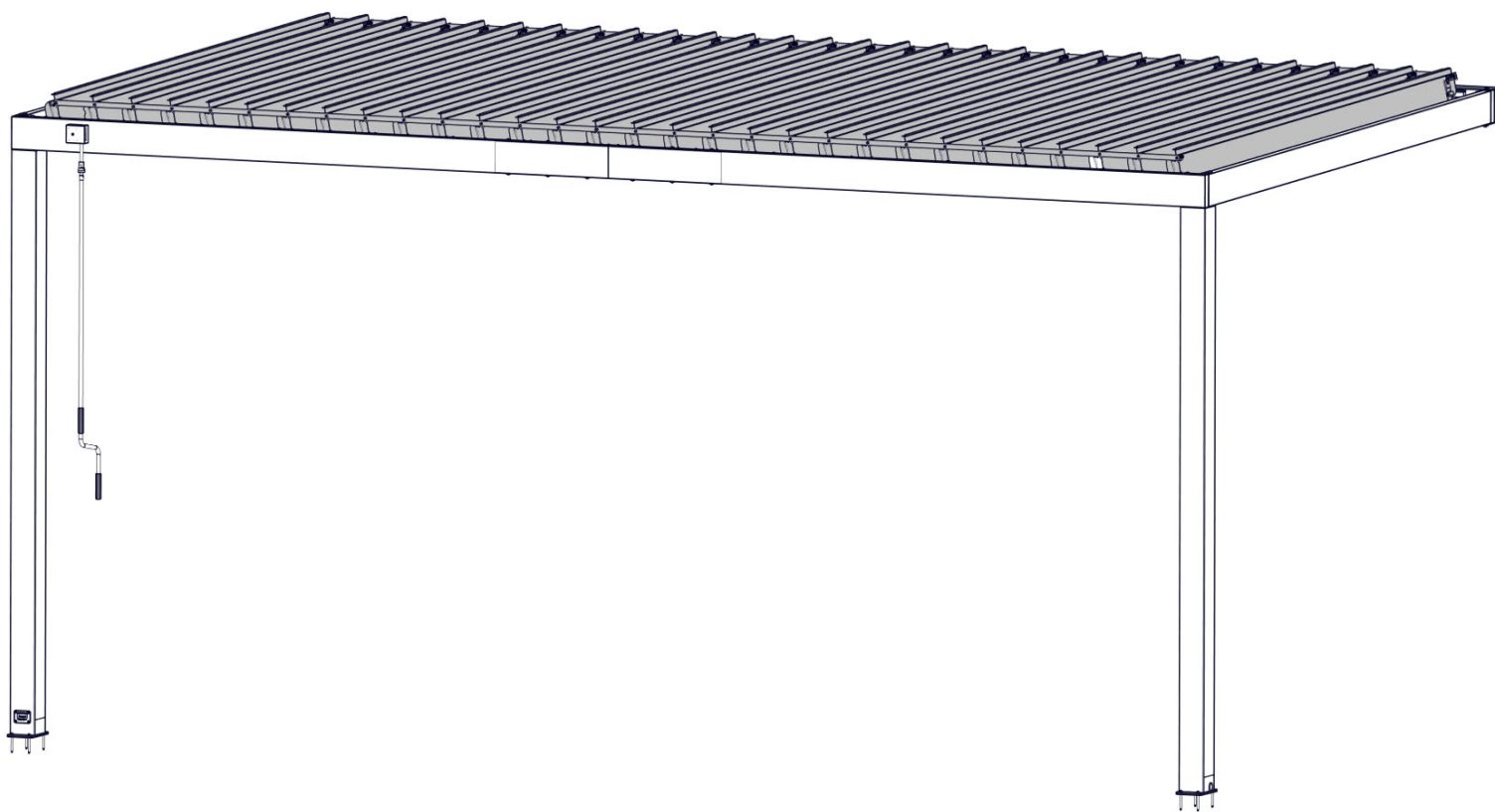

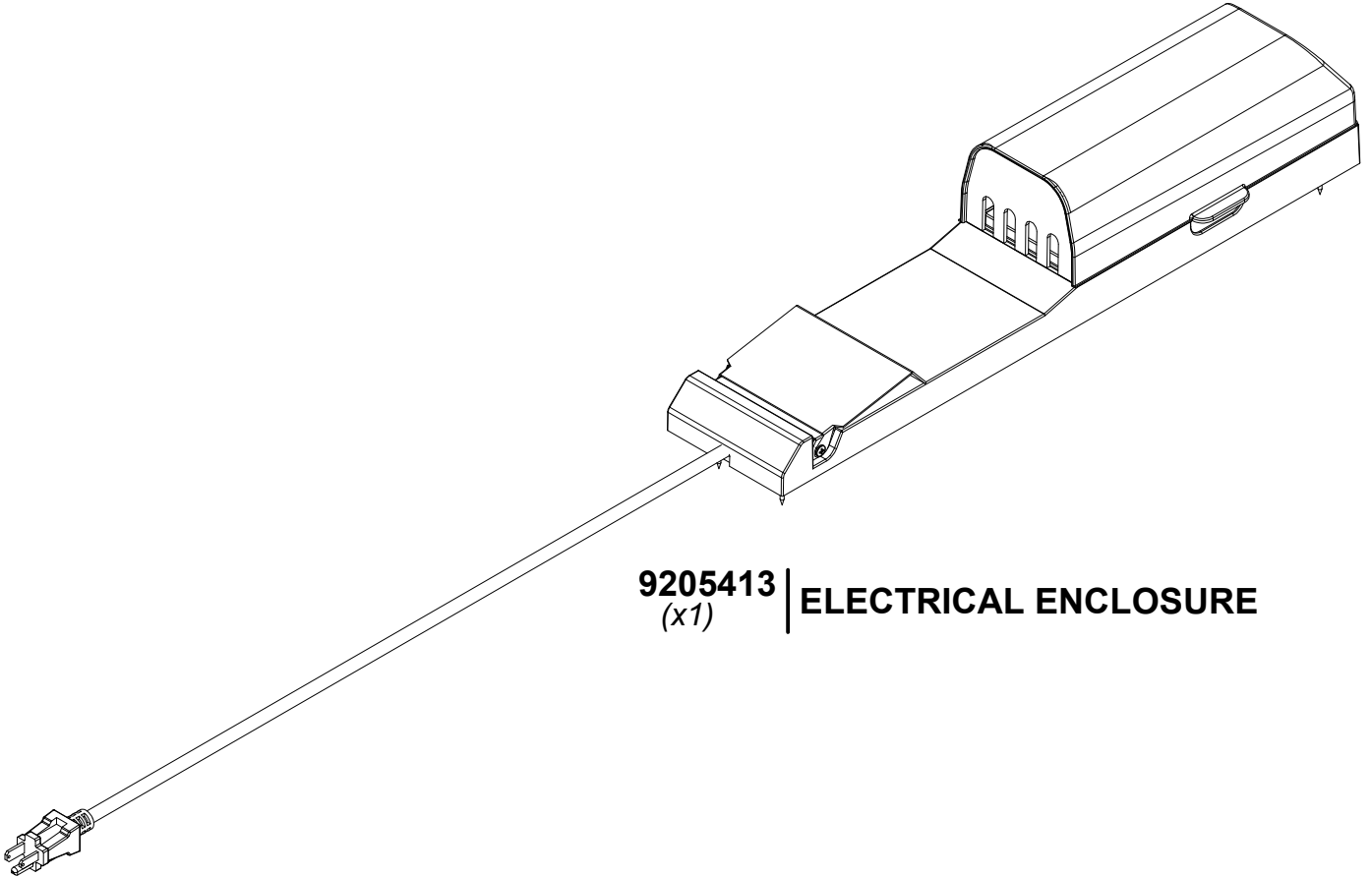

9205413 | **ELECTRICAL ENCLOSURE**
(x1)