



Manufactured by:
Backyard Discovery
3305 Airport Drive, Pittsburg, KS 66762
800-856-4445

Basepoint Business Centre: Rivermead Drive, Westlea, Swindon SN5 7EX Phone: 0800-118-2476
J.P. Coenstraat 7, The Bridge, The Hague, 2595 WP, Netherlands Phone: 08005678990

LENNON 4-6 PERSON CUBE SAUNA

MODEL # : 2504677, 2504677-V

THE ASSEMBLY MANUAL MUST BE RETAINED SINCE IT CONTAINS IMPORTANT INFORMATION
LICENSED ELECTRICIAN WORK IS REQUIRED TO INSTALL A DEDICATED 240V/50AMP CIRCUIT



WARNING

Cancer and Reproductive Harm
www.P65Warnings.ca.gov



Please visit www.backyarddiscovery.com

For the most up to date assembly manual, to register your product, or to order replacement parts *Para obtener instrucciones en español, visite* www.backyarddiscovery.com



EASY STEP-BY-STEP
3D INTERACTIVE INSTRUCTIONS
DOWNLOAD THE FREE APP



OWNER'S MANUAL - BASIC SETUP DIMENSIONS & ASSEMBLY NOTES

CHOOSE A GOOD LOCATION FOR YOUR SAUNA!

It is critically important the sauna foundation is sturdy and level. An unstable foundation can cause the sauna to tilt, shift, or fall, leading to injury.

Pay close attention to the items needed for each step. Make sure you are using the correct hardware for each step.

- Using incorrect hardware may result in improper assembly.
- Ensure the surface is firm and level and can support the weight of the sauna and its users. (1400+ lbs.)
- Many garages, basements or deck floors are sloped for drainage. A slight slope will not be an issue. A more pronounced slope will require shimming to make the sauna level.
- Consider a concrete slab, paver stones, or something similar to prevent the cradle supports from settling in the ground. Concrete anchors are provided in the kit.
- If installing on the ground or gravel surface, ground anchors are included in the kit.
- If installing on a deck, confirm there is ample structural support under the deck. The hardware to mount to a wood deck is NOT included and will need to be purchased separately.
- Consider distance from your electrical service box as this can greatly impact the cost of needed electrical work
- If located in an area that tends to receive high winds, it is recommended to take extra precautions to ensure the door does not blow open. In most situation, this should not be a concern.

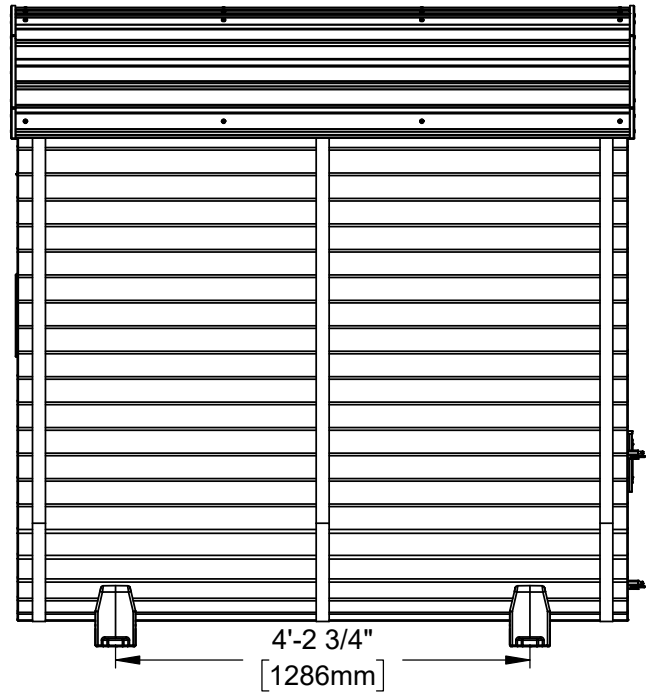
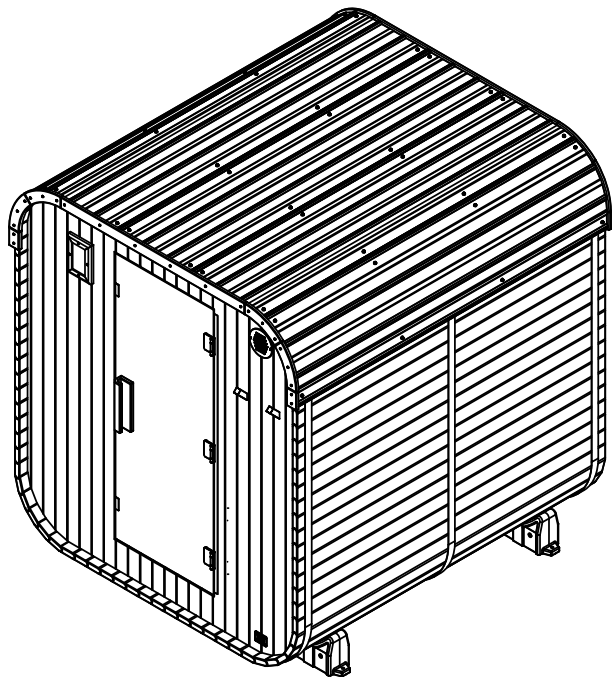
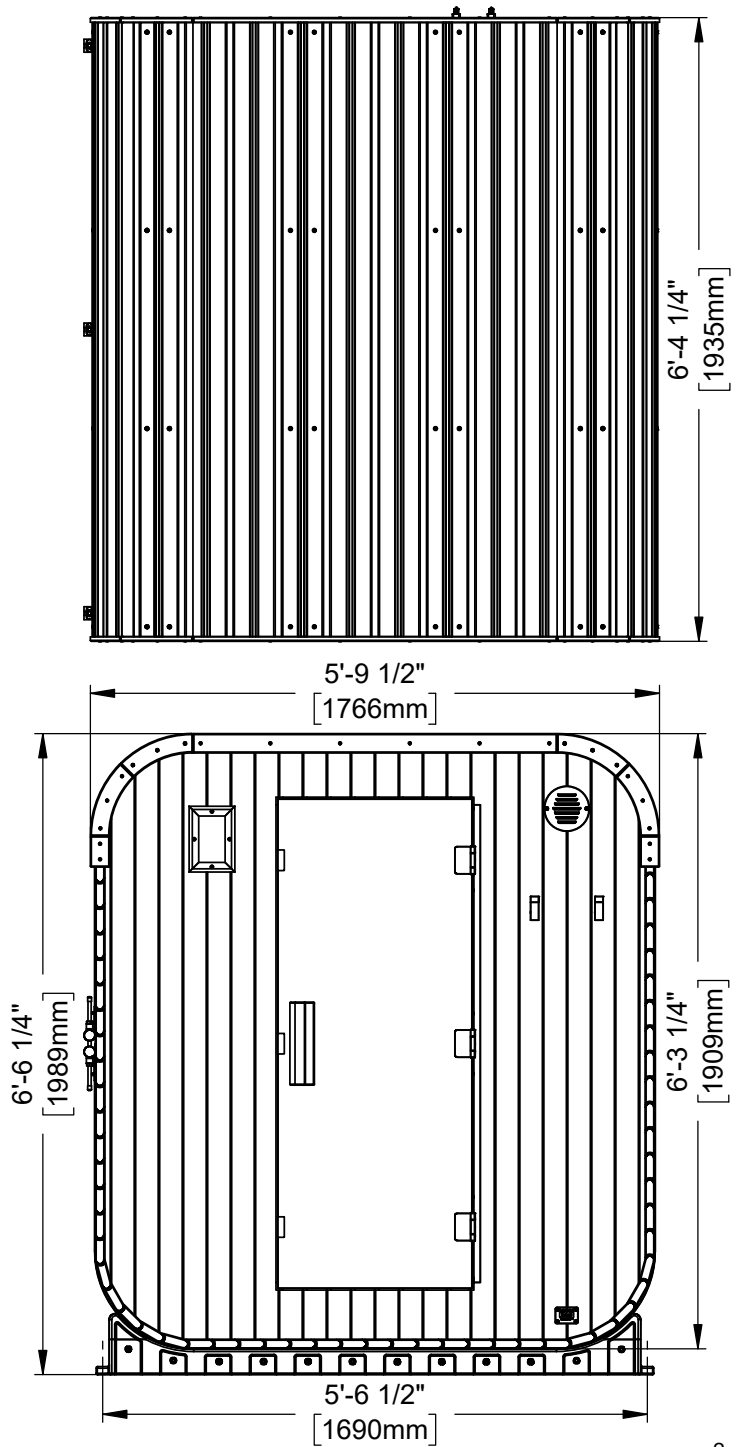

OWNER'S MANUAL - ANCHORING LAYOUT

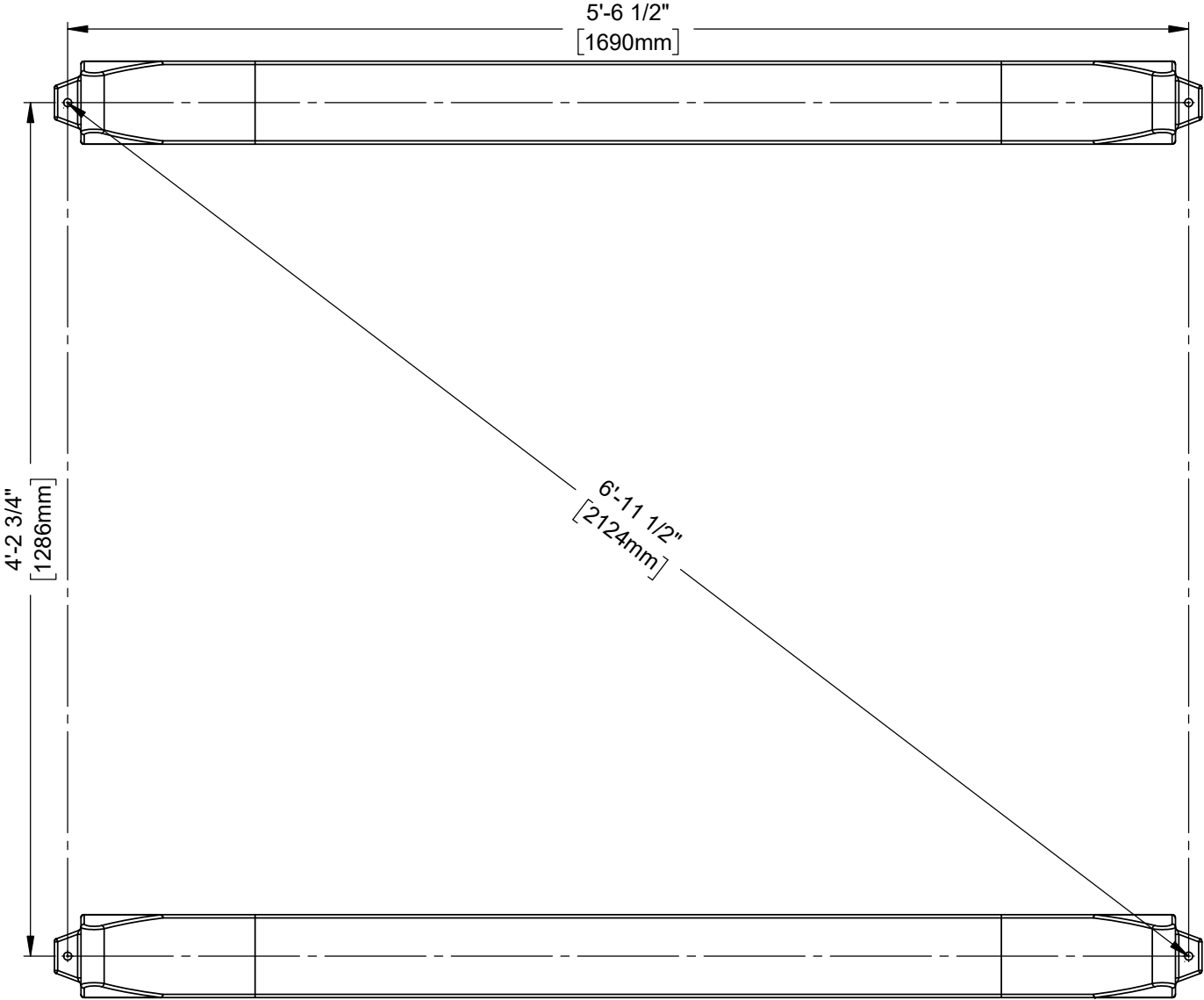

OWNER'S MANUAL - PARTS IDENTIFICATION

WOOD COMPONENTS (NOT TO SCALE)



NG01 SLAT - W4L21949
(x3) 13/16"x3 3/8"x65 3/4" (20x86x1670)

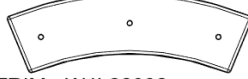

NG02 TRIM - W4L22032
(x8) 13/16"x3 1/8"x9 9/16" (20x80x243)



NR01 TRIM - W4L22033
(x2) 13/16"x2 3/8"x44 1/2" (20x60x1130)



NR02 TRIM - W4L22034
(x4) 13/16"x2 3/8"x4 1/4" (20x60x108)



NR03 HEATER GUARD BOARD - W4L22036
(x5) 13/16"x2 3/8"x20 3/8" (20x60x518)



NR04 HEATER GUARD BOARD - W4L22037
(x5) 13/16"x2 3/8"x15 11/16" (20x60x398)



OG01 PERIMETER BOARD - W4L21936
(x63) 1 3/16"x3 3/8"x74 5/8" (30x86x1895)



OG02 SEAT CLEAT - W4L21943
(x1) 1 3/16"x3 3/8"x60 15/16" (30x86x1548)



OG03 SEAT CLEAT - W4L21944
(x2) 1 3/16"x3 3/8"x23 1/16" (30x86x586)



OG04 SEAT CLEAT - W4L21951
(x2) 1 3/16"x3 3/8"x23 1/16" (30x86x586)



OG05 CLEAT - W4L22030
(x1) 1 3/16"x3 3/8"x60 15/16" (30x86x1548)



OG06 CLEAT - W4L22031
(x2) 1 3/16"x3 3/8"x18 1/8" (30x86x460)

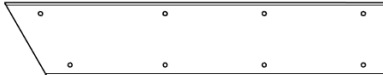

OG07 CLEAT - W4L22039
(x2) 1 3/16"x3 3/8"x17 11/16" (30x86x450)

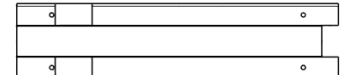

OG08 WIREWAY BOARD - W4L22040
(x1) 1 3/16"x3 3/8"x14 7/16" (30x86x367)

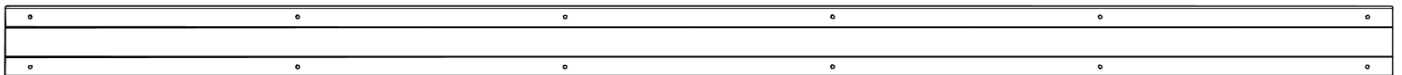

OG09 WIREWAY BOARD - W4L22041
(x1) 1 3/16"x3 3/8"x65 9/16" (30x86x1665)

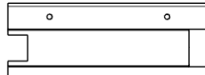

OG10 WIREWAY BOARD - W4L22042
(x1) 1 3/16"x3 3/8"x7 5/8" (30x86x193)



OG12 PERIMETER DRAIN BOARD - W4L22044
(x1) 1 3/16"x3 3/8"x74 5/8" (30x86x1895)

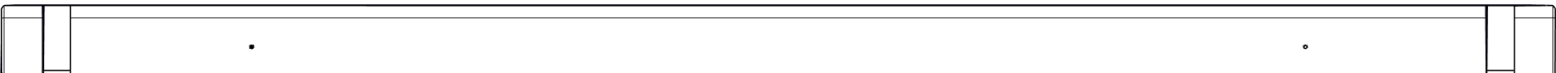

OG13 PERIMETER BOARD - W4L22322
(x20) 1 3/16"x3 3/8"x74 5/8" (30x86x1895)



OO01 SLAT CLEAT - W4L21950
(x2) 1 3/16"x1 3/16"x14 15/16" (30x30x380)



OO03 HEATER GUARD BOARD - W4L22038
(x2) 1 3/16"x1 3/16"x16 1/8" (30x30x410)

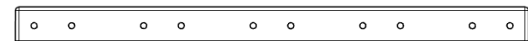

OO04 HEATER GUARD BOARD - W4L22035
(x1) 1 3/16"x1 3/16"x16 1/8" (30x30x410)

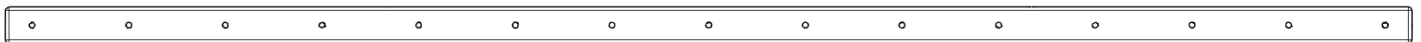

OO05 FLOOR CLEAT - W4L22600
(x2) 1 3/16"x1 3/16"x45 1/4" (30x30x1150)

OWNER'S MANUAL - PARTS IDENTIFICATION

WOOD COMPONENTS (NOT TO SCALE)

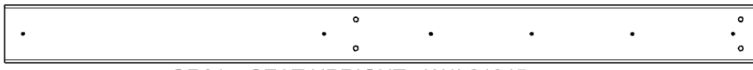

OR01 SEAT UPRIGHT - W4L21945
(x2) 1 3/16"x2 3/8"x30 11/16" (30x60x780)



OR02 ANGLE BRACE - W4L21946
(x4) 1 3/16"x2 3/8"x10 7/8" (30x60x276)

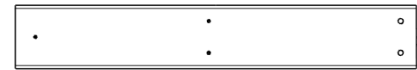

OR03 SEAT UPRIGHT - W4L21947
(x2) 1 3/16"x2 3/8"x14 15/16" (30x60x380)



W01 SEAT TRIM - W4L21948
(x2) 1 9/16"x3 3/8"x65 3/4" (40x86x1670)

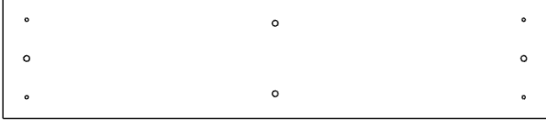

Y01 HEATER SPACER BOARD - W4L22601
(x2) 5/8"x4"x18 1/4" (16x102x464)

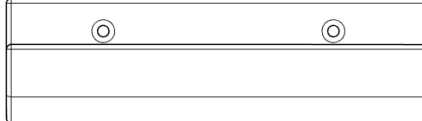

AM01 DOOR HANDLE - W4L21937
(x1) 2 1/4"x3"x10 3/16" (57x76x258)

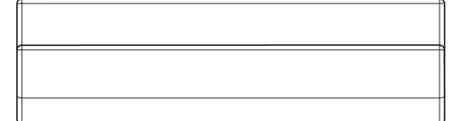

HA01 HANDLE ASSEMBLY - W2A04820
(x1) 2 1/4"x3"x10 3/16" (57x76x258)

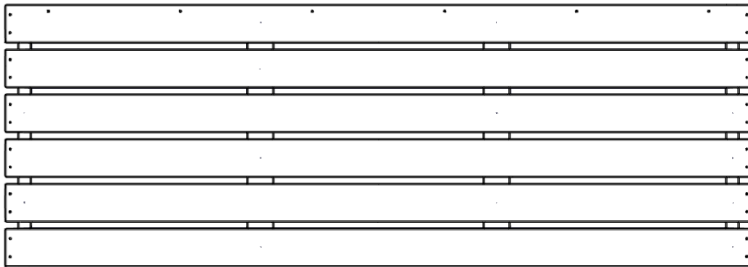

BA01 BENCH ASSEMBLY - W2A04821
(x1) 1 15/16"x23 1/16"x65 3/4" (50x586x1670)

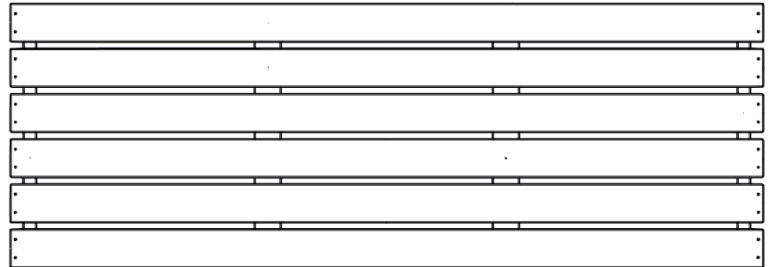

BA02 BENCH ASSEMBLY - W2A04822
(x1) 1 15/16"x23 1/16"x65 3/4" (50x586x1670)

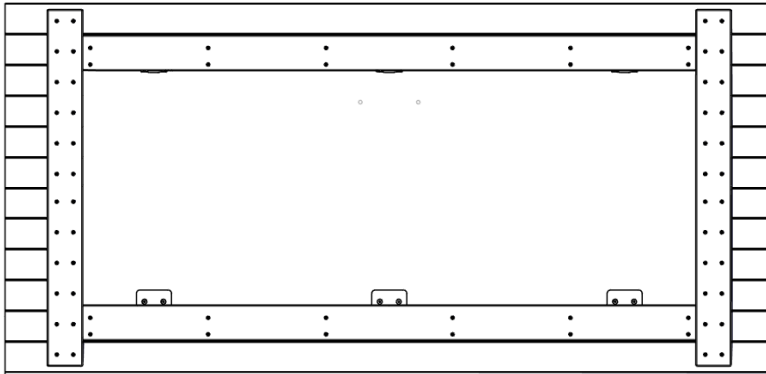

WP01 WALL PANEL ASSEMBLY - W2A04816
(x1) 2 3/8"x35 5/8"x73 1/8" (60x906x1858)

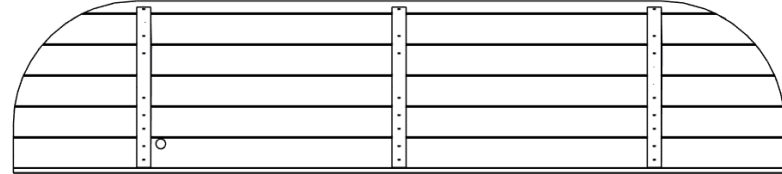

WP02 WALL PANEL - W2A04817
(x1) 3 3/8"x16 5/16"x73 1/8" (35x415x1858)

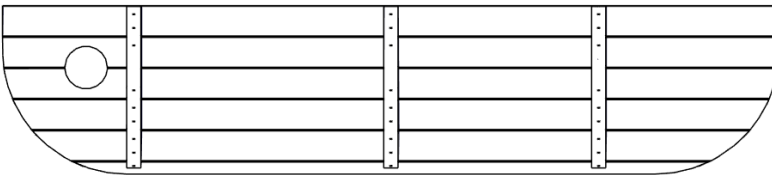

WP03 WALL PANEL - W2A04818
(x1) 1 3/8"x15 7/8"x73 1/8" (35x403x1858)

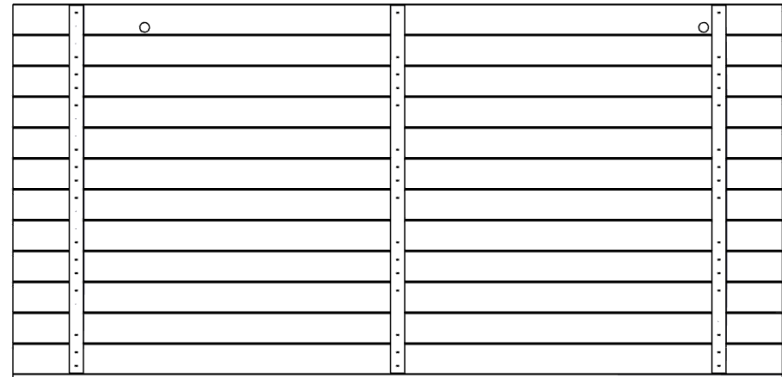

WP04 WALL PANEL - W2A04819
(x1) 1 3/8"x35 5/8"x73 1/8" (35x906x1858)

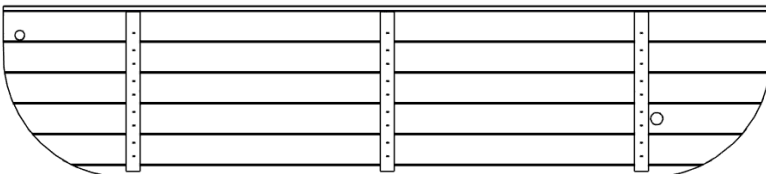

WP05 WALL PANEL - W2A04823
(x1) 1 3/8"x16 5/16"x73 1/8" (35x415x1858)

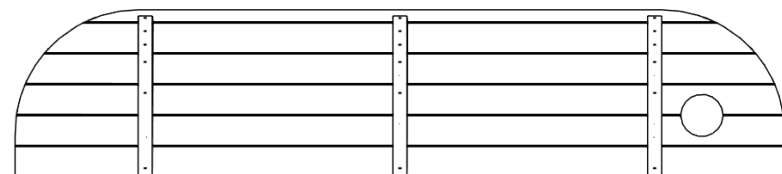

WP06 WALL PANEL - W2A04883
(x1) 3 3/8"x15 7/8"x73 1/8" (35x403x1858)

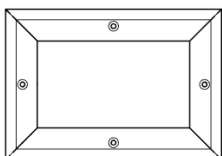

TF01 TRIM FRAME - W2A04797
(x1) 7/8"x5 9/16"x8 1/16" (22x142x204)

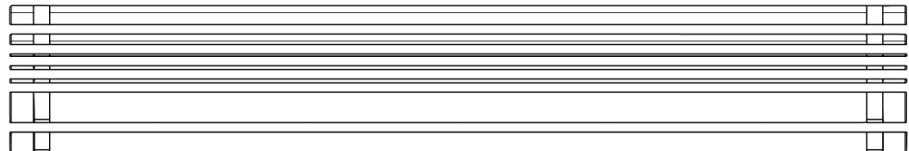

BOARD SPACER KIT - W2A04848
(x1)

OWNER'S MANUAL - PARTS IDENTIFICATION

ACCESSORY COMPONENTS (NOT TO SCALE)



A4M05663 29 GA SHEETING
(x5)

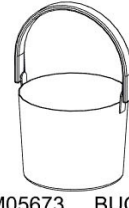

A4M05673 BUCKET
(x1)



A4M05596 LADLE
(x1)

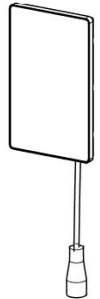

A4M5590-02 CONTROL PANEL
(x1)

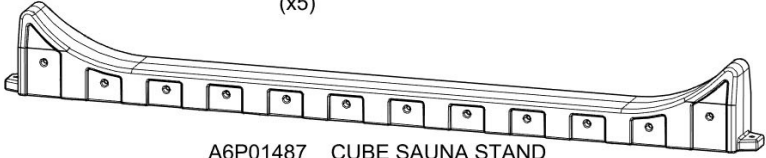

A6P01487 CUBE SAUNA STAND
(x2)

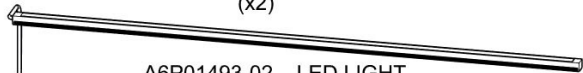

A6P01493-02 LED LIGHT
(x2)

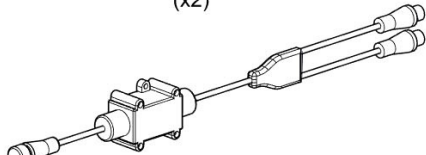

A4M01493-06 REMOTE MODULE
(x1)



A4M05590-10 WIRING HARNESS
(x1)

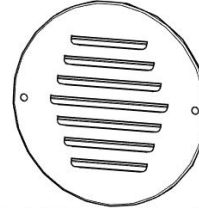

A4M05285 VENT COVER
(x2)

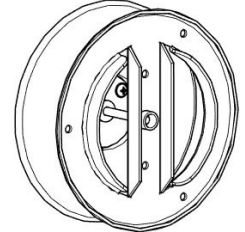

A4M05592 VENT ASSEMBLY
(x1)



A4M05590-03 CONTROL PANEL MOUNTING BRACKET
(x1)

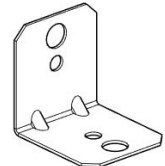

A4M00555 L BRACKET BLK
(x4)

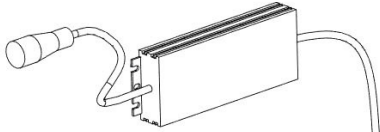

A6P01493-03 LED POWER SUPPLY
(x1)



A4M05667 GROUND STAKE
(x4)

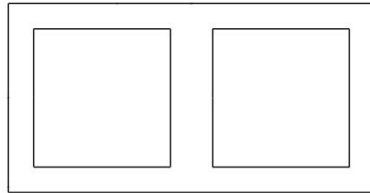

T01 THERMOMETER
(x1)

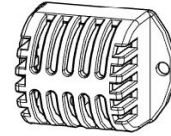

A4M05590-08 TEMPERATURE SENSOR
(x1)

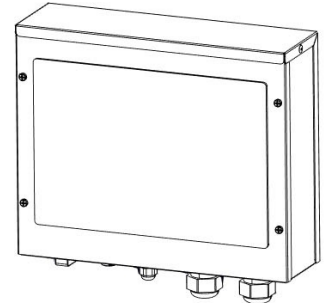

A4M05590-01 CONTROL PANEL
(x1)

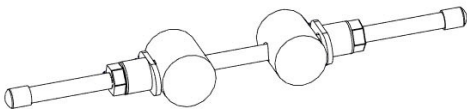

A4M05671 BANDING CINCH
(x3)

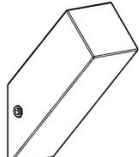

A4M05672 TOWEL HANGER
(x2)

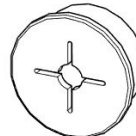

A6P01467 25mm SILICONE GROMMET
(x4)

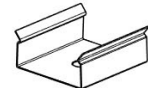

A6P01493-04 LIGHT CLIP
(x4)



A4M05662 BANDING
(x3)

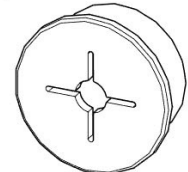

A6P01468 30mm SILICONE GROMMET
(x1)



A6P01448 ZIP CABLE TIE
(x10)

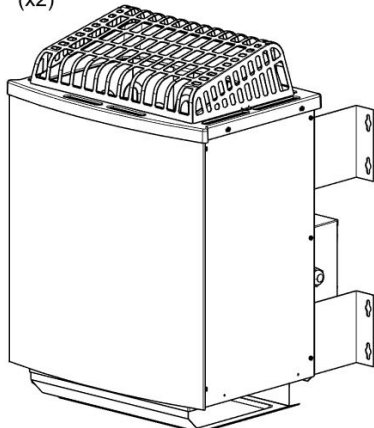

9250253 9KW ELECTRIC SAUNA HEATER
(x1)



A6P01490 SAUNA POWER WIRE
(x1)

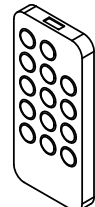

A6P01493-05 REMOTE
(x1)

OWNER'S MANUAL - PARTS IDENTIFICATION

HARDWARE COMPONENTS

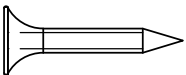

H101423 SCREW TFH 8X7/8 SS-BLK
(x4) 8x7/8

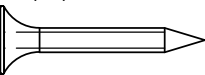

H101424 SCREW TFH 8X1 SS-BLK
(x1) 8x1

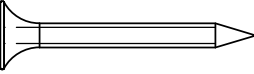

H101426 SCREW TFH 8X1 1/4 SS-BLK
(x3) 8x1-1/4

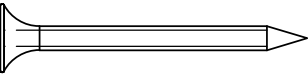

H101427 SCREW TFH 8X1 1/2 SS-BLK
(x8) 8x1-1/2

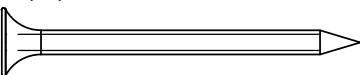

H101428 SCREW TFH 8X1 3/4 SS-BLK
(x121) 8x1-3/4

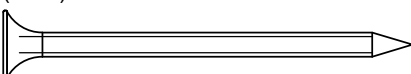

H101429 SCREW TFH 8X2 SS-BLK
(x236) 8x2

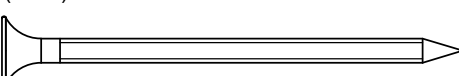

H101430 SCREW TFH 8X2 1/4 SS-BLK
(x12) 8x2-1/4

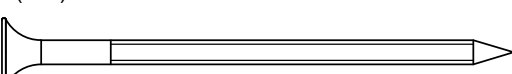

H101431 SCREW TFH 8X2 1/2 SS-BLK
(x12) 8x2-1/2

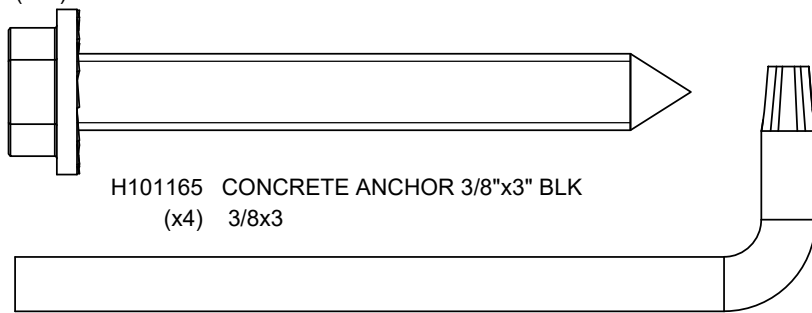

H101165 CONCRETE ANCHOR 3/8"x3" BLK
(x4) 3/8x3

H100114 TORX WRENCH
(x1) T-30

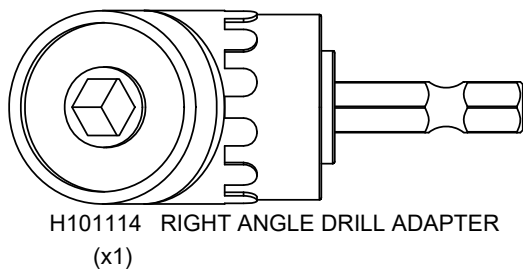

H101114 RIGHT ANGLE DRILL ADAPTER
(x1)

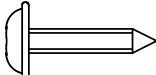

H101437 SCREW TWH 8x5/8 SS-BLK
(x4) 8x5/8

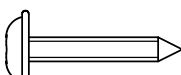

H101438 SCREW TWH 8x3/4 SS-BLK
(x12) 8x3/4

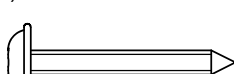

H101440 SCREW TWH 8x1 SS-BLK
(x11) 8x1

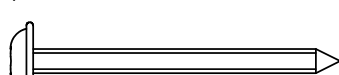

H101443 SCREW TWH 8x1 1/2 SS-BLK
(x16) 8x1-1/2

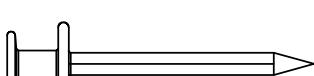

H101468 SCREW RAISED HEAD BLK
(x8) 8x1

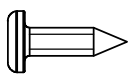

H101409 SCREW PPH 4x1/2 BLK
(x10) 4x1/2



H100627 SCREW PFH BLK
(x2) 6x3/4

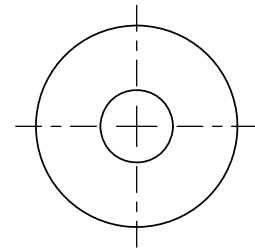

H101403 POLY WASHER
(x4)

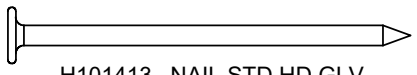

H101413 NAIL STD HD GLV
(x40)

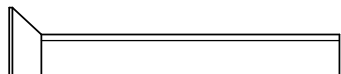

H101402 SCREW TFH 1/4-20 X 1 5/8 SS
(x2) 1/4-20 X 1 5/8

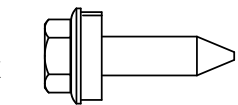

H101117 SCREW WOODGRIP
(x40) 10x3/4

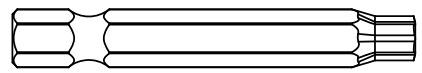

H100147 TORX BIT
(x1) T-30

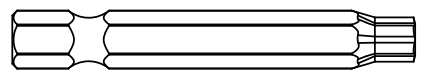

H100879 TORX BIT
(x1) T-20

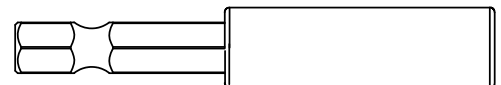

H101100 MAGNETIC DRIVER
(x1)

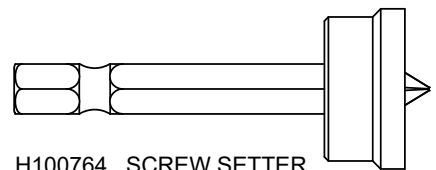

H100764 SCREW SETTER
(x1)

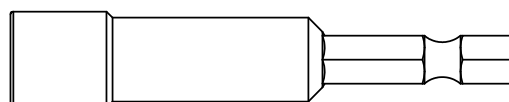

H101106 HEX DRIVER
(x1) 5/16

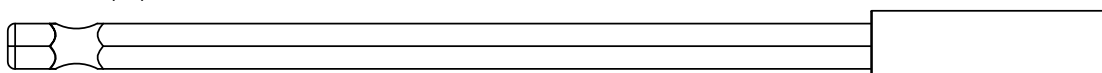

H101278 6" MAGNETIC DRIVER EXTENSION
(x1)

PRE-ASSEMBLY STEP 1 - SORTING PARTS

It is critical for ease of assembly that you take the time to sort and organize the wood and hardware.

WOOD PARTS:

- Organize wood parts by the three-digit, alpha-numeric number stamped on each board (ex. P01).
- If there are multiple boards with the same stamped number, stack those pieces together.
- Stamps can be found on the flat surface of the boards or on the end of the boards.
- Allow yourself plenty of room - the wood pieces can take up a significant amount of space.

NOTE: CARTONS ARE NOT ORGANIZED BY BOARD NUMBER.



HARDWARE PARTS:

- We recommend that you have a separate table to organize the hardware.
- Hardware bags are printed with a seven-digit, alpha-numeric part number.
- You can organize your hardware by part number or group by hardware type (i.e. bolts, nuts, etc.).
- During assembly you only need to reference the last four digits of the number.

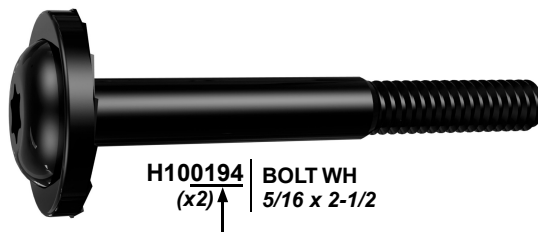

H100194 | BOLT WH
(x2) ↑ 5/16 x 2-1/2

PRE-ASSEMBLY STEP 2 - TOOLS REQUIRED



Cordless Drill or
Electric Drill



Drill Attachments:
Phillips Head

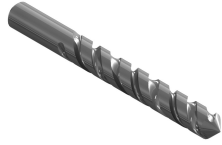

1/8", 3/16", 3/8" &
7/16" Drill Bits



Phillips Screw Driver

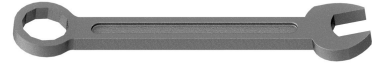

Open End
Wrench 11/16"



3/8" Drive Ratchet, 1/2" &
7/16" STD Sockets, 1/2" &
7/16" Deep Sockets

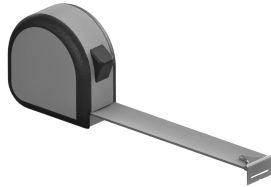

Tape Measure



Claw Hammer

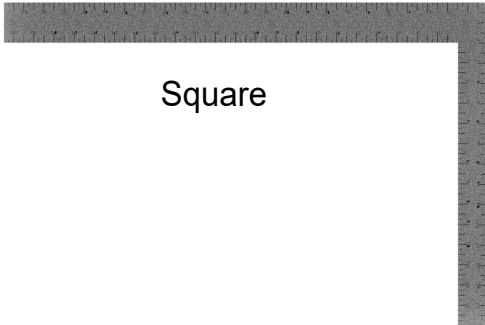

Square



Level 24"

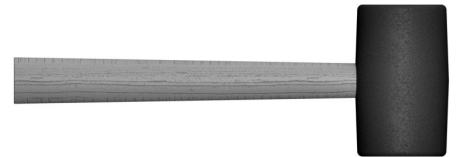

Rubber Mallet -
Optional



Rope 25ft [7.62m] long - Optional

PRE-ASSEMBLY STEP 3 - CHOOSE YOUR ASSEMBLY METHOD

There are several types of assembly instructions available to you.

1. Printed Assembly Manual included with your set
2. BILT APP - 3D interactive instructions
3. Combination of the Printed Manual and BILT APP (Note: Step numbers can differ between the two methods)



The graphic is a promotional banner for the BILT app. It features the BILT logo (a hexagon with a dot inside) and the word "BILT." in a large, bold, sans-serif font. Below the logo, the text reads "Scan for easy 3D instructions" in a large, bold font, followed by "Download the BILT app before you begin" in a smaller font. To the right of the logo is a large QR code with the text "SCAN FOR BILT 3D INSTRUCTIONS" above it and "POWERED BY BILT INTELLIGENT INSTRUCTIONS" below it. Below the QR code are two buttons: "Download on the App Store" and "GET IT ON Google Play". At the bottom of the graphic is a smartphone screen displaying a 3D assembly instruction. The screen shows a 3D model of a structure with a horizontal beam and a triangular support. The interface includes a "Part(s) Needed" button at the top left, a close button (X) at the top right, a list of parts at the bottom left, and navigation arrows at the bottom right.

STEP 1 - BASE ASSEMBLY

QTY	PART NUMBER	DESCRIPTION
2	H101429	SCREW TFH 8X2 SS-BLK

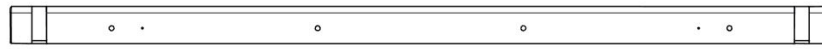

OG12 PERIMETER DRAIN BOARD - W4L22044
(x1) 1 3/16"x3 3/8"x74 5/8" (30x86x1895)

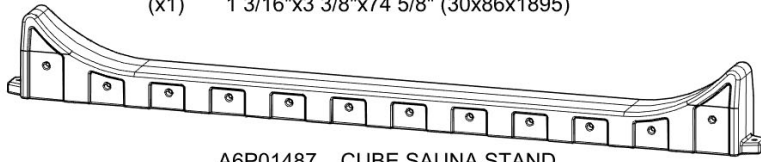

A6P01487 CUBE SAUNA STAND
(x2)

- STAND BASE SUPPORTS UP AND HOLD DIMENSIONS SHOWN.
- ATTACH HARDWARE AS SHOWN.

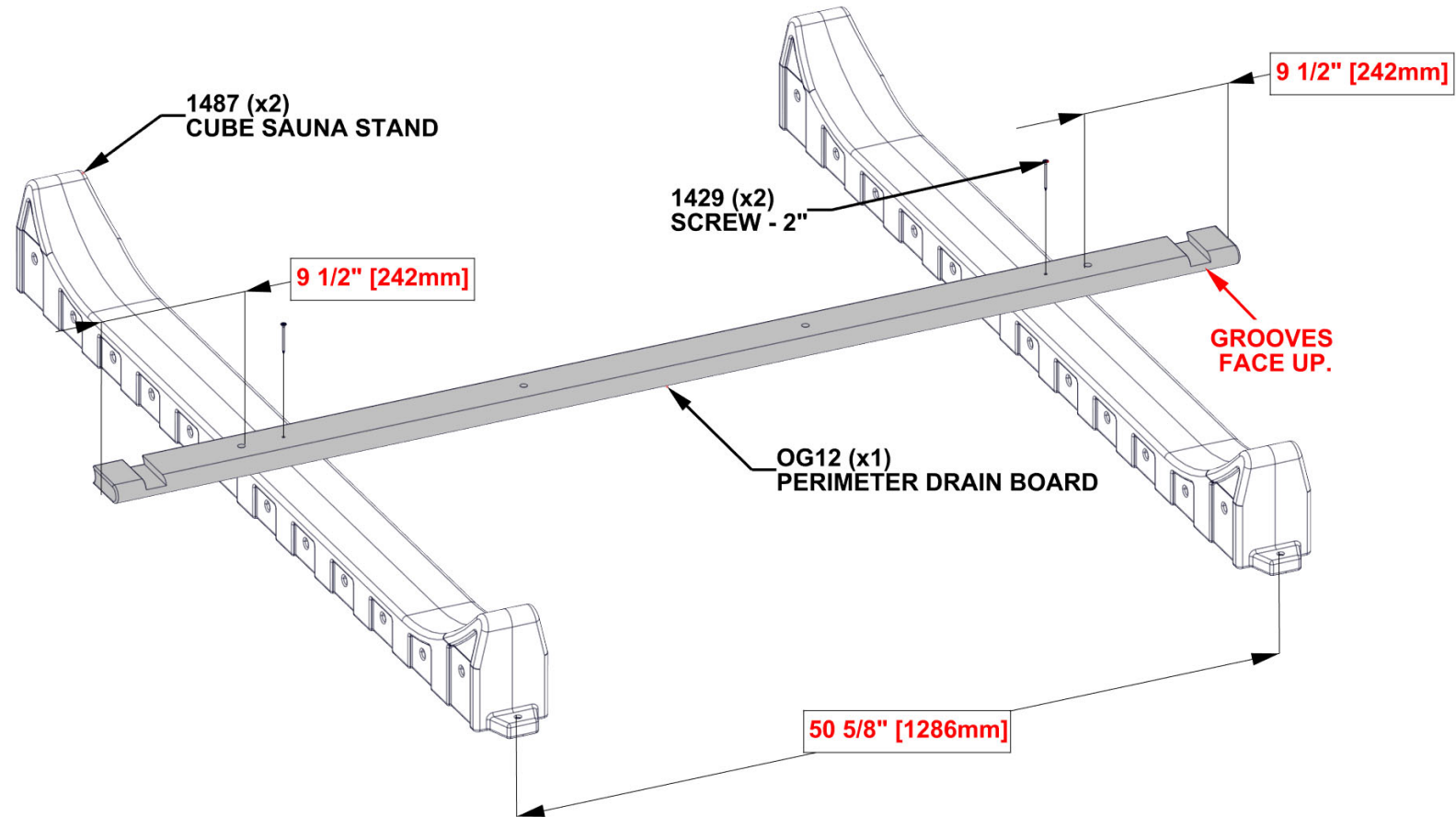
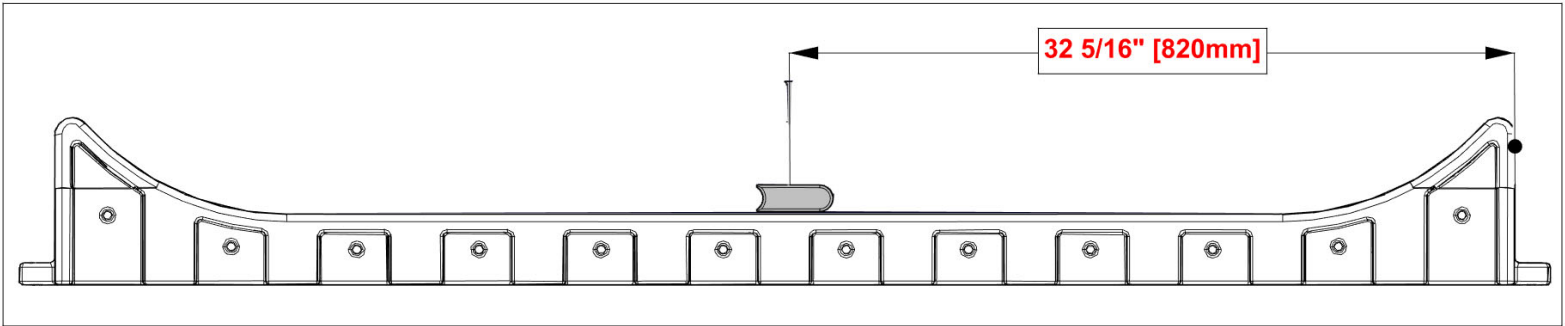

STEP 2 - ANCHORING TO GROUND



- IF SAUNA IS TO SIT ON A CONCRETE SURFACE, SEE STEP 3.

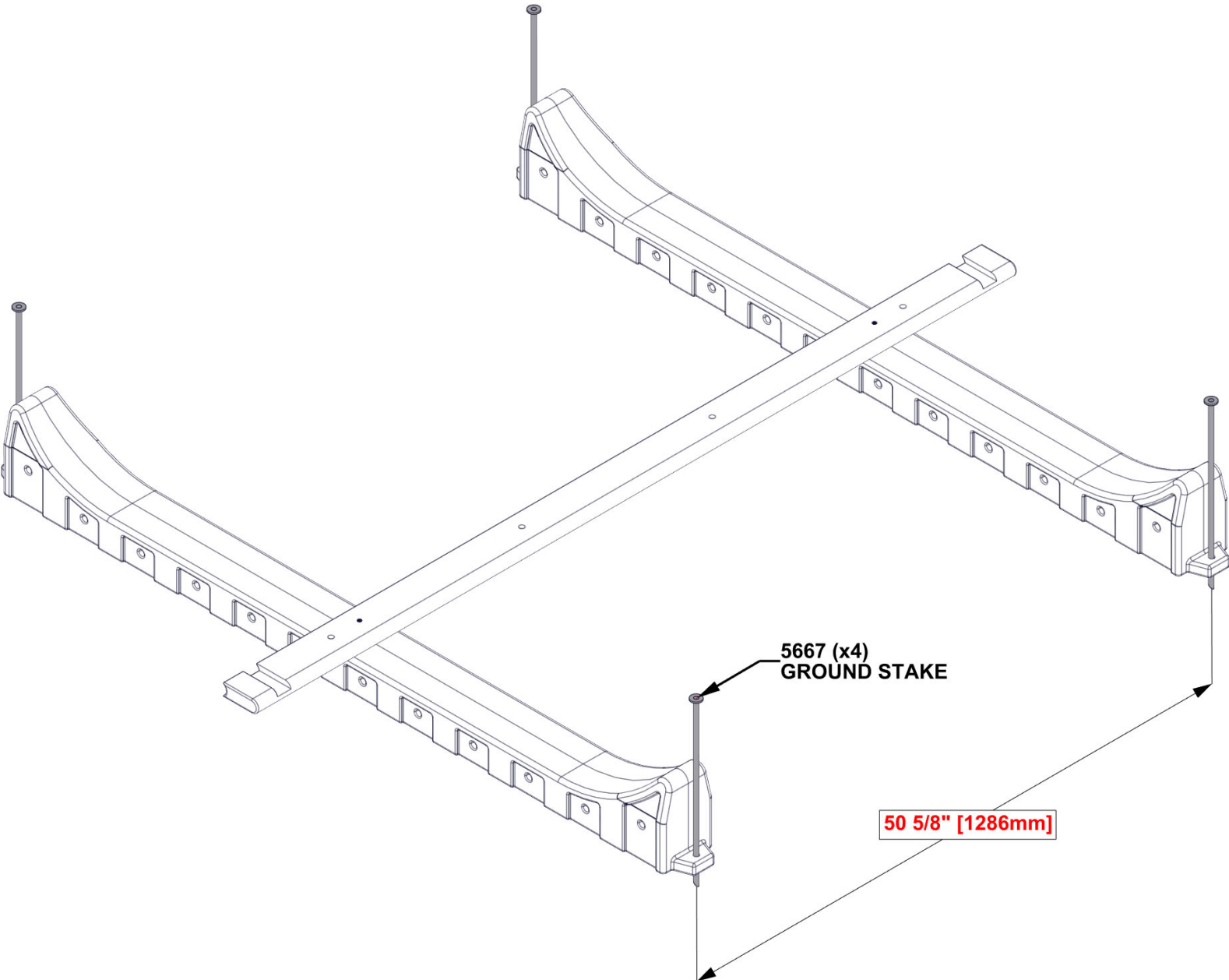

STEP 3 - ANCHORING TO CONCRETE

QTY	PART NUMBER	DESCRIPTION
4	H101165	CONCRETE ANCHOR 3/8x3" BLK

- IF SAUNA IS TO SIT ON THE GROUND, SEE STEP 2.

PRE-DRILL HOLES FOR CONCRETE ANCHORS USING A 5/16" [8mm] CONCRETE DRILL BIT.

1165 (x4)
CONCRETE ANCHOR-3"

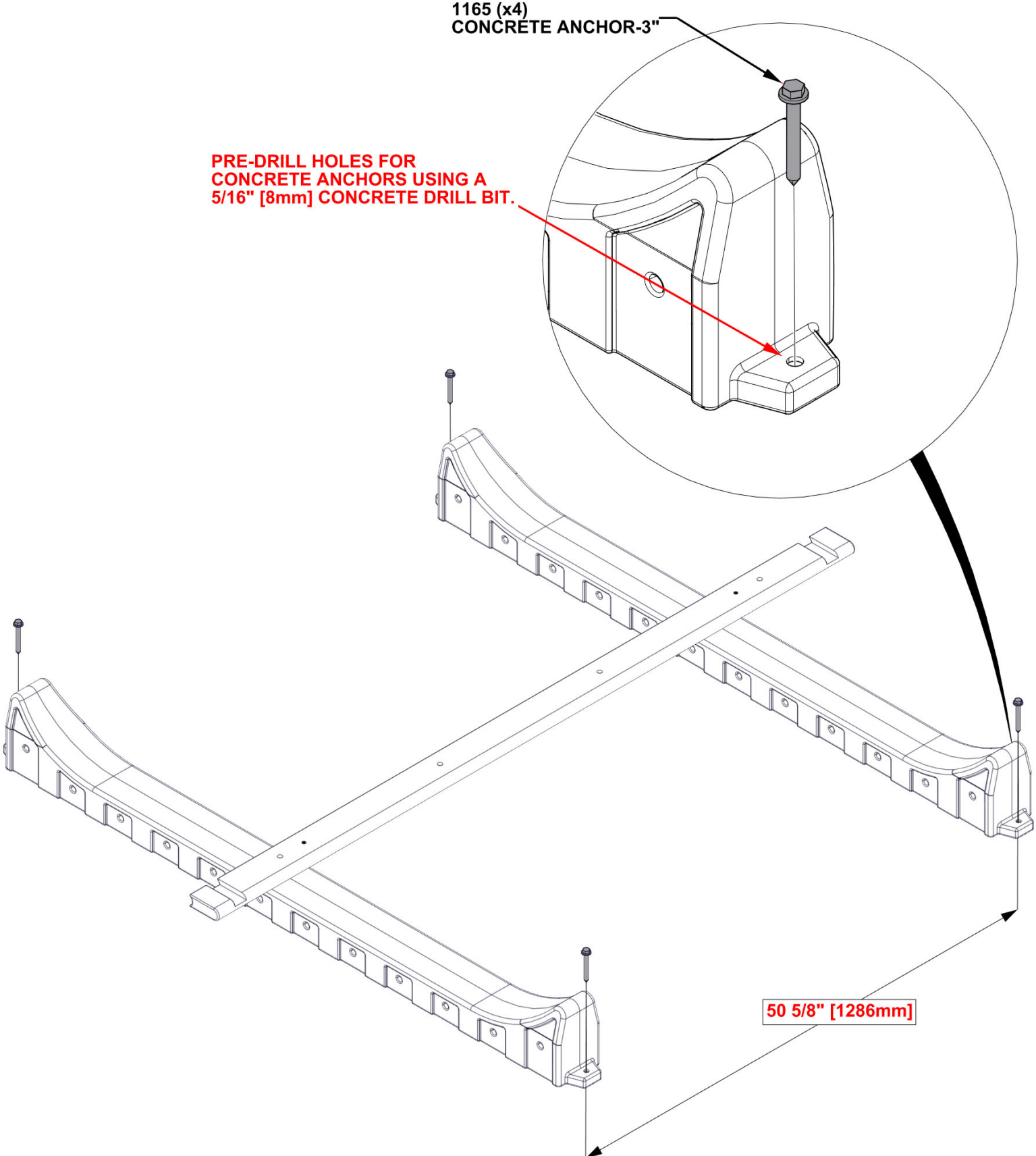

50 5/8" [1286mm]

STEP 4 - BASE ASSEMBLY

QTY	PART NUMBER	DESCRIPTION
40	H101429	SCREW TFH 8X2 SS-BLK

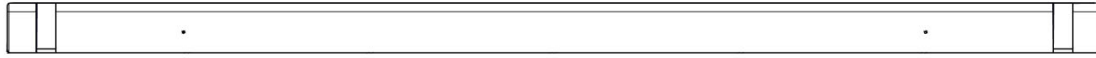

OG13 PERIMETER BOARD - W4L22322
(x20) 1 3/16"x3 3/8"x74 5/8" (30x86x1895)

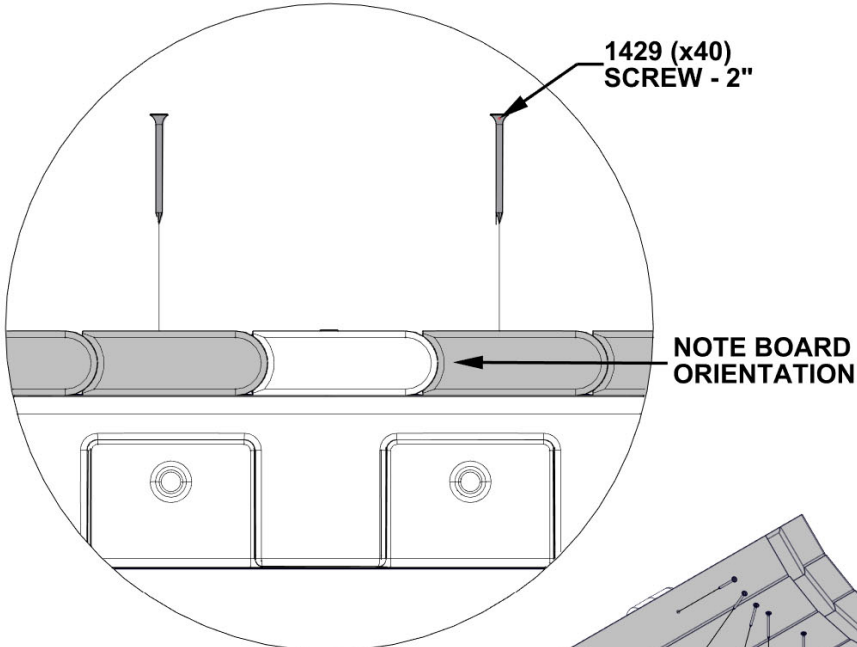

FRONT VIEW

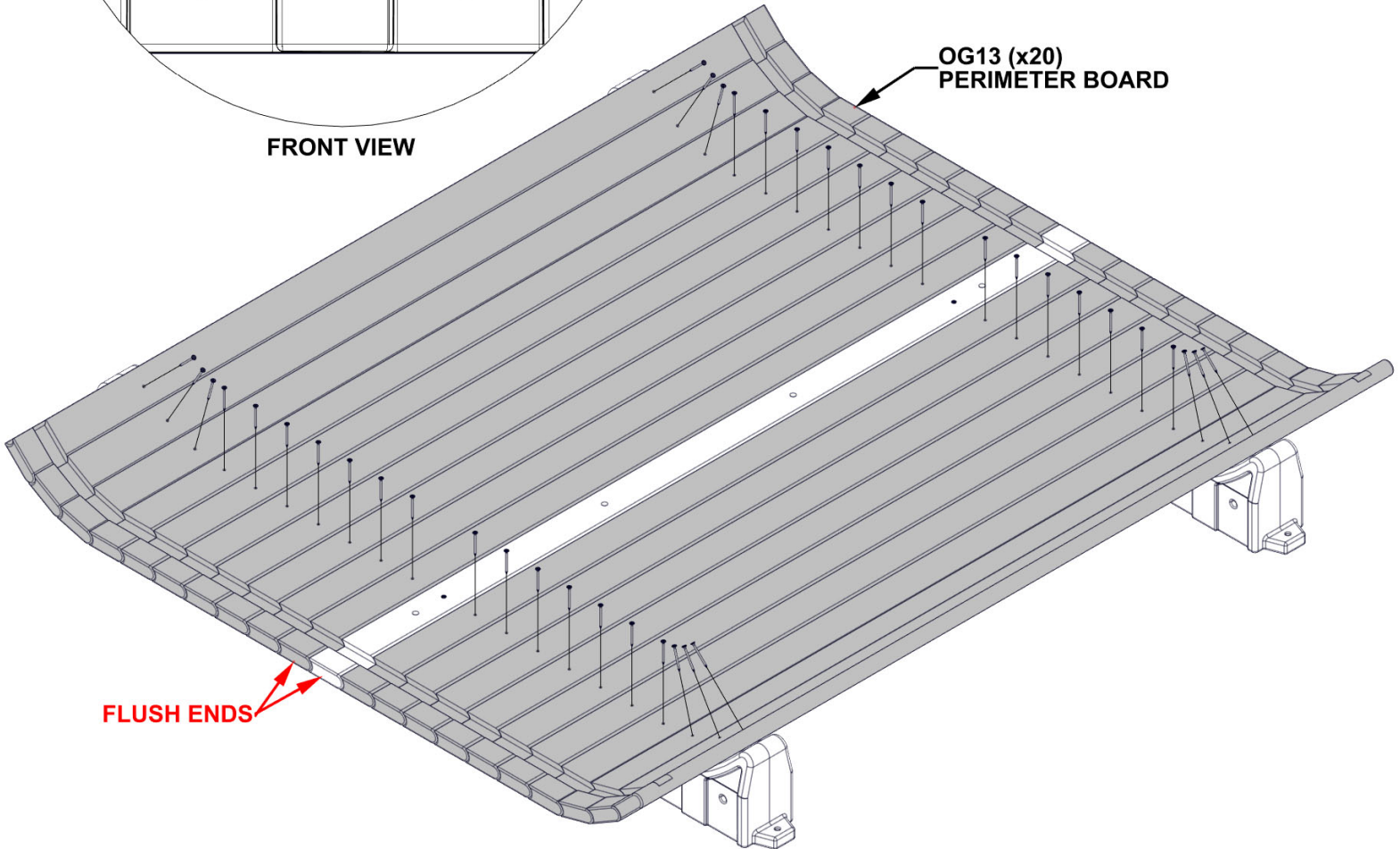

STEP 5 - BACK WALL ASSEMBLY

QTY	PART NUMBER	DESCRIPTION
24	H101429	SCREW TFH 8X2 SS-BLK

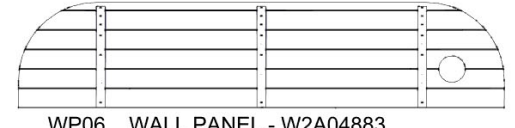
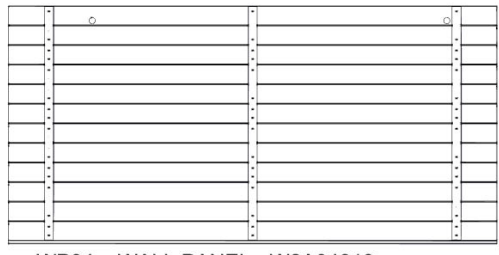
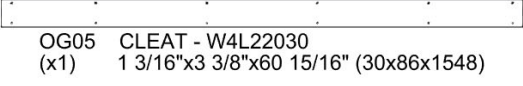

- USING DIMENSIONS SHOWN, CENTER AND ATTACH WALL CLEATS.
- FINISHED PANEL WIDTH SHOULD MEASURE 66 15/16" [1700mm].

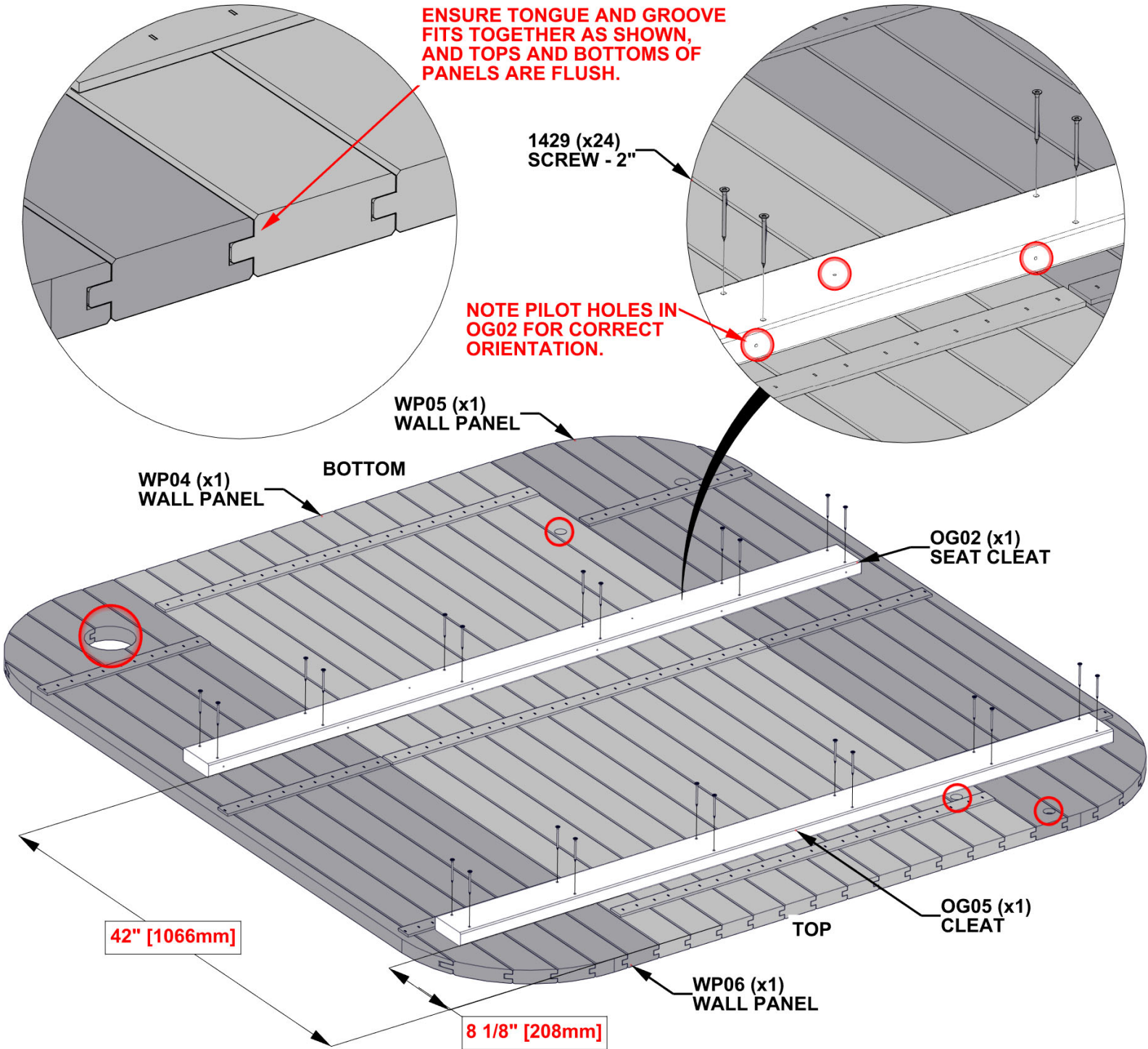

STEP 6 - FRONT WALL ASSEMBLY

QTY	PART NUMBER	DESCRIPTION
32	H101429	SCREW TFH 8X2 SS-BLK

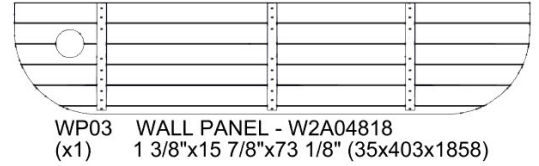
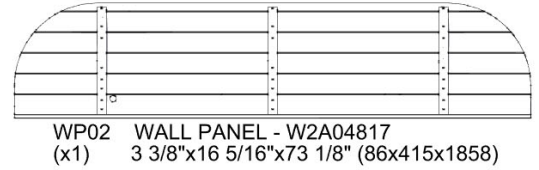
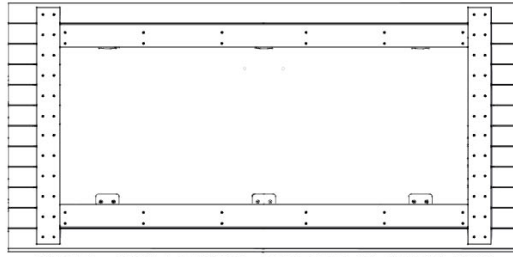
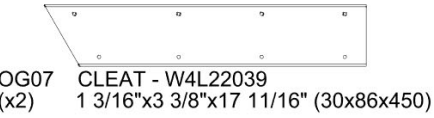
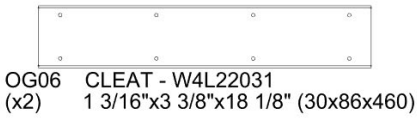

- USE DIMENSIONS SHOWN AND ATTACH CLEATS.
- FINISHED PANEL WIDTH SHOULD MEASURE 66 15/16" [1700mm].
- CAUTION: SUPPORT GLASS DOOR AT ALL TIMES TO PREVENT ACCIDENTAL OPENING AND BREAKAGE.

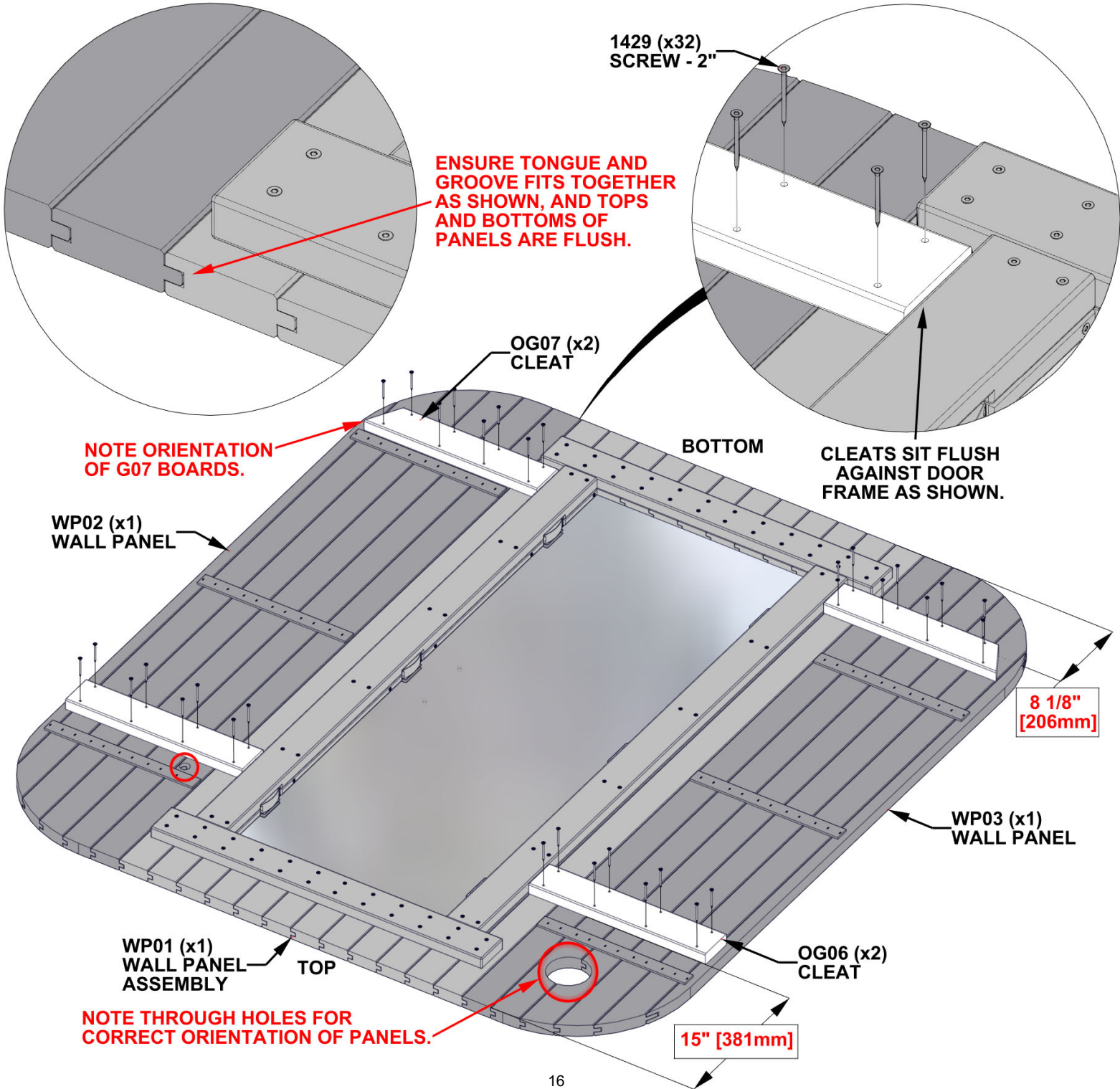

STEP 7 - SAUNA ASSEMBLY

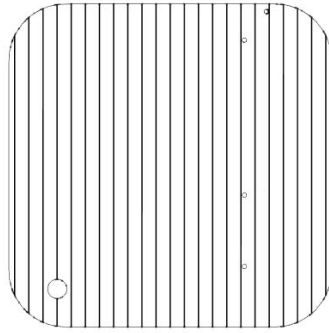

BACK WALL ASSEMBLY - FROM STEP 5

- CAREFULLY LOWER BACK WALL ASSEMBLY INTO THE GROOVES ON THE PERIMETER BOARD/BASE SUPPORT ASSEMBLED IN STEP 4.
- HAVE A SECOND PERSON HOLD THE BACK WALL TO KEEP IT STEADY DURING THE NEXT FEW STEPS.
- **WHEN LIFTING THE WALL ASSEMBLY, LIFT BY THE TOP AND BOTTOM NOT THE SIDES.**

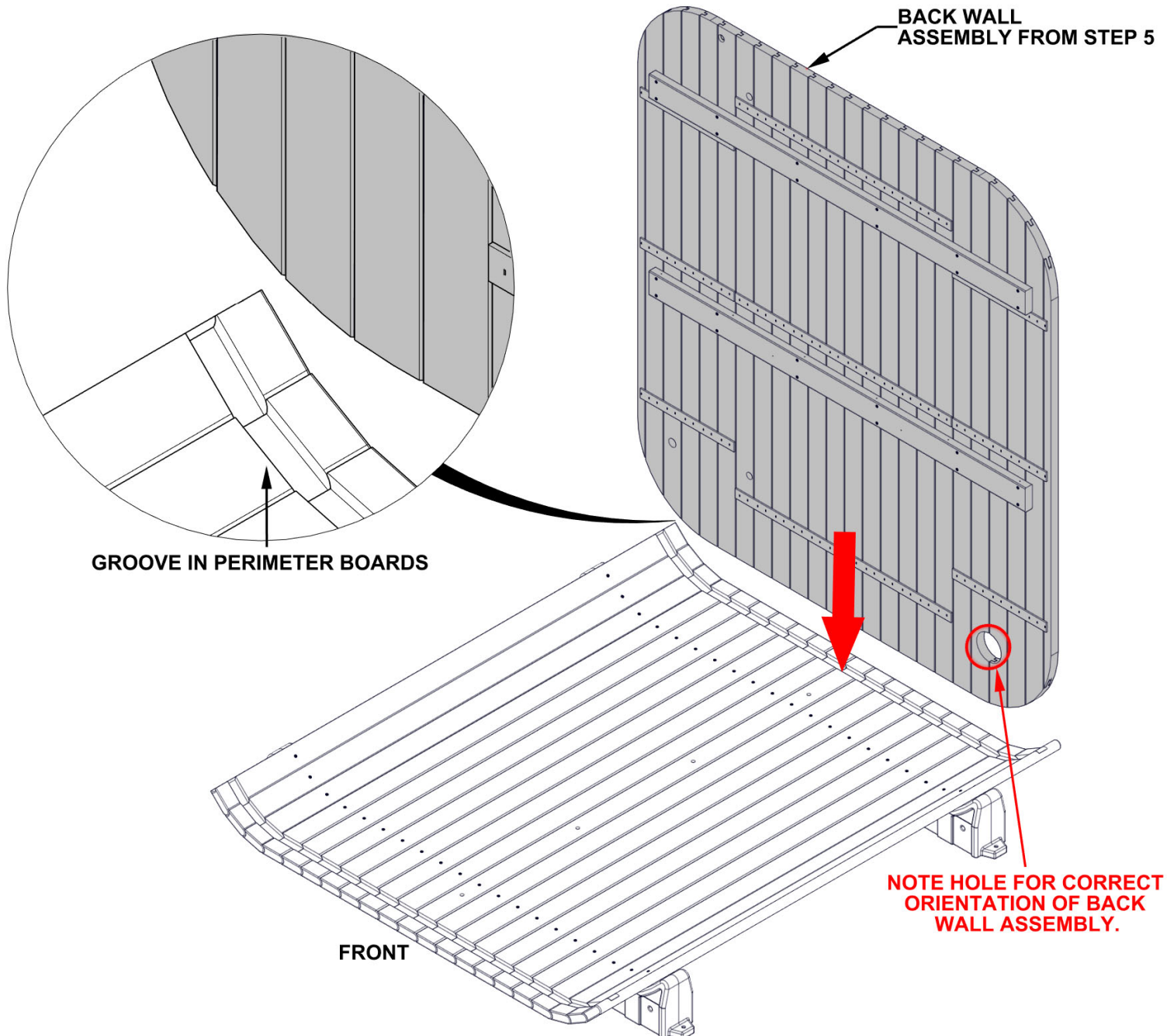

STEP 8 - SAUNA ASSEMBLY

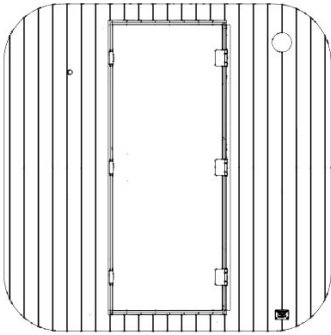

FRONT WALL ASSEMBLY - FROM STEP 6

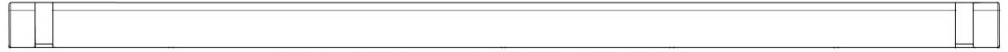

OG01 PERIMETER BOARD - W4L21936
(x1) 1 3/16"x3 3/8"x74 5/8" (30x86x1895)

- CAREFULLY LOWER FRONT WALL ASSEMBLY INTO THE GROOVES ON THE PERIMETER BOARD/BASE SUPPORT ASSEMBLED IN STEP 4.
- POSITION THE PERIMETER BOARD ON THE TOP OF THE WALL ASSEMBLIES TO HOLD THE WALLS IN PLACE.
- WHEN LIFTING WALL ASSEMBLY, LIFT BY TOP AND BOTTOM NOT THE SIDES.
- CAUTION: SUPPORT GLASS DOOR AT ALL TIMES TO PREVENT ACCIDENTAL OPENING AND BREAKAGE.

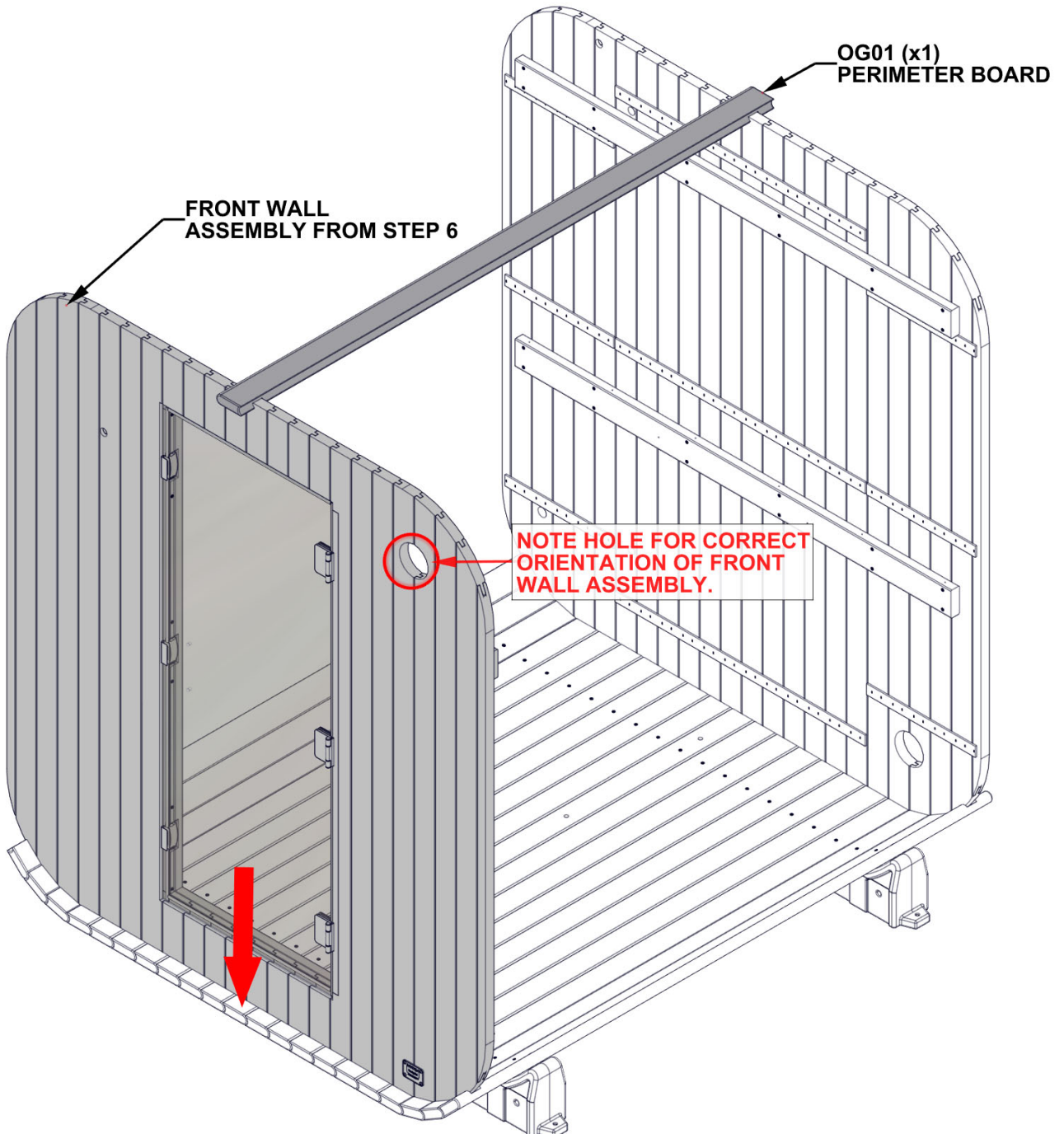

STEP 9 - SAUNA ASSEMBLY

QTY	PART NUMBER	DESCRIPTION
24	H101413	NAIL STD 2.5x50 GLV

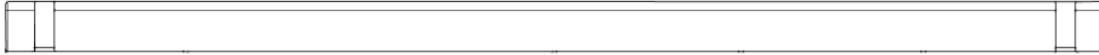

OG01 PERIMETER BOARD - W4L21936
(x22) 1 3/16"x3 3/8"x74 5/8" (30x86x1895)

- ALIGN GROOVE IN PERIMETER BOARDS WITH BOTH FRONT WALL AND BACK WALL ASSEMBLIES.
- WORKING UPWARDS, STACK 11 BOARDS ON EACH SIDE OF THE PERIMETER BOARD/BASE AS SHOWN.
- FASTEN APPROXIMATELY EVERY OTHER PERIMETER BOARD TO THE WALLS WITH H101413 TO HOLD IN PLACE.
- IF YOU HAVE ACCESS TO A PNEUMATIC NAILER, THIS STEP WILL GO FASTER.

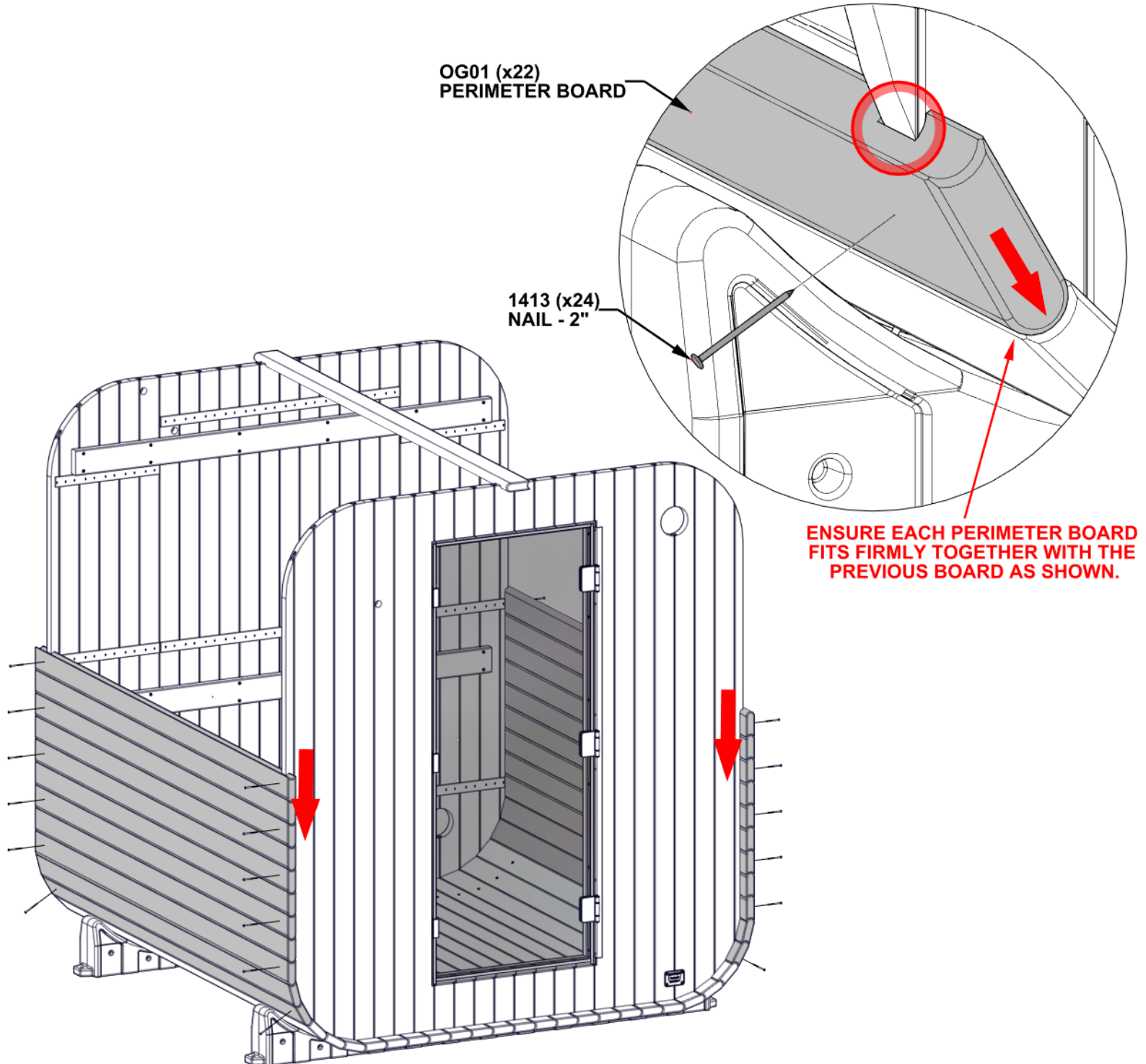

STEP 10 - HANDLE ASSEMBLY

QTY	PART NUMBER	DESCRIPTION
2	H101402	SCREW TFH 1/4-20 X 1 5/8 SS
4	H101403	POLY WASHER

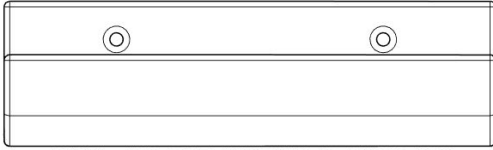

HA01 HANDLE ASSEMBLY - W2A04820
(x1) 2 1/4"x3"x10 3/16" (57x76x258)

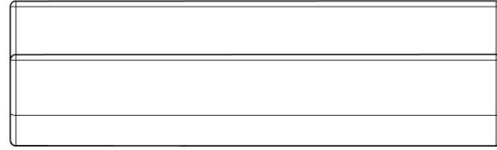

AM01 DOOR HANDLE - W4L21937
(x1) 2 1/4"x3"x10 3/16" (57x76x258)

- ATTACH DOOR HANDLES AS SHOWN.
- DO NOT OVERTIGHTEN.

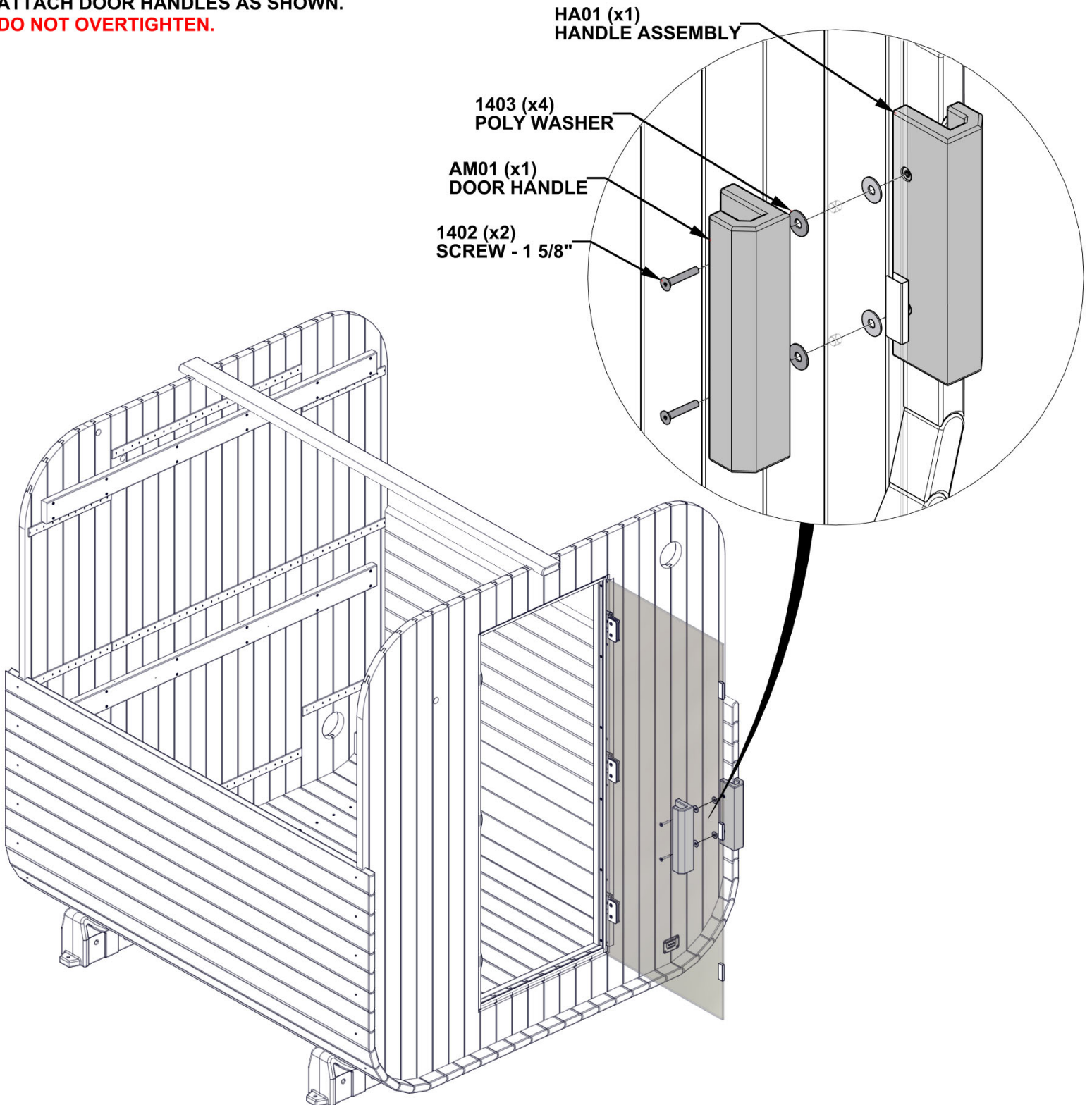

STEP 11 - SAUNA ASSEMBLY

QTY	PART NUMBER	DESCRIPTION
30	H101429	SCREW TFH 8X2 SS-BLK



OO05 FLOOR CLEAT - W4L22600
(x2) 1 3/16"x1 3/16"x45 1/4" (30x30x1150)

- CENTER FLOOR CLEATS FROM SIDE TO SIDE AND ATTACH USING MEASUREMENTS SHOWN.
- CHECK MEASUREMENTS AT BOTH ENDS OF CLEATS TO ENSURE THEY ARE PARALLEL WITH THE BACK WALL.

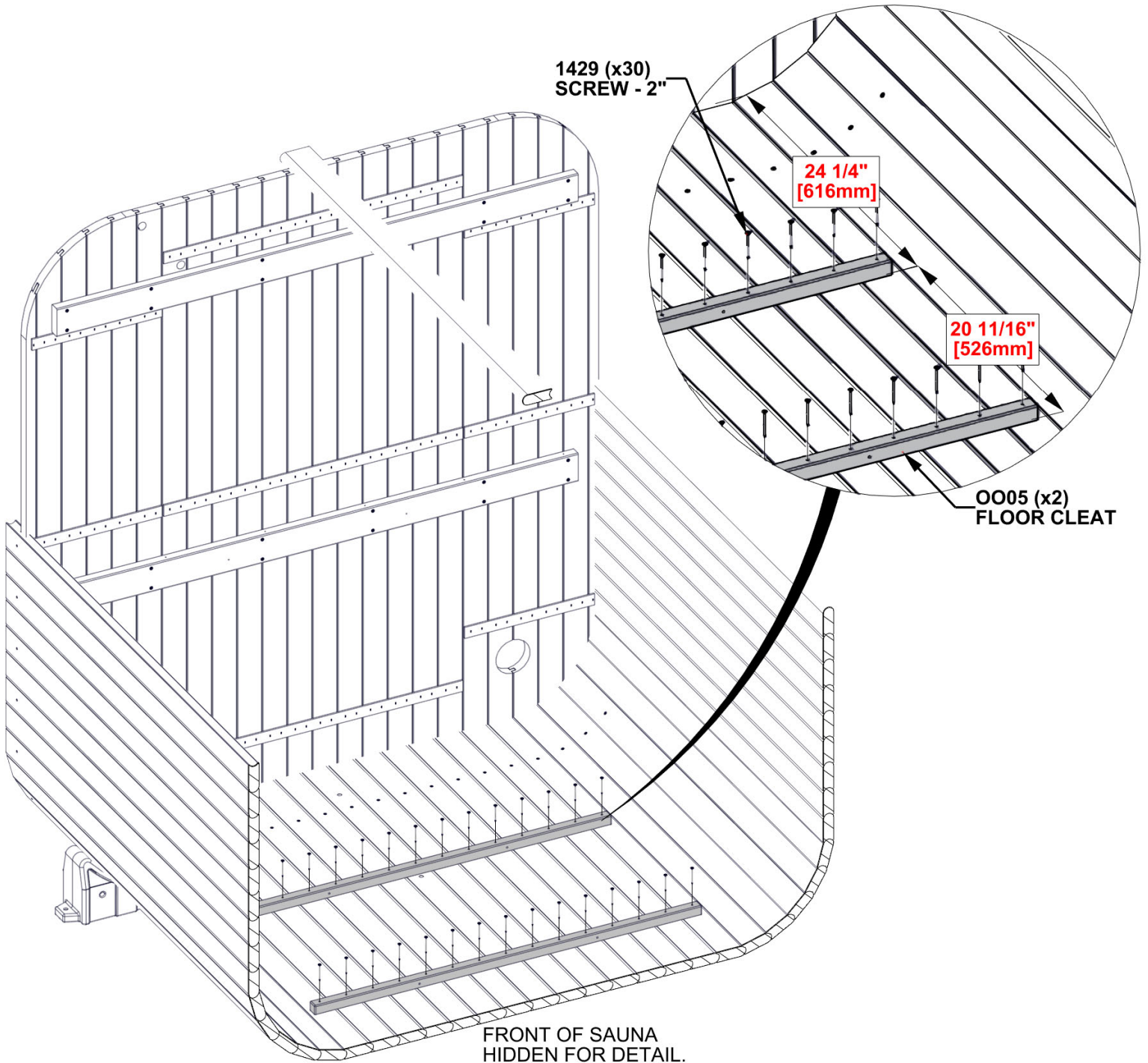

FRONT OF SAUNA
HIDDEN FOR DETAIL.

STEP 12 - BENCH ASSEMBLY

QTY	PART NUMBER	DESCRIPTION
12	H101429	SCREW TFH 8X2 SS-BLK

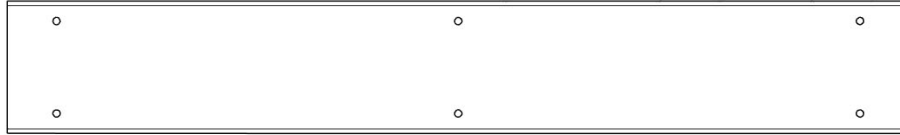

OG04 SEAT CLEAT - W4L21951
(x2) 1 3/16"x3 3/8"x23 1/16" (30x86x586)

- NOTE PILOT HOLES ON SEAT CLEATS FOR CORRECT ORIENTATION.
- BUTT END OF SEAT CLEATS AGAINST BACK WALL.
- ENSURE TOPS OF SEAT CLEATS ARE FLUSH WITH CLEAT ON BACK WALL AND LEVEL.
- ATTACH BOARDS AS SHOWN.

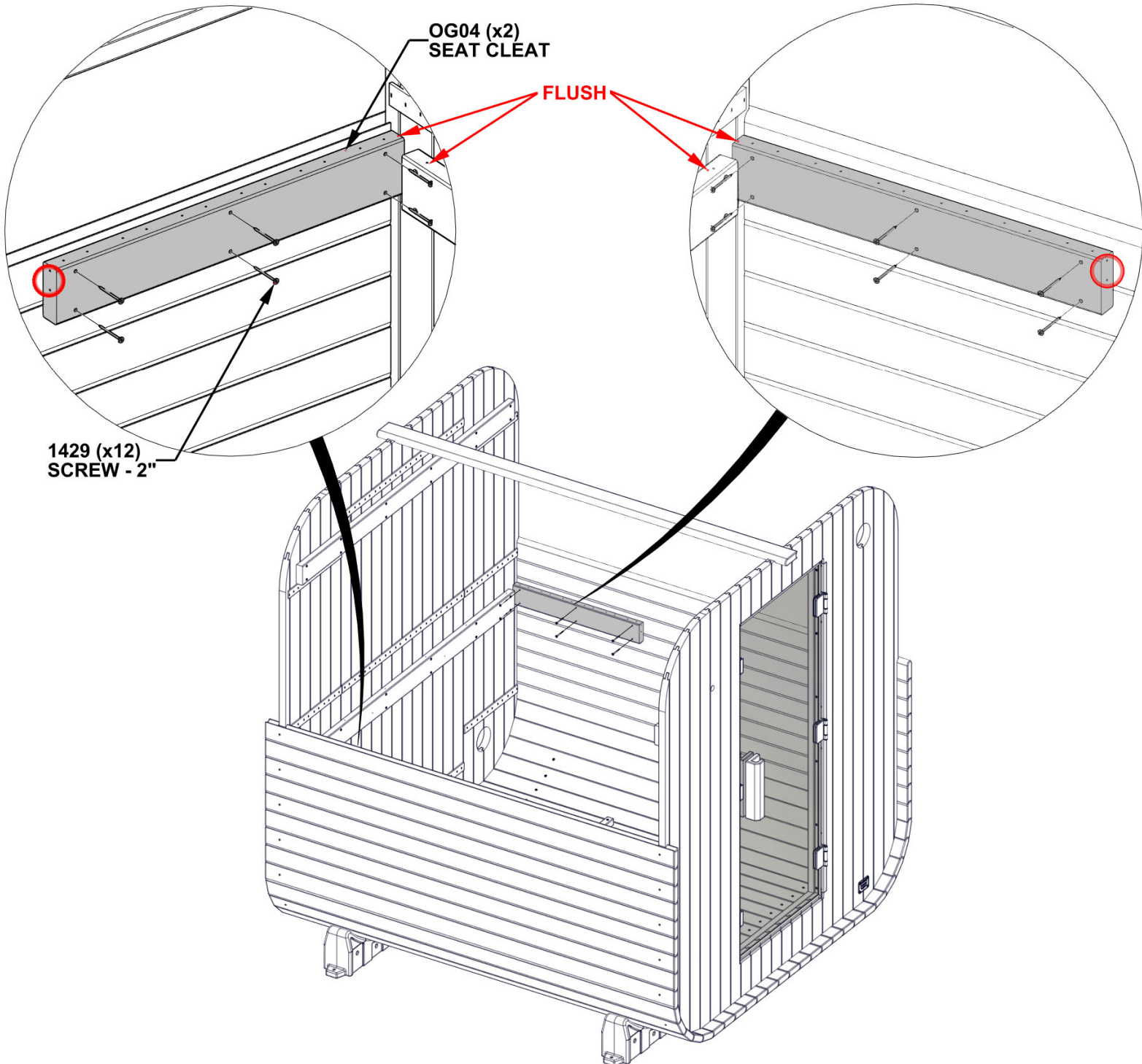

STEP 13 - BENCH ASSEMBLY

QTY	PART NUMBER	DESCRIPTION
4	H101431	SCREW TFH 8X2 1/2 SS-BLK
8	H101443	SCREW TWH 8x1 1/2 SS-BLK

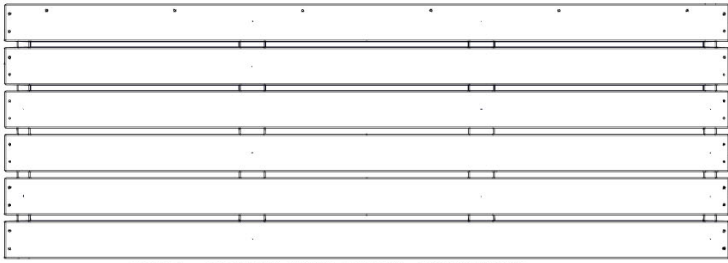

BA01 BENCH ASSEMBLY - W2A04821
(x1) 1 15/16"x23 1/16"x65 3/4" (50x586x1670)



OR01 SEAT UPRIGHT - W4L21945
(x2) 1 3/16"x2 3/8"x30 11/16" (30x60x780)



OR02 ANGLE BRACE - W4L21946
(x2) 1 3/16"x2 3/8"x10 7/8" (30x60x276)

- ALIGN PILOT HOLES AND ATTACH SEAT UPRIGHT TO BENCH ASSEMBLY AS SHOWN.
- THEN ALIGN PILOT HOLES IN ANGLE BRACE WITH PILOT HOLES IN SEAT UPRIGHT AND BENCH ASSEMBLY AND ATTACH.

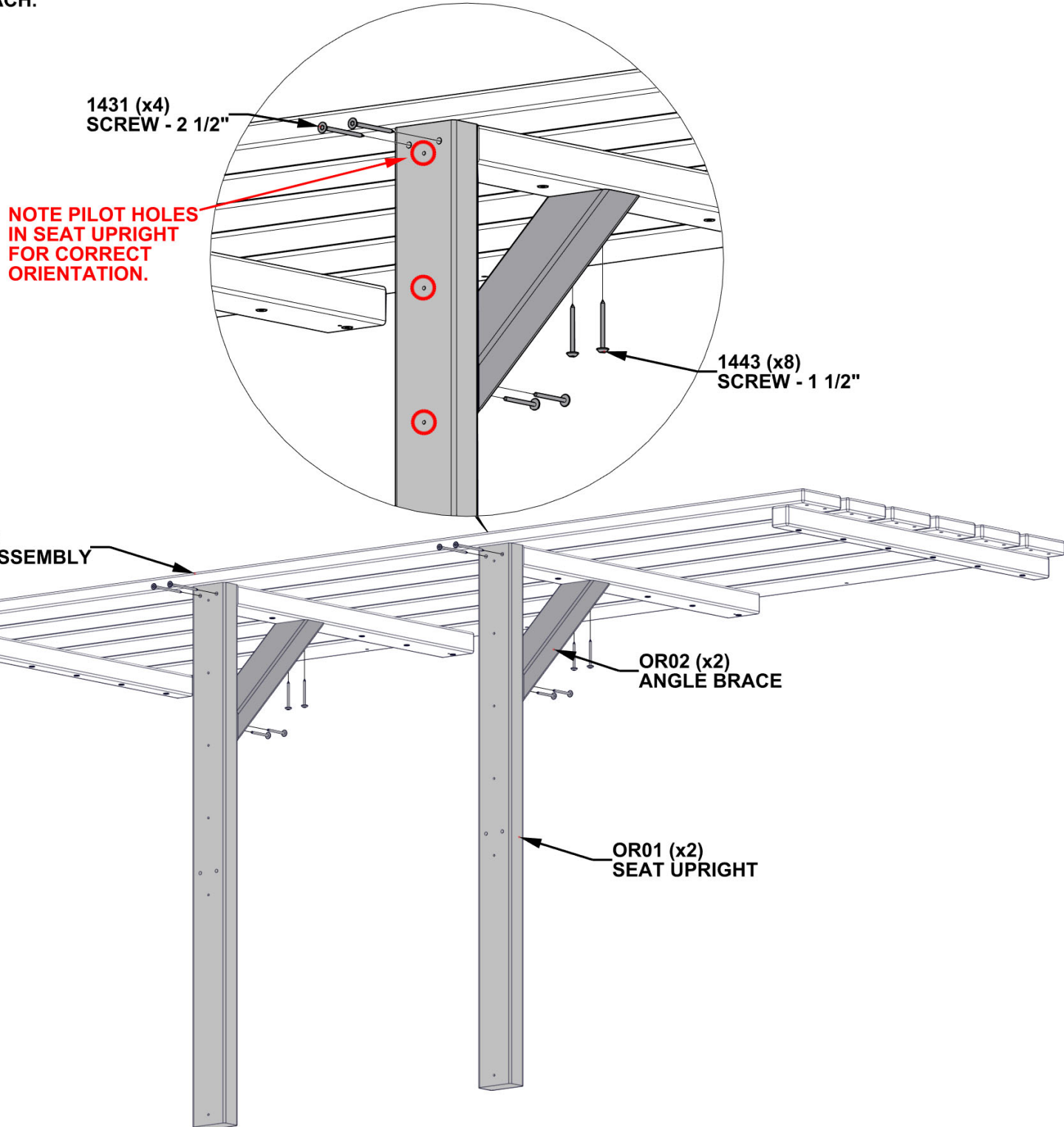

STEP 14 - BENCH ASSEMBLY

QTY	PART NUMBER	DESCRIPTION
30	H101428	SCREW TFH 8X1 3/4 SS-BLK

- ALIGN THROUGH HOLES IN BENCH ASSEMBLY WITH PILOT HOLES IN SEAT CLEATS AND ATTACH AS SHOWN.

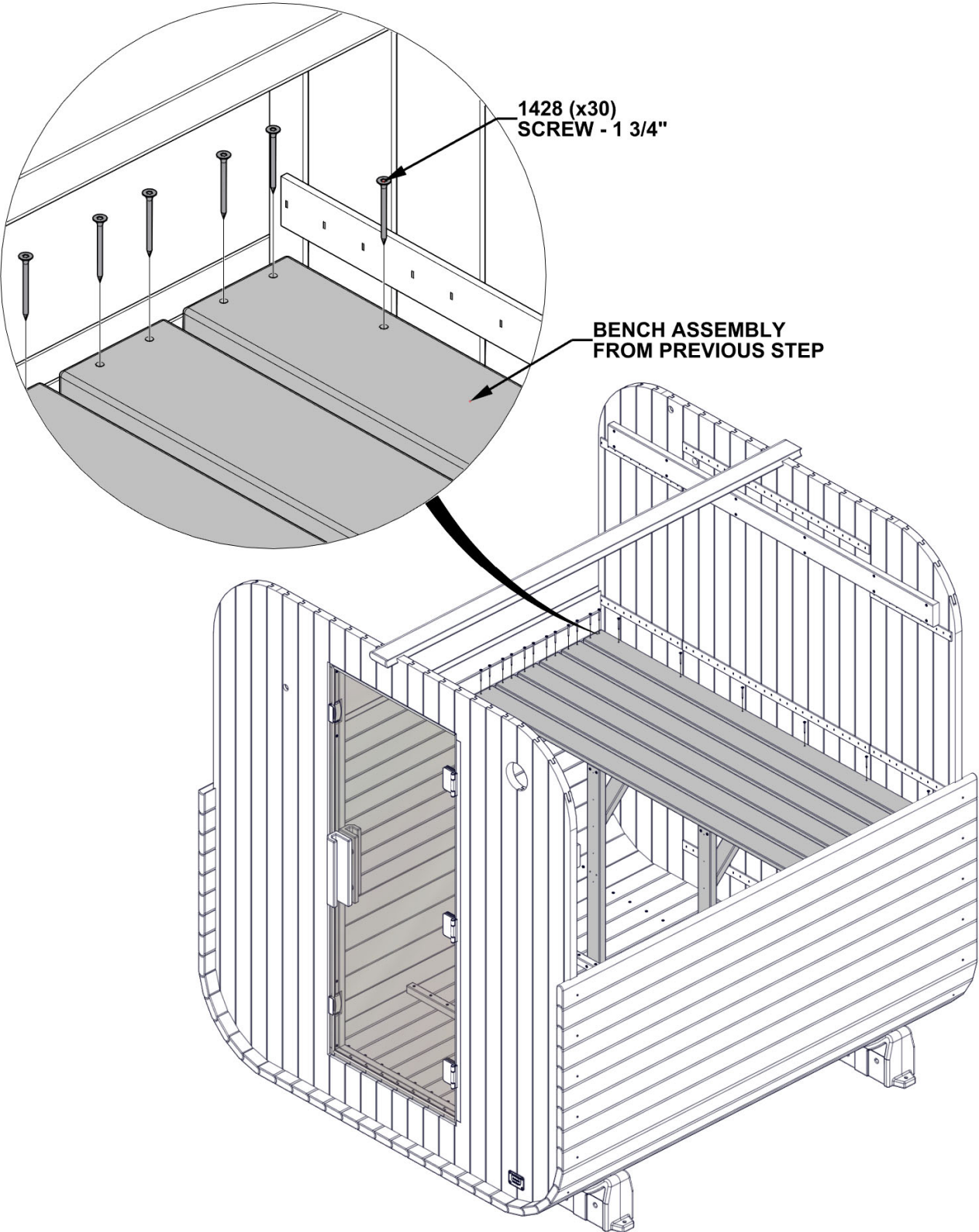

STEP 15 - SAUNA ASSEMBLY

QTY	PART NUMBER	DESCRIPTION
4	H101438	SCREW TWH 8x3/4 SS-BLK

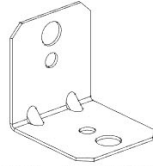

A4M00555 L BRACKET BLK
(x2)

- ALIGN BRACKETS WITH PILOT HOLES AND ATTACH AS SHOWN.

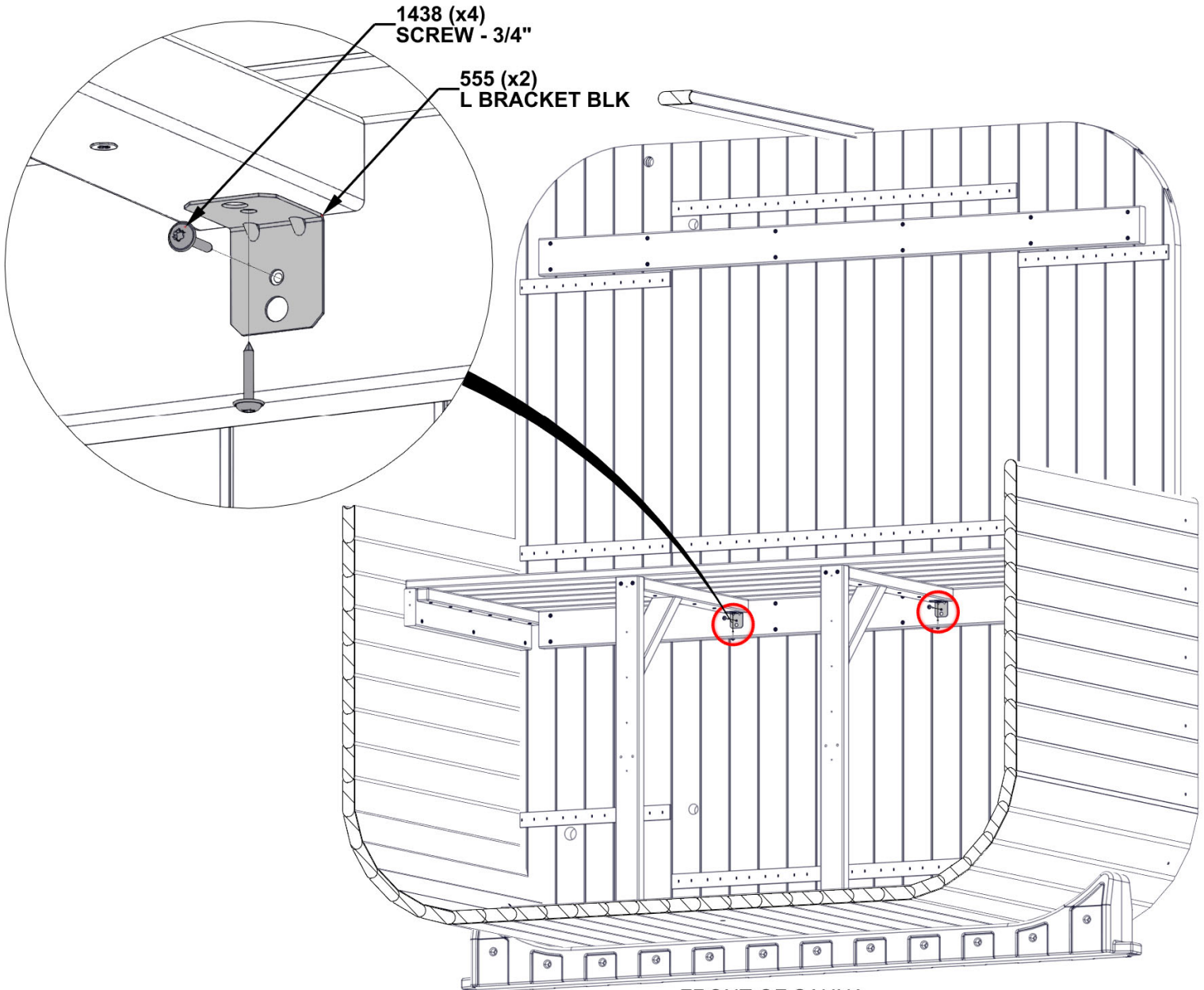

FRONT OF SAUNA
HIDDEN FOR DETAIL.

STEP 16 - SAUNA ASSEMBLY

QTY	PART NUMBER	DESCRIPTION
2	H101429	SCREW TFH 8X2 SS-BLK

- INSERT SCREWS INTO THROUGH HOLES IN PREVIOUSLY INSTALLED FLOOR CLEAT AS SHOWN.

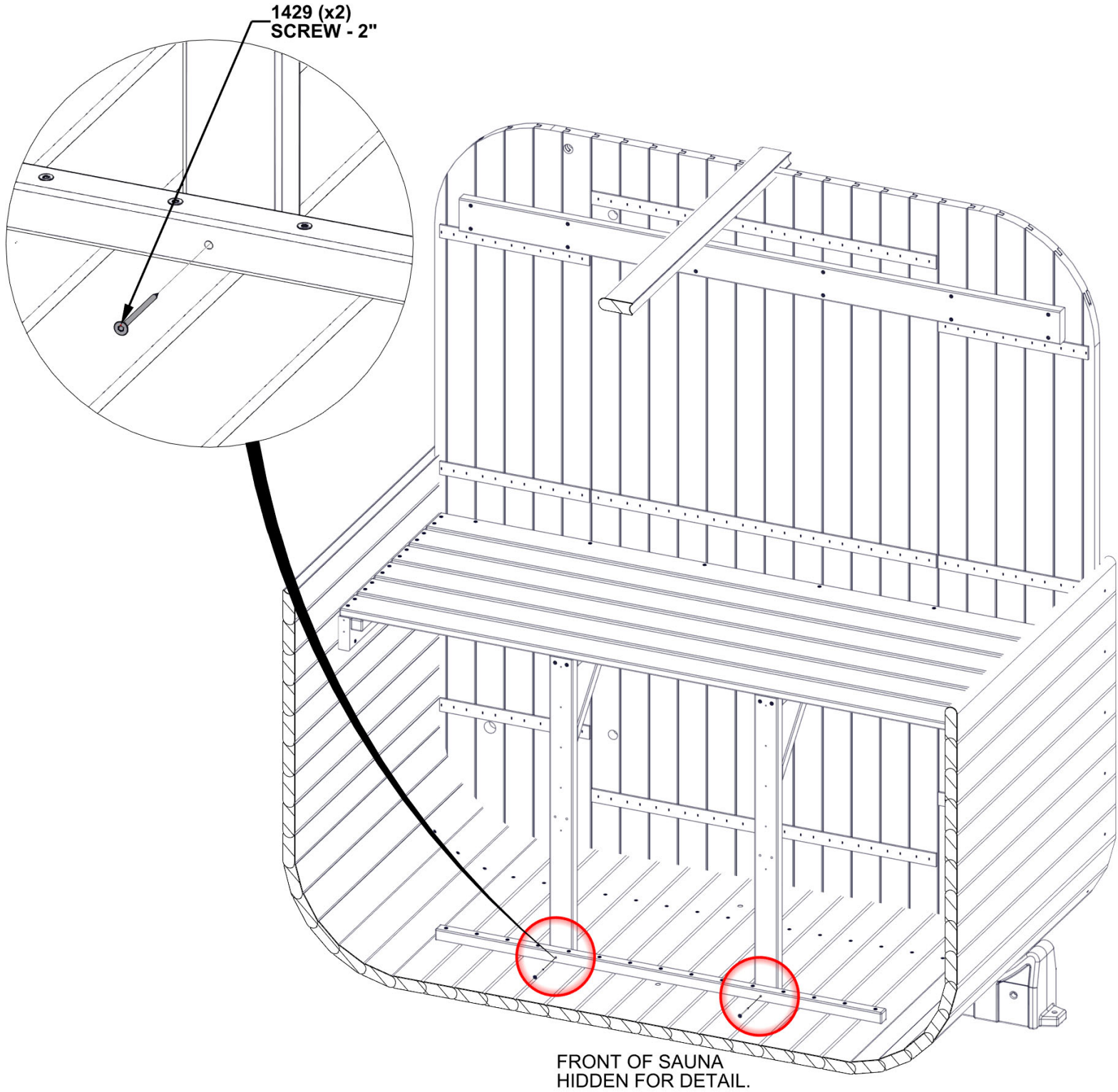

STEP 17 - BENCH ASSEMBLY

QTY	PART NUMBER	DESCRIPTION
4	H101429	SCREW TFH 8X2 SS-BLK



OO01 SLAT CLEAT - W4L21950
(x2) 1 3/16"x1 3/16"x14 15/16" (30x30x380)



OG03 SEAT CLEAT - W4L21944
(x2) 1 3/16"x3 3/8"x23 1/16" (30x86x586)

- NOTE PILOT HOLES IN BOARDS FOR CORRECT ORIENTATION.
- ATTACH AS SHOWN.
- REPEAT THIS STEP TWICE.

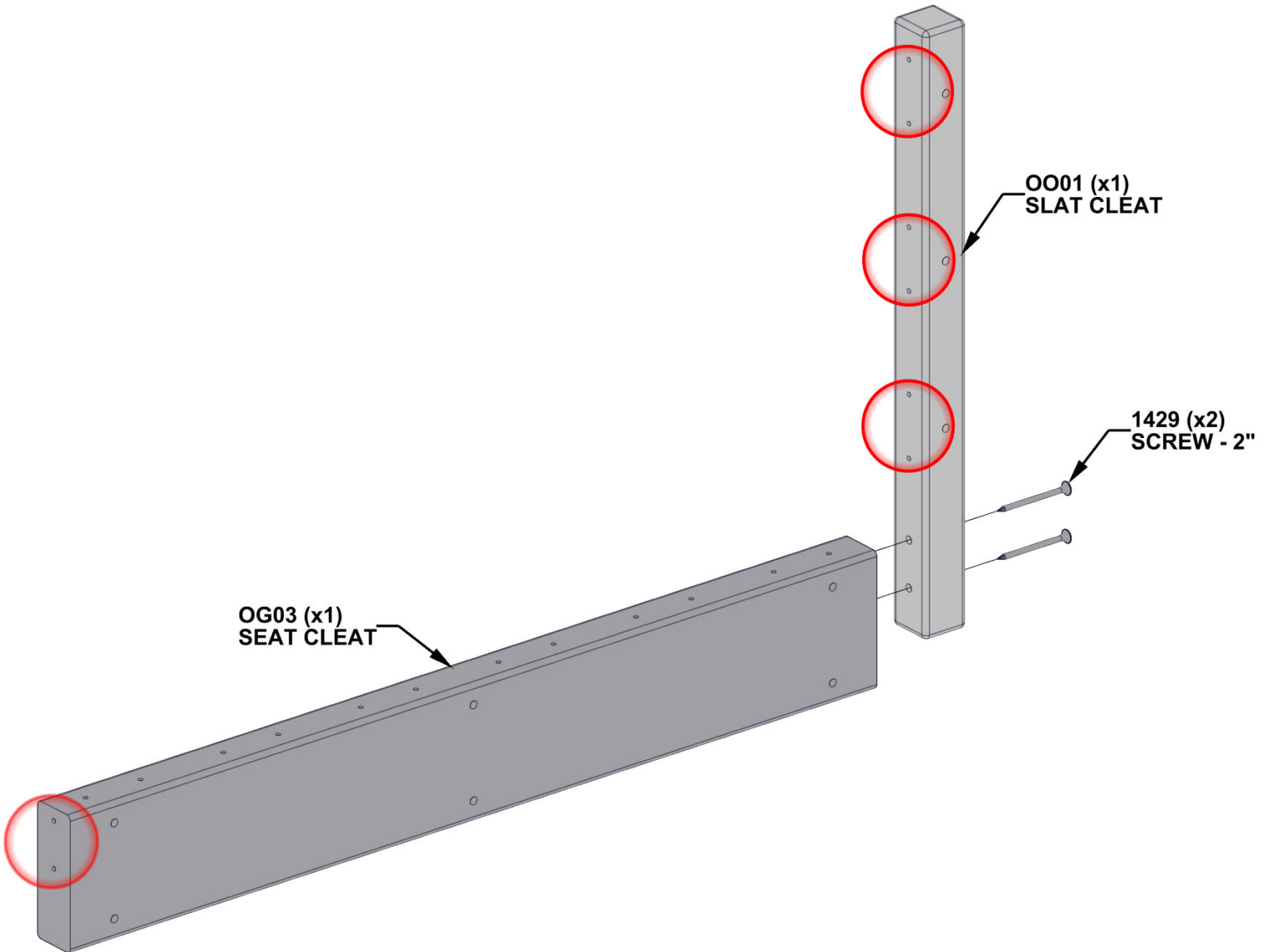

STEP 18 - BENCH ASSEMBLY

QTY	PART NUMBER	DESCRIPTION
18	H101429	SCREW TFH 8X2 SS-BLK

- BUTT TOP OF CLEAT ASSEMBLY AGAINST EXISTING CLEAT AS SHOWN.
- ENSURE FRONT OF SEAT CLEAT IS FLUSH WITH END OF EXISTING CLEAT.
- ENSURE SEAT CLEAT IS LEVEL.
- ATTACH AS SHOWN.

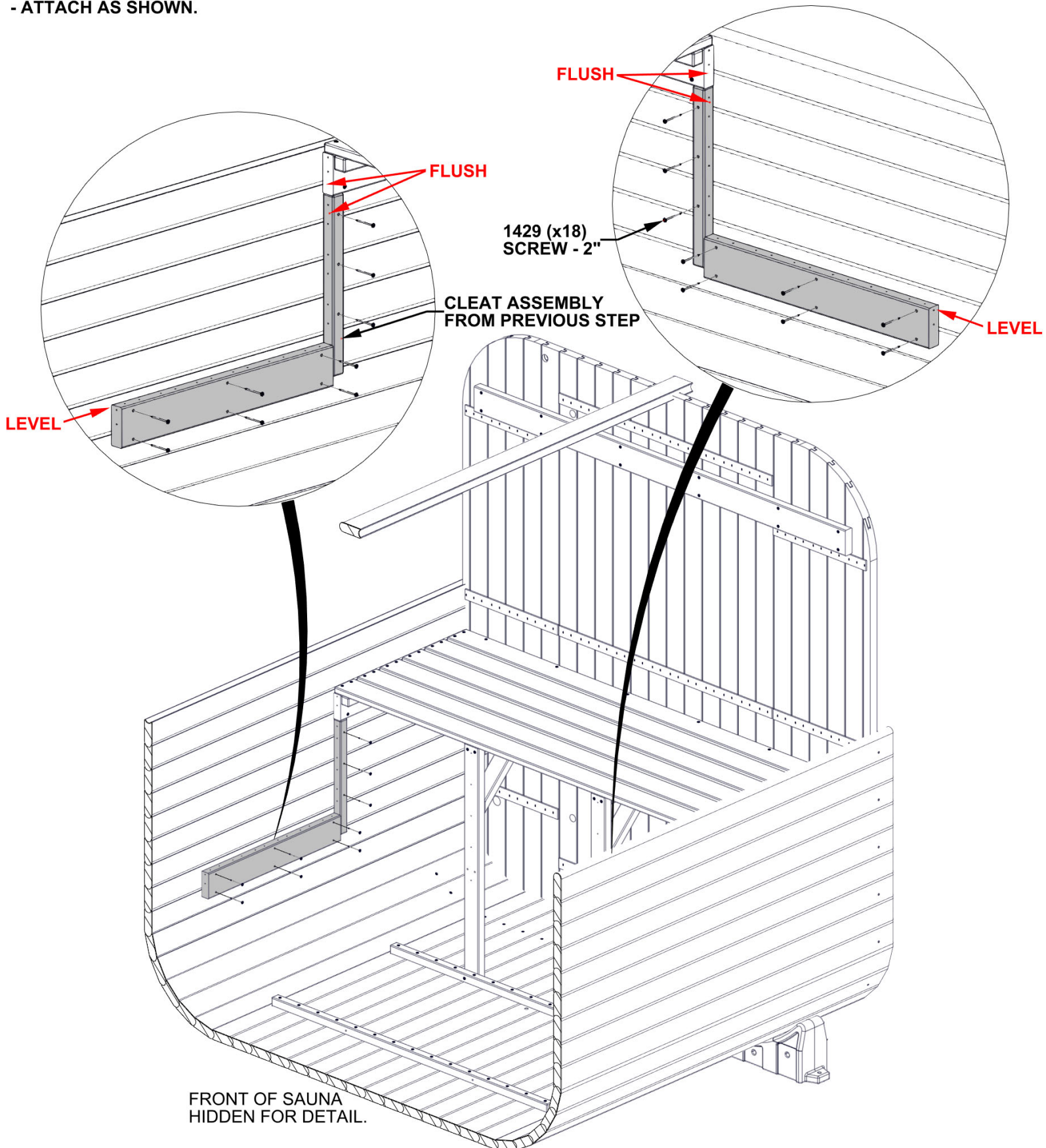

STEP 19 - BENCH ASSEMBLY

QTY	PART NUMBER	DESCRIPTION
4	H101431	SCREW TFH 8X2 1/2 SS-BLK
8	H101443	SCREW TWH 8x1 1/2 SS-BLK

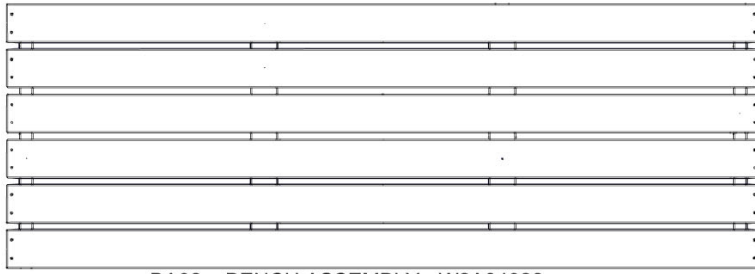

BA02 BENCH ASSEMBLY - W2A04822
(x1) 1 15/16"x23 1/16"x65 3/4" (50x586x1670)



OR02 ANGLE BRACE - W4L21946
(x2) 1 3/16"x2 3/8"x10 7/8" (30x60x276)

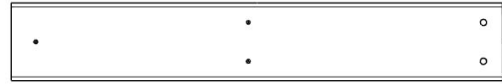

OR03 SEAT UPRIGHT - W4L21947
(x2) 1 3/16"x2 3/8"x14 15/16" (30x60x380)

- ALIGN PILOT HOLES AND ATTACH SEAT UPRIGHT TO BENCH ASSEMBLY AS SHOWN.
- THEN ALIGN PILOT HOLES IN ANGLE BRACE WITH PILOT HOLES IN SEAT UPRIGHT AND BENCH ASSEMBLY AND ATTACH.

1431 (x4)
SCREW - 2 1/2"

**NOTE PILOT HOLES
IN SEAT UPRIGHT
FOR CORRECT
ORIENTATION.**

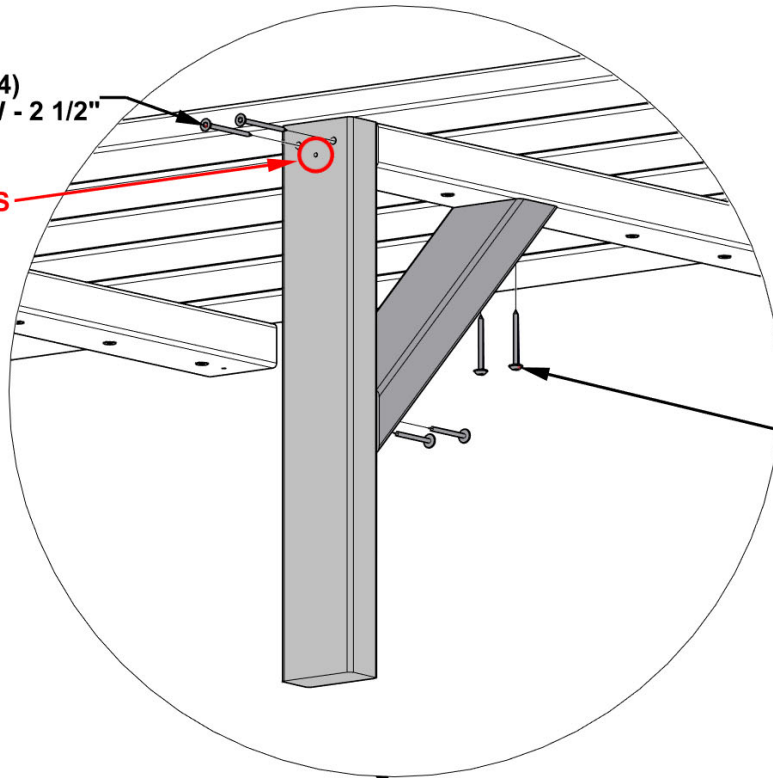

1443 (x8)
SCREW - 1 1/2"

BA02 (x1)
BENCH ASSEMBLY

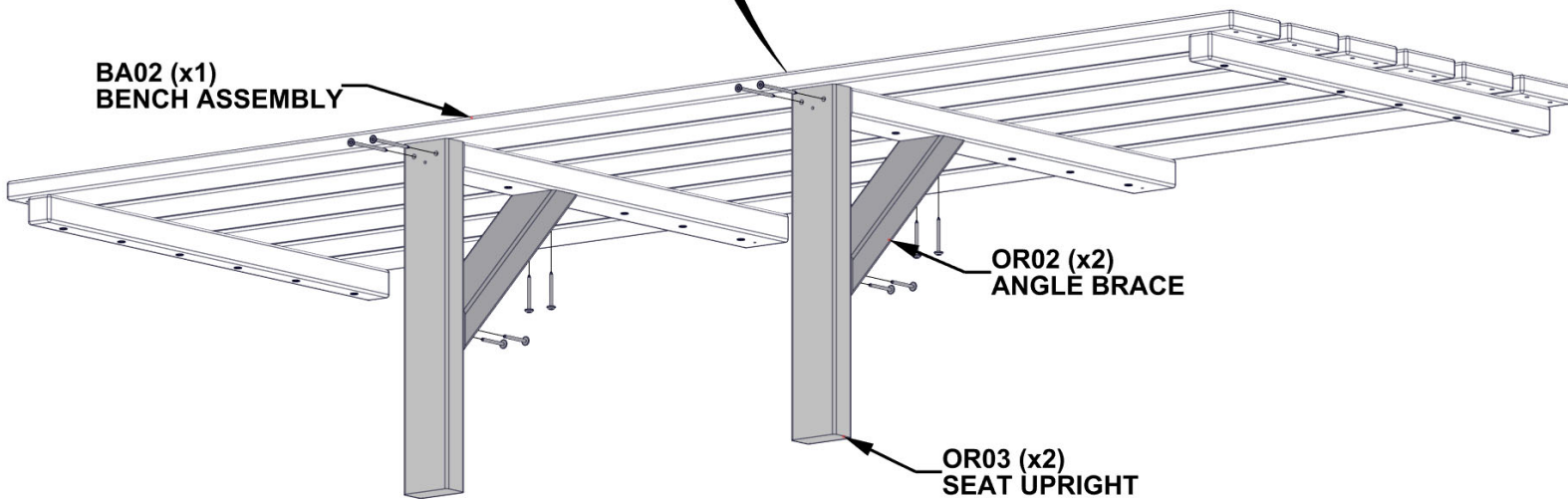

OR02 (x2)
ANGLE BRACE

OR03 (x2)
SEAT UPRIGHT

STEP 20 - BENCH ASSEMBLY

QTY	PART NUMBER	DESCRIPTION
24	H101428	SCREW TFH 8X1 3/4 SS-BLK
4	H101431	SCREW TFH 8X2 1/2 SS-BLK

- ALIGN THROUGH HOLES IN BENCH ASSEMBLY WITH PILOT HOLES IN SEAT CLEATS AND ATTACH AS SHOWN.
- ALIGN THROUGH HOLES IN PREVIOUSLY INSTALLED UPRIGHTS WITH PILOT HOLES IN BENCH ASSEMBLY.

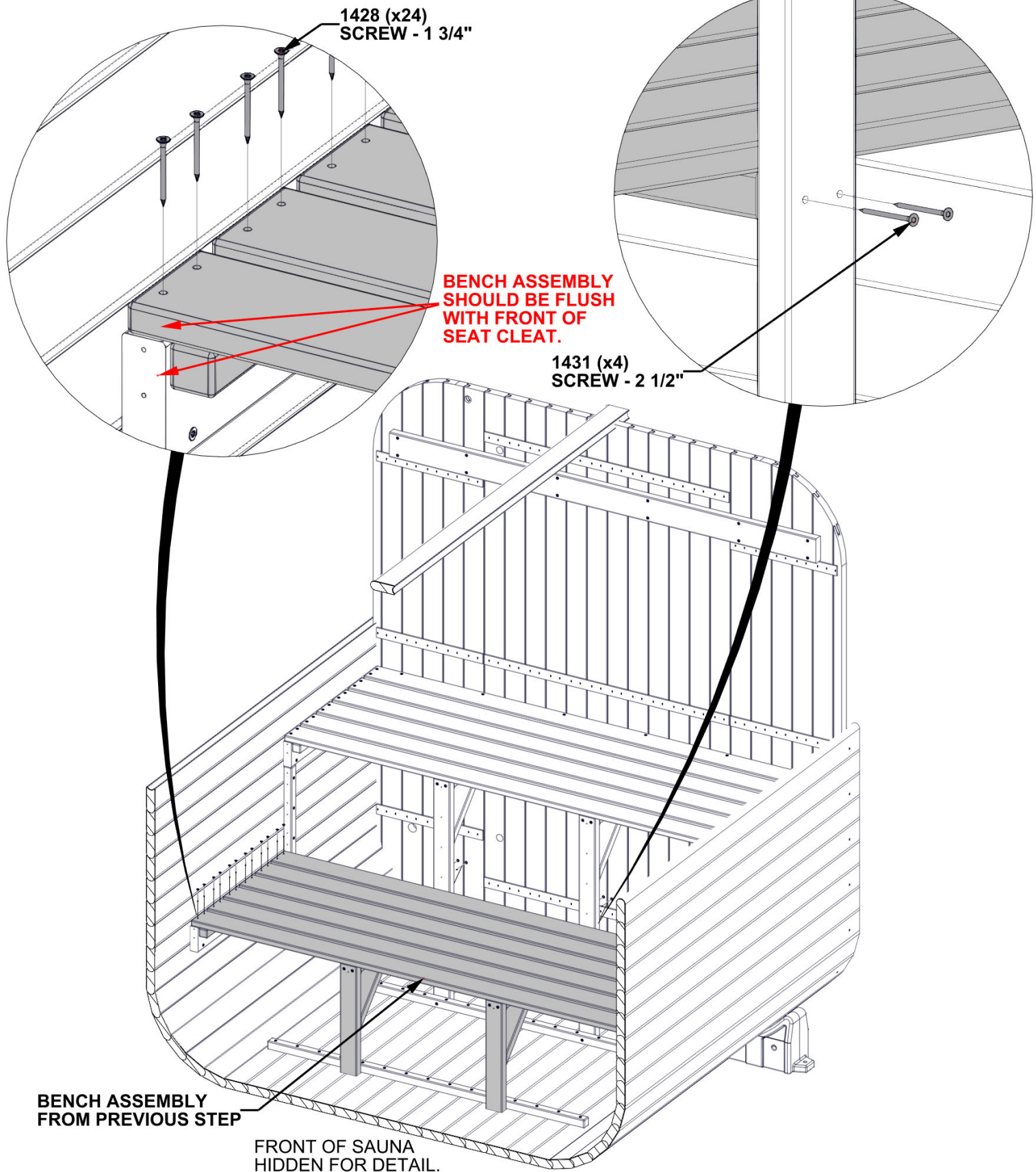

BENCH ASSEMBLY FROM PREVIOUS STEP

FRONT OF SAUNA HIDDEN FOR DETAIL.

STEP 21 - BENCH ASSEMBLY

QTY	PART NUMBER	DESCRIPTION
4	H101438	SCREW TWH 8x3/4 SS-BLK

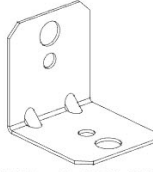

A4M00555 L BRACKET BLK
(x2)

- ALIGN BRACKETS WITH PILOT HOLES IN BACKS OF UPRIGHTS AND ATTACH AS SHOWN.

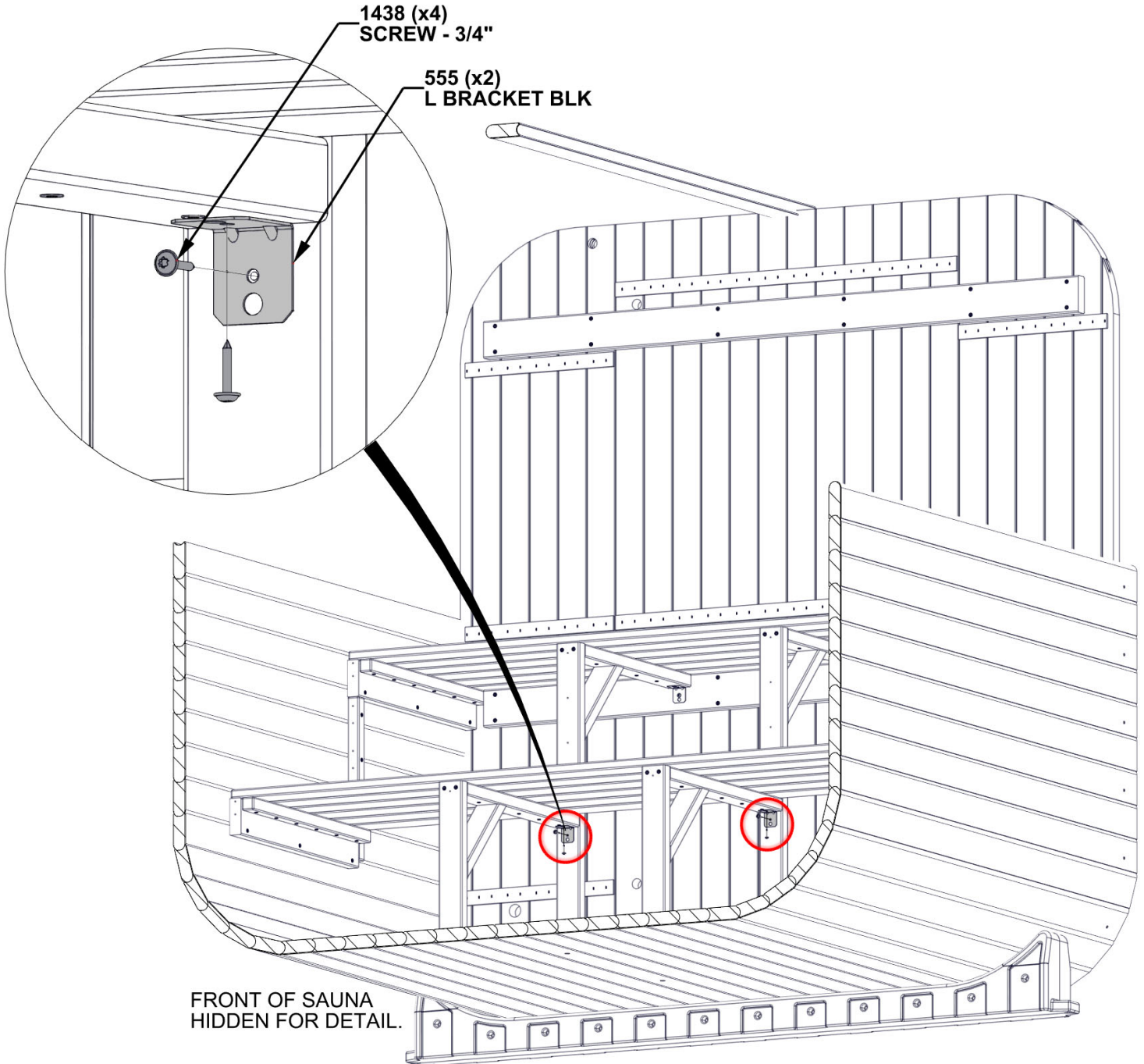

STEP 22 - BENCH ASSEMBLY

QTY	PART NUMBER	DESCRIPTION
2	H101429	SCREW TFH 8X2 SS-BLK

- INSERT SCREWS INTO THROUGH HOLES IN PREVIOUSLY INSTALLED FLOOR CLEAT AS SHOWN.

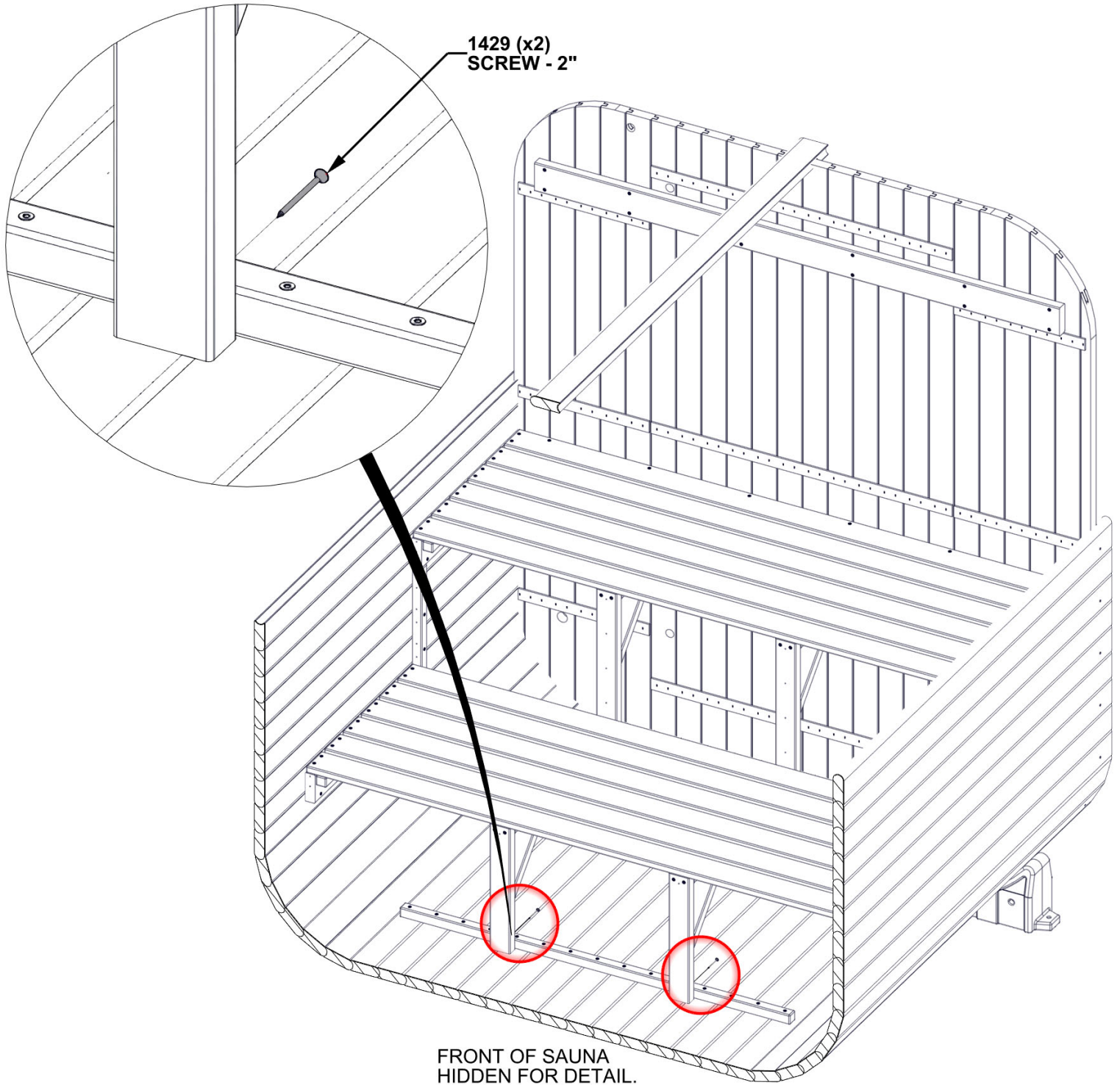

STEP 23 - BENCH ASSEMBLY

QTY	PART NUMBER	DESCRIPTION
12	H101430	SCREW TFH 8X2 1/4 SS-BLK



W01 SEAT TRIM - W4L21948
(x2) 1 9/16"x3 3/8"x65 3/4" (40x86x1670)

- ALIGN THROUGH HOLES IN SEAT TRIM WITH PILOT HOLES IN UPRIGHTS AND CLEATS AND ATTACH.

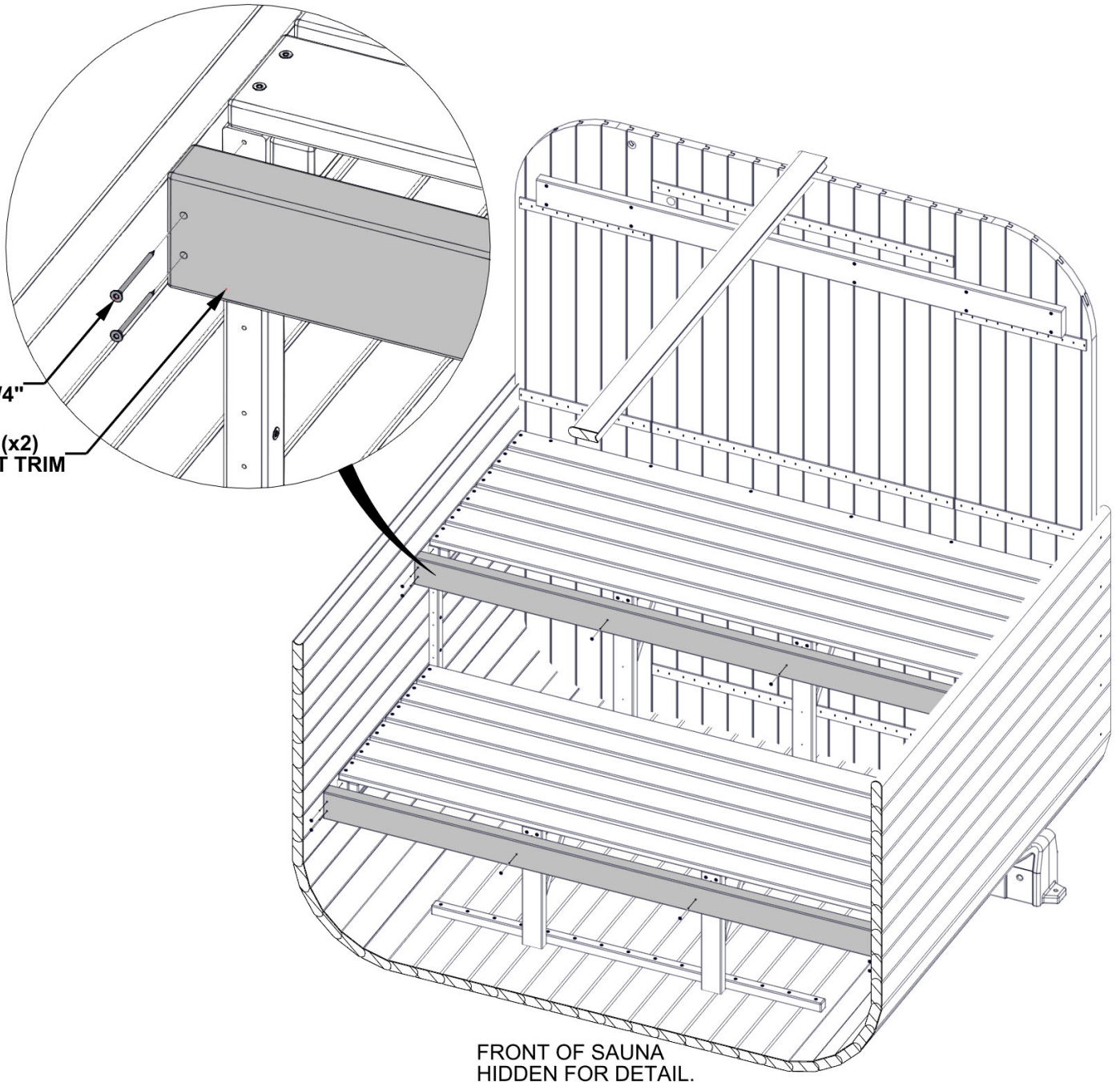

FRONT OF SAUNA
HIDDEN FOR DETAIL.

STEP 24 - SAUNA ASSEMBLY

QTY	PART NUMBER	DESCRIPTION
8	H101427	SCREW TFH 8X1 1/2 SS-BLK

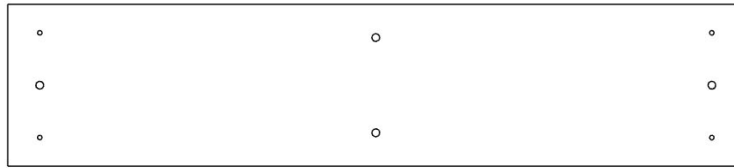

Y01 HEATER SPACER BOARD - W4L22601
(x2) 5/8"x4"x18 1/4" (16x102x464)

- BUTT TOP OF Y01 AGAINST BOTTOM OF CLEAT AS SHOWN AND ATTACH.
- USING MEASUREMENT GIVEN. ATTACH OTHER BOARD.
- **DO NOT INSERT SCREWS INTO THE SMALLER PILOT HOLES.**

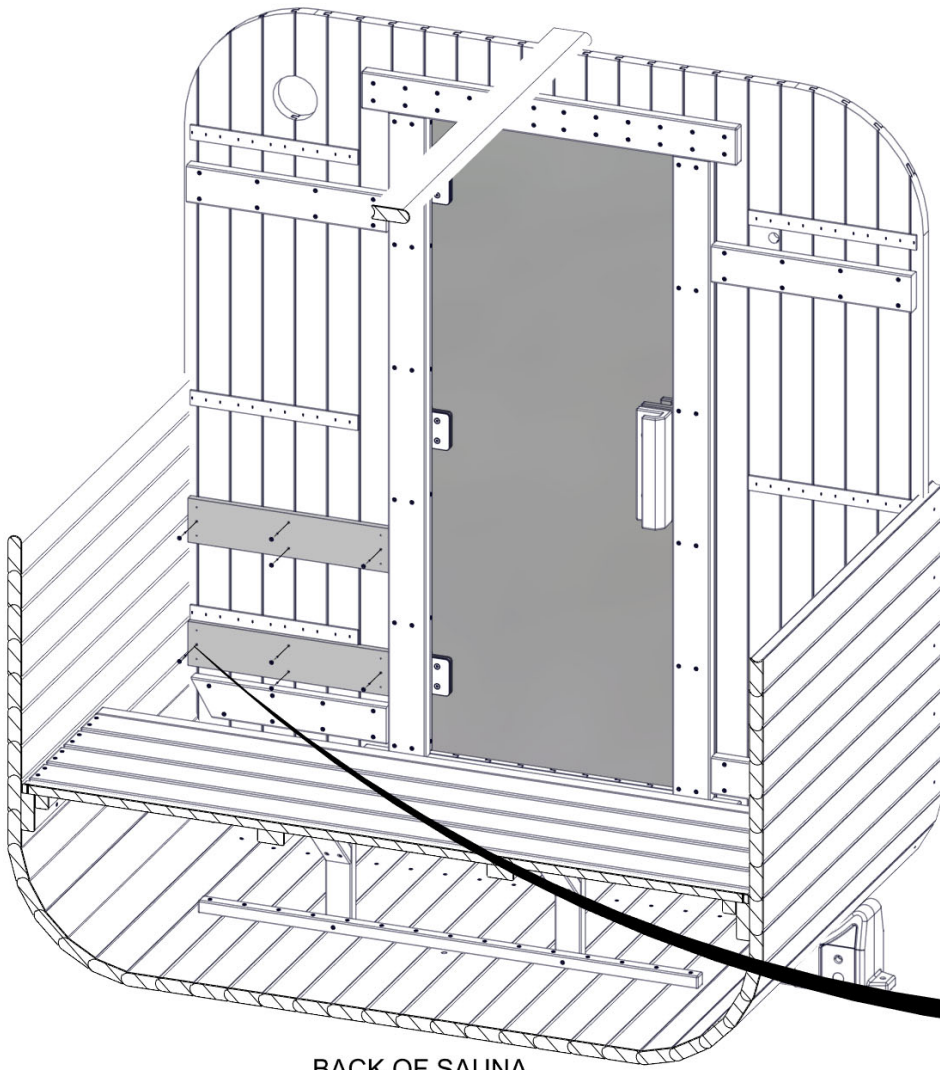

BACK OF SAUNA
HIDDEN FOR DETAIL.

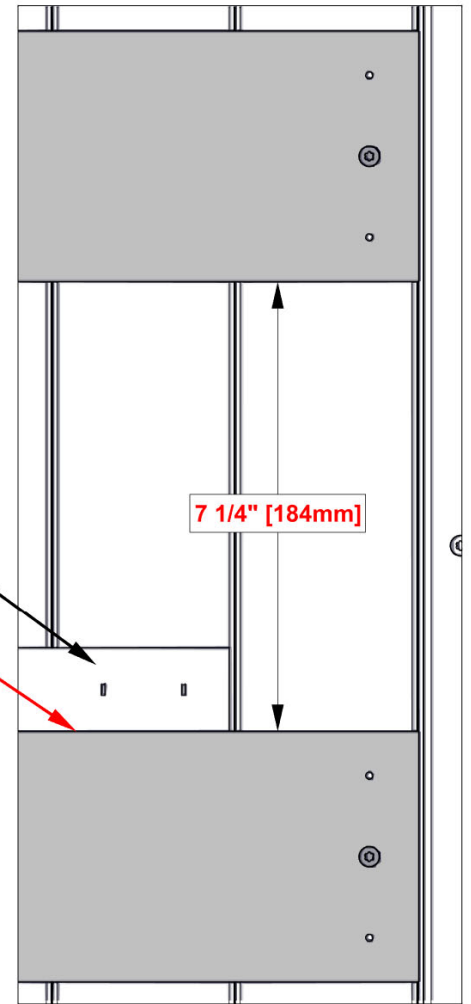

CLEAT

FLUSH

7 1/4" [184mm]

1427 (8x)
SCREW - 1 1/2"

Y01 (x2)
HEATER SPACER BOARD

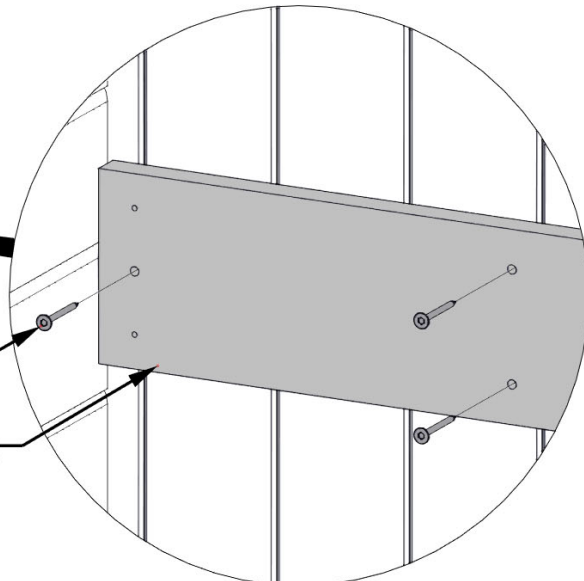

STEP 25 - HEATER MOUNT INSTALLATION

QTY	PART NUMBER	DESCRIPTION
8	H101468	SCREW RAISED HEAD 8x1"

- INSERT SCREWS INTO PILOT HOLES IN BOARDS INSTALLED IN PREVIOUS STEP.

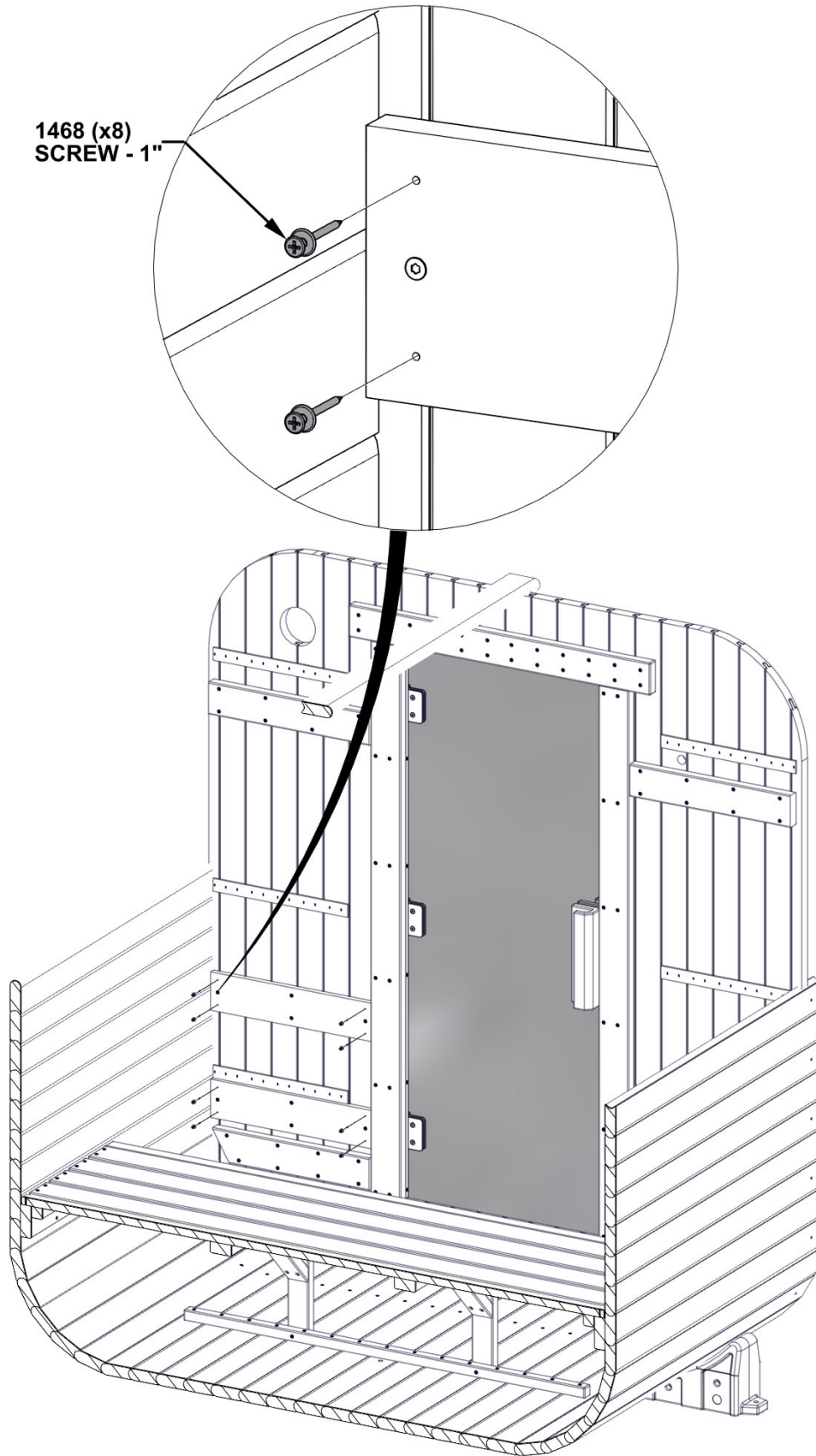

STEP 26 - HEATER GUARD ASSEMBLY

QTY	PART NUMBER	DESCRIPTION
25	H101428	SCREW TFH 8X1 3/4 SS-BLK



NR04 HEATER GUARD BOARD - W4L22037
(x5) 13/16"x2 3/8"x15 11/16" (20x60x398)



NR03 HEATER GUARD BOARD - W4L22036
(x5) 13/16"x2 3/8"x20 3/8" (20x60x518)



OO04 HEATER GUARD BOARD - W4L22035
(x1) 1 3/16"x1 3/16"x16 1/8" (30x30x410)

- ALIGN THROUGH HOLES WITH PILOT HOLES AND ATTACH AS SHOWN.

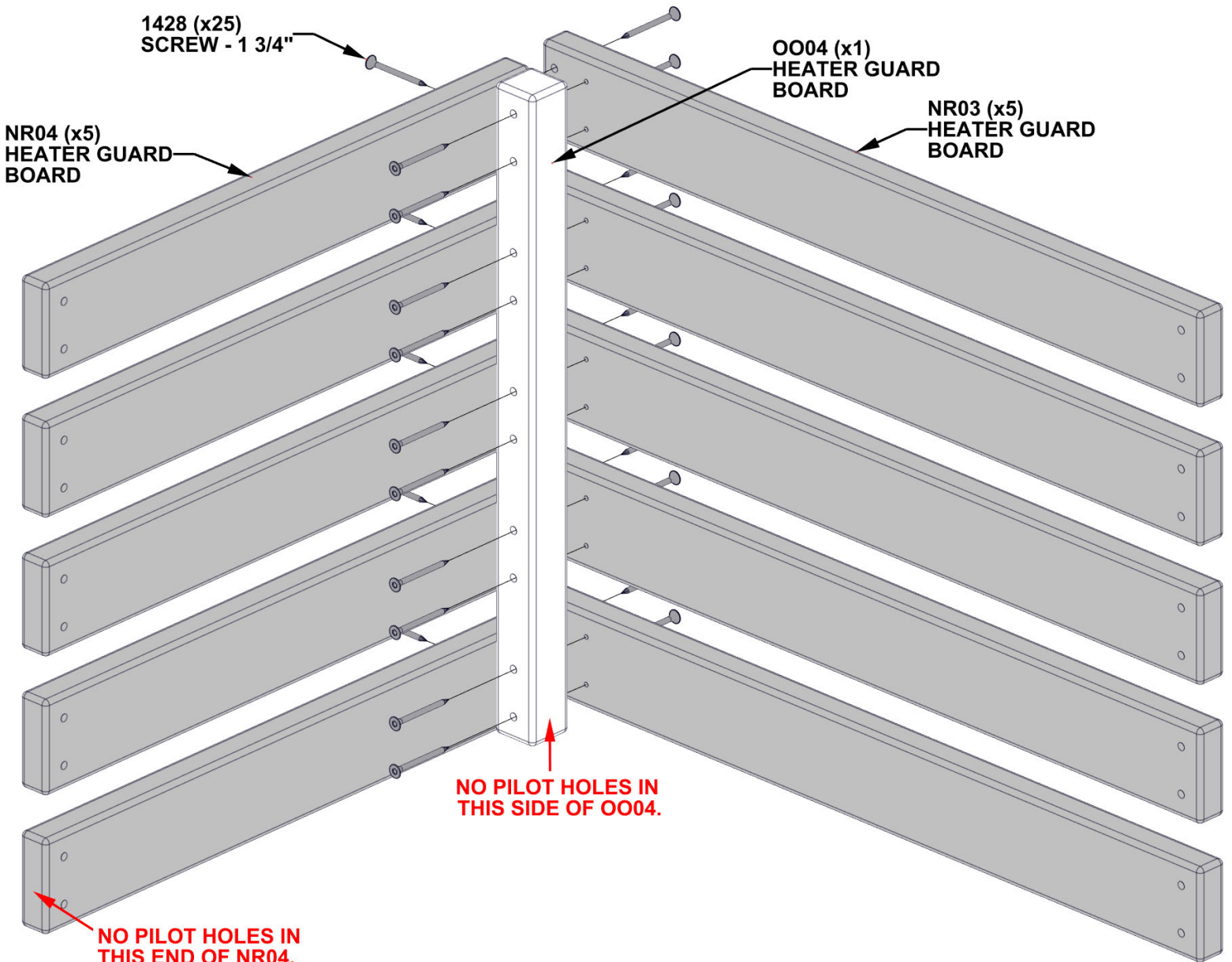

STEP 27 - HEATER GUARD ASSEMBLY

QTY	PART NUMBER	DESCRIPTION
20	H101428	SCREW TFH 8X1 3/4 SS-BLK

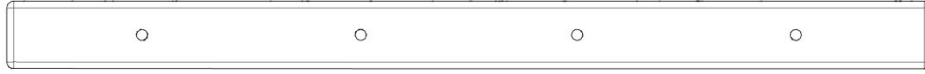

OO03 HEATER GUARD BOARD - W4L22038
(x2) 1 3/16"x1 3/16"x16 1/8" (30x30x410)

- ALIGN THROUGH HOLES WITH PILOT HOLES AND ATTACH AS SHOWN.

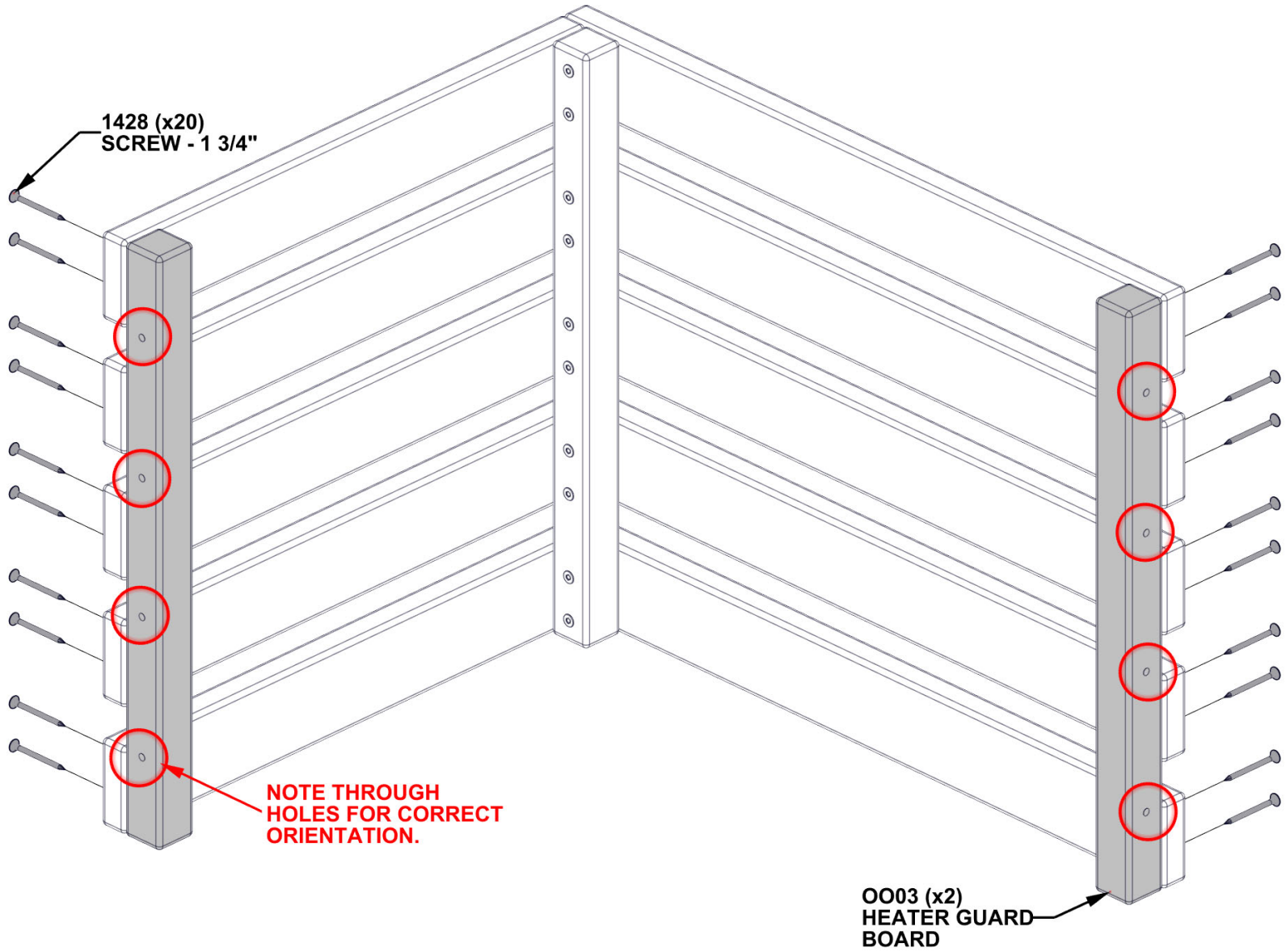

STEP 28 - HEATER GUARD ASSEMBLY

QTY	PART NUMBER	DESCRIPTION
8	H101429	SCREW TFH 8X2 SS-BLK

- MEASURE FROM THE SAUNA FLOOR TO THE BOTTOM OF THE HEATER GUARD ASSEMBLY FOR CORRECT PLACEMENT.
- ENSURE HEATER GUARD CLEAT IS FLUSH WITH OUTSIDE OF DOOR FRAME AS SHOWN.
- ONCE THE HEATER GUARD ASSEMBLY IS CORRECTLY LOCATED, ATTACH WITH SCREWS.

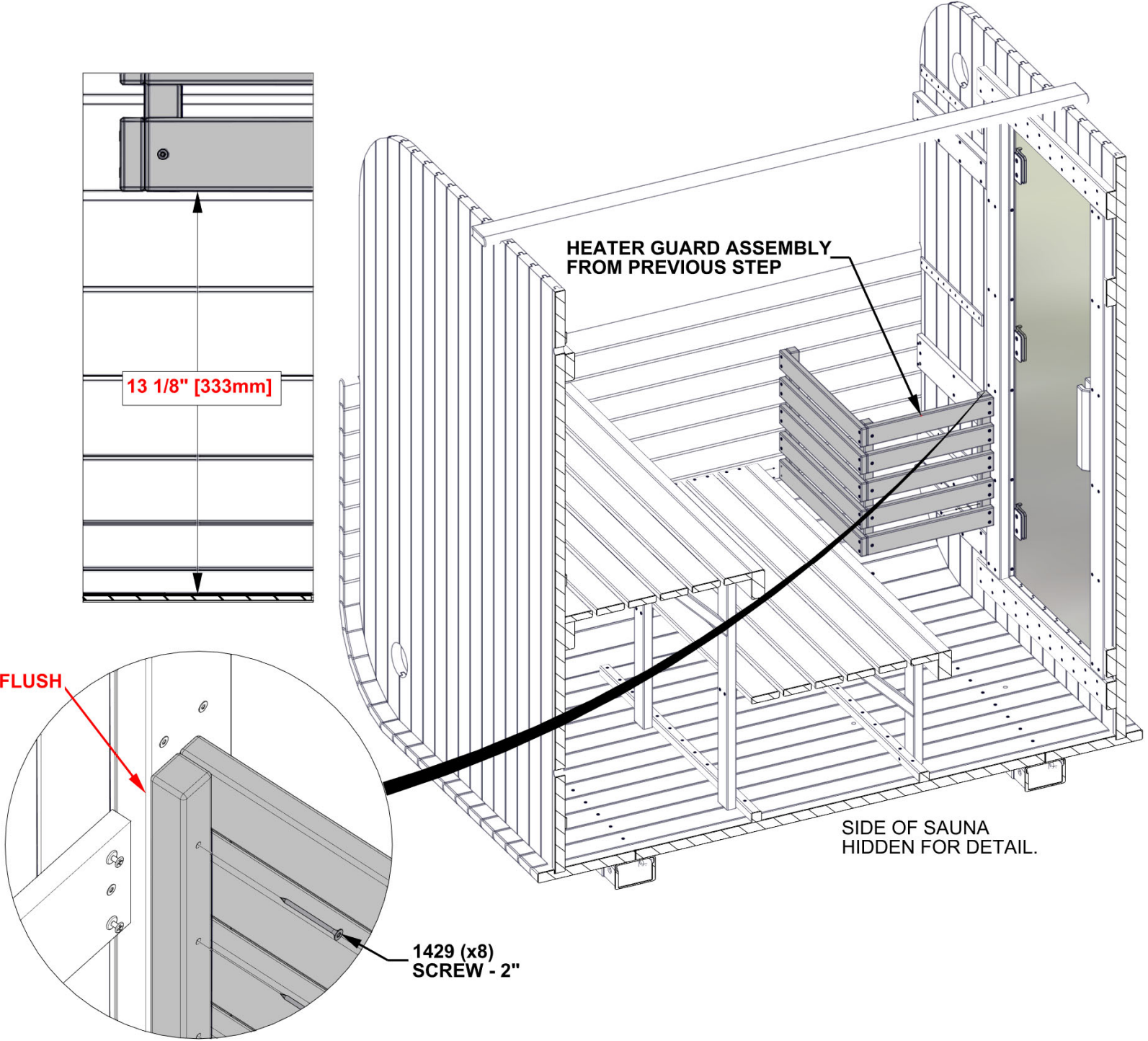

STEP 29 - SAUNA ASSEMBLY

QTY	PART NUMBER	DESCRIPTION
16	H101413	NAIL STD 2.5x50 GLV



OG01 PERIMETER BOARD - W4L21936
(x16) 1 3/16"x3 3/8"x74 5/8" (30x86x1895)

- ALIGN GROOVE IN PERIMETER BOARDS WITH BOTH FRONT WALL AND BACK WALL ASSEMBLIES.
- WORKING UPWARDS, STACK 8 BOARDS ON EACH SIDE OF THE PERIMETER BOARD/BASE AS SHOWN.
- FASTEN APPROXIMATELY EVERY OTHER PERIMETER BOARD TO THE WALLS WITH H101413 TO HOLD IN PLACE.
- IF YOU HAVE ACCESS TO A PNEUMATIC NAILER, THIS STEP WILL GO FASTER.

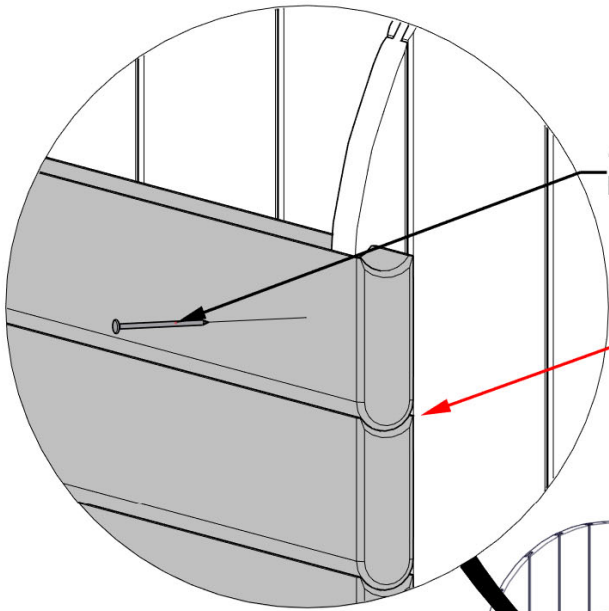

1413 (x16)
NAIL - 2"

ENSURE EACH PERIMETER BOARD FITS FIRMLY TOGETHER WITH THE PREVIOUS BOARD AS SHOWN.

OG01 (x16)
PERIMETER BOARD

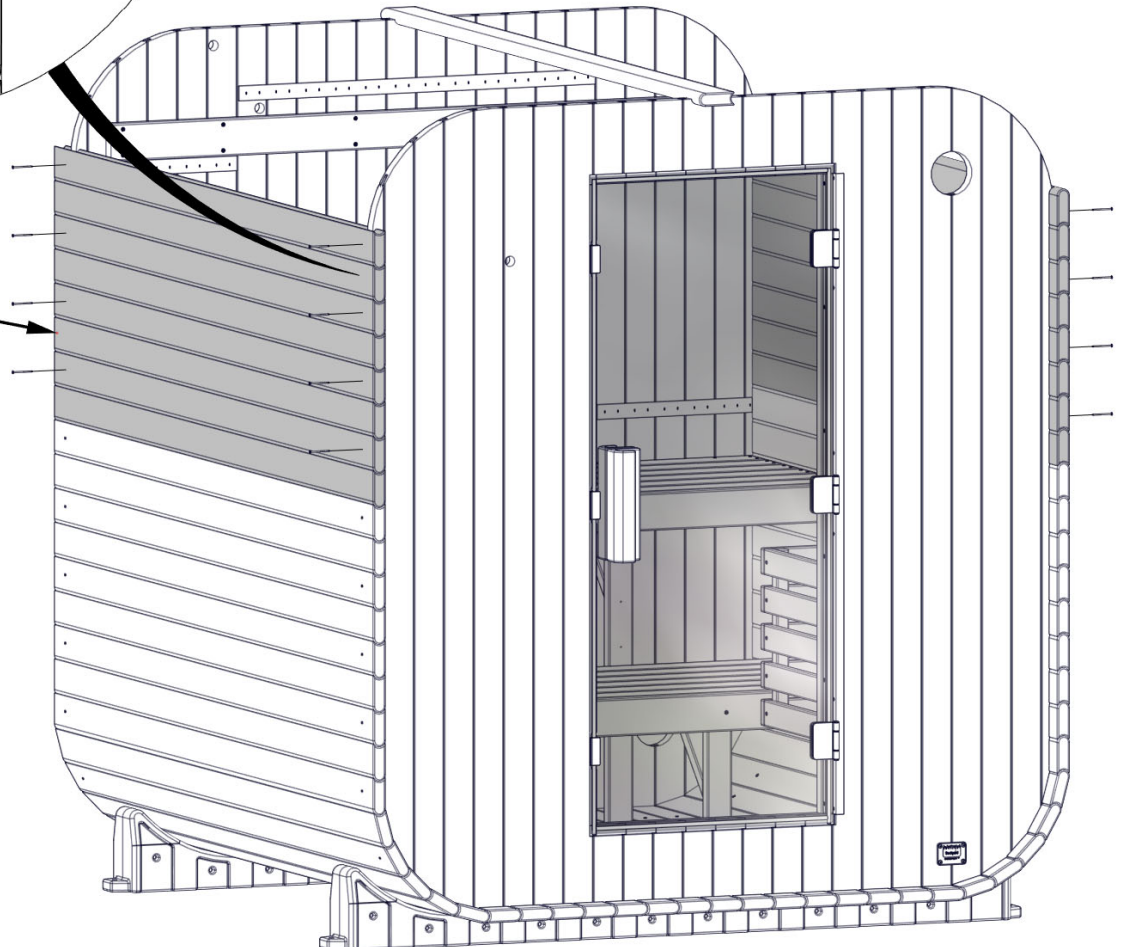

STEP 30 - SAUNA ASSEMBLY

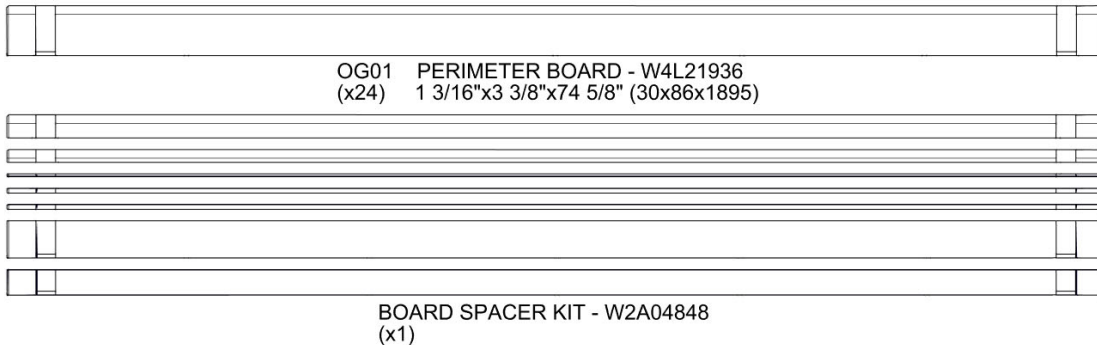

- A ROPE OR STRAP IS SUGGESTED TO BE LOOSELY TIED/ATTACHED AROUND THE SAUNA TO HELP HOLD BOARDS IN PLACE.
- ALIGN GROOVE IN PERIMETER BOARDS WITH BOTH FRONT WALL AND BACK WALL ASSEMBLIES.
- WORKING UPWARDS, STACK PERIMETER BOARDS TO BOTH SIDES UNTIL THEY MEET AT THE TOP
- REMOVE TOP BOARD THAT WAS INSTALLED EARLIER TO HOLD THE WALLS AND REATTACH WHERE IT FITS BEST TO COMPLETE THE SAUNA PERIMETER.
- FASTEN ONE OR TWO OF THE PERIMETER BOARDS TO THE WALLS WITH A SMALL NAIL TO HOLD IN PLACE.
- IT IS POSSIBLE SOME SPACER BOARDS, FROM THE BOARD SPACER KIT, WILL BE NEEDED TO FILL ANY GAPS BETWEEN THE PERIMETER BOARDS FOR A SNUG FIT.

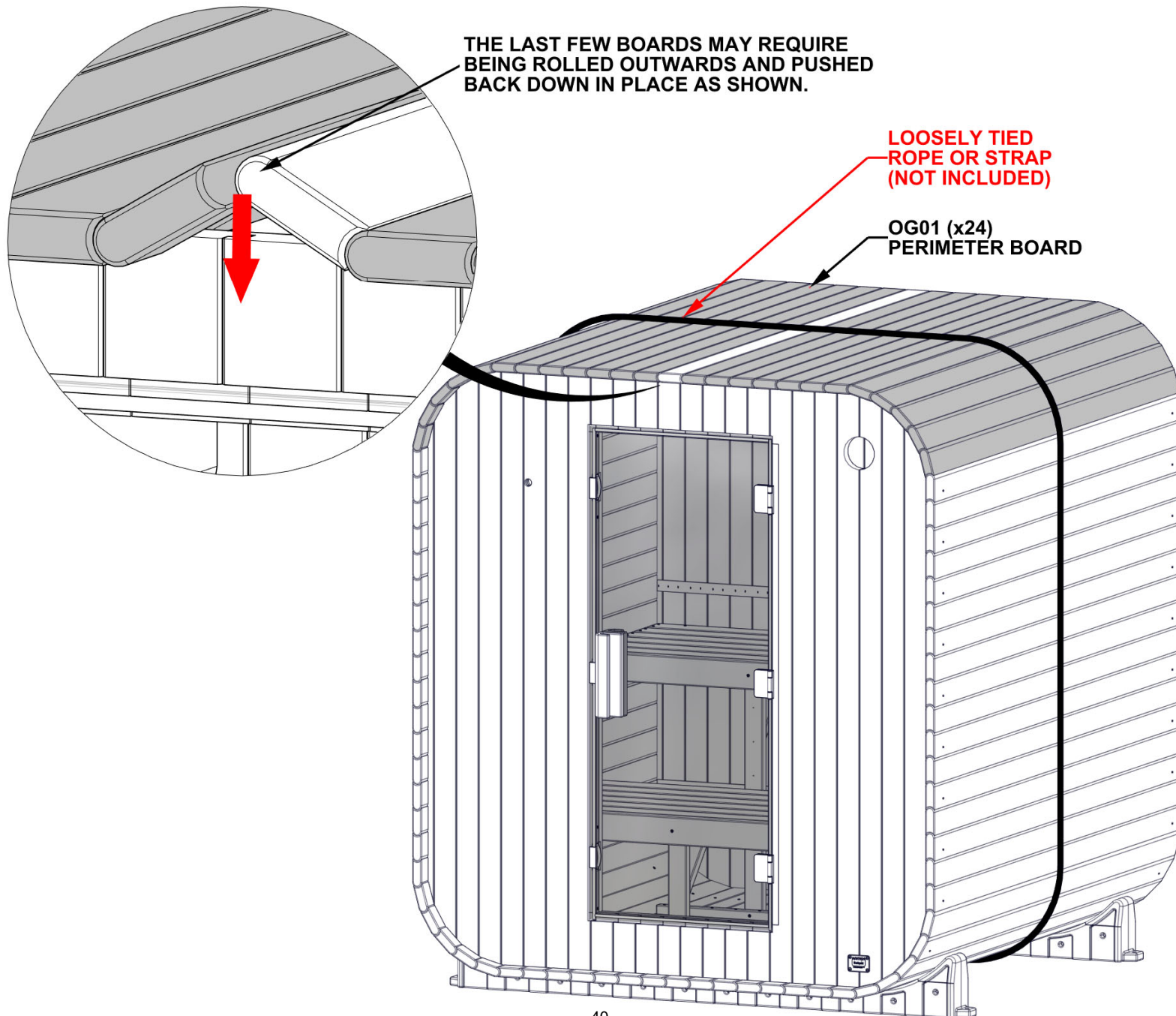

STEP 31 - STRAPPING ASSEMBLY

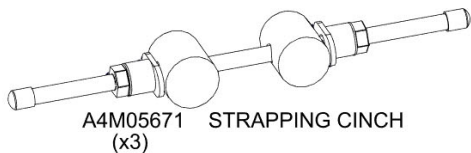

- WRAP STRAPPING AROUND SAUNA AS SHOWN.
- POSITION TWO STRAPS TO COVER THE NAILS INSTALLED IN STEP 9.
- POSITION THE THIRD STRAP CENTERED BETWEEN THE OTHER TWO STRAPS.
- INSERT STRAPPING CINCH INSERTS INTO THE EYES ON STRAPPING.
- INSERT THE ALL THREAD THROUGH THE INSERTS AND CONNECT HARDWARE AS SHOWN.
- BEFORE TIGHTENING, VERIFY STRAPPING IS PROPERLY POSITIONED AND STRAIGHT.
- THE STRAPPING CINCHES CAN BE EITHER ALIGNED OR STAGGERED BASED ON PERSONAL PREFERENCE.
- TIGHTEN ALL NUTS EVENLY.
- REMOVE ROPE/STRAP IF USED FROM PREVIOUS STEP.

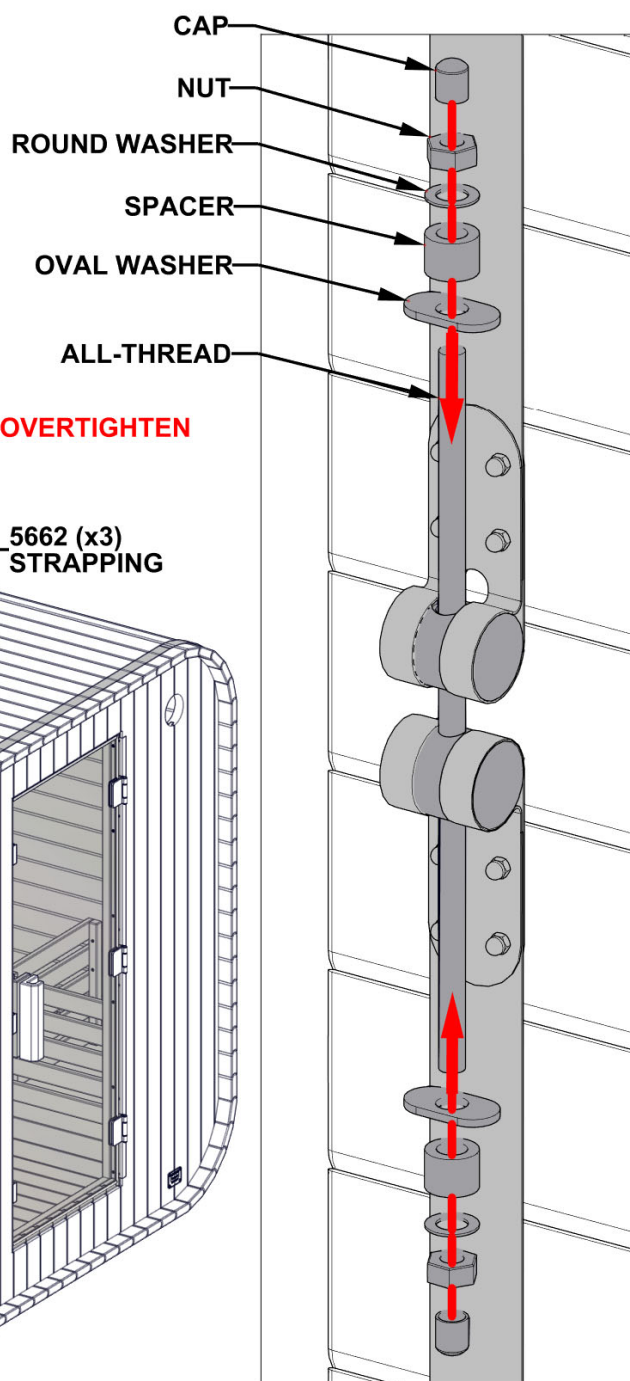
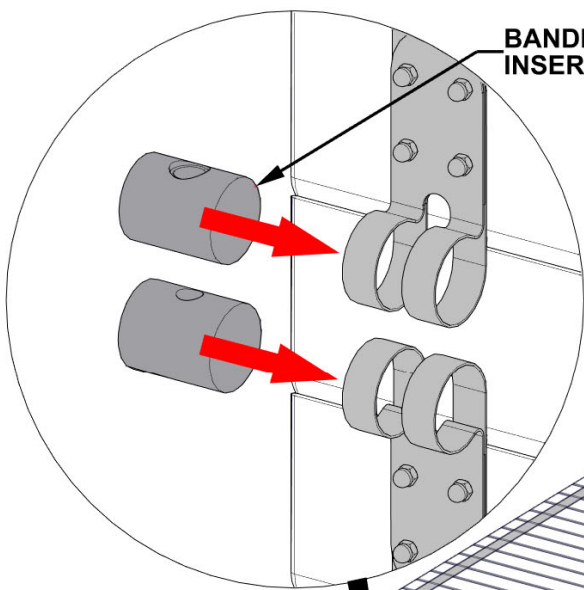

IMPORTANT: DO NOT OVERTIGHTEN

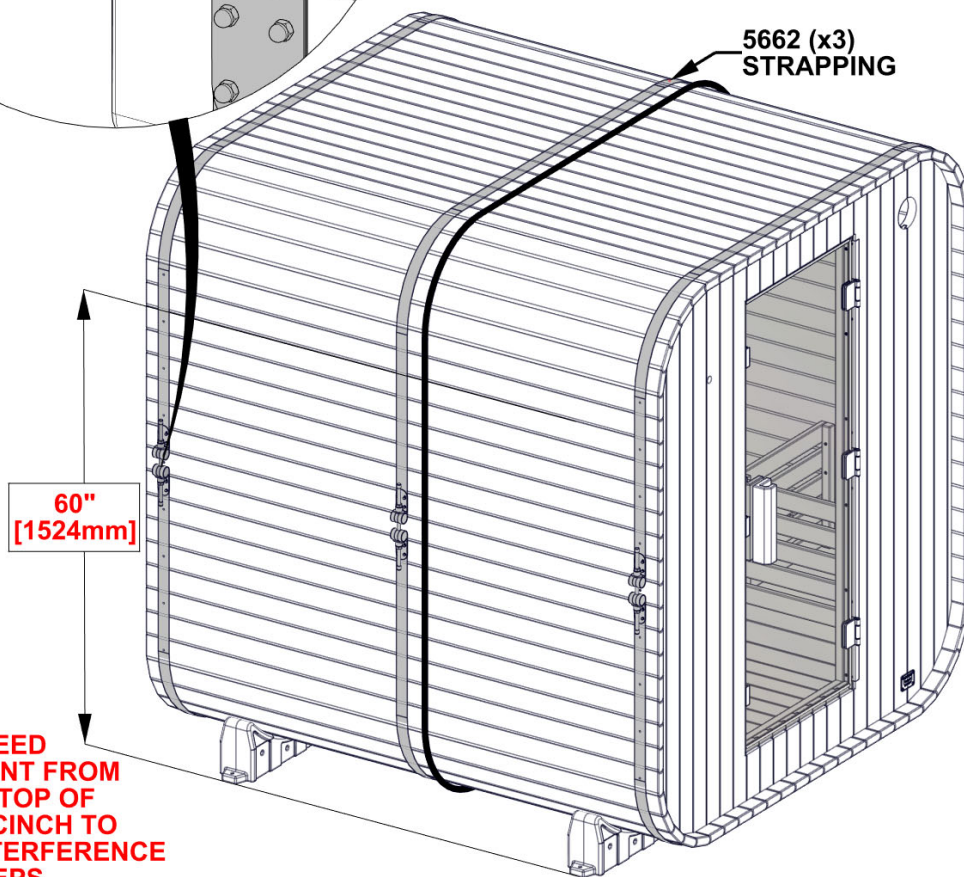

DO NOT EXCEED MEASUREMENT FROM GROUND TO TOP OF STRAPPING CINCH TO PREVENT INTERFERENCE IN LATER STEPS.

STEP 32 - VENT ASSEMBLY

QTY	PART NUMBER	DESCRIPTION
3	H101426	SCREW TFH 8X1 1/4 SS-BLK
4	H101438	SCREW TWH 8x3/4 SS-BLK

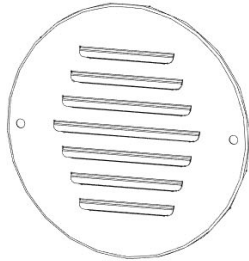

A4M05285 VENT
(x2)

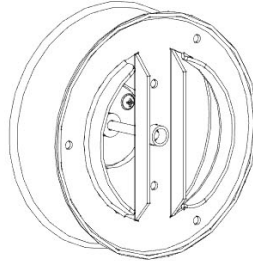

A4M05592 VENT COVER
(x1)

- BEFORE ATTACHING VENT COVER, UNSCREW ADJUSTABLE VENT COVER FROM VENT BASE INSERT.
- ONCE VENT BASE INSERT IS ATTACHED, SCREW ADJUSTABLE VENT COVER BACK IN.

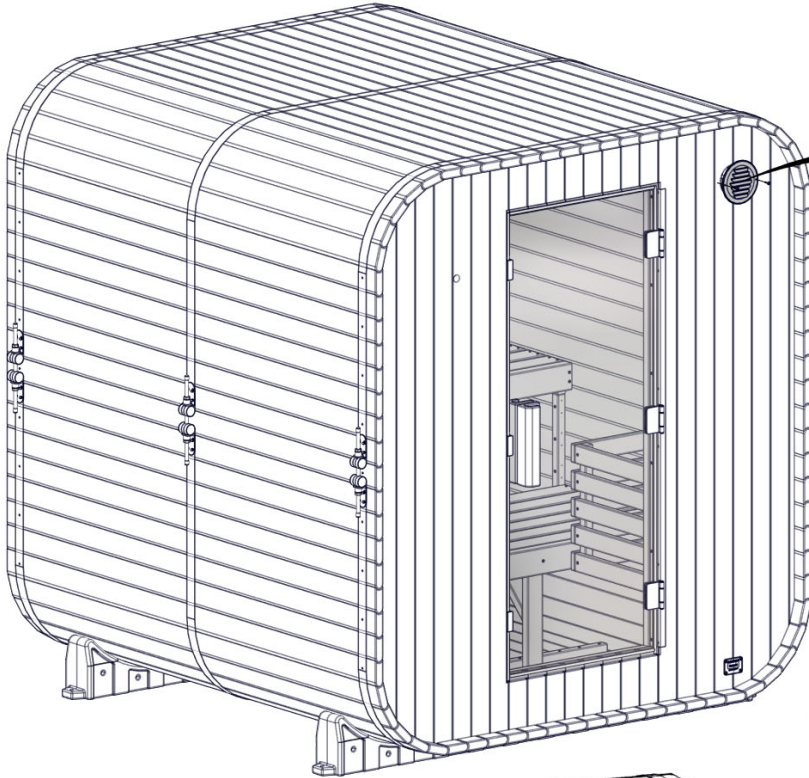

5285 (x2)
VENT

VENT BASE
INSERT

1426 (x3)
SCREW - 1 1/4"

ADJUSTABLE
VENT COVER

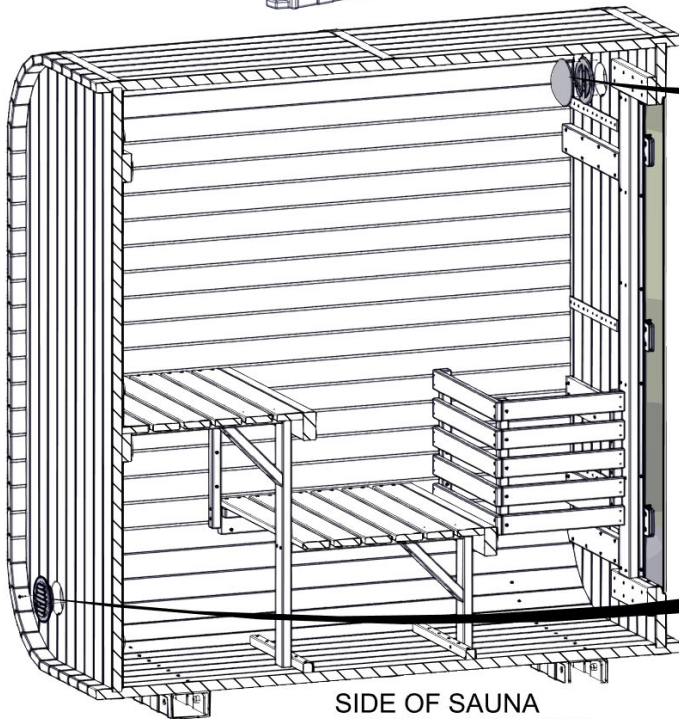
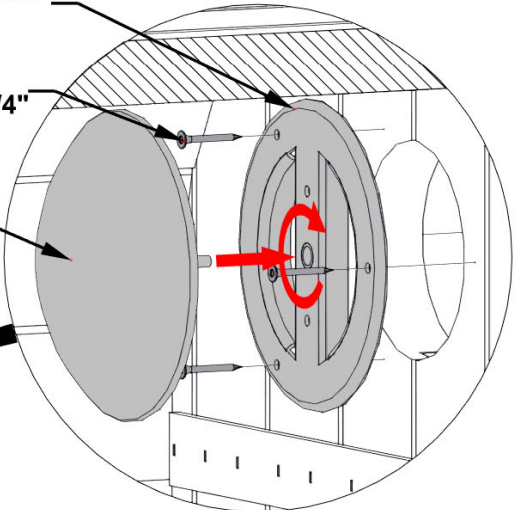
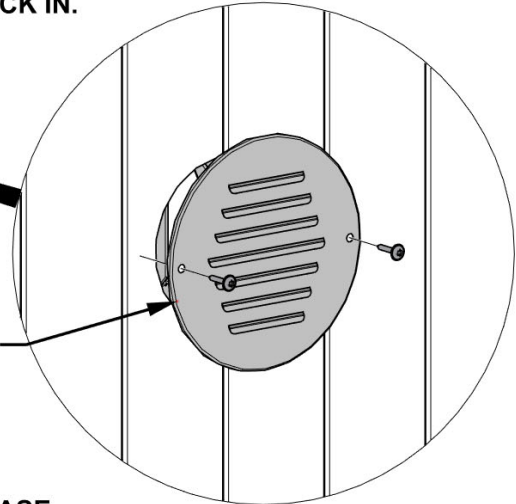

SIDE OF SAUNA
HIDDEN FOR DETAIL.

1438 (x4)
SCREW - 3/4"

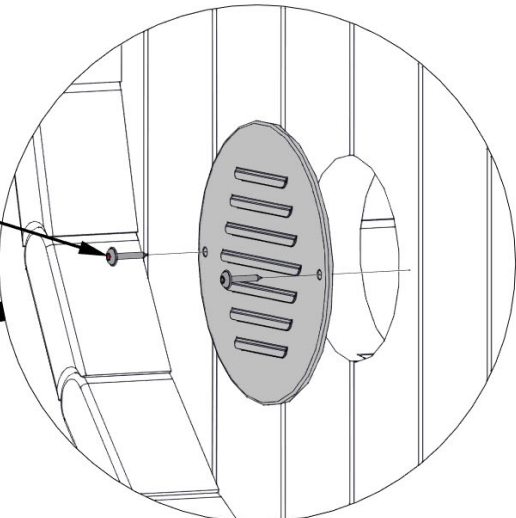

STEP 33 - TRIM ASSEMBLY

QTY	PART NUMBER	DESCRIPTION
44	H101429	SCREW TFH 8X2 SS-BLK



NR01 TRIM - W4L22033
(x2) 13/16"x2 3/8"x44 1/2" (20x60x1130)

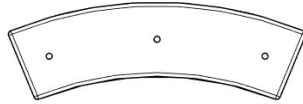

NG02 TRIM - W4L22032
(x8) 13/16"x3 1/8"x9 9/16" (20x80x243)



NR02 TRIM - W4L22034
(x4) 13/16"x2 3/8"x4 1/4" (20x60x108)

- CENTER NR01 BOARD ON SAUNA FRONT.
- ENSURE NOTCH IS FLUSH WITH TOP OF SAUNA AS SHOWN AND ATTACH.
- ALIGN NG02 AND NR02 BOARDS WITH NR01 AND ATTACH.
- COMPLETE ON FRONT AND BACK OF SAUNA.

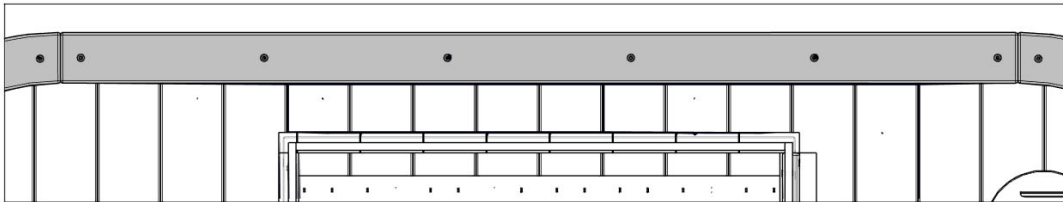

FRONT VIEW

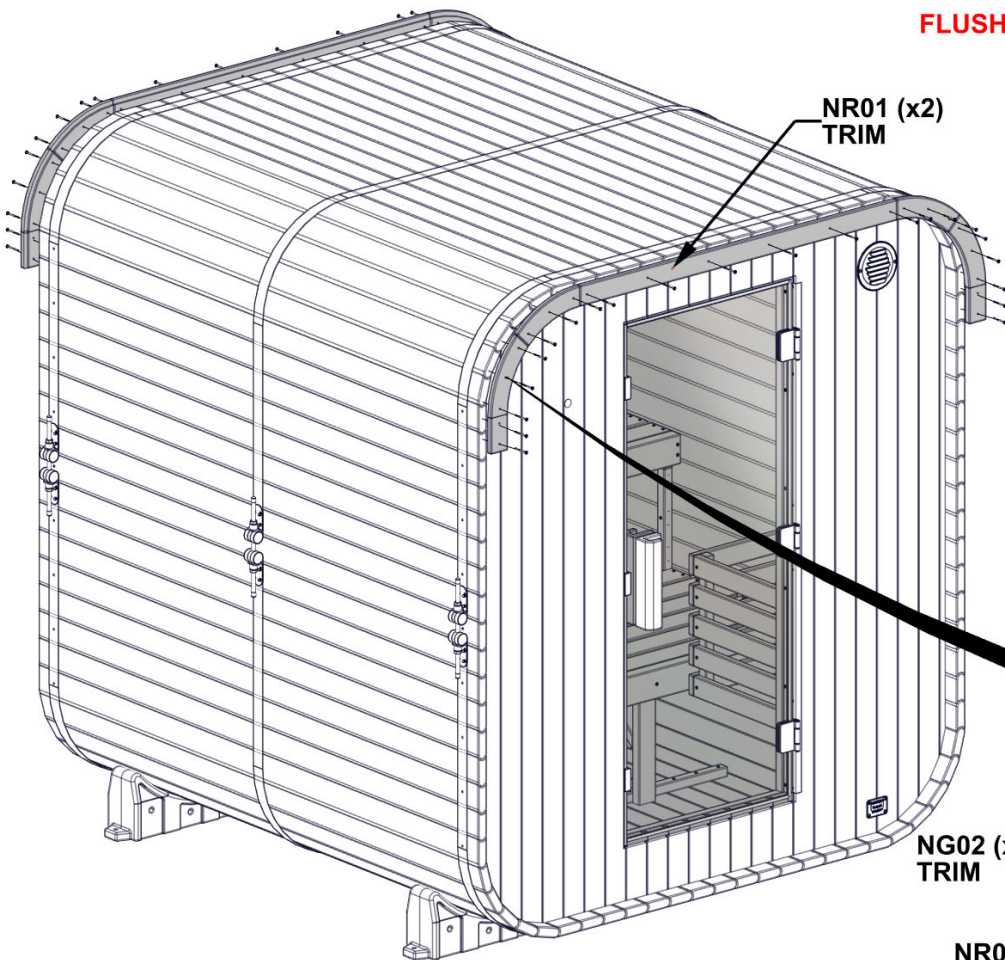

FLUSH

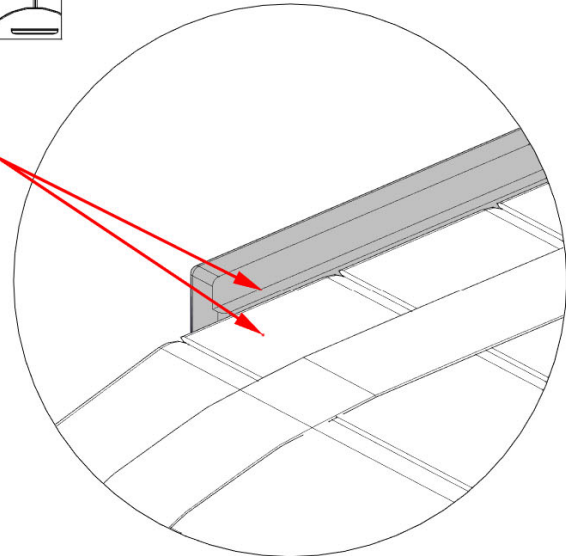

NG02 (x8)
TRIM

NR02 (x2)
TRIM

1429 (x44)
SCREW - 2"

STEP 34 - ROOF ASSEMBLY

QTY	PART NUMBER	DESCRIPTION
40	H101117	SCREW WOODGRIP 10-16x3/4" BLK

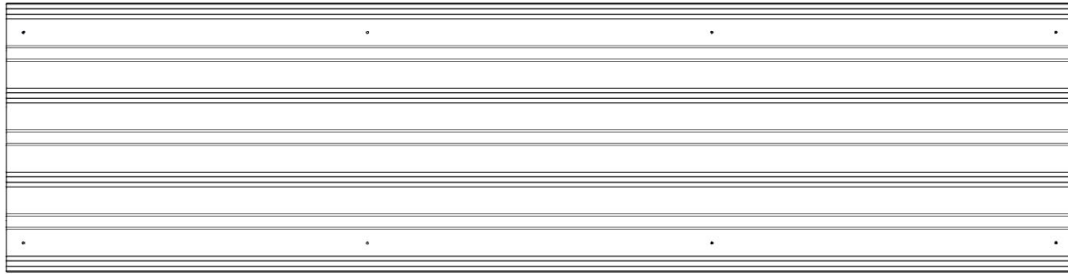

A4M05663 29 GA SHEETING
(x5)

- **WARNING: USE GLOVES WHEN HANDLING STEEL SHEETING.**
- **IMPORTANT: REMOVE BLUE FILM BEFORE INSTALLATION.**
- **INSTALL SHEETS STARTING WITH THE TOP MIDDLE SHEET AS SHOWN.**
- **ENSURE THAT THE SHEET IS CENTERED ON TOP OF THE SAUNA.**
- **CONTINUE INSTALLING SHEETS ON THE RIGHT SIDE OF SAUNA ENSURING CORRECT OVERLAP.**
- **AFTER THE FIRST 3 SHEETS HAVE BEEN INSTALLED, INSTALL THE 2 REMAINING LEFT SHEETS.**
- **IMPORTANT: EACH UPPER SHEET MUST OVERLAP THE LOWER SHEET. THIS IS CRITICAL TO AVOID LEAKING.**

CENTER MIDDLE RIB AS SHOWN.

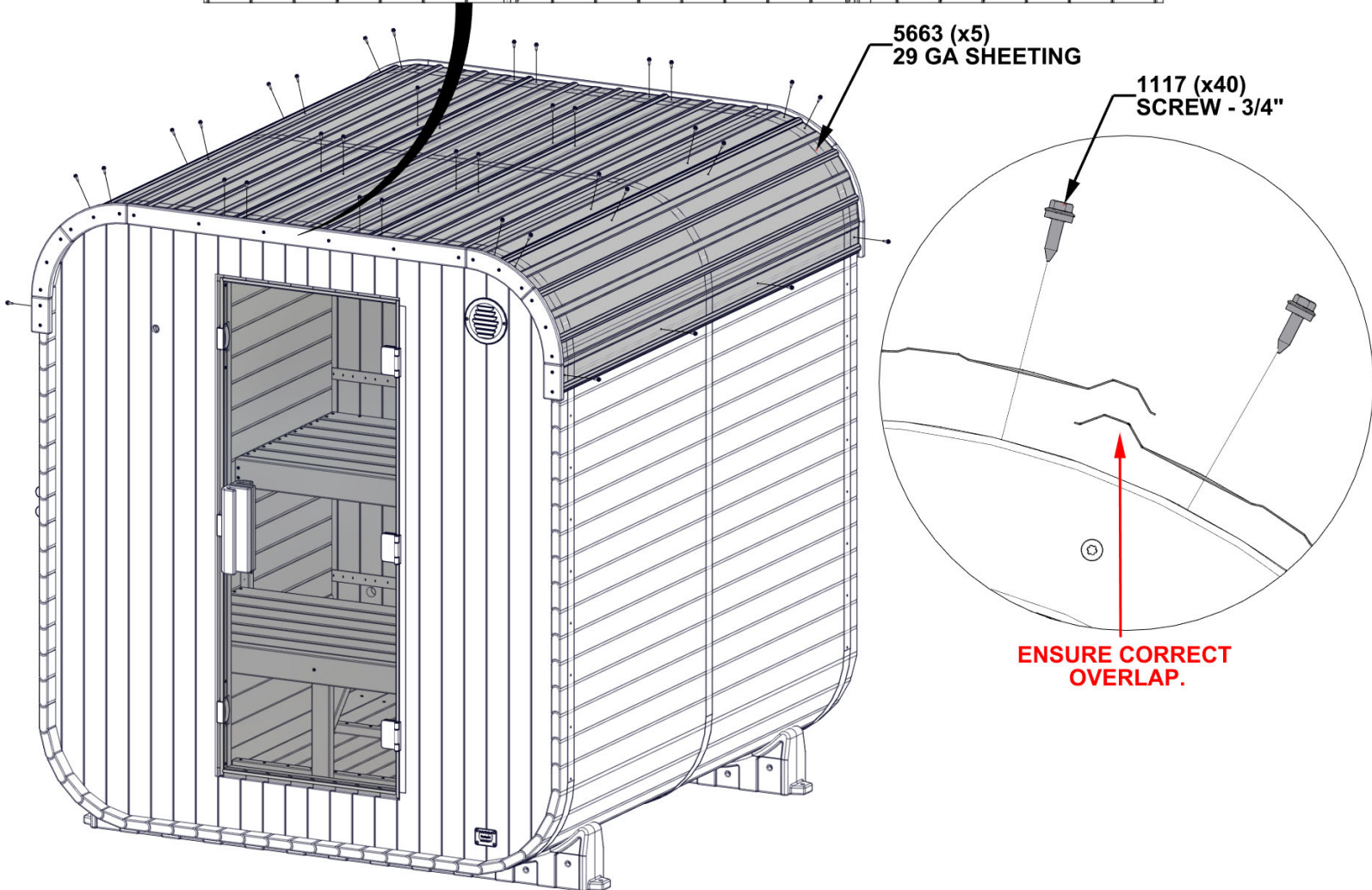
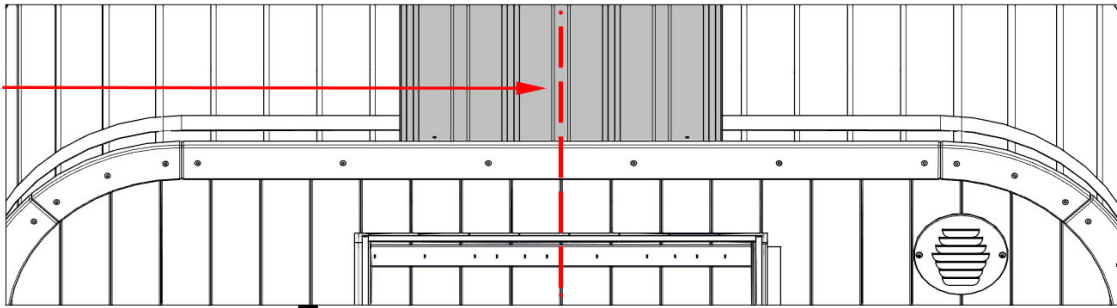

ENSURE CORRECT OVERLAP.

STEP 35 - LIGHT ASSEMBLY

QTY	PART NUMBER	DESCRIPTION
4	H101437	SCREW TWH 8x5/8 SS-BLK

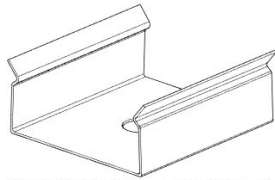

A6P01493-04 LIGHT CLIP
(x4)

- ATTACH LIGHT CLIPS IN APPROXIMATE LOCATIONS SHOWN.
- USE DIMENSIONS GIVEN BETWEEN LIGHT CLIPS AND CENTER ON BOARDS.

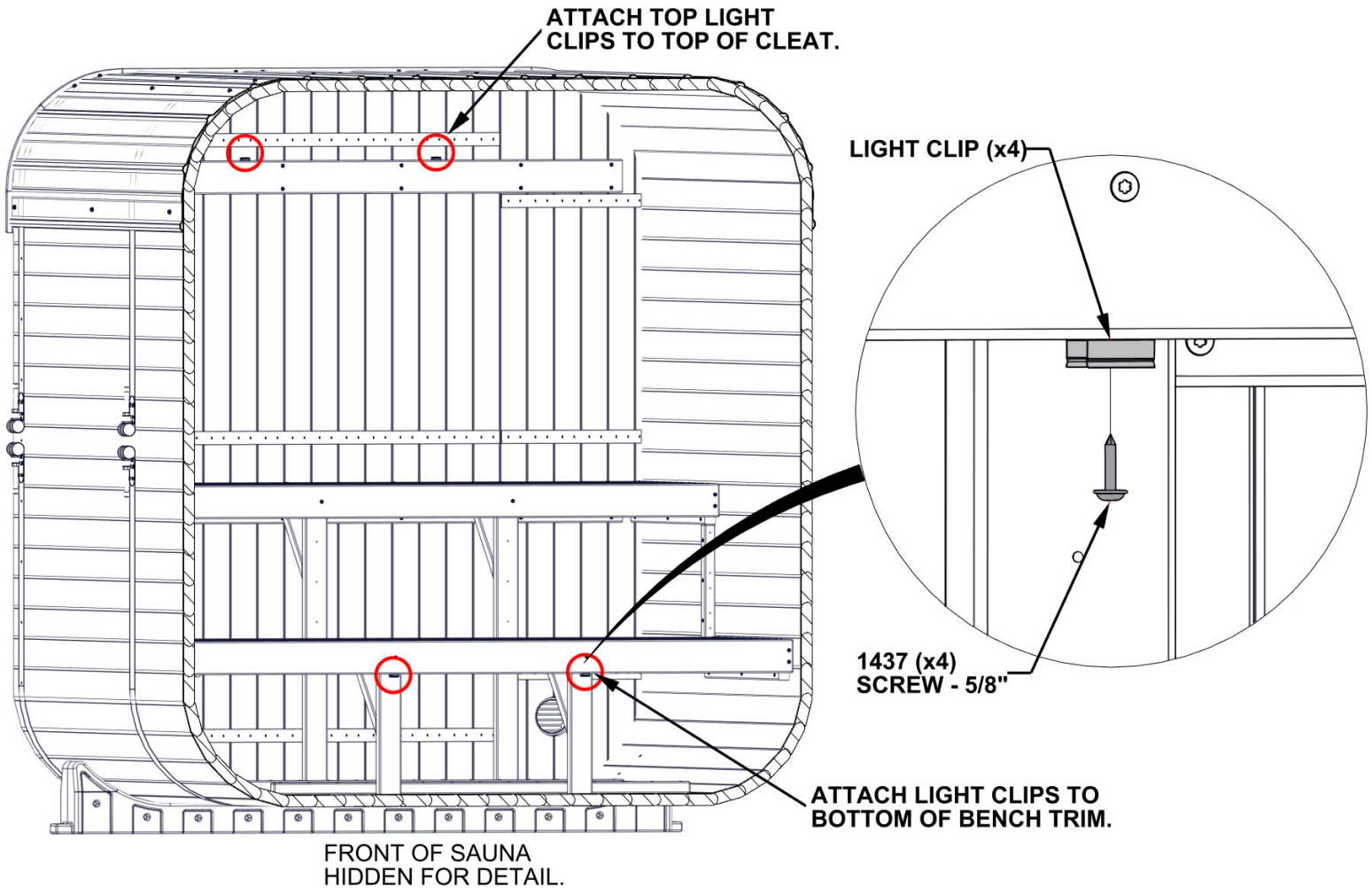
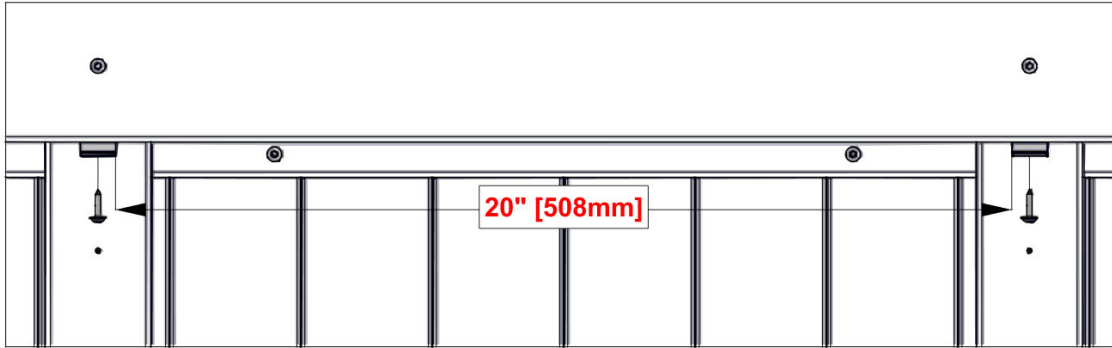

STEP 36 - LIGHT ASSEMBLY

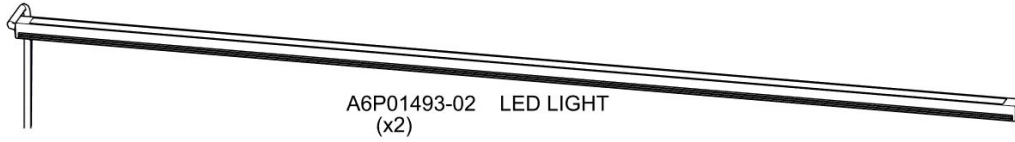

- BEFORE CLIPPING LIGHTS INTO PLACE, RUN CORDS THROUGH CORRESPONDING THROUGH HOLES IN BACK WALL.
- SNAP LED LIGHTS INTO LIGHT CLIPS.

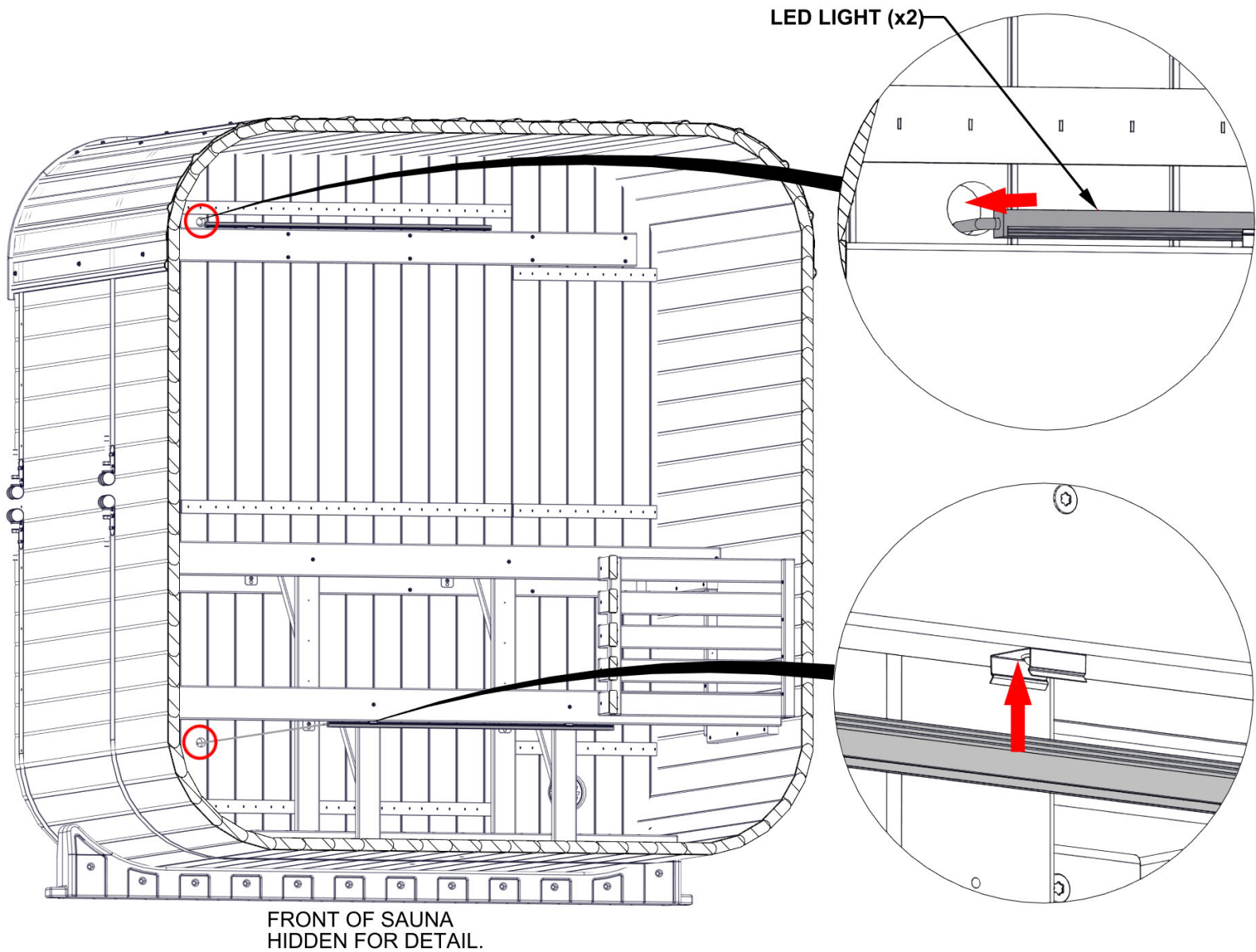

STEP 37 - BENCH ASSEMBLY

QTY	PART NUMBER	DESCRIPTION
18	H101428	SCREW TFH 8X1 3/4 SS-BLK



NG01 SLAT - W4L21949
(x3) 13/16"x3 3/8"x65 3/4" (20x86x1670)

- ALIGN THROUGH HOLES IN SLATS WITH PILOT HOLES IN CLEATS AND UPRIGHTS.

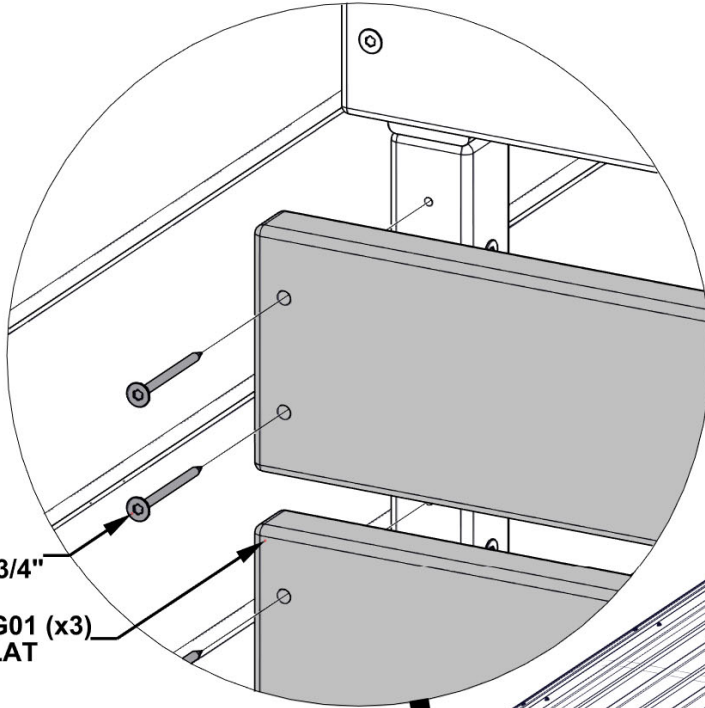

1428 (x18)
SCREW - 1 3/4"

NG01 (x3)
SLAT

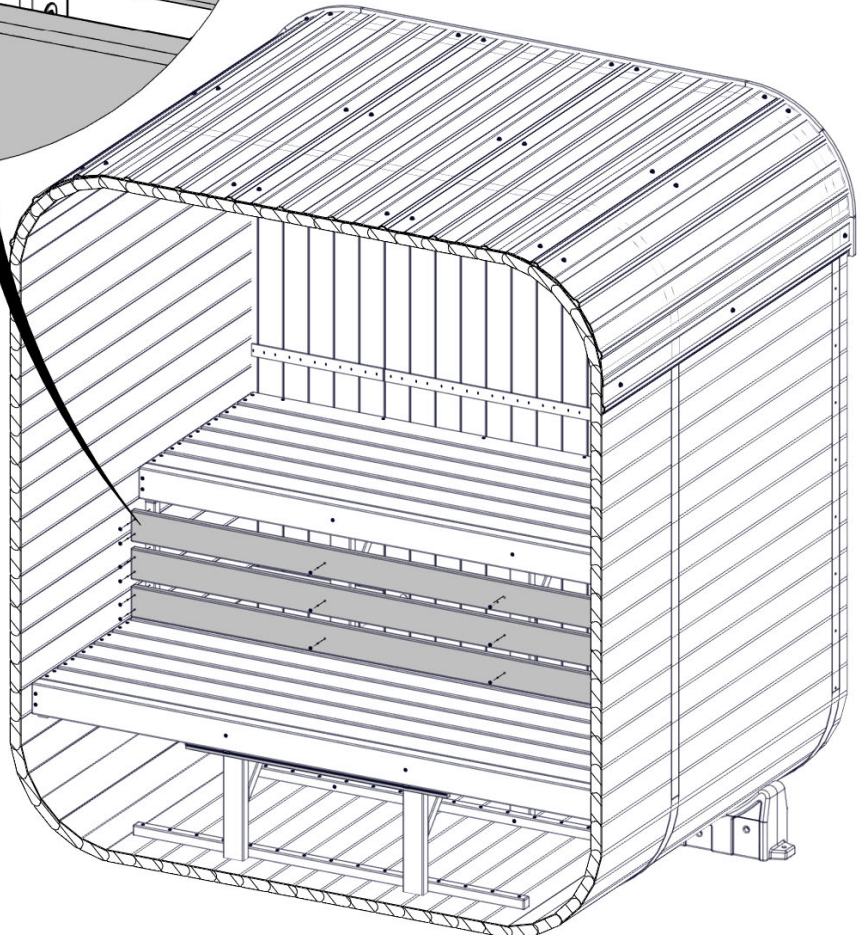

FRONT OF SAUNA
HIDDEN FOR DETAIL.

STEP 38 - CONTROL PANEL ASSEMBLY

QTY	PART NUMBER	DESCRIPTION
2	H100627	SCREW PFH 6x3/4 BLK

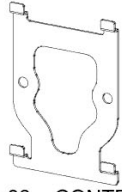

A4M05590-03 CONTROL PANEL MOUNTING BRACKET (x1)

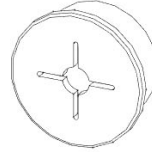

A6P01467 SILICONE GROMMET 25mm (x1)

- CENTER MOUNTING BRACKET SLIGHTLY OVER CUTOUT IN WALL PANEL AND ATTACH AS SHOWN.
- INSERT GROMMET.

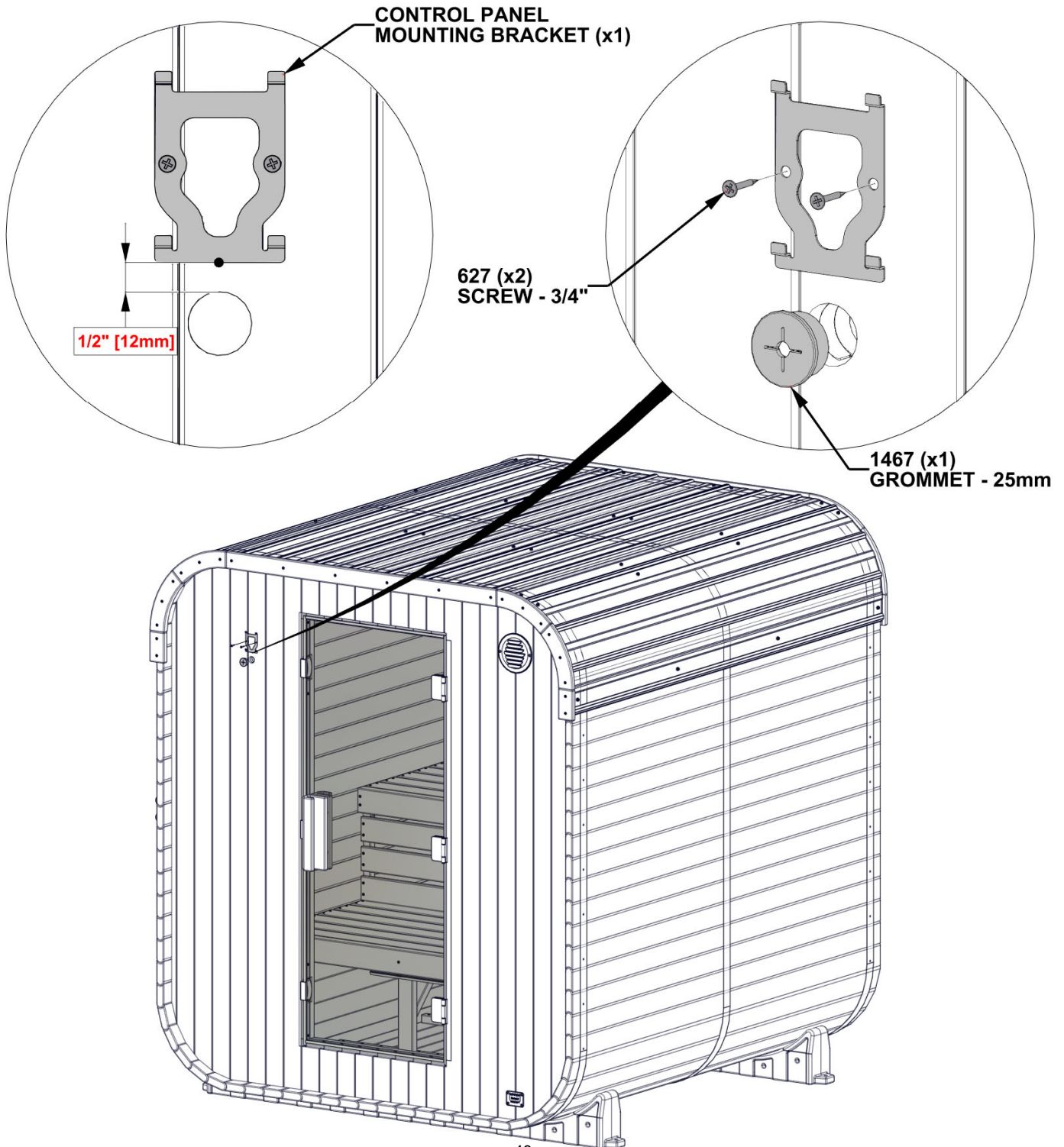

STEP 39 - CONTROL PANEL INSTALLATION



A4M05590-02 CONTROL PANEL
(x1)

CONTROL PANEL (x1)

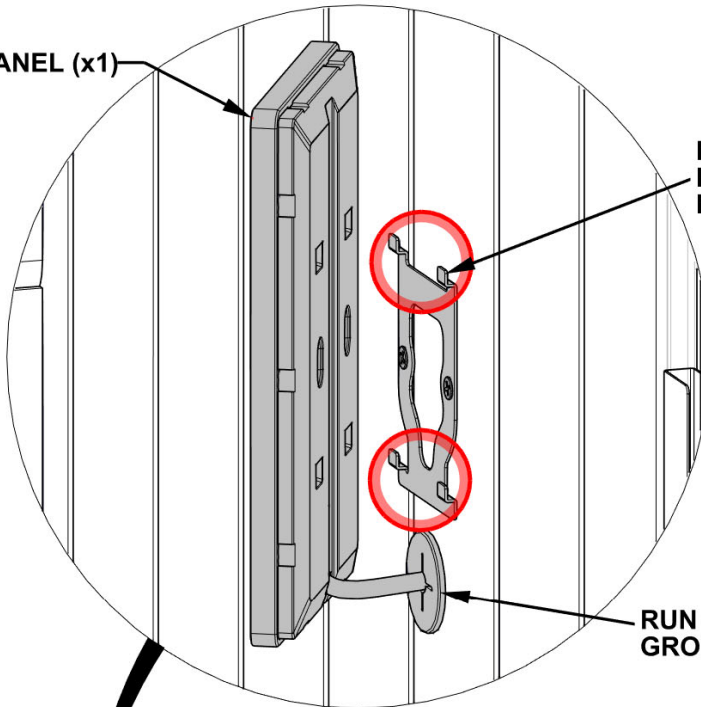

HANG CONTROL PANEL ON
HOOKS ON CONTROL PANEL
BRACKET AND SNAP INTO PLACE.

RUN CORD THROUGH
GROMMET.

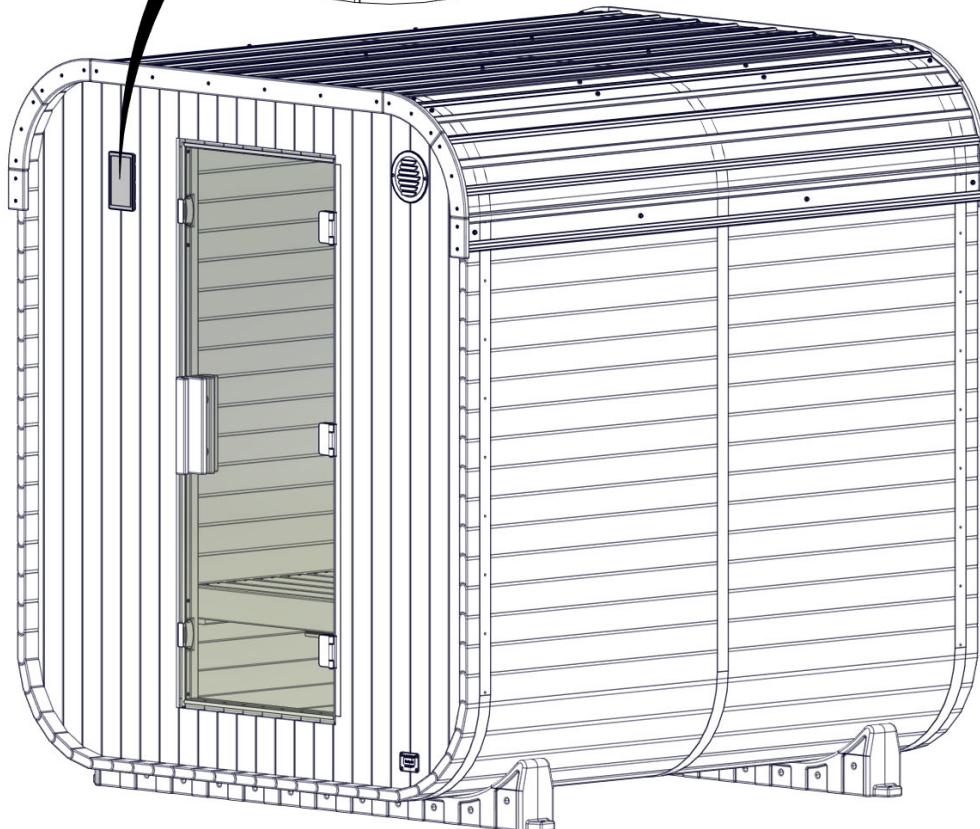

STEP 40 - CONTROL PANEL ASSEMBLY

QTY	PART NUMBER	DESCRIPTION
4	H101428	SCREW TFH 8X1 3/4 SS-BLK

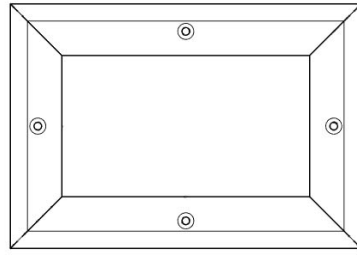

TF01 TRIM FRAME - W2A04797
(x1) 7/8"x5 9/16"x8 1/16" (22x142x204)

- PLACE TRIM FRAME ON CONTROL PANEL ENSURING IT SEATS AROUND THE CONTROL PANEL AND ATTACH AS SHOWN.

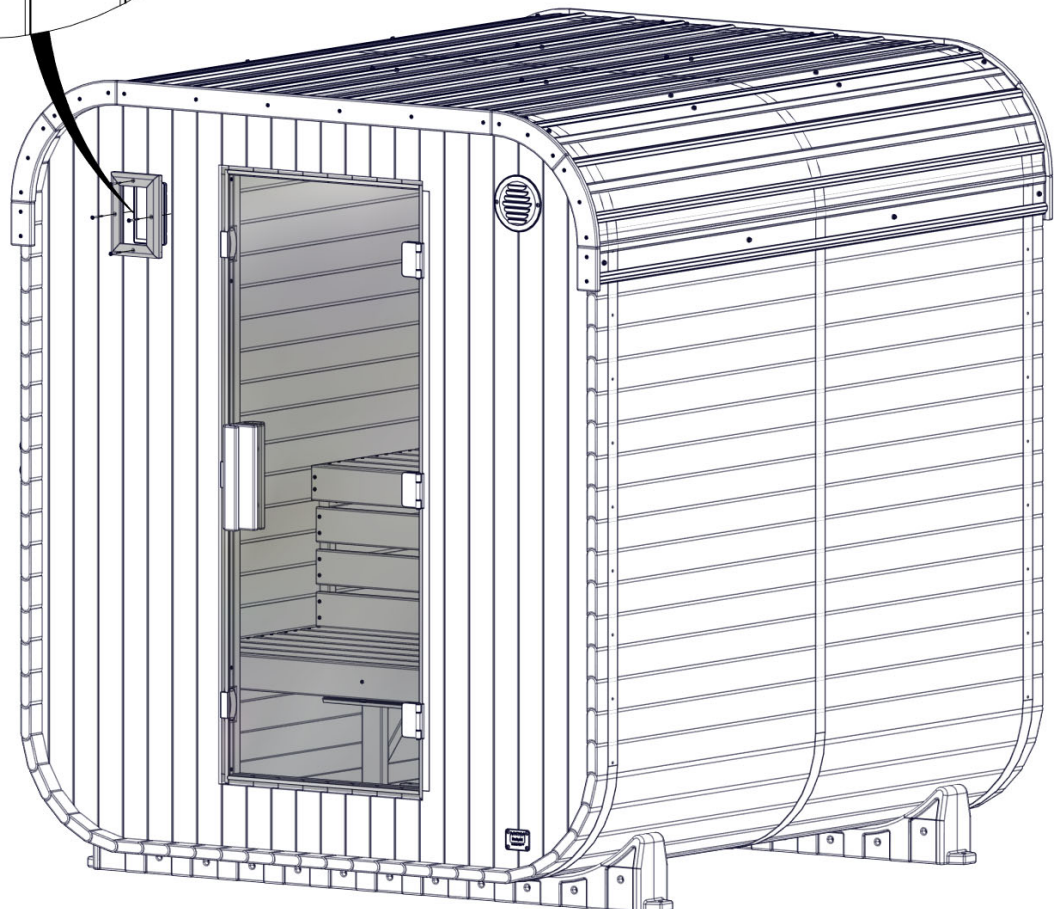
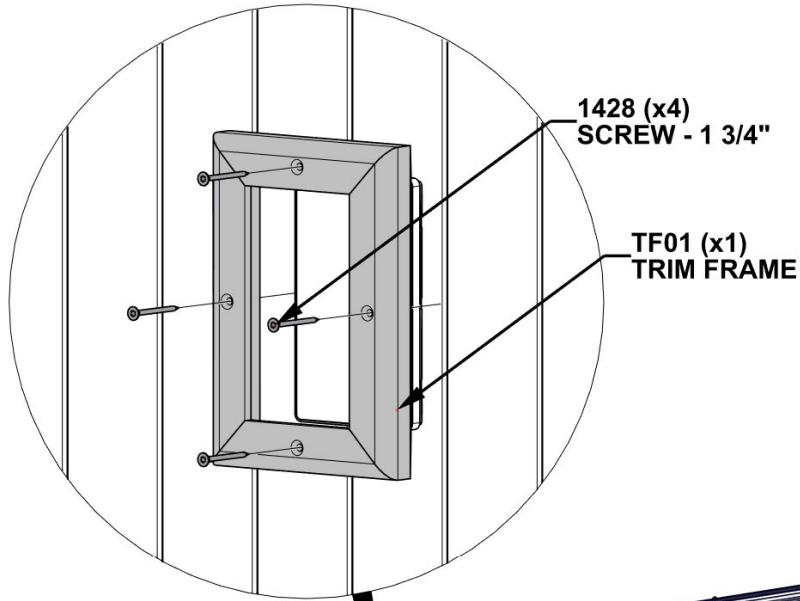

STEP 41 - WIREWAY ASSEMBLY

QTY	PART NUMBER	DESCRIPTION
4	H101429	SCREW TFH 8X2 SS-BLK



A4M05590-10 WIRING HARNESS (x1)

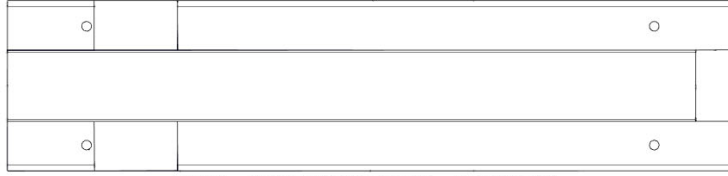

OG08 WIREWAY BOARD - W4L22040 (x1)
1 3/16"x3 3/8"x14 7/16" (30x86x367)

- CONNECT WIRING HARNESS TO CORD FROM STEP 39.
- HOLD CONNECTED CORDS UP TO THE TOP OF THE SAUNA, CENTER WIREWAY BOARD OVER HOLE IN FRONT WALL, AND ATTACH BOARD AS SHOWN.
- **BE CAUTIOUS WHEN INSERTING SCREWS TO PREVENT PINCHING OR PENETRATING CORDS.**

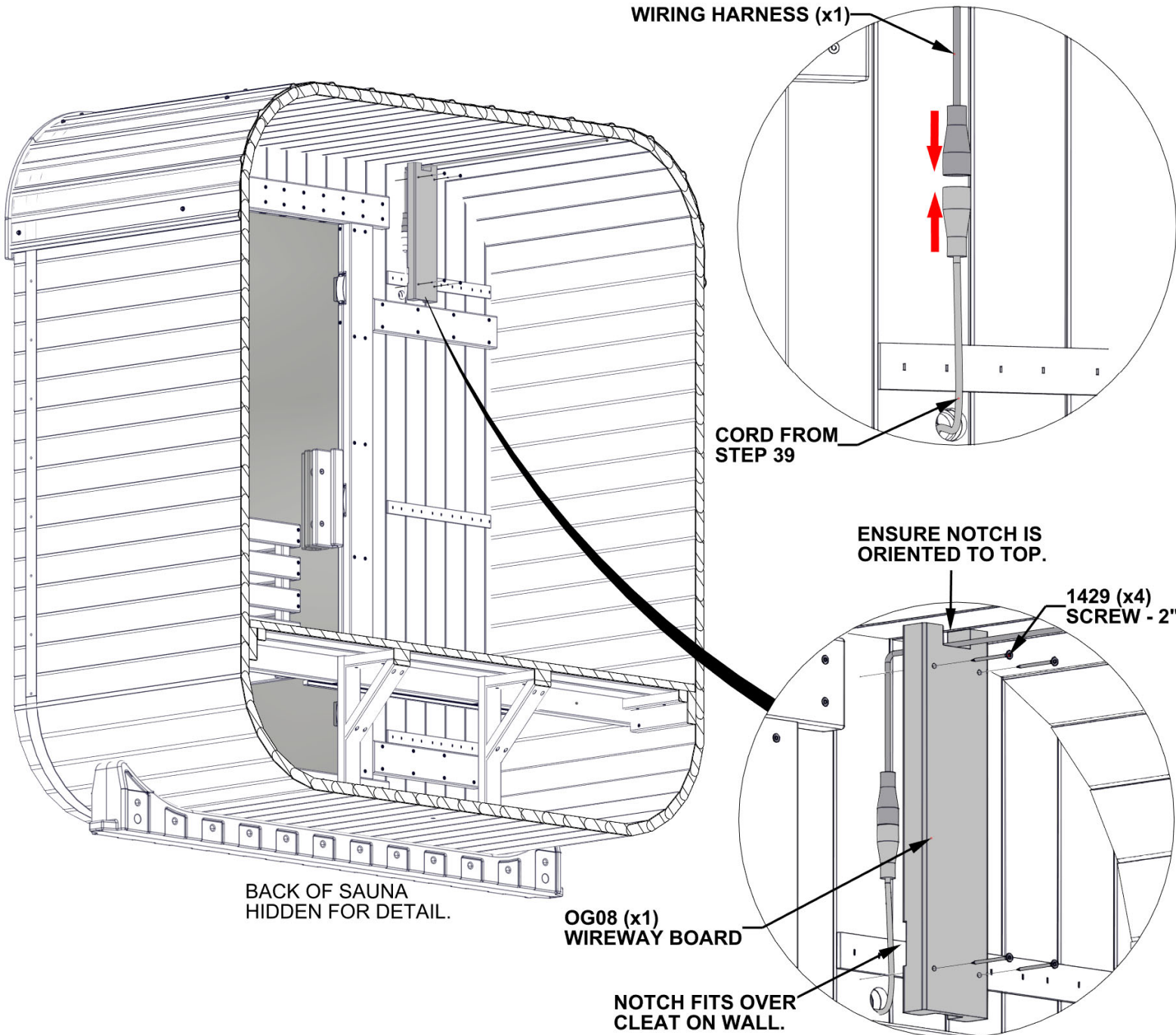

STEP 42 - TEMPERATURE SENSOR INSTALLATION

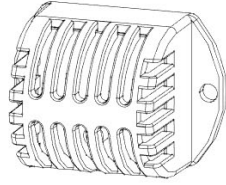

A4M05590-08 TEMPERATURE SENSOR
(x1)

- RUN CORD FROM PREVIOUS STEP THROUGH HOLE IN BACK WALL AS SHOWN.
- RUN CORD FOR TEMPERATURE SENSOR THROUGH HOLE, AND CAREFULLY LET HANG UNTIL IT IS ATTACHED LATER.

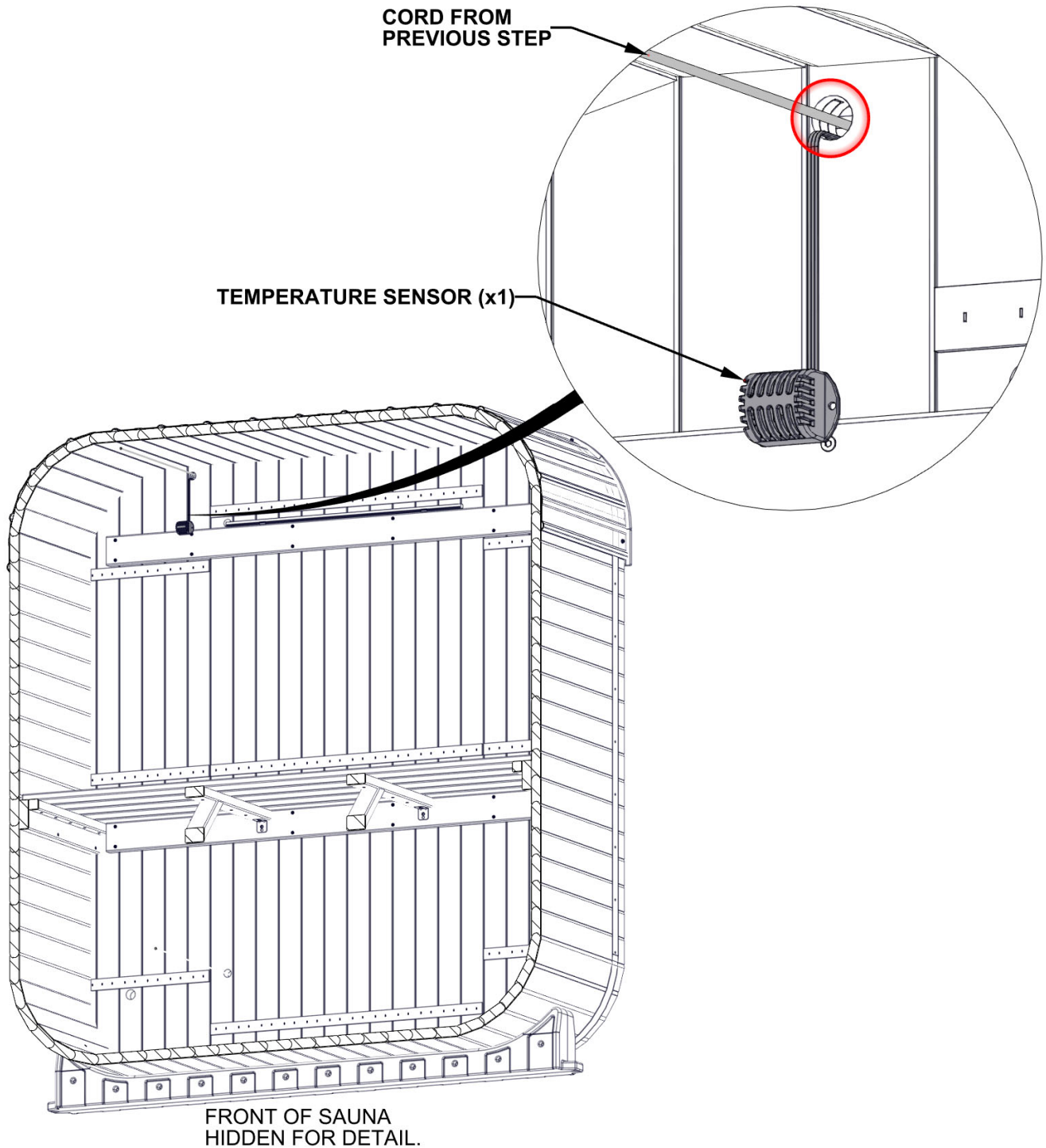

STEP 43 - WIREWAY ASSEMBLY

QTY	PART NUMBER	DESCRIPTION
4	H101429	SCREW TFH 8X2 SS-BLK
2	H101440	SCREW TWH 8x1 SS-BLK

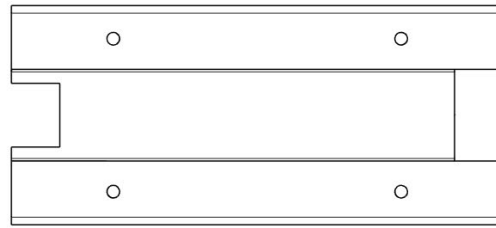

OG10 WIREWAY BOARD - W4L22042
(x1) 1 3/16"x3 3/8"x7 5/8" (30x86x193)

- HOLD CORDS UP TO THE TOP OF THE SAUNA, CENTER WIREWAY BOARD OVER HOLE IN BACK WALL, AND ATTACH BOARD AS SHOWN.
- ONCE WIREWAY BOARD IS ATTACHED. ATTACH TEMPERATURE SENSOR CENTERED OVER NOTCH AS SHOWN.
- **BE CAUTIOUS WHEN INSERTING SCREWS TO PREVENT PINCHING OR PENETRATING CORDS.**

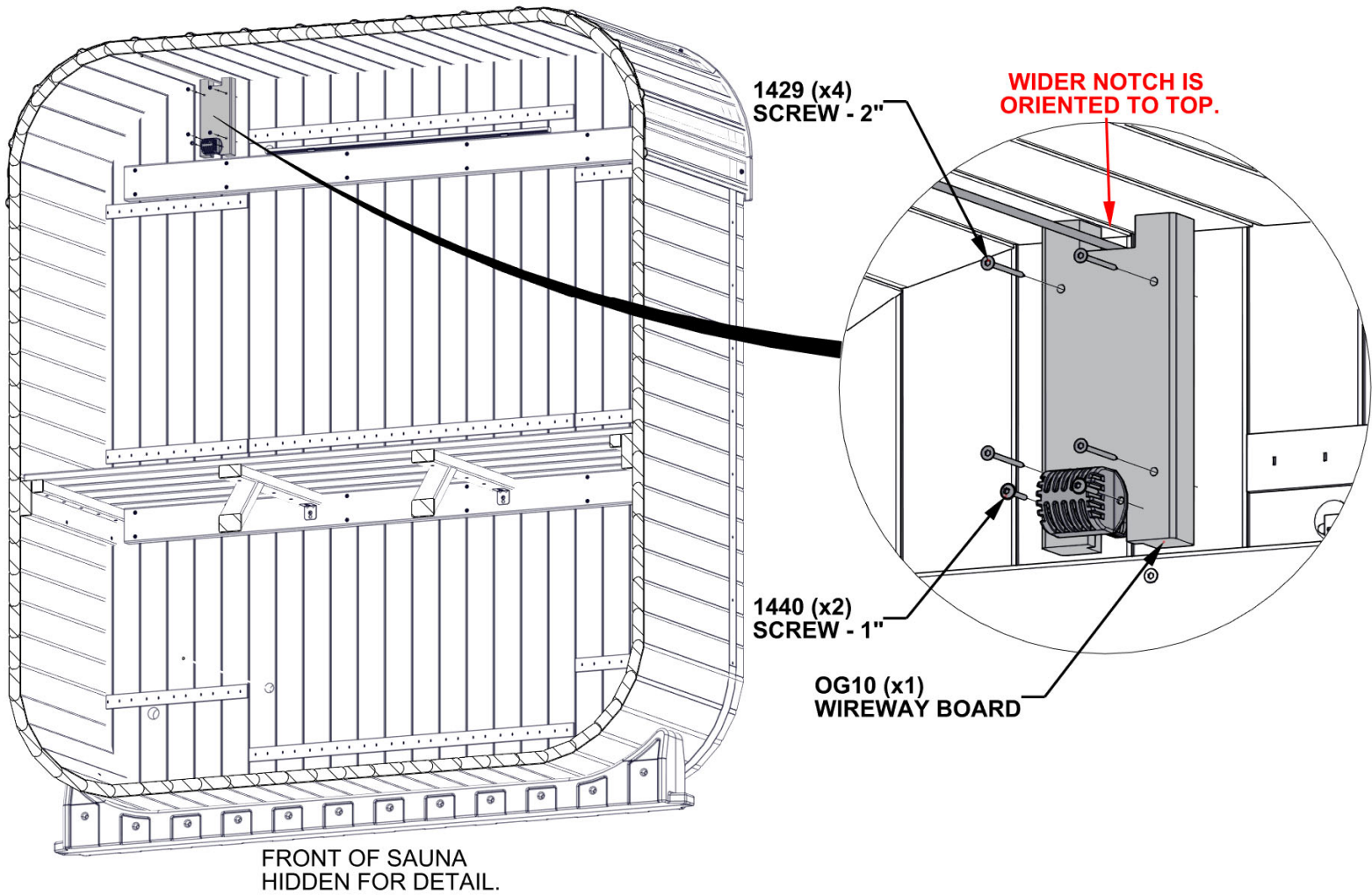

STEP 44 - WIREWAY ASSEMBLY

QTY	PART NUMBER	DESCRIPTION
12	H101429	SCREW TFH 8X2 SS-BLK



OG09 WIREWAY BOARD - W4L22041
(x1) 1 3/16"x3 3/8"x65 9/16" (30x86x1665)

- ENSURE CORD RESTS IN GROOVE IN THE TOP OF THE WIREWAY BOARD AS BOARD IS PUT INTO POSITION.
- ALIGN WITH PREVIOUSLY INSTALLED WIREWAY BOARDS ON THE FRONT AND BACK WALLS.
- ATTACH AS SHOWN.
- **BE CAUTIOUS WHEN INSERTING SCREWS TO PREVENT PINCHING OR PENETRATING CORDS.**

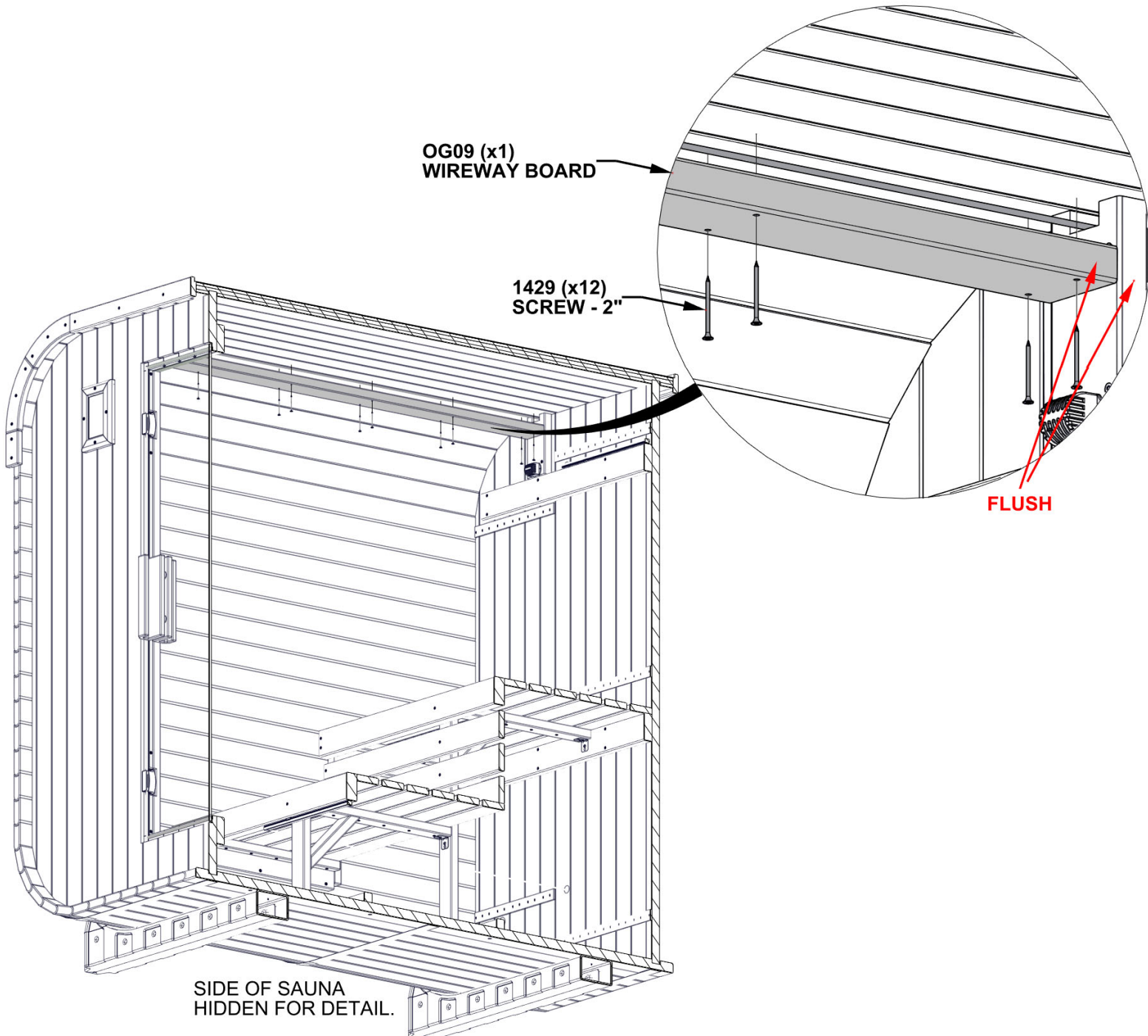

STEP 45 - CONTROL PANEL INSTALLATION

QTY	PART NUMBER	DESCRIPTION
3	H101440	SCREW TWH 8x1 SS-BLK

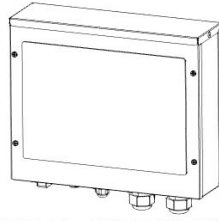

A4M05590-01 CONTROL PANEL BOX (x1)

- REMOVE COVER PLATE FROM CONTROL PANEL BOX.
- POSITION CONTROL PANEL BOX IN APPROXIMATE LOCATION 4 1/4" ABOVE THE THROUGH HOLE AS SHOWN.
- REATTACH COVER PLATE.

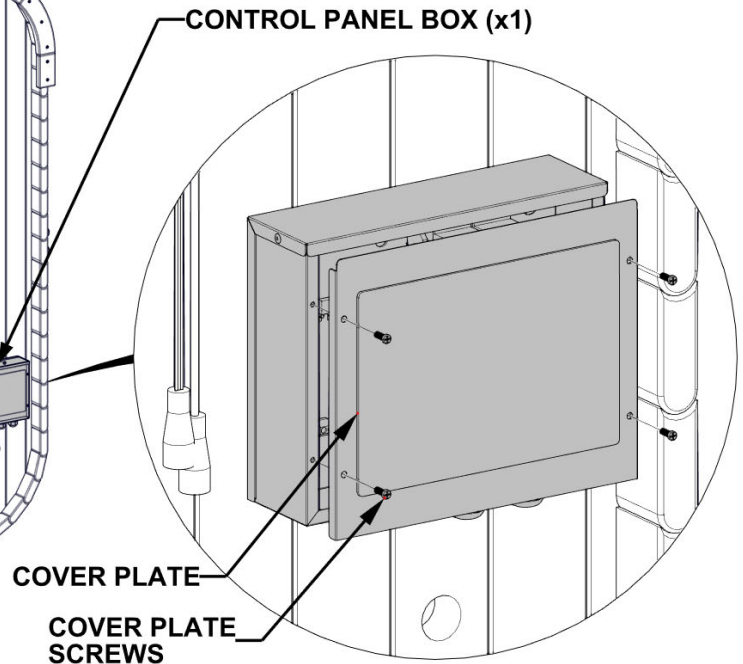
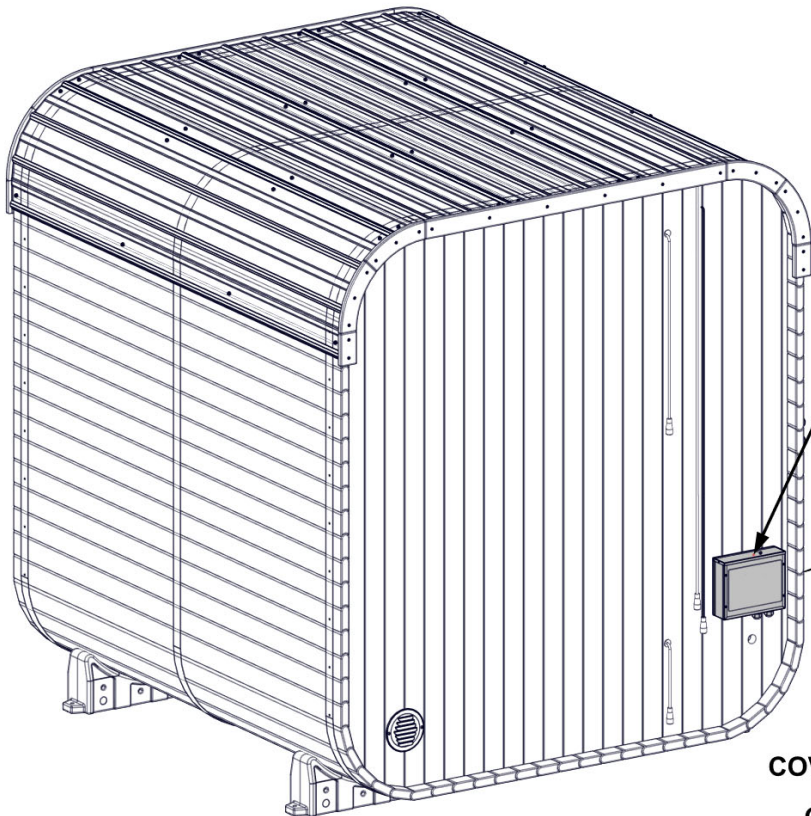
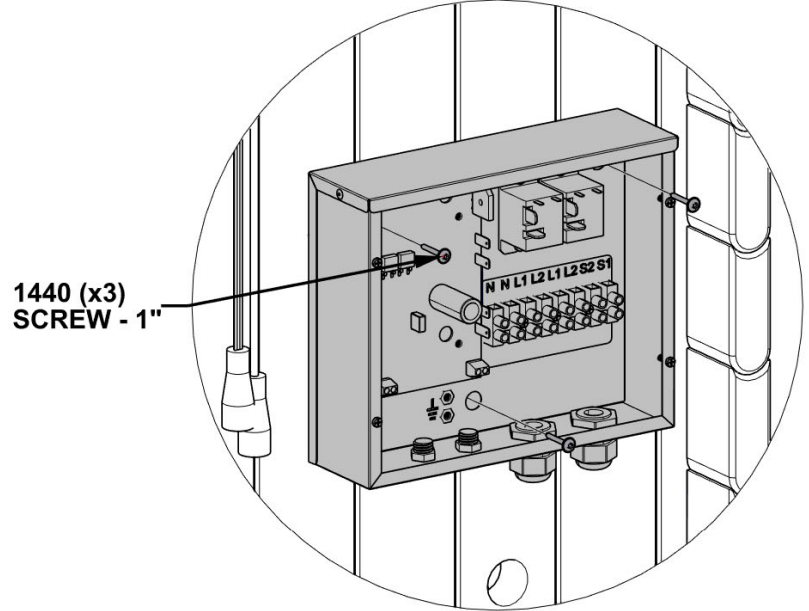
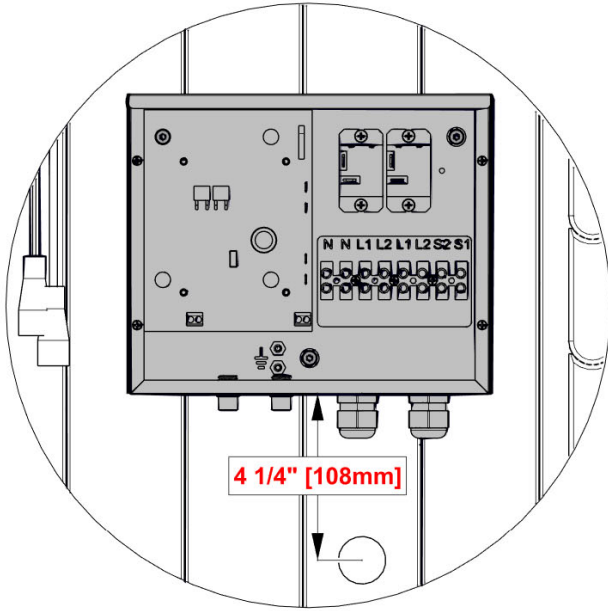

STEP 46 - GROMMET INSTALLATION

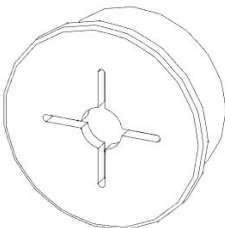

A6P01467 SILICON GROMMET 25mm
(x3)

- SLIDE GROMMET OVER LIGHT POWER CORDS AND INSERT INTO HOLES IN BACK WALL.

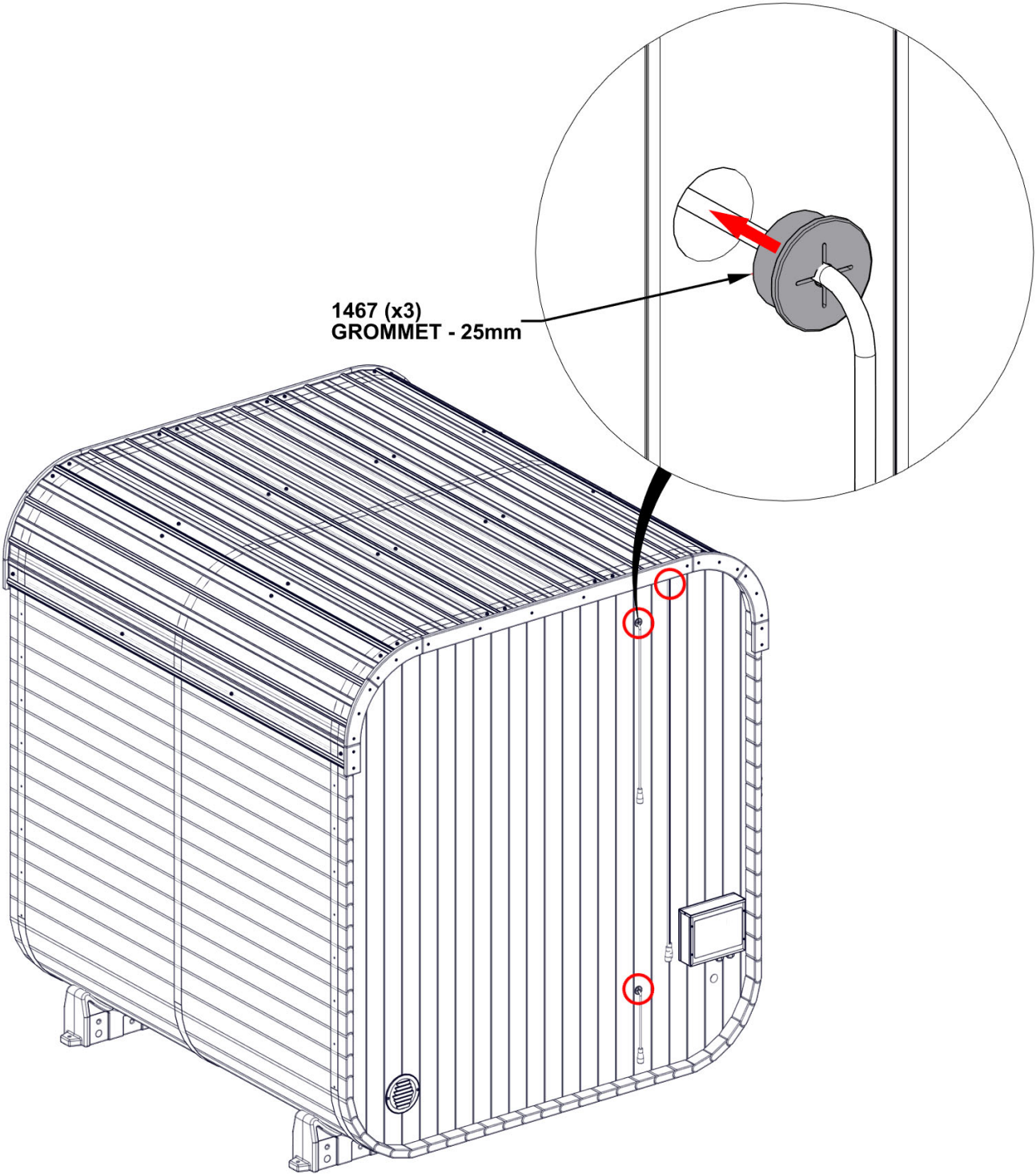

STEP 47 - ELECTRICAL

QTY	PART NUMBER	DESCRIPTION
8	H101409	SCREW PPH 4x1/2 BLK
6	H101440	SCREW TWH 8x1 SS-BLK

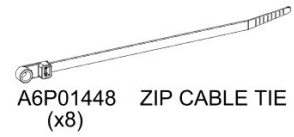
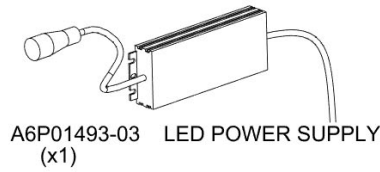
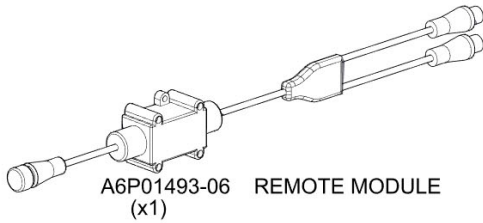

- LOCATE REMOTE MODULE AND POWER SUPPLY IN APPROXIMATE LOCATIONS.
- ENSURE REMOTE MODULE AND POWER SUPPLY ARE ORIENTED HORIZONTALLY WHEN ATTACHING.
- USE ZIP TIES WHERE NEEDED TO ATTACH AND ORGANIZE CORDS.

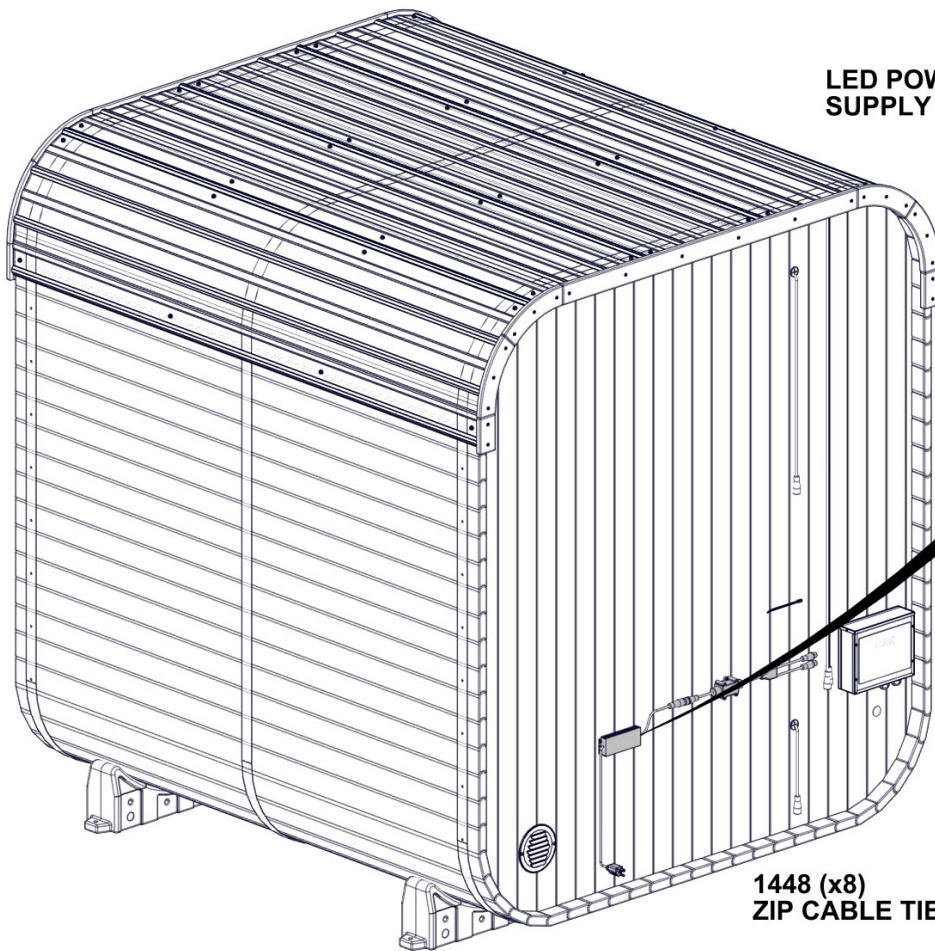
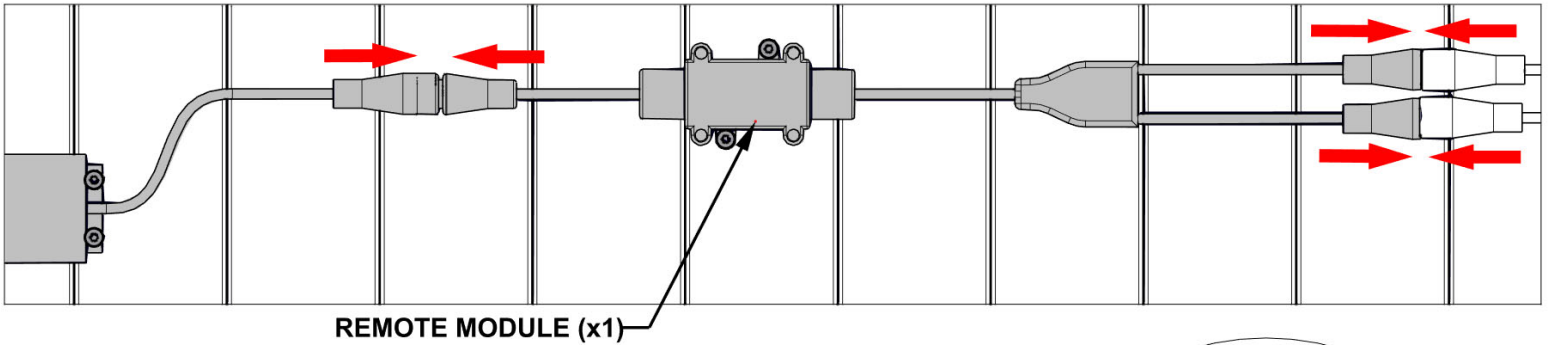

LED POWER SUPPLY (x1)

1440 (x6)
SCREW - 1"

1448 (x8)
ZIP CABLE TIE

1409 (x8)
SCREW - 1/2"

STEP 48 - THERMOMETER INSTALLATION

QTY	PART NUMBER	DESCRIPTION
1	H101424	SCREW TFH 8X1 SS-BLK

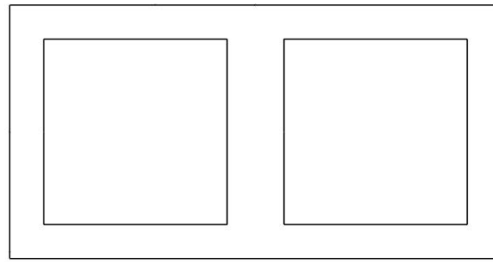

T01 THERMOMETER - W4L21965
(x1)

- INSERT SCREW INTO BACK WALL IN APPROXIMATE LOCATION SHOWN AND HANG THERMOMETER ON IT.

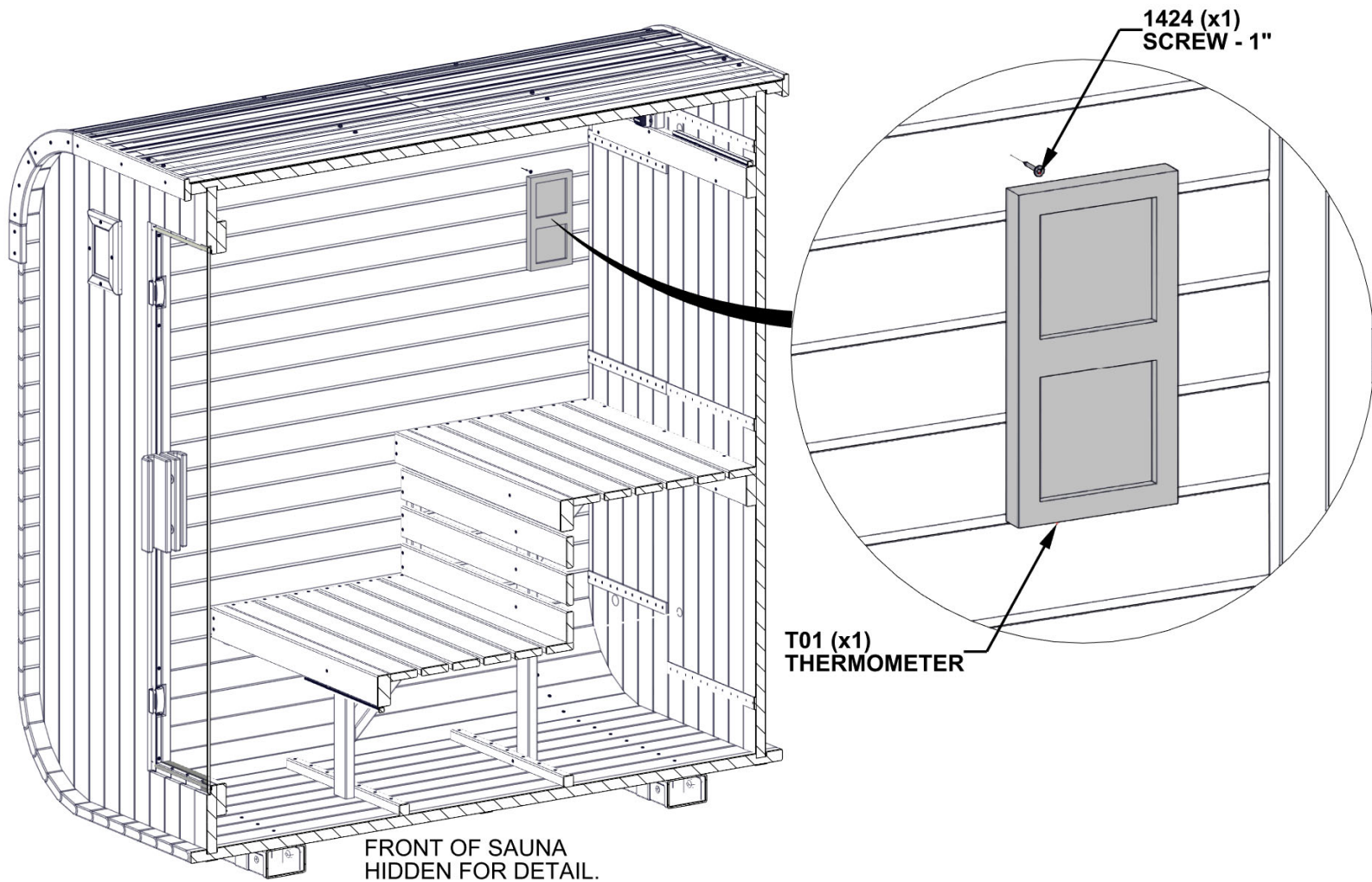

STEP 49 - TOWEL HANGER INSTALLATION

QTY	PART NUMBER	DESCRIPTION
4	H101423	SCREW TFH 8X7/8 SS-BLK

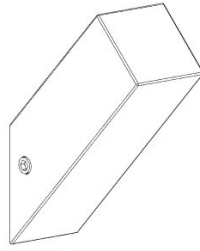

A4M05672 TOWEL HANGER
(x2)

- INSTALL TOWEL HANGERS AT ANY DESIRED LOCATION ON THE RIGHT SIDE.
- HOWEVER, DO NOT INSTALL SCREWS AT THE SEAMS OF PANEL BOARDS.
- ENSURE TOWEL HANGERS ARE NOT TOO CLOSE TO THE DOOR WHEN FULLY OPEN TO AVOID CONTACT AND POTENTIAL BREAKAGE.

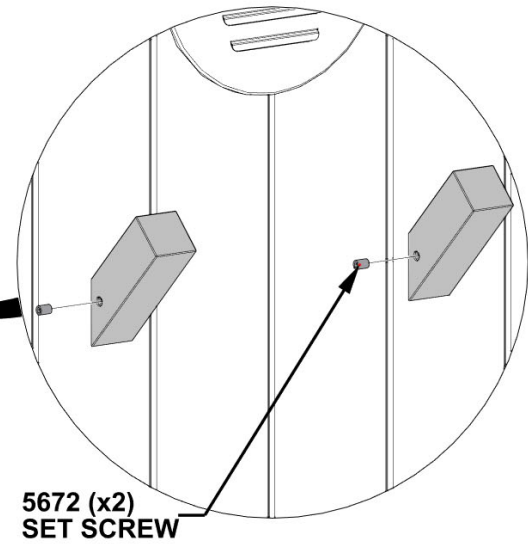
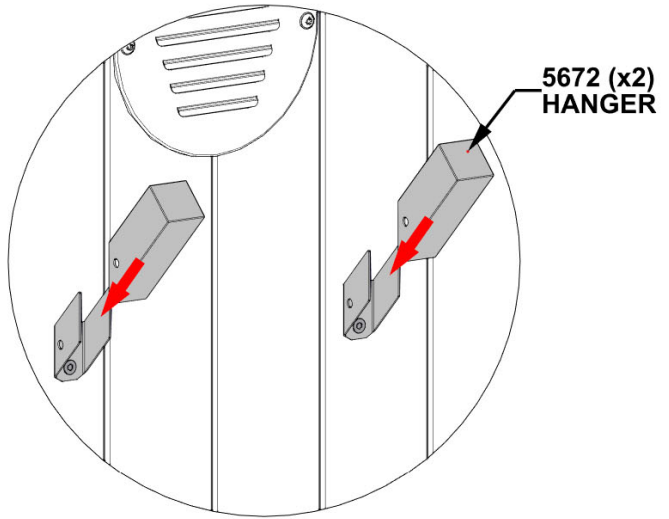
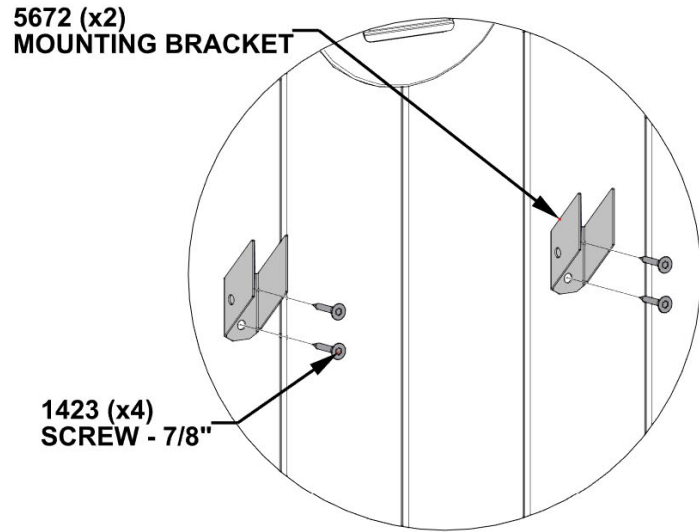

STEP 50 - HEATER INSTALLATION

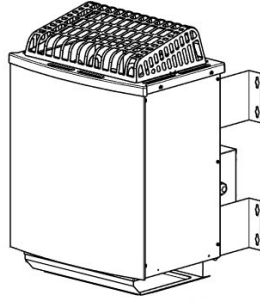

9250253 9KW ELECTRIC SAUNA HEATER
(x1)

- CAUTION: IMPROPER INSTALLATION OF THE HEATER COULD CAUSE HEATER TO FALL CAUSING BURNS OR OTHER INJURIES.
- DANGER! TURN OFF POWER TO THE HEATER AT THE BREAKER BEFORE BEGINNING INSTALLATION OR PERFORMING ANY MAINTENANCE. FAILURE TO TURN OFF THE POWER CAN RESULT IN ELECTROCUTION AND EVEN DEATH.
- LICENSED ELECTRICIAN REQUIRED FOR HEATER INSTALLATION - SEE HEATER INSTRUCTIONS.
- HANG HEATER ONTO SCREWS, ENSURING ALL 8 SCREWS ARE ALIGNED INTO THE SLOTS IN THE HEATER AS SHOWN.

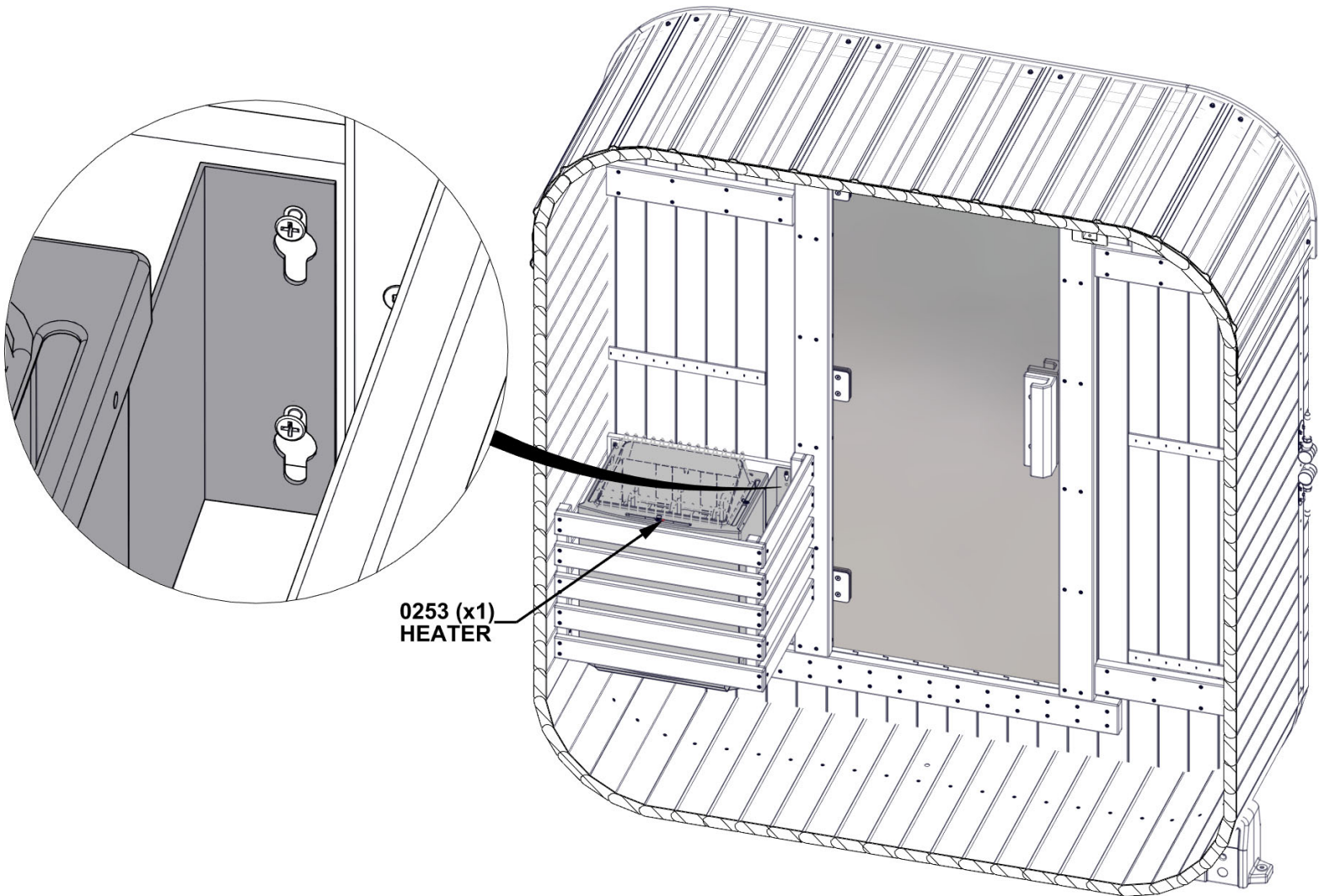

STEP 51 - ELECTRICAL

QTY	PART NUMBER	DESCRIPTION
2	H101409	SCREW PPH 4x1/2 BLK

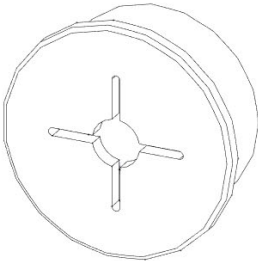

A6P01468 30mm SILICON GROMMET
(x1)



A6P01490 SAUNA POWER WIRE
(x1)



A6P01448 ZIP CABLE TIE
(x2)

- USE PROVIDED GROMMET FOR POWER WIRE.
- SEE HEATER INSTRUCTIONS FOR INSTALLATION.
- WILL NEED TO REMOVE CONDUIT FITTING TO FEED SAUNA POWER WIRE THROUGH GROMMET.
- USE ZIP TIES TO SECURE AND ORGANIZE POWER WIRE.

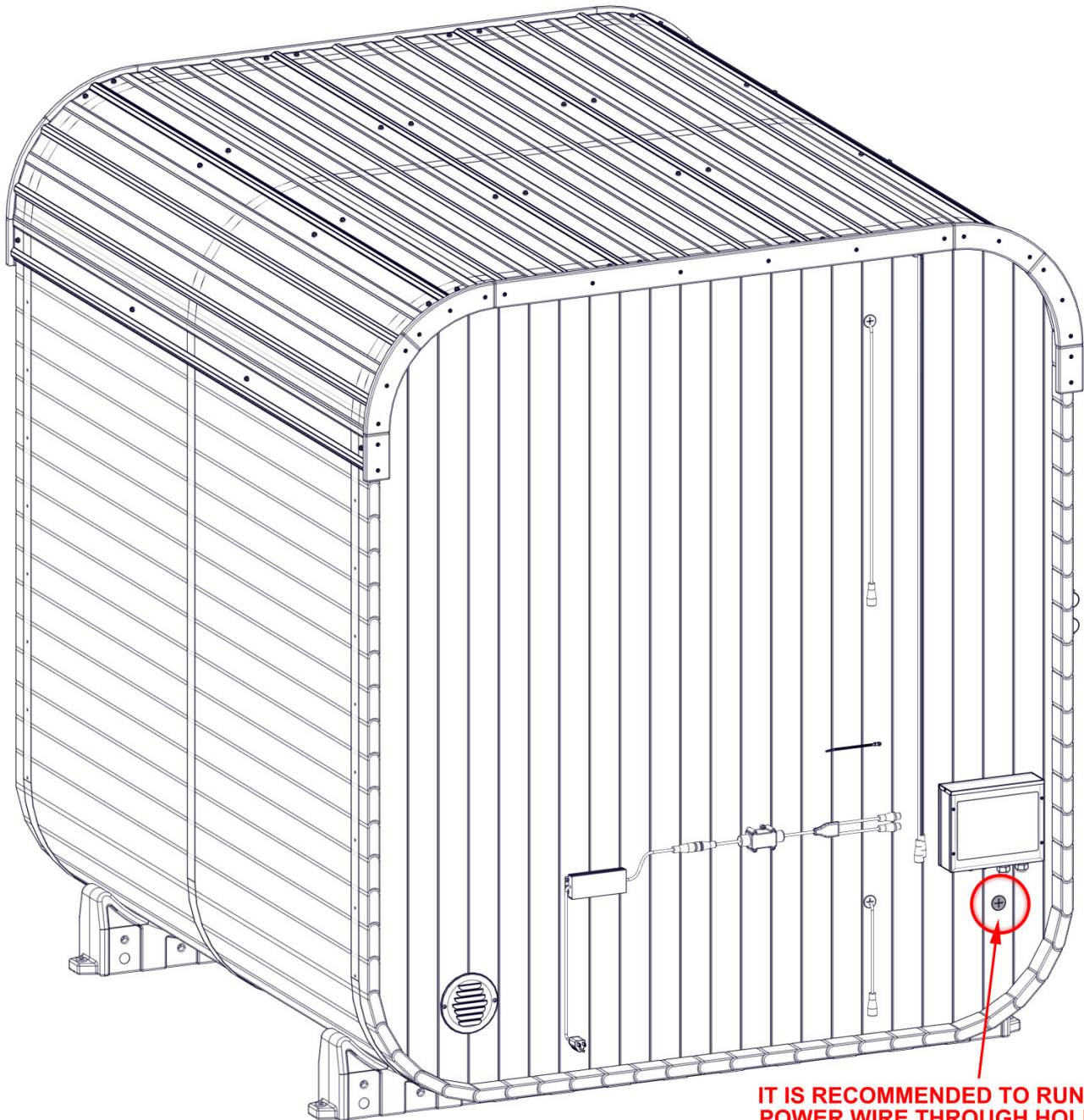

IT IS RECOMMENDED TO RUN SAUNA POWER WIRE THROUGH HOLE FROM OUTSIDE TO INSIDE OF SAUNA AND ATTACH THE END OF THE SAUNA POWER WIRE NEXT TO THE HEATER WITH ZIP TIES. THIS AVOIDS INTERFERENCE WITH BENCH SEATING.

STEP 52 - CLEANING

ONCE THE ASSEMBLY IS COMPLETE, SWEEP AND VACUUM THE INSIDE OF THE SAUNA. WIPE DOWN THE ENTIRE SAUNA WITH A DAMP CLOTH TO REMOVE ANY REMAINING DIRT, DUST, AND DEBRIS.

DO NOT USE CHEMICAL-BASED CLEANING AGENTS INSIDE THE SAUNA.

