

CONDO PACK ARCHITECTURAL LOUVERS (GRILLE)

CAGMHA - for P-C CondoPack
 CAGMMA - for P-S CondoPack
 CAGMEA - for P-E CondoPack



INSTALLATION INSTRUCTIONS

Ensure all parts are in the kit before proceeding. Do not proceed if parts are missing.

PROCEDURE

(Please read entire instructions first.)

KIT CONTAINS :

| QTY | DESCRIPTION | PART # |
|-----|--|------------------------|
| 1 | GRILLE, ARCHITECTURAL LOUVERS | CAGMHA, CAGMMA, CAGMEA |
| 8 | SCREW, #8 X 1" HEX DRIVE TEKS SS | W570-0204 |
| 8 | WASHER, 0.174ID X 0.375OD X 0.125" THK NYL 6/6 | W735-0062 |
| 1 | LEAFLET, ARCHITECTURAL GRILLE INSTALL (CP) | W415-2253 |

ARCHITECTURAL GRILLE IS DESIGNED TO BE INSTALLED ONTO A WALL SLEEVE PRIOR TO CONDOPACK INSTALLATION. IT IS RECOMMENDED THAT THIS STEP IS PERFORMED AFTER CONSTRUCTION PHASE HAS BEEN COMPLETED.

⚠ IMPORTANT ⚠

TESTING HAS SHOWN THAT THE INSTALLATION OF ARCHITECTURAL GRILLE AFFECTS THE NORMAL OPERATION OF THE CONDOPACK UNIT UNDER CERTAIN OPERATING CONDITIONS. THE FACTORY INSTALLED **UPPER STAMPED GRILLE MUST BE REMOVED** FROM THE CONDOPACK CABINET, PRIOR TO UNIT INSTALLATION INTO A WALL SLEEVE. NO UNAPPROVED ARCHITECTURAL GRILLE IS ALLOWED. UNAPPROVED ARCHITECTURAL GRILLE AND IMPROPER INSTALLATION WILL LEAD TO DETERIORATION OF THE PERFORMANCE AND PREMATURE FAILURE DUE TO ADDED RESTRICTION TO AIR FLOW.

1

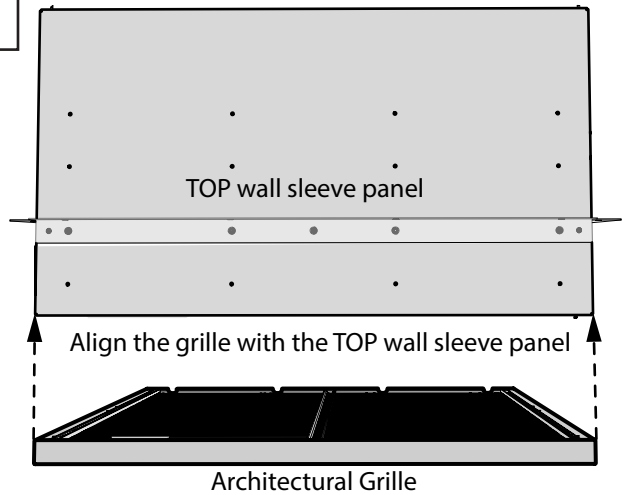

STEP 1.

Align the architectural grille with the top wall sleeve panel.

2

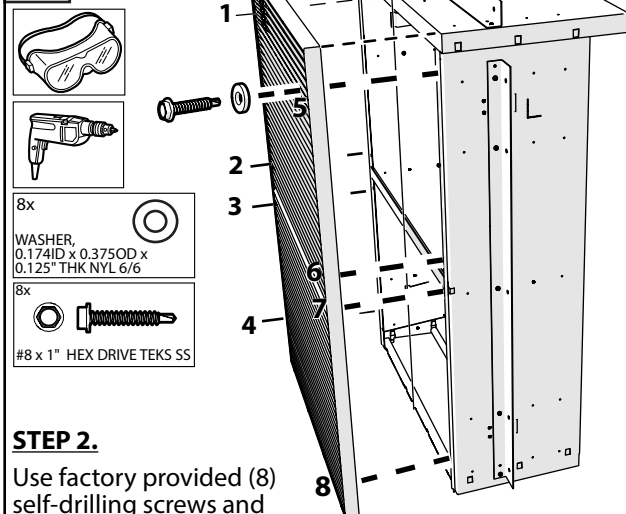

STEP 2.

Use factory provided (8) self-drilling screws and (8) washers to fasten the grille onto wall sleeve. **Use only factory provided plastic washer with screws. If not used, the screws will damage the cabinet and obstruct the removal of the cabinet at the end of life cycle.**

3

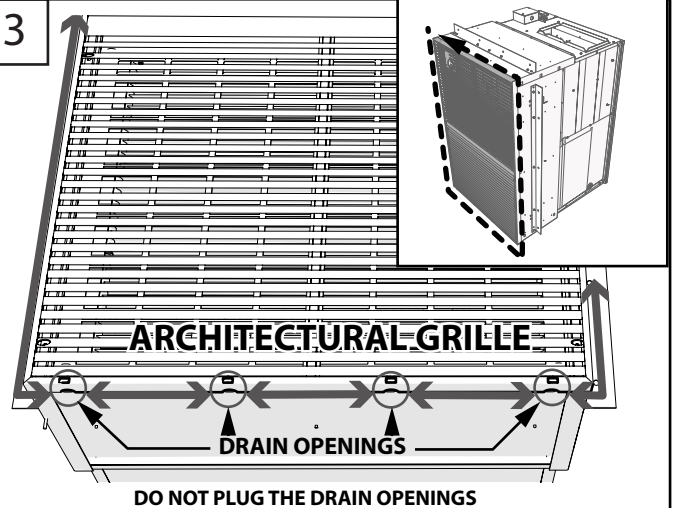

STEP 3.

Ensure wall sleeve is sealed properly according to wall sleeve installation procedure. Caulk all seams between the grille and the FINISHED exterior walls. Seal the spaces using non-hardening caulking compound. All seals must be weather tight to prevent entrance of moisture and water into the building. Care must be taken not to plug the **drain openings**.

⚠ IMPORTANT ⚠

THE GRILLE MUST BE SEALED ON ALL FOUR SIDES. IN ORDER TO PREVENT WATER RUNOFF DIRECTLY ONTO THE FINISH WALL, IT IS RECOMMENDED TO INSTALL FIELD-SUPPLIED FLASHING UNDERNEATH THE BOTTOM OF THE LOUVER.



⚠ IMPORTANT ⚠

ARCHITECTURAL GRILLE IS DESIGNED TO BE INSTALLED ONTO A WALL SLEEVE **PRIOR** TO CONDOPACK INSTALLATION. IT IS RECOMMENDED THAT THIS STEP IS PERFORMED **AFTER** CONSTRUCTION PHASE HAS BEEN COMPLETED.
FOR COMPLETE INSTALLATION PROCEDURE REFER TO CONDOPACK INSTALLATION MANUAL.

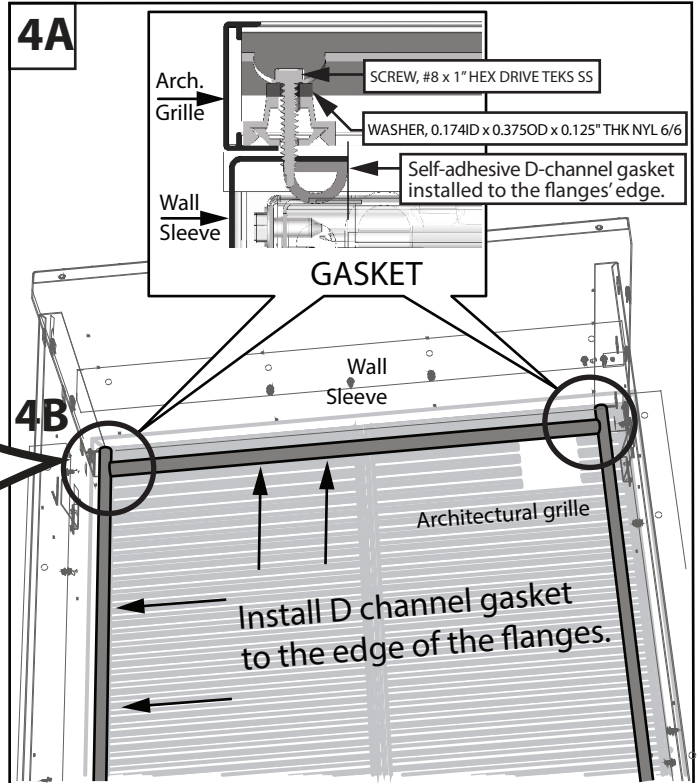
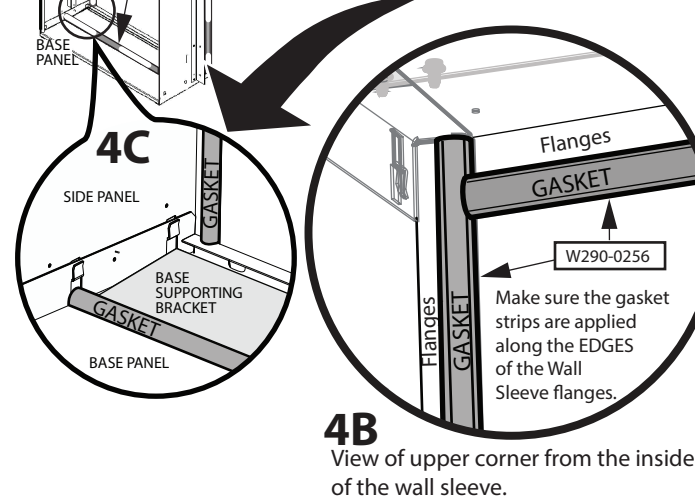
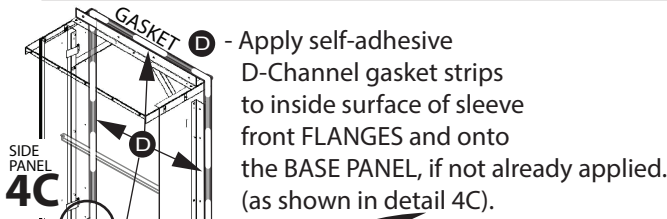

5 ⚠ IMPORTANT ⚠

THE FACTORY INSTALLED UPPER STAMPED GRILLE (**FOR CAGMMA & CAGMMA39 ONLY**) MUST BE REMOVED FROM THE CONDOPACK CABINET, PRIOR TO UNIT INSTALLATION INTO THE WALL SLEEVE.

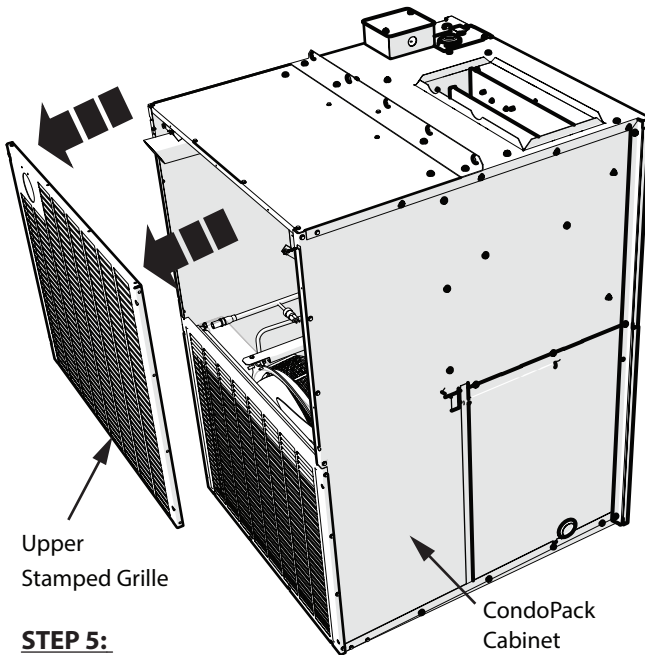

STEP 5: Remove factory installed upper stamped grille from the CondoPack cabinet as shown.
- Discard upper stamped grille.

STEP 4: Apply D-channel gasket (W290-0256, included with CondoPack cabinet), if not already applied, as per detail 4A, 4B, 4C. Make sure all the surfaces (where the gasket is to be applied) are clean, dry, and warm (promotes better adhesion).

CONTINUED ON NEXT PAGE

5A

Bracket (W080-2068)

Upper Stamped Grill (W350-0030)

STEP 5A:
 FOR **CAGMHA**, REMOVE W350-0030 AND DISCARD IT WHILE BRACKET W080-2068 REMAINS IN THE SAME POSITION PRIOR TO UNIT INSTALLATION INTO THE WALL SLEEVE.

7

Wall Sleeve

Cabinet

SEAL HERE

SEAL ON TOP

SEAL LEFT SIDE

SEAL RIGHT SIDE

SEAL BOTTOM

STEP 7:
 Fill the clearance space between the sleeve and the cabinet (FIG. 7) with non-hardening caulking compound or non-expanding insulation foam as a protection against the moisture and air infiltration.

⚠ IMPORTANT ⚠
 THE CLEARANCE SPACE BETWEEN THE WALL SLEEVE AND THE CABINET MUST BE **COMPLETELY SEALED ON ALL FOUR SIDES** (FIG. 7) IN ORDER TO PREVENT THE MOISTURE AND AIR INFILTRATION.
 FOR COMPLETE INSTRUCTIONS REFER TO CONDO PACK INSTALLATION MANUAL

⚠ WARNING ⚠

7A

SEAL CORNERS

SEAL ON BOTH SIDES

CABINET

Wall Sleeve

SEAL BOTTOM

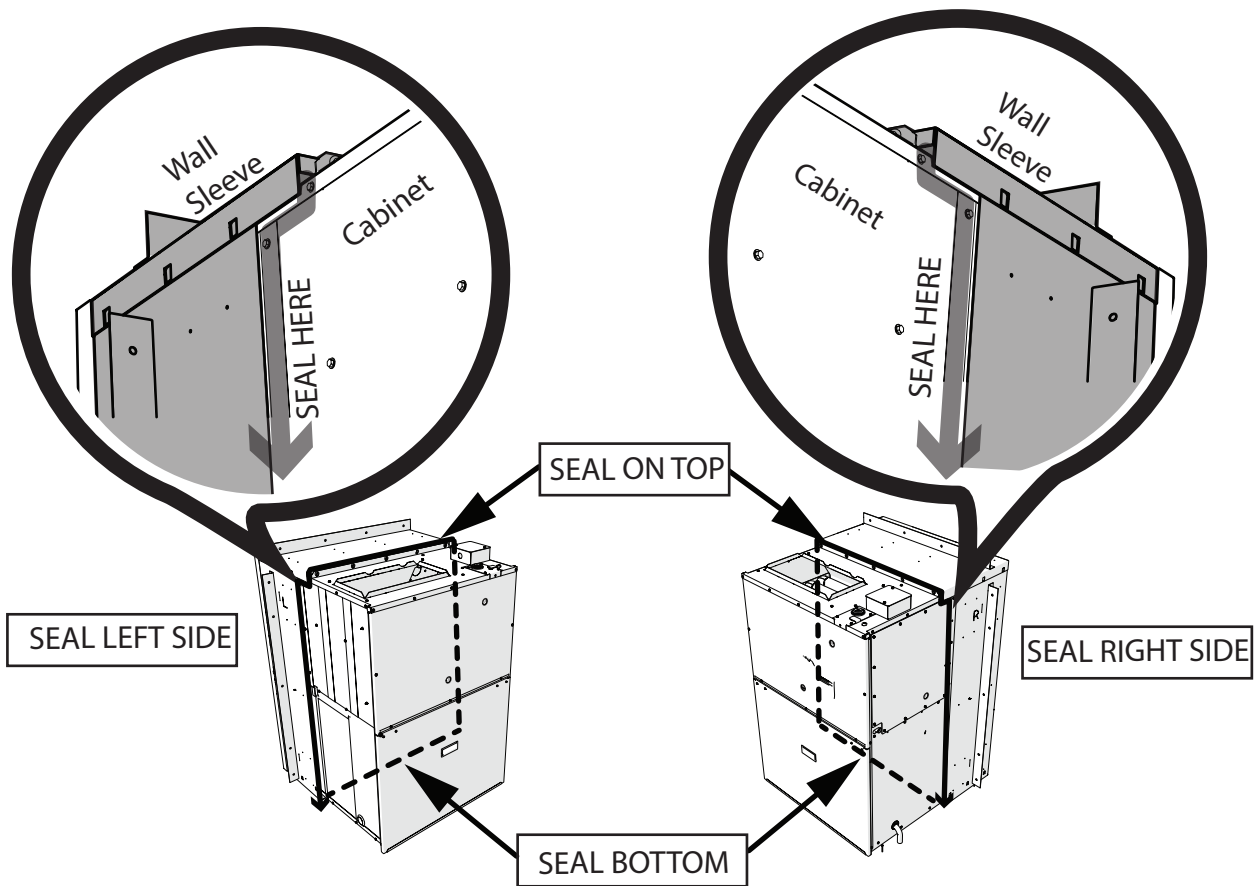

STEP 7:

Fill the clearance space between the sleeve and the cabinet (FIG. 7) with non-hardening caulking compound or non-expanding insulation foam as a protection against the moisture and air infiltration.

⚠ IMPORTANT ⚠

THE CLEARANCE SPACE BETWEEN THE WALL SLEEVE AND THE CABINET MUST BE **COMPLETELY SEALED ON ALL FOUR SIDES** (FIG. 7) IN ORDER TO PREVENT THE MOISTURE AND AIR INFILTRATION.

FOR COMPLETE INSTRUCTIONS REFER TO CONDO PACK INSTALLATION MANUAL

⚠ WARNING ⚠

THESE INSTRUCTIONS ARE INTENDED AS AN AID TO QUALIFIED SERVICE PERSONNEL FOR PROPER INSTALLATION, ADJUSTMENT AND OPERATION OF THE UNIT. READ THESE INSTRUCTIONS THOROUGHLY BEFORE ATTEMPTING INSTALLATION OR OPERATION. IMPROPER INSTALLATION, ADJUSTMENT, SERVICE, OR MAINTENANCE CAN CAUSE PROPERTY DAMAGE, PERSONAL INJURY, OR DEATH. CONSULT A QUALIFIED INSTALLER OR SERVICE AGENCY FOR INFORMATION AND ASSISTANCE.

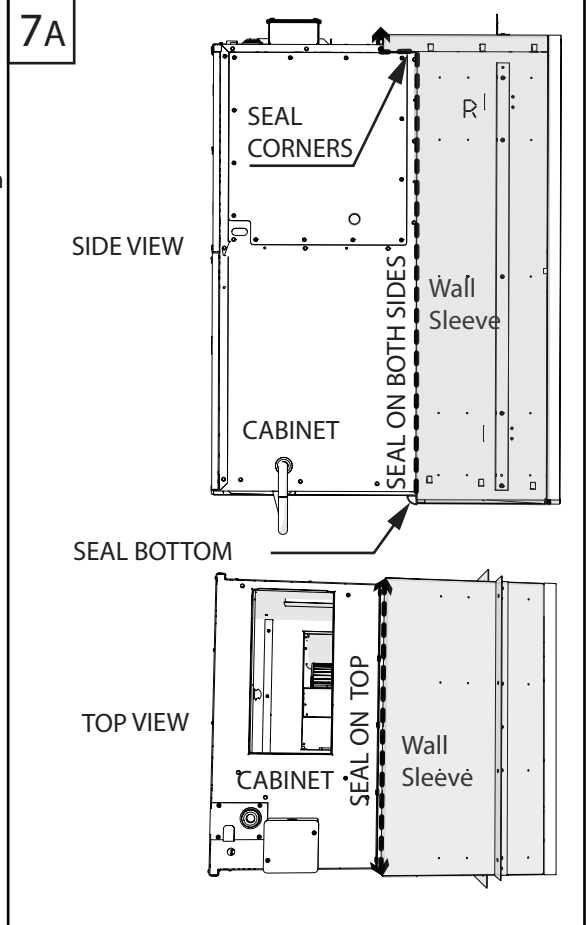

NAPOLEON CELEBRATING OVER 40 YEARS OF HOME COMFORT PRODUCTS



7200, Route Transcanadienne, Montréal, Québec H4T 1A3
24 Napoleon Road, Barrie, Ontario, Canada L4M 0G8
214 Bayview Drive, Barrie, Ontario, Canada L4N 4Y8
103 Miller Drive, Crittenden, Kentucky, USA 41030

Phone: 1-866-820-8686
napoleon.com

Wolf Steel Ltd., 24 Napoleon Rd., Barrie, ON L4M 0G8 Canada • phone 866-820-8686 • www.napoleon.com

Quality System Certified To
ISO
9001-2015

W415-2253 / C-0 / 10.21.2025