

PALMGREN®

17" VARIABLE SPEED DRILL PRESS



Read carefully and follow all safety rules and operating instructions before first use of this product.





Table of Contents

Important Safety Information	2	Operating Instructions	8
Specifications	5	Maintenance and Servicing	12
Setup - Before Use	5		

SAFETY

SETUP

WARNING SYMBOLS AND DEFINITIONS

	This is the safety alert symbol. It is used to alert you to potential personal injury hazards. Obey all safety messages that follow this symbol to avoid possible injury or death.
	Indicates a hazardous situation which, if not avoided, will result in death or serious injury.
	Indicates a hazardous situation which, if not avoided, could result in death or serious injury.
	Indicates a hazardous situation which, if not avoided, could result in minor or moderate injury.
	Addresses practices not related to personal injury.

OPERATION

MAINTENANCE

IMPORTANT SAFETY INFORMATION

General Tool Safety Warnings

WARNING

Read all safety warnings and instructions.
Failure to follow the warnings and instructions may result in electric shock, fire and/or serious injury.
Save all warnings and instructions for future reference.

- KEEP GUARDS IN PLACE and in working order.
- REMOVE ADJUSTING KEYS AND WRENCHES. Form habit of checking to see that keys and adjusting wrenches are removed from tool before turning it on.
- KEEP WORK AREA CLEAN. Cluttered areas and benches invite accidents.
- DON'T USE IN DANGEROUS ENVIRONMENT. Don't use power tools in damp or wet locations, or expose them to rain. Keep work area well lighted.
- KEEP CHILDREN AWAY. All visitors should be kept safe distance from work area.
- MAKE WORKSHOP KID PROOF with padlocks, master switches, or by removing starter keys.
- DON'T FORCE TOOL. It will do the job better and safer at the rate for which it was designed.
- USE RIGHT TOOL. Don't force tool or attachment to do a job for which it was not designed.

Table A: RECOMMENDED MINIMUM WIRE GAUGE FOR EXTENSION CORDS (120 VOLT)

NAMEPLATE AMPERES (at full load)	EXTENSION CORD LENGTH			
	25'	50'	100'	150'
0 – 6	18	16	16	14
6.1 – 10	18	16	14	12
10.1 – 12	16	16	14	12
12.1 – 16	14	12	Do not use.	

- USE PROPER EXTENSION CORD. Make sure your extension cord is in good condition. When using an extension cord, be sure to use one heavy enough to carry the current your product will draw. An undersized cord will cause a drop in line voltage resulting in loss of power and overheating. Table A shows the correct size to use depending on cord length and nameplate ampere rating. If in doubt, use the next heavier gauge. The smaller the gauge number, the heavier the cord.

General Tool Safety Warnings (continued)

10. **WEAR PROPER APPAREL.** Do not wear loose clothing, gloves, neckties, rings, bracelets, or other jewelry which may get caught in moving parts. Nonslip footwear is recommended. Wear protective hair covering to contain long hair.
11. **ALWAYS USE SAFETY GLASSES.** Also use face or dust mask if cutting operation is dusty. Everyday eyeglasses only have impact resistant lenses, they are NOT safety glasses.
12. **SECURE WORK.** Use clamps or a vise to hold work when practical. It's safer than using your hand and it frees both hands to operate tool.
13. **DON'T OVERREACH.** Keep proper footing and balance at all times.
14. **MAINTAIN TOOLS WITH CARE.** Keep tools sharp and clean for best and safest performance. Follow instructions for lubricating and changing accessories.
15. **DISCONNECT TOOLS** before servicing; when changing accessories, such as blades, bits, cutters, and the like.
16. **REDUCE THE RISK OF UNINTENTIONAL STARTING.** Make sure switch is in off position before plugging in.
17. **USE RECOMMENDED ACCESSORIES.** Consult the owner's manual for recommended accessories. The use of improper accessories may cause risk of injury to persons.
18. **NEVER STAND ON TOOL.** Serious injury could occur if the tool is tipped or if the cutting tool is unintentionally contacted.
19. **CHECK DAMAGED PARTS.** Before further use of the tool, a guard or other part that is damaged should be carefully checked to determine that it will operate properly and perform its intended function – check for alignment of moving parts, binding of moving parts, breakage of parts, mounting, and any other conditions that may affect its operation. A guard or other part that is damaged should be properly repaired or replaced.
20. **DIRECTION OF FEED.** Feed work into a blade or cutter against the direction of rotation of the blade or cutter only.
21. **NEVER LEAVE TOOL RUNNING UNATTENDED. TURN POWER OFF.** Don't leave tool until it comes to a complete stop.

Grounding Instructions



WARNING: All electrical connections must be performed by a qualified electrician.

POWER SOURCE

The motor is designed for operation on the voltage and frequency specified. Normal loads will be handled safely on voltages not more than 10% above or below the specified voltage.

Running the unit on voltages which are not within the range may cause overheating and motor burnout. Heavy loads require that voltage at motor terminals be no less than the voltage specified on nameplate. Power supply to the motor is controlled by a single pole locking rocker switch. Remove the key to prevent unauthorized use.

GROUNDING INSTRUCTIONS

WARNING: Improper connection of equipment grounding conductor can result in the risk of electrical shock. Equipment should be grounded while in use to protect operator from electrical shock.

- Check with a qualified electrician if grounding instructions are not understood or if in doubt as to whether the tool is properly grounded.
- This tool is equipped with an approved 3-conductor cord rated at 300V and a 3-prong grounding type plug for your protection against shock hazards.
- Grounding plug should be plugged directly into a properly installed and grounded 3-prong grounding-type receptacle, as shown.

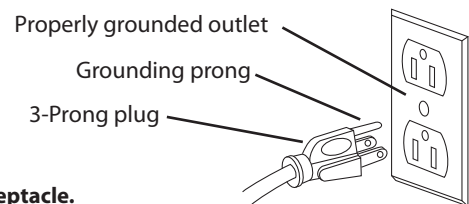

3-Prong receptacle.

- Do not remove or alter grounding prong in any manner. In the event of a malfunction or breakdown, grounding provides a path of least resistance for electrical shock.

WARNING: Do not permit fingers to touch the terminals of plug when installing or removing from outlet.

- Plug must be plugged into matching outlet that is properly installed and grounded in accordance with all local codes and ordinances. Do not modify plug provided. If it will not fit in outlet, have proper outlet installed by a qualified electrician.
- Inspect tool cords periodically, and if damaged, have repaired by an authorized service facility.
- Green (or green and yellow) conductor in cord is the grounding wire. If repair or replacement of the electric cord or plug is necessary, do not connect the green (or green and yellow) wire to a live terminal.
- Where a 2-prong wall receptacle is encountered, it must be replaced with a properly grounded 3-prong receptacle installed in accordance with National Electric Code and local codes and ordinances.

WARNING: This work should be performed by a qualified electrician.

Grounding Instructions (continued)

- A temporary 3-prong to 2-prong grounding adapter is available for connecting plugs to a two pole outlet if it is properly grounded.

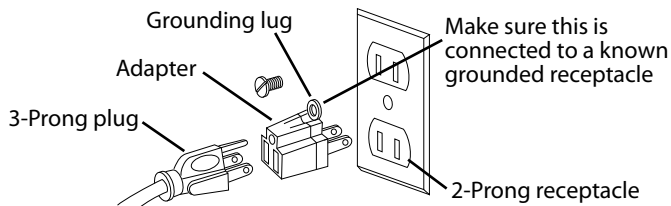

2-Prong receptacle with adapter.

- Do not use a 3-prong to 2-prong grounding adapter unless permitted by local and national codes and ordinances. (A 3-prong to 2-prong grounding adapter is not permitted in Canada.) Where permitted, the rigid green tab or terminal on the side of the adapter must be securely connected to a permanent electrical ground such as a properly grounded water pipe, a properly grounded outlet box or a properly grounded wire system.
- Many cover plate screws, water pipes and outlet boxes are not properly grounded. To ensure proper ground, grounding means must be tested by a qualified electrician.

EXTENSION CORDS

Use proper extension cord. Make sure your extension cord is in good condition. When using an extension cord, be sure to use one heavy enough to carry the current your product will draw. An undersized cord will cause a drop in line voltage resulting in loss of power and overheating. Table shows the correct size to use

depending on cord length and nameplate ampere rating. If in doubt, use the next heavier gage. The smaller the gage number, the heavier the cord.

Extension Cord Table						
		Volts	Total Length of Cord in Feet			
Ampere Rating		115	25	50	100	150
More Than	Not More Than	230	50	100	150	300
		Minimum Gage for Cord				
0	6		18	16	16	14
6	10		18	16	14	12
10	12		16	16	14	12
12	16		14	12	Not Recommended	

ELECTRICAL CONNECTIONS

WARNING: All electrical connections must be performed by a qualified electrician. Make sure tool is off and disconnected from power source while motor is mounted, connected, reconnected or anytime wiring is inspected.

- Motor and wires are installed as shown in wiring diagram. Motor is assembled with approved, 3-conductor cord to be used at 115/230 volts. Motor is prewired at the factory for 115 volts.

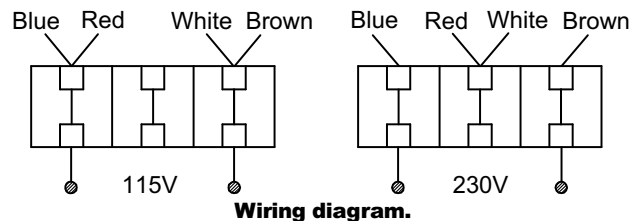

Wiring diagram.

- To use the sander with a 230V power supply, have a qualified electrician rewire motor and attach a 230 volt, 15A three-prong plug onto drill press line cord.

Drill Press Safety Warnings

For Your Own Safety Read Instruction Manual Before Operating Drill Press

1. Wear eye protection.
2. Do not wear gloves, necktie, or loose clothing.
3. Clamp workpiece or brace against column to prevent rotation.
4. Use recommended speed for drill accessory and workpiece material.
5. The included chuck key is specially designed to be self-ejecting, reducing the risk of ejecting at high speed. Only use the included chuck key or an identical replacement key.
6. **DO NOT OPERATE WITH ANY GUARD DISABLED, DAMAGED, OR REMOVED. Moving guards must move freely and close instantly.**
7. The use of accessories or attachments not recommended by the manufacturer may result in a risk of injury to persons.
8. When servicing use only identical replacement parts.
9. Only use safety equipment that has been approved by an appropriate standards agency. Unapproved safety equipment may not provide adequate protection. Eye protection must be ANSI-approved and breathing protection must be NIOSH-approved for the specific hazards in the work area.
10. Stay alert, watch what you are doing and use common sense when operating a power tool. Do not use a power tool while you are tired or under the influence of drugs, alcohol or medication. A moment of inattention while operating power tools may result in serious personal injury.
11. Industrial applications must follow OSHA guidelines.
12. Maintain labels and nameplates on the tool. These carry important safety information. If unreadable or missing, contact Harbor Freight Tools for a replacement.
13. Avoid unintentional starting. Prepare to begin work before turning on the tool.
14. People with pacemakers should consult their physician(s) before use. Electromagnetic fields in close proximity to heart pacemaker could cause pacemaker interference or pacemaker failure.
15. The warnings, precautions, and instructions discussed in this instruction manual cannot cover all possible conditions and situations that may occur. It must be understood by the operator that common sense and caution are factors which cannot be built into this product, but must be supplied by the operator.

Vibration Safety

This tool vibrates during use. Repeated or long-term exposure to vibration may cause temporary or permanent physical injury, particularly to the hands, arms and shoulders.

To reduce the risk of vibration-related injury:

1. Anyone using vibrating tools regularly or for an extended period should first be examined by a doctor and then have regular medical check-ups to ensure medical problems are not being caused or worsened from use. Pregnant women or people who have impaired blood circulation to the hand, past hand injuries, nervous system disorders, diabetes, or Raynaud's Disease should not use this tool. If you feel any medical or physical symptoms related to vibration (such as tingling, numbness, and white or blue fingers), seek medical advice as soon as possible.
2. Do not smoke during use. Nicotine reduces the blood supply to the hands and fingers, increasing the risk of vibration-related injury.
3. Use tools with the lowest vibration when there is a choice between different processes.
4. Include vibration-free periods each day of work.
5. Grip workpiece as lightly as possible (while still keeping safe control of it). Let the tool do the work.
6. To reduce vibration, maintain the tool as explained in this manual. If any abnormal vibration occurs, stop use immediately.

CAUTION! Use of controls or adjustments or performance of procedures other than those specified herein may result in hazardous exposure.

CAUTION! The use of optical instruments with this product will increase eye hazard.



SAVE THESE INSTRUCTIONS.

SPECIFICATIONS

Item # 9680117

Swing	17"	Table Work Surface	13 x 13"
Motor HP	1-1/5 HP	Table XYZ dimensions	13.2" x 13.2" x 3.94"
Volts/Phase	115/230V, 1.2HP	Table Slots	Ø0.6" x 4.5"
Amps/AC	8/4	Overall Dimensions	27.7" x 15" x 65"
Max drill capacity in iron and aluminum	Max. 16mm.	Quill diameter	2.05"
Spindle Speeds	Variable	Quill collar diameter	2.95"
RPM	230 - 3,100 RPM	Column diameter	3.15"
Spindle Taper	MT3	Base mounting hole sizes, Location	Ø0.472"; 15.75" x 8.66"
Spindle Travel	4.7"	Base T-slot	Ø0.59" x 7.09"
Spindle to Table	42.3"	Weight	"N.W.: 180lbsG.W: 193lbs"

SETUP - BEFORE USE



Read the **ENTIRE IMPORTANT SAFETY INFORMATION** section at the beginning of this manual including all text under subheadings therein before set up or use of this product.

WARNING

TO PREVENT SERIOUS INJURY FROM ACCIDENTAL OPERATION:

Turn the Power Switch of the tool off and unplug the tool from its electrical outlet before performing any procedure in this section.

Note: For additional information regarding the parts listed in the following pages, refer to the Assembly Diagram near the end of this manual.

Mounting

CAUTION! Secure Drill Press to a supporting structure before use.

1. Verify that installation surface has no hidden utility lines before drilling or driving screws.
2. Bolt Base to a flat, level, solid floor location capable of supporting the weight of the Drill Press and any work pieces.

Assembly

Column to Base

1. Place Column Base (141) onto the Base (136).
2. Place Bolts (142) in Column Base and Base.
3. Tighten Bolts.

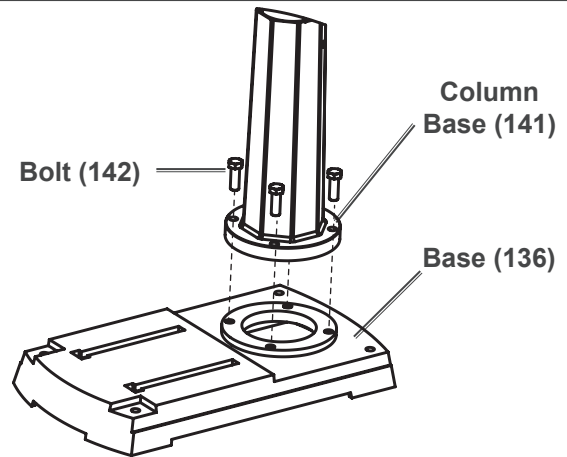
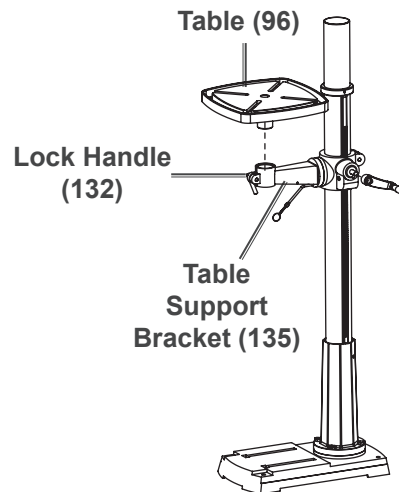

Table to Table Support

1. Thread Lock Handle (132) into Table Support Bracket (135).
2. Lower Table (96) into Table Support Bracket and tighten Lock Handle to secure.



Headstock to Column

Note: Make sure Set Screw (98) is backed out enough to allow column insertion.

1. With help of an assistant, lift Headstock (57) above Column (124), and gently slide it down Column as far as it will go.

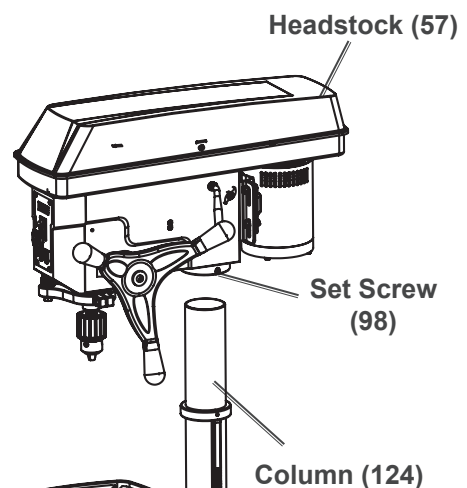

2. Align Headstock with Base (136).
3. Using a hex wrench, tighten Set Screw (98) to secure Headstock in place.

Installing Speed Handle

1. Install Speed Handle (92) by threading into opening on left side of Drill Press.

Speed Handle (92)

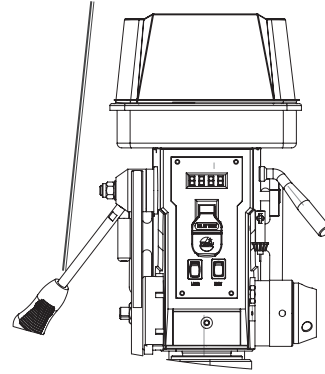

Feed Handles/Bars

Thread Feed Bars (67) into Feed Bar Seat (68) and tighten them.

Feed Bar
Seat (68)

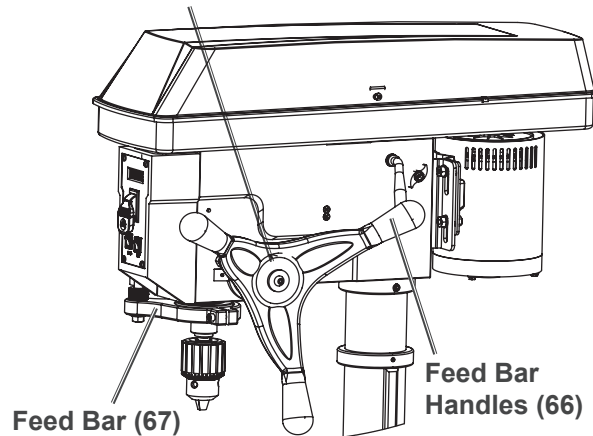

Installing/Removing the Chuck

1. Thoroughly clean Arbor (120) and the tapered hole in Chuck (121) of all dirt, grease, oil, and protective coatings. Make sure all parts are thoroughly clean, dry and burr free.
2. Insert Arbor into end of Spindle (119). If necessary, rotate Arbor to ensure that it is correctly positioned and fully inserted into the Spindle shaft. Firmly tap Arbor nose with a rubber mallet.
3. Open jaws of the Chuck to their maximum, using the supplied Chuck Key.
4. Slide the Chuck onto the Arbor nose as far as it will go.
5. Hold a piece of scrap wood against the Chuck nose to protect it and firmly tap wood with a rubber mallet to ensure proper seating and a solid fit of the Chuck on the Spindle.
6. To remove Chuck, use Feed Handles to lower Chuck until slots in Quill and Spindle are exposed. Rotate chuck until they align.
7. Adjust lower Stop Nut all the way up to lock Spindle in place.
8. Insert Drift Key (97) into slot and tap it with a rubber mallet (not included) to release Chuck and Arbor. **Make sure to hold Chuck with one hand to prevent it from falling.**

OPERATING INSTRUCTIONS



Read the **ENTIRE IMPORTANT SAFETY INFORMATION** section at the beginning of this manual including all text under subheadings therein before set up or use of this product.

SAFETY

Tool Set Up

⚠️WARNING

TO PREVENT SERIOUS INJURY FROM ACCIDENTAL OPERATION:

Turn the Power Switch of the tool off and unplug the tool from its electrical outlet before performing any procedure in this section.

TO PREVENT SERIOUS INJURY:

DO NOT OPERATE WITH ANY GUARD DISABLED, DAMAGED, OR REMOVED.

Moving guards must move freely and close instantly.

Table Adjustment

SETUP

1. Raise or lower Table by loosening Lock Handle (140) and turning Height Crank (127) clockwise to raise and counterclockwise to lower.

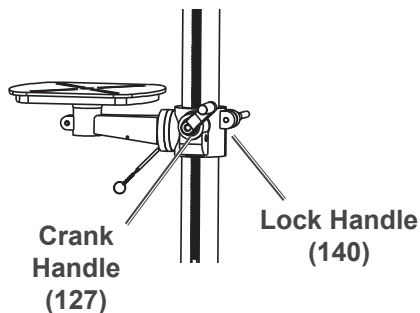

2. Loosen Lock Handle to pivot Table (96) around Column.

3. Remove Locating Pin (79).
4. Loosen Adjustment Bolt and tilt to required angle.
5. Tighten Adjustment Bolt.
6. To adjust table back to horizontal, loosen Adjustment Bolt, tilt table to 0°, and insert Locating Pin.

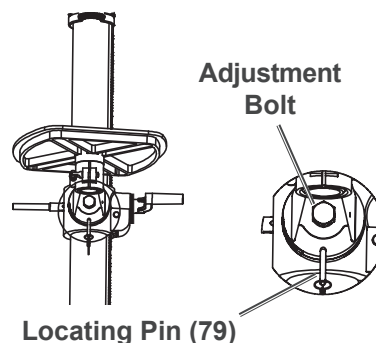

OPERATION

7. TO ENSURE THAT THE DRILL IS ENTIRELY PERPENDICULAR TO THE TABLE, insert a straight round bar (not included) into Chuck, place a square on Table and bring it up to round bar. Adjust angle as needed.

CAUTION! To prevent injury from unexpected Table movement, tighten Lock Handle (140) after adjustment.

MAINTENANCE

Setting a Drilling Depth

Pushing button on Depth Scale Knob allows for depth adjustments on the Depth Scale.

1. Push button on Depth Scale Knob and slide Knob until bottom of Knob is aligned with desired depth mark on Gauge Scale. Release button.
2. Rotate Depth Scale Knob for fine-tuning of the setting.

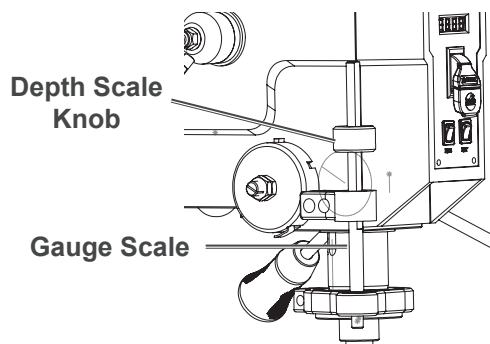

Changing Drill Speed

1. Refer to table below to determine appropriate speed for drill size being used.
2. To adjust drill speed, simply raise or lower the Speed Handle (91) until LED display shows desired RPM.

Note: Drill press must be running during speed change.

Note: If Belt is too long to be properly tensioned, it must be replaced.

Speed Range (RPM)	WOOD Drill Bit Size		ALUMINUM/ZINC/BRASS Drill Bit Size		IRON/STEEL Drill Bit Size	
	IN	mm	IN	mm	IN	MM
2000 - 3100	3/8	9.5	7/32	5.6	3/32	2.4
1400 - 2000	5/8	16	11/32	8.75	5/32	4
1000 - 1400	7/8	22	15/32	12	1/4	6.4
800 - 1000	1-1/4	31.75	11/16	17.5	3/8	9.5
230 - 800	1-5/8	41.4	3/4	19	1/2	12.5

The table above shows drill speeds for various materials used by this Press.

Drill Bit Installation

1. Insert drill bit into jaws of Chuck approximately 1", ensuring that jaws do not touch flutes of drill bit.
2. Before tightening Chuck, ensure that drill bit is centered within jaws.
3. Tighten Chuck securely with included Chuck Key.

Workpiece and Work Area Set Up

SAFETY

1. Designate a work area that is clean and well-lit. The work area must not allow access by children or pets to prevent distraction and injury.
2. Route the power cord along a safe route to reach the work area without creating a tripping hazard or exposing the power cord to possible damage. The power cord must reach the work area with enough extra length to allow free movement while working.
3. Secure loose workpieces using a vise or clamps (not included) to prevent movement while working.
4. There must not be objects, such as utility lines, nearby that will present a hazard while working.

SETUP

5. Make sure the table height and position is set so that the drill travel range is sufficient for the material to be drilled.
6. Make sure the work is securely clamped. That is, held in a drill vise, or bolted to the table. Never hold the material with your bare hands while drilling. Severe personal injury may be caused if the material is flung out of the operator's hand.

OPERATION

MAINTENANCE

7. IF THE MATERIAL IS IRREGULARLY SHAPED and cannot be laid flat on the table, it should be securely blocked and clamped. Any tilting, twisting or shifting will result not only in a roughly drilled hole but also increases the chances of damage to the drill.
8. FOR FLAT WORK, lay the piece on to a wooden base and clamp it down firmly against the table to prevent it from turning.
9. FOR SMALL MATERIALS that cannot be clamped to the table, use a drill press vise. Make sure the vise is clamped or bolted to the table.
10. WHEN DRILLING COMPLETELY THROUGH WOOD, position a piece of scrap wood between the material and the table to prevent splintering on the underside of the material as the drill breaks through. The scrap piece of wood must make contact with the left side of the column. Securely clamp the other end of the scrap wood to the table. Also, set the depth of the drill so that the drill will not come in contact with the table - or align the table so that the hole in its center is in line with the drill bit.

General Operating Instructions

1. Bring drill bit down with Feed Knob to where hole is to be drilled.
Make minor workpiece alignment adjustments.
2. Plug Power Cord into an electrical outlet.
3. Turn Drill Press on.
4. Move speed lever to appropriate setting (see table on page 9).
5. Pull down on the Feed Knob and slowly drill hole into workpiece.
6. Turn Drill Press off by flipping Power Switch down.

7. To lock Drill Press in OFF position, remove safety key from Power Switch and store key in a safe place until next use.

WARNING! TO PREVENT SERIOUS INJURY: If the drill bit grabs and spins the workpiece, do not attempt to stop the spinning with your hands. Step back, and turn the drill press off. Wait for the spindle to stop turning before dislodging the workpiece.

8. To prevent accidents, turn off tool and disconnect its power supply after use. Clean, then store tool indoors out of children's reach.

Laser Function

WARNING! TO PREVENT SERIOUS INJURY: Do not stare directly into laser beam. Please observe all safety rules:

- a. Never aim the beam at a person or an object other than the workpiece.
- b. Do not project the laser beam into the eye of others.

c. Always make sure the laser beam is aimed at a workpiece that does not possess reflective surfaces, as the laser beam could project into your eyes or the eyes of others.

1. Place workpiece on table.
2. Turn Laser Switch to ON.

Note: The two laser lines cross where drill meets workpiece.

3. Lower Drill to meet Workpiece.

MAINTENANCE AND SERVICING



Procedures not specifically explained in this manual must be performed only by a qualified technician.

⚠️ WARNING

TO PREVENT SERIOUS INJURY FROM ACCIDENTAL OPERATION:

Turn the Power Switch of the tool off and unplug the tool from its electrical outlet before performing any procedure in this section.

TO PREVENT SERIOUS INJURY FROM TOOL FAILURE:

Do not use damaged equipment. If abnormal noise or vibration occurs, have the problem corrected before further use.

Cleaning, Maintenance, and Lubrication

1. **BEFORE EACH USE**, inspect the general condition of the tool. Check for:
 - loose hardware
 - misalignment or binding of moving parts
 - cracked or broken parts
 - damaged electrical wiring
 - any other condition that may affect its safe operation.
2. **AFTER USE**, wipe external surfaces of the tool with clean cloth.
3. **⚠️ WARNING! TO PREVENT SERIOUS INJURY:** If the supply cord of this power tool is damaged, it must be replaced only by a qualified service technician.
4. Periodically wear ANSI-approved safety goggles and NIOSH-approved breathing protection and blow dust out of the motor vents using dry compressed air.
5. Periodically apply a light coat of machine oil to the column to inhibit rust.
6. Apply a light coat of paste wax, or similar product, to the table surface to protect the metal and inhibit rust. (Avoid products containing silicone, which may stain wood.)

Belt Inspection and Tensioning

1. Examine belt for cracks, tears in backing, and other damage.
2. Replace belt if damaged.
3. Loosen Lock Handle.

Note: Belt should deflect to 1/2" while pressing midway between pulleys. Do not overtighten belt.
4. Turn Belt Tension Handle clockwise to desired tension and hold.
5. Tighten Lock Handle.

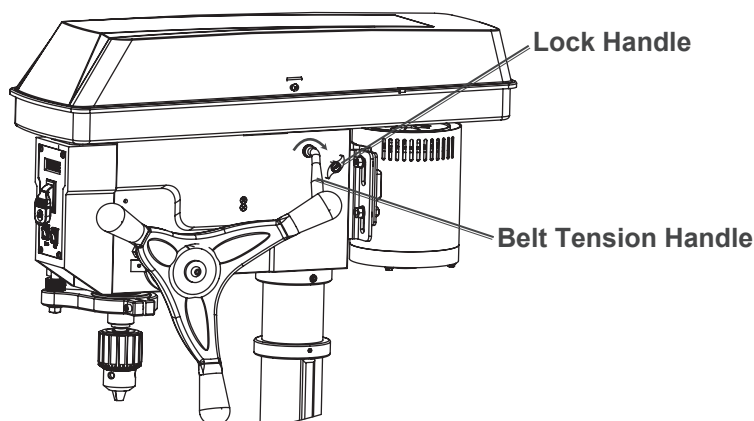

Laser Adjustment

WARNING! TO PREVENT SERIOUS

INJURY: Do not stare directly into laser beam. Please observe all safety rules:

- a. Never aim the beam at a person or an object other than the workpiece.
 - b. Do not project the laser beam into the eye of others.
 - c. Do not use a workpiece with reflective surfaces, as the laser beam could project into your eyes or the eyes of others.
1. Adjust table to 0° and clamp a workpiece to table.
 2. Use a small drill bit in the chuck, and lower it to create an indentation in workpiece.
 3. Turn on Laser Switch. Lasers should intersect exactly at the indentation.
 4. If laser needs adjustment, use a 3mm hex key (not included) to turn Laser Adjustment Set Screws counterclockwise.

5. Gently rotate Laser Housing until both Laser lines intersect at the indentation.
6. Tighten both set screws.

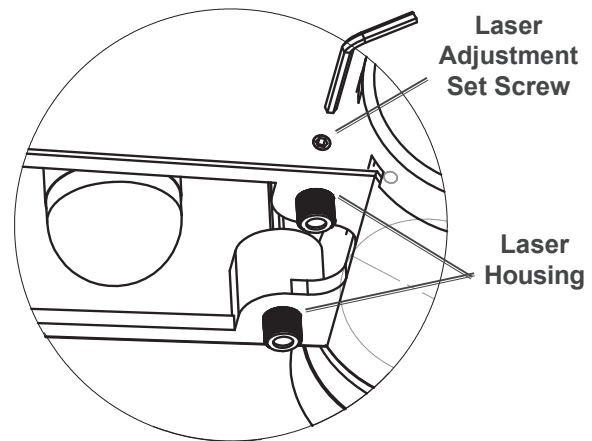

Troubleshooting

Problem	Possible Causes	Likely Solutions
Tool will not start.	<ol style="list-style-type: none"> 1. Cord not connected. 2. No power at outlet. 3. Tool's thermal reset breaker tripped (if equipped). 4. Internal damage or wear. (Carbon brushes or switch, for example.) 	<ol style="list-style-type: none"> 1. Check that cord is plugged in. 2. Check power at outlet. If outlet is unpowered, turn off tool and check circuit breaker. If breaker is tripped, make sure circuit is right capacity for tool and circuit has no other loads. 3. Turn off tool and allow to cool. Press reset button on tool. 4. Have technician service tool.
Tool operates slowly.	Extension cord too long or wire size too small.	Eliminate use of extension cord. If an extension cord is needed, use one with the proper diameter for its length and load. See Table A on page 2.
Performance decreases over time.	<ol style="list-style-type: none"> 1. Accessory dull or damaged. 2. Carbon brushes worn or damaged. 	<ol style="list-style-type: none"> 1. Keep cutting accessories sharp. Replace as needed. 2. Have qualified technician replace brushes.
Excessive noise or rattling.	<ol style="list-style-type: none"> 1. Internal damage or wear. (Carbon brushes or bearings, for example.) 2. Belt (if equipped) too loose (slipping) or too tight (bearing damage). 	<ol style="list-style-type: none"> 1. Have technician service tool. 2. Properly tension belt.
Overheating.	<ol style="list-style-type: none"> 1. Forcing machine to work too fast. 2. Accessory dull or damaged. 3. Blocked motor housing vents. 4. Motor being strained by long or small diameter extension cord. 	<ol style="list-style-type: none"> 1. Allow machine to work at its own rate. 2. Keep cutting accessories sharp. Replace as needed. 3. Wear ANSI-approved safety goggles and NIOSH-approved dust mask/respirator while blowing dust out of motor using compressed air. 4. Eliminate use of extension cord. If an extension cord is needed, use one with the proper diameter for its length and load. See Table A on page 2.



Follow all safety precautions whenever diagnosing or servicing the tool. Disconnect power supply before service.

PARTS ILLUSTRATION FOR 9680117 17" VARIABLE-SPEED DRILL PRESS

SAFETY

SETUP

OPERATION

MAINTENANCE

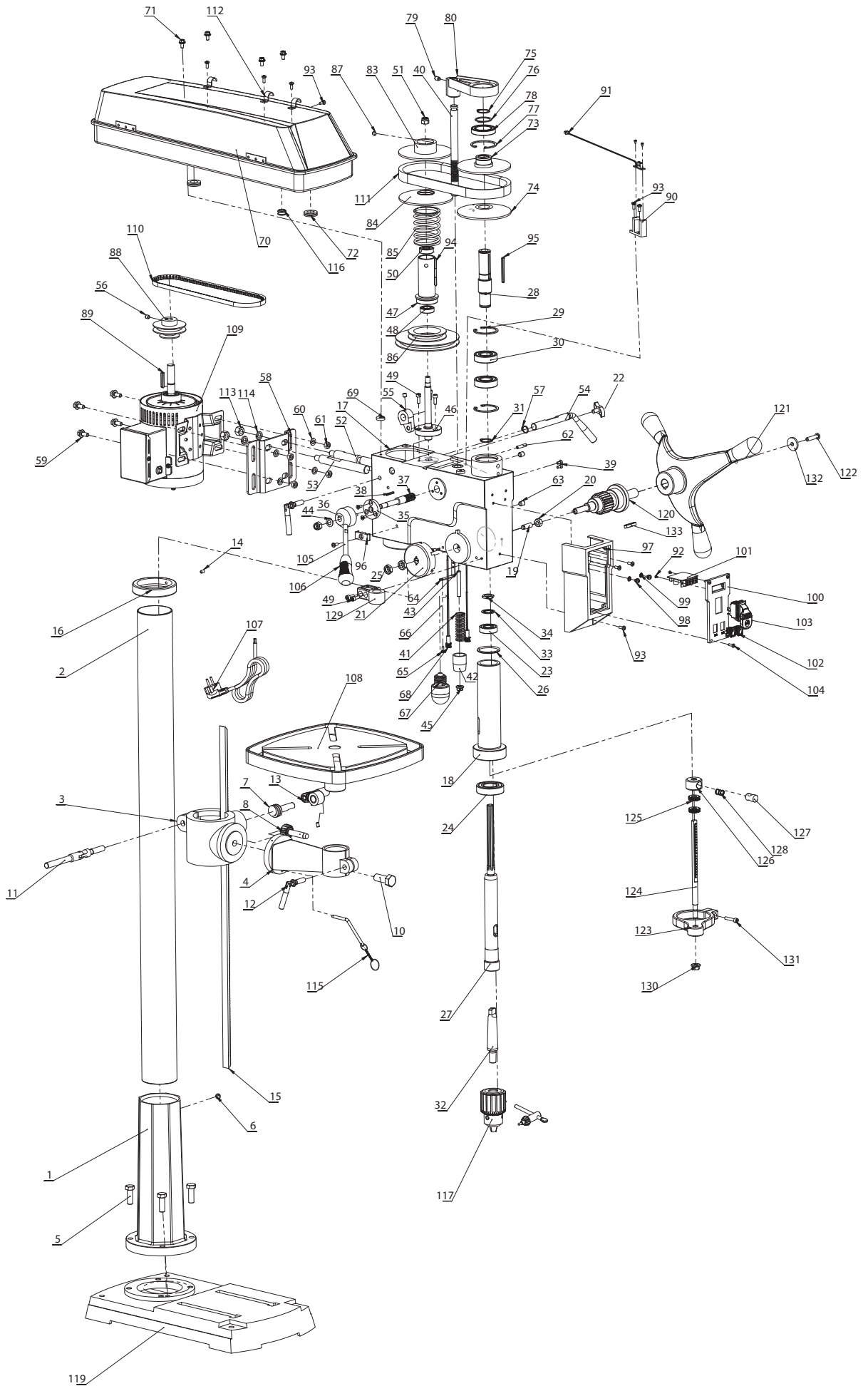

PARTS LIST FOR 9680117 17" VARIABLE-SPEED DRILL PRESS

Ref. No.	Description	Part No.	Qty.	Ref. No.	Description	Part No.	Qty.
1	Column Seat	965276301	1	68	Laser	965280201	2
2	Column	965276401	1	69	Sponge Pad	965280301	4
3	Table Bracket	965276501	1	70	Belt Pulley Cover Assembly	965280401	1
4	Table Support Arm	965276601	1	71	Hex Head Flange Screw, M6x12	*	4
5	Hex Head Bolt, M12x35	*	4	72	Rubber Grommet	965280501	2
6	Set Screw, M10x10	*	1	73	Wheel On Spindle	965280601	1
7	Worm Gear	965276701	1	74	Main Shaft Lower Wheel	965280701	1
8	Pinion Gear & Shaft	965276801	1	75	External Circlips-M26	*	1
10	Hex Head Bolt, M16x40	*	1	76	External Circlips M35	*	1
11	Table Bracket Locking Handle	965276901	1	77	Elastic Retaining Ring For Holes M55	*	1
12	Table Support Locking Handle	965277001	2	78	Deep Groove Ball Bearing, 61907-2rz	*	1
13	Table Crank Handle	965277101	1	79	Set Screw, Cone Point, M8x12	*	1
14	Set Screw, M10x10	*	4	80	Adjustment Seat	965280801	1
15	Rack	965277201	1	81	Counter Blocking Plate	965280901	1
16	Rack Retaining Ring	965277301	1	82	Philips Head Screw, M4x7	*	1
17	Head Casting	N/A	1	83	Intermediate Wheel Upper Wheel	965281001	1
18	Quill	965277401	1	84	Intermediate Wheel Lower Wheel	965281101	1
19	Quill Positioning Screw	965277501	1	85	Intermediate Wheel Compression Spring	965281201	1
20	Hex Nut, M10	*	1	86	Intermediate Wheel Triangular Belt Wheel	965281301	1
21	Spring Cap Assembly	965277601	1	87	Set Screw, Cone Point, M8x10	*	1
22	Plastic Knob	965277701	1	88	Motor V-Belt Pulley	965281401	1
23	Deep Groove Ball Bearing, 6203-2RZ	*	1	89	Hex Shaft Key-C, 5x5x35	*	1
24	Deep Groove Ball Bearing, 6206-2RZ/C3	*	1	90	Counter Seat Bracket	965281501	1
25	Hex Nut	965277801	2	91	Photoelectric Counter	965281601	1
26	O-Ring Rubber Seal, M52xM3.5	965277901	1	92	Phillips Head Self Tapping Screw, St2.9x6.5	*	4
27	Lower Spindle	965278001	1	93	Phillips Screw, M5x12	*	10
28	Upper Spindle	965278101	1	94	A-Type Slotted Flat Key, 4x4x60	965281701	1
29	Retaining Ring , M52	*	2	95	Flat Key, 4x4x60	965281801	1
30	Deep Groove Ball Bearing, 6205-2RZ	*	2	96	Cord Clamp	965281901	1
31	External Circlips, M25	*	1	97	Switch Box	965282001	1
32	Arbor MT3/JT3	965278201	1	98	Phillips Screw & Washer, M5x8	*	2
33	Internal Tooth Locking Washer, M18	965278301	1	99	External Teeth Lock Washer, M5	*	2
34	Hex Thin Nut	965278401	1	100	Switch Box Cover	965282101	1
35	Gear Seat	965278501	1	101	Digital Readout	965282201	1
36	Speed Control Handle Seat	965278601	1	102a	Laser Power Switch, HY17-2P	965282301	1
37	Gear Shaft	965278701	1	102b	Light Power Switch, HY17-2P	965282301	1
38	Hex Shaft Key, 3x3x25	*	1	103	Locking Paddle Switch, HY18-2P	965282401	1
39	Phillips Head Screw, M5x12	*	5	104	Phillips Self Tapping Screw, ST4.2x16	*	4
40	Rack Shaft	965278801	1	105	Speed Control Lever	965282501	1
41	Rack Compression Spring	965278901	1	106	Speed Control Handle Cover	965282601	1
42	Rack Adjustment Sleeve	965279001	1	107	Power Cord with Plug	965282701	1
43	Set Screw, M8x6	*	1	108	Work Table	965282801	1
44	Butterfly Spring Washer	965279101	1	109	Motor, 1.2 HP	965282901	1
45	Hex Flange Nut, M8	*	1	110	Cogged V-Belt, M29.5	965283001	1
46	Intermediate Wheel Shaft	965279201	1	111	Industrial Wide V-Belt	965283101	1
47	Intermediate Wheel Sleeve	965279301	1	112	Wire Clamps	965283201	3
48	Deep Groove Ball Bearing, 6002-2RZ	*	1	113	Hex Nut, M12	*	2
49	Hex Socket Head Screw, M6x16	*	5	114	Spring Washer, M12	*	2
50	Deep Groove Ball Bearing, 6201-2RZ	*	1	115	Positioning Pin	965283301	1
51	Nylock Hex Nut, M10	*	2	116	Rubber Grommet	965283401	1
52	Motor Support Rod 1	965279401	1	117	Chuck & Key, 5/8" JT3	965283501	1
53	Motor Support Rod 2	965279501	1	119	Base	965283601	1
54	Motor Tension Lever	965279601	1	120	Quill Feed Assembly	965283701	1
55	Cam Bracket	965279701	1	121	Quill Feed Handle	965283801	1
56	Set Screw, M8x8	*	2	122	Socket Head Screw, M8x16	*	1
57	External Circlips, M15	*	1	123	Depth Scale Quill Bracket	965283901	1
58	Motor Mount Plate	965279801	1	124	Depth Scale	965284001	1
59	Hex Flange Bolt, M8x16	*	4	125	Scaleadjusting Nut	965284101	2
60	Flat Washer , M8	*	4	126	Depth Scale Sleeve	965284201	1
61	Hex Nut, M8	*	4	127	Limit Block	965284301	1
62	Spring Pin, 6x30	*	2	128	Scale Compression Spring	965284401	1
63	Set Screw, M10x12	*	2	129	Depth Scale Fixed Seat	965284501	1
64	Lamp Socket Support Bracket	965279901	1	130	Hex Flange Nuts, M10	*	1
65	Phillips Screw, M4x10	*	1	131	Socket Head Screw, M6x25	*	1
66	Lamp Socket	965280001	1	132	Locking Gasket for Quill Feed Handle	965284601	1
67	Led Lamp	965280101	1	133	Hex Shaft Key-C, 6x6x35	*	1

(Δ) Not shown. (N/A) Not available as repair part. (*) Standard hardware item, available locally.

PALMGREN WARRANTY

C.H. Hanson / Palmgren warrants their products to be free of defects in material or workmanship. This warranty does not cover defects due directly or indirectly to misuse, abuse, normal wear and tear, failure to properly maintain the product, heated, ground or otherwise altered, or used for a purpose other than that for which it was intended.

The warranty does not cover expendable and/or wear part (i.e. v-belts, screws, abrasives, jaws), damage to tools arising from alteration, abuse or use other than their intended purpose, packing and freight. The duration of this warranty is expressly limited to the terms noted below beginning from the date of delivery to the original user.

The Palmgren branded items carry the following warranties on parts:

All arbor presses, vises, clamps, positioning tables, tombstones, jack screws and vise accessories - LIFETIME.

All bench grinders, drill presses, tapping machines, band saws, lathes, milling machines, abrasive finishing machines and work stands - 3 YEARS.

The obligation of C.H. Hanson / Palmgren is limited solely to the repair or replacement, at our option, at its factory or authorized repair agent of any part that should prove inoperable. Purchaser must lubricate and maintain the product under normal operating conditions at all times. Prior to operation become familiar with product and the included materials, i.e. warnings, cautions and manuals.

Failure to follow these instructions will void the warranty.

This warranty is the purchaser's exclusive remedy against C.H. Hanson for any inoperable parts in its product. Under no circumstances is C.H. Hanson liable for any direct, indirect, incidental, special or consequential damages including loss of profits in any way related to the use or inability to use our products. This warranty gives you specific legal rights which may vary from state to state.

PALMGREN®

Palmgren - a C.H. Hanson Company
2000 N. Aurora Rd., Naperville, IL 60563 U.S.A.
or call 1-800-827-3398