

# Technical Specifications



CERTIFIED TO CAN/CSA C22.2 No. 60335-2-40:22 /  
UL 60335-2-40, CSA/ANSI Z21.47, CAN/CSA 2.3,  
AND CAN/CGA STD. 2:17



## P-S SERIES 11.7SEER2

### Non-Condensing Gas Heat / Electric Cooling

Self contained, Standard efficiency Thru-The-Wall heating & cooling unit 80% AFUE

Input 26 000 - 64 000 BTU/h

## FEATURES



### COMPATIBLE BOX SIZE

- Industry standard footprint for retrofit applications.
- Appliance shell dimensions: 43 1/8" High x 28" Wide x 32" Deep.
- Wall Sleeve dimensions where penetrating exterior wall: 44 7/8" High x 28 7/8" Wide.
- Standard TAUPE color.

### HEATING FEATURES

- Up to 80 % AFUE Single Stage Gas Module.
- Stainless steel heat exchanger.
- Sealed Vestibule – keeps cold external air from circulating in dwelling

### CIRCULATION BLOWER

- Dual Inlet Blower for higher flow rates / reduced air noise.
- Multi-Speed Electronically Commutated Motor for increased electrical efficiency.
- Supplied with standard size 16"x25"x1" MERV8 non-washable pleated air filter.

### COOLING FEATURES

- Minimum 11.7SEER2 Efficiency.
- All models are installed with TXV, which ensures optimized efficiency.
- Micro-Channel Condenser and Evaporator Coils.
- R-454B Refrigerant System.
- High Efficiency compressors for all AC modules.
- B30A uses Two Stage compressor\*.

### SERVICE ADVANTAGES

- Indoor access to all parts & maintenance needs.
- Innovative, dual slide-out chassis can be partially or fully removed for efficient servicing ("**BXXA**" cooling chassis only be swapped in "**BXXA**" cooling cabinets)
- With spare modules, building management can perform quick swap outs, maintaining indoor conditions in the apartment/condo, while troubleshooting non functioning units off line.
- Can perform direct replacement of the individual modules at the end of their service life instead of replacement of the complete appliance.
- All control harnesses are separated with modular quick disconnects so module swap outs do not require time consuming rewiring.

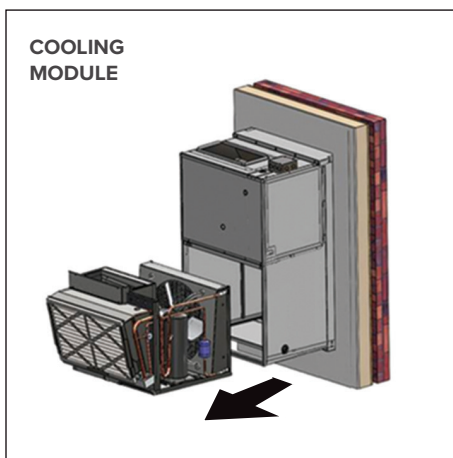
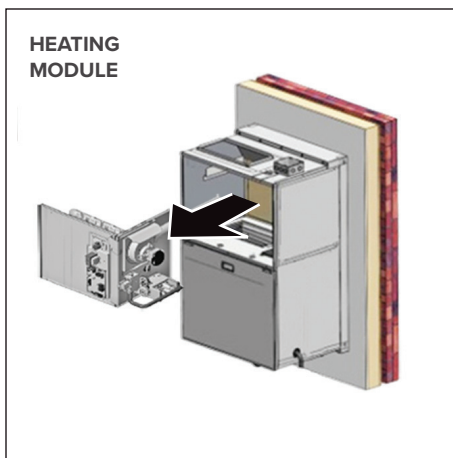

\*Note: To take full advantage of Two stage cooling for B30A module, a 2 stage thermostat is recommended.

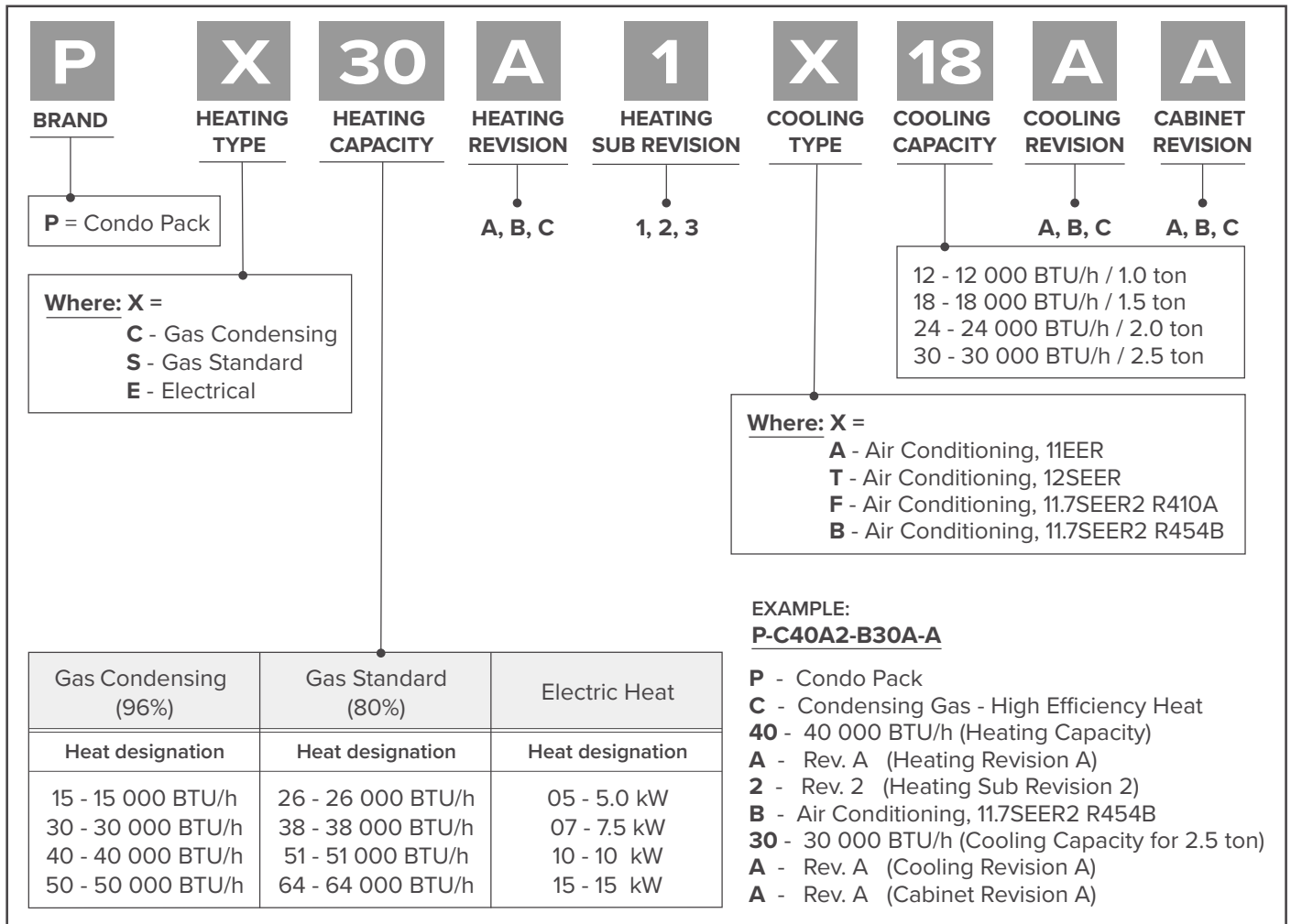

## PERFORMANCE

**TABLE 1.**

| HEATING             | P-S26A1-B12A-A | P-S26A1-B18A-A | P-S38A1-B12A-A | P-S38A1-B18A-A | P-S38A1-B24A-A |
|---------------------|----------------|----------------|----------------|----------------|----------------|
| AFUE                | 80%            |                |                |                |                |
| Input BTU/h         | 26,000         |                | 38,000         |                |                |
| Output BTU/h (AFUE) | 21,000         |                | 30,400         |                |                |
| COOLING             |                |                |                |                |                |
| BTU/h               | 12,300         | 17,000         | 12,300         | 17,000         | 21,200         |
| SEER2               | 11.7           |                |                |                |                |
| REF.                | R454B          |                |                |                |                |
| WEIGHT (LB)         | 328            | 349            | 328            | 349            |                |

| HEATING             | P-S51A1-B18A-A | P-S51A1-B24A-A | P-S51A2-B30A-A | P-S64B1-B18A-A | P-S64B1-B24A-A | P-S64B2-B30A-A |
|---------------------|----------------|----------------|----------------|----------------|----------------|----------------|
| AFUE                | 80%            |                |                |                |                |                |
| Input BTU/h         | 51,000         |                |                | 64,000         |                |                |
| Output BTU/h (AFUE) | 41,000         |                |                | 51,200         |                |                |
| COOLING             |                |                |                |                |                |                |
| BTU/h               | 17,000         | 21,200         | 26,400         | 17,000         | 21,200         | 26,400         |
| SEER2               | 11.7           |                |                |                |                |                |
| REF.                | R454B          |                |                |                |                |                |
| WEIGHT (LB)         | 349            |                | 366            | 349            |                | 366            |

## ELECTRICAL

**TABLE 2.**

| DESCRIPTION                            | 1.0 TON B12A      | 1.5 TON B18A     | 2.0 TON B24A     | 2.5 TON B30A    |
|--|-------------------|------------------|------------------|-----------------|
| Compressor Type                        | Rotary            |                  |                  | Scroll          |
| Compressor Rated Amps                  | 5.2               | 7.7              | 9.5              | 14.6            |
| Compressor LRA                         | 31.4              | 42.9             | 51.7             | 82              |
| MCA                                    | 11.3              | 14.9             | 17.1             | 23.6            |
| Max Fuse/Breaker (A)                   | 15                | 20               | 25               | 35              |
| Indoor Fan FLA/HP/RPM                  | 4.0/ 1/2 /1050    |                  |                  |                 |
| Condenser Fan FLA/HP/RPM               | 0.9/ 1/4 /1100    | 1.3/ 1/3 /1120** | 1.3/ 1/3 /1380** | 1.4 / 1/3 /1400 |
| Combustion Fan FLA                     | 1.25              |                  |                  |                 |
| Unit Input Voltage - Frequency - Phase | 208/230V-60Hz-1PH |                  |                  |                 |

| GAS CONTROLS AND ADDITIONAL DATA         |                     |         |
|--|---------------------|---------|
| IGNITION SYSTEM                          | SPARK IGNITION      |         |
| GAS CONNECTION                           | 1/2" NPT            |         |
| GAS & AC CONDENSATE HOSE SIZE (Supplied) | 1/2" ID and 5/8" ID | 5/8" ID |

\*\* 1.5 ton & 2.0 ton models have two speed condenser fan motors: Speed 1 is for 1.5 ton & Speed 2 is for 2.0 ton.

\* All specifications and designs can change without notice to allow for on-going improvements. Images may not be exactly as shown. Consult with your owner's manual for current information. Check all local and national building codes and gas regulations. Napoleon® is a registered trade mark of Wolf Steel Ltd.

**AIR FLOW**

**TABLE 3.**

| Model           | Heating/<br>Cooling | Actual Wire<br>Colour | Setting            | Speed<br>Tap # | SCFM at External Static Pressure (in.WC) |      |      |      |      |
|-----------------|---------------------|-----------------------|--------------------|----------------|--|------|------|------|------|
|                 |                     |                       |                    |                | 0.1"                                     | 0.2" | 0.3" | 0.4" | 0.5" |
| P-S26A1-B12A-A  | S26A1               | Red Wire              | Factory            | 5              | 372                                      | 314  | 261  | 214  | 188  |
|                 |                     |                       | High               | 4              | 497                                      | 454  | 405  | 360  | 313  |
|                 | G-Continuous Fan    | Black Wire            | -                  | 5              | 372                                      | 314  | 261  | 214  | 188  |
|                 | B12A                | Blue Wire             | Factory            | 1              | 485                                      | 449  | 410  | 376  | 341  |
| High            |                     |                       | 3                  | 614            | 584                                      | 551  | 521  | 490  |      |
| P-S26A1-B18A-A  | S26A1               | Red Wire              | Factory            | 5              | 372                                      | 314  | 261  | 214  | 188  |
|                 |                     |                       | High               | 4              | 497                                      | 454  | 405  | 360  | 313  |
|                 | G-Continuous Fan    | Black Wire            | -                  | 5              | 372                                      | 314  | 261  | 214  | 188  |
|                 | B18A                | Blue Wire             | Factory            | 4              | 670                                      | 641  | 610  | 580  | 551  |
| High            |                     |                       | 2                  | 707            | 680                                      | 651  | 621  | 592  |      |
| P-S38A1-B12A-A  | S38A1               | Red Wire              | Factory            | 4              | 497                                      | 454  | 405  | 360  | 313  |
|                 |                     |                       | High               | 3              | 712                                      | 679  | 652  | 620  | 583  |
|                 | G-Continuous Fan    | Black Wire            | -                  | 5              | 348                                      | 295  | 247  | 201  | 176  |
|                 | B12A                | Blue Wire             | Factory            | 1              | 485                                      | 449  | 410  | 376  | 341  |
| High            |                     |                       | 3                  | 614            | 584                                      | 551  | 521  | 490  |      |
| P-S38A1-B18A-A  | S38A1               | Red Wire              | Factory            | 4              | 497                                      | 454  | 405  | 360  | 313  |
|                 |                     |                       | High               | 3              | 712                                      | 679  | 652  | 620  | 583  |
|                 | G-Continuous Fan    | Black Wire            | -                  | 5              | 348                                      | 295  | 247  | 201  | 176  |
|                 | B18A                | Blue Wire             | Factory            | 1              | 670                                      | 641  | 610  | 580  | 551  |
| High            |                     |                       | 2                  | 707            | 680                                      | 651  | 621  | 592  |      |
| P-S38A1-B24A-A  | S38A1               | Red Wire              | Factory            | 4              | 497                                      | 454  | 405  | 360  | 313  |
|                 |                     |                       | High               | 3              | 712                                      | 679  | 652  | 620  | 583  |
|                 | G-Continuous Fan    | Black Wire            | -                  | 5              | 348                                      | 295  | 247  | 201  | 176  |
|                 | B24A                | Blue Wire             | Factory            | 1              | 831                                      | 806  | 780  | 754  | 728  |
| High            |                     |                       | (1&4)*             | 993            | 972                                      | 948  | 926  | 903  |      |
| P-S51A1-B18A-A  | S51A1               | Red Wire              | Factory            | 3              | 707                                      | 678  | 650  | 611  | 576  |
|                 |                     |                       | High               | 2              | 803                                      | 776  | 753  | 726  | 690  |
|                 | G-Continuous Fan    | Black Wire            | -                  | 5              | 348                                      | 295  | 247  | 201  | 176  |
|                 | B18A                | Blue Wire             | Factory            | 1              | 670                                      | 641  | 610  | 580  | 551  |
| High            |                     |                       | 2                  | 707            | 680                                      | 651  | 621  | 592  |      |
| P-S51A1-B24A-A  | S51A1               | Red Wire              | Factory            | 3              | 707                                      | 678  | 650  | 611  | 576  |
|                 |                     |                       | High               | 2              | 803                                      | 776  | 753  | 726  | 690  |
|                 | G-Continuous Fan    | Black Wire            | -                  | 5              | 348                                      | 295  | 247  | 201  | 176  |
|                 | B24A                | Blue Wire             | Factory            | 1              | 831                                      | 806  | 780  | 754  | 728  |
| High            |                     |                       | (1&4)*             | 993            | 972                                      | 948  | 926  | 903  |      |
| P-S51A2-B30A-A  | S51A2               | Red Wire              | Factory            | 3              | 707                                      | 678  | 650  | 611  | 576  |
|                 |                     |                       | High               | 2              | 803                                      | 776  | 753  | 726  | 690  |
|                 | G-Continuous Fan    | Black Wire            | -                  | 5              | 348                                      | 295  | 247  | 201  | 176  |
|                 | B30A                | Blue w / White        | Low Stage-Factory  | 1              | 537                                      | 504  | 468  | 428  | 382  |
|                 |                     |                       | Low Stage-High     | 2              | 755                                      | 727  | 698  | 668  | 639  |
|                 |                     | Blue Wire             | High Stage-Factory | 3              | 954                                      | 932  | 910  | 887  | 867  |
| High Stage-High |                     |                       | (1&4)*             | 993            | 972                                      | 948  | 926  | 903  |      |

**AIR FLOW**

**TABLE 3. cont**

| Model          | Heating/<br>Cooling | Actual Wire<br>Colour | Setting            | Speed<br>Tap # | SCFM at External Static Pressure (in.WC) |      |      |      |      |
|----------------|---------------------|-----------------------|--------------------|----------------|--|------|------|------|------|
|                |                     |                       |                    |                | 0.1"                                     | 0.2" | 0.3" | 0.4" | 0.5" |
| P-S64B1-B18A-A | S64B1               | Red Wire              | Factory            | 2              | 931                                      | 901  | 872  | 840  | 818  |
|                | G-Continuous Fan    | Black Wire            | -                  | 5              | 348                                      | 295  | 247  | 201  | 176  |
|                | B18A                | Blue Wire             | Factory            | 1              | 670                                      | 641  | 610  | 580  | 551  |
|                |                     |                       | High               | 2              | 707                                      | 680  | 651  | 621  | 592  |
| P-S64B1-B24A-A | S64B1               | Red Wire              | Factory            | 2              | 931                                      | 901  | 872  | 840  | 818  |
|                | G-Continuous Fan    | Black Wire            | -                  | 5              | 348                                      | 295  | 247  | 201  | 176  |
|                | B24A                | Blue Wire             | Factory            | 1              | 831                                      | 806  | 780  | 754  | 728  |
|                |                     |                       | High               | (1&4)*         | 993                                      | 972  | 948  | 926  | 903  |
| P-S64B2-B30A-A | S64B2               | Red Wire              | Factory            | 2              | 931                                      | 901  | 872  | 840  | 818  |
|                | G-Continuous Fan    | Black Wire            | -                  | 5              | 348                                      | 295  | 247  | 201  | 176  |
|                | B30A                | Blue w / White        | Low Stage-Factory  | 1              | 537                                      | 504  | 468  | 428  | 382  |
|                |                     |                       | Low Stage-High     | 2              | 755                                      | 727  | 698  | 668  | 639  |
|                |                     | Blue Wire             | High Stage-Factory | 3              | 954                                      | 932  | 910  | 887  | 867  |
|                |                     |                       | High Stage-High    | (1&4)*         | 993                                      | 972  | 948  | 926  | 903  |

**\* IMPORTANT:** When using the B24A & B30A high tap, connect the Blue Wire to both taps (1&4).  
**Speed taps must be connected as per Actual wire indicated above to perform the required function.**

## WALL SLEEVE DIMENSIONS

TWO DIFFERENT WALL SLEEVE MODELS ARE DEPICTED BELOW:

**NOTE:**

TO IMPROVE RIGIDITY AND REDUCTION IN VIBRATION WALL MOUNTING BRACKETS CAN BE USED TO AFFIX WALL SLEEVE TO BUILDING SUB STRUCTURE FROM INSIDE OR OUTSIDE OF THE BUILDING. ENGINEER/ARCHITECT TO CONSULT WITH CUSTOMER SOLUTIONS IF CLARIFICATION IS REQUIRED TO DETERMINE BRACKET LOCATION FOR SETTING THE DESIRED DEPTH OF WALL SLEEVE INTO WALL.

- CWSMUA
- CWSMUA19

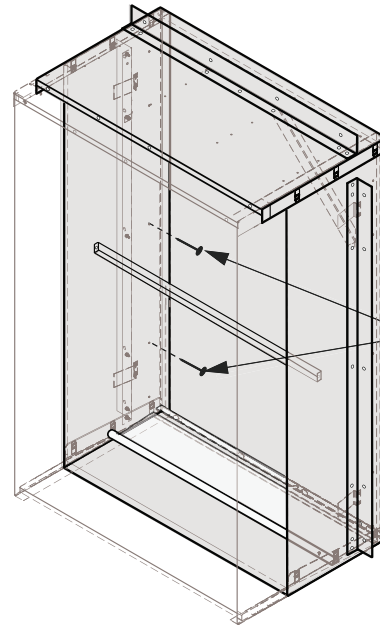

WALL SLEEVE IS DIRECTLY LAGGED TO WALL SUBSTRUCTURE.

DIMENSIONS FOR THE TOP PANEL (ITEM 1):

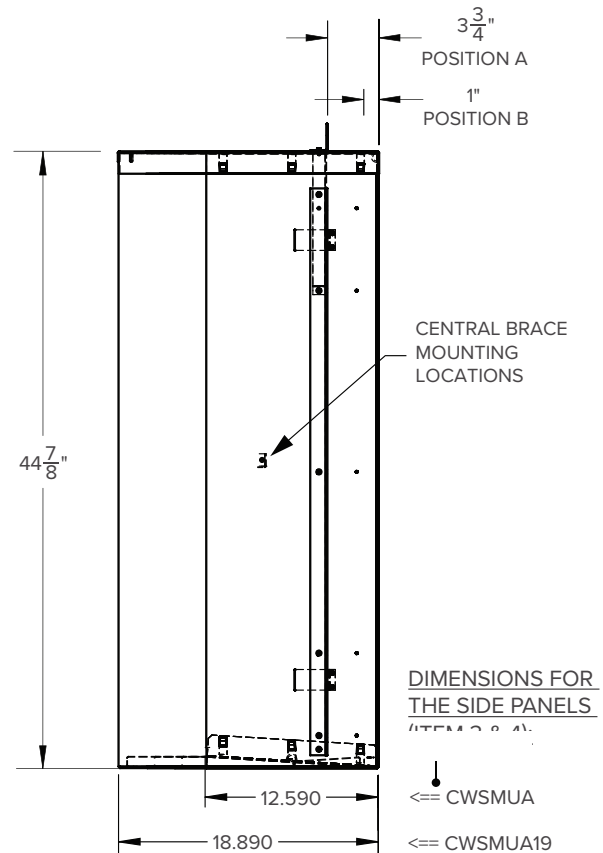
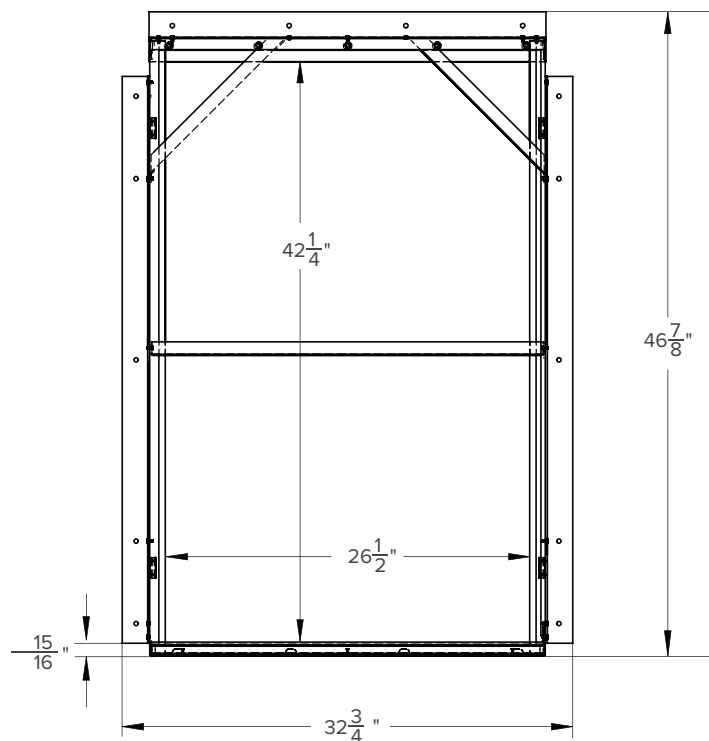
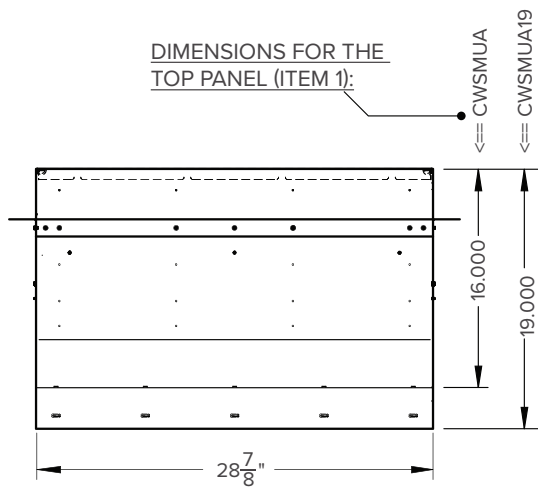
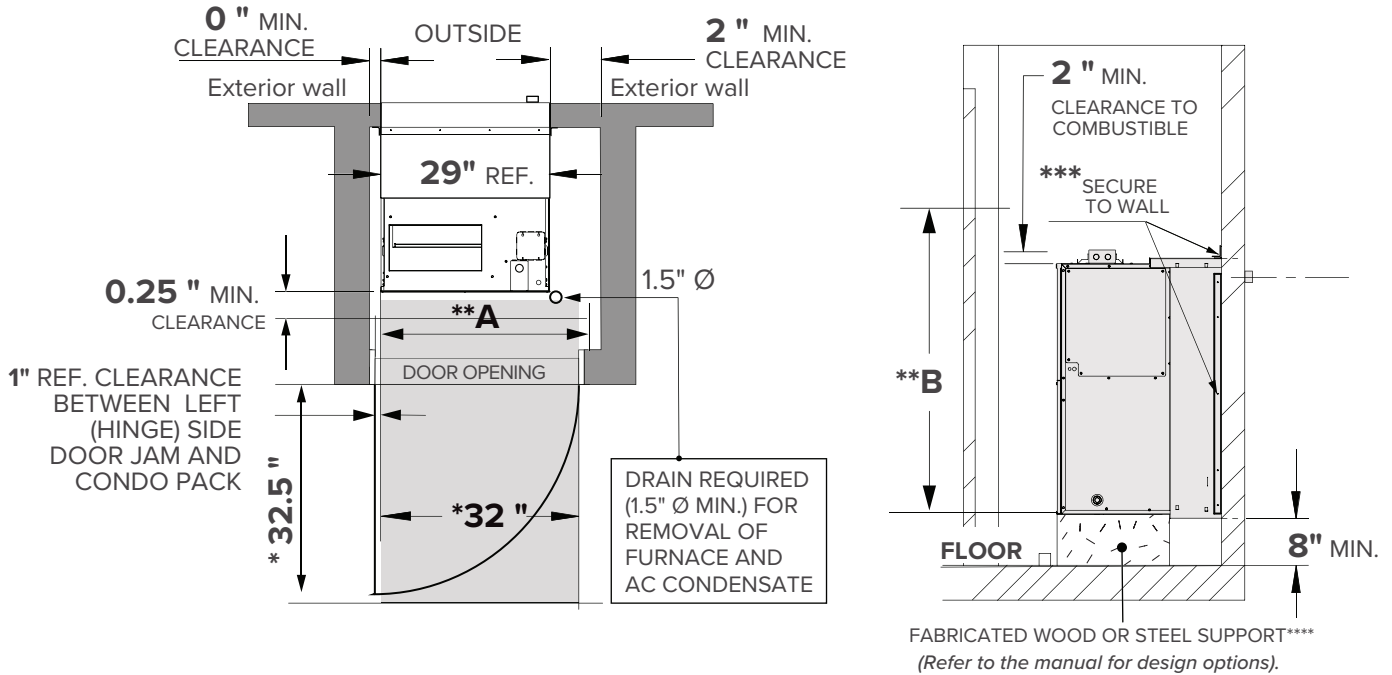

FIGURE 1

**MINIMUM CLEARANCE**

REQUIRED DUE TO UNIT'S DIMENSION & SAFETY STANDARD



**NOTE**

**ADEQUATE SERVICE CLEARANCE MUST BE PROVIDED IN FRONT OF THE UNIT.**

- \*\*\*\* In certain jurisdictions, combustible material is not allowed to be exposed to return air. For such scenarios, refer to installation manual for alternate design options.
- \*\*\* Engineer/Architect - to consult with customer solutions if clarification is required to determine bracket location for setting the desired depth of Wall Sleeve into wall.
- \*\* A clear and unobstructed passageway (dimension AxB) shall be provided to the unit, in accordance with the requirements of the local authorities having jurisdiction and with the National Fuel Gas Code, ANSI Z223.1 (latest edition) and the National Electrical Code in the United States or CAN/CGA-B149.1 & .2 and the Canadian Electrical Code CSA C22.1 Part 1 (latest edition) in Canada.
- \* The 32 " x 32.5 " unobstructed clearance is required in front of the unit for complete removal of heating and cooling module. Check local building codes for other applicable requirements.

**IMPORTANT:**

Prior to constructing interior closet walls in close proximity to the wall sleeve, the sealing of the wall sleeve and cabinet should be completed. Sealing after the walls are constructed can be difficult. Poor sealing will result in cold air infiltration that will affect Condo Pack. Refer to section "Sealing: Wall Sleeve and Condo Pack cabinet".

FIGURE 2

**IMPORTANT:**

MINIMUM REQUIRED VERTICAL CLEARANCE OF A VENT TERMINAL AND OVERHANGING STRUCTURE FROM THE TOP OF THE GAS VENT IS 12" (MORE THAN 12" IS RECOMMENDED). CHECK LOCAL BUILDING CODES FOR OTHER REQUIREMENTS.

**NOTE:**

IT IS ALWAYS A GOOD PRACTICE TO MAXIMIZE THE CLEARANCE AS MUCH AS POSSIBLE BETWEEN VENT TERMINAL AND SURROUNDING STRUCTURES TO AVOID ANY POTENTIAL DAMAGE, DEGRADATION AND ICING, SINCE THE FLUE GASES CONTAIN WATER VAPOR AND ARE TYPICALLY MILDLY ACIDIC. CONSULT WITH EXTERIOR WALL FINISH MANUFACTURER FOR MORE INFORMATION.

**NOTE** \*\*\*\* Refer to:  
 \*\*\* Enclosure For Condo Pack Figure 1, page 5.

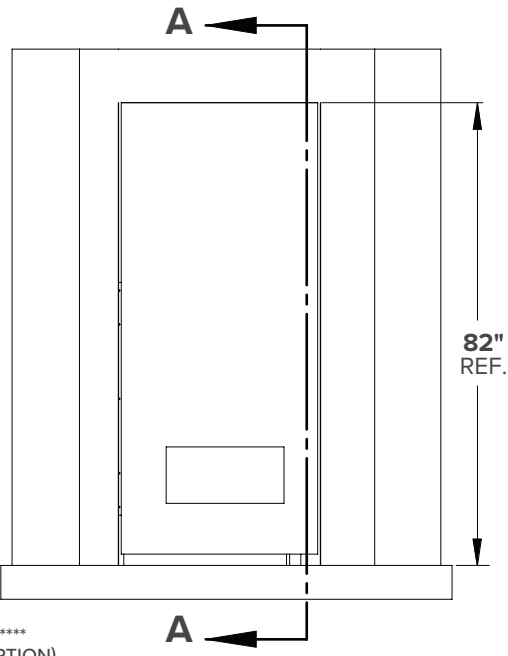
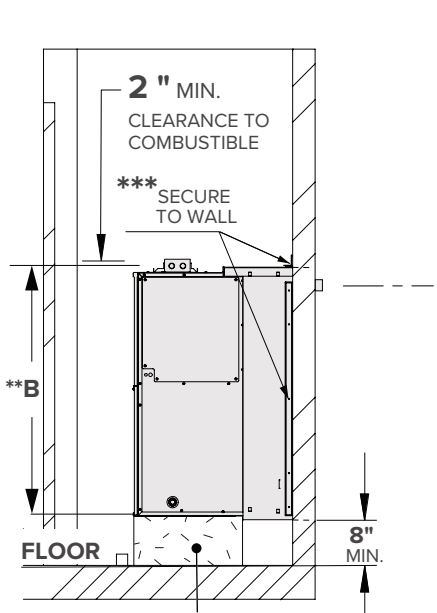

SUPPORT OUVRÉ EN BOIS OU EN MÉTAL POUR L'APPAREIL \*\*\*\*  
 (REPORTEZ-VOUS AU MANUEL POUR LES OPTIONS DE CONCEPTION).

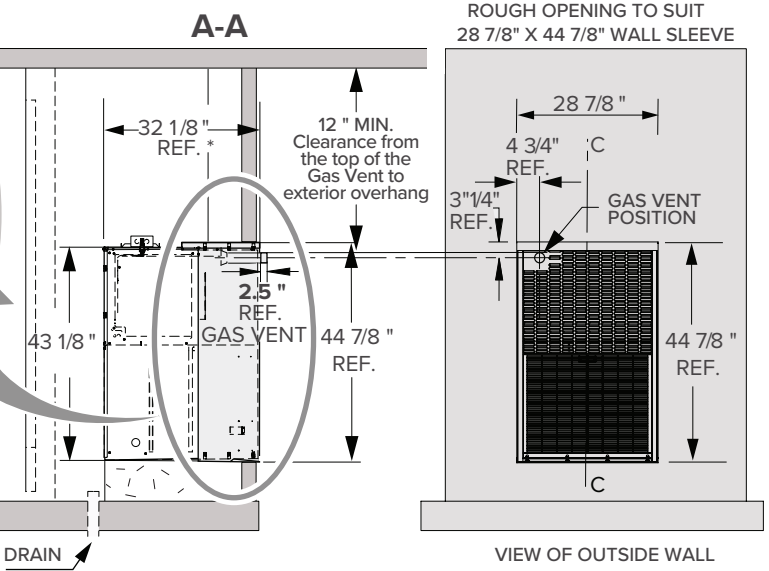
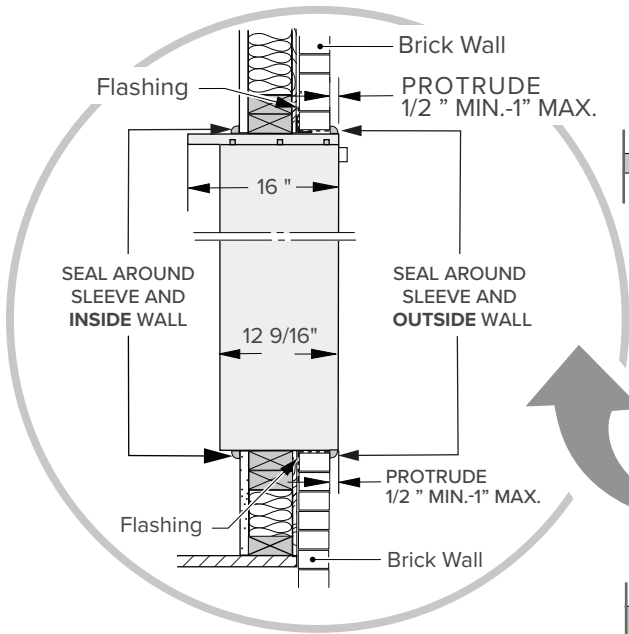

CONDO PACK SHOWN IN WALL SLEEVE

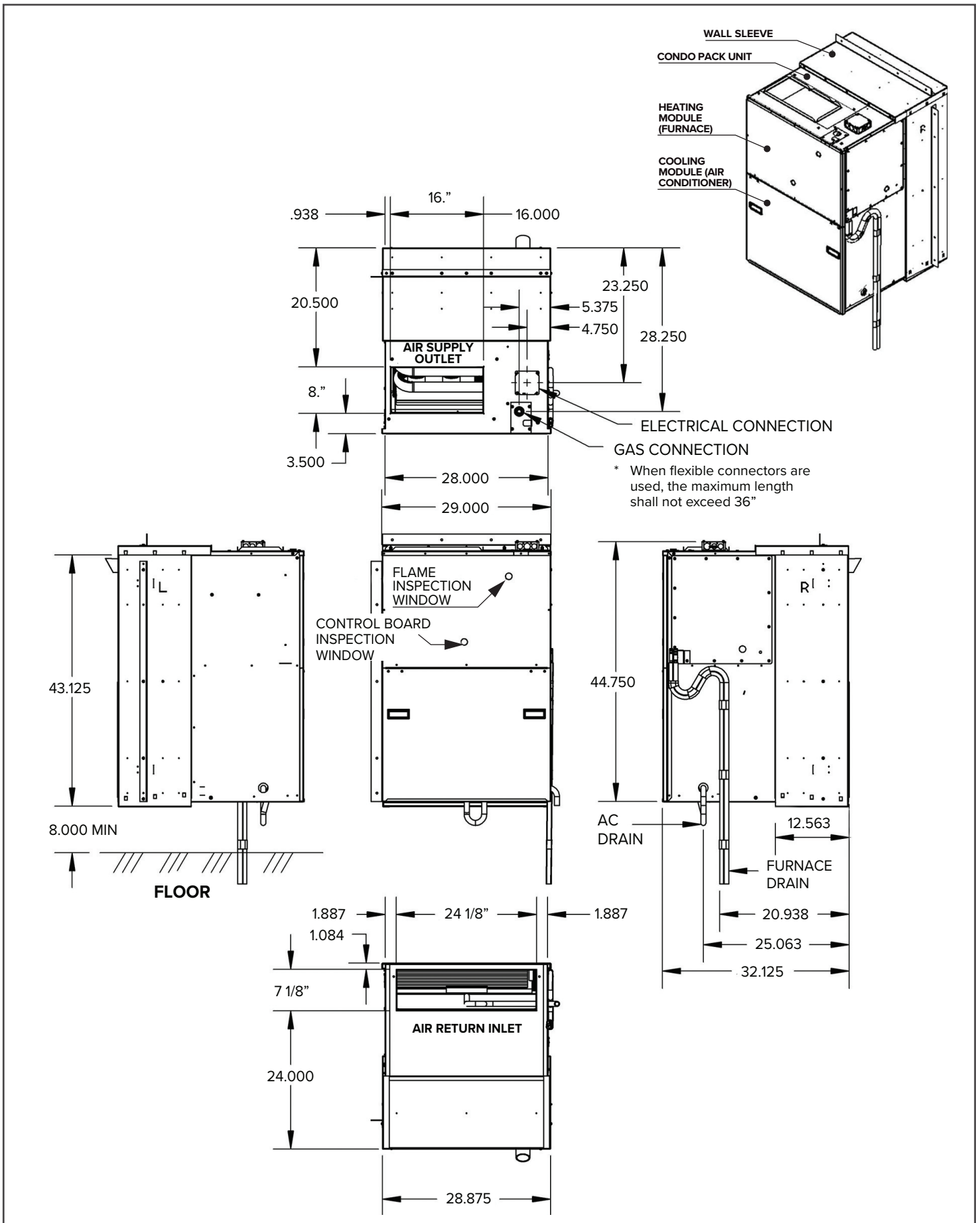

SEALING: WALL SLEEVE AND CONDO PACK CABINET

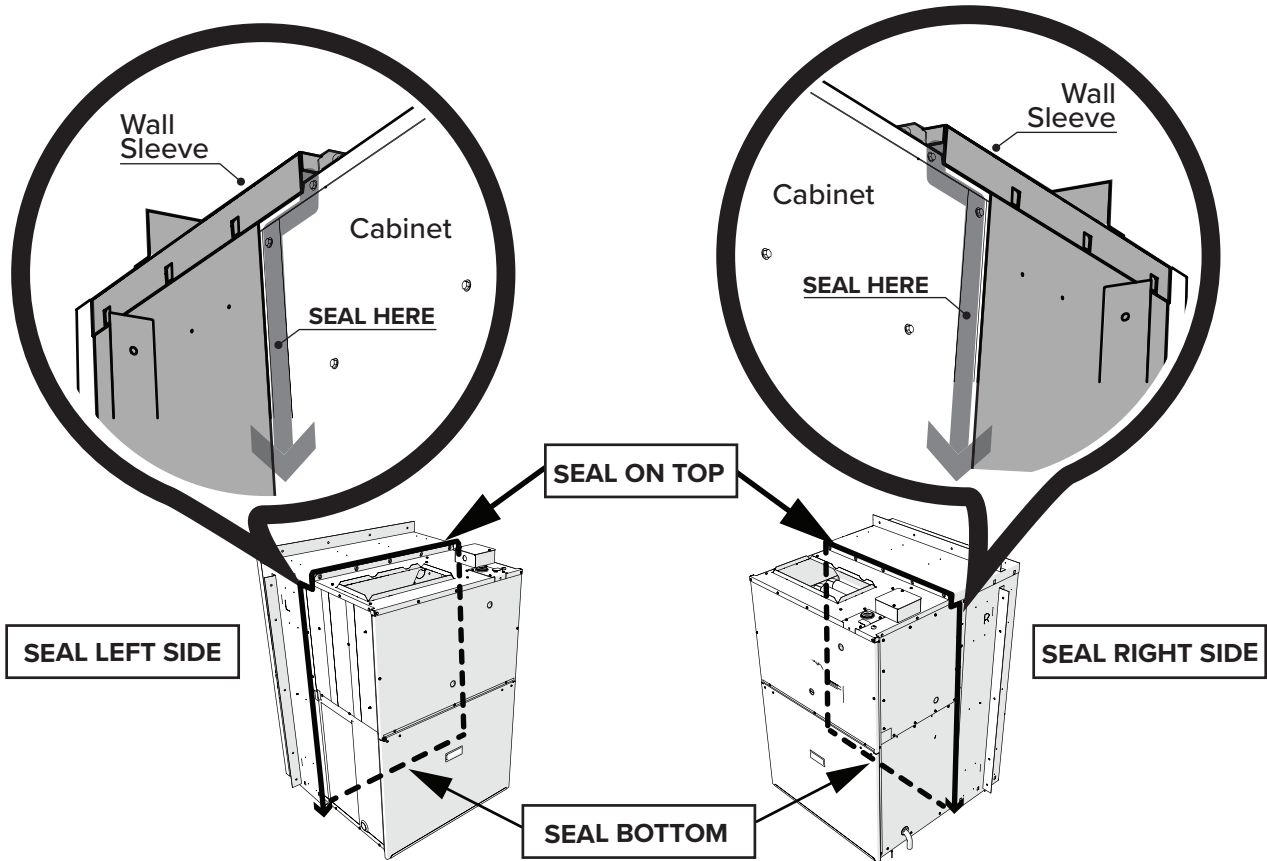

Fill the clearance space between the sleeve and the cabinet with non-hardening caulking compound or non-expanding insulation foam as a protection against the snow, water, moisture and air infiltration.

|   |
|---|
| <p><b>⚠ IMPORTANT ⚠</b></p>   |
| <p>THE CLEARANCE SPACE BETWEEN THE WALL SLEEVE AND THE CABINET MUST BE COMPLETELY SEALED ON ALL FOUR SIDES IN ORDER TO PREVENT THE MOISTURE AND AIR INFILTRATION.</p>   |
| <p><b>⚠ WARNING ⚠</b></p>   |
| <p>THESE INSTRUCTIONS ARE INTENDED AS AN AID TO QUALIFIED SERVICE PERSONNEL FOR PROPER INSTALLATION, ADJUSTMENT AND OPERATION OF THE UNIT. READ THESE INSTRUCTIONS THOROUGHLY BEFORE ATTEMPTING INSTALLATION OR OPERATION. IMPROPER INSTALLATION, ADJUSTMENT, SERVICE, OR MAINTENANCE CAN CAUSE PROPERTY DAMAGE, PERSONAL INJURY, OR DEATH. FOR INFORMATION AND ASSISTANCE CONSULT A QUALIFIED INSTALLER OR SERVICE AGENCY.</p> |

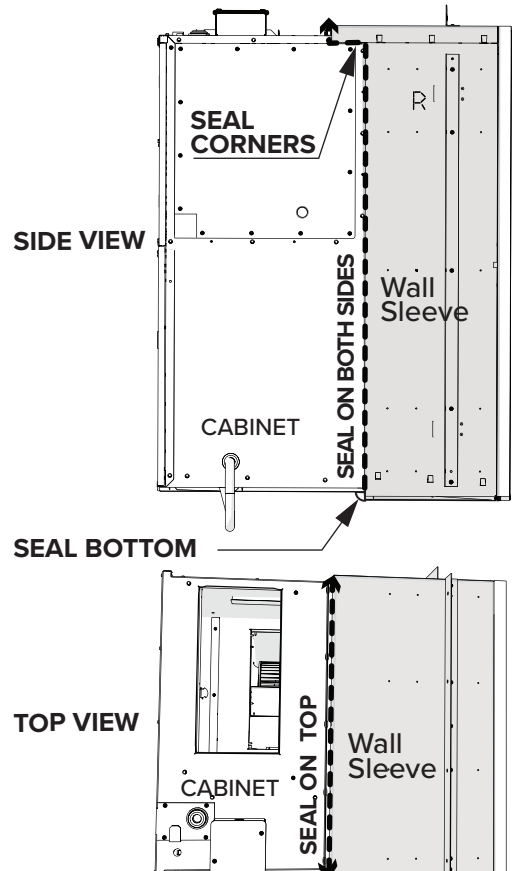





**WOLF STEEL**

24 Napoleon Road, Barrie, Ontario, Canada L4M 0G8

PHONE: 866-820-8686

Website: [www.napoleon.com](http://www.napoleon.com)

General: [hvac@napoleon.com](mailto:hvac@napoleon.com)

Technical inquiries: [hvacsupport@napoleon.com](mailto:hvacsupport@napoleon.com)

