

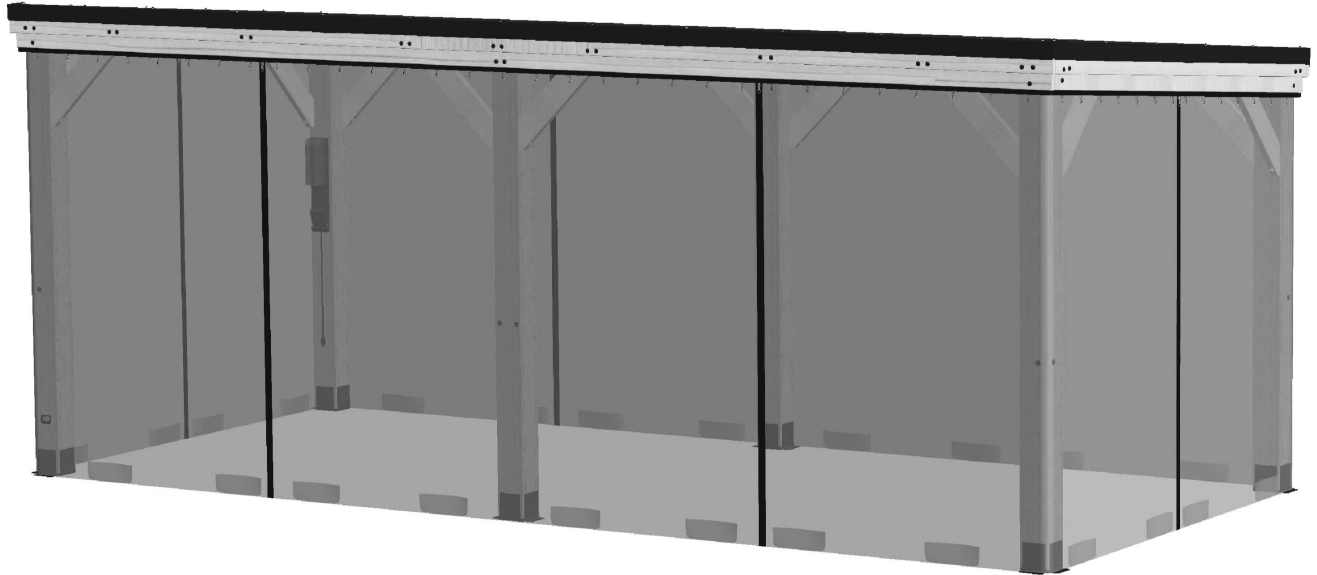

Manufactured by:
Backyard Discovery
3305 Airport Drive, Pittsburg, KS 66762
800-856-4445

Basepoint Business Centre: Rivermead Drive, Westlea, Swindon SN5 7EX Phone: 0800-118-2476 J.P. Coenstraat 7, The Hague, 2595 WP, Netherlands Phone: 08005678990

20x9.5 ARCADIA MOSQUITO MESH KIT MODEL # : 9230279



Please visit www.backyarddiscovery.com
For the most up to date assembly manual, to register your product, or to order
replacement parts *Para obtener instrucciones en español, visite*
www.backyarddiscovery.com

OWNER'S MANUAL - PARTS IDENTIFICATION

HARDWARE COMPONENTS (NOT TO SCALE)

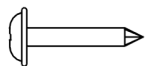

H100392 SCREW PWH BLK
(x106) #8x3/4

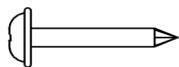

H100797 SCREW PWH BLK
(x8) #8x1

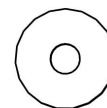

H100478 WASHER BLK
(x12) 8x27

ACCESSORY COMPONENTS (NOT TO SIZE)

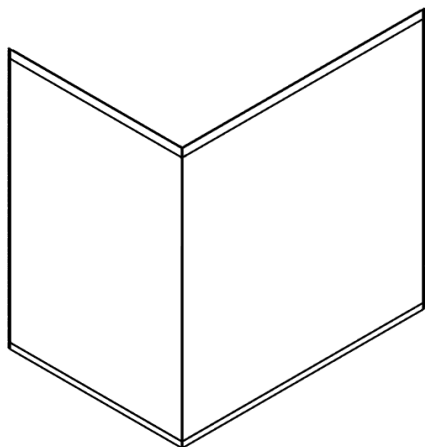

A6P00953 MESH PANEL
(x1)

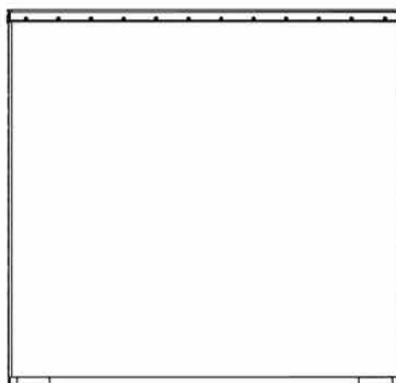

A6P00956 MESH PANEL
(x1)

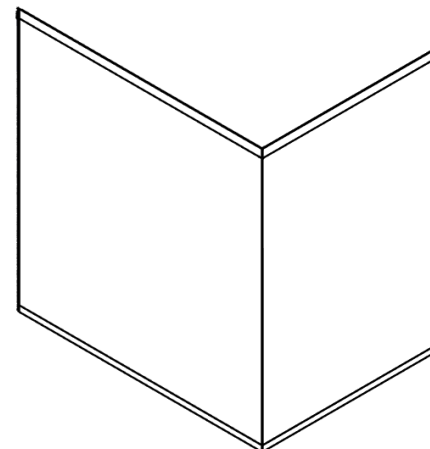

A6P00955 MESH PANEL
(x1)

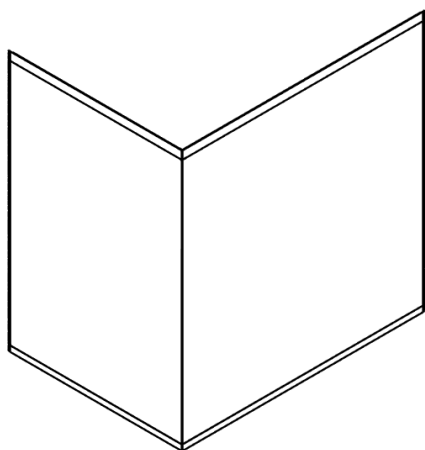

A6P00952 MESH PANEL
(x1)

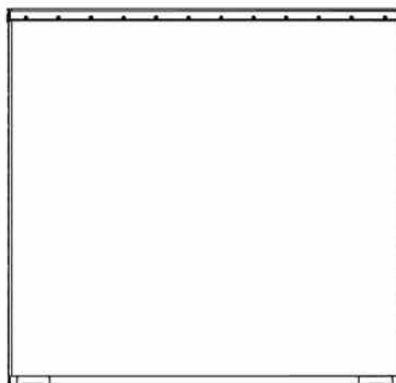

A6P00957 MESH PANEL
(x1)

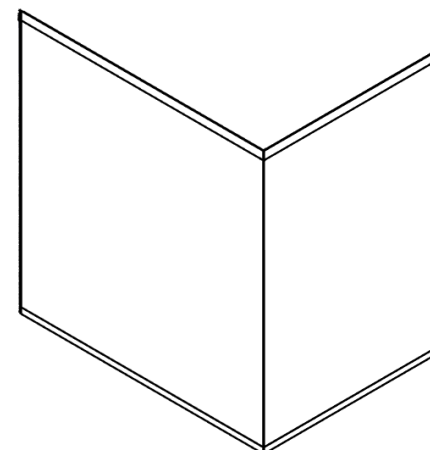

A6P00954 MESH PANEL
(x1)



A6P00752 MESH PANEL TIE
(x6)

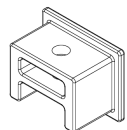

A6P00958 TRACK END CAP
(x8)



A6P0950 MESH PANEL TRACK
(x4)

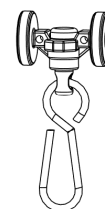

A6P00535 MESH PANEL HOOK
(x94)



A6P00951 MESH PANEL TRACK
(x6)

PRE-ASSEMBLY STEP 1 - SORTING PARTS

It is critical for ease of assembly that you take the time to sort and organize the parts and hardware.

HARDWARE PARTS:

- We recommend that you have a separate table to organize the hardware.
- Hardware bags are printed with a seven-digit, alpha-numeric part number.
- You can organize your hardware by part number or group by hardware type (i.e. bolts, nuts, etc.).
- During assembly you only need to reference the last four digits of the number.

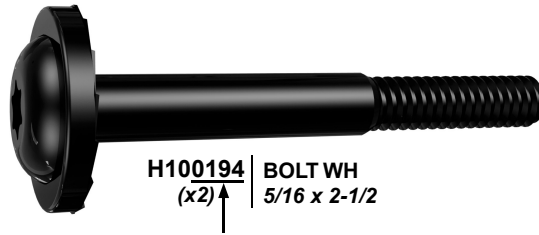

TOOLS REQUIRED:



Cordless Drill or
Electric Drill



Drill Attachments:
Phillips Head



1/8" & 3/8" Drill
Bits



Phillips Screw Driver

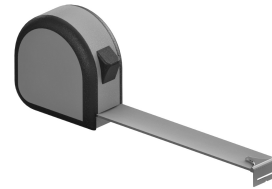

Tape Measure

STEP 1 - TIES

Qty	PART NUMBER	DESCRIPTION
12	H100478	WASHER FLAT 8x27 BLK
12	H100392	SCREW PWH 8x3/4 BLK



A6P00752 MESH PANEL TIE
(x6)

- ATTACH EACH MESH PANEL TIE TO THE POST ASSEMBLY AS SHOWN BELOW.

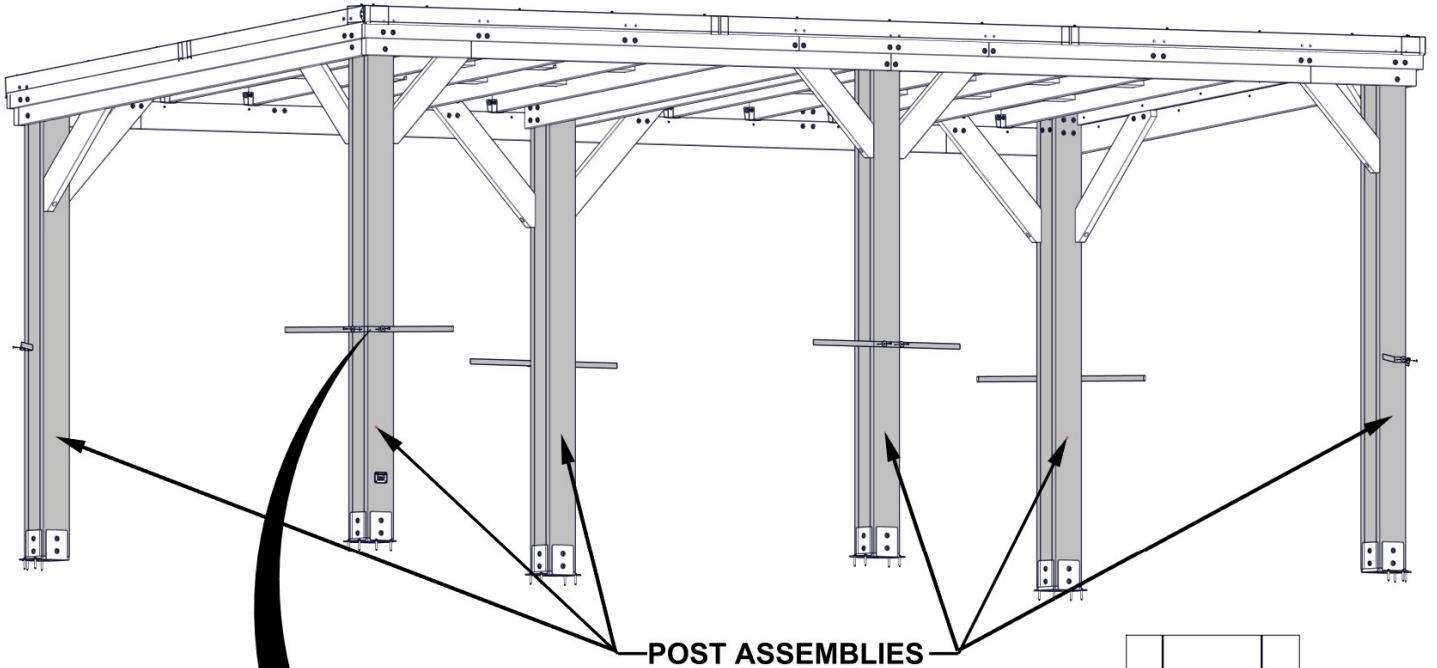

0752 (x6)
MESH PANEL TIE

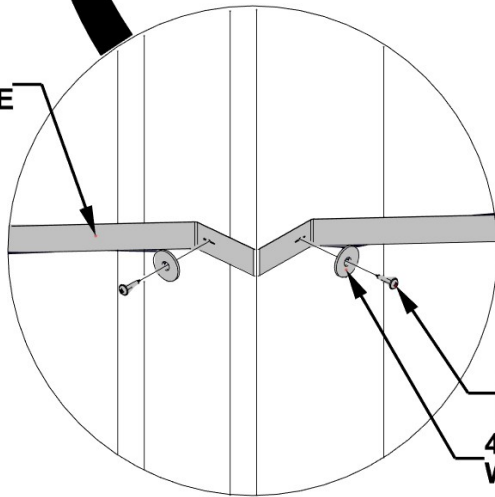

392 (x12)
SCREW - 3/4"
478 (x12)
WASHER - 8x27

39 3/8"
[1000mm]

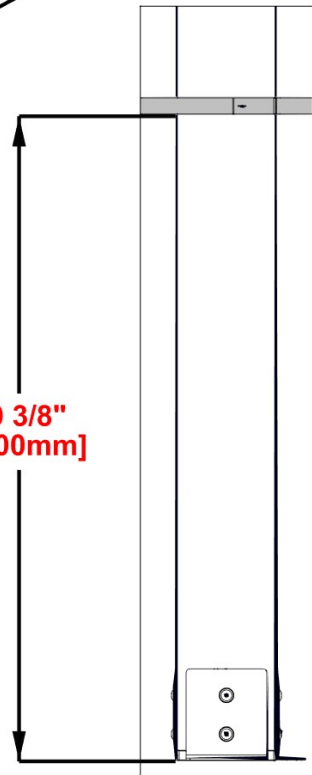

STEP 2 - MEASURE

EXTRA PEOPLE ARE HELPFUL FOR THIS STEP.

- MEASURE & MARK CENTER ON ALL FOUR SIDES OF THE FASCIA BOARD

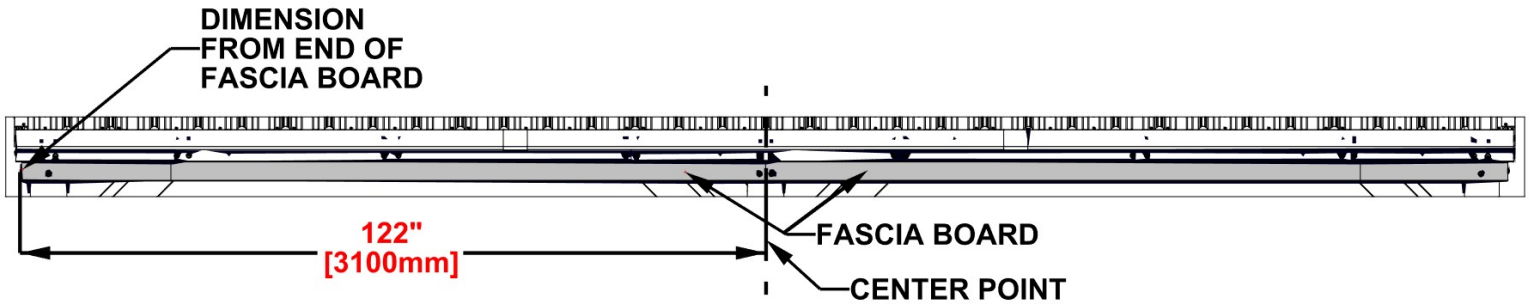
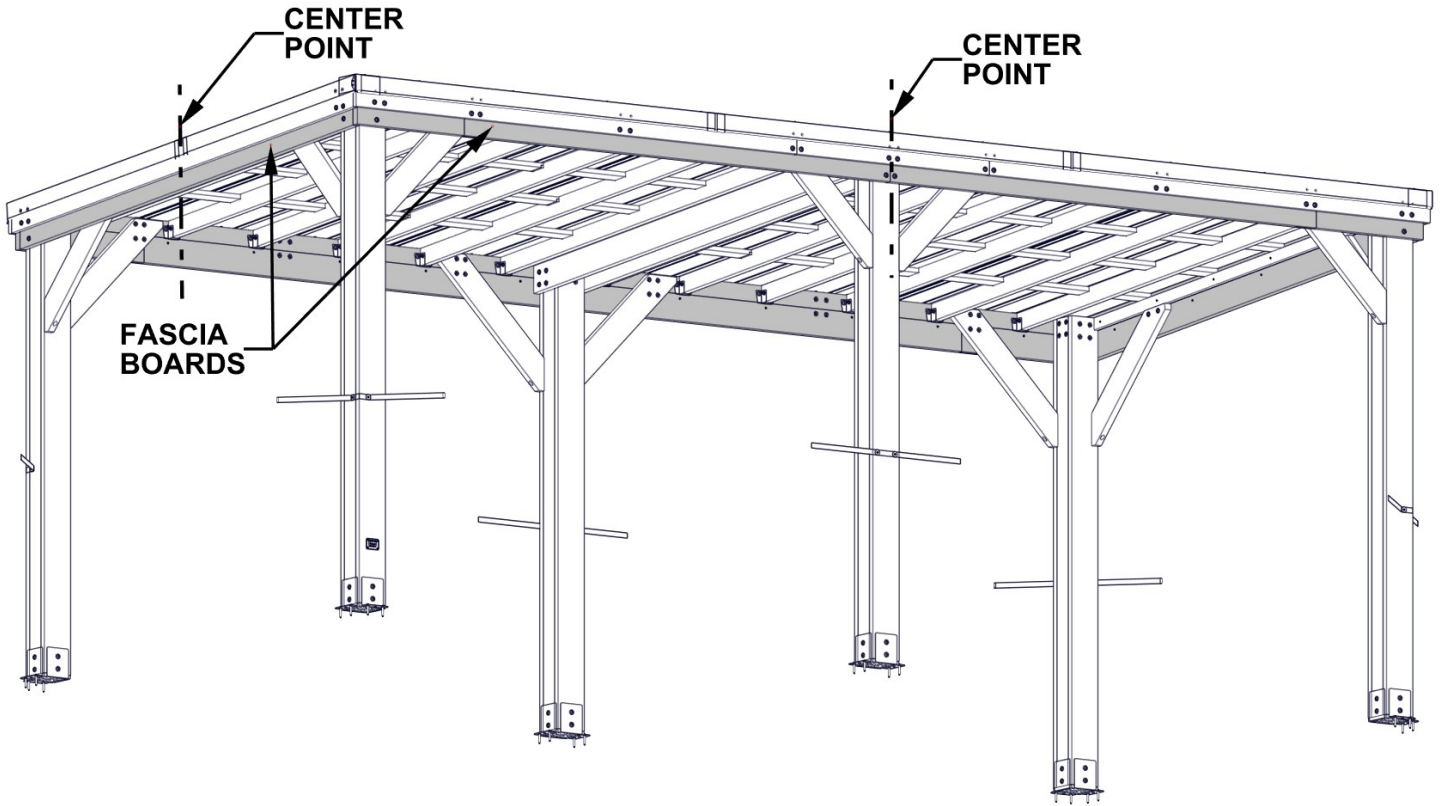

20FT SIDE

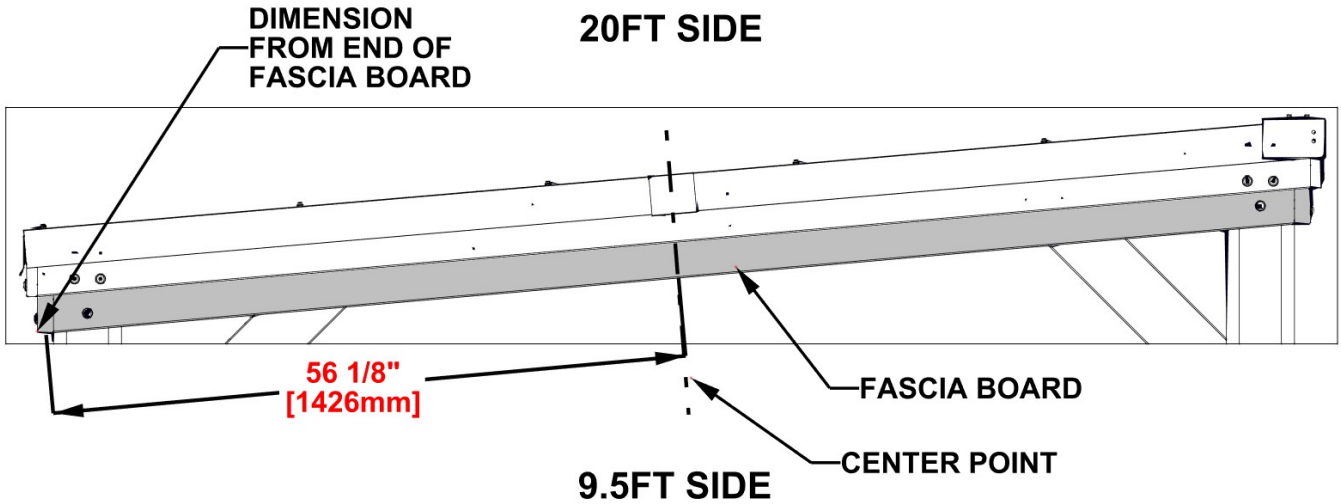

9.5FT SIDE

STEP 3A - TRACKS 9.5FT SIDE

Qty	PART NUMBER	DESCRIPTION
28	H100392	SCREW PWH 8x3/4 BLK



A6P00950 MESH PANEL TRACK
(x4)

EXTRA PEOPLE ARE HELPFUL FOR THIS STEP.

1. BEGINNING AT THE CENTER POINT, MOUNT ONE (0950) TRACK SO THE INSIDE EDGE OF THE TRACK IS FLUSH WITH THE INSIDE EDGE OF THE FASCIA BOARD & FLUSH WITH THE FRONT OF THE POST ASSEMBLY (IMAGE 1).
2. ATTACH AS SHOWN (IMAGE 2).
3. REPEAT STEPS 1-2 FOR THE SECOND TRACK. **NOTE: TRACKS SHOULD BE FLUSH IN THE CENTER**

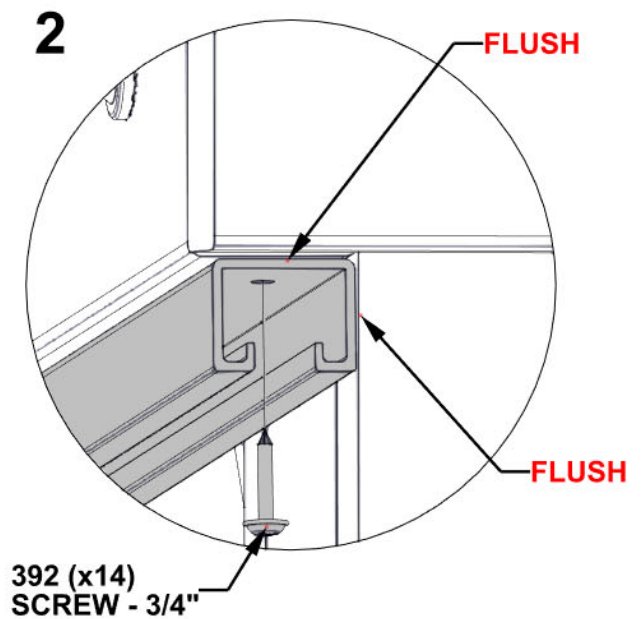
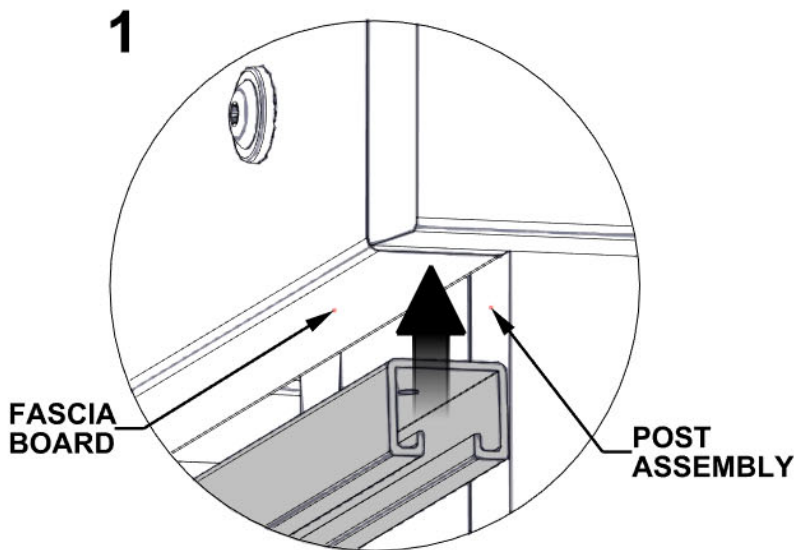
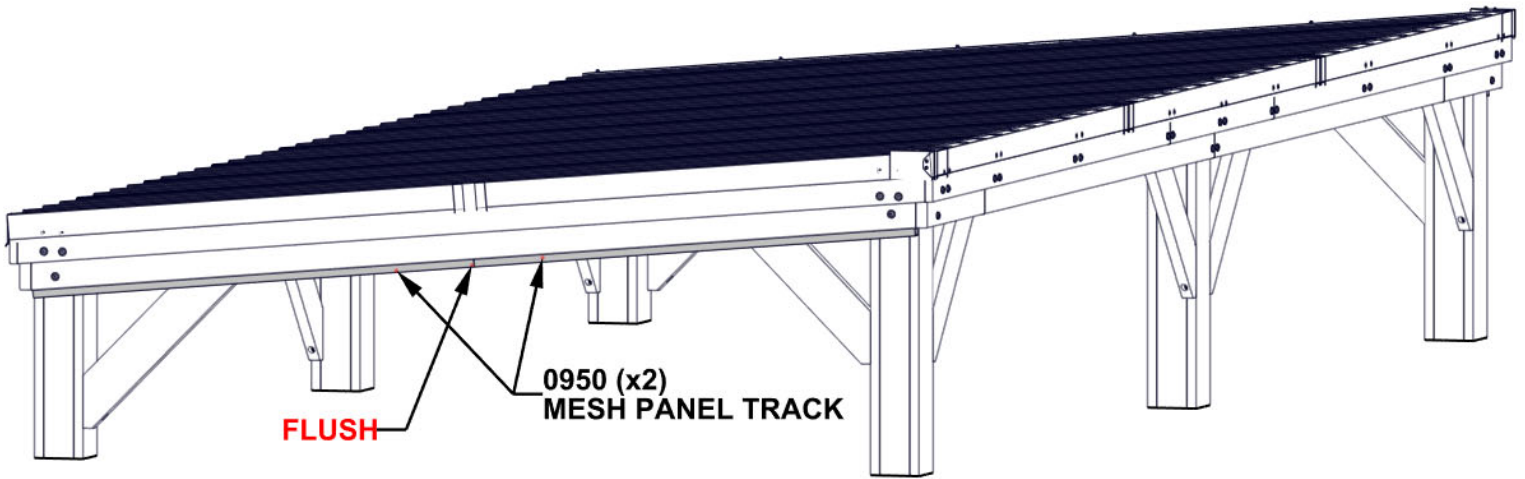

STEP 3B - TRACKS 9.5FT SIDE

Qty	PART NUMBER	DESCRIPTION
4	H100797	SCREW PWH 8x1 BLK

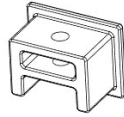
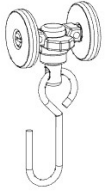

A6P00535 MESH PANEL HOOK
(x28)

A6P00958 TRACK END CAP
(x4)

1. INSERT END CAP AT BOTTOM END OF TRACK FIRST (IMAGE 1 & 2)
2. INSERT 14 HOOKS AS SHOWN AT TOP END OF THE TRACK (IMAGE 3).
3. INSERT END CAPS IN TOP END OF TRACK.
4. REPEAT STEPS 1-3 FOR THE OPPOSITE 9.5FT SIDE.

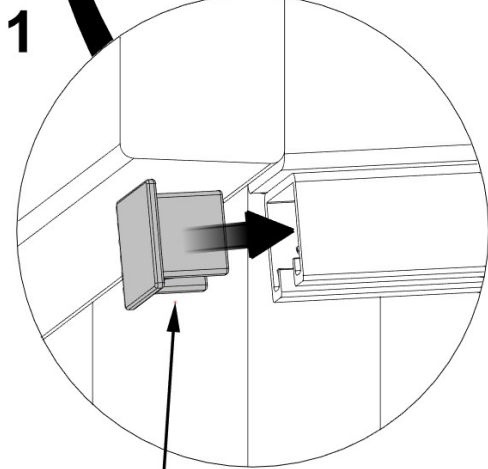
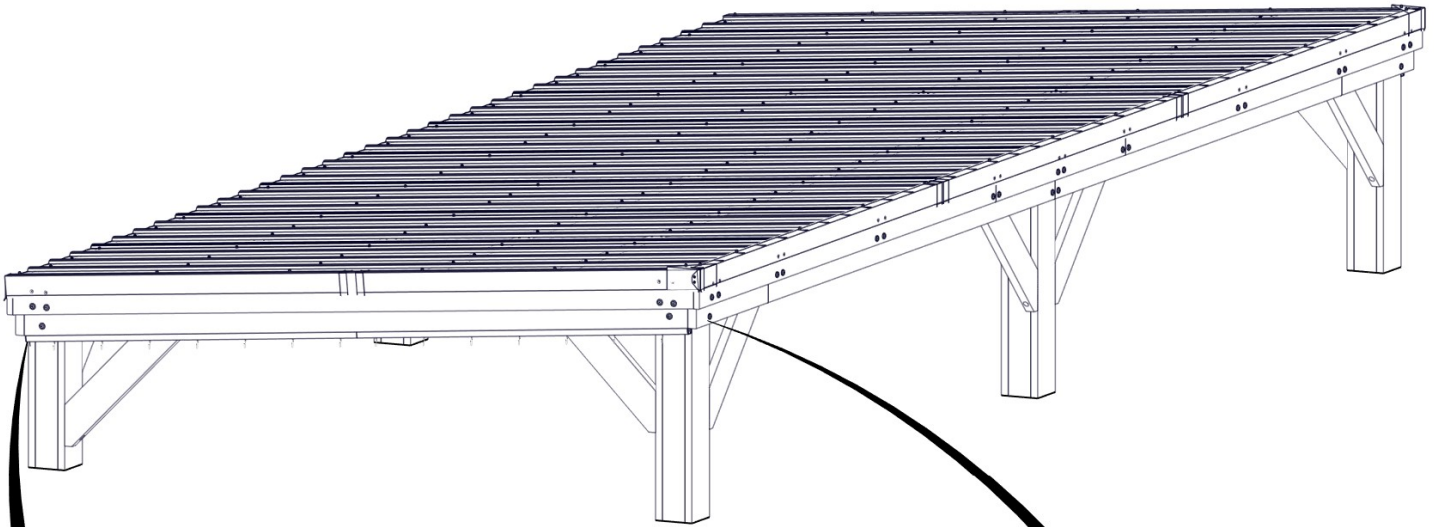

0958 (x2)
TRACK END CAP

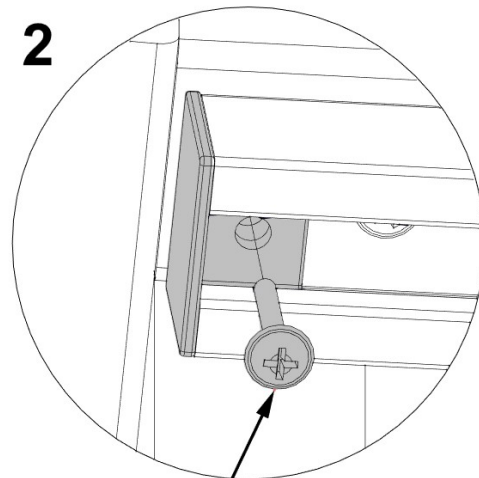

797 (x2)
SCREW - 1"

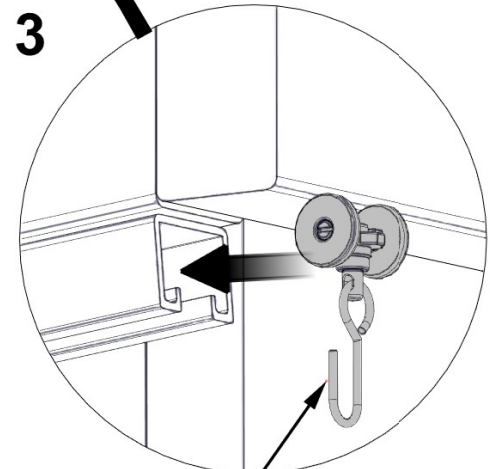

0535 (x14)
MESH PANEL HOOK

STEP 4A - TRACKS 20FT SIDE

Qty	PART NUMBER	DESCRIPTION
66	H100392	SCREW PWH 8x3/4 BLK



A6P00951 MESH PANEL TRACK
(x6)

EXTRA PEOPLE ARE HELPFUL FOR THIS STEP.

1. START AT ONE END OF THE 20FT SIDE AND MEASURE 3/8" (8mm) FROM THE END OF THE BOARD ABOVE THE TRACK. (IMAGE 1)
2. ATTACH AS SHOWN (IMAGE 2).
3. ALIGN SECOND TRACK END FLUSH WITH EXISTING TRACK 0951 END, THEN CONTINUE TO ATTACH REMAINING TRACK PARTS WHILE KEEPING THE TRACK ALIGNMENT.
4. REPEAT STEPS 1-6 FOR THE OPPOSITE 20FT SIDE.

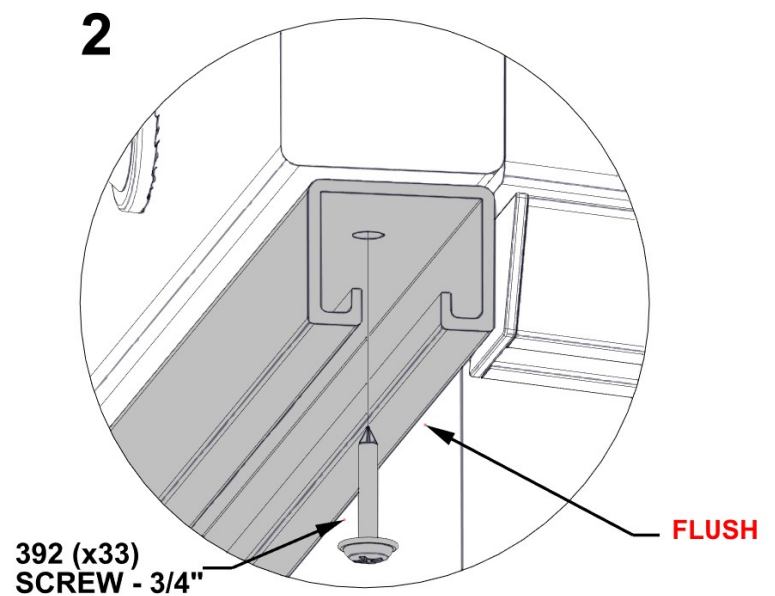
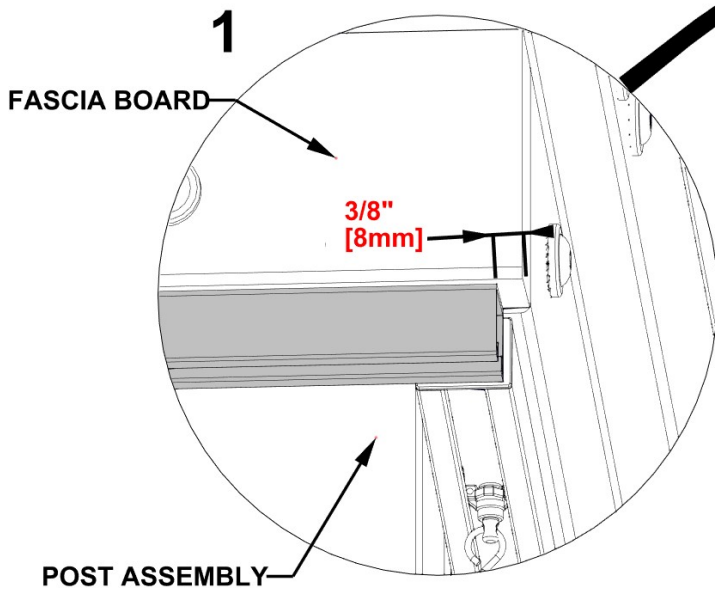
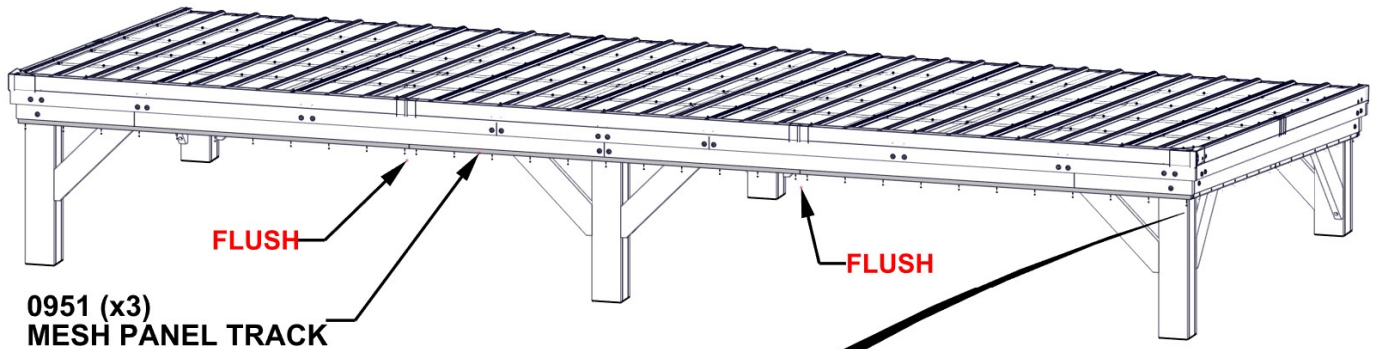

STEP 4B - TRACKS 20FT SIDE

Qty	PART NUMBER	DESCRIPTION
4	H100797	SCREW PWH 8x1 BLK

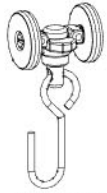

A6P00535 MESH PANEL HOOK
(x62)

A6P00958 TRACK END CAP
(x4)

1. INSERT 31 HOOKS AS SHOWN (IMAGE 1).
2. INSERT END CAPS IN BOTH ENDS OF THE TRACK (IMAGE 2).
3. ATTACH END CAPS AS SHOWN (IMAGE 3).
4. REPEAT STEPS 1-3 FOR THE SECOND TRACK.
5. REPEAT ALL STEPS FOR 4A & 4B FOR THE OPPOSITE 20FT SIDE.

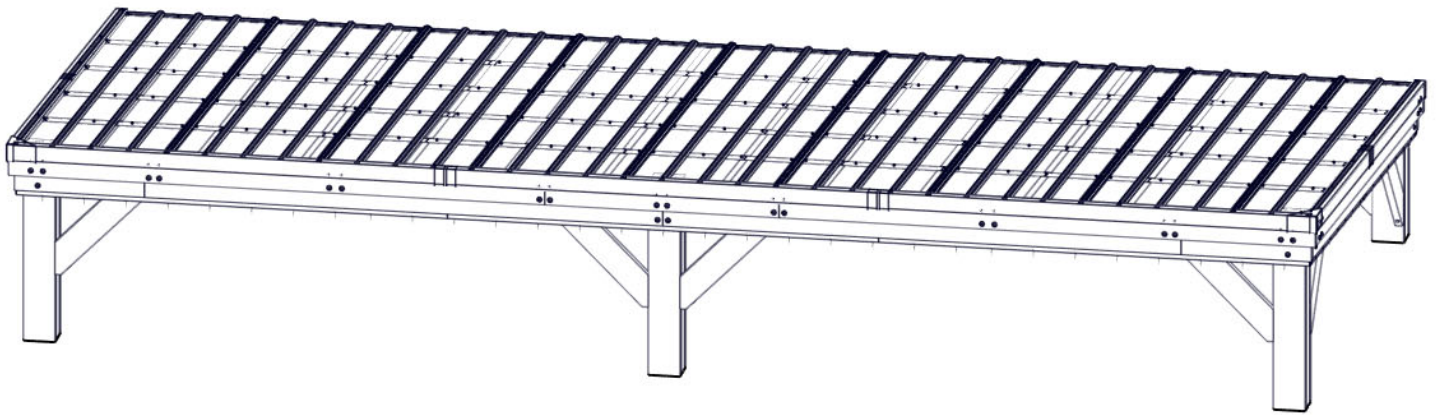

0958 (x2)
TRACK END CAP

1

2

3

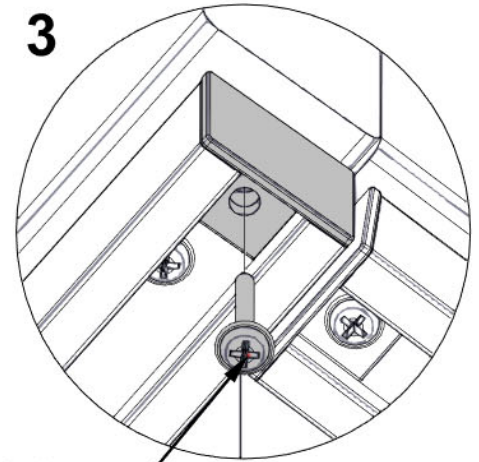
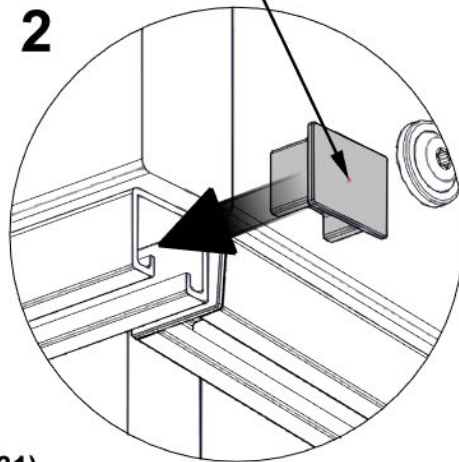
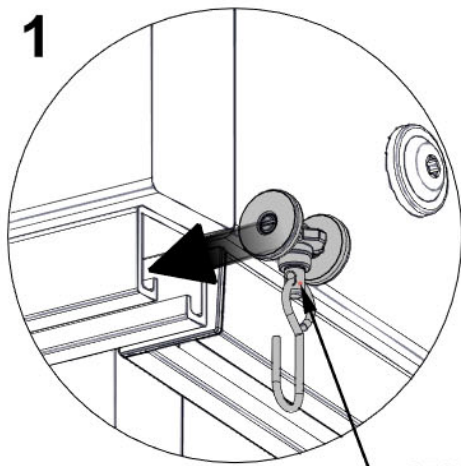

0535) (x31)
MESH PANEL HOOK

797 (x2)
SCREW - 1"

STEP 5 - MESH PANELS



A6P00955 MESH PANEL (x1)



A6P00952 MESH PANEL (x1)

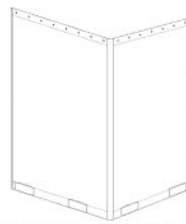

A6P00954 MESH PANEL (x1)



A6P00953 MESH PANEL (x1)



A6P00957 MESH PANEL (x1)



A6P00956 MESH PANEL (x1)

EXTRA PEOPLE ARE HELPFUL FOR THIS STEP.

1. BOTH 20FT SIDES WILL HAVE A FLAT PANEL IN THE MIDDLE & A PANEL THAT WRAPS AROUND THE OUTSIDE OF THE POSTS AND COVERS PART OF THE 20FT SIDE AND ONE HALF OF THE 9.5FT SIDE.
2. THE POCKETS AT THE BOTTOM OF THE PANELS SHOULD BE FACING THE INSIDE OF THE GAZEBO. **ZIPPERS WILL NOT ALIGN IF PANELS ARE FACING THE WRONG DIRECTION.**
3. BEGIN HANGING MESH PANEL A6P00956 ON THE 9TH HOOK FROM THE LEFT OF THE 20FT SIDE (USING 15 HOOKS). BEGIN HANGING MESH PANEL A6P00955 ON THE HOOK TO THE RIGHT OF MESH PANEL A6P00956 (USING 9 HOOKS). CONTINUE AROUND THE POST TO THE 9.5FT SIDE (USING 7 HOOKS).
4. CONTINUE ADDING PANELS FOLLOWING THE ORDER SHOWN ON THE "TOP VIEW" DETAIL.

