

# 2400351 SPRUCE HOLLOW Container Loading Diagram

( 1 set=3 boxes, 86 sets/40HQ, 20 pallets/ 40HQ, Gross Weight:17684kg)

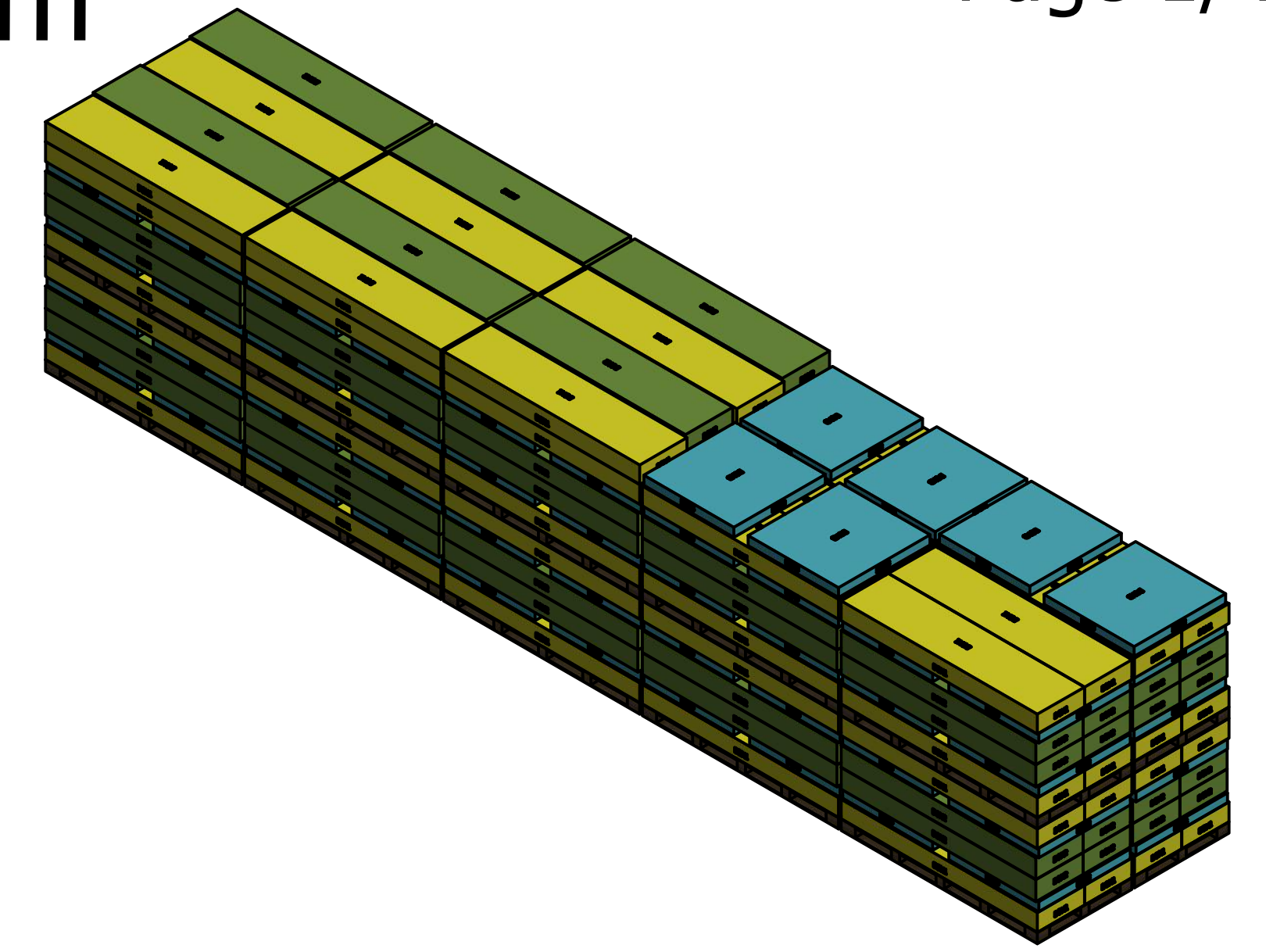

Top view

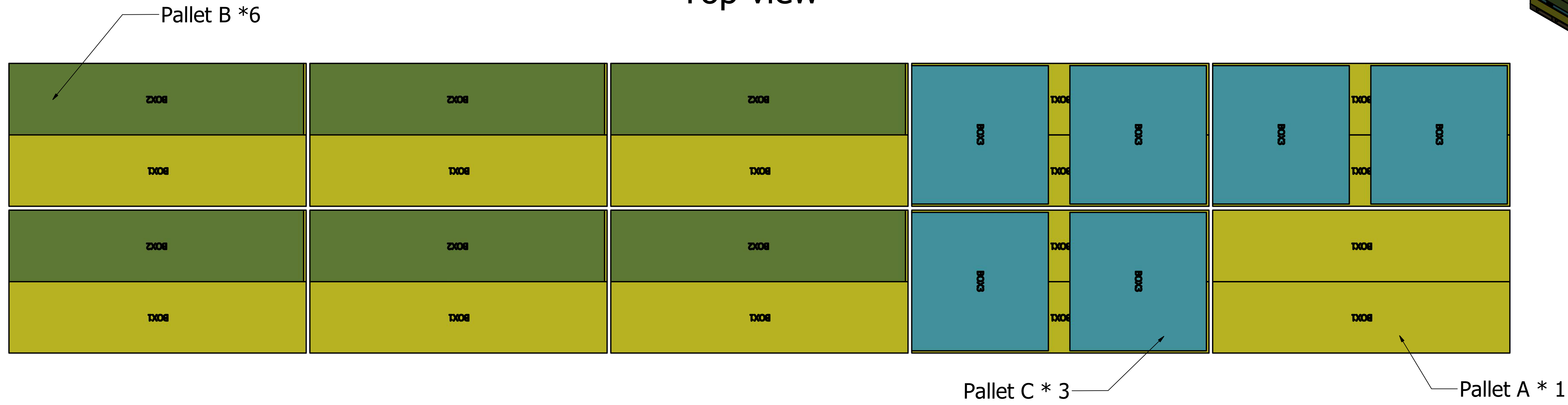

Side view

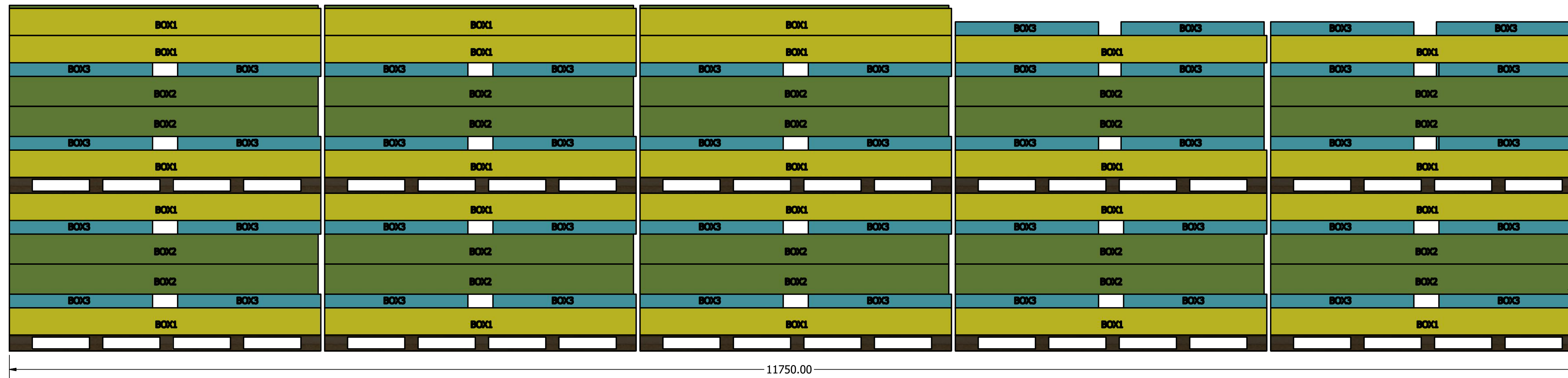

End view

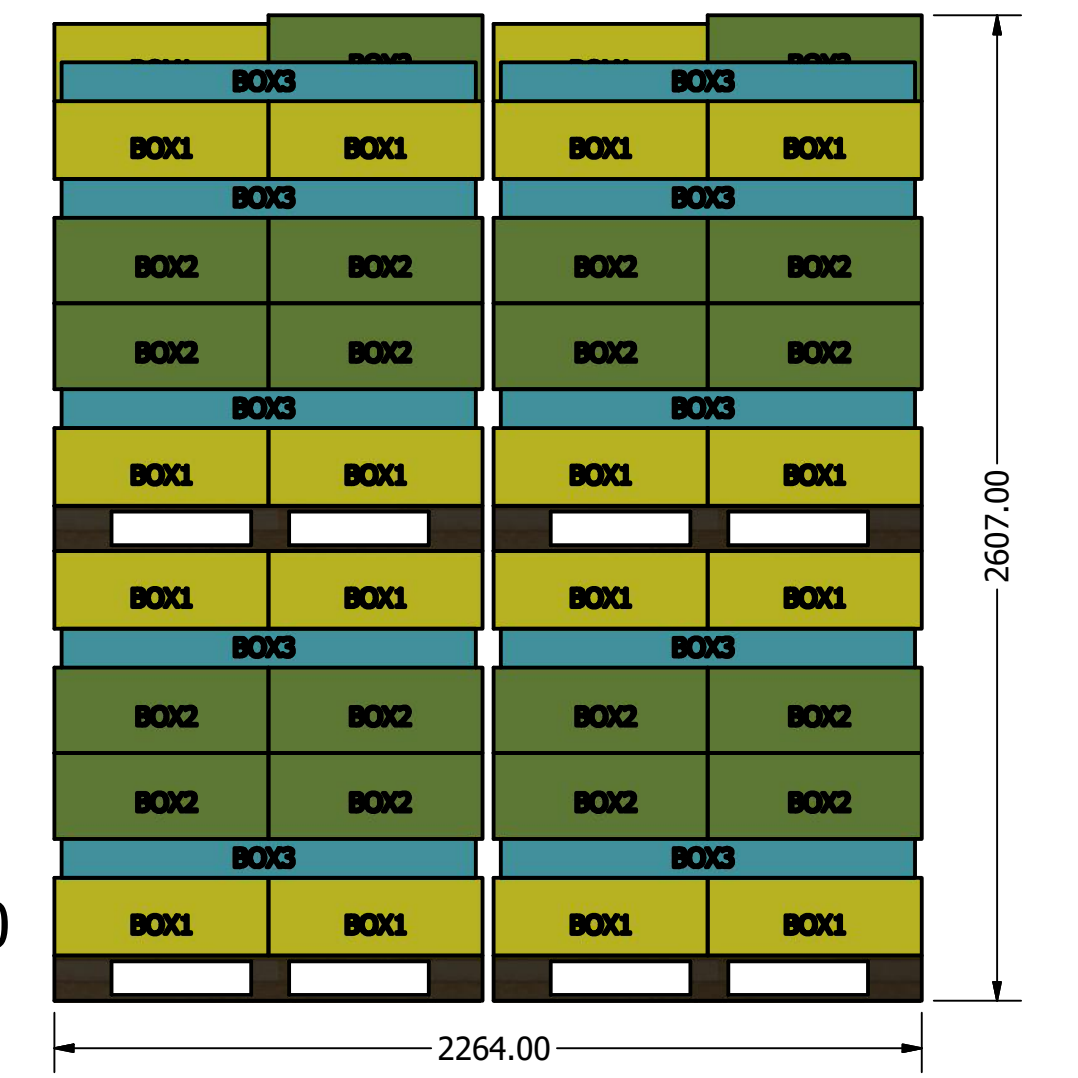

Pallet A (4 sets) \* 11  
 Pallet B (4 sets+BOX1\*1+BOX2\*1) \* 6  
 Pallet C (4 sets+BOX3\*2) \* 3

DRAWN Rudy		TITLE		
CHECKED				
QA				
MFG				
APPROVED				
		SIZE D	DWG NO	REV
		SCALE 1 / 20	SHEET 1 OF 1	

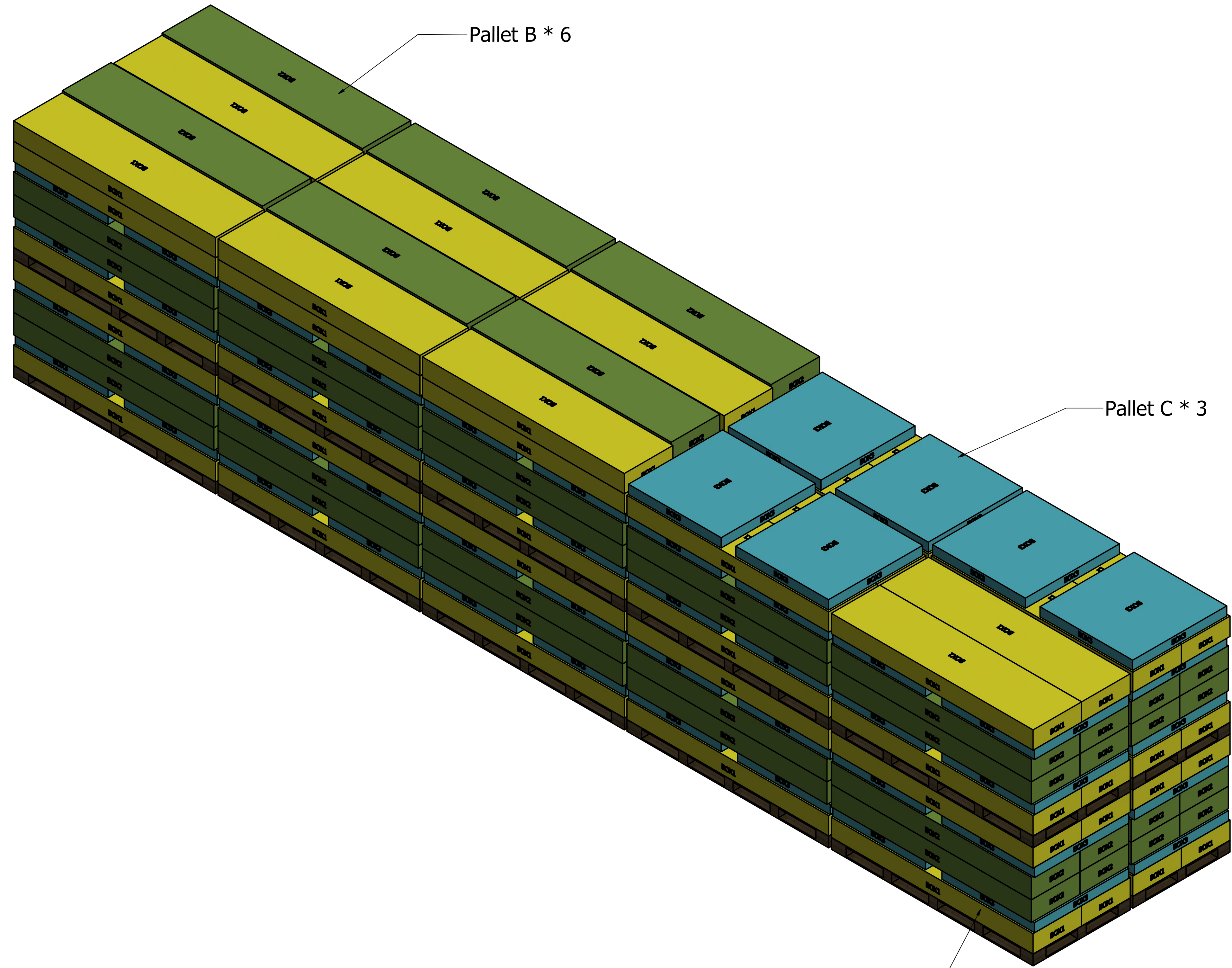

Pallet A (4 sets) \* 11  
Pallet B (4 sets+BOX1\*1+BOX2\*1) \* 6  
Pallet C (4 sets+BOX3\*2) \* 3

Pallet A \* 11

Pallet B \* 6

Pallet C \* 3

DRAWN Rudy		TITLE		
CHECKED				
QA				
MFG				
APPROVED		SIZE D	DWG NO	REV
		SCALE 1 / 20	SHEET 1 OF 1	

# Pallet A~C detail

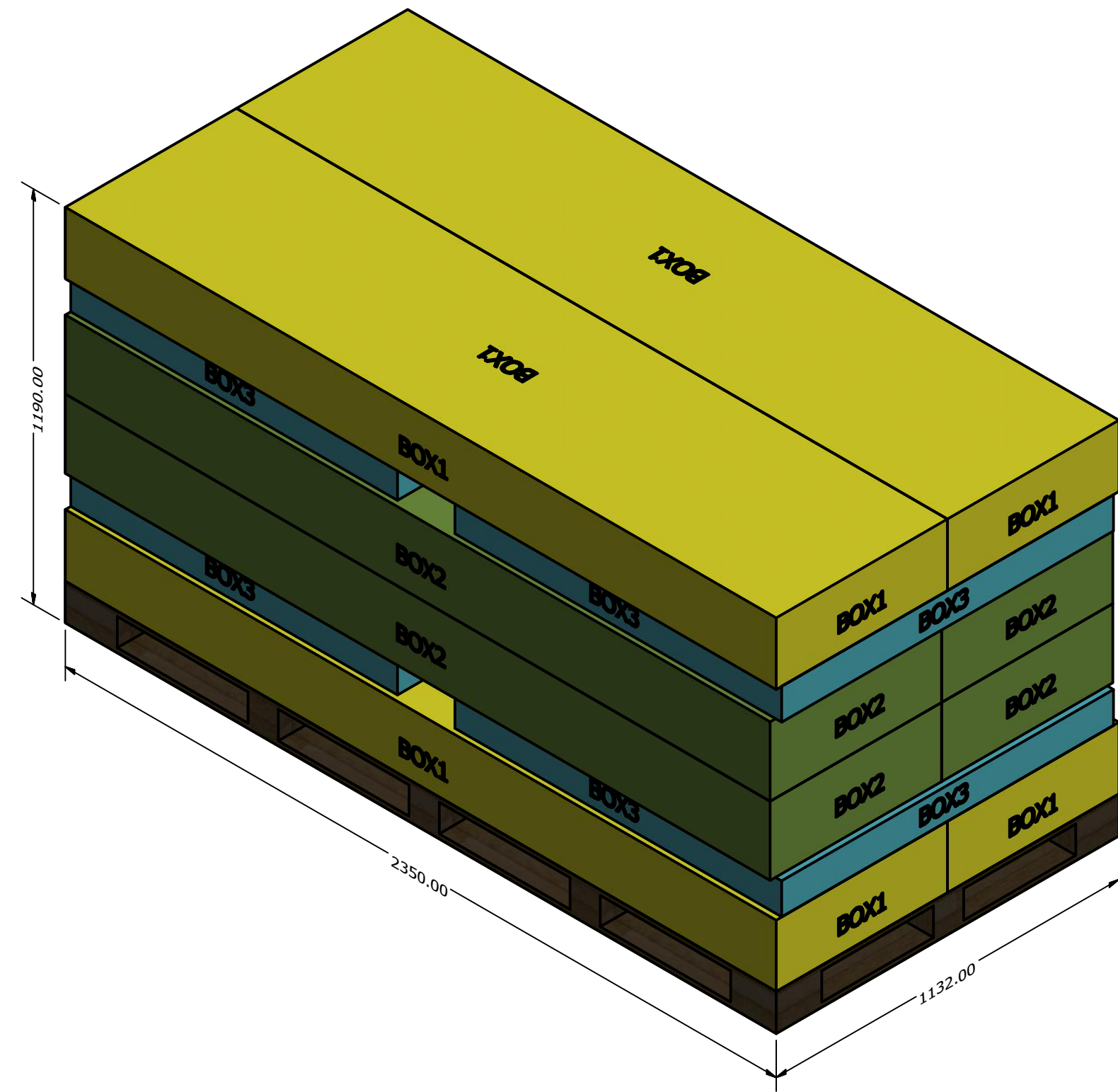

Pallet A ( 4 units)

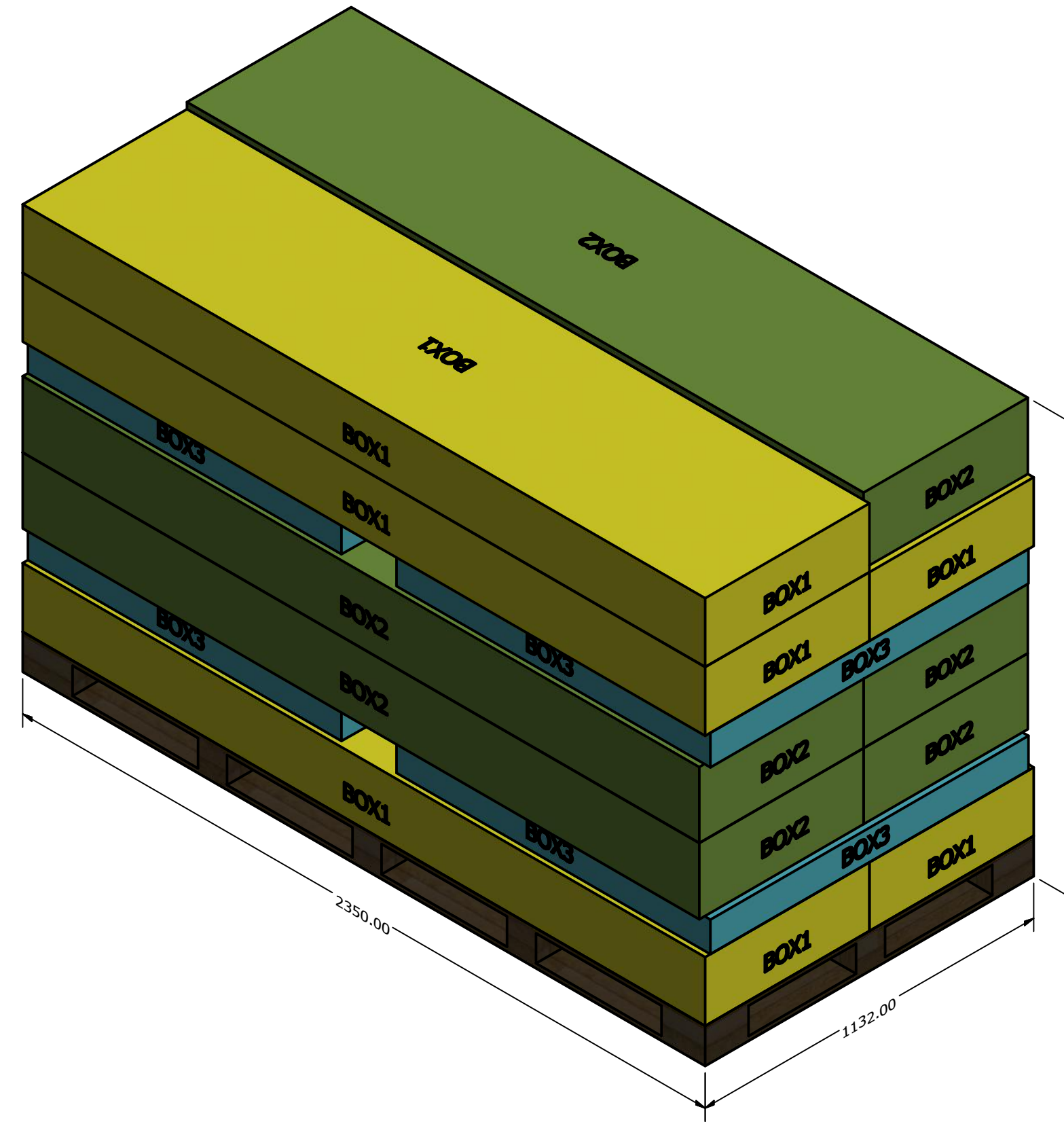

Pallet B ( 4 units+BOX1\*1+BOX2\*1)

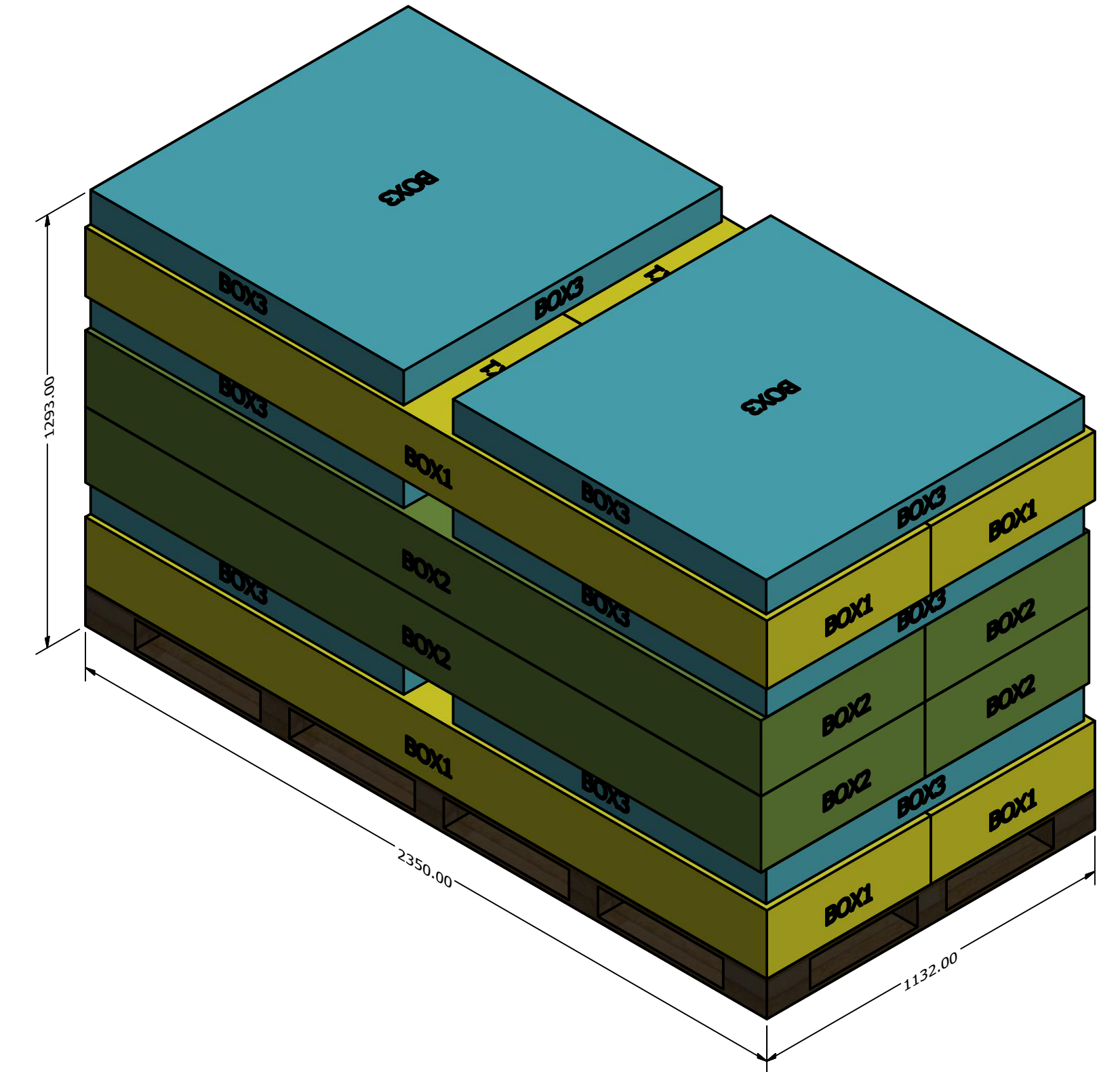

Pallet C ( 4 units + BOX3 \*2)

DRAWN	2019-12-16		
CHECKED		TITLE	
QA			
MFG			
APPROVED			
		SIZE	DWG NO
		D	Pallet A
		SCALE	REV
		0.08 : 1	SHEET 1 OF 1

BOX1

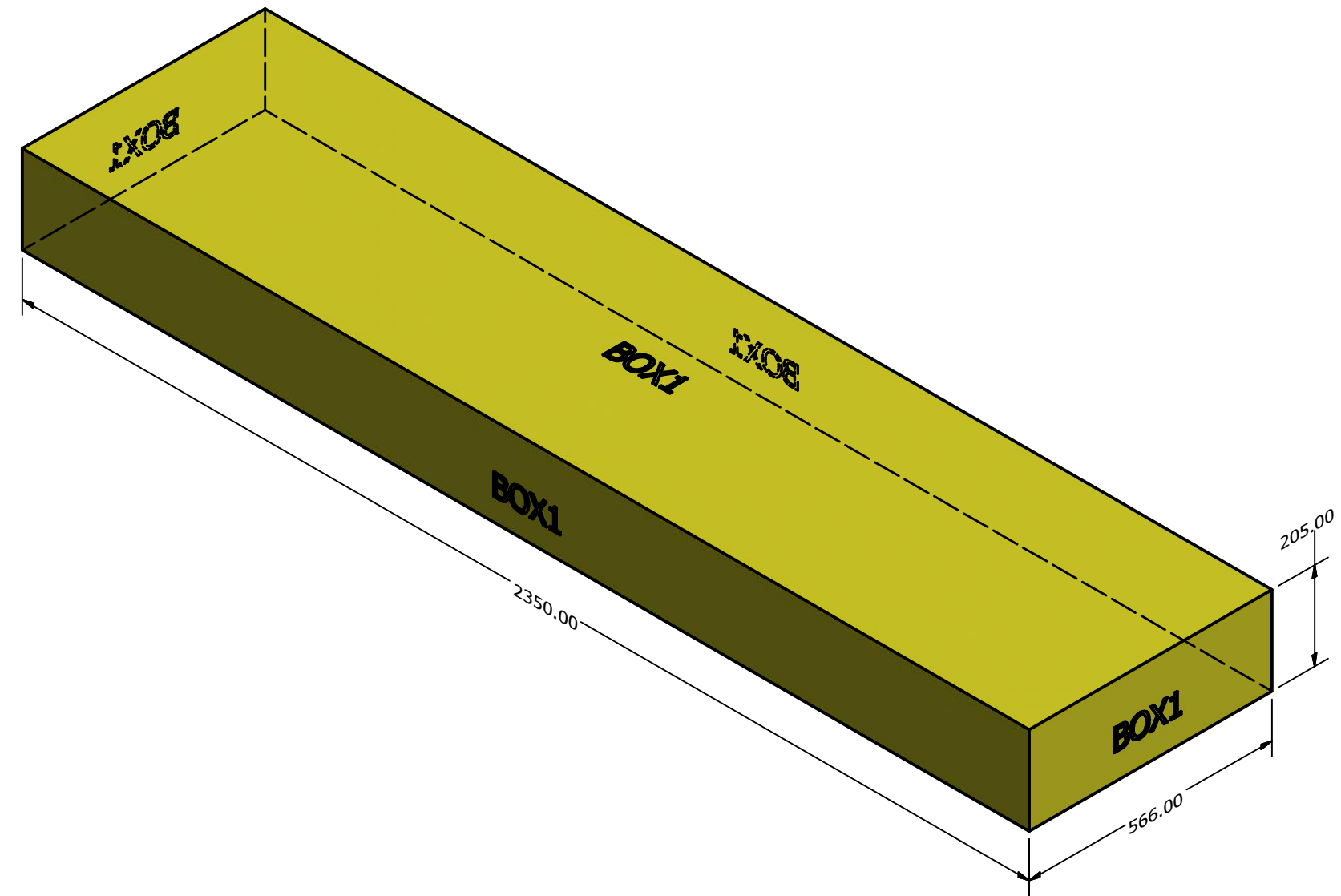

79kg

BOX2

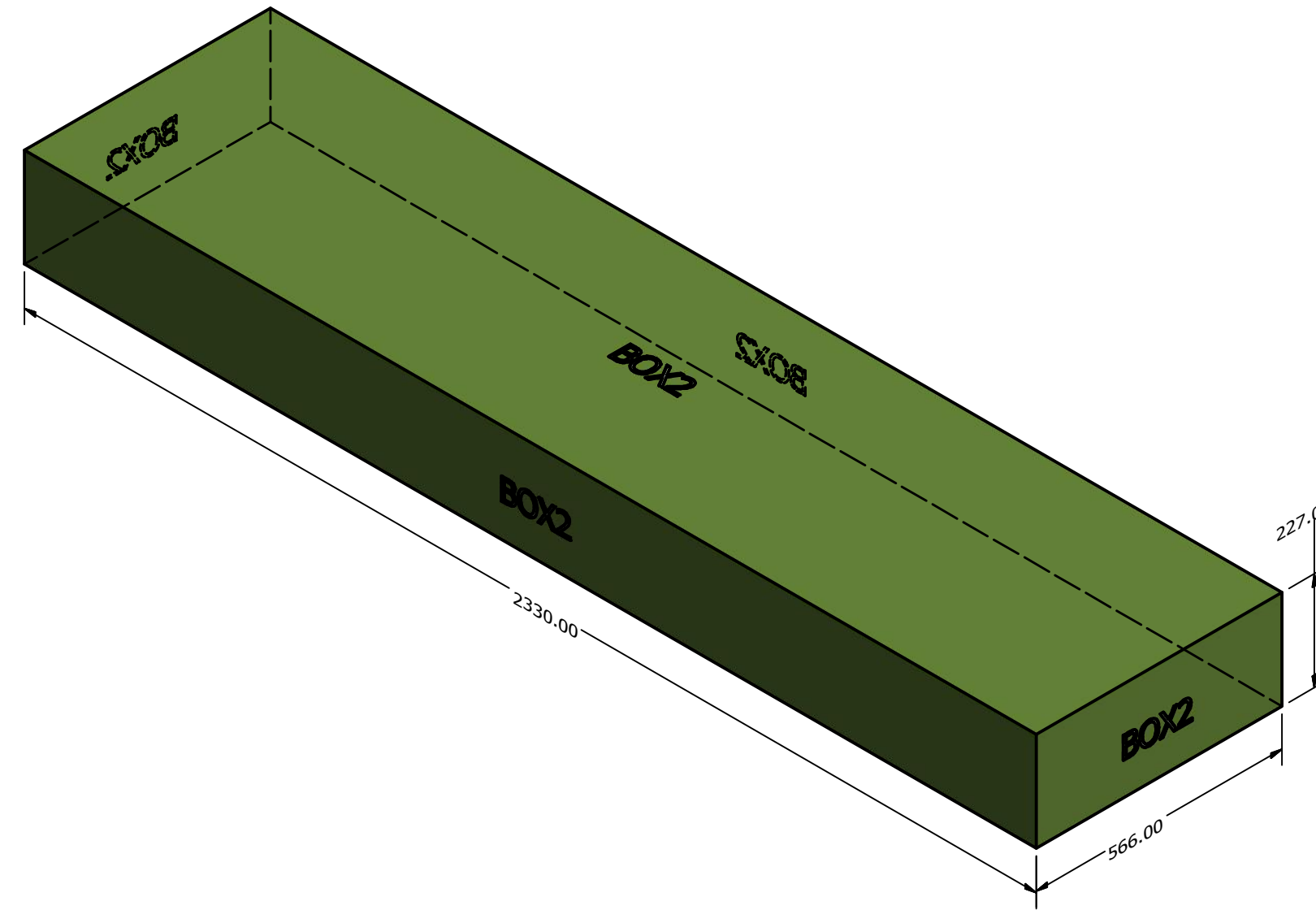

82kg

BOX3

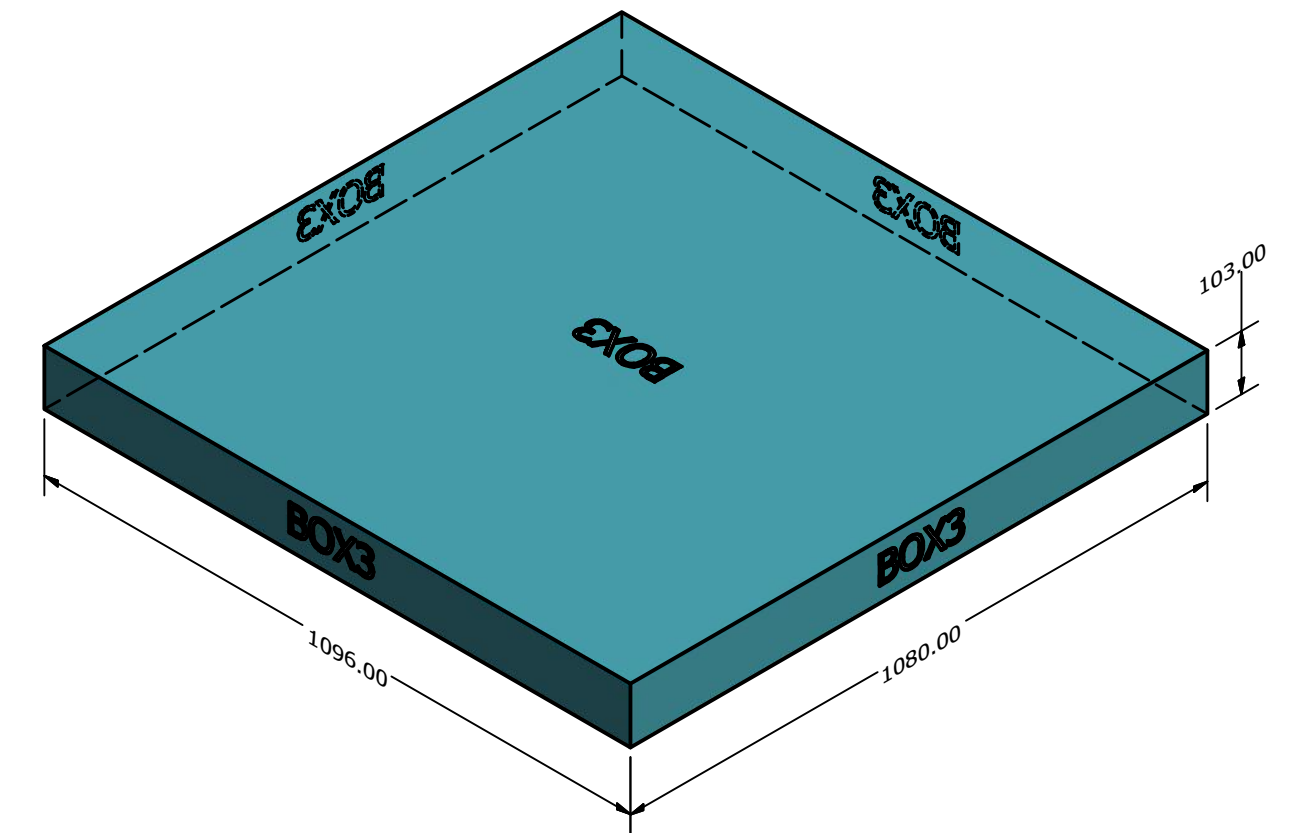

33kg

DRAWN Rudy		TITLE		
CHECKED				
QA				
MFG				
APPROVED		SIZE D	DWG NO BOXES	REV
		SCALE 0.10	SHEET 1 OF 1	