



MANUFACTURED BY:
Backyard Discovery
3305 Airport Drive, Pittsburg, KS 66762
800-856-4445

Basepoint Business Centre: Rivermead Drive, Westlea, Swindon SN5 7EX Phone: 0800-118-2476
J.P. Coenstraat 7, The Bridge, The Hague, 2595 WP, Netherlands Phone: 0800-567-8990

CANYON CREEK - WHITE

Swing Set Model # 2300347

The assembly manual must be retained
since it contains important information



WARNING

Adult Assembly Required.

Not suitable for children under 36 months due to small parts.
FOR DOMESTIC USE ONLY. INTENDED FOR OUTDOOR USE.



Please visit www.backyarddiscovery.com

For the most up to date assembly manual, to register your set, or to order replacement parts

Para obtener instrucciones en español, visite www.backyarddiscovery.com



**EASY STEP-BY-STEP
3D INTERACTIVE INSTRUCTIONS**

DOWNLOAD THE FREE APP



Owner's Manual - Basic Setup Dimensions & Assembly Notes

Place the set on level ground, not less than 6'-7" [2 m] from any structure or obstruction such as a fence, garage, house, overhanging branches, laundry lines, or electrical wires.

- While assembling unit, take time before and after each phase to make sure fort is level. If fort is not level, assembly will be difficult and improper assembly may result. Extra care must be taken to insure the fort is square.
- The safe play area refers to a zone extending 6'-7" (2 m) beyond the play product on all sides, including the space above the play product.

SAFE PLAY AREA DIAGRAM

Ground Dimensions

13'-4 1/4" [4.1 m] x 16'-4 1/4" [5.0 m]

Safe Play Area

26'-6 1/4" [8.1 m] x 29'-6 1/4" [9.0 m] x 16'-6 1/4" [5.0 m]

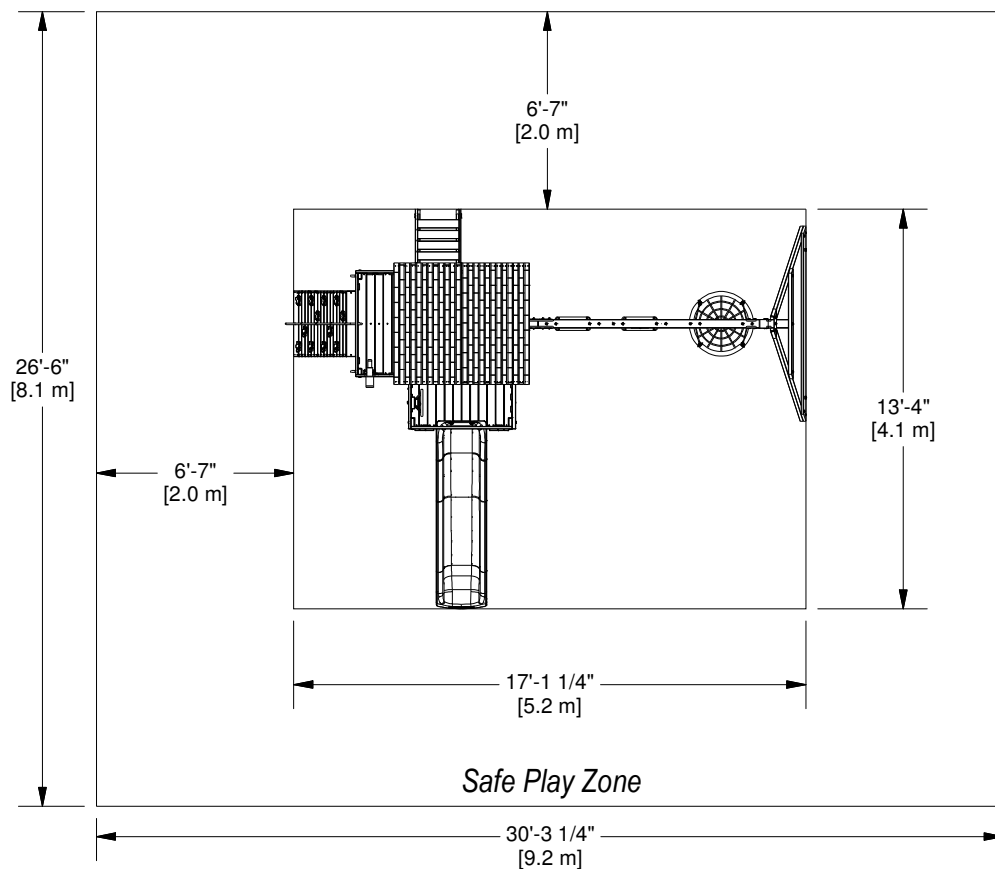

SAFE PLAY HEIGHT: 16'-6 1/4" [5.0 m]
MAXIMUM FALL HEIGHT: 6'-4 1/2" [1.9 m]

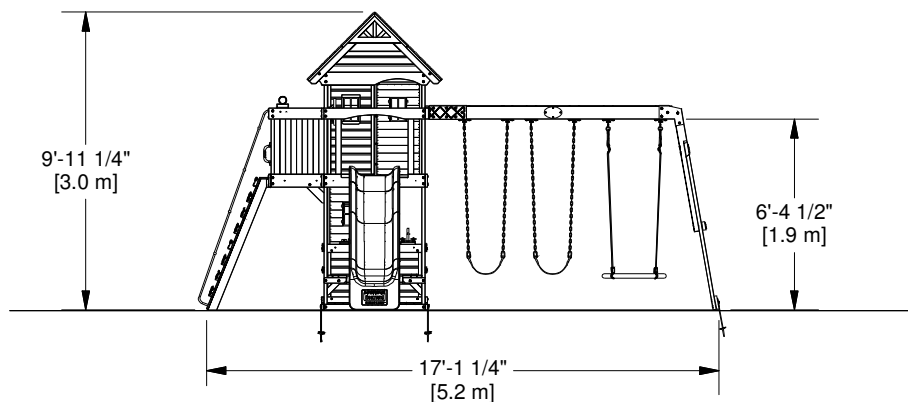

General Information:

Your set has been designed and engineered for children only and for residential use only.
A maximum of 150 lbs. per child is recommended for play activities designed for individual use.
A maximum of 120 lbs. per child is recommended for play activities designed for multiple child use.
A maximum of 9 children is recommended for this swing set.

Owner's Manual - Parts Identification

Wood Components (Not to Scale)



A1 SWING BEAM EXTENDED - W4L18499
(x1) 3 3/8"x5 1/4"x89 1/2" (86x134x2274)



A2 SB 9" BLOCK - W4L19017
(x1) 3 3/8"x5 1/4"x9" (86x134x228)

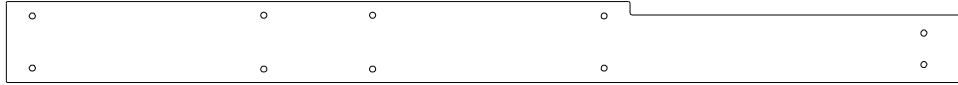

D1 SWING BEAM MOUNT - W4L19015
(x1) 1 3/8"x5 1/4"x62 3/8" (36x134x1585)



E1 DECK BRACE - W4L17821
(x4) 1 3/8"x3 3/8"x12 1/4" (36x86x311)



E2 LEFT REAR UPRIGHT - W4L17823
(x1) 1 3/8"x3 3/8"x51 3/4" (36x86x1314)



E3 LEFT FRONT UPRIGHT - W4L17824
(x1) 1 3/8"x3 3/8"x51 3/4" (36x86x1314)

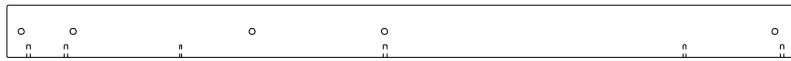

E4 RIGHT FRONT UPRIGHT - W4L17825
(x1) 1 3/8"x3 3/8"x51 3/4" (36x86x1314)

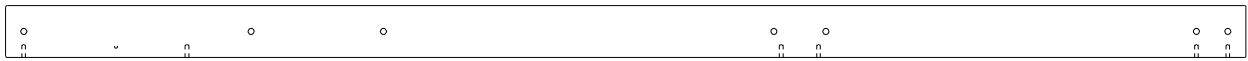

E5 RIGHT FRONT BALCONY UPRIGHT - W4L17826
(x1) 1 3/8"x3 3/8"x80 3/4" (36x86x2052)



E6 LEFT REAR UPRIGHT - W4L19001
(x1) 1 3/8"x3 3/8"x43 1/2" (36x86x1104)



E7 RIGHT REAR UPRIGHT - W4L17831
(x1) 1 3/8"x3 3/8"x43 1/2" (36x86x1104)

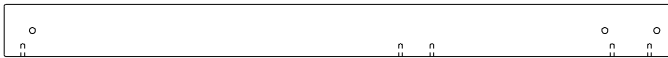

E8 LEFT FRONT UPRIGHT - W4L19002
(x1) 1 3/8"x3 3/8"x43 1/2" (36x86x1104)



E9 RIGHT FRONT UPRIGHT - W4L17833
(x1) 1 3/8"x3 3/8"x43 1/2" (36x86x1104)



E10 MOUNTING BLOCK - W4L17815
(x1) 1 3/8"x3"x4 3/4" (36x76x120)



E11 RIGHT FRONT BALCONY UPRIGHT - W4L17827
(x1) 1 3/8"x3 3/8"x80 3/4" (36x86x2052)



E12 MOUNTING BLOCK - W4L17816
(x1) 1 3/8"x3"x4 3/4" (36x76x120)



E72 RAIL - W4L17808
(x2) 1 3/8"x3 3/8"x57 3/8" (36x86x1457)

Owner's Manual - Parts Identification

Wood Components (Not to Scale)

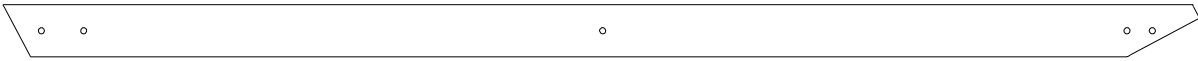

E77 ANGLE BRACE - W4L18495
(x2) 1 3/8"x3 3/8"x78" (36x86x1980)



E79 END SUPPORT - W4L18496
(x1) 1 1/2"x3 1/2"x44" (36x86x1120)

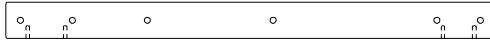

F1 RIGHT BALCONY UPRIGHT - W4L17806
(x1) 1 3/8"x2 3/8"x31 3/4" (36x60x805)

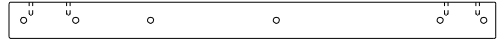

F2 LEFT BALCONY UPRIGHT - W4L17807
(x1) 1 3/8"x2 3/8"x31 3/4" (36x60x805)



F03 SUPPORT BLOCK - W4L18516
(x1) 1 3/8"x2 3/8"x9 1/4" (36x60x234)

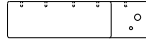

F04 SUPPORT BLOCK - W4L18517
(x1) 1 3/8"x2 3/8"x9 1/4" (36x60x234)

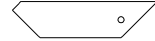

F5 ANGLE BRACE - W4L17822
(x2) 1 3/8"x2 3/8"x9 1/2" (36x60x240)



F06 FLOOR JOIST - W4L18510
(x1) 1 3/8"x2"x40 1/2" (36x50x1030)



G2 GROUND BOARD - W4L19003
(x1) 1"x5 1/4"x42 1/4" (24x134x1072)



G3 GROUND BOARD - W4L19004
(x1) 1"x5 1/4"x42 1/4" (24x134x1072)

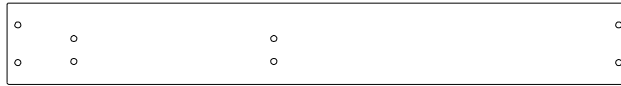

G4 GROUND BOARD - W4L19005
(x1) 1"x5 1/4"x40 1/2" (24x134x1030)



G5 RIGHT CENTER WALL RAIL - W4L19006
(x1) 1"x5 1/4"x63 3/8" (24x134x1609)

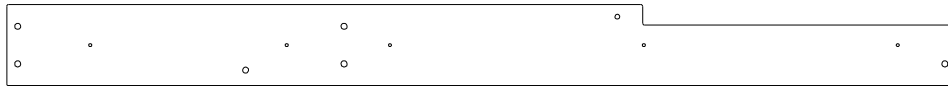

G6 FRONT CENTER WALL RAIL - W4L19014
(x1) 1"x5 1/4"x61 3/4" (24x134x1570)



G7 REAR CENTER WALL RAIL - W4L19007
(x1) 1"x5 1/4"x61 3/4" (24x134x1570)

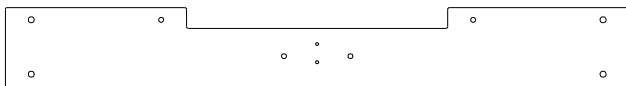

G8 LEFT CENTER WALL RAIL - W4L19000
(x1) 1"x5 1/4"x40 5/8" (24x134x1032)



G9 LEFT BALCONY WALL RAIL - W4L17648
(x1) 1"x5 1/4"x20 3/4" (24x134x528)

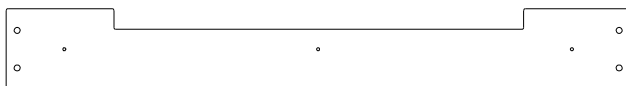

G10 FRONT BALCONY WALL RAIL - W4L17649
(x1) 1"x5 1/4"x40 5/8" (24x134x1032)

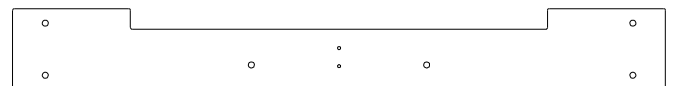

G11 LEFT SIDE WALL BOARD - W4L19008
(x1) 1"x5 1/4"x42 1/2" (24x134x1080)

Owner's Manual - Parts Identification

Wood Components (Not to Scale)



G12 GROUND BOARD - W4L18497
(x1) 1"x5 1/4"x78 1/8" (24x134x1984)

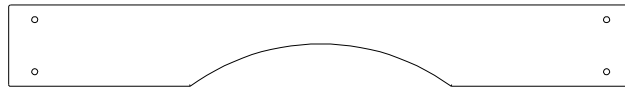

G13 ARCHED WALL RAIL - W4L19010
(x1) 1"x5 1/4"x40 5/8" (24x134x1032)



G14 ANGLED WALL RAIL - W4L19011
(x1) 1"x5 1/4"x45 3/4" (24x134x1162)

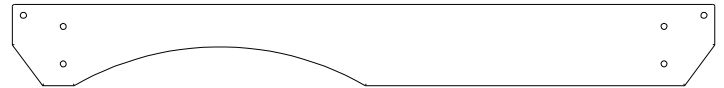

G15 ANGLED WALL RAIL - W4L19012
(x1) 1"x5 1/4"x45 3/4" (24x134x1162)

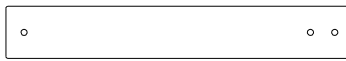

H1 TABLE SUPPORT - W4L11147
(x1) 1"x3 3/8"x22 3/8" (24x86x567)

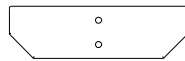

H2 TABLE SUPPORT - W4L18018
(x1) 1"x3 3/8"x11 5/8" (24x86x295)

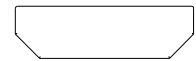

H3 TABLE SUPPORT - W4L18021
(x1) 1"x3 3/8"x11 5/8" (24x86x295)



H5 ATTACHMENT BOARD - W4L17639
(x1) 1"x3 3/8"x18 1/4" (24x86x465)



H6 BENCH BOARD - W4L18518
(x2) 1"x3 3/8"x23" (24x86x583)

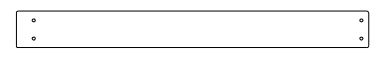

H7 BENCH BOARD - W4L18519
(x2) 1"x2 3/8"x23" (24x60x583)



H8 BENCH BOARD - W4L18520
(x2) 1"x3 3/8"x23" (24x86x583)



H9 ATTACHMENT BOARD - W4L17814
(x1) 1"x3 3/8"x26 1/4" (24x86x667)



H76 LADDER RUNG - W4L18505
(x4) 1"x3 3/8"x17 1/4" (24x86x437)



H77 LEFT UPRIGHT - W4L11173
(x1) 1"x3 3/8"x58" (24x86x1474)



H78 RIGHT UPRIGHT - W4L11174
(x1) 1"x3 3/8"x58" (24x86x1474)



J1 PORCH GROUND BOARD - W4L11128
(x1) 1"x2 3/8"x40 1/2" (24x60x1030)



J2 PORCH GROUND BOARD - W4L11129
(x1) 1"x2 3/8"x40 5/8" (24x60x1032)

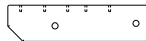

J3 BENCH SUPPORT - W4L18017
(x2) 1"x2 3/8"x9" (24x60x230)



J5 SUPPORT BLOCK - W4L18022
(x2) 1"x2 3/8"x2 7/8" (24x60x72)

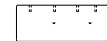

J6 SUPPORT BLOCK - W4L17817
(x1) 1"x2 3/8"x6 1/4" (24x60x160)



J7 SUPPORT BLOCK - W4L11158
(x1) 1"x2 3/8"x3 3/8" (24x60x86)



J09 FLOOR JOIST - W4L18527
(x1) 1"x2 3/8"x20 1/4" (24x60x515)



J10 PORCH GROUND BOARD - W4L17650
(x2) 1"x2 3/8"x21 1/8" (24x60x537)

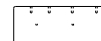

J11 SUPPORT BLOCK - W4L17818
(x1) 1"x2 3/8"x6 1/4" (24x60x160)



K01 ROCK WALL BOARD - W4L18503
(x1) 5/8"x5 1/4"x26 1/4" (16x134x667)

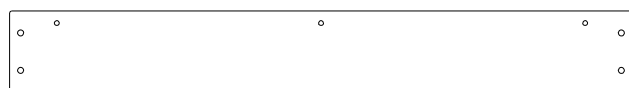

K4 GROUND BOARD - W4L19009
(x1) 5/8"x5 1/4"x40 1/2" (16x134x1030)

Owner's Manual - Parts Identification

Wood Components (Not to Scale)



K12 ARCHED WALL RAIL - W4L11143
(x1) 5/8"x5 1/4"x40 5/8" (16x134x1032)



K16 TABLE BOARD - W4L18530
(x1) 5/8"x5 1/4"x23" (16x134x583)



K17 FLOOR BOARD - W4L18523
(x2) 5/8"x5 1/4"x21 1/8" (16x134x537)



L05 FLOOR BOARD - W4L18524
(x1) 5/8"x4 1/8"x19 1/4" (16x104x488)



M1 WALL RAIL - W4L19013
(x1) 5/8"x3 3/8"x40 1/2" (16x86x1030)



M03 BENCH BOARD - W4L18529
(x2) 5/8"x3 3/8"x23" (16x86x583)



M04 FLOOR BOARD - W4L18506
(x8) 5/8"x3 3/8"x21 1/8" (16x86x537)

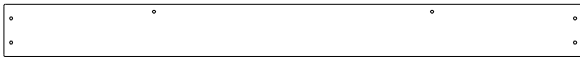

M06 COUNTER TOP - W4L18511
(x1) 5/8"x3 3/8"x37 5/8" (16x86x957)

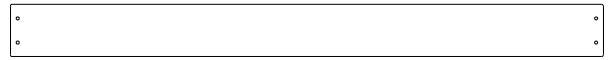

M07 COUNTER TOP - W4L18512
(x2) 5/8"x3 3/8"x38 5/8" (16x86x981)



M08 FLOOR BOARD - W4L18526
(x1) 5/8"x3 1/4"x19 7/8" (16x82x504)



M09 FLOOR BOARD - W4L18521
(x10) 5/8"x3 3/8"x19 7/8" (16x86x504)

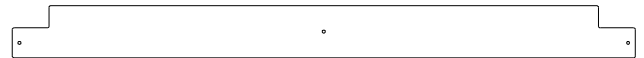

M10 FLOOR BOARD - W4L18513
(x1) 5/8"x3 3/8"x40 5/8" (16x86x1031)

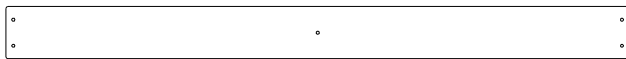

M11 FLOOR BOARD - W4L18522
(x15) 5/8"x3 3/8"x40 5/8" (16x86x1031)

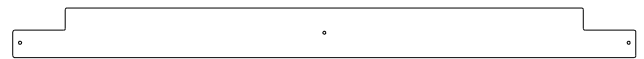

M12 FLOOR BOARD - W4L18528
(x2) 5/8"x3 1/4"x40 5/8" (16x82x1031)

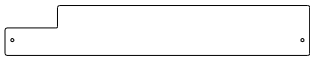

M13 FLOOR BOARD - W4L18525
(x1) 5/8"x3 1/4"x19 7/8" (16x82x504)

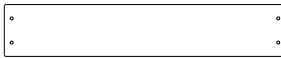

M73 REAR SUPPORT - W4L18504
(x1) 5/8"x3 3/8"x18 1/4" (16x86x465)

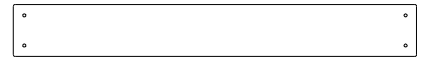

M74 ROCK WALL BOARD - W4L18500
(x7) 5/8"x3 3/8"x26 1/4" (16x86x667)



M75 ROCK WALL BOARD - W4L18501
(x4) 5/8"x3 3/8"x26 1/4" (16x86x667)



M76 ROCK WALL BOARD - W4L18502
(x4) 5/8"x3 3/8"x26 1/4" (16x86x667)

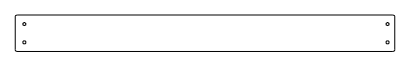

N02 PICKET - W4L18514
(x18) 5/8"x2 3/8"x24 3/4" (16x60x628)

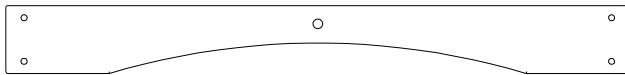

Q1 ARCHED WALL RAIL - W4L11142
(x1) 1"x4 3/8"x40 5/8" (24x112x1032)

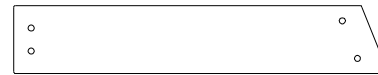

Q2 GROUND BOARD - W4L17640
(x2) 1"x4 3/8"x24 3/8" (24x112x620)

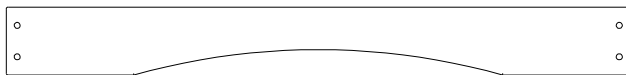

Q3 ARCHED WALL RAIL - W4L17653
(x1) 1"x4 3/8"x40 5/8" (24x112x1032)



Q4 WALL RAIL - W4L17654
(x1) 1"x4 3/8"x23 5/8" (24x112x600)

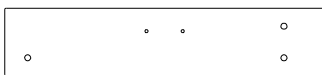

Q5 WALL RAIL - W4L17655
(x1) 1"x4 3/8"x20 7/8" (24x112x529)



Q6 ARCHED WALL RAIL - W4L19016
(x1) 1"x4 3/8"x43 7/8" (24x112x1113)

Owner's Manual - Parts Identification

Wood Components (Not to Scale)



SP71 SWING BEAM SUPPORT - W4L18498
(x1) 3 3/8"x3 3/8"x49 1/2" (86x86x1256)



T01 SUPPORT BOARD - W4L18507
(x3) 1"x1 3/8"x37 5/8" (24x34x957)

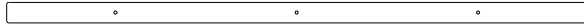

T02 SUPPORT BOARD - W4L18508
(x1) 1"x1 3/8"x37 3/4" (24x34x959)

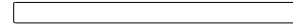

T03 SUPPORT BOARD - W4L18509
(x2) 1"x1 3/8"x18 3/4" (24x34x477)



T04 SUPPORT BOARD - W4L18515
(x1) 1"x1 3/8"x37 3/4" (24x34x958)



Y1 TOP BOARD - W4L17809
(x1) 5/8"x3 3/4"x26 1/4" (16x94x667)



E13 RIGHT REAR UPRIGHT ASSEMBLY - W2A03847
(x1) 1 3/8"x3 3/8"x51 3/4" (36x86x1314)

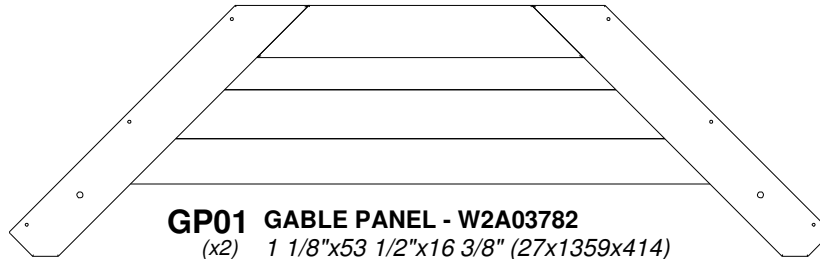

GP01 GABLE PANEL - W2A03782
(x2) 1 1/8"x53 1/2"x16 3/8" (27x1359x414)

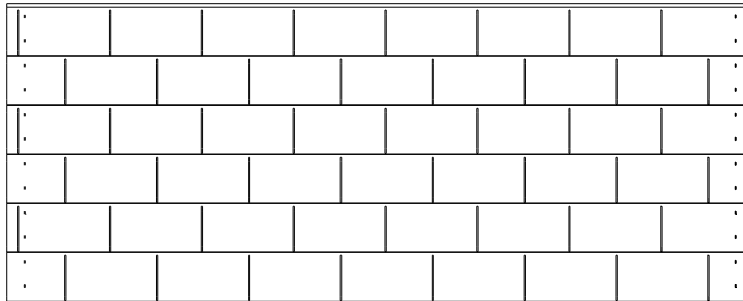

RP1 LOWER ROOF PANEL - W2A04024
(x2) 1 3/8"x19 3/8"x48 5/8" (35x491x1236)

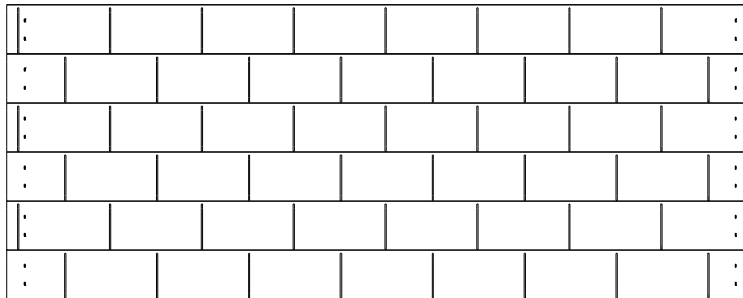

RP2 TOP ROOF PANEL - W2A04025
(x2) 1 3/8"x19 1/8"x48 5/8" (35x486x1236)

Owner's Manual - Parts Identification

Wood Components (Not to Scale)

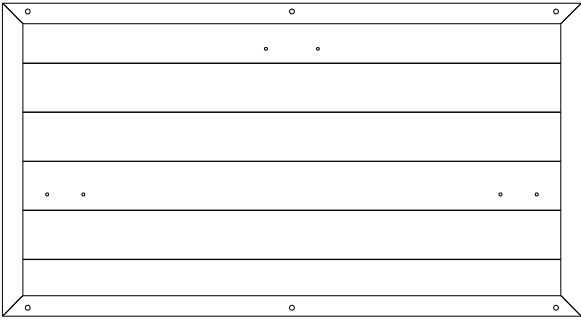

WP01 WALL PANEL - W2A03778
(x1) 1"x20 3/8"x37 3/4" (24x517x958)

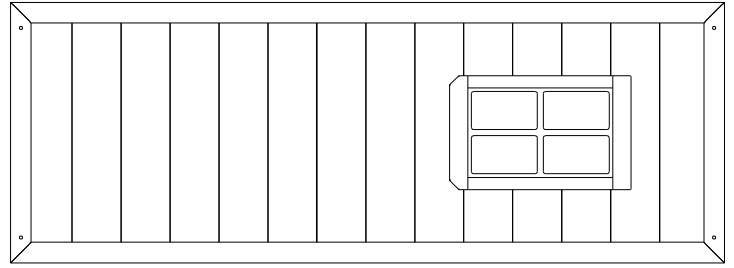

WP02 WALL PANEL - W2A03779
(x1) 1"x16 7/8"x46 1/2" (24x430x1181)

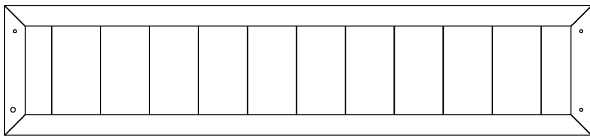

WP03 WALL PANEL - W2A03786
(x1) 1"x18 7/8"x11 3/4" (24x214x971)

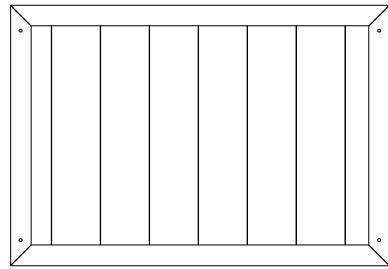

WP04 WALL PANEL - W2A03784
(x2) 1"x16 7/8"x24 5/8" (24x430x627)

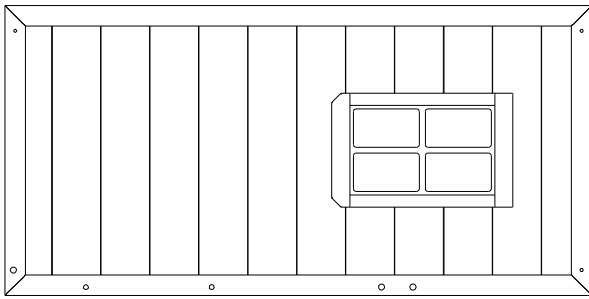

WP05 WALL PANEL - W2A03785
(x1) 1"x16 7/8"x46 1/2" (24x479x971)

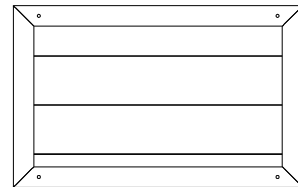

WP06 WALL PANEL - W2A03780
(x1) 1"x18 7/8"x11 3/4" (24x479x300)

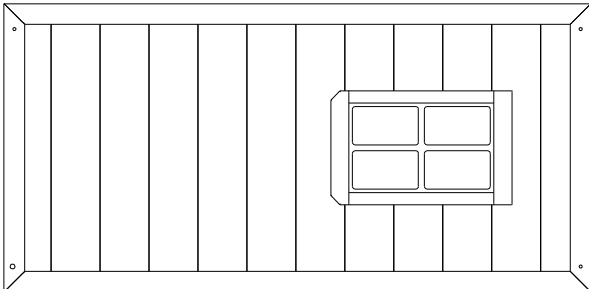

WP07 WALL PANEL - W2A03783
(x1) 1"x16 7/8"x46 1/2" (24x476x971)

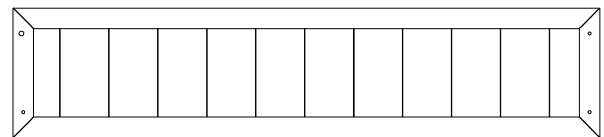

WP08 WALL PANEL - W2A03787
(x1) 1"x18 7/8"x11 3/4" (24x214x971)

Owner's Manual - Parts Identification

Wood Components (Not to Scale)

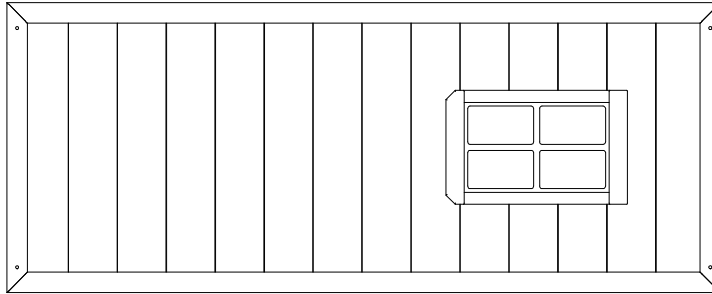

WP09 WALL PANEL - W2A03781
(x1) 1"x16 7/8"x46 1/2" (24x479x1181)

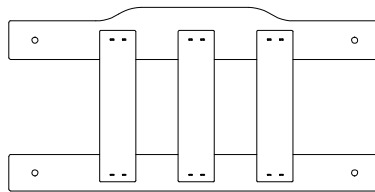

WP10 BENCH BACK ASSEMBLY - W2A03777
(x2) 1 1/8"x11 7/8"x24 1/4" (27x303x615)

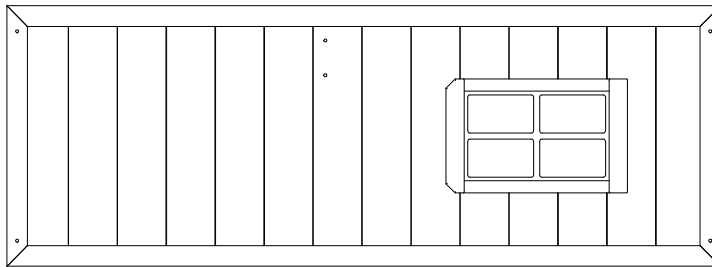

WP11 WALL PANEL - W2A03788
(x1) 1"x16 7/8"x46 1/2" (24x430x1181)

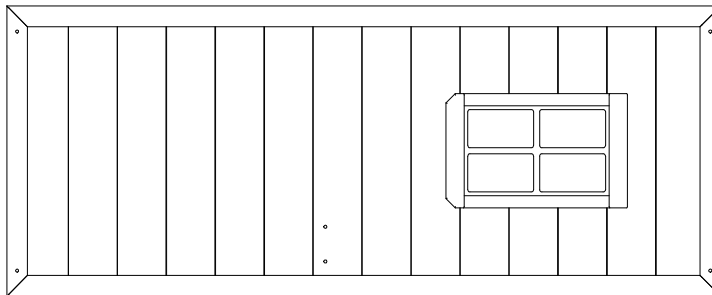

WP12 WALL PANEL - W2A03789
(x1) 1"x16 7/8"x46 1/2" (24x479x1181)

Owner's Manual - Parts Identification

Hardware Components

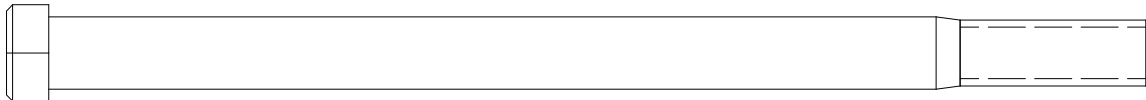

H101170 BOLT HEX BLK
(x12) 3/8x5 3/4



H100498 BOLT HEX - BLK
(x4) 5/16x1 1/2

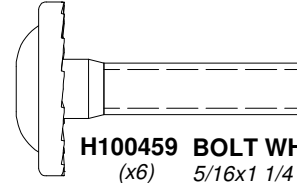

H100459 BOLT WH BLK
(x6) 5/16x1 1/4



H100480 BOLT WH BLK
(x2) 5/16x4 3/4

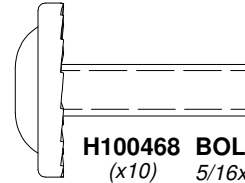

H100468 BOLT WH BLK
(x10) 5/16x1

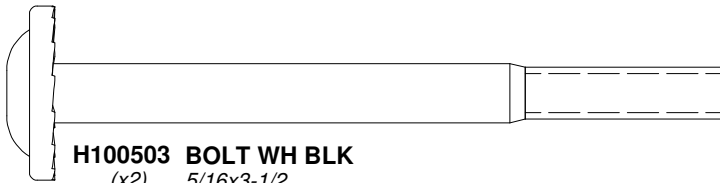

H100503 BOLT WH BLK
(x2) 5/16x3-1/2

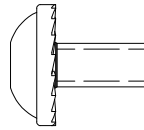

H100401 BOLT WH BLK
(x1) 1/4x1/2

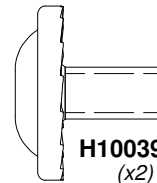

H100396 BOLT WH BLK
(x2) 5/16x1/2

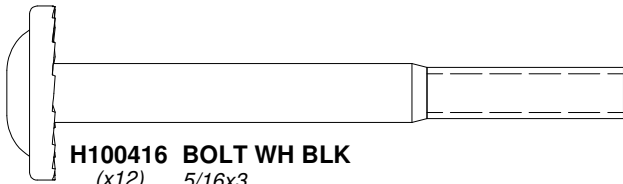

H100416 BOLT WH BLK
(x12) 5/16x3

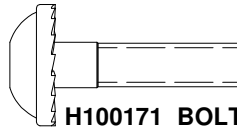

H100171 BOLT WH BLK
(x2) 1/4x1

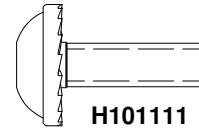

H101111 BOLT WH BLK
(x24) 1/4x3/4

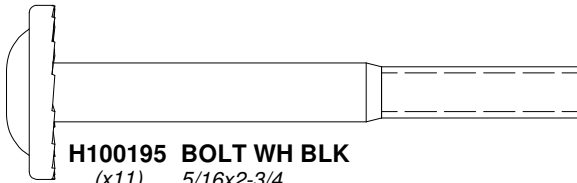

H100195 BOLT WH BLK
(x11) 5/16x2-3/4

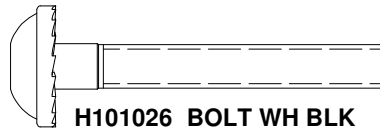

H101026 BOLT WH BLK
(x8) 1/4x1-3/4

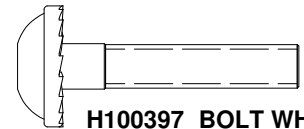

H100397 BOLT WH BLK
(x2) 1/4x1 1/4

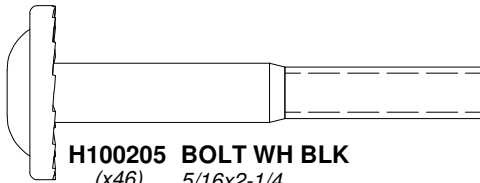

H100205 BOLT WH BLK
(x46) 5/16x2-1/4



**H100831 NUT BARREL PTH
BLK**
(x4) 1/4x3/4

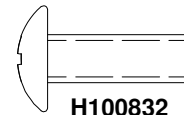

**H100832 BOLT PTH BLK
(with LOCTITE)**
(x4) 1/4x3/4

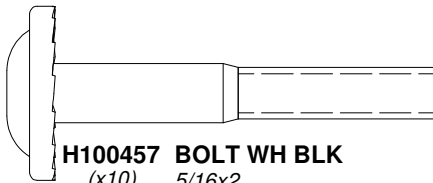

H100457 BOLT WH BLK
(x10) 5/16x2

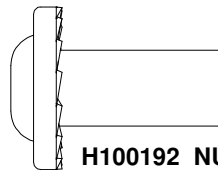

**H100192 NUT BARREL WH
BLK**
(x14) 5/16x7/8

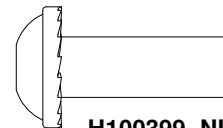

**H100399 NUT BARREL WH
BLK**
(x1) 1/4x7/8

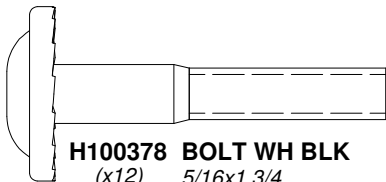

H100378 BOLT WH BLK
(x12) 5/16x1 3/4

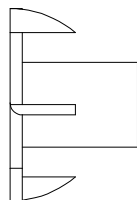

H101168 T-NUT BLK
(x12) 3/8

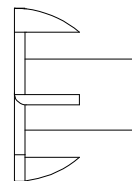

H100379 T-NUT BLK
(x111) 5/16

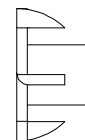

H100398 T-NUT BLK
(x42) 1/4

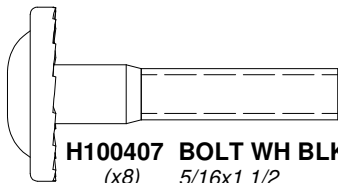

H100407 BOLT WH BLK
(x8) 5/16x1 1/2

Owner's Manual - Parts Identification

Hardware Components

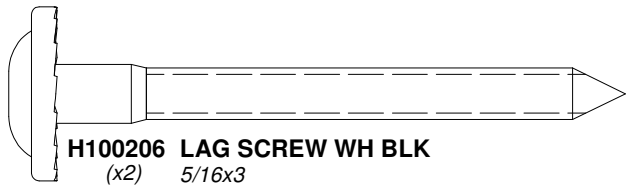

H100206 LAG SCREW WH BLK
(x2) 5/16x3

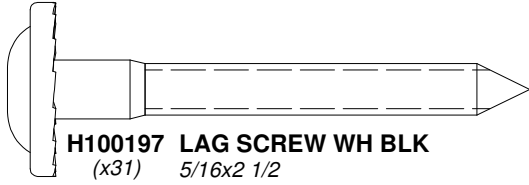

H100197 LAG SCREW WH BLK
(x31) 5/16x2 1/2

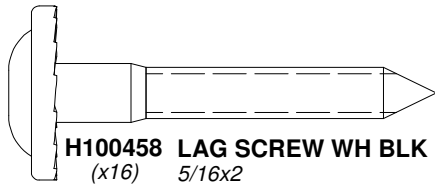

H100458 LAG SCREW WH BLK
(x16) 5/16x2

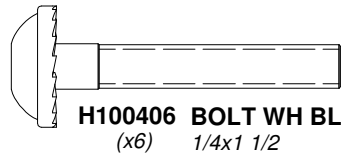

H100406 BOLT WH BLK
(x6) 1/4x1 1/2

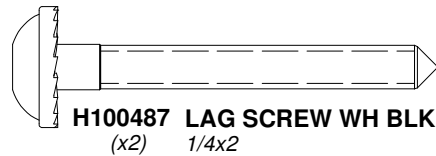

H100487 LAG SCREW WH BLK
(x2) 1/4x2

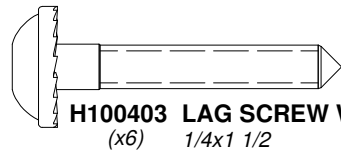

H100403 LAG SCREW WH BLK
(x6) 1/4x1 1/2

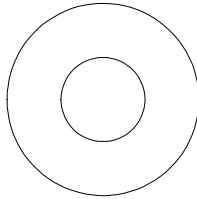

H101167 WASHER FLAT BLK
(x12) 11x25

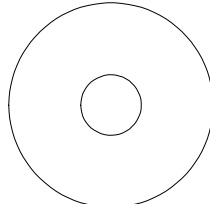

H100105 WASHER FLAT
(x3) 8x27

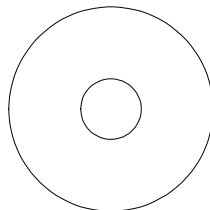

H100478 WASHER FLAT BLK
(x4) 8x27

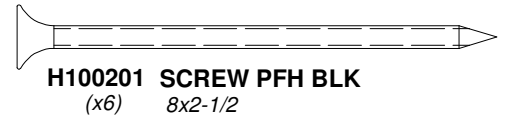

H100201 SCREW PFH BLK
(x6) 8x2-1/2

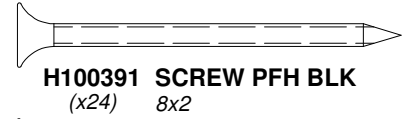

H100391 SCREW PFH BLK
(x24) 8x2

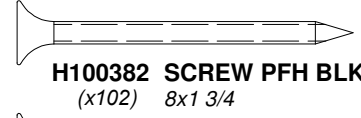

H100382 SCREW PFH BLK
(x102) 8x1 3/4

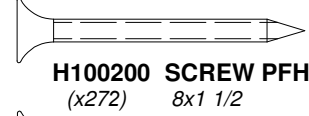

H100200 SCREW PFH BLK
(x272) 8x1 1/2

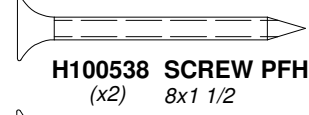

H100538 SCREW PFH SD
(x2) 8x1 1/2

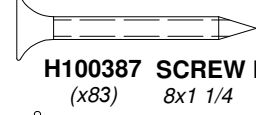

H100387 SCREW PFH BLK
(x83) 8x1 1/4

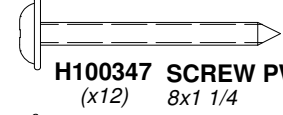

H100347 SCREW PWH WZ
(x12) 8x1 1/4

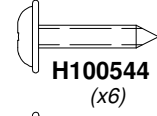

H100544 SCREW PWH SD
(x6) 8x5/8

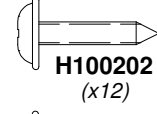

H100202 SCREW PWH BLK
(x12) 8x5/8

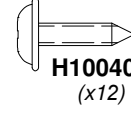

H100408 SCREW PWH BLK
(x12) 8x1/2

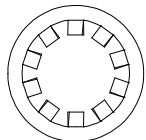

H101166 WASHER LOCK INT BLK
(x12) 10x18

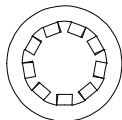

H100473 WASHER LOCK INT BLK
(x24) 8x15

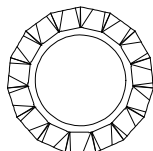

H100199 WASHER LOCK EXT BLK
(x2) 12x19

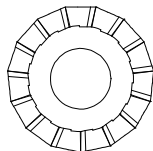

H100198 WASHER LOCK EXT BLK
(x132) 8x19

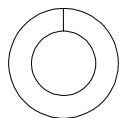

H100477 WASHER SPLIT BLK
(x4) 5/16

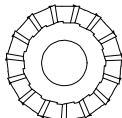

H100405 WASHER LOCK EXT BLK
(x24) 6x15

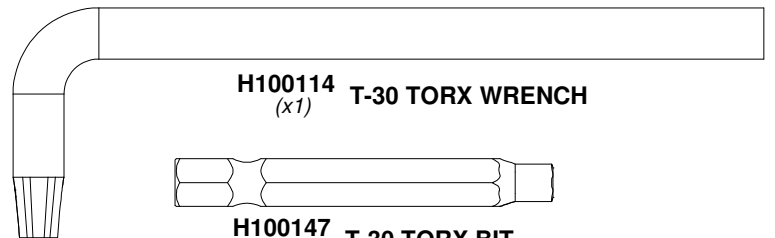

H100114 T-30 TORX WRENCH
(x1)



H100147 T-30 TORX BIT
(x1)

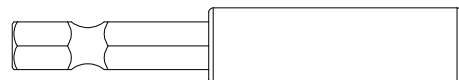

H101100 MAGNETIC DRIVER
(x1)

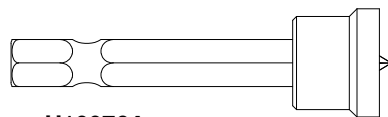

H100764 SCREW SETTER
(x1)

Owner's Manual - Parts Identification

Accessory Components (Not to Scale)

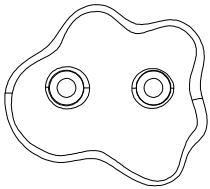

A6P00592 GREY HC ROCK
(x12) #1

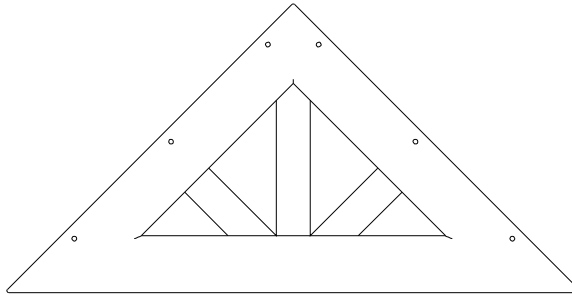

A6P00836 PLASTIC SUNBURST
(x2)

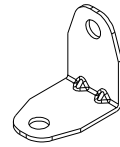

A4M01047 L BRACKET
(x2) 2.5x38x55x55

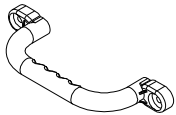

A6P00654 HAND GRIP
(x4) GREY PLASTIC

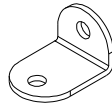

A4M00710 L BRACKET
(x2) BLACK 32x51

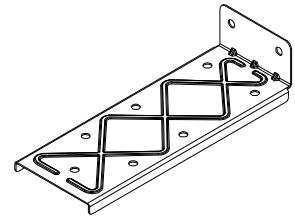

A4M01679 EXTENDED SWING BEAM BRACKET
(x2)

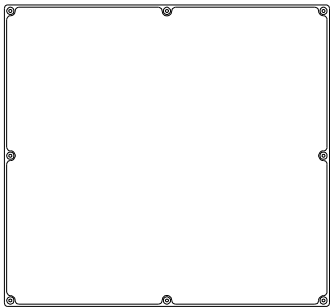

A6P00324 CHALK BOARD
(x1) LARGE

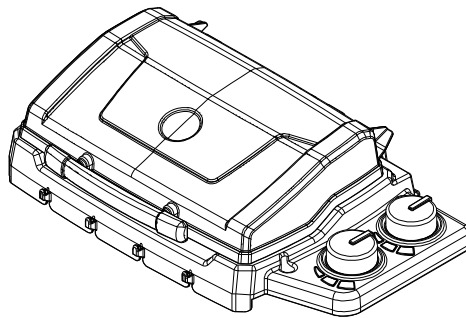

A6P00282 BBQ GRILL
(x1)

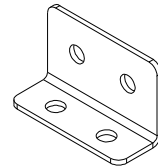

A4M00855 L BRACKET
(x2) 32x51x82

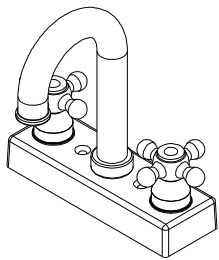

A6P00024 FAUCET KIT
(x1)



141154 GRILL FOOD SET
(x1)

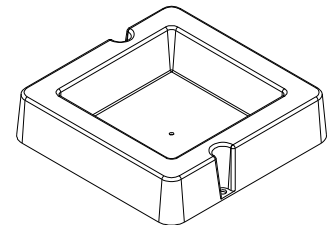

A6P00032 SURFACE MOUNT BASIN
(x1)

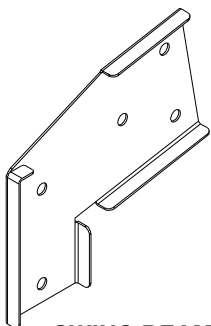

A4M00617 SWING BEAM EXTENSION BRACKET-LEFT
(x1)

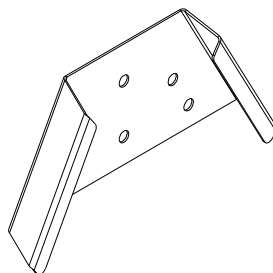

A4M01782 A-FRAME BRACKET
(x1)

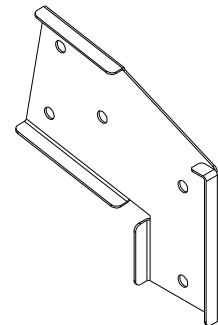

A4M00618 SWING BEAM EXTENSION BRACKET-RIGHT
(x1)

Owner's Manual - Parts Identification

Accessory Components (Not to Scale)

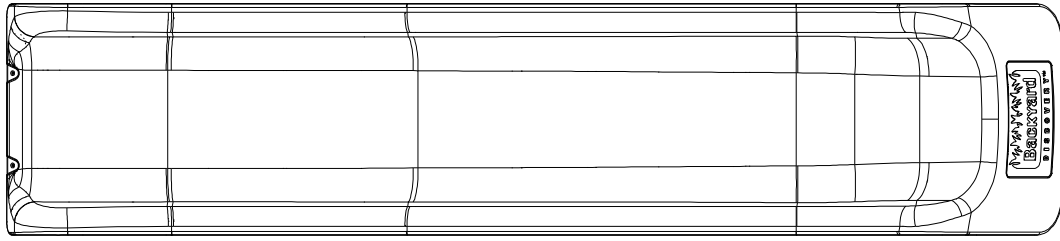

A6P00554
(x1) **8' BLOW MOLDED SLIDE - GREY**

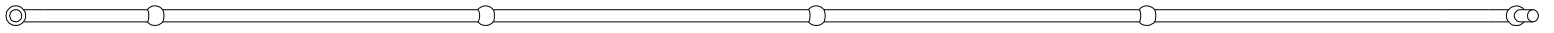

A6P00537
(x1) **CLIMBING ROPE**

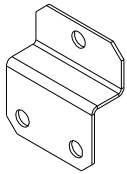

A4M02676
(x4) **BRACKET**

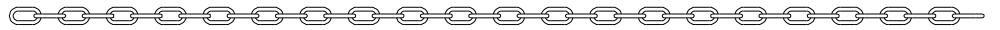

A4M02256
(x4) **CHAIN BLACK 51.25"**

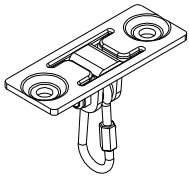

A4M02171
(x6) **SWING HANGER**

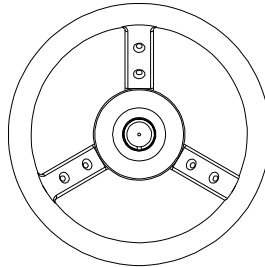

A6P00618
(x1) **STEERING WHEEL**



A4M01126
(x1) **26" WEB SWING**

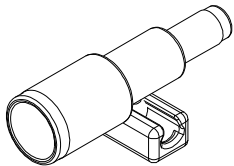

A6P00596
(x1) **TELESCOPE**



A6P00595
(x2) **SWING SEAT GREY 22"**



A100164
(x1) **BYD ID TAG
(LARGE) AGES
3-10**

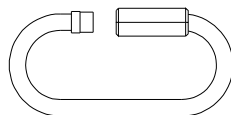

A4M00633
(x4) **QUICK LINK BLK**

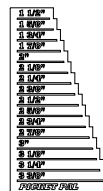

A6P00410
(x1) **PICKET PAL**

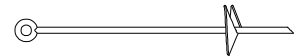

A4M02252
(x6) **AUGER GROUND
STAKE**

PRE-ASSEMBLY STEP 1 - SORTING PARTS

It is critical for ease of assembly that you take the time to sort and organize the wood and hardware.

WOOD PARTS:

- Organize wood parts by the three-digit, alpha-numeric number stamped on each board (ex. P01).
- If there are multiple boards with the same stamped number, stack those pieces together.
- Stamps can be found on the flat surface of the boards or on the end of the boards.
- Allow yourself plenty of room - the wood pieces can take up a significant amount of space.

NOTE: CARTONS ARE NOT ORGANIZED BY BOARD NUMBER.

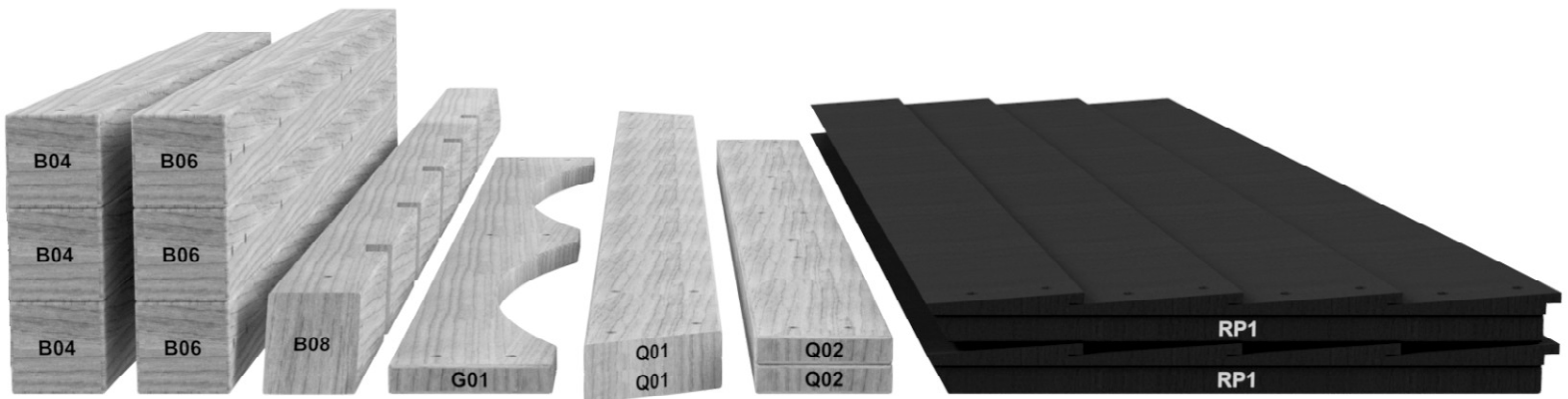

HARDWARE PARTS:

- We recommend that you have a separate table to organize the hardware.
- Hardware bags are printed with a seven-digit, alpha-numeric part number.
- You can organize your hardware by part number or group by hardware type (i.e. bolts, nuts, etc.).
- During assembly you only need to reference the last four digits of the number.

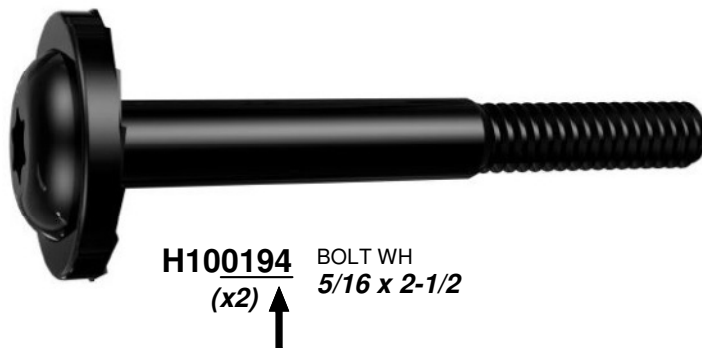

PRE-ASSEMBLY STEP 2 - TOOLS REQUIRED



Cordless Drill or
Electric Drill



Drill Attachments:
Phillips Head



1/8", 3/16", 3/8" & 7/16" Drill Bits



Open End Wrenches 1/2" & 9/16"



3/8" Drive Ratchet, 1/2" &
9/16" STD Sockets 1/2" & 9/16" Deep Sockets



Phillips Screw Driver



Claw Hammer



Rubber Mallet - Optional

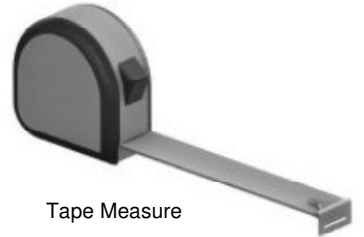

Tape Measure

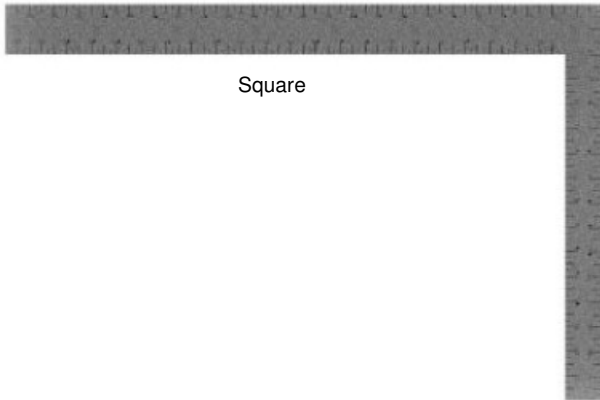

Square





Level 24"

PRE-ASSEMBLY STEP 3 - CHOOSE YOUR ASSEMBLY METHOD



There are several types of assembly instructions available to you.

1. Printed Assembly Manual included with your set
2. BILT APP - 3D interactive instructions
3. Combination of the Printed Manual and BILT APP (Note: Step numbers can differ between the two methods)

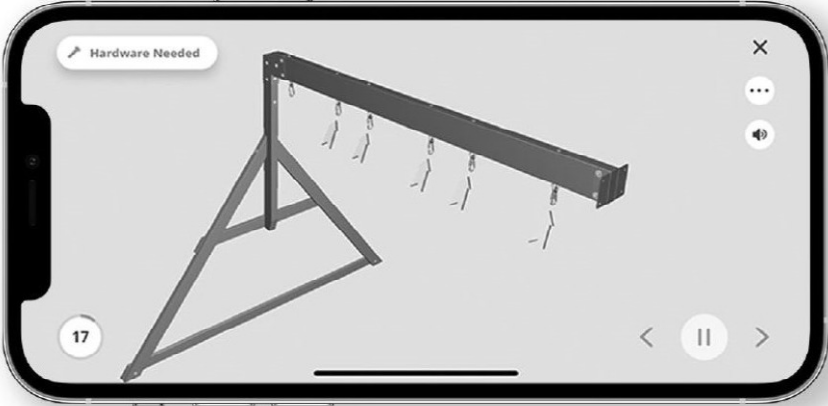

Scan for easy 3D instructions

Download the BILT app
before you begin



The image shows a smartphone screen displaying the BILT app interface. The screen features a 3D assembly diagram of a metal frame with a horizontal beam and several hanging components. The interface includes a 'Hardware Needed' button at the top left, a close button (X) at the top right, a menu button (three dots) and a volume icon below it, and a page number '17' in a circle at the bottom left. At the bottom center, there are navigation arrows and a pause button.

STEP 1 - LADDER ASSEMBLY

QTY	PART NUMBER	DESCRIPTION
8	H100391	SCREW PFH 8x2 BLK



H77 LEFT UPRIGHT - W4L11173
(x1) 1"x3 3/8"x58" (24x86x1474)



H76 LADDER RUNG - W4L18505
(x4) 1"x3 3/8"x17 1/4" (24x86x437)

TIP:
ALIGN PILOT HOLES

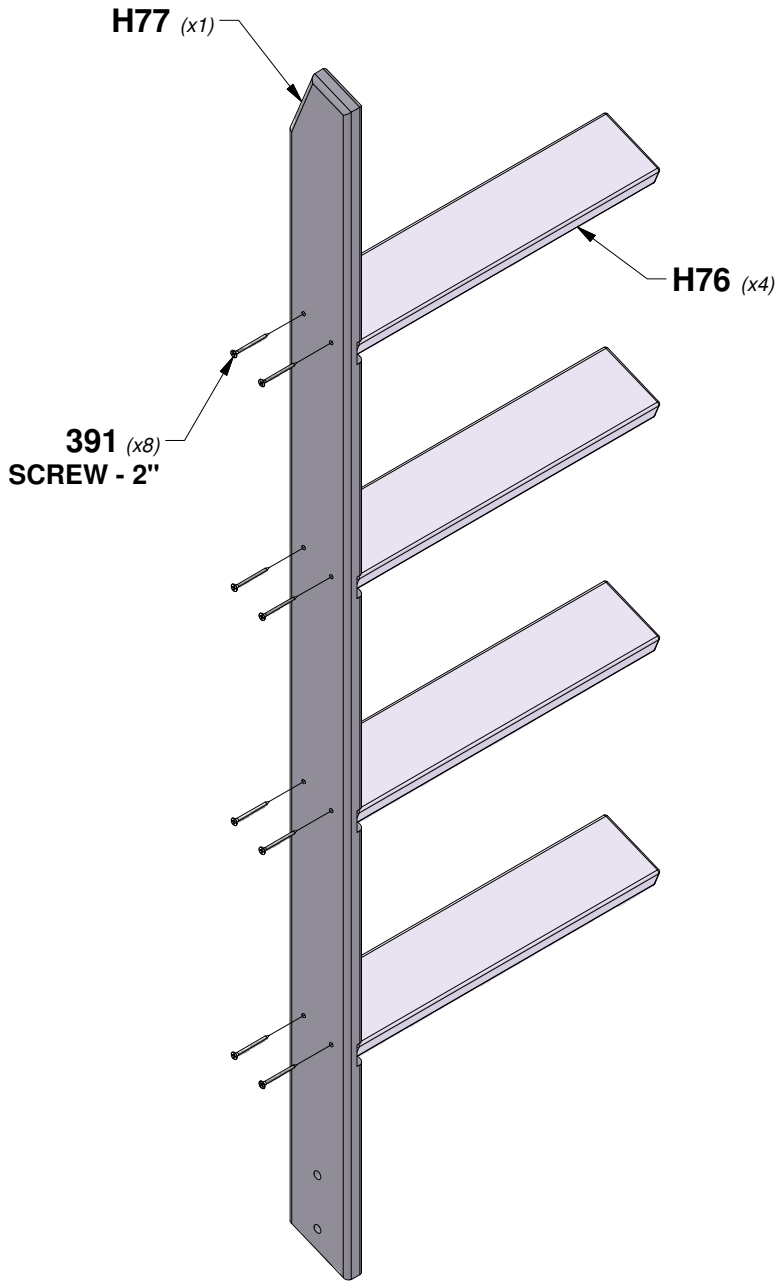

STEP 2 - LADDER ASSEMBLY

QTY	PART NUMBER	DESCRIPTION
8	H100391	SCREW PFH 8x2 BLK



H78 RIGHT UPRIGHT - W4L11174
(x1) 1"x3 3/8"x58" (24x86x1474)

TIP:
ALIGN PILOT HOLES

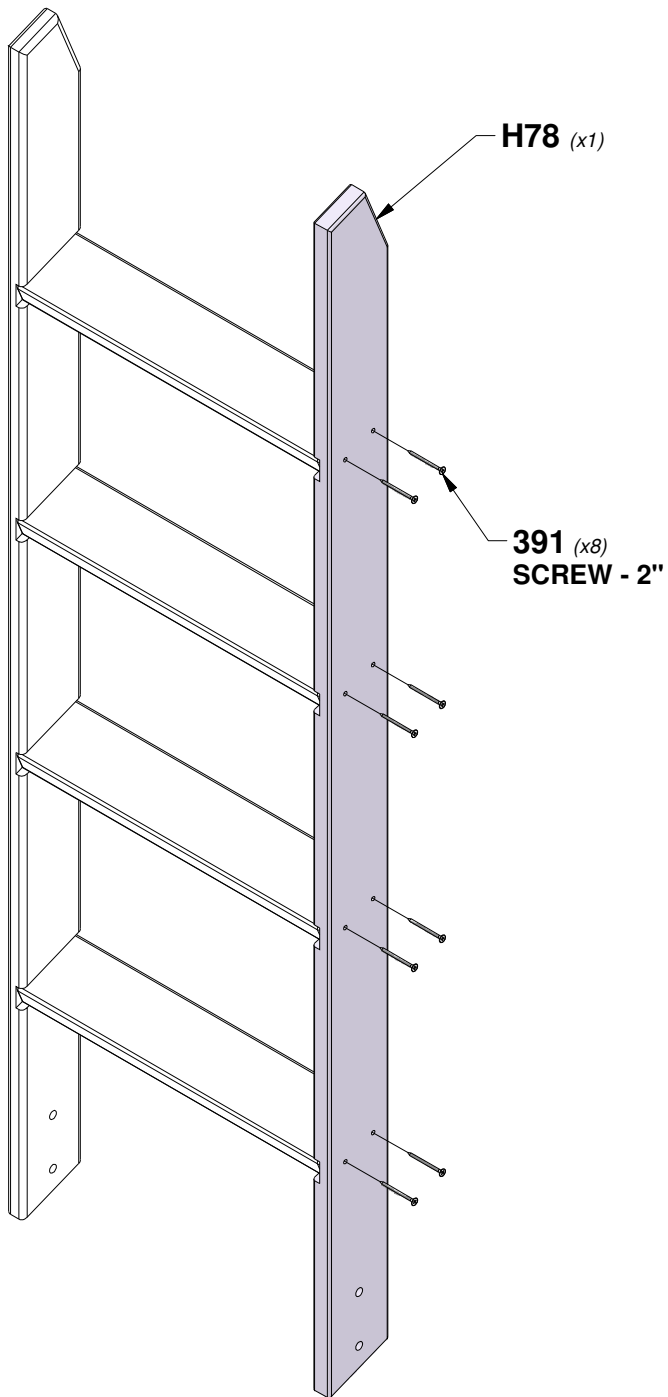

STEP 3 - LADDER ASSEMBLY

QTY	PART NUMBER	DESCRIPTION
4	H100200	SCREW PFH 8x1-1/2 BLK
4	H100391	SCREW PFH 8x2 BLK



H5 ATTACHMENT BOARD - W4L17639
 (x1) 1"x3 3/8"x18 1/4" (24x86x465)



M73 REAR SUPPORT - W4L18504
 (x1) 5/8"x3 3/8"x18 1/4" (16x86x465)

TIP:
ALIGN PILOT HOLES

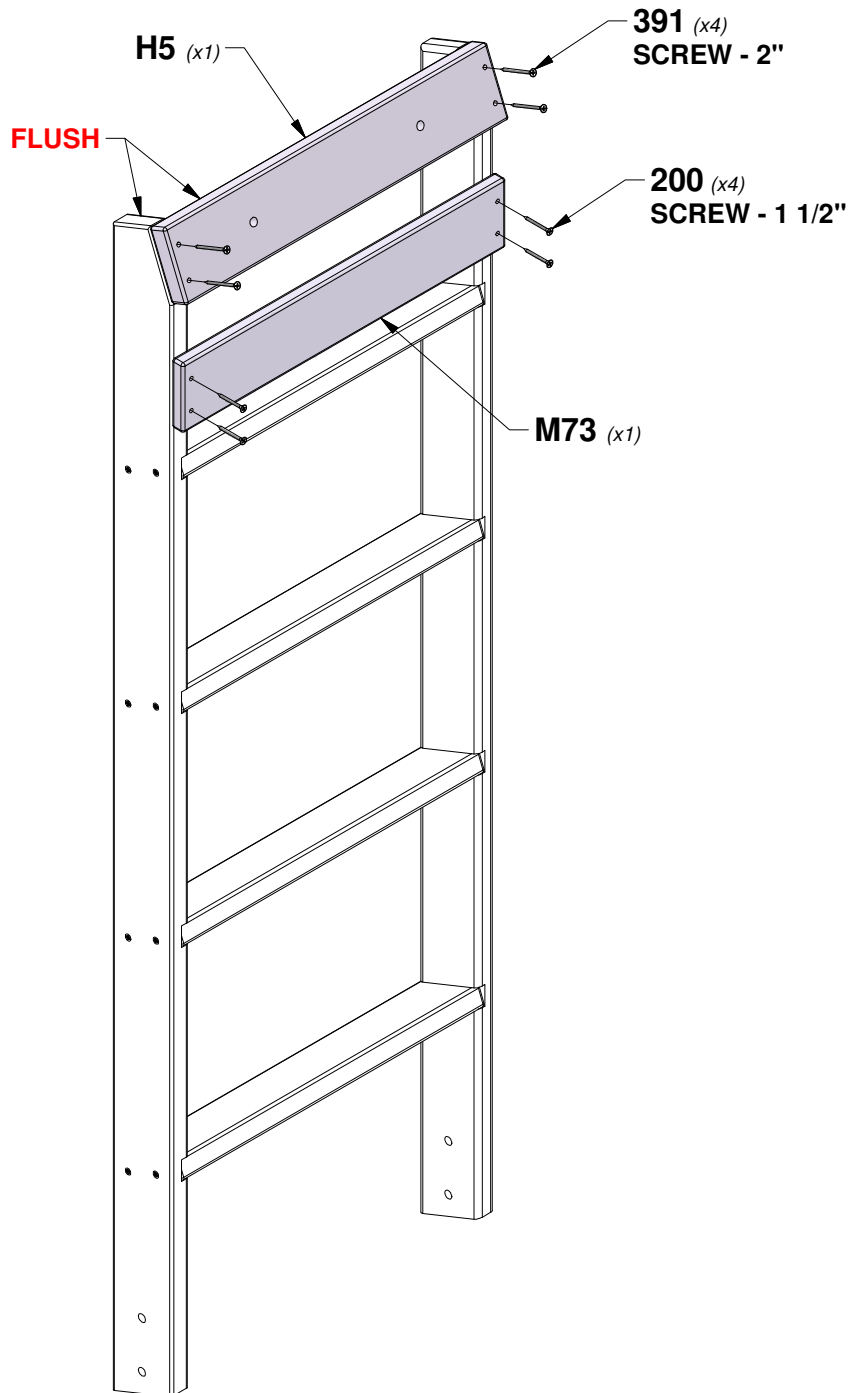

STEP 1 - ROCK WALL ASSEMBLY

QTY	PART NUMBER	DESCRIPTION
24	H100398	T-NUT 1/4 BLK
24	H100473	WASHER LOCK INT 8x15 BLK
24	H101111	BOLT WH 1/4x3/4 BLK



M75 ROCK WALL BOARD - W4L18501
(x4) 5/8"x3 3/8"x26 1/4" (16x86x667)



M76 ROCK WALL BOARD - W4L18502
(x4) 5/8"x3 3/8"x26 1/4" (16x86x667)

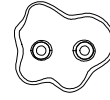

A6P00592 (x12) GREY HC ROCK #1

TIP:
INSTALL T-NUTS IN WOOD FIRST

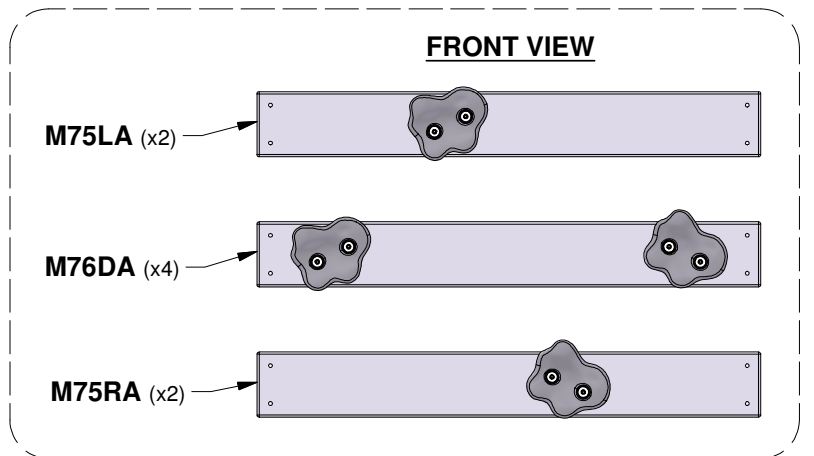
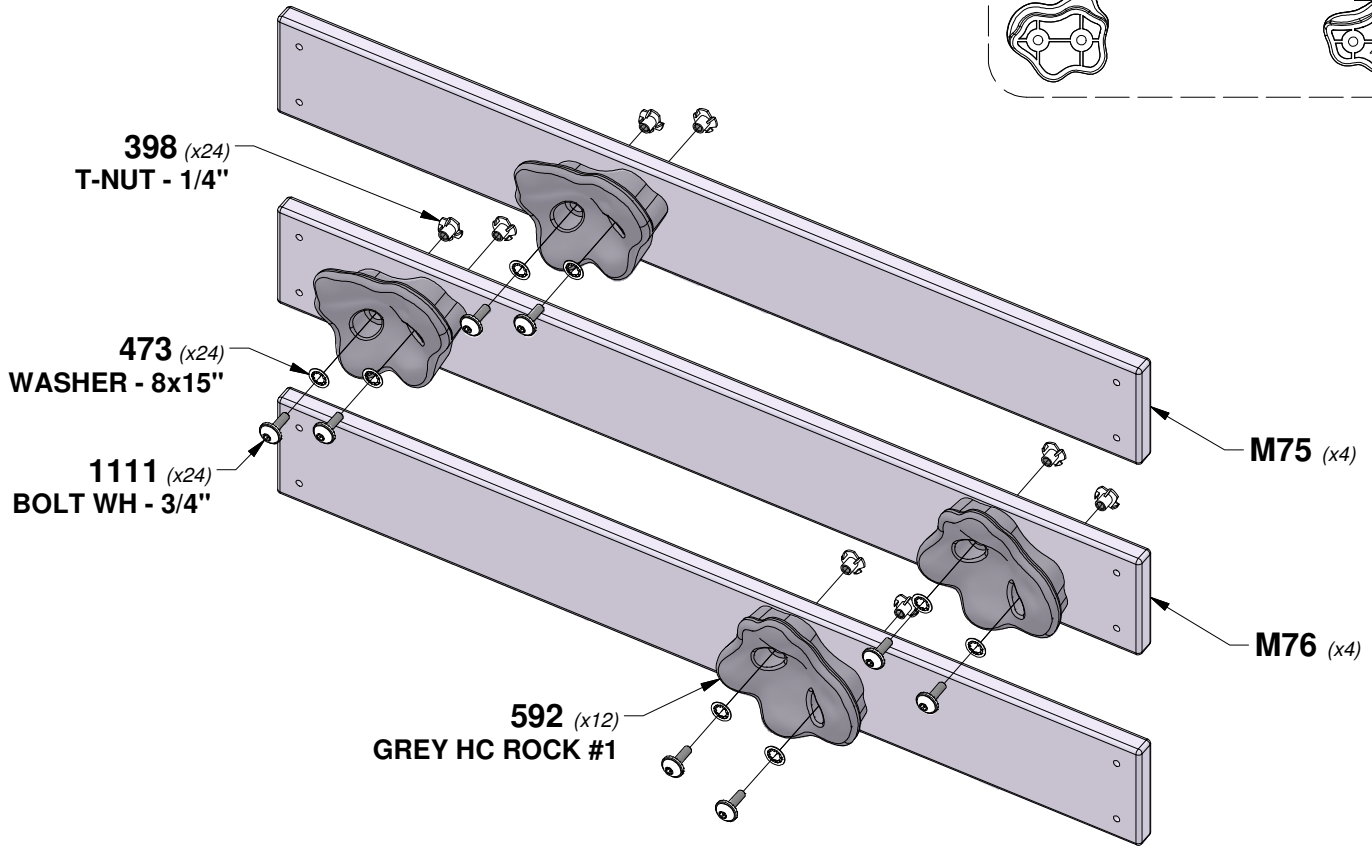
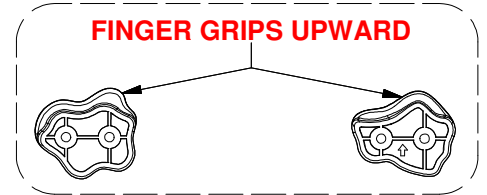

STEP 2 - ROCK WALL ASSEMBLY

QTY	PART NUMBER	DESCRIPTION
64	H100200	SCREW PFH 8x1-1/2 BLK

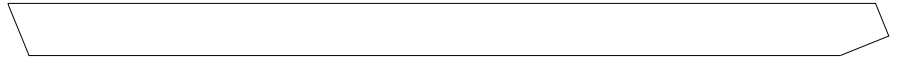
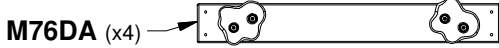
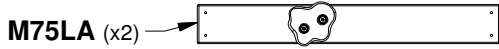

E72 RAIL - W4L17808
(x2) 1 3/8"x3 3/8"x57 3/8" (36x86x1457)



M74 ROCK WALL BOARD - W4L18500
(x7) 5/8"x3 3/8"x26 1/4" (16x86x667)



K01 ROCK WALL BOARD - W4L18503
(x1) 5/8"x5 1/4"x26 1/4" (16x134x667)

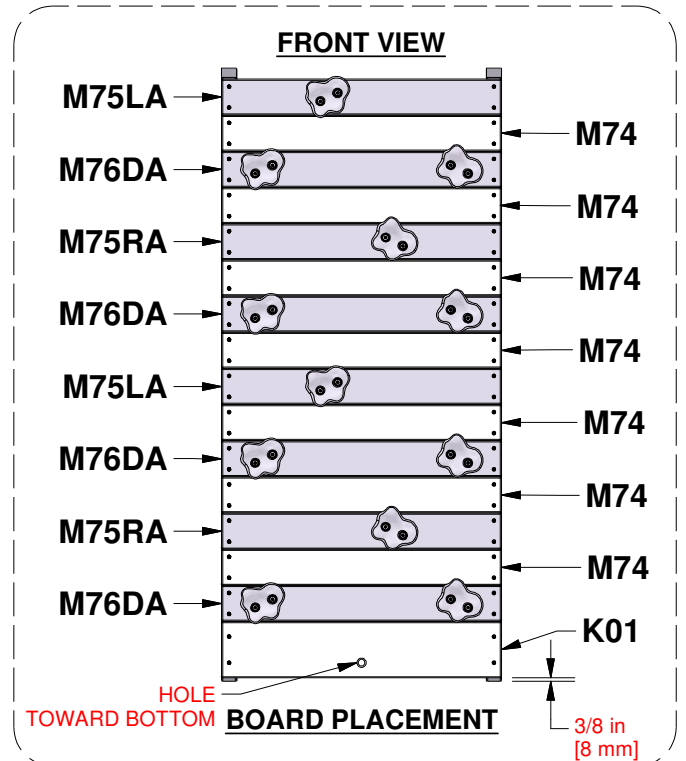
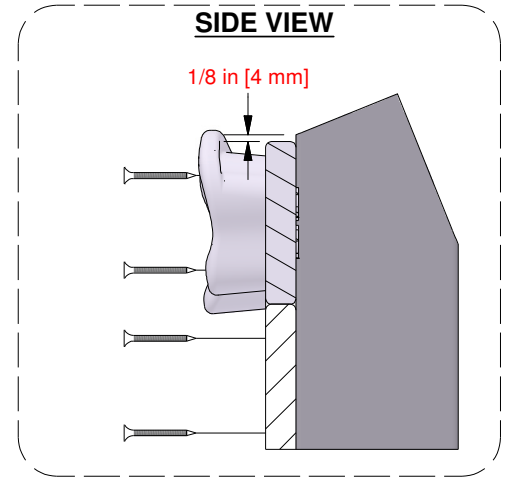
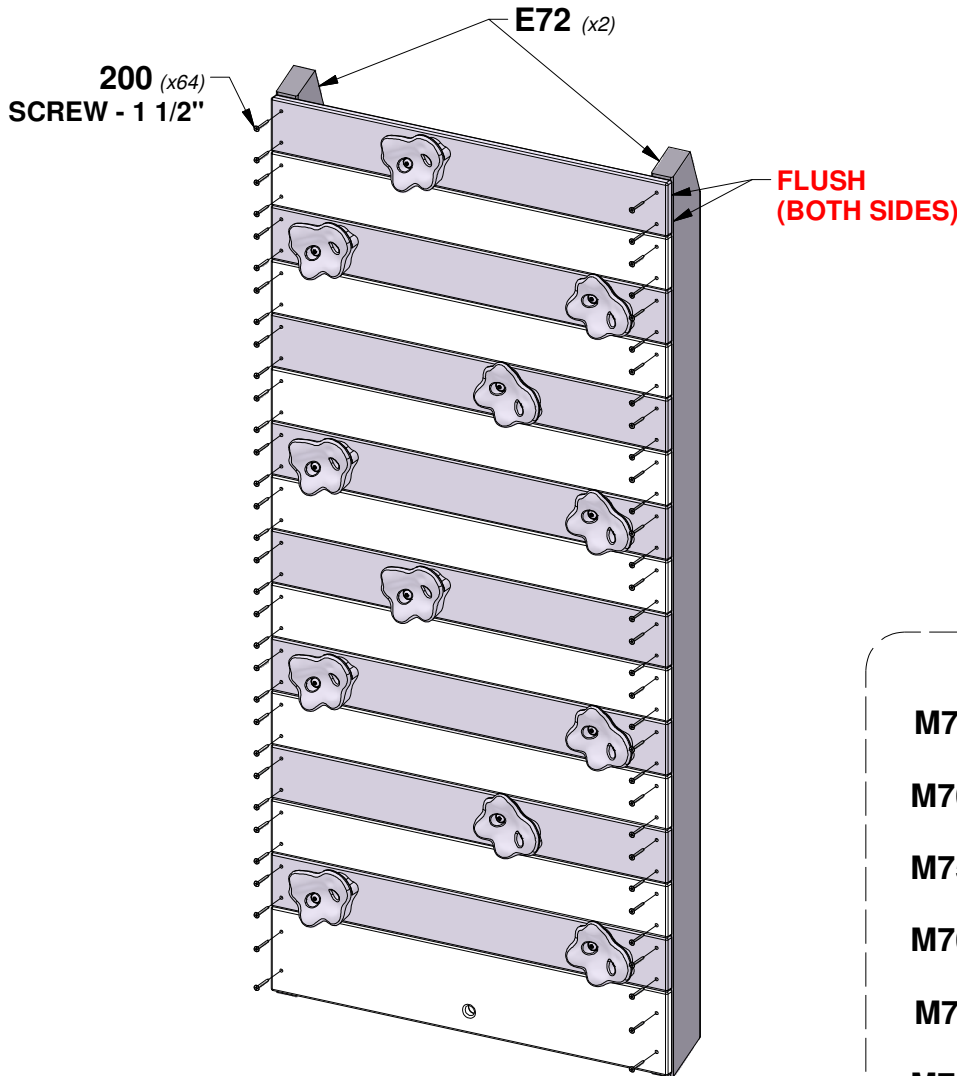

STEP 3 - ROCK WALL ASSEMBLY

QTY	PART NUMBER	DESCRIPTION
2	H100200	SCREW PFH 8x1-1/2 BLK



Y1 TOP BOARD - W4L17809
(x1) 5/8"x3 3/4"x26 1/4" (16x94x667)

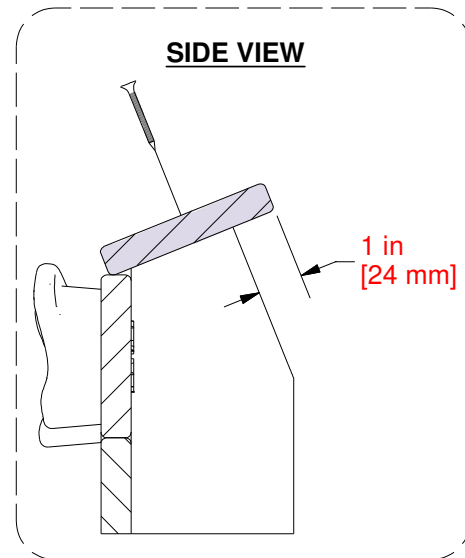
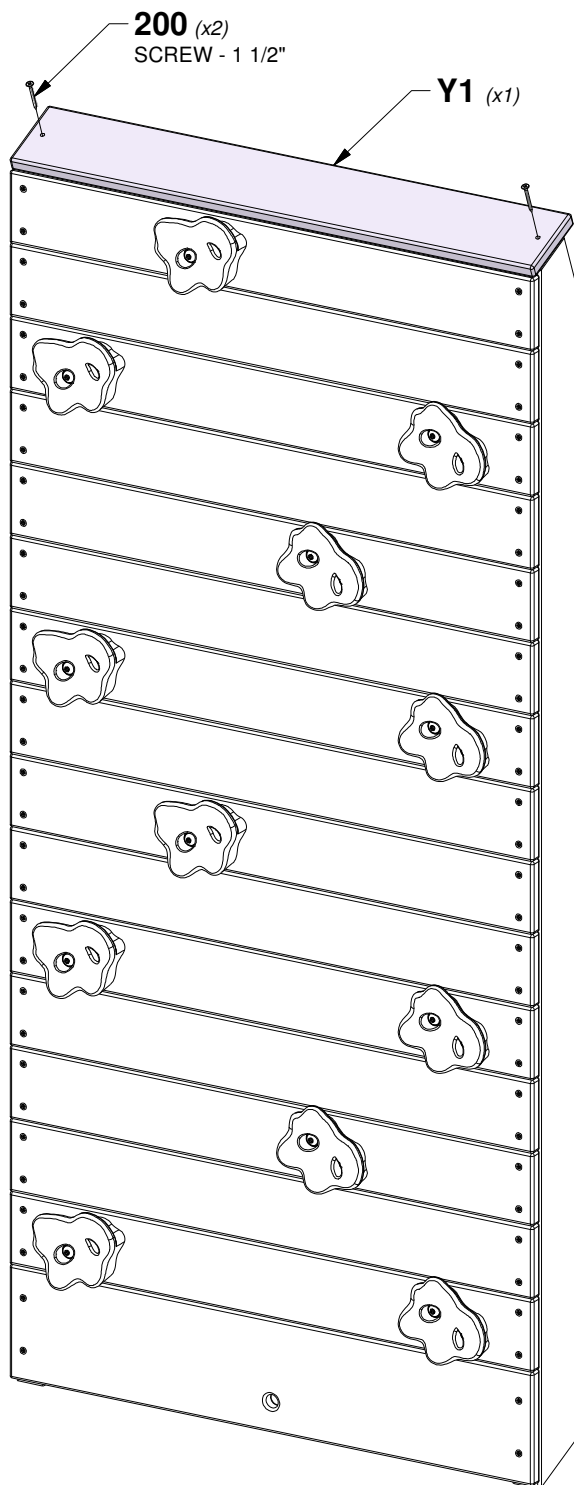

STEP 4 - ROCK WALL ASSEMBLY

QTY	PART NUMBER	DESCRIPTION
2	H100379	T-NUT 5/16 BLK
4	H100382	SCREW PFH 8x1-3/4 BLK



H9 ATTACHMENT BOARD - W4L17814
 (x1) 1"x3 3/8"x26 1/4" (24x86x667)

TIP:
INSTALL T-NUTS IN WOOD FIRST

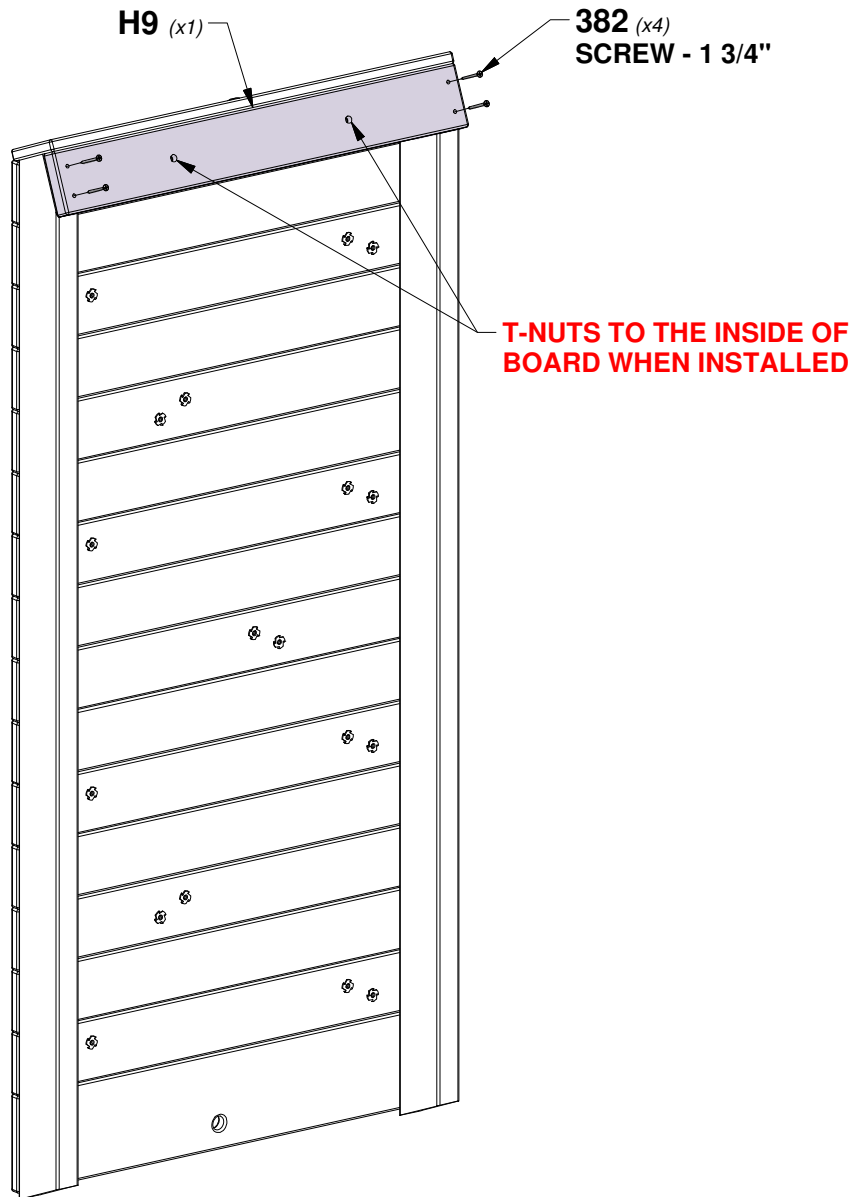
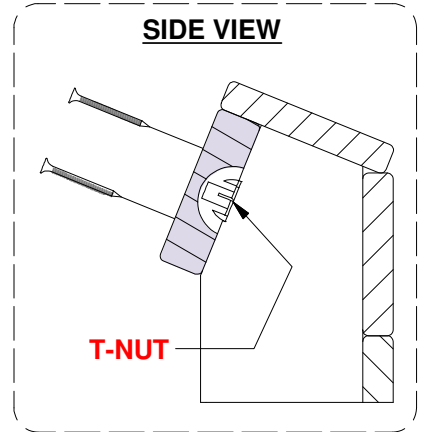
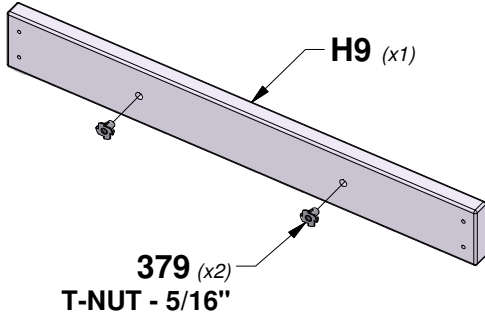

STEP 1 - SWING BEAM ASSEMBLY

QTY	PART NUMBER	DESCRIPTION
10	H100192	NUT BARREL WH 5/16x7/8 BLK
10	H100416	BOLT WH 5/16x3 BLK



A1 SWING BEAM EXTENDED - W4L18499
(x1) 3 3/8"x5 1/4"x89 1/2" (86x134x2274)



A2 SB 9" BLOCK - W4L19017
(x1) 3 3/8"x5 1/4"x9" (86x134x228)

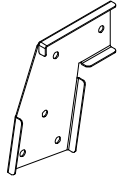

A4M00618 SWING BEAM EXTENSION BRACKET-RIGHT
(x1)

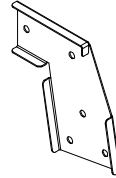

A4M00617 SWING BEAM EXTENSION BRACKET-LEFT
(x1)

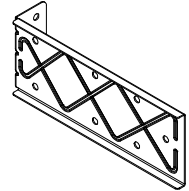

A4M01679 EXTENDED SWING BEAM BRACKET
(x2)

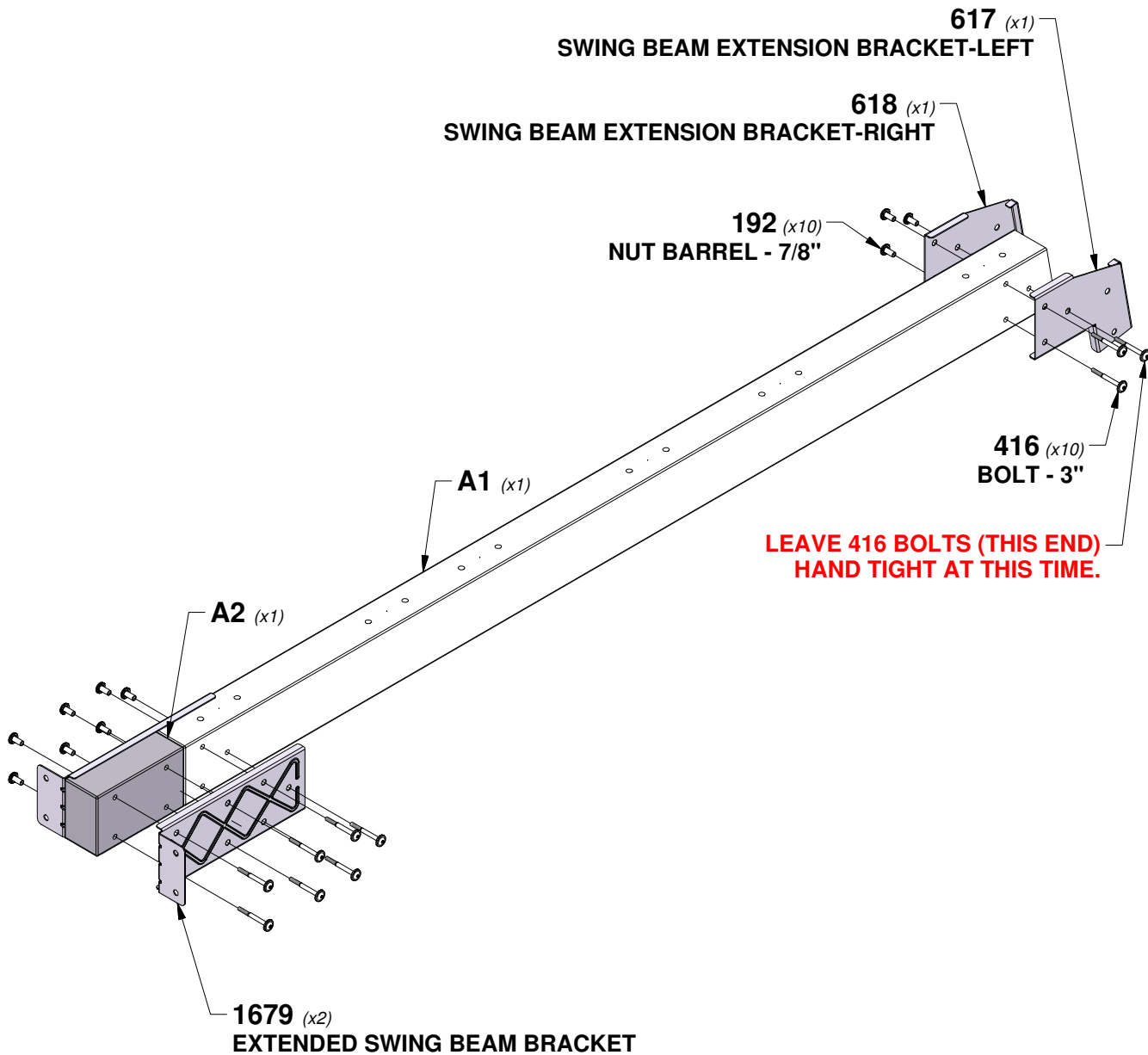

STEP 2 - SWING BEAM ASSEMBLY

QTY	PART NUMBER	DESCRIPTION
12	H101166	WASHER LOCK INT 10x18 BLK
12	H101167	WASHER FLAT 11x25
12	H101168	T-NUT 3/8 BLK
12	H101170	BOLT HEX 3/8x5-3/4

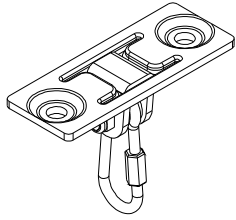

A4M02171
(x6) **SWING HANGER**

TIP:
INSTALL T-NUTS IN WOOD FIRST

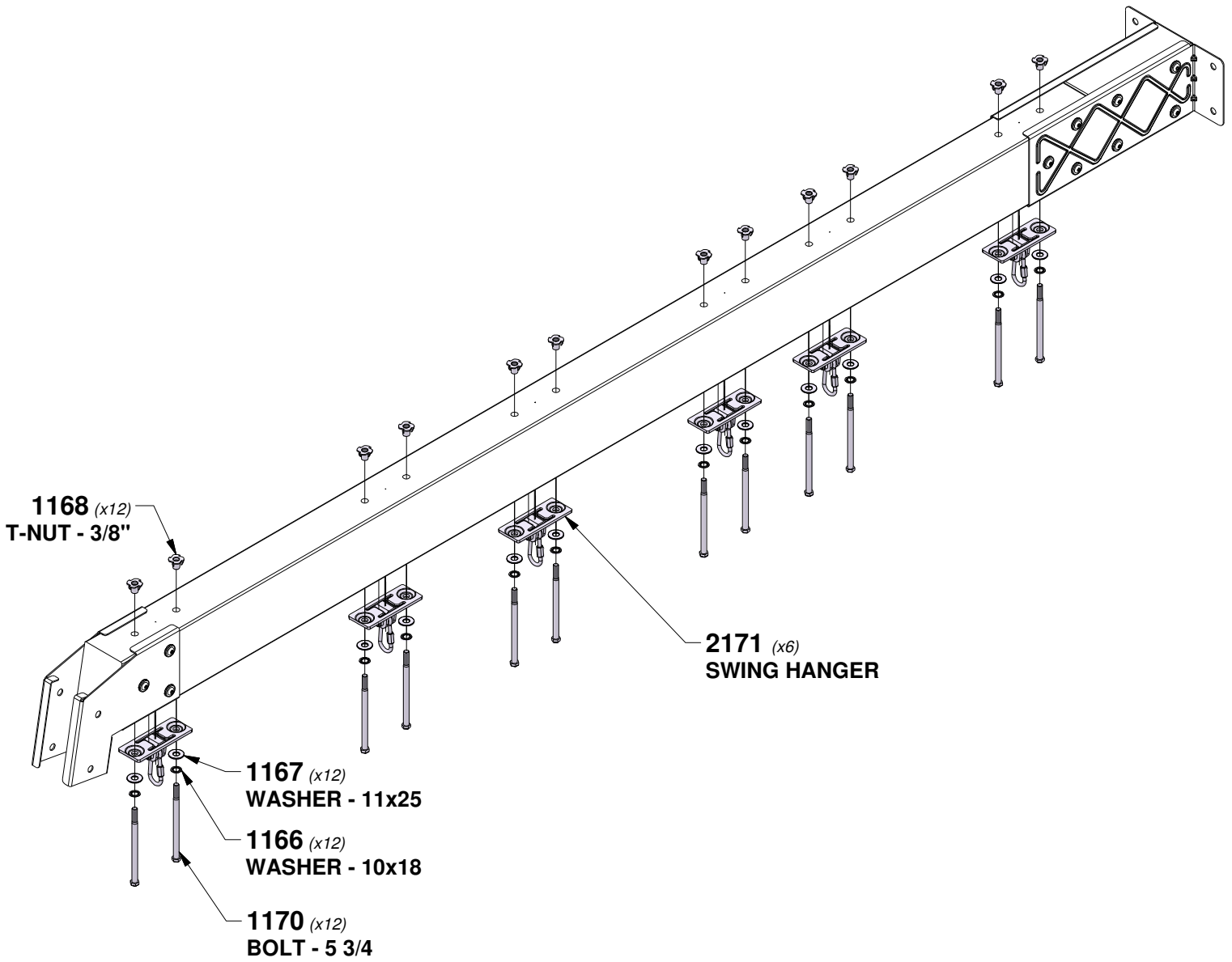

STEP 3 - SWING BEAM ASSEMBLY

QTY	PART NUMBER	DESCRIPTION
4	H100202	SCREW PWH 8x5/8 BLK



A100164
(x1) **BYD ID TAG (LARGE) AGES 3-10**

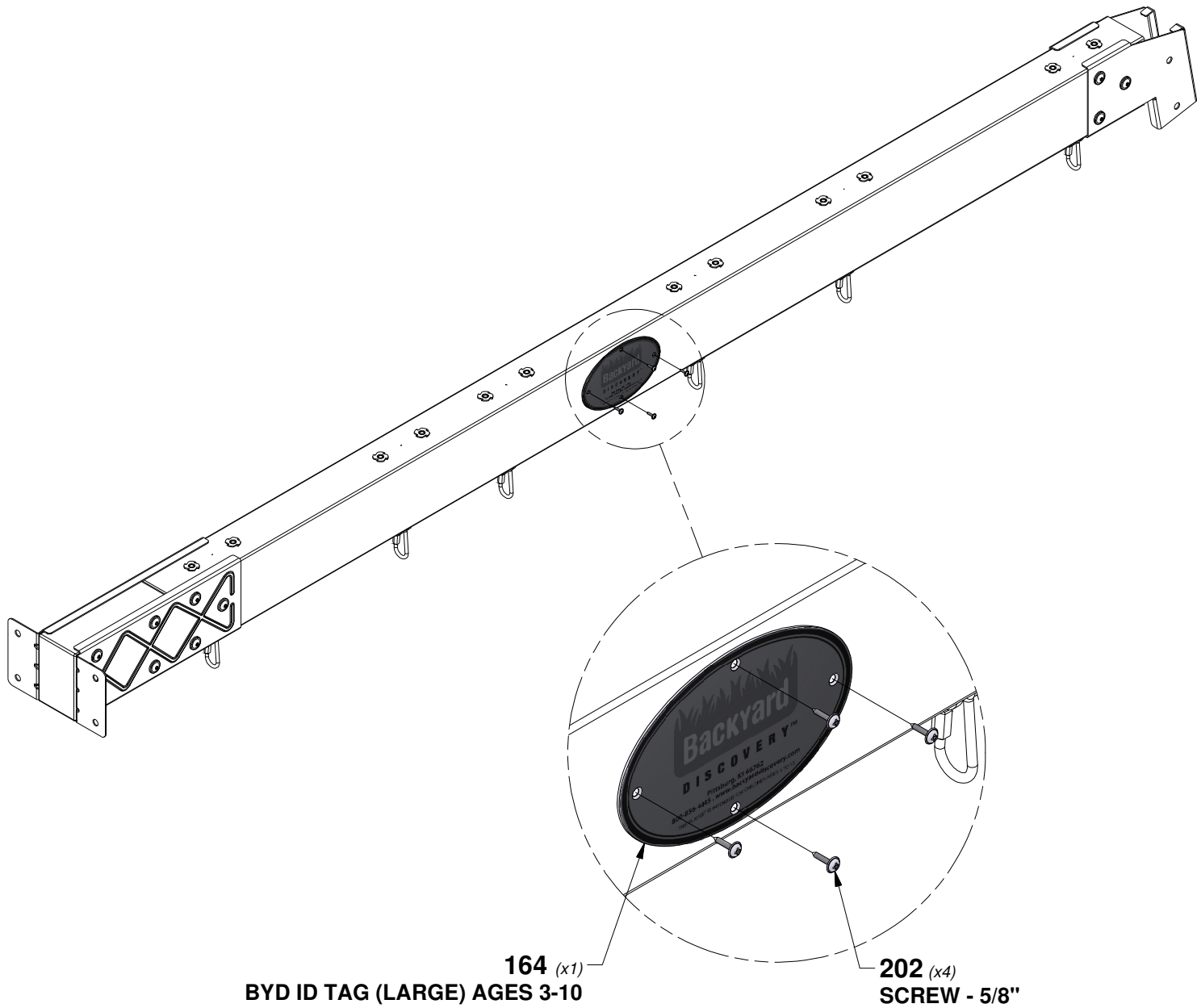

STEP 4 - SWING BEAM ASSEMBLY

QTY	PART NUMBER	DESCRIPTION
6	H100379	T-NUT 5/16 BLK
4	H100407	BOLT WH 5/16x1 1/2 BLK
2	H100503	BOLT WH 5/16x3-1/2 BLK



E77 ANGLE BRACE - W4L18495
(x2) 1 3/8"x3 3/8"x78" (36x86x1980)



SP71 SWING BEAM SUPPORT - W4L18498
(x1) 3 3/8"x3 3/8"x49 1/2" (86x86x1256)

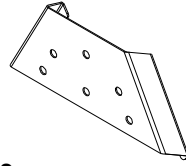

A4M01782 A-FRAME BRACKET
(x1)

TIP:
INSTALL T-NUTS IN WOOD FIRST

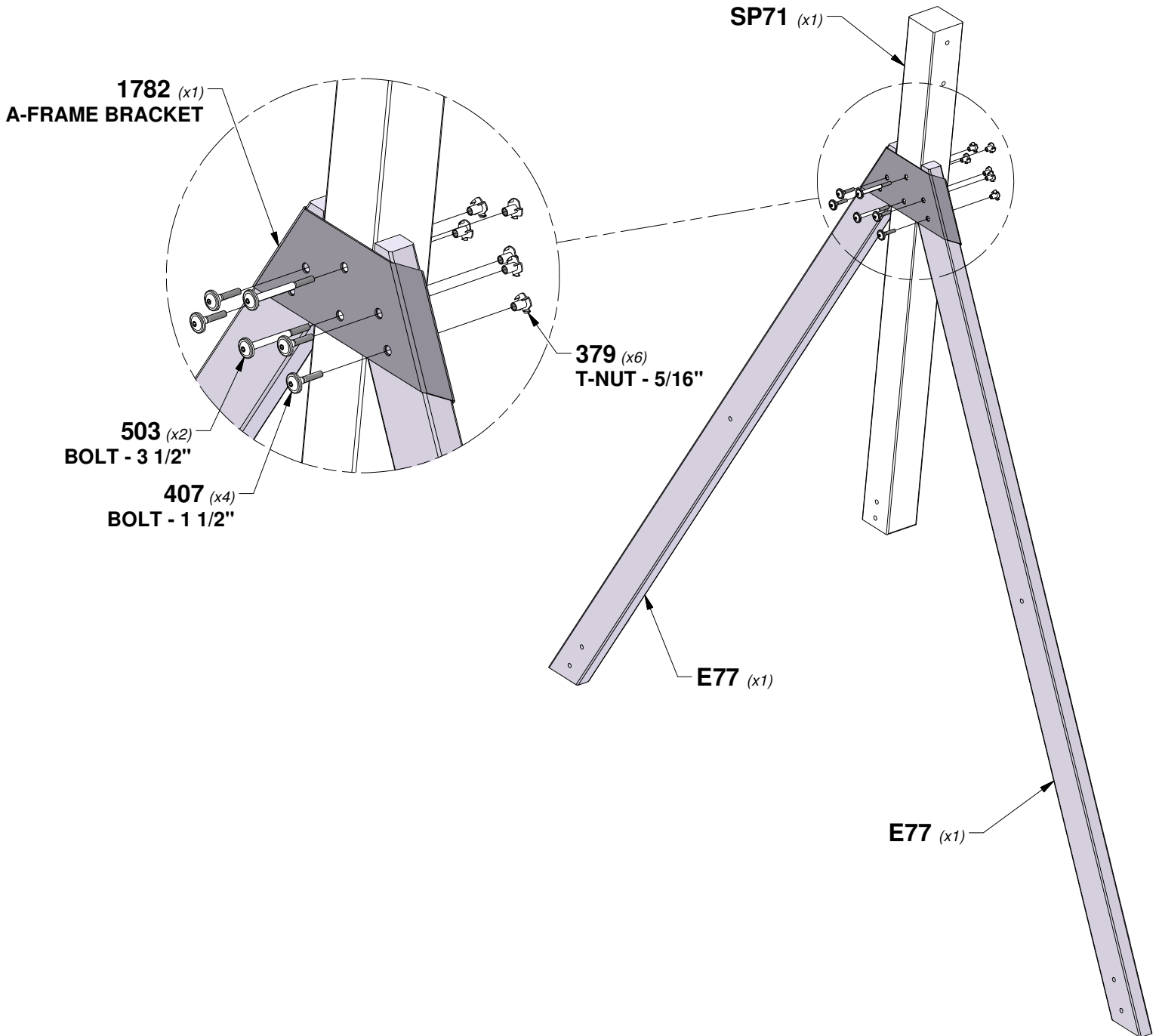

STEP 5 - SWING BEAM ASSEMBLY

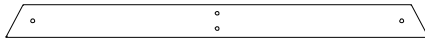

E79 END SUPPORT - W4L18496
(x1) 1 1/2"x3 1/2"x44" (36x86x1120)



G12 GROUND BOARD - W4L18497
(x1) 1"x5 1/4"x78 1/8" (24x134x1984)

QTY	PART NUMBER	DESCRIPTION
2	H100195	BOLT WH 5/16x2-3/4 BLK
8	H100198	WASHER LOCK EXT 8x19 BLK
4	H100205	BOLT WH 5/16x2-1/4 BLK
8	H100379	T-NUT 5/16 BLK
2	H100480	BOLT WH 5/16x4 3/4 BLK

TIP:
INSTALL T-NUTS IN WOOD FIRST

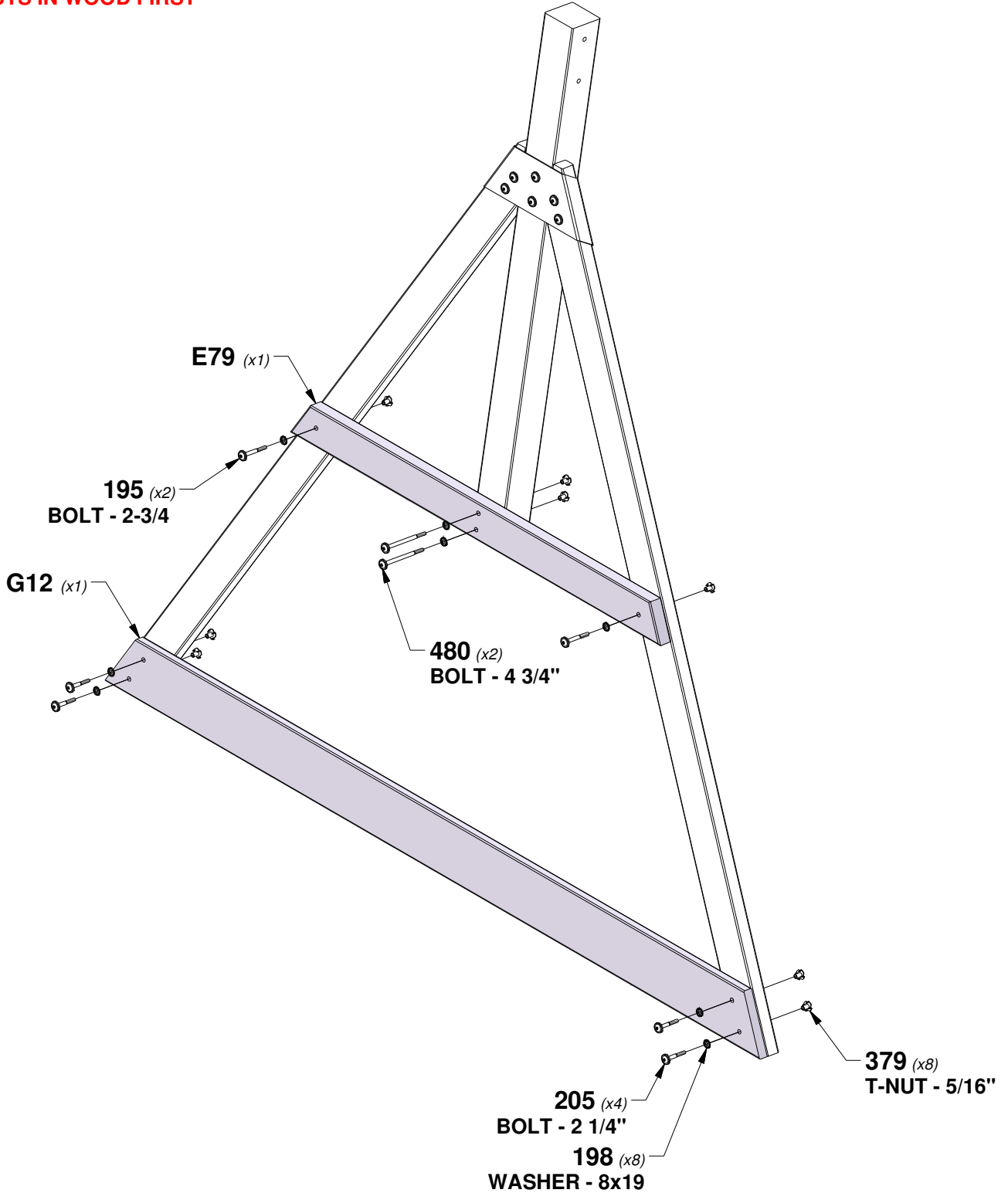

STEP 6 - SWING BEAM ASSEMBLY

QTY	PART NUMBER	DESCRIPTION
2	H100192	NUT BARREL WH 5/16x7/8 BLK
2	H100416	BOLT WH 5/16x3 BLK

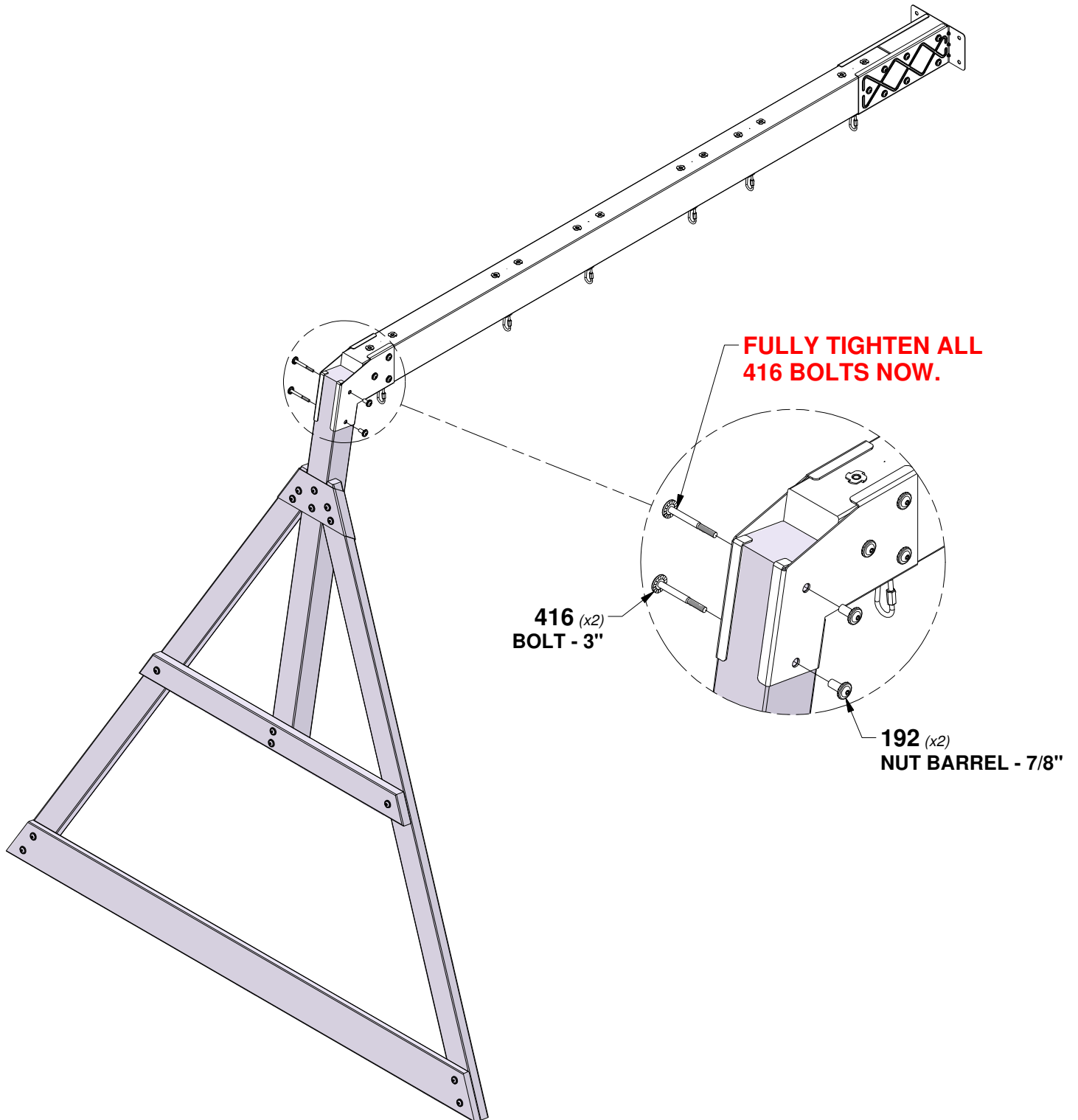

STEP 1 - FORT ASSEMBLY

QTY	PART NUMBER	DESCRIPTION
4	H100195	BOLT WH 5/16x2-3/4 BLK
8	H100198	WASHER LOCK EXT 8x19 BLK
12	H100379	T-NUT 5/16 BLK
4	H100457	BOLT WH 5/16x2 BLK



E7 RIGHT REAR UPRIGHT - W4L17831
(x1) 1 3/8"x3 3/8"x43 1/2" (36x86x1104)



E9 RIGHT FRONT UPRIGHT - W4L17833
(x1) 1 3/8"x3 3/8"x43 1/2" (36x86x1104)



D1 SWING BEAM MOUNT - W4L19015
(x1) 1 3/8"x5 1/4"x62 3/8" (36x134x1585)

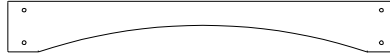

K12 ARCHED WALL RAIL - W4L11143
(x1) 5/8"x5 1/4"x40 5/8" (16x134x1032)

TIP:
INSTALL T-NUTS IN WOOD FIRST

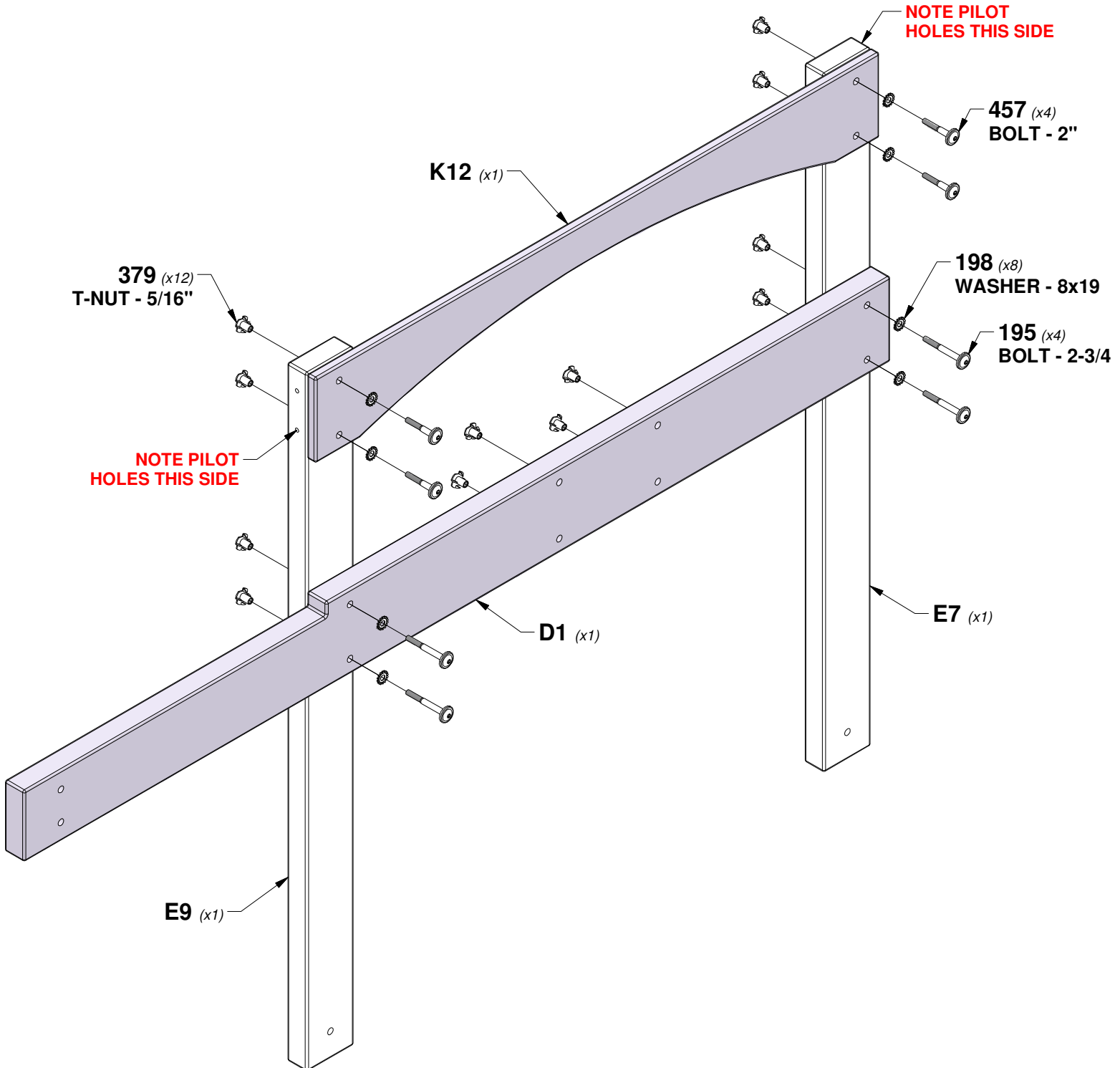

STEP 2 - FORT ASSEMBLY

QTY	PART NUMBER	DESCRIPTION
6	H100198	WASHER LOCK EXT 8x19 BLK
6	H100205	BOLT WH 5/16x2-1/4 BLK
6	H100379	T-NUT 5/16 BLK



G5 RIGHT CENTER WALL RAIL - W4L19006
(x1) 1"x5 1/4"x63 3/8" (24x134x1609)

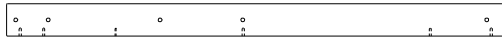

E4 RIGHT FRONT UPRIGHT - W4L17825
(x1) 1 3/8"x3 3/8"x51 3/4" (36x86x1314)



E13 RIGHT REAR UPRIGHT ASSEMBLY - W2A03847
(x1) 1 3/8"x3 3/8"x51 3/4" (36x86x1314)

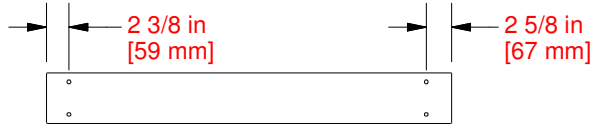

G2 GROUND BOARD - W4L19003
(x1) 1"x5 1/4"x42 1/4" (24x134x1072)

TIP:
INSTALL T-NUTS IN WOOD FIRST

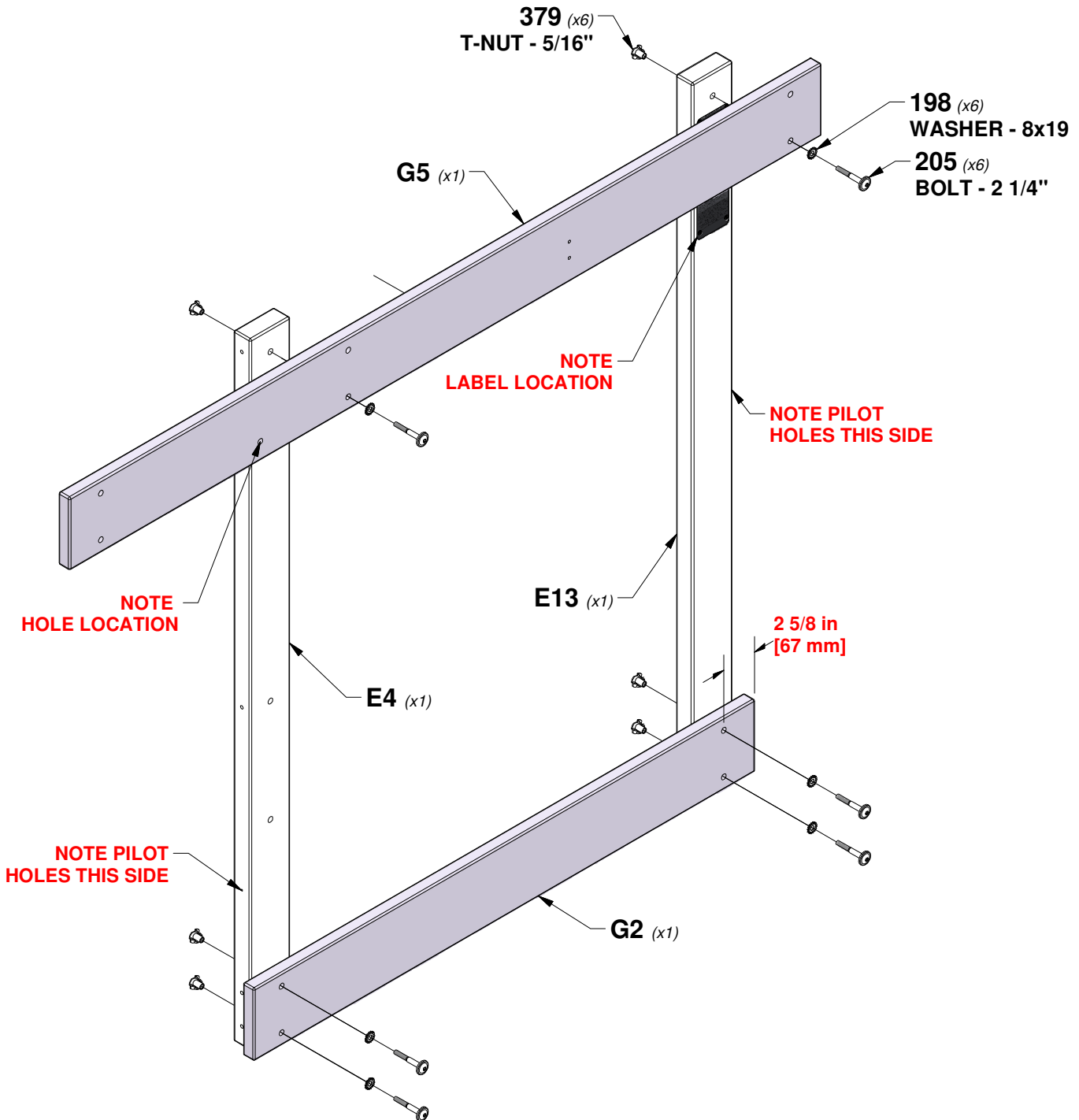

STEP 3 - FORT ASSEMBLY

QTY	PART NUMBER	DESCRIPTION
2	H100198	WASHER LOCK EXT 8x19 BLK
2	H100205	BOLT WH 5/16x2-1/4 BLK
2	H100379	T-NUT 5/16 BLK

TIP:
INSTALL T-NUTS IN WOOD FIRST

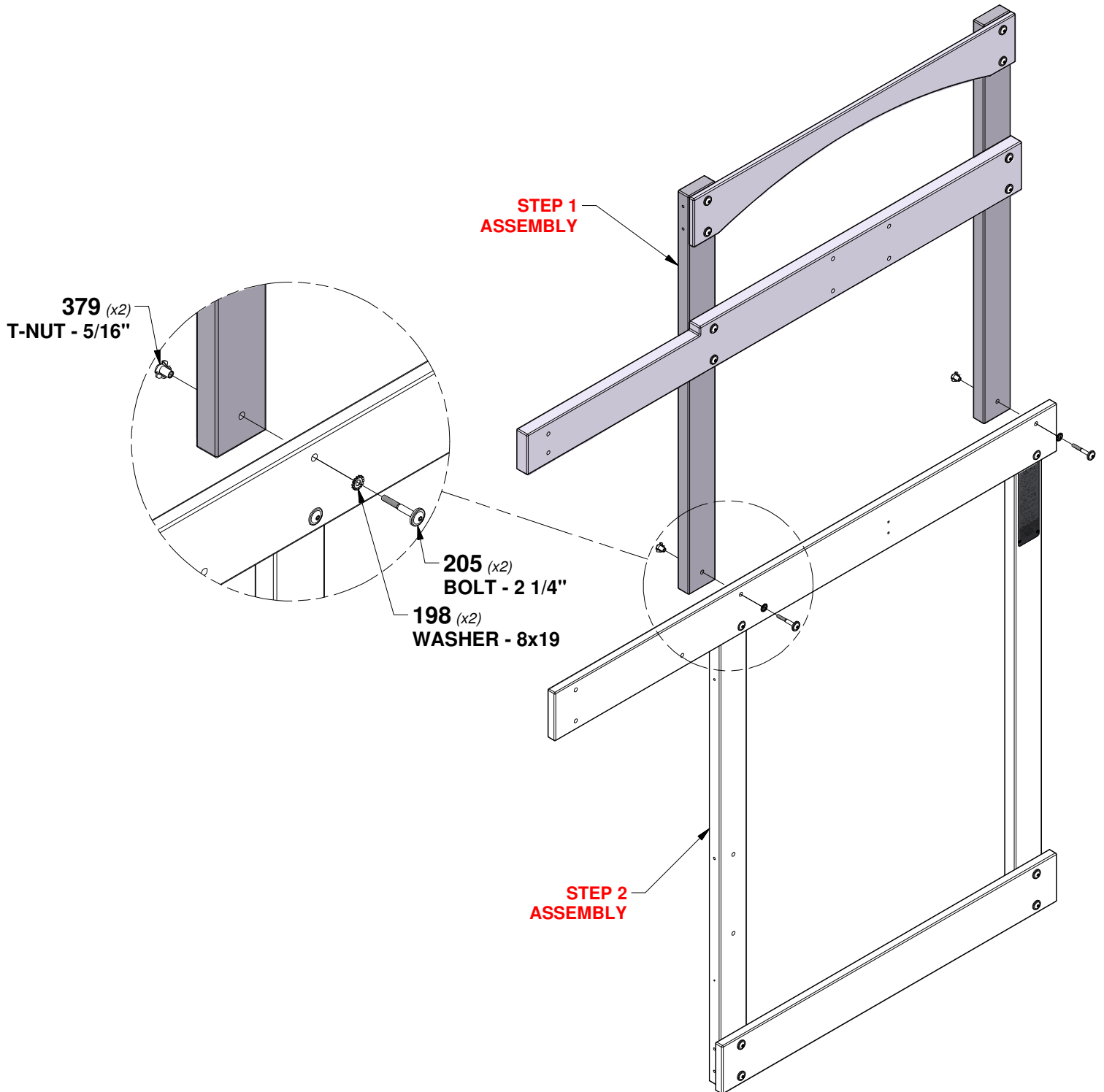

STEP 4 - FORT ASSEMBLY

QTY	PART NUMBER	DESCRIPTION
12	H100198	WASHER LOCK EXT 8x19 BLK
12	H100205	BOLT WH 5/16x2-1/4 BLK
12	H100379	T-NUT 5/16 BLK

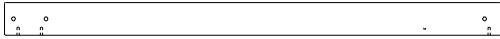

E2 LEFT REAR UPRIGHT - W4L17823

(x1) 1 3/8"x3 3/8"x51 3/4" (36x86x1314)

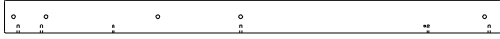

E3 LEFT FRONT UPRIGHT - W4L17824

(x1) 1 3/8"x3 3/8"x51 3/4" (36x86x1314)

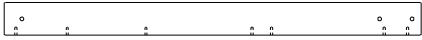

E6 LEFT REAR UPRIGHT - W4L19001

(x1) 1 3/8"x3 3/8"x43 1/2" (36x86x1104)



E8 LEFT FRONT UPRIGHT - W4L19002

(x1) 1 3/8"x3 3/8"x43 1/2" (36x86x1104)

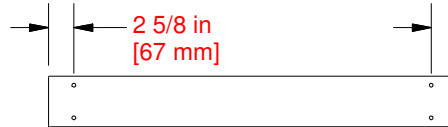

G3 GROUND BOARD - W4L19004

(x1) 1"x5 1/4"x42 1/4" (24x134x1072)

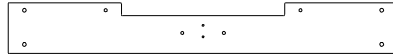

G8 LEFT CENTER WALL RAIL - W4L19000

(x1) 1"x5 1/4"x40 5/8" (24x134x1032)



G13 ARCHED WALL RAIL - W4L19010

(x1) 1"x5 1/4"x40 5/8" (24x134x1032)

TIP:
INSTALL T-NUTS IN WOOD FIRST

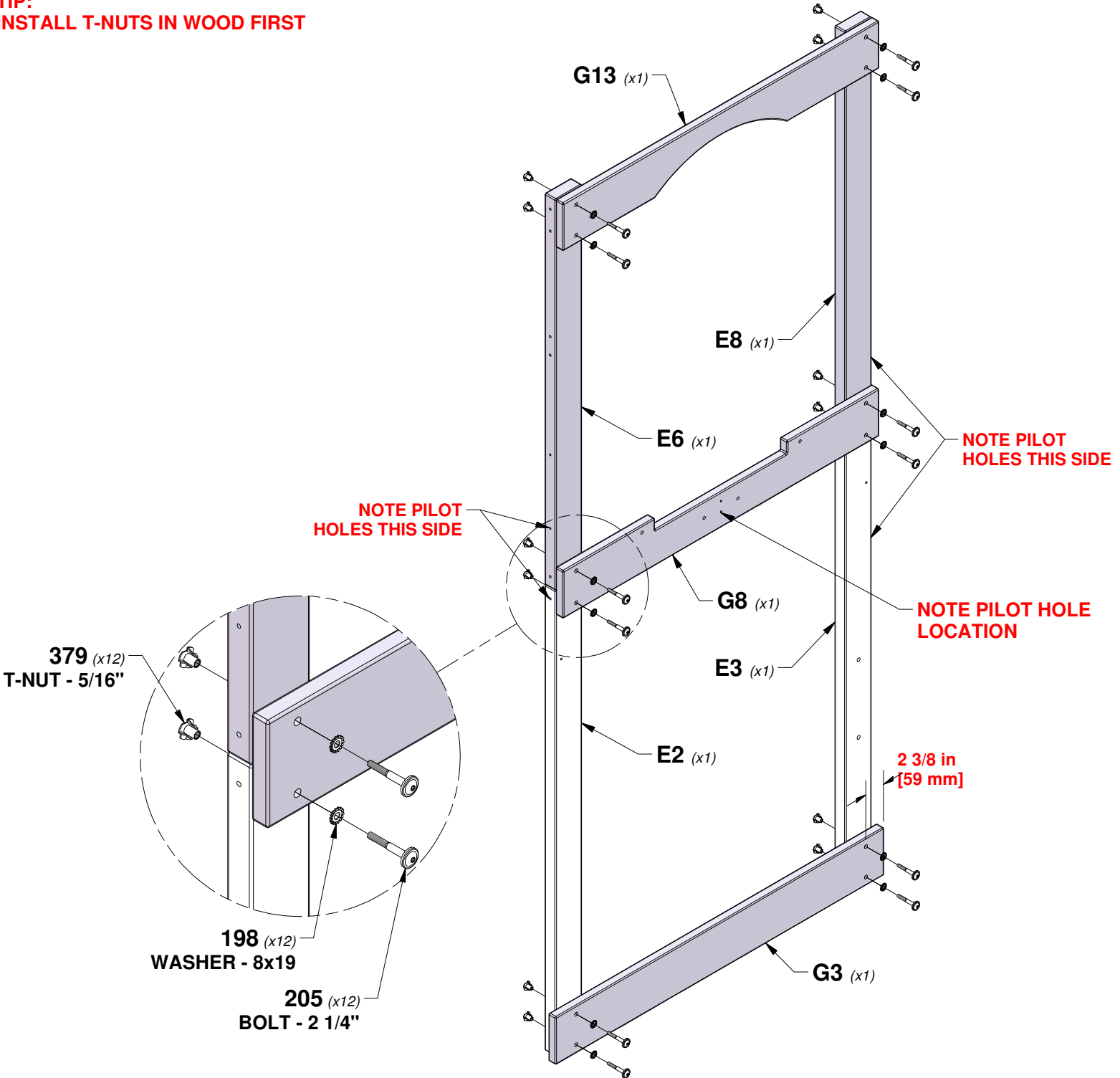

STEP 5 - FORT ASSEMBLY

QTY	PART NUMBER	DESCRIPTION
3	H100197	LAG SCREW WH 5/16x2-1/2 BLK
12	H100198	WASHER LOCK EXT 8x19 BLK
2	H100206	LAG SCREW WH 5/16x3 BLK
8	H100458	LAG SCREW WH 5/16x2 BLK



G6 FRONT CENTER WALL RAIL - W4L19014
(x1) 1"x5 1/4"x61 3/4" (24x134x1570)



K4 GROUND BOARD - W4L19009
(x1) 5/8"x5 1/4"x40 1/2" (16x134x1030)

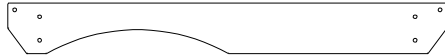

G15 ANGLED WALL RAIL - W4L19012
(x1) 1"x5 1/4"x45 3/4" (24x134x1162)

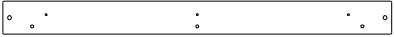

M1 WALL RAIL - W4L19013
(x1) 5/8"x3 3/8"x40 1/2" (16x86x1030)



J1 PORCH GROUND BOARD - W4L11128
(x1) 1"x2 3/8"x40 1/2" (24x60x1030)

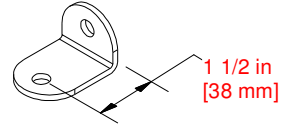

A4M00710 L BRACKET BLACK 32x51
(x1)

1 3/8 in
[36 mm]

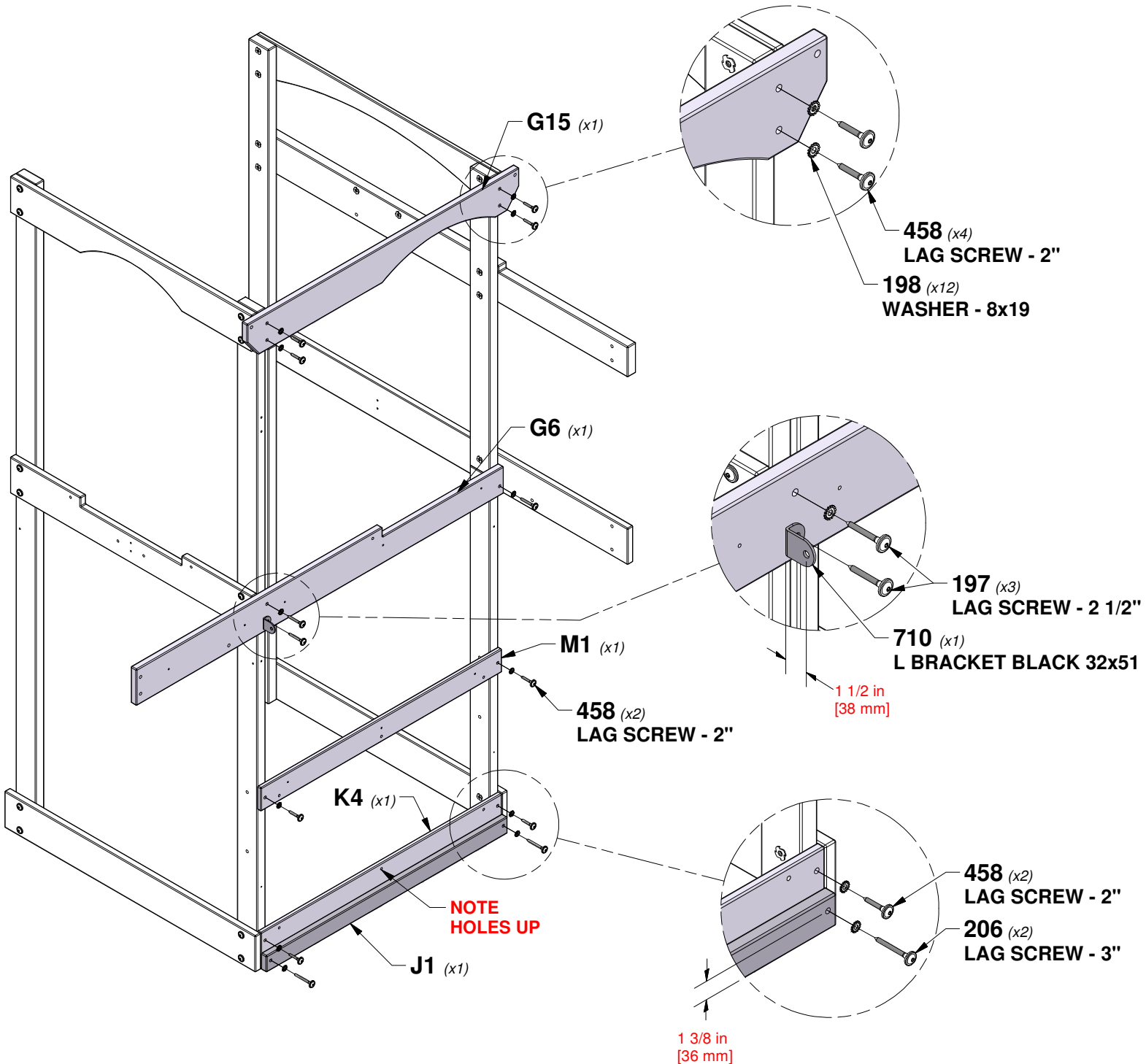

STEP 6 - FORT ASSEMBLY

QTY	PART NUMBER	DESCRIPTION
8	H100197	LAG SCREW WH 5/16x2-1/2 BLK
12	H100198	WASHER LOCK EXT 8x19 BLK
2	H100379	T-NUT 5/16 BLK
4	H100458	LAG SCREW WH 5/16x2 BLK

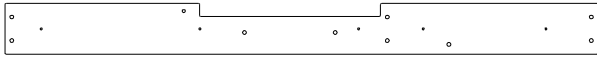

G7 REAR CENTER WALL RAIL - W4L19007
(x1) 1"x5 1/4"x61 3/4" (24x134x1570)

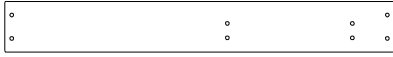

G4 GROUND BOARD - W4L19005
(x1) 1"x5 1/4"x40 1/2" (24x134x1030)



G14 ANGLED WALL RAIL - W4L19011
(x1) 1"x5 1/4"x45 3/4" (24x134x1162)

TIP:
INSTALL T-NUTS IN WOOD FIRST

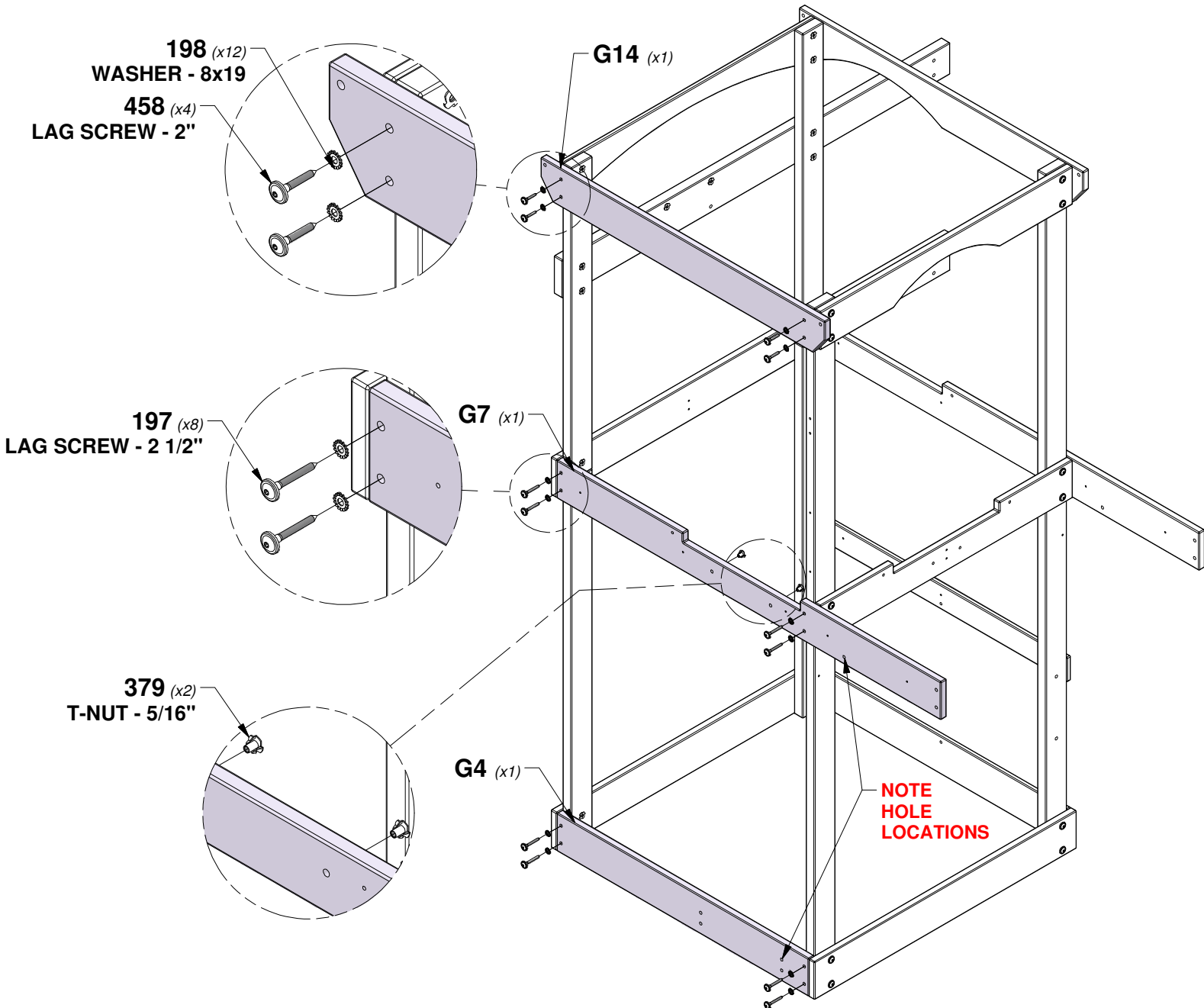

STEP 7 - FORT ASSEMBLY

QTY	PART NUMBER	DESCRIPTION
4	H100197	LAG SCREW WH 5/16x2-1/2 BLK
3	H100198	WASHER LOCK EXT 8x19 BLK

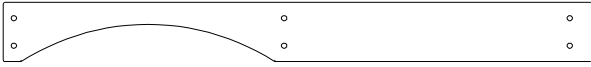

Q6 **ARCHED WALL RAIL - W4L19016**
 (x1) 1"x4 3/8"x43 7/8" (24x112x1113)



Q4 **WALL RAIL - W4L17654**
 (x1) 1"x4 3/8"x23 5/8" (24x112x600)

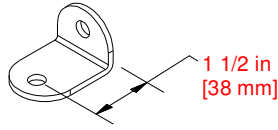

A4M00710 **L BRACKET**
 (x1) **BLACK 32x51**

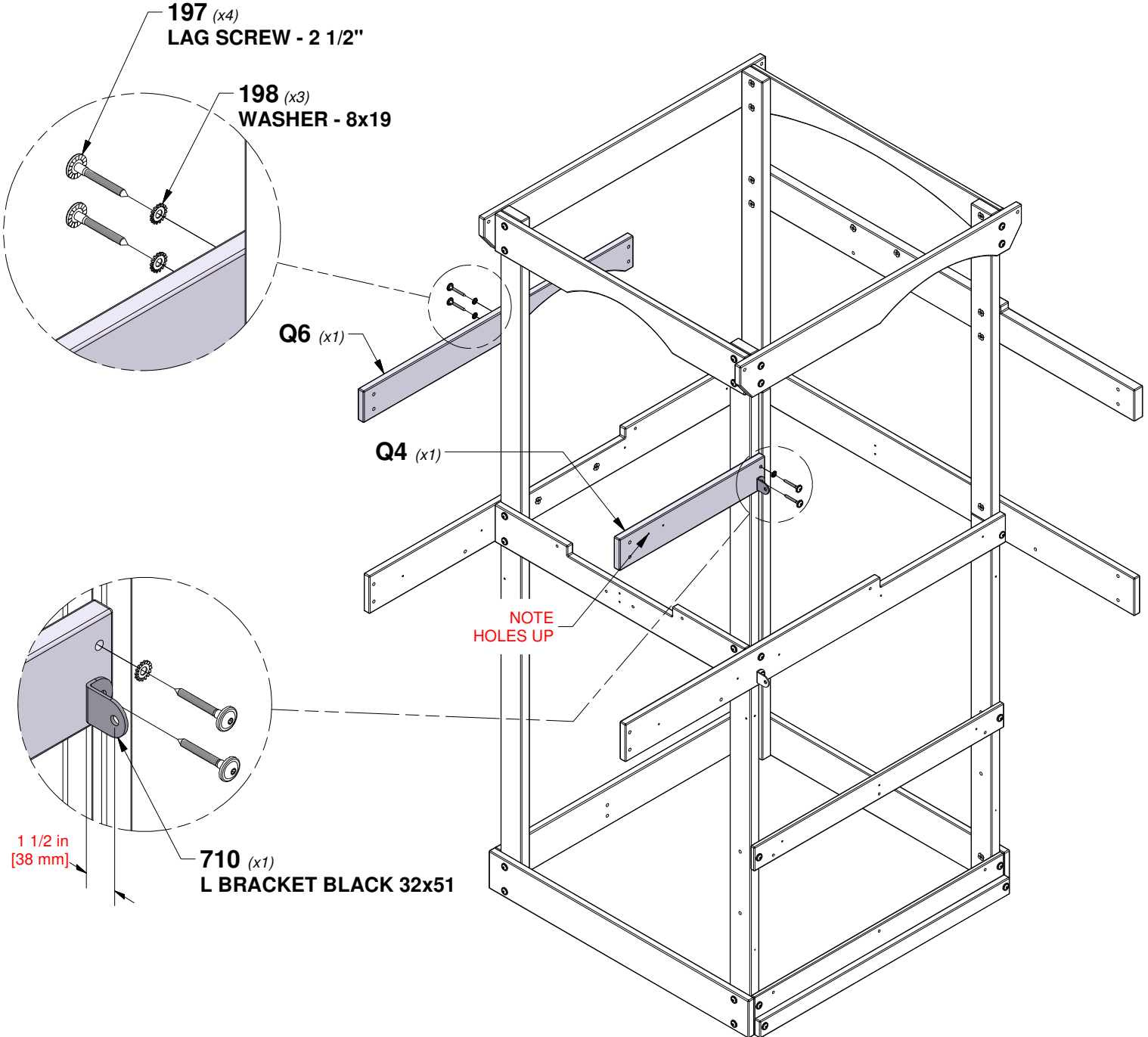

STEP 8 - FORT ASSEMBLY

QTY	PART NUMBER	DESCRIPTION
8	H100197	LAG SCREW WH 5/16x2-1/2 BLK
16	H100198	WASHER LOCK EXT 8x19 BLK
8	H100205	BOLT WH 5/16x2-1/4 BLK
8	H100379	T-NUT 5/16 BLK

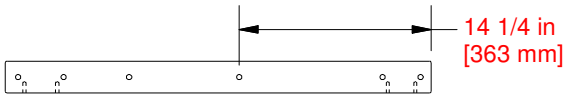

F1 RIGHT BALCONY UPRIGHT - W4L17806
(x1) 1 3/8"x2 3/8"x31 3/4" (36x60x805)



F2 LEFT BALCONY UPRIGHT - W4L17807
(x1) 1 3/8"x2 3/8"x31 3/4" (36x60x805)

PILOT HOLES INWARD WHEN INSTALLED

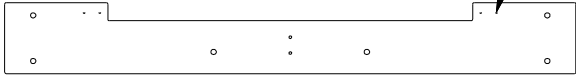

G11 LEFT SIDE WALL BOARD - W4L19008
(x1) 1"x5 1/4"x42 1/2" (24x134x1080)

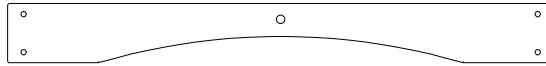

Q1 ARCHED WALL RAIL - W4L11142
(x1) 1"x4 3/8"x40 5/8" (24x112x1032)

TIP:
INSTALL T-NUTS IN WOOD FIRST

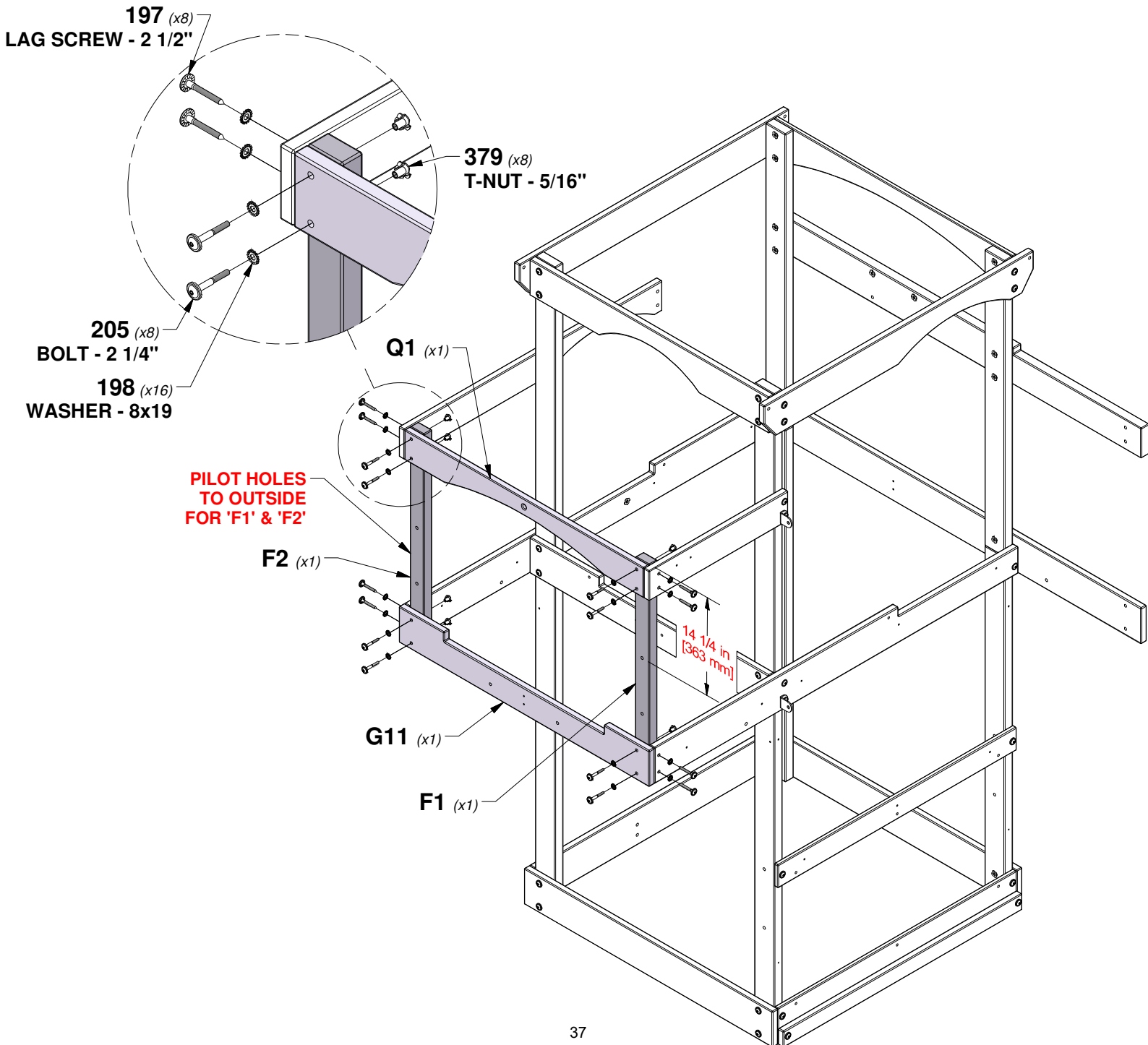

STEP 9 - FORT ASSEMBLY

QTY	PART NUMBER	DESCRIPTION
2	H100198	WASHER LOCK EXT 8x19 BLK
2	H100205	BOLT WH 5/16x2-1/4 BLK
2	H100379	T-NUT 5/16 BLK
2	H100403	LAG SCREW WH 1/4x1-1/2 BLK
2	H100405	WASHER LOCK EXT 6x15 BLK

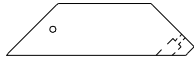

E1 DECK BRACE - W4L17821
 (x2) 1 3/8"x3 3/8"x12 1/4" (36x86x311)

TIP:
INSTALL T-NUTS IN WOOD FIRST

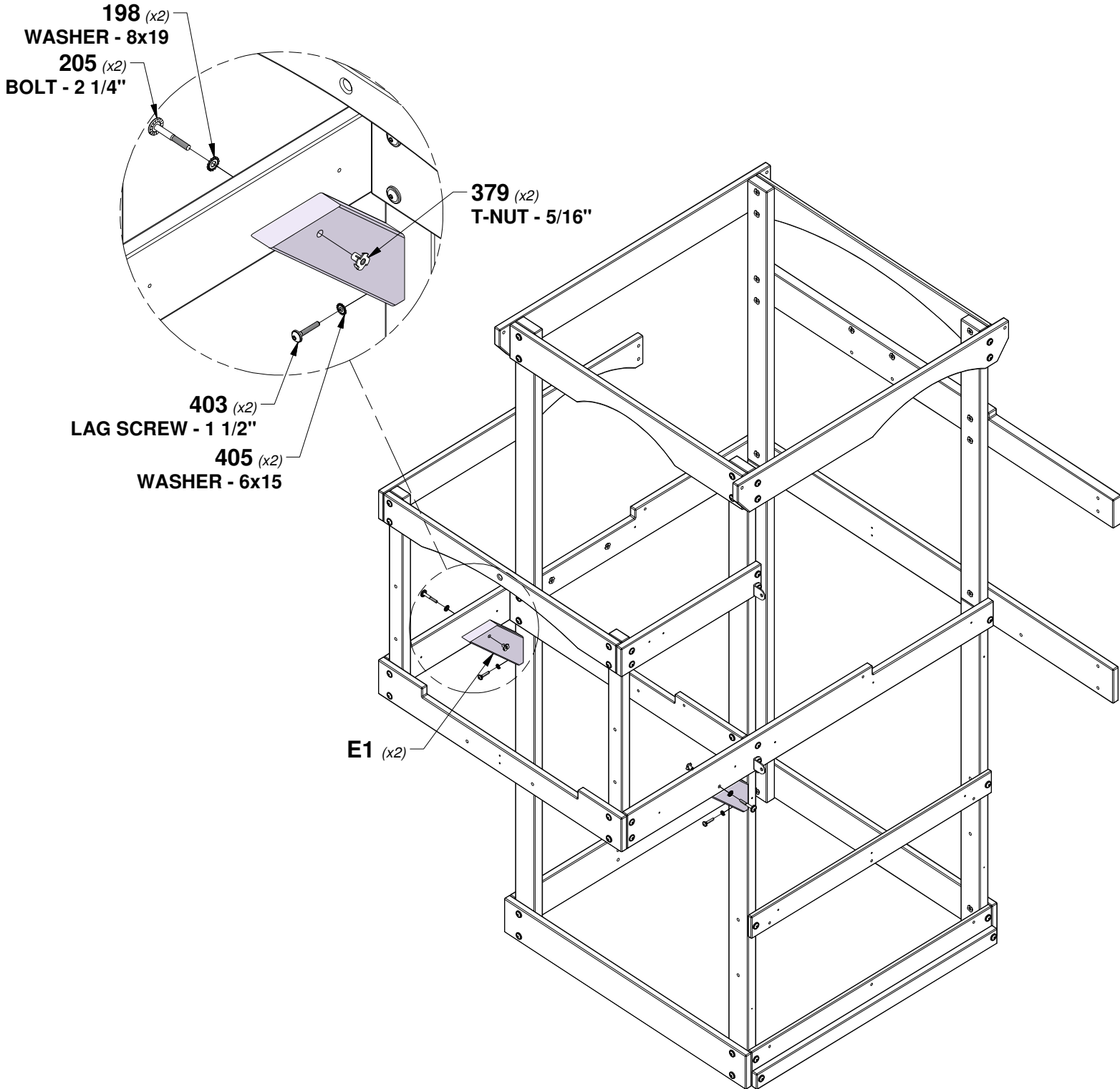

STEP 10 - FORT ASSEMBLY

QTY	PART NUMBER	DESCRIPTION
2	H100192	NUT BARREL WH 5/16x7/8 BLK
2	H100199	WASHER LOCK EXT 12x19 BLK
4	H100382	SCREW PFH 8x1 3/4 BLK
2	H100396	BOLT WH 5/16x1/2 BLK

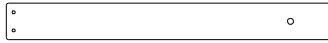

J10 PORCH GROUND BOARD - W4L17650
(x2) 1"x2 3/8"x21 1/8" (24x60x537)



G9 LEFT BALCONY WALL RAIL - W4L17648
(x1) 1"x5 1/4"x20 3/4" (24x134x528)

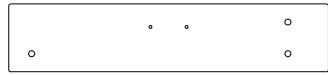

Q5 WALL RAIL - W4L17655
(x1) 1"x4 3/8"x20 7/8" (24x112x529)

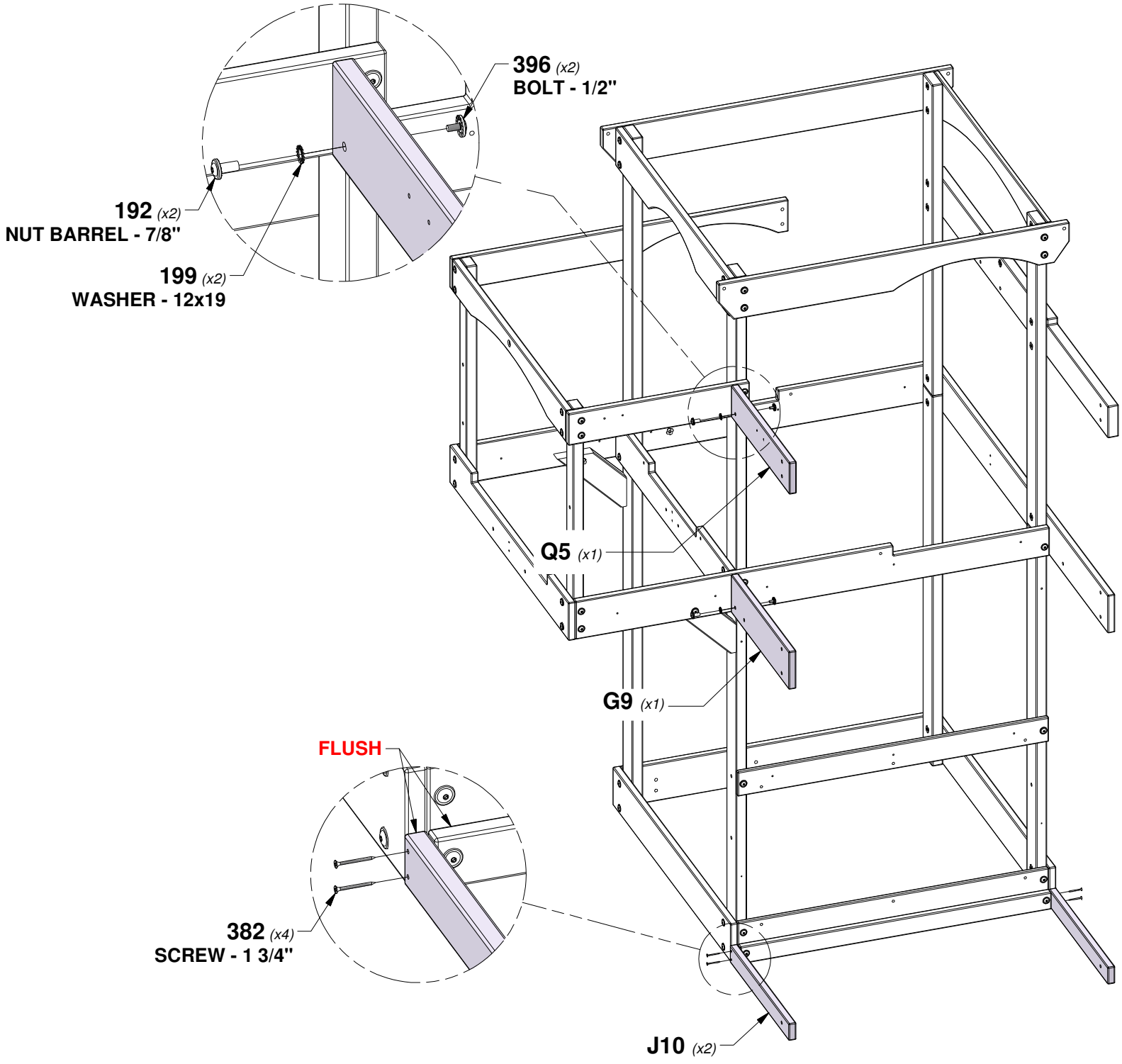

STEP 11 - FORT ASSEMBLY

QTY	PART NUMBER	DESCRIPTION
2	H100195	BOLT WH 5/16x2-3/4 BLK
10	H100198	WASHER LOCK EXT 8x19 BLK
8	H100205	BOLT WH 5/16x2-1/4 BLK
10	H100379	T-NUT 5/16 BLK



E5 RIGHT FRONT BALCONY UPRIGHT - W4L17826
 (x1) 1 3/8"x3 3/8"x80 3/4" (36x86x2052)



E11 RIGHT FRONT BALCONY UPRIGHT - W4L17827
 (x1) 1 3/8"x3 3/8"x80 3/4" (36x86x2052)

TIP:
INSTALL T-NUTS IN WOOD FIRST

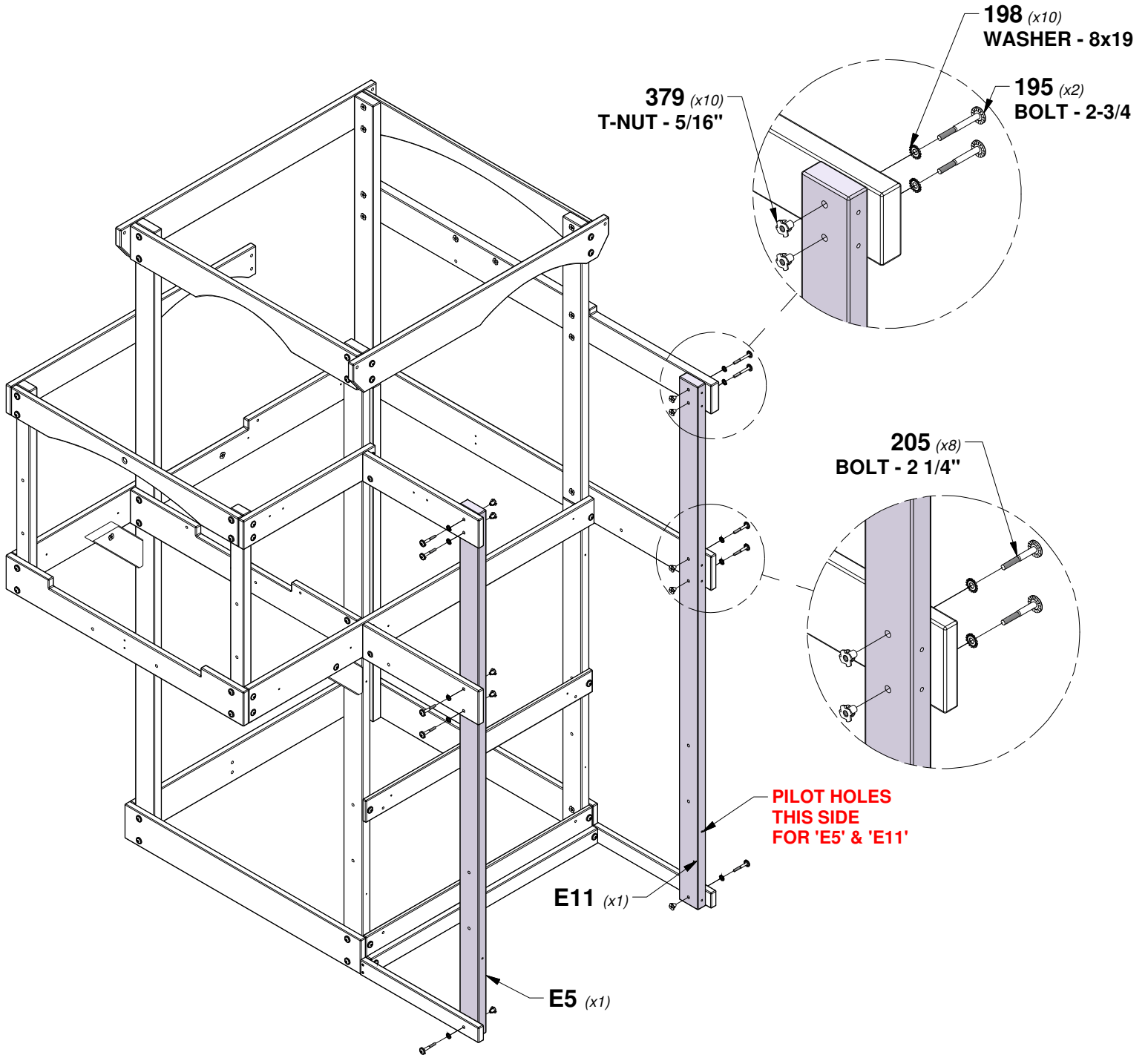

STEP 12 - FORT ASSEMBLY

QTY	PART NUMBER	DESCRIPTION
8	H100197	LAG SCREW WH 5/16x2-1/2 BLK
10	H100198	WASHER LOCK EXT 8x19 BLK
2	H100458	LAG SCREW WH 5/16x2 BLK

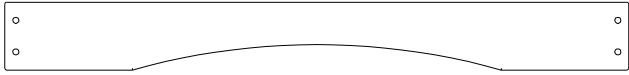

Q3 **ARCHED WALL RAIL - W4L17653**
 (x1) 1"x4 3/8"x40 5/8" (24x112x1032)

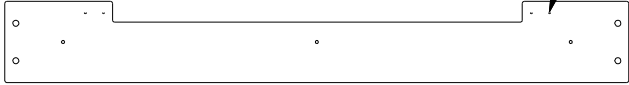

G10 **FRONT BALCONY WALL RAIL - W4L17649**
 (x1) 1"x5 1/4"x40 5/8" (24x134x1032)

PILOT HOLES INWARD WHEN INSTALLED

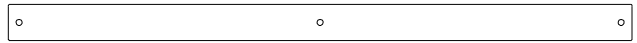

J2 **PORCH GROUND BOARD - W4L11129**
 (x1) 1"x2 3/8"x40 5/8" (24x60x1032)

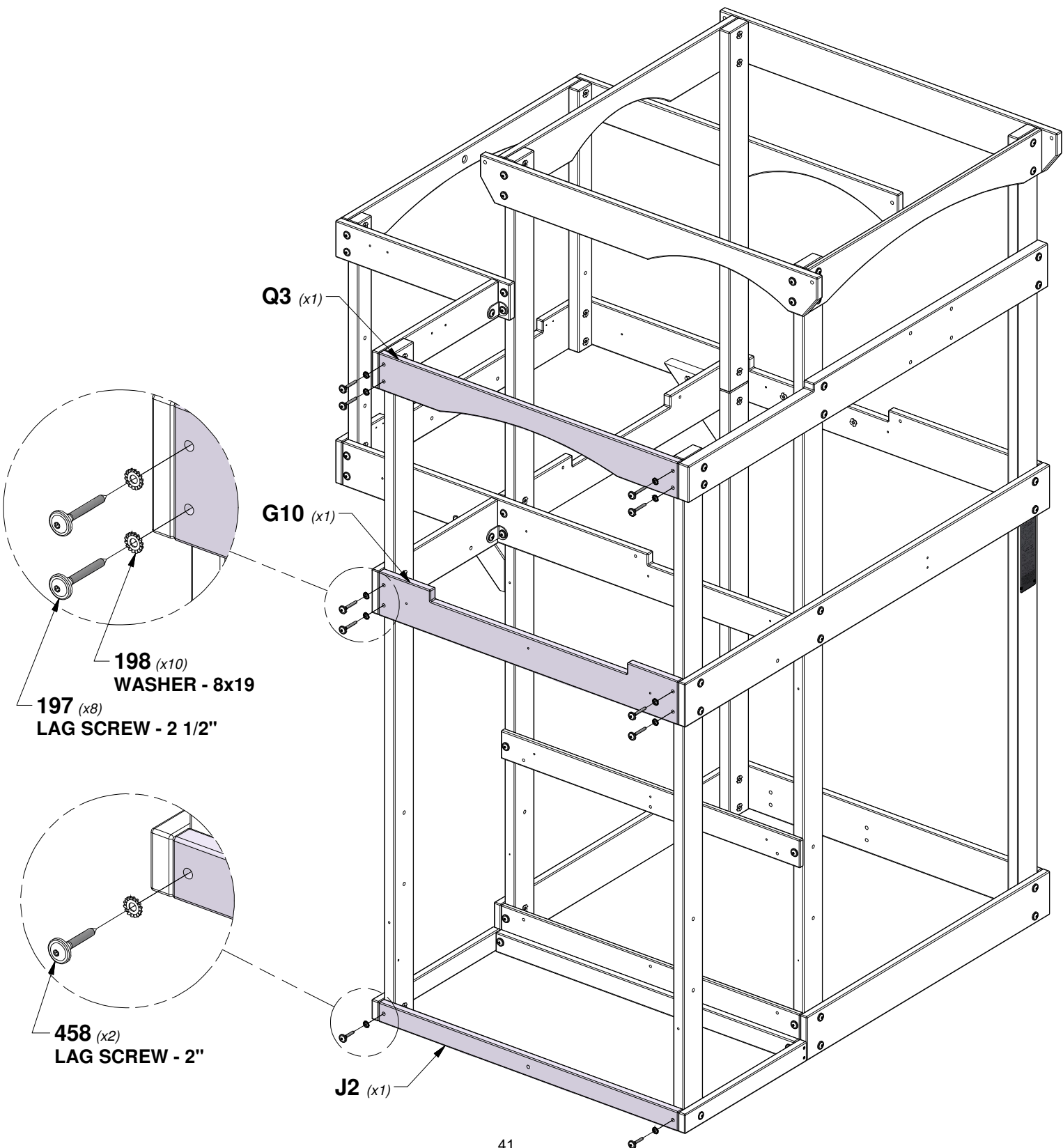

STEP 13 - FORT ASSEMBLY

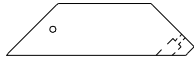

E1 DECK BRACE - W4L17821
 (x2) 1 3/8"x3 3/8"x12 1/4" (36x86x311)

QTY	PART NUMBER	DESCRIPTION
2	H100198	WASHER LOCK EXT 8x19 BLK
2	H100205	BOLT WH 5/16x2-1/4 BLK
2	H100379	T-NUT 5/16 BLK
2	H100403	LAG SCREW WH 1/4x1-1/2 BLK
2	H100405	WASHER LOCK EXT 6x15 BLK

TIP:
INSTALL T-NUTS IN WOOD FIRST

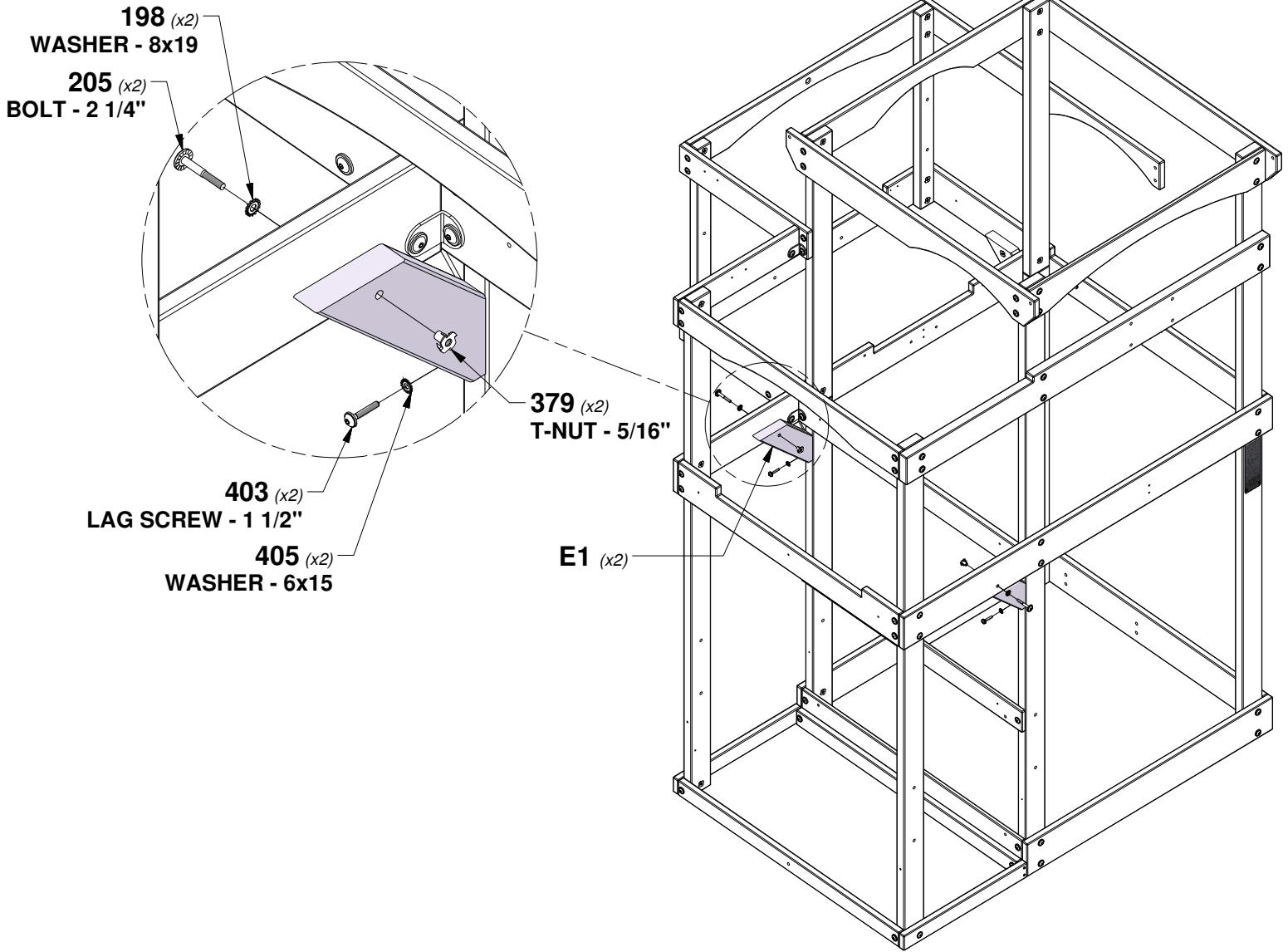

STEP 14 - FORT ASSEMBLY

QTY	PART NUMBER	DESCRIPTION
4	H100201	SCREW PFH 8x2-1/2 BLK
6	H100382	SCREW PFH 8x1 3/4 BLK



F06 FLOOR JOIST - W4L18510
 (x1) 1 3/8"x2"x40 1/2" (36x50x1030)



T01 SUPPORT BOARD - W4L18507
 (x2) 1"x1 3/8"x37 5/8" (24x34x957)

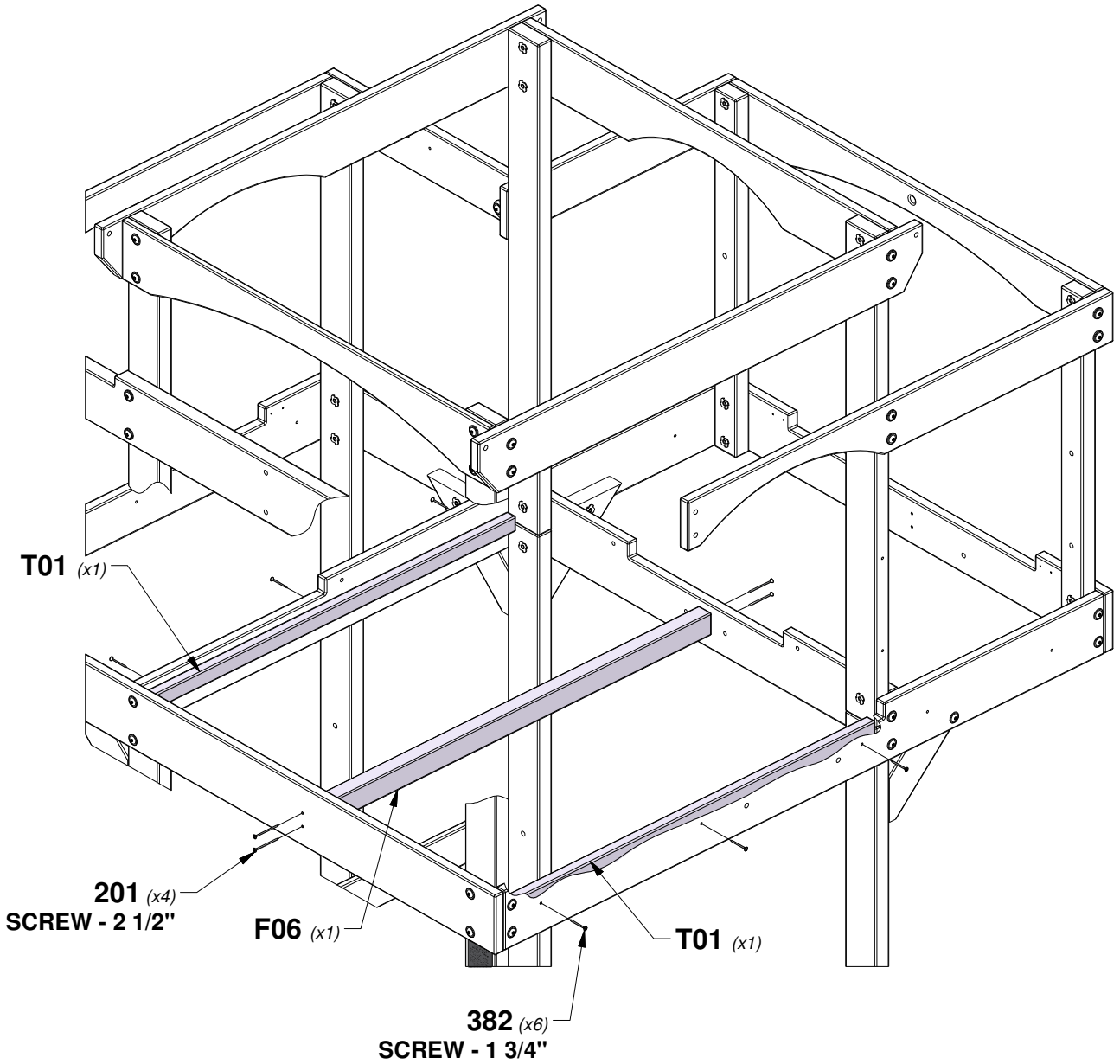
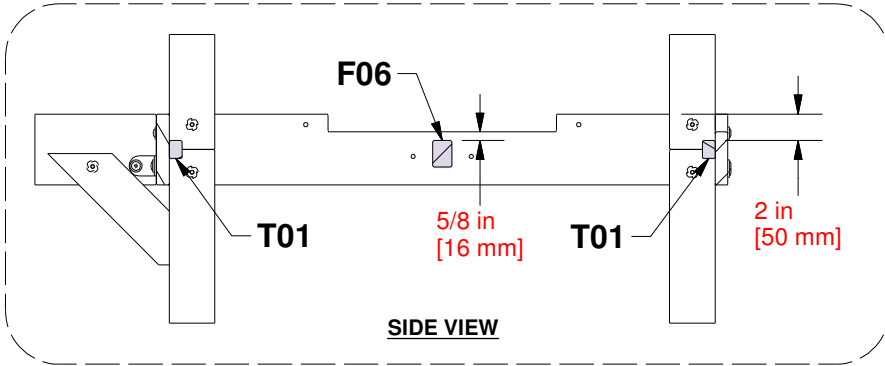

STEP 15 - FORT ASSEMBLY

QTY	PART NUMBER	DESCRIPTION
2	H100171	BOLT WH 1/4x1 BLK
2	H100201	SCREW PFH 8x2-1/2 BLK
4	H100382	SCREW PFH 8x1 3/4 BLK
2	H100398	T-NUT 1/4 BLK
1	H100399	NUT BARREL WH 1/4x7/8 BLK
1	H100401	BOLT WH 1/4x1/2 BLK



J09 FLOOR JOIST - W4L18527
 (x1) 1"x2 3/8"x20 1/4" (24x60x515)

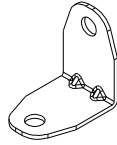

A4M01047 L BRACKET
 (x2) 2.5x38x55x55



T03 SUPPORT BOARD - W4L18509
 (x2) 1"x1 3/8"x18 3/4" (24x34x477)

TIP:
INSTALL T-NUTS IN WOOD FIRST

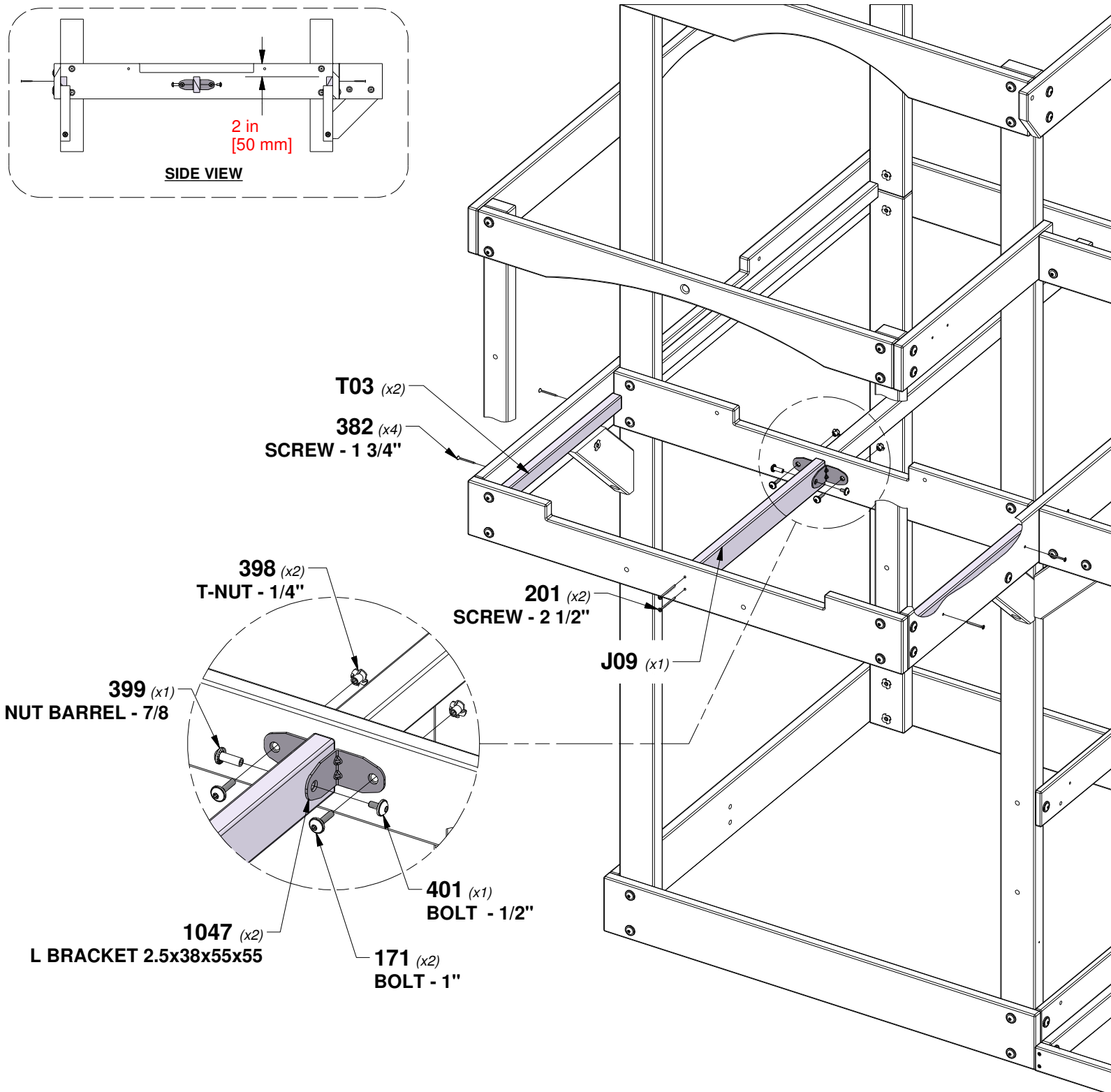
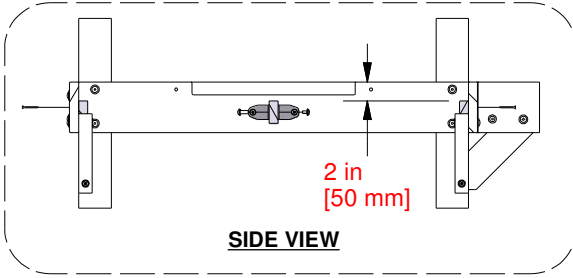

STEP 16 - FORT ASSEMBLY

QTY	PART NUMBER	DESCRIPTION
56	H100200	SCREW PFH 8x1-1/2 BLK



M11 FLOOR BOARD - W4L18522
(x10) 5/8"x3 3/8"x40 5/8" (16x86x1031)

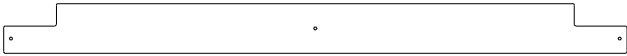

M12 FLOOR BOARD - W4L18528
(x2) 5/8"x3 1/4"x40 5/8" (16x82x1031)

TIP:
PLACE BOARDS EVENLY
BEFORE INSERTING SCREWS

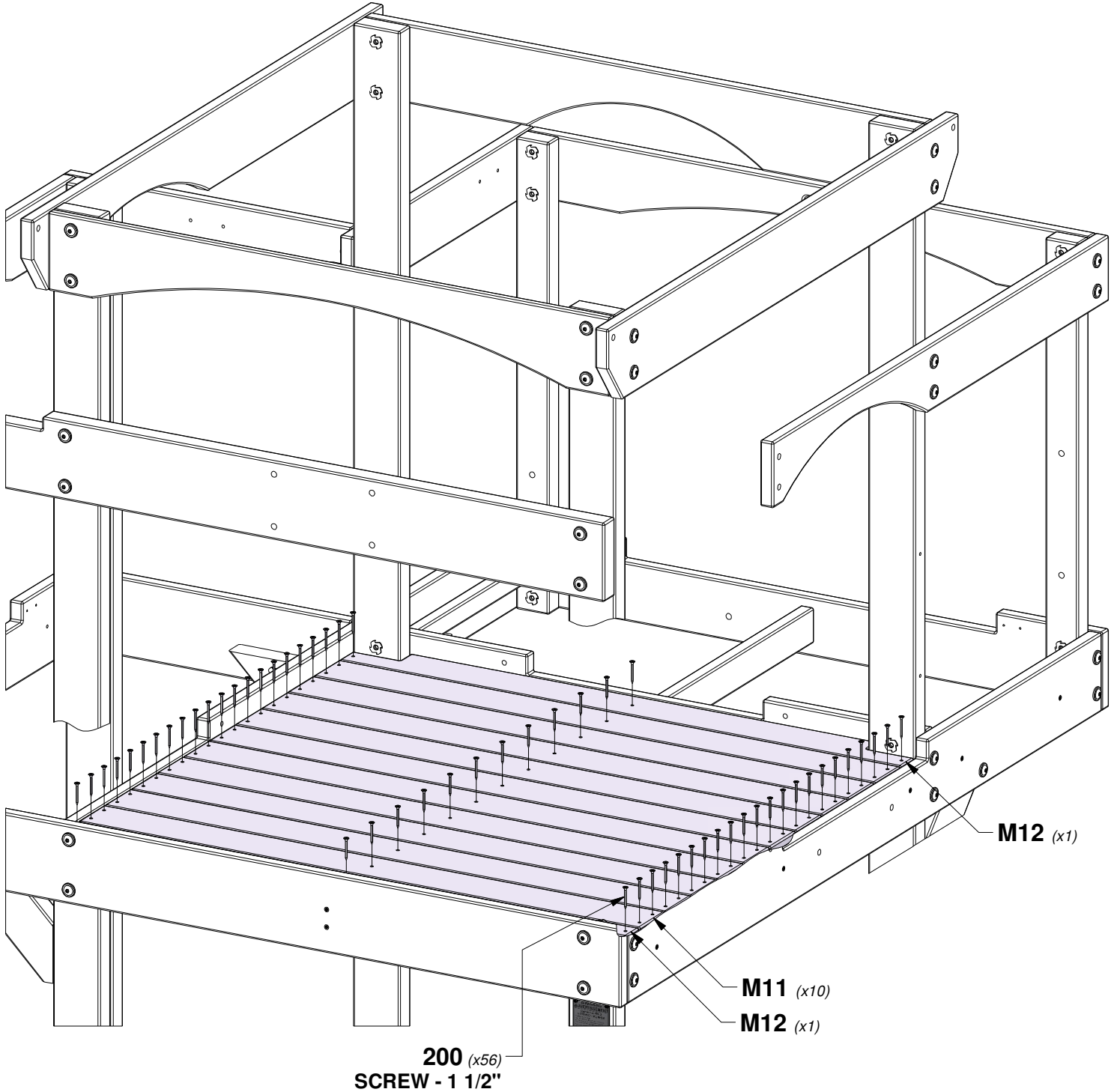

STEP 17 - FORT ASSEMBLY

QTY	PART NUMBER	DESCRIPTION
28	H100200	SCREW PFH 8x1-1/2 BLK

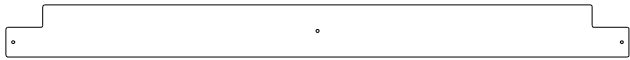

M10 FLOOR BOARD - W4L18513
(x1) 5/8"x3 3/8"x40 5/8" (16x86x1031)

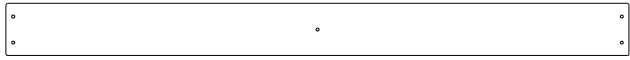

M11 FLOOR BOARD - W4L18522
(x5) 5/8"x3 3/8"x40 5/8" (16x86x1031)

TIP:
PLACE BOARDS EVENLY
BEFORE INSERTING SCREWS

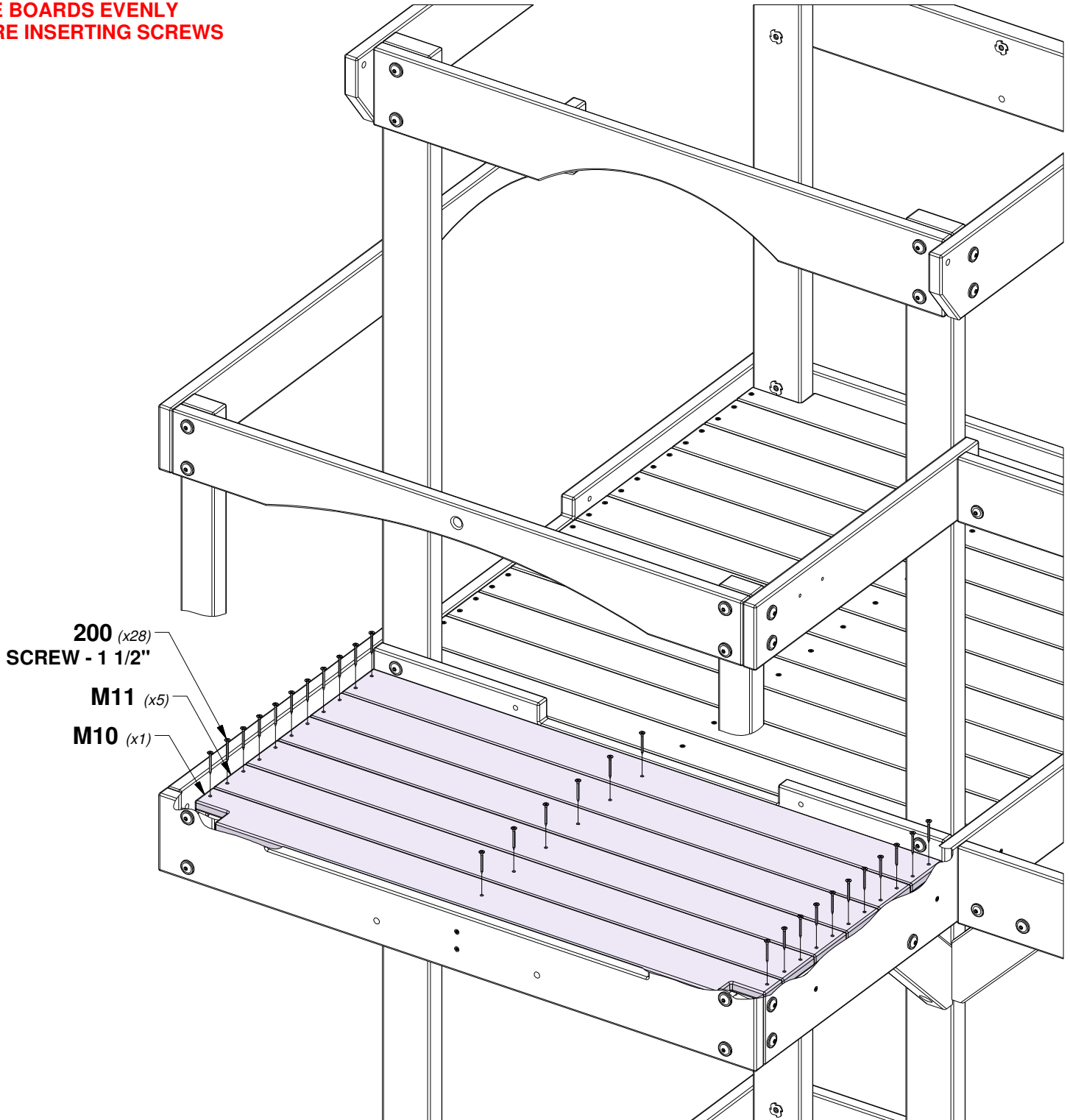

STEP 18 - FORT ASSEMBLY

QTY	PART NUMBER	DESCRIPTION
6	H100382	SCREW PFH 8x1 3/4 BLK

T01 SUPPORT BOARD - W4L18507
 (x1) 1"x1 3/8"x37 5/8" (24x34x957)

T02 SUPPORT BOARD - W4L18508
 (x1) 1"x1 3/8"x37 3/4" (24x34x959)

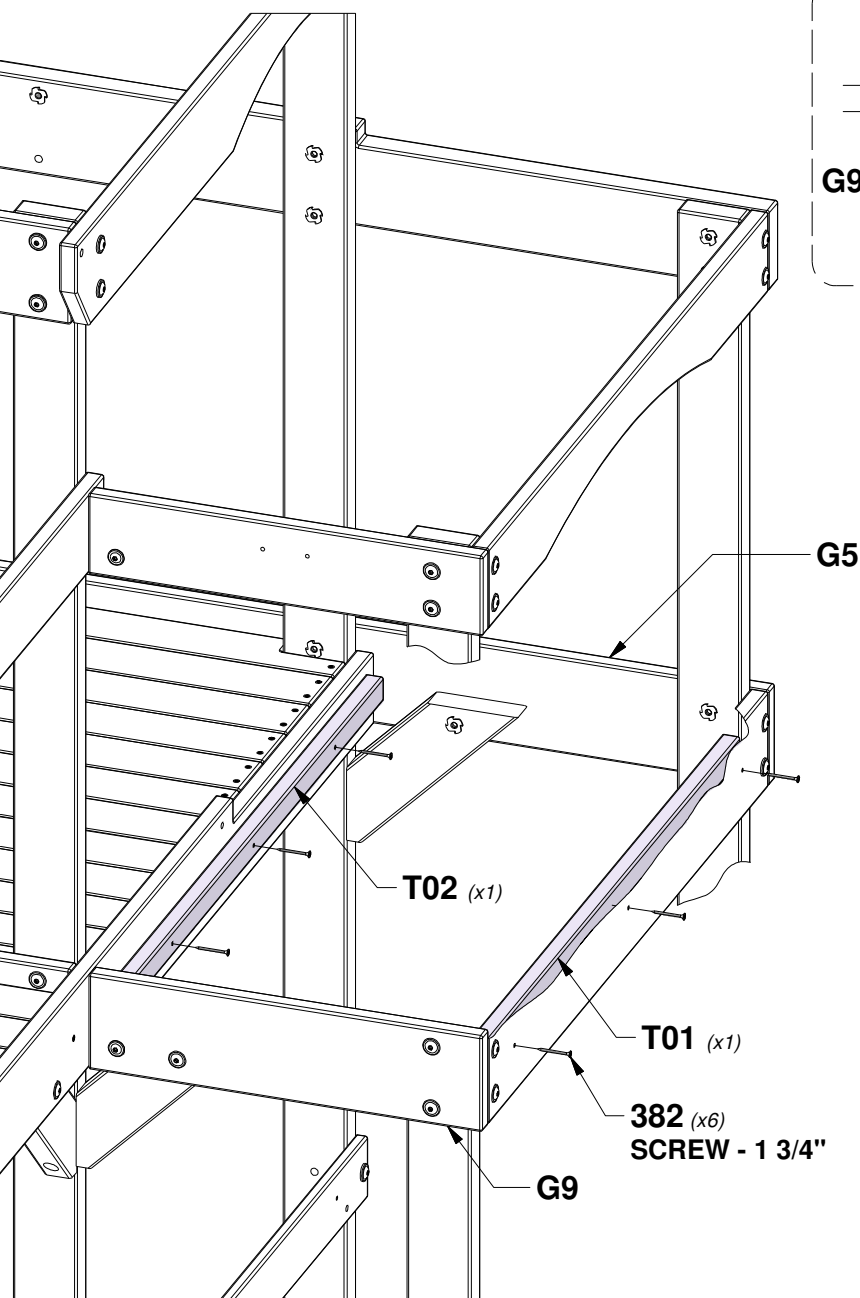
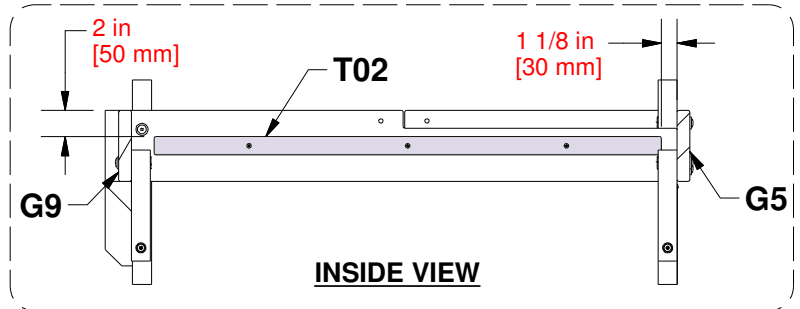
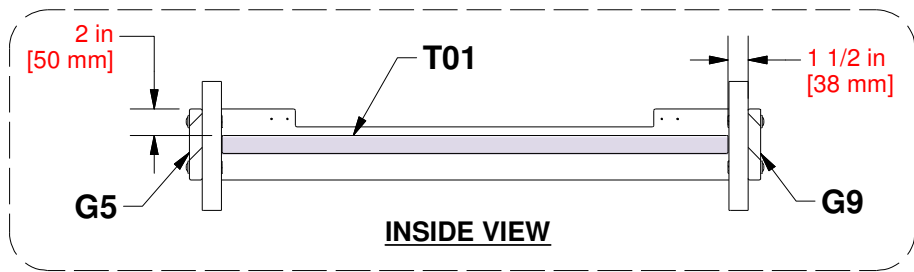

STEP 19 - FORT ASSEMBLY

QTY	PART NUMBER	DESCRIPTION
44	H100200	SCREW PFH 8x1-1/2 BLK



M08 FLOOR BOARD - W4L18526
(x1) 5/8"x3 1/4"x19 7/8" (16x82x504)



M09 FLOOR BOARD - W4L18521
(x10) 5/8"x3 3/8"x19 7/8" (16x86x504)



M13 FLOOR BOARD - W4L18525
(x1) 5/8"x3 1/4"x19 7/8" (16x82x504)

TIP:
PLACE BOARDS EVENLY
BEFORE INSERTING SCREWS

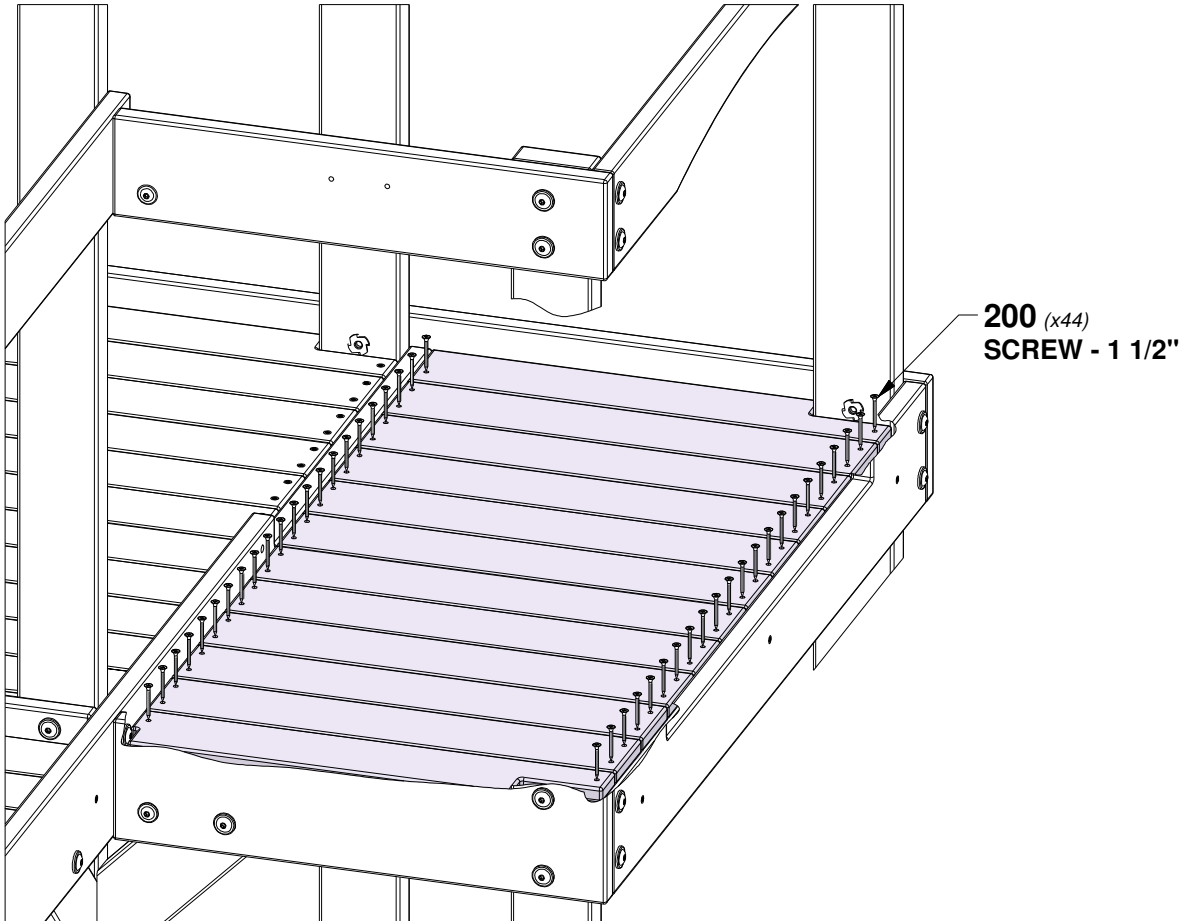
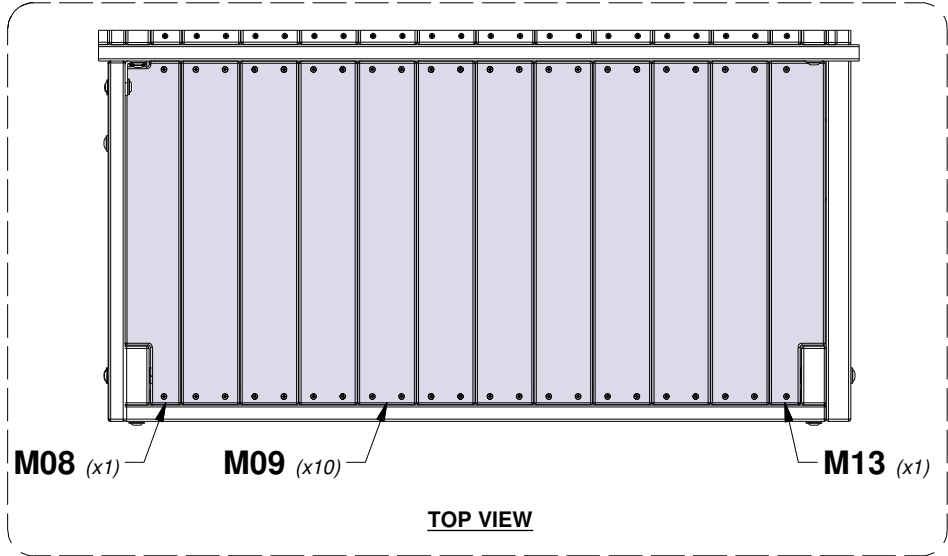

STEP 20 - FORT ASSEMBLY

QTY	PART NUMBER	DESCRIPTION
6	H100398	T-NUT 1/4 BLK
6	H100405	WASHER LOCK EXT 6x15 BLK
6	H100406	BOLT WH 1/4x1 1/2 BLK

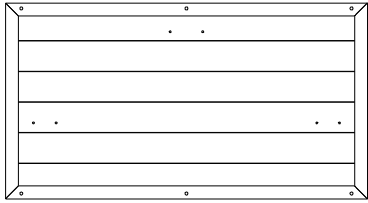

WP01 WALL PANEL - W2A03778
 (x1) 1"x20 3/8"x37 3/4" (24x517x958)

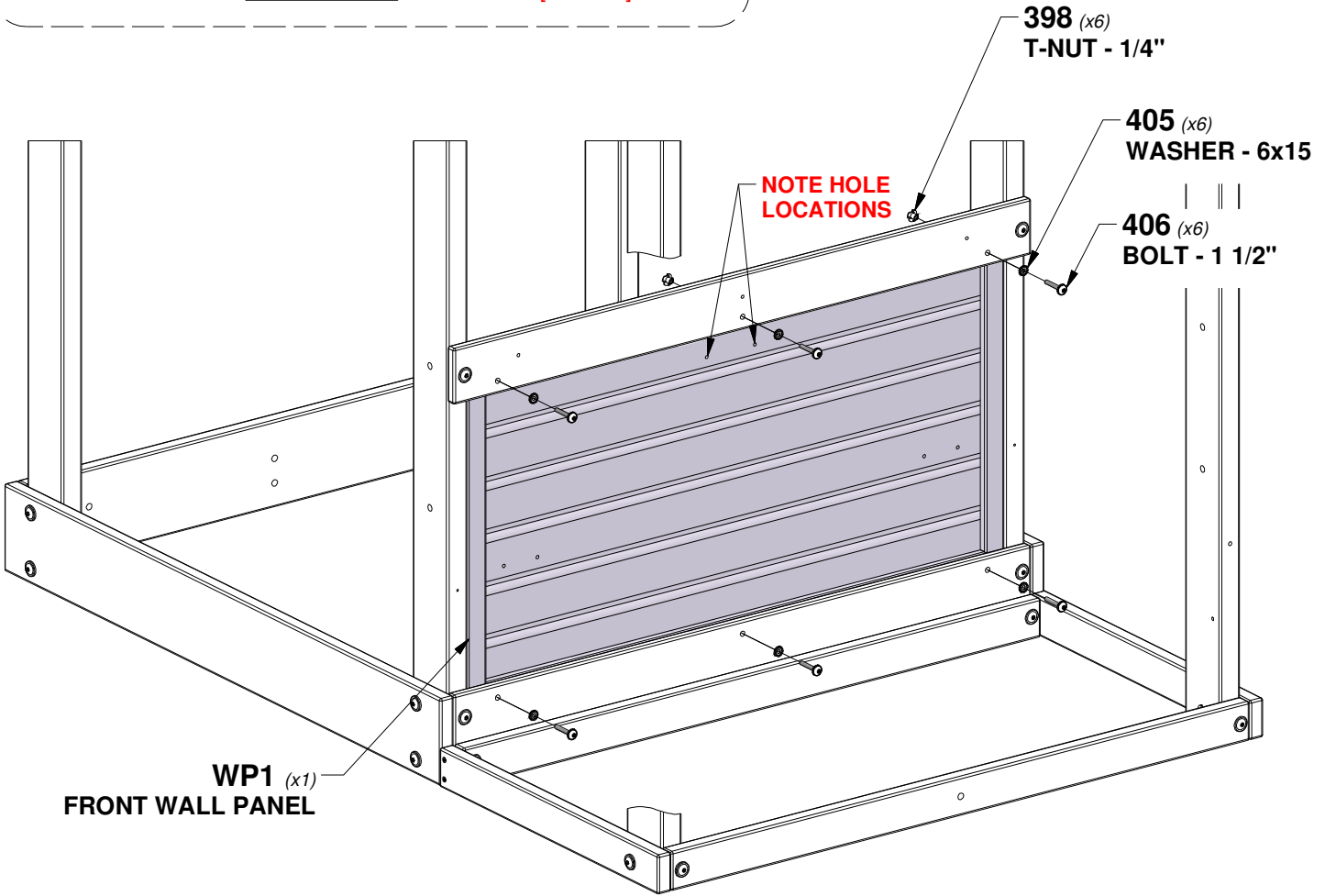
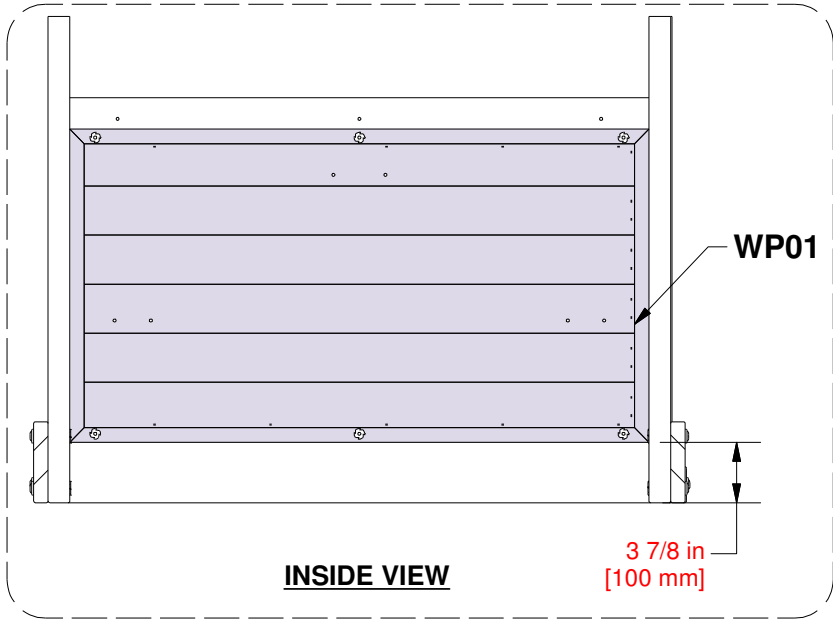

STEP 21 - FORT ASSEMBLY

QTY	PART NUMBER	DESCRIPTION
3	H100387	SCREW PFH 8x1-1/4 BLK

T04 SUPPORT BOARD - W4L18515
(x1) 1"x1 3/8"x37 3/4" (24x34x958)

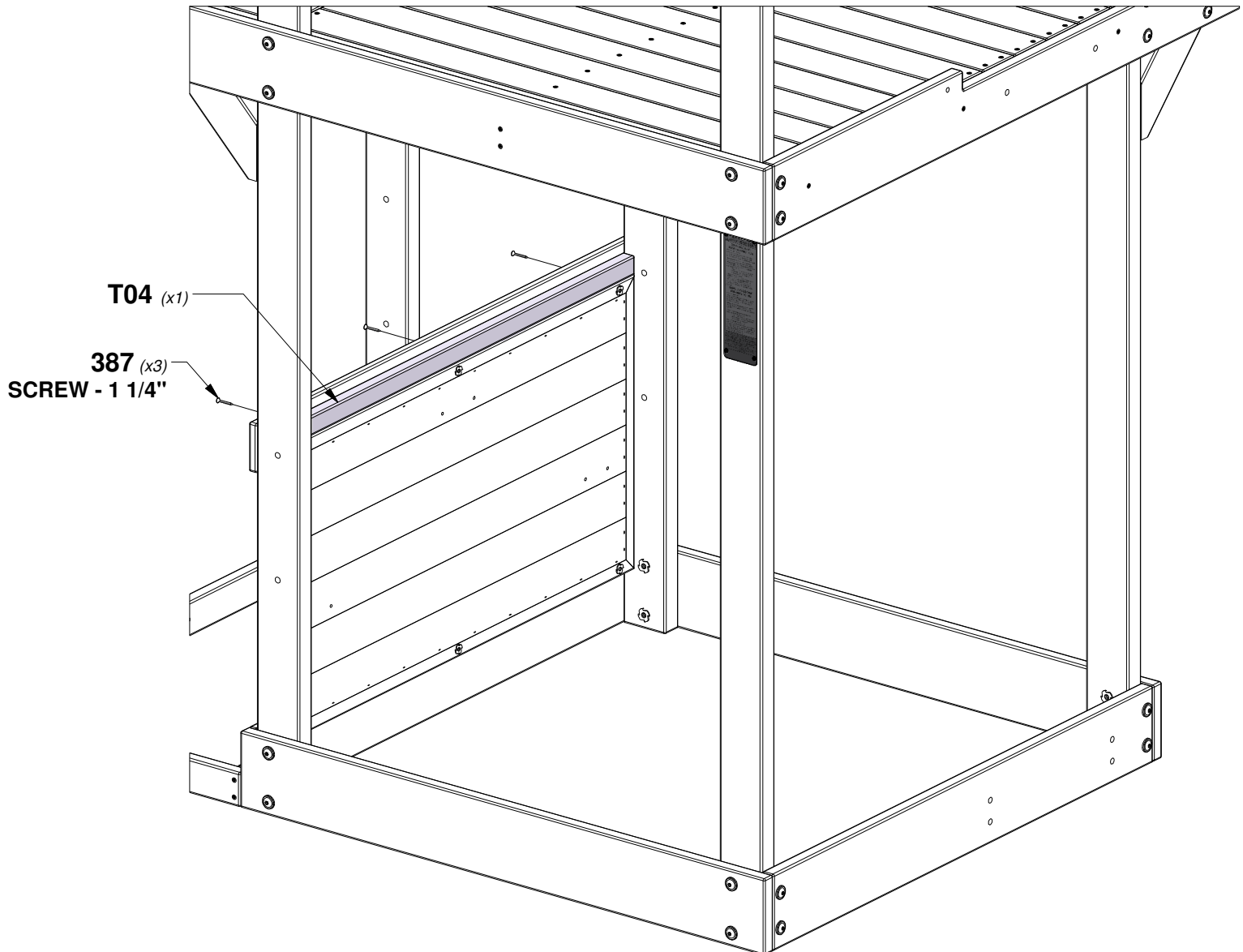

STEP 22 - FORT ASSEMBLY

QTY	PART NUMBER	DESCRIPTION
4	H100387	SCREW PFH 8x1-1/4 BLK

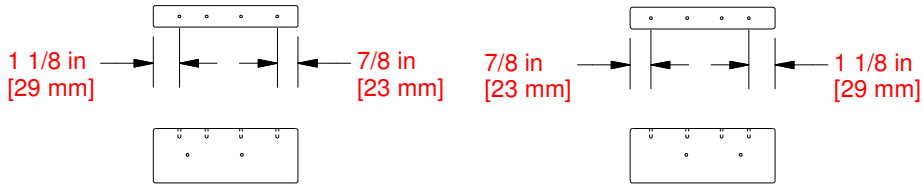

J6 SUPPORT BLOCK - W4L17817
(x1) 1"x2 3/8"x6 1/4" (24x60x160)

J11 SUPPORT BLOCK - W4L17818
(x1) 1"x2 3/8"x6 1/4" (24x60x160)

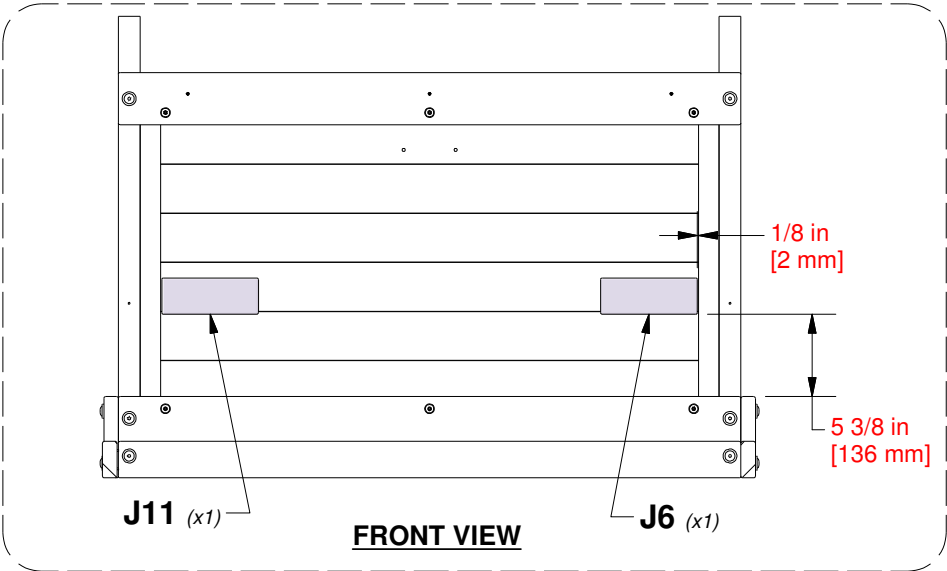

TIP:
ALIGN PILOT HOLES IN WALL PANEL TO
PILOT HOLES IN (J) BOARDS.

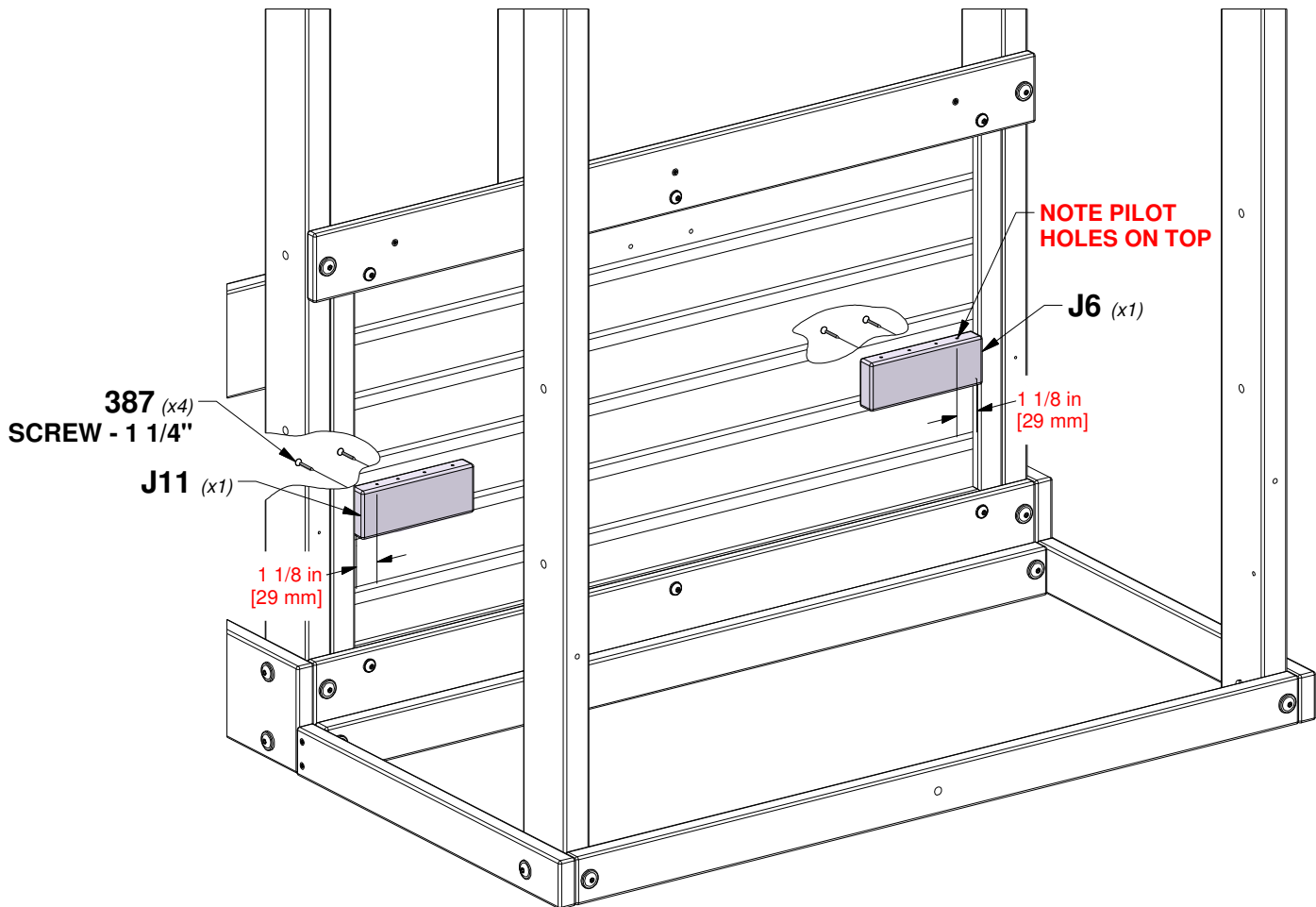

STEP 23 - FORT ASSEMBLY

QTY	PART NUMBER	DESCRIPTION
1	H100195	BOLT WH 5/16x2-3/4 BLK
1	H100198	WASHER LOCK EXT 8x19 BLK
1	H100379	T-NUT 5/16 BLK



H1 TABLE SUPPORT - W4L11147
 (x1) 1"x3 3/8"x22 3/8" (24x86x567)

J7 SUPPORT BLOCK - W4L11158
 (x1) 1"x2 3/8"x3 3/8" (24x60x86)

TIP:
INSTALL T-NUTS IN WOOD FIRST

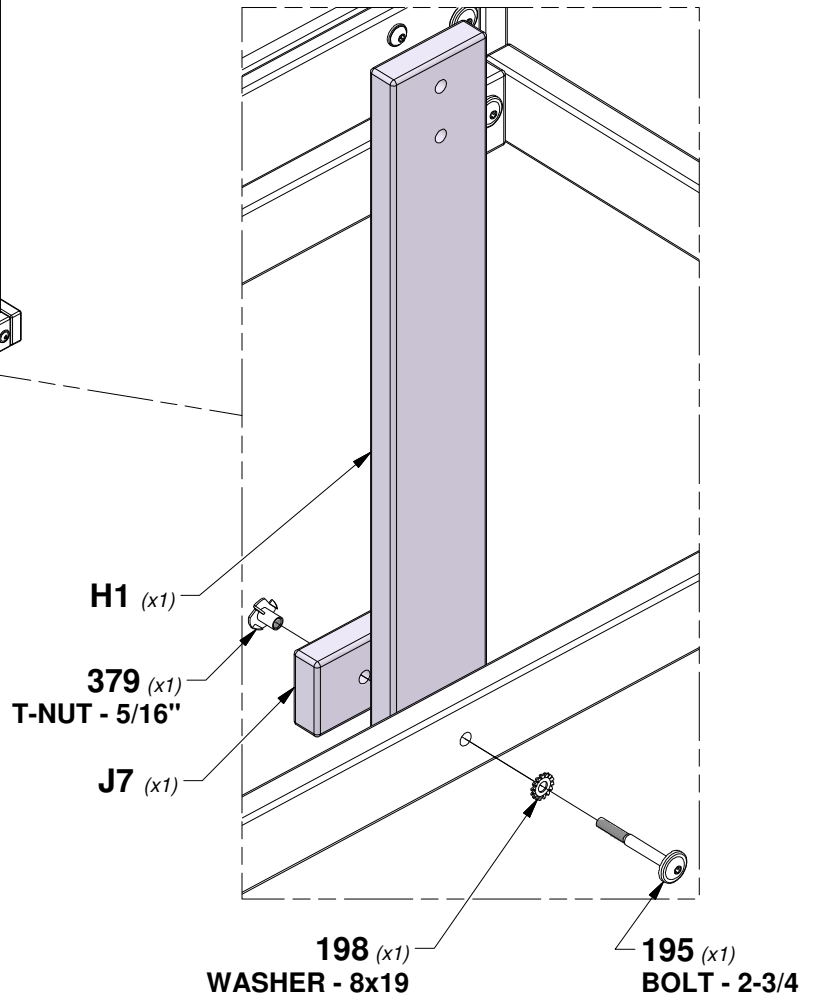
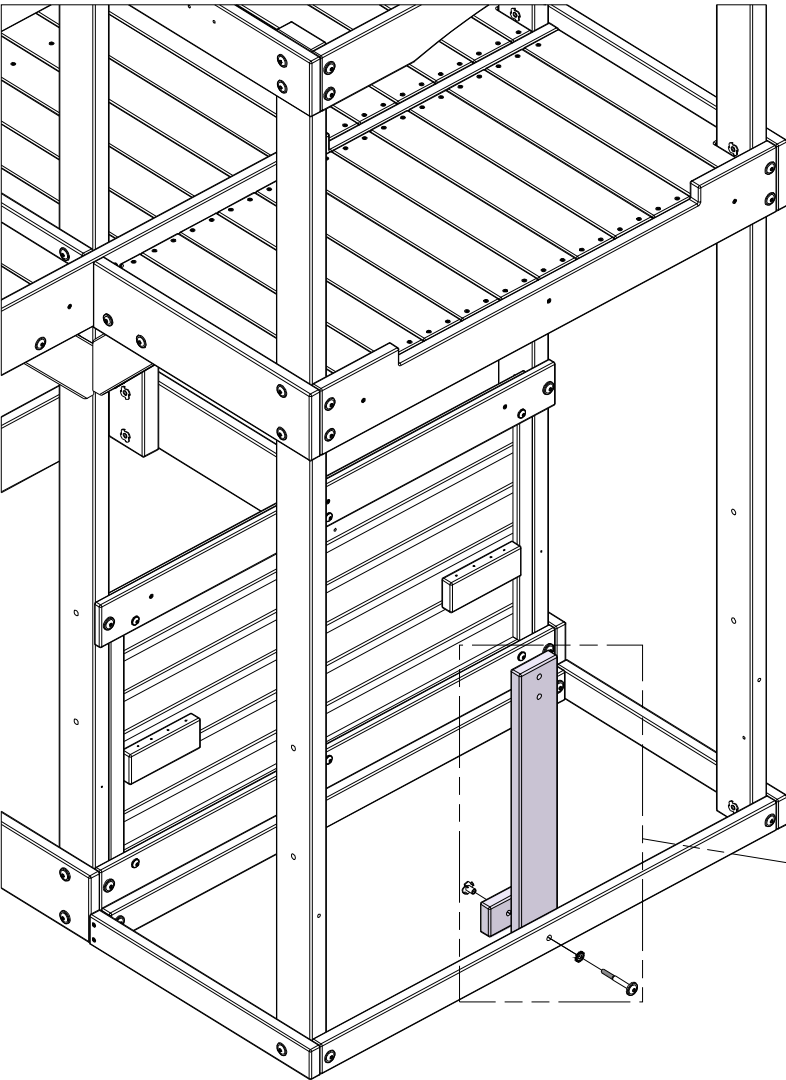

STEP 24 - FORT ASSEMBLY

QTY	PART NUMBER	DESCRIPTION
42	H100200	SCREW PFH 8x1-1/2 BLK

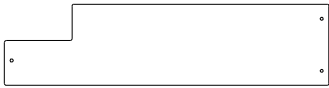

K17 FLOOR BOARD - W4L18523
(x2) 5/8"x5 1/4"x21 1/8" (16x134x537)

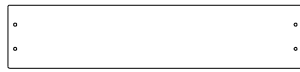

L05 FLOOR BOARD - W4L18524
(x1) 5/8"x4 1/8"x19 1/4" (16x104x488)



M04 FLOOR BOARD - W4L18506
(x8) 5/8"x3 3/8"x21 1/8" (16x86x537)

TIP:
PLACE BOARDS EVENLY
BEFORE INSERTING SCREWS

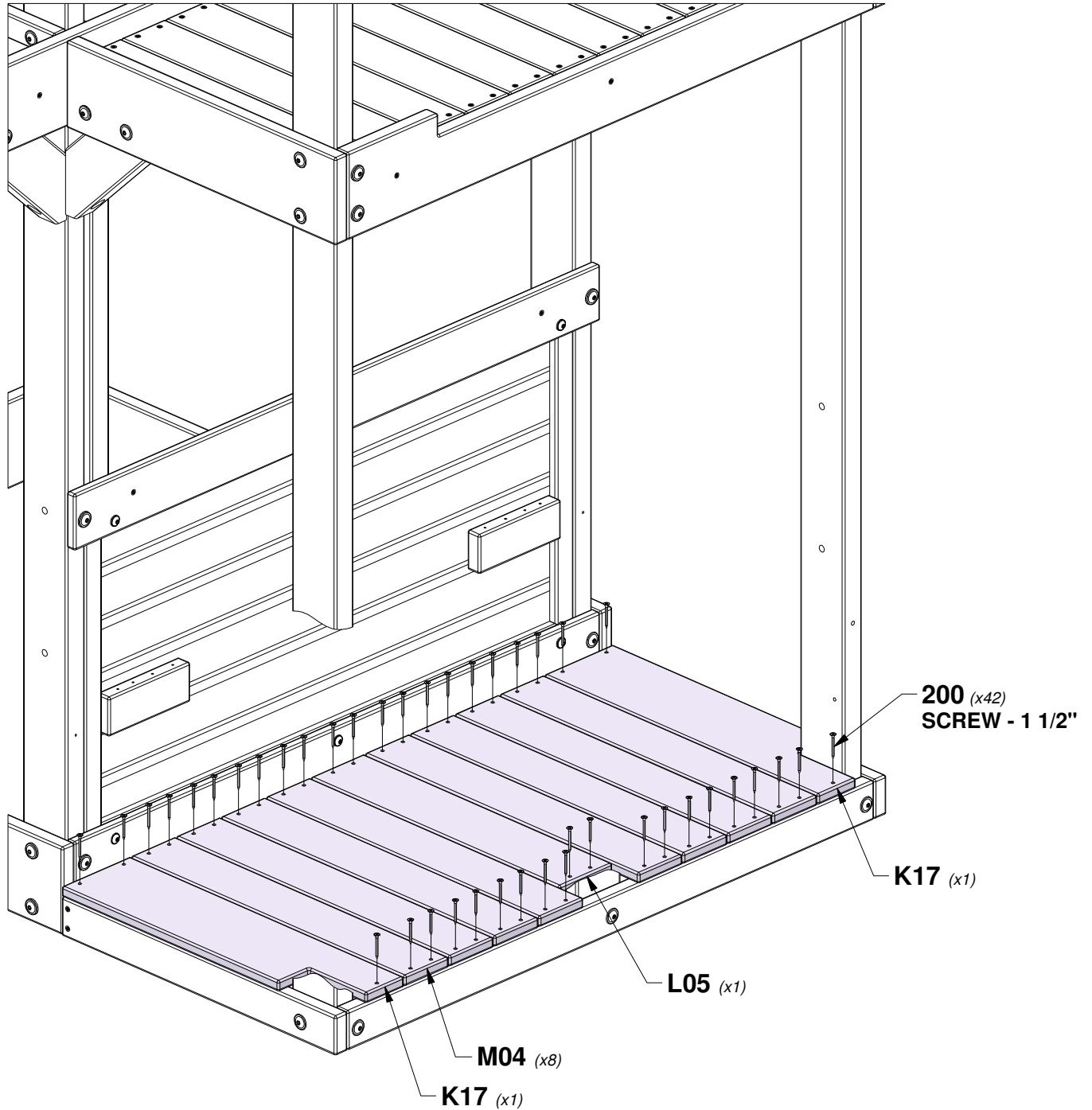

STEP 25 - FORT ASSEMBLY

QTY	PART NUMBER	DESCRIPTION
4	H100198	WASHER LOCK EXT 8x19 BLK
2	H100205	BOLT WH 5/16x2-1/4 BLK
2	H100379	T-NUT 5/16 BLK
4	H100382	SCREW PFH 8x1 3/4 BLK
2	H100405	WASHER LOCK EXT 6x15 BLK
2	H100458	LAG SCREW WH 5/16x2 BLK
2	H100487	LAG SCREW WH 1/4x2 BLK

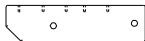

J3 BENCH SUPPORT - W4L18017
(x2) 1"x2 3/8"x9" (24x60x230)



J5 SUPPORT BLOCK - W4L18022
(x2) 1"x2 3/8"x2 7/8" (24x60x72)

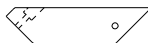

F5 ANGLE BRACE - W4L17822
(x2) 1 3/8"x2 3/8"x9 1/2" (36x60x240)

TIP:
INSTALL T-NUTS IN WOOD FIRST

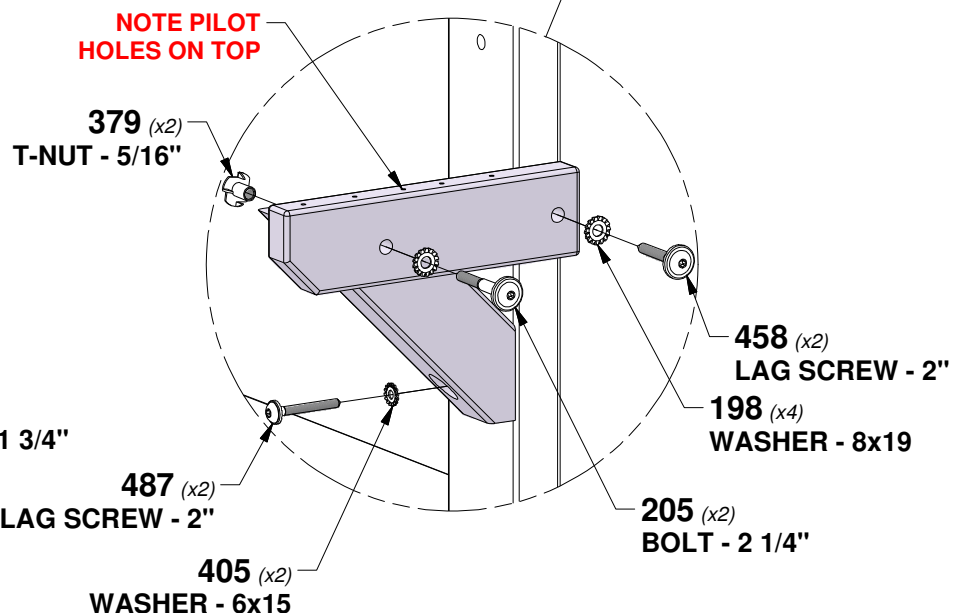
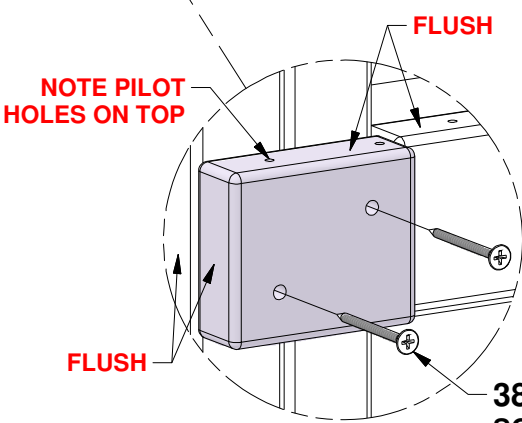
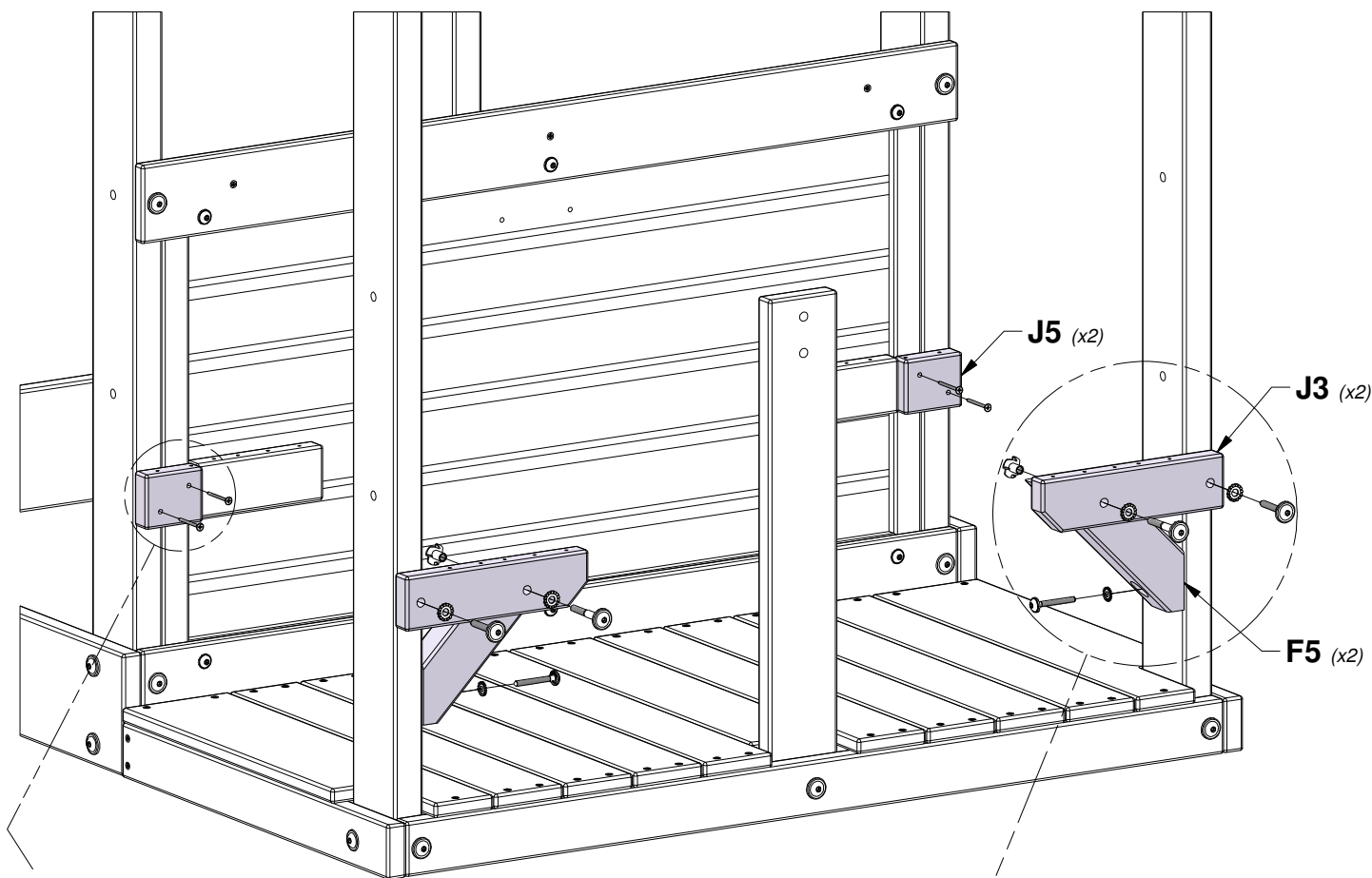

STEP 26 - FORT ASSEMBLY

QTY	PART NUMBER	DESCRIPTION
22	H100382	SCREW PFH 8x1 3/4 BLK

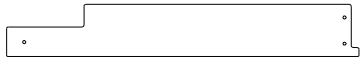

H06 BENCH BOARD - W4L18518
(x2) 1"x3 3/8"x23" (24x86x583)



H07 BENCH BOARD - W4L18519
(x2) 1"x2 3/8"x23" (24x60x583)



H08 BENCH BOARD - W4L18520
(x2) 1"x3 3/8"x23" (24x86x583)

TIP:
ALIGN PILOT HOLES BEFORE INSERTING SCREWS

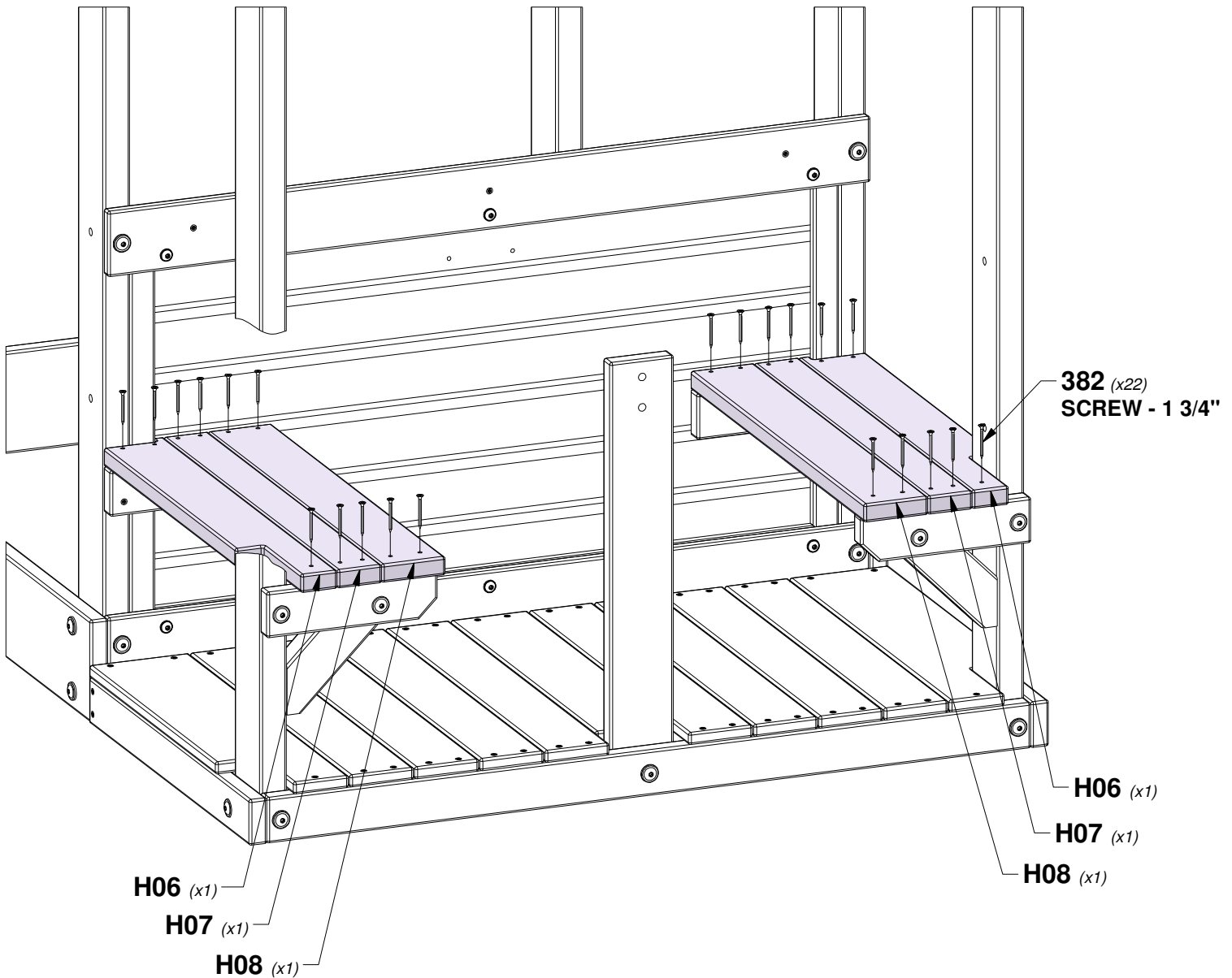

STEP 27 - FORT ASSEMBLY

QTY	PART NUMBER	DESCRIPTION
12	H100200	SCREW PFH 8x1-1/2 BLK
2	H100387	SCREW PFH 8x1-1/4 BLK
2	H100198	WASHER LOCK EXT 8x19 BLK
2	H100378	BOLT WH 5/16x1 3/4 BLK
2	H100379	T-NUT 5/16 BLK

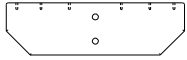

H2 TABLE SUPPORT - W4L18018
(x1) 1"x3 3/8"x11 5/8" (24x86x295)

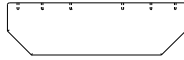

H3 TABLE SUPPORT - W4L18021
(x1) 1"x3 3/8"x11 5/8" (24x86x295)



K16 TABLE BOARD - W4L18530
(x1) 5/8"x5 1/4"x23" (16x134x583)



M03 BENCH BOARD - W4L18529
(x2) 5/8"x3 3/8"x23" (16x86x583)

TIP:
INSTALL T-NUTS IN WOOD FIRST.
ALIGN PILOT HOLES.

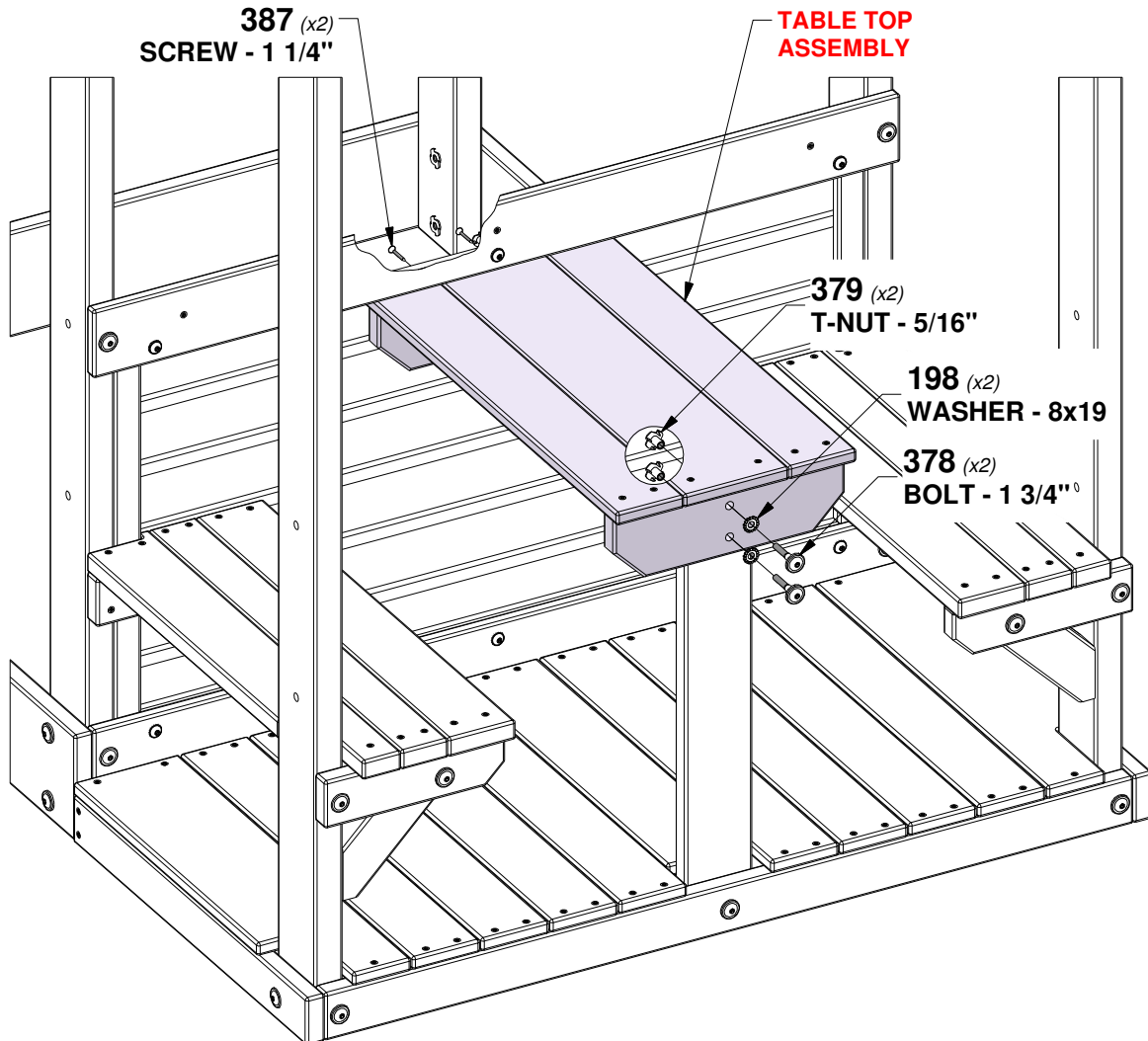
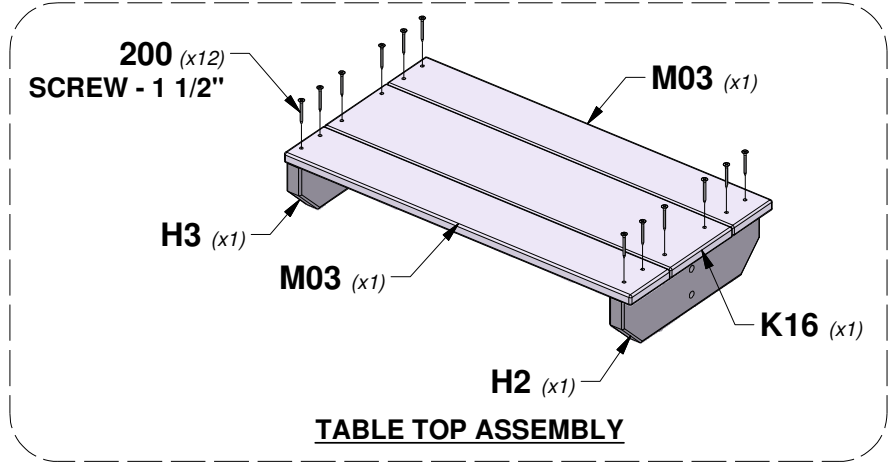

STEP 28 - FORT ASSEMBLY

QTY	PART NUMBER	DESCRIPTION
8	H100382	SCREW PFH 8x1 3/4 BLK

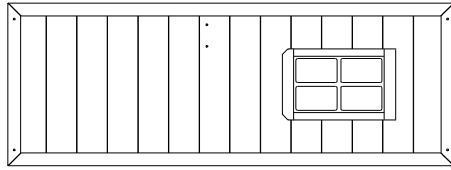
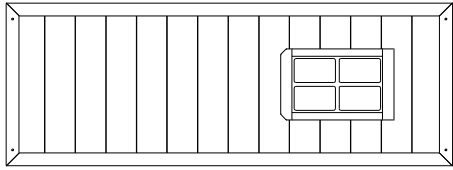

WP02 WALL PANEL - W2A03779

(x1) 1"x16 7/8"x46 1/2" (24x430x1181)

WP11 WALL PANEL - W2A03788

(x1) 1"x16 7/8"x46 1/2" (24x430x1181)

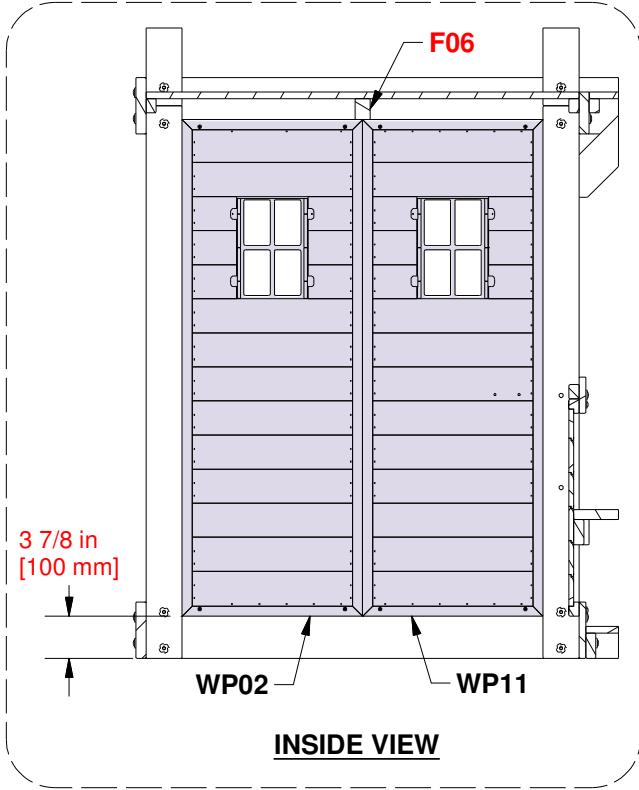

FLUSH TOP OF PANELS TO BOTTOM OF (F06)

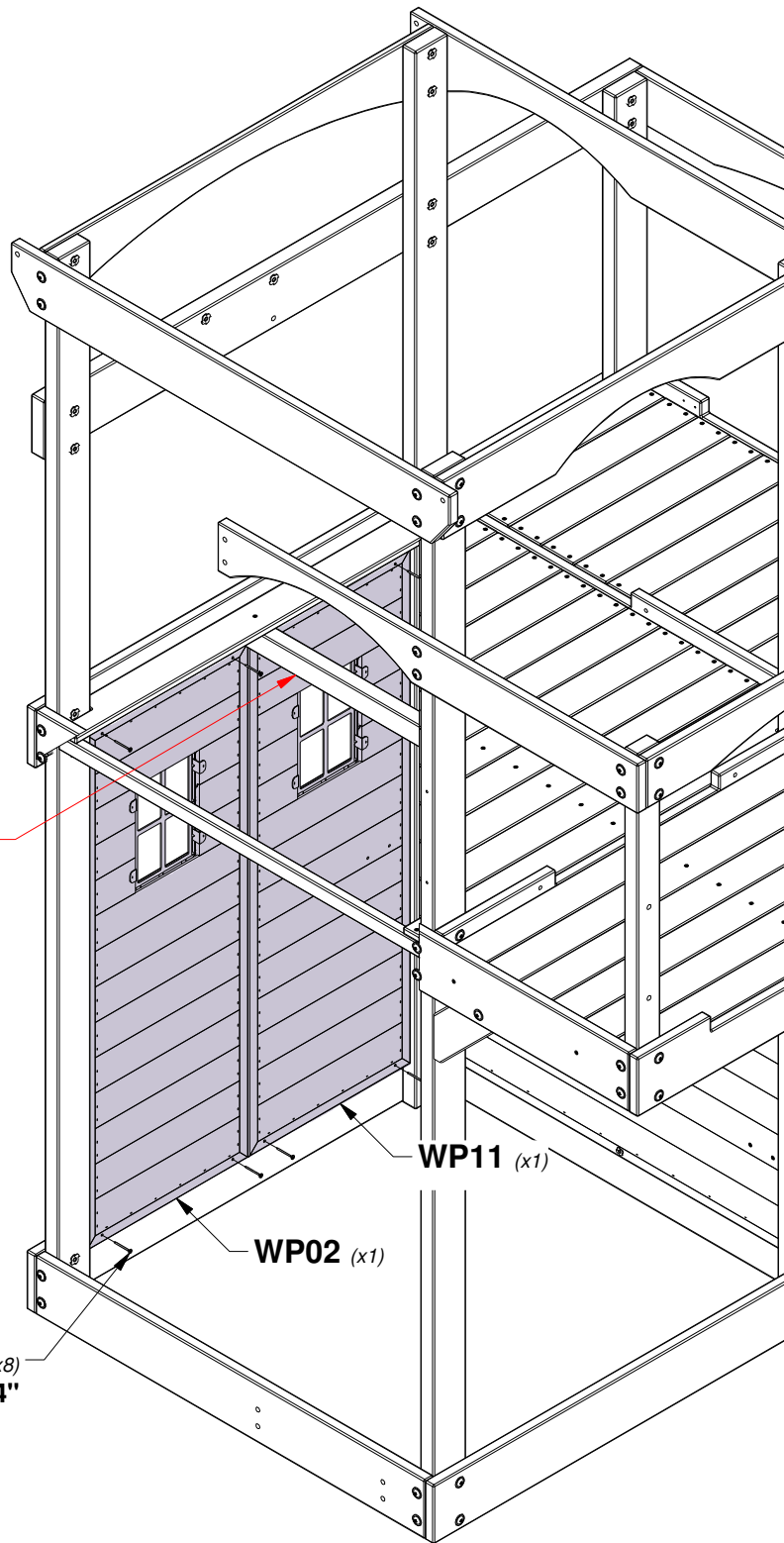

STEP 29 - FORT ASSEMBLY

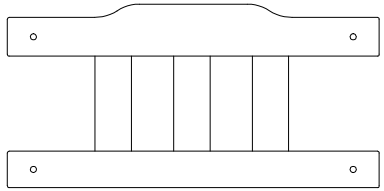

WP10 BENCH BACK ASSEMBLY - W2A037777
 (x1) 1 1/8"x11 7/8"x24 1/4" (27x303x615)

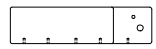

F03 SUPPORT BLOCK - W4L18516
 (x1) 1 3/8"x2 3/8"x9 1/4" (36x60x234)

QTY	PART NUMBER	DESCRIPTION
1	H100195	BOLT WH 5/16x2-3/4 BLK
4	H100198	WASHER LOCK EXT 8x19 BLK
3	H100200	SCREW PFH 8x1-1/2 BLK
4	H100379	T-NUT 5/16 BLK
3	H100457	BOLT WH 5/16x2 BLK

TIP:
INSTALL T-NUTS IN WOOD FIRST

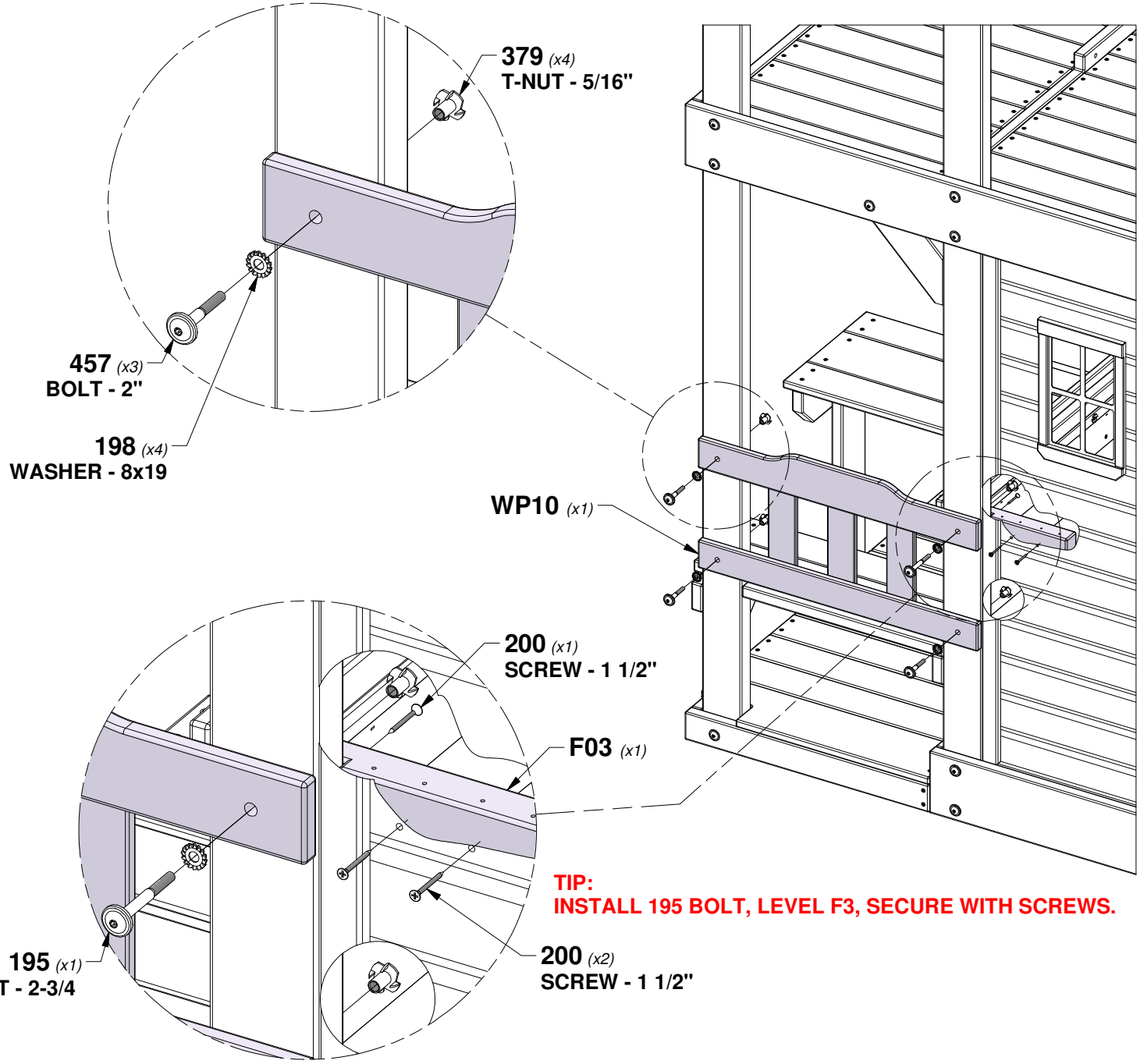

STEP 30 - FORT ASSEMBLY

QTY	PART NUMBER	DESCRIPTION
4	H100382	SCREW PFH 8x1 3/4 BLK

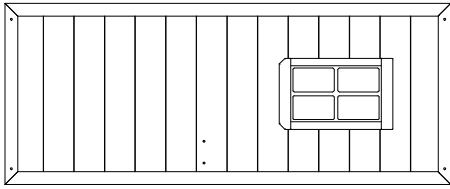

WP12 WALL PANEL - W2A03789
 (x1) 1"x16 7/8"x46 1/2" (24x479x1181)

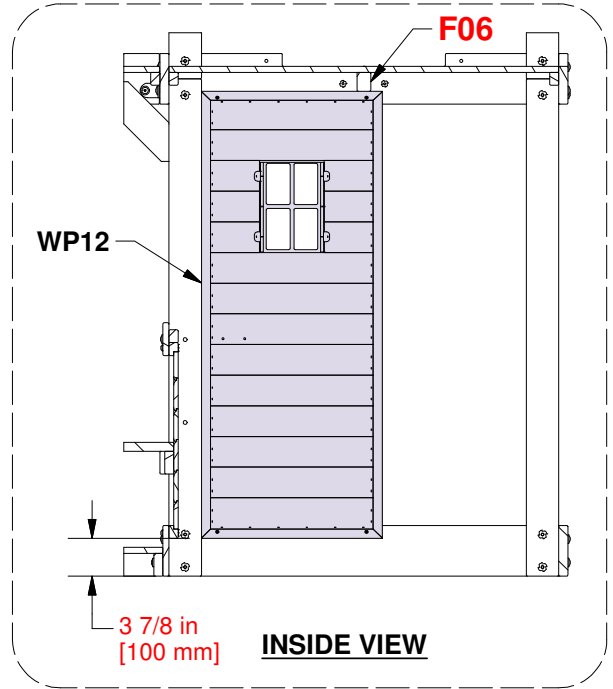
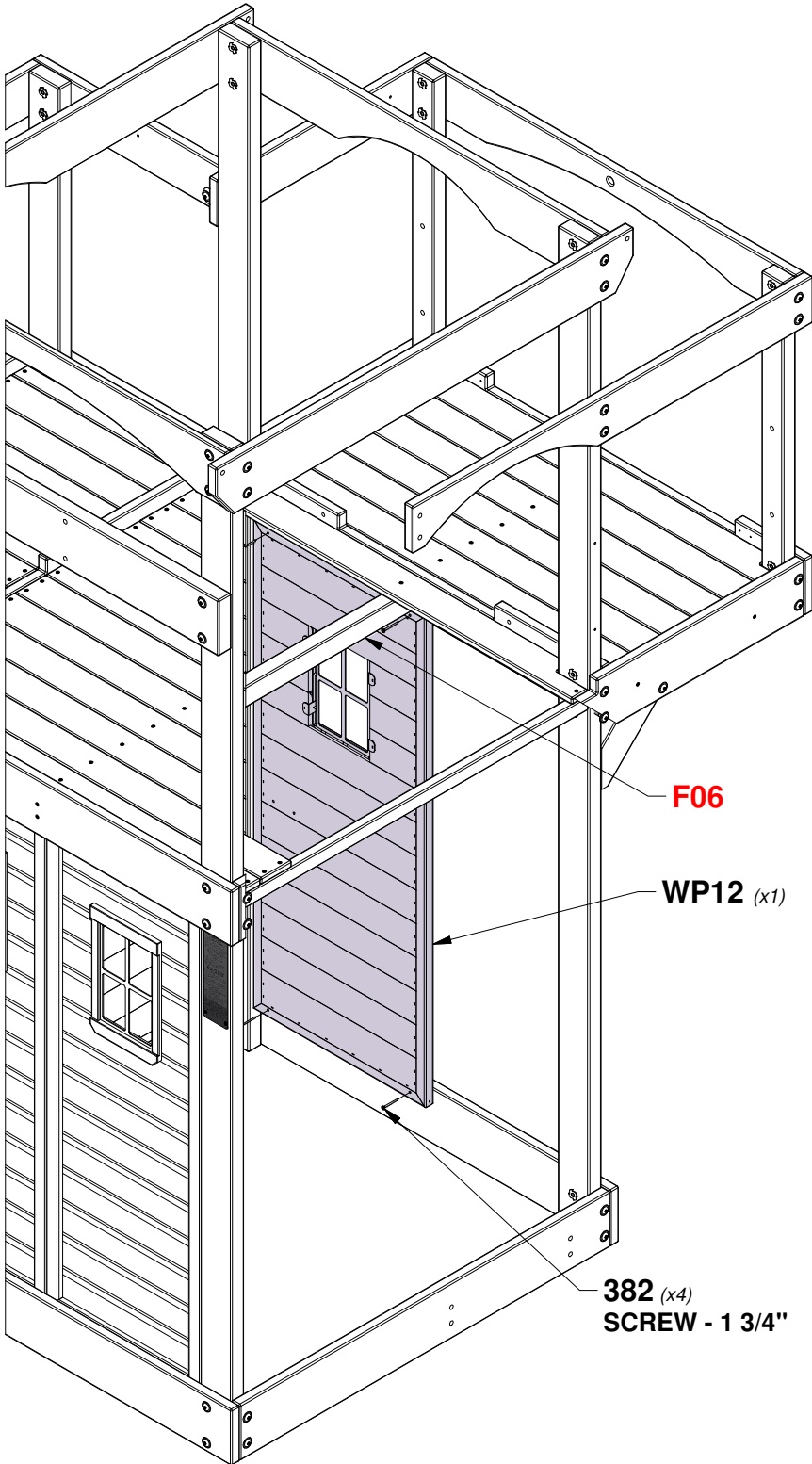

STEP 31 - FORT ASSEMBLY

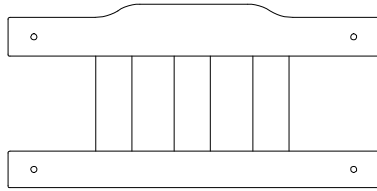

F04 SUPPORT BLOCK - W4L18517
 (x1) 1 3/8"x2 3/8"x9 1/4" (36x60x234)

WP10 BENCH BACK ASSEMBLY - W2A037777
 (x1) 1 1/8"x11 7/8"x24 1/4" (27x303x615)

QTY	PART NUMBER	DESCRIPTION
1	H100195	BOLT WH 5/16x2-3/4 BLK
4	H100198	WASHER LOCK EXT 8x19 BLK
3	H100200	SCREW PFH 8x1-1/2 BLK
4	H100379	T-NUT 5/16 BLK
3	H100457	BOLT WH 5/16x2 BLK

TIP:
INSTALL T-NUTS IN WOOD FIRST

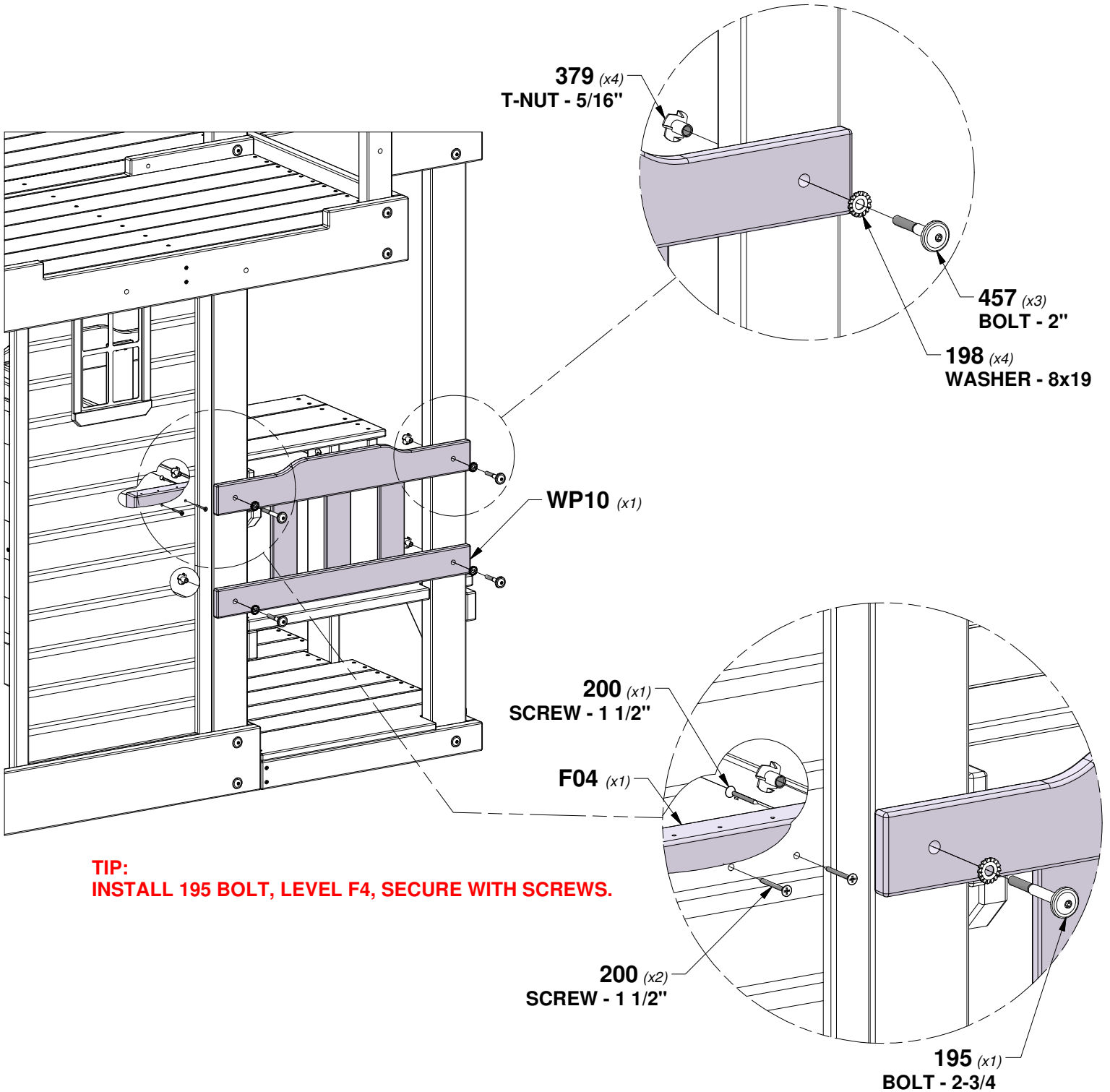

STEP 32 - FORT ASSEMBLY

QTY	PART NUMBER	DESCRIPTION
14	H100200	SCREW PFH 8x1-1/2 BLK



M06 COUNTER TOP - W4L18511
(x1) 5/8"x3 3/8"x37 5/8" (16x86x957)



M07 COUNTER TOP - W4L18512
(x2) 5/8"x3 3/8"x38 5/8" (16x86x981)

TIP:
ALIGN PILOT HOLES

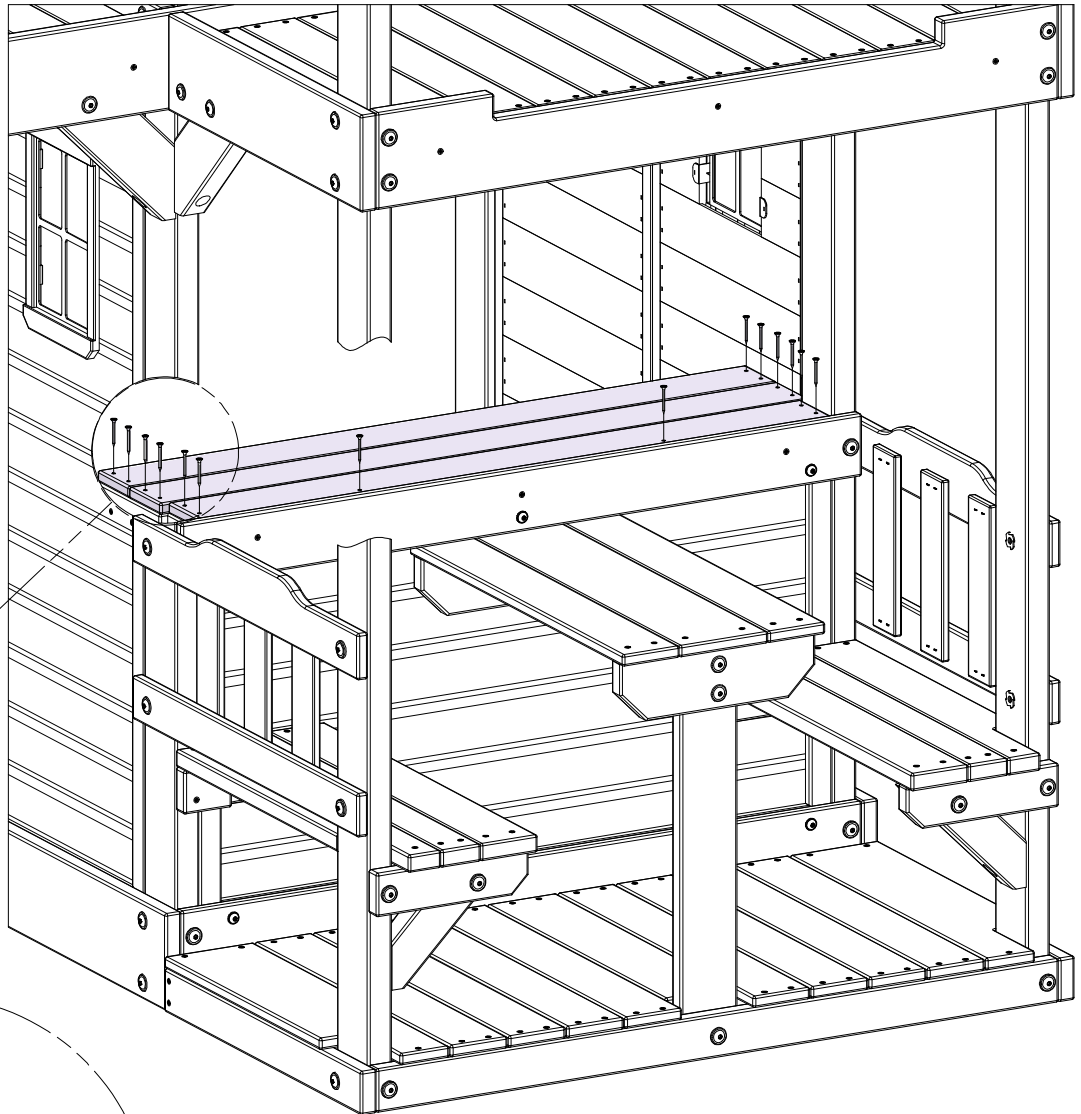

200 (x14)
SCREW - 1 1/2"

M07 (x2)

M06 (x1)

STEP 33 - FORT ASSEMBLY

QTY	PART NUMBER	DESCRIPTION
4	H100382	SCREW PFH 8x1 3/4 BLK

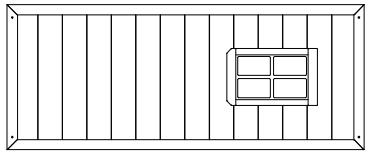

WP09 WALL PANEL - W2A03781
 (x1) 1"x16 7/8"x46 1/2" (24x479x1181)

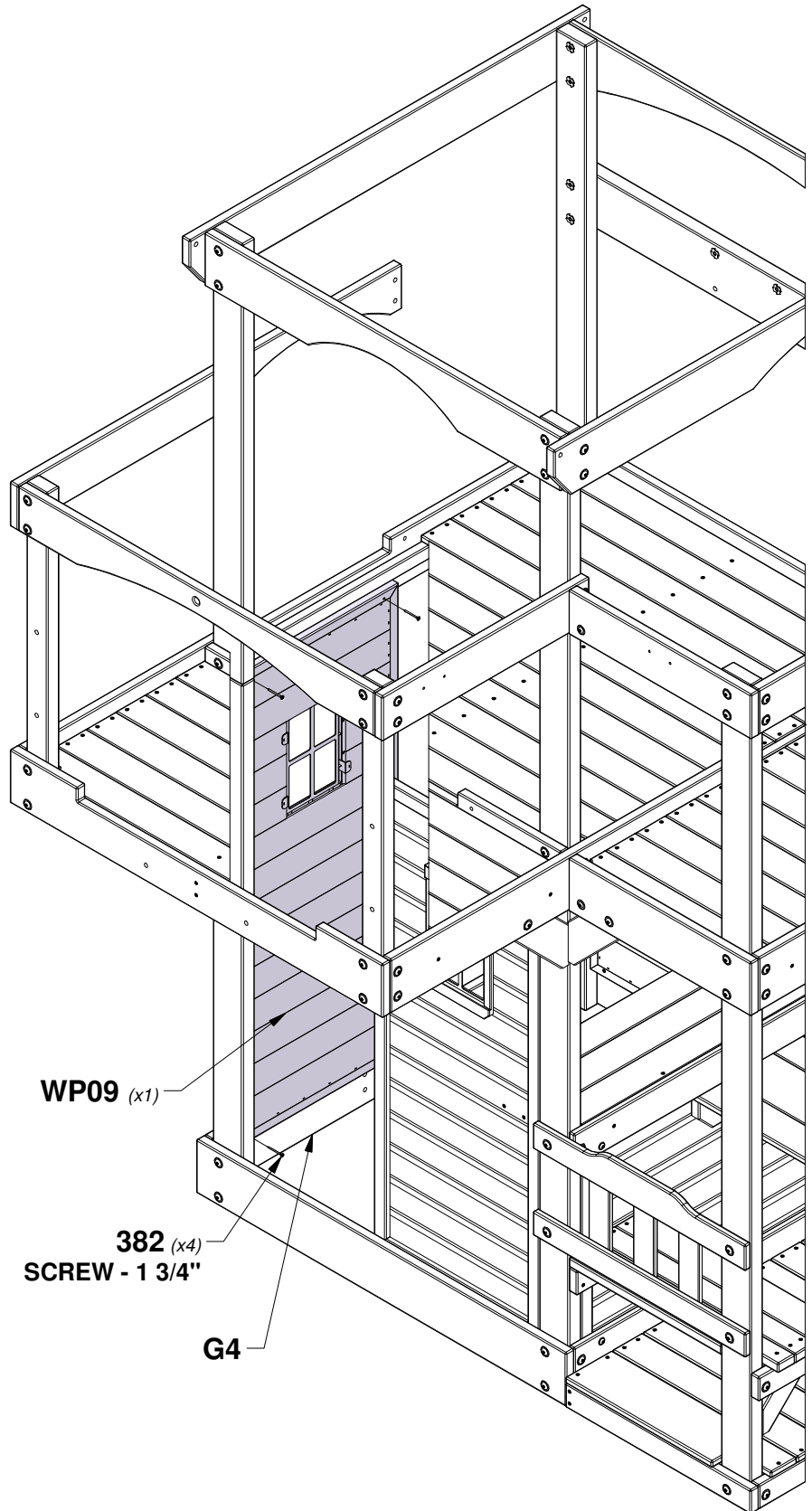
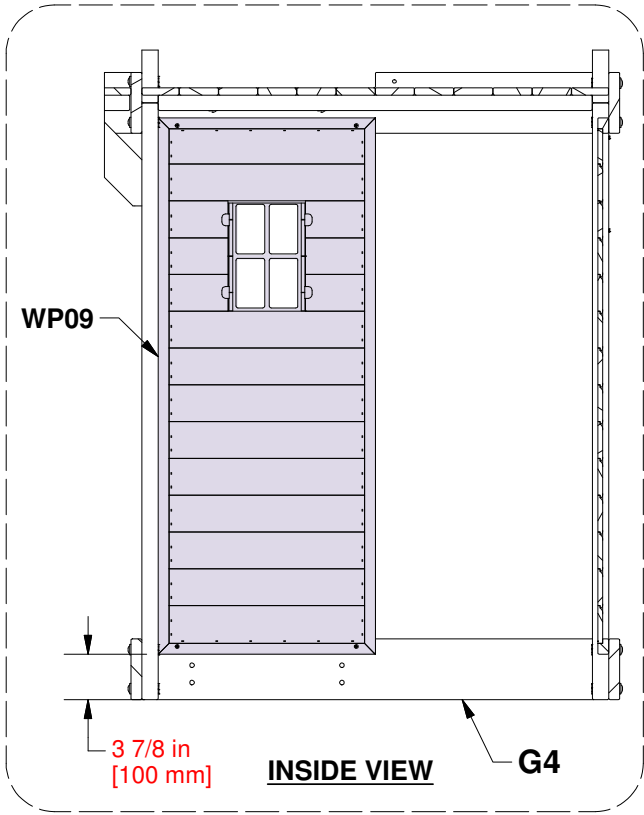

STEP 34 - FORT ASSEMBLY

QTY	PART NUMBER	DESCRIPTION
2	H100538	SCREW PFH 8x1 1/2 SD
2	H100544	SCREW PWH 8x5/8 SD

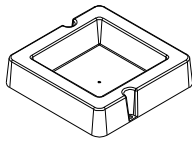
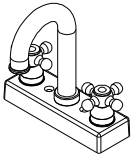

A6P00024
(x1) **FAUCET KIT**

A6P00032
(x1) **SURFACE MOUNT BASIN**

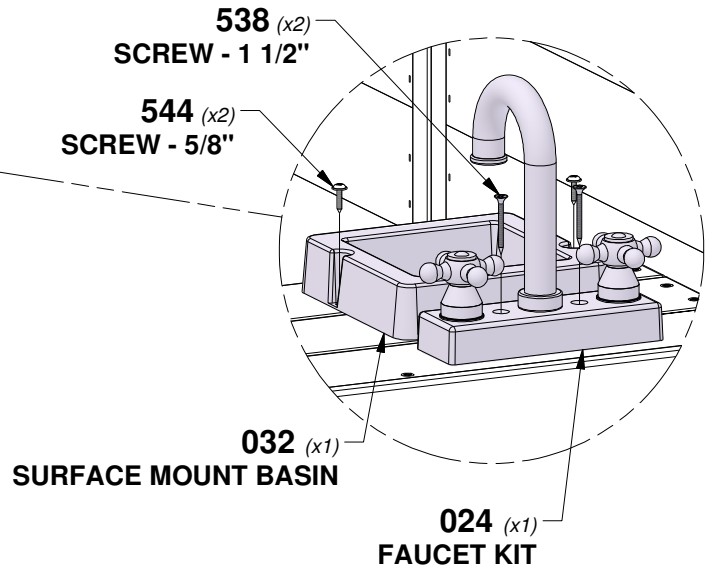
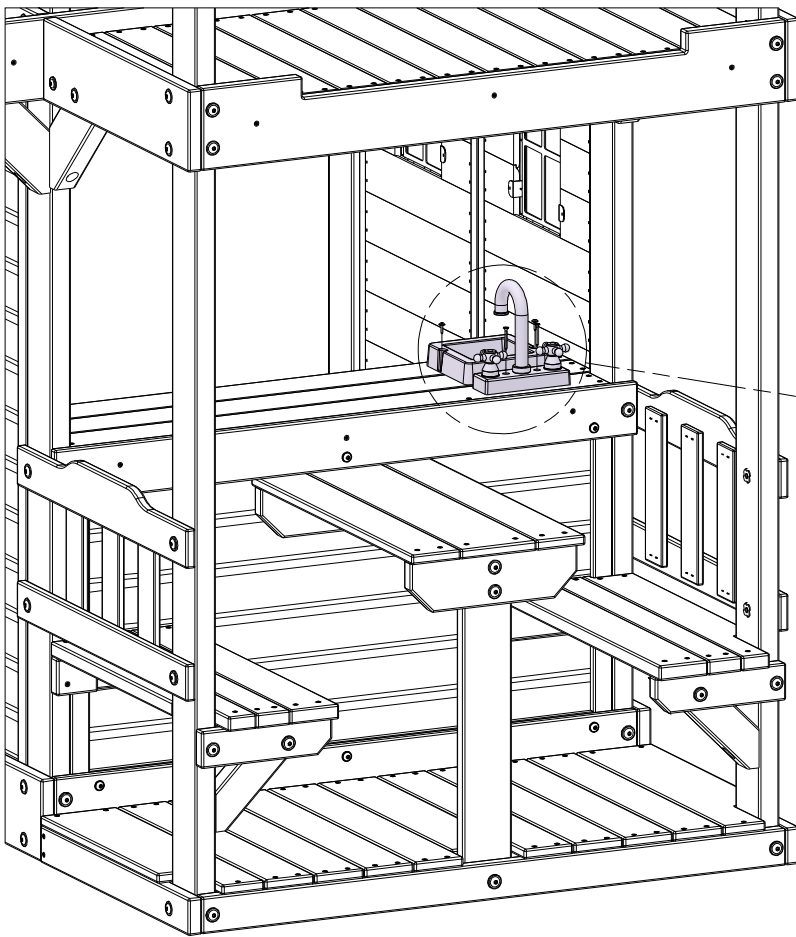
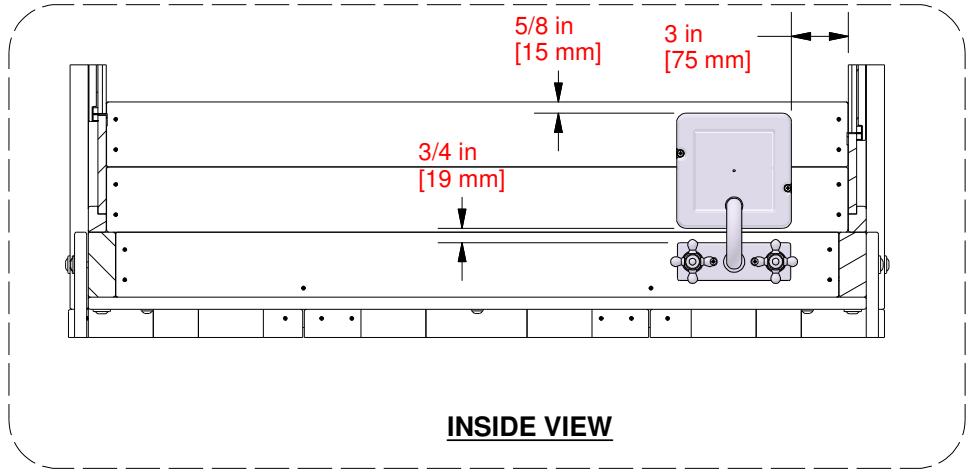

STEP 35 - FORT ASSEMBLY

QTY	PART NUMBER	DESCRIPTION
4	H100544	SCREW PWH 8x5/8 SD

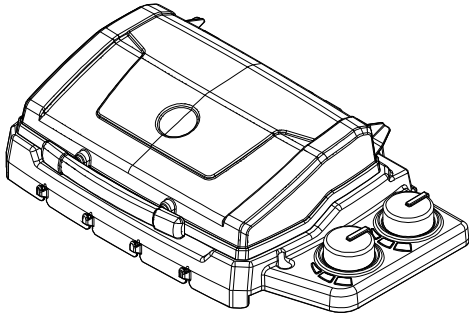

A6P00282 BBQ GRILL
(x1)

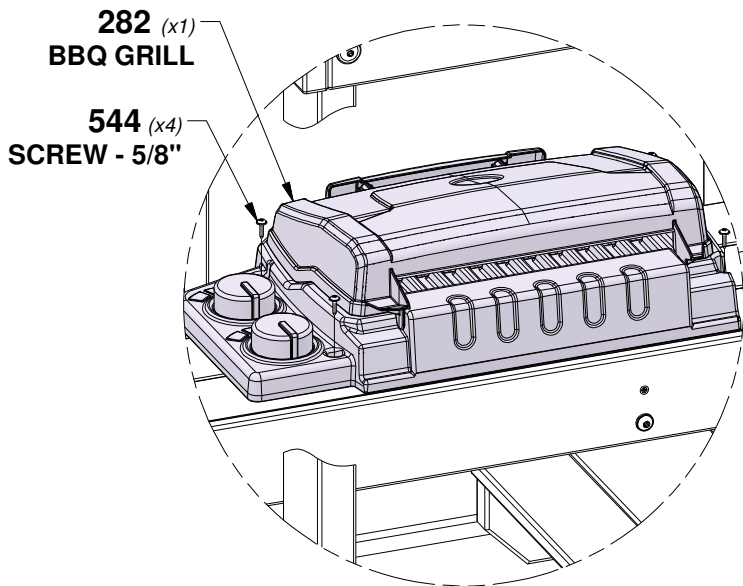
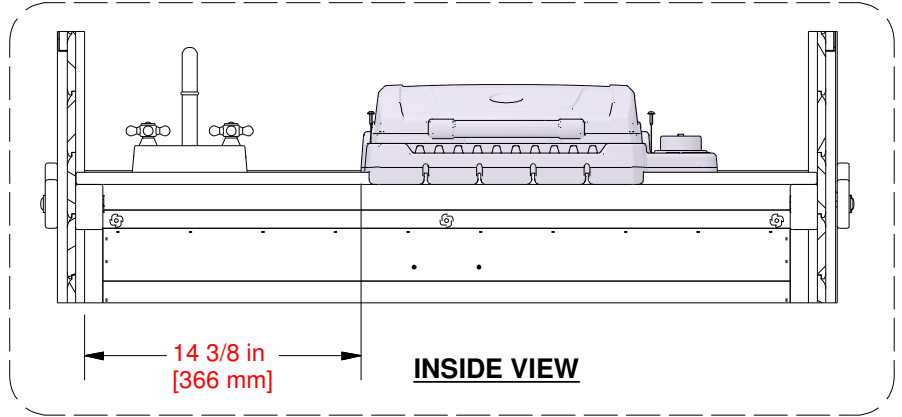

282 (x1)
BBQ GRILL

544 (x4)
SCREW - 5/8"

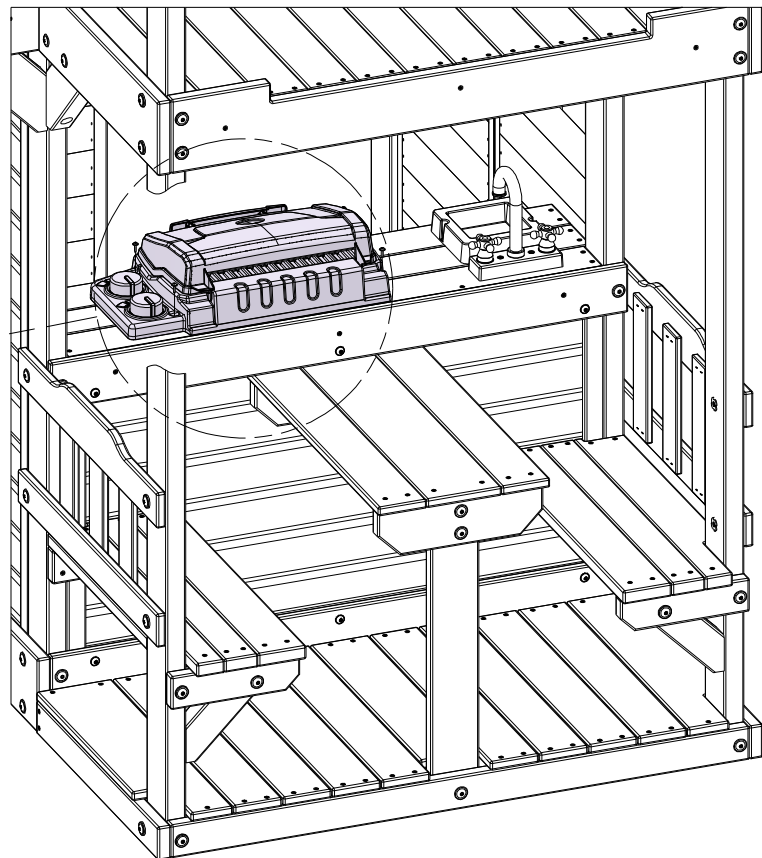

STEP 36 - FORT ASSEMBLY

QTY	PART NUMBER	DESCRIPTION
2	H100198	WASHER LOCK EXT 8x19 BLK
2	H100378	BOLT WH 5/16x1 3/4 BLK

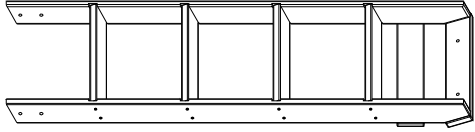

LADDER ASSEMBLY (x1)

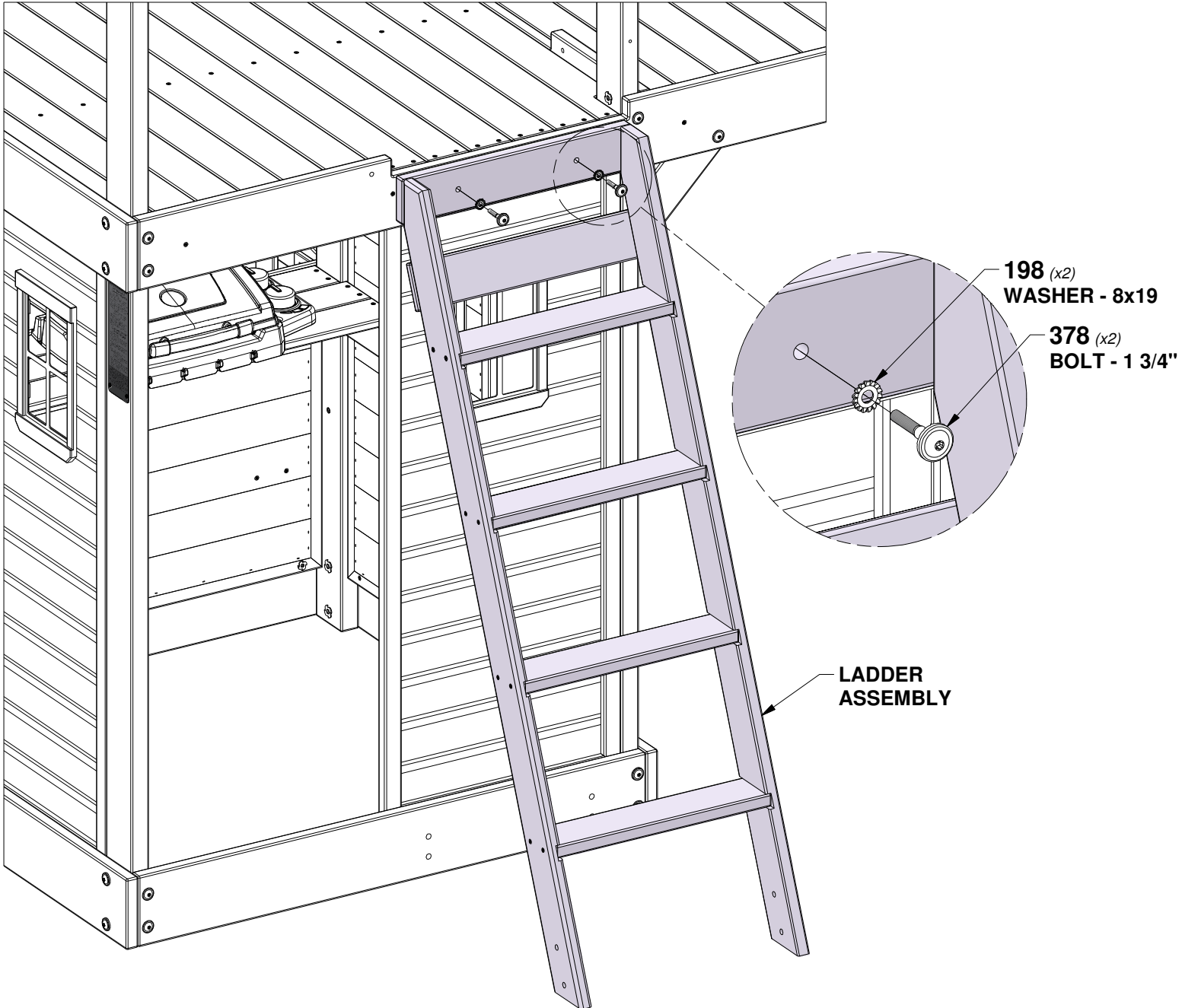

STEP 37 - FORT ASSEMBLY

QTY	PART NUMBER	DESCRIPTION
4	H100198	WASHER LOCK EXT 8x19 BLK
4	H100378	BOLT WH 5/16x1 3/4 BLK
12	H100379	T-NUT 5/16 BLK
8	H100468	BOLT WH 5/16x1 BLK

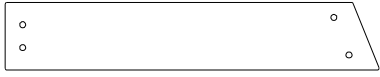

Q2 GROUND BOARD - W4L17640
(x2) 1"x4 3/8"x24 3/8" (24x112x620)

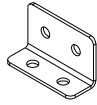

A4M00855 L BRACKET
(x2) 32x51x82

TIP:
INSTALL T-NUTS IN WOOD FIRST

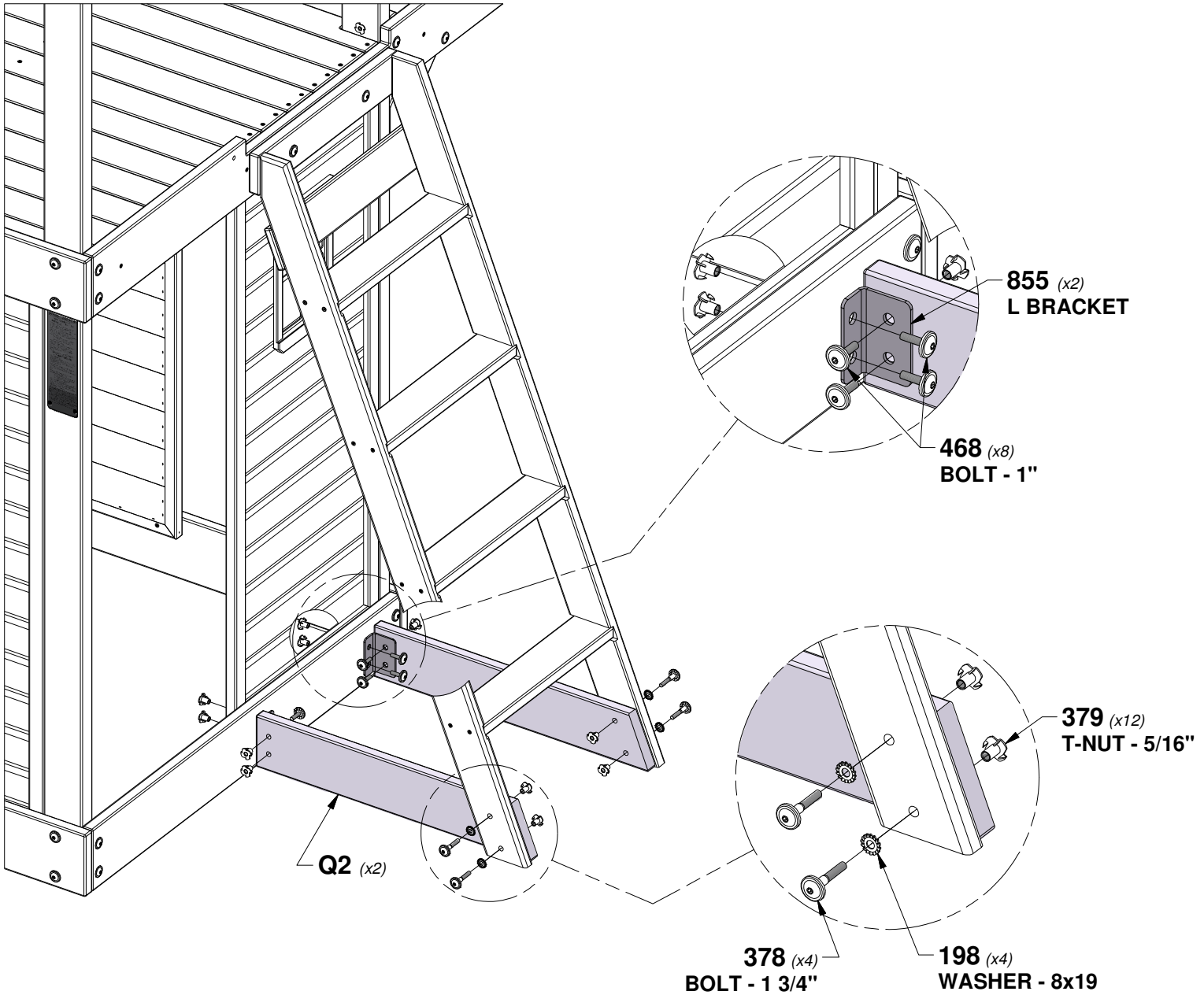

STEP 38 - FORT ASSEMBLY

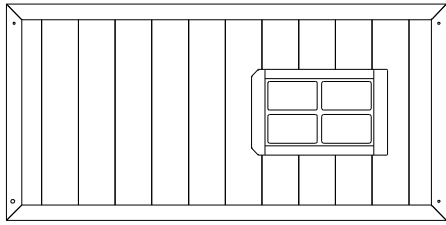

WP07 WALL PANEL - W2A03783
 (x1) 1"x16 7/8"x46 1/2" (24x476x971)

QTY	PART NUMBER	DESCRIPTION
3	H100382	SCREW PFH 8x1-3/4 BLK
1	H100398	T-NUT 1/4 BLK
1	H100405	WASHER LOCK EXT 6x15 BLK
1	H101026	BOLT WH 1/4x1-3/4 BLK

TIP:
INSTALL T-NUTS IN WOOD FIRST

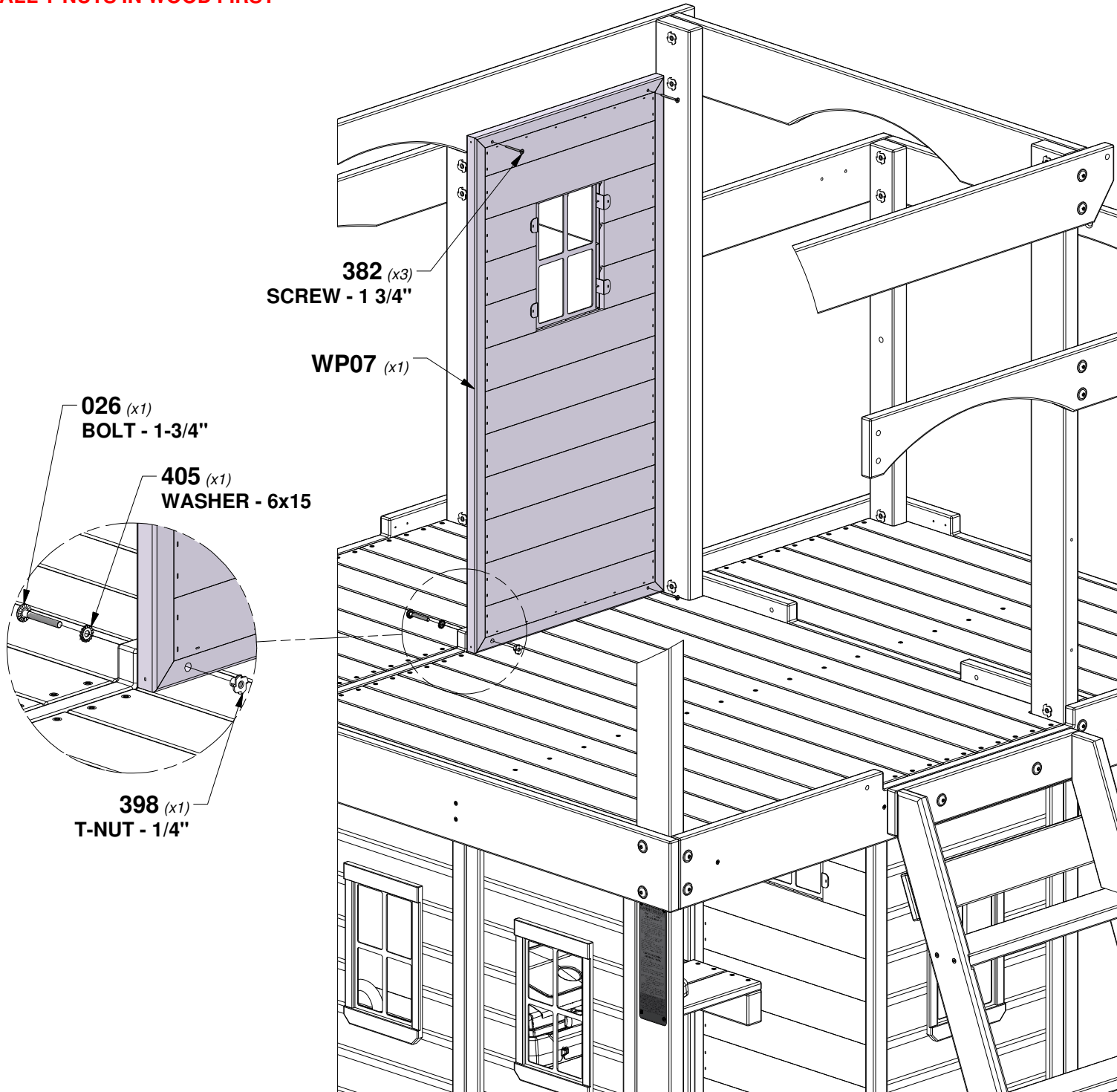

STEP 39 - FORT ASSEMBLY

QTY	PART NUMBER	DESCRIPTION
4	H100382	SCREW PFH 8x1 3/4 BLK
4	H100391	SCREW PFH 8x2 BLK

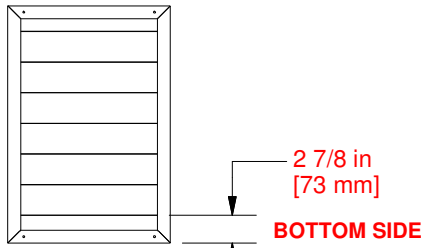

WP04 WALL PANEL - W2A03784
 (x2) 1"x16 7/8"x24 5/8" (24x430x627)

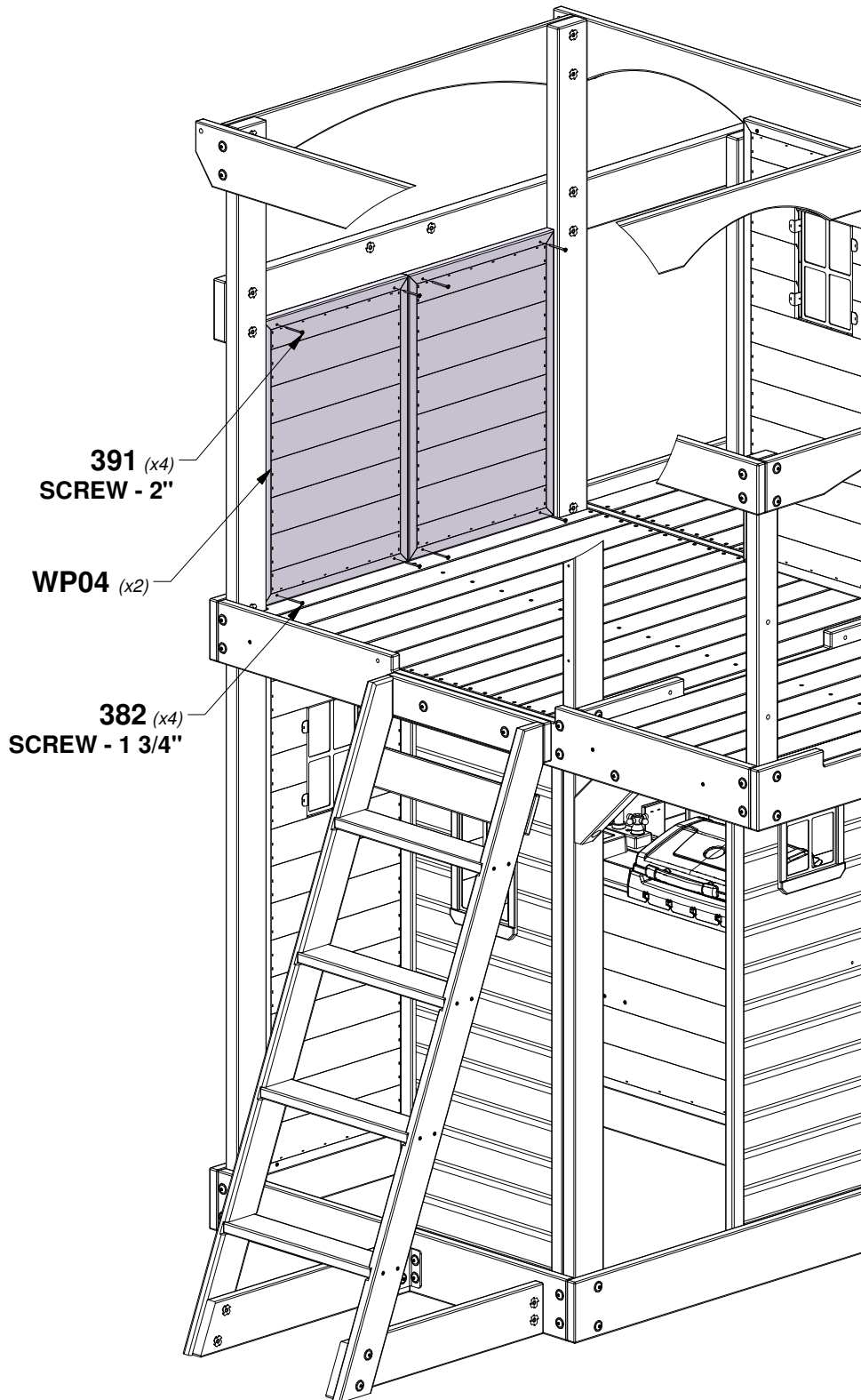
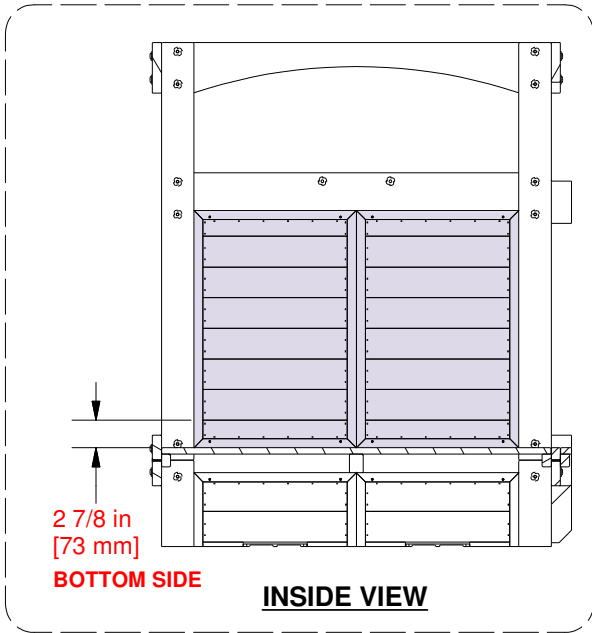

STEP 40 - FORT ASSEMBLY

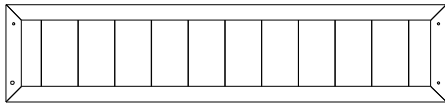

WP03 WALL PANEL - W2A03786
(x1) 1"x18 7/8"x11 3/4" (24x214x971)

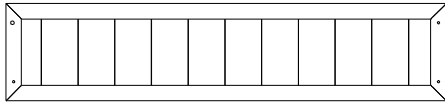

WP08 WALL PANEL - W2A03787
(x1) 1"x18 7/8"x11 3/4" (24x214x971)

QTY	PART NUMBER	DESCRIPTION
6	H100382	SCREW PFH 8x1-3/4 BLK
2	H100398	T-NUT 1/4 BLK
2	H100405	WASHER LOCK EXT 6x15 BLK
2	H101026	BOLT WH 1/4x1-3/4 BLK

TIP:
INSTALL T-NUTS IN WOOD FIRST

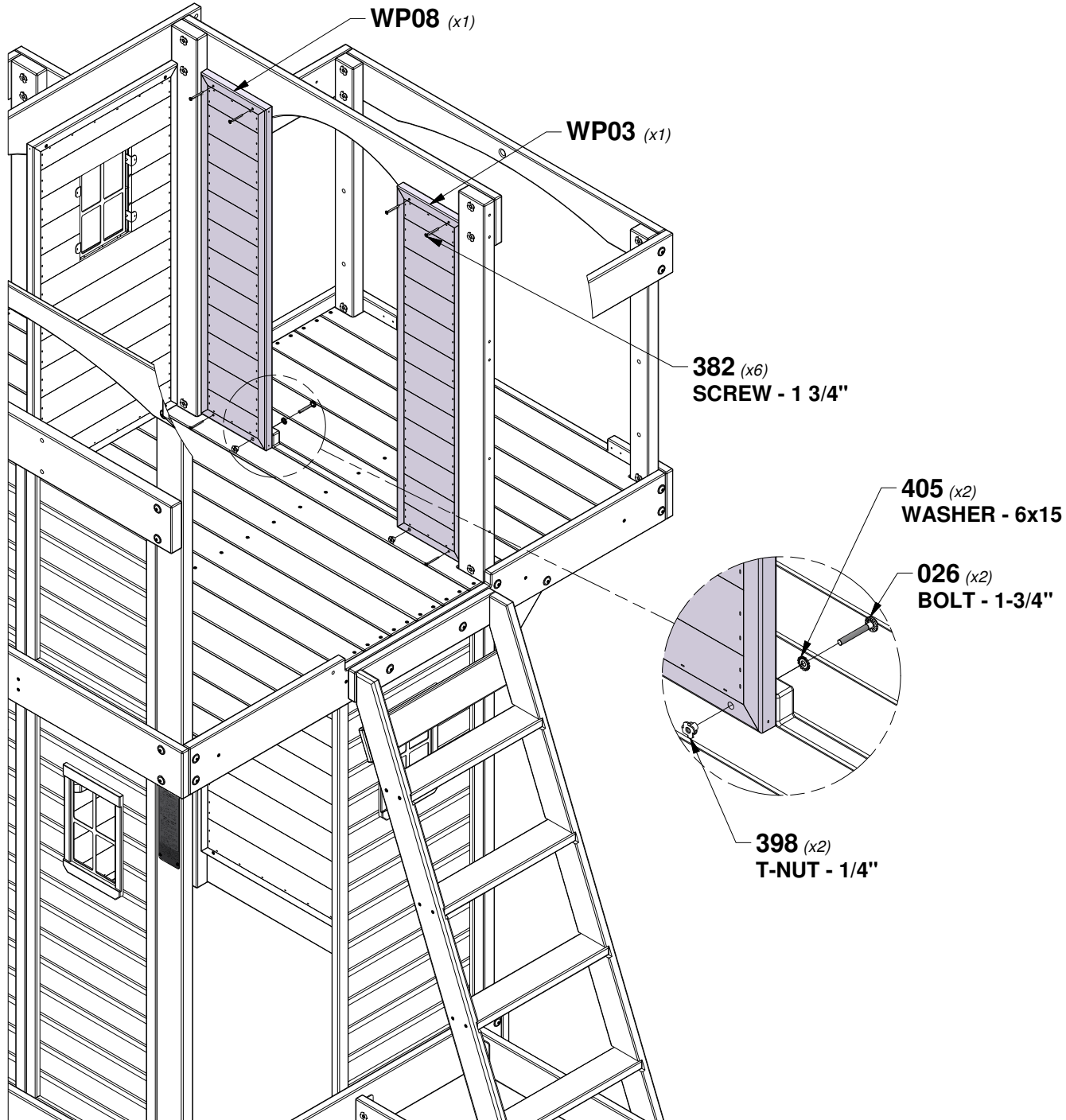

STEP 41 - FORT ASSEMBLY

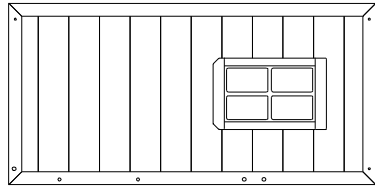

WP05 WALL PANEL - W2A03785
(x1) 1"x16 7/8"x46 1/2" (24x479x971)

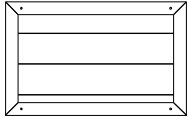

WP06 WALL PANEL - W2A03780
(x1) 1"x18 7/8"x11 3/4" (24x479x300)

QTY	PART NUMBER	DESCRIPTION
2	H100198	WASHER LOCK EXT 8x19 BLK
2	H100378	BOLT WH 5/16x1 3/4 BLK
2	H100379	T-NUT 5/16 BLK
7	H100382	SCREW PFH 8x1-3/4 BLK
1	H100398	T-NUT 1/4 BLK
1	H100405	WASHER LOCK EXT 6x15 BLK
1	H101026	BOLT WH 1/4x1-3/4 BLK

TIP:
INSTALL T-NUTS IN WOOD FIRST

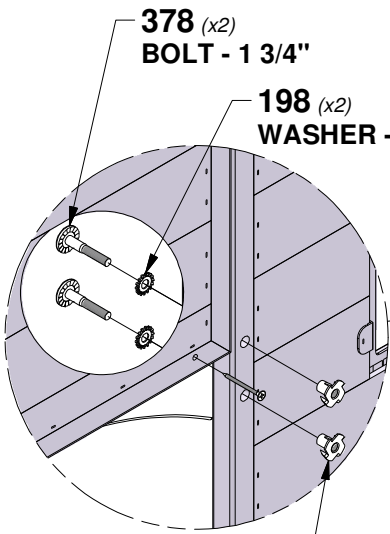

378 (x2)
BOLT - 1 3/4"

198 (x2)
WASHER - 8x19

379 (x2)
T-NUT - 5/16"

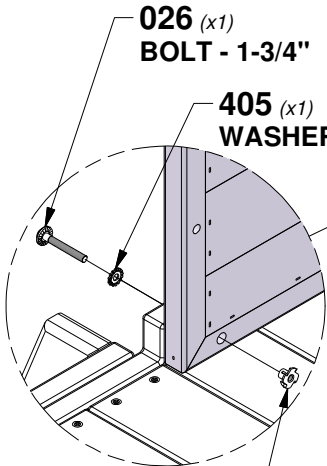

026 (x1)
BOLT - 1-3/4"

405 (x1)
WASHER - 6x15

398 (x1)
T-NUT - 1/4"

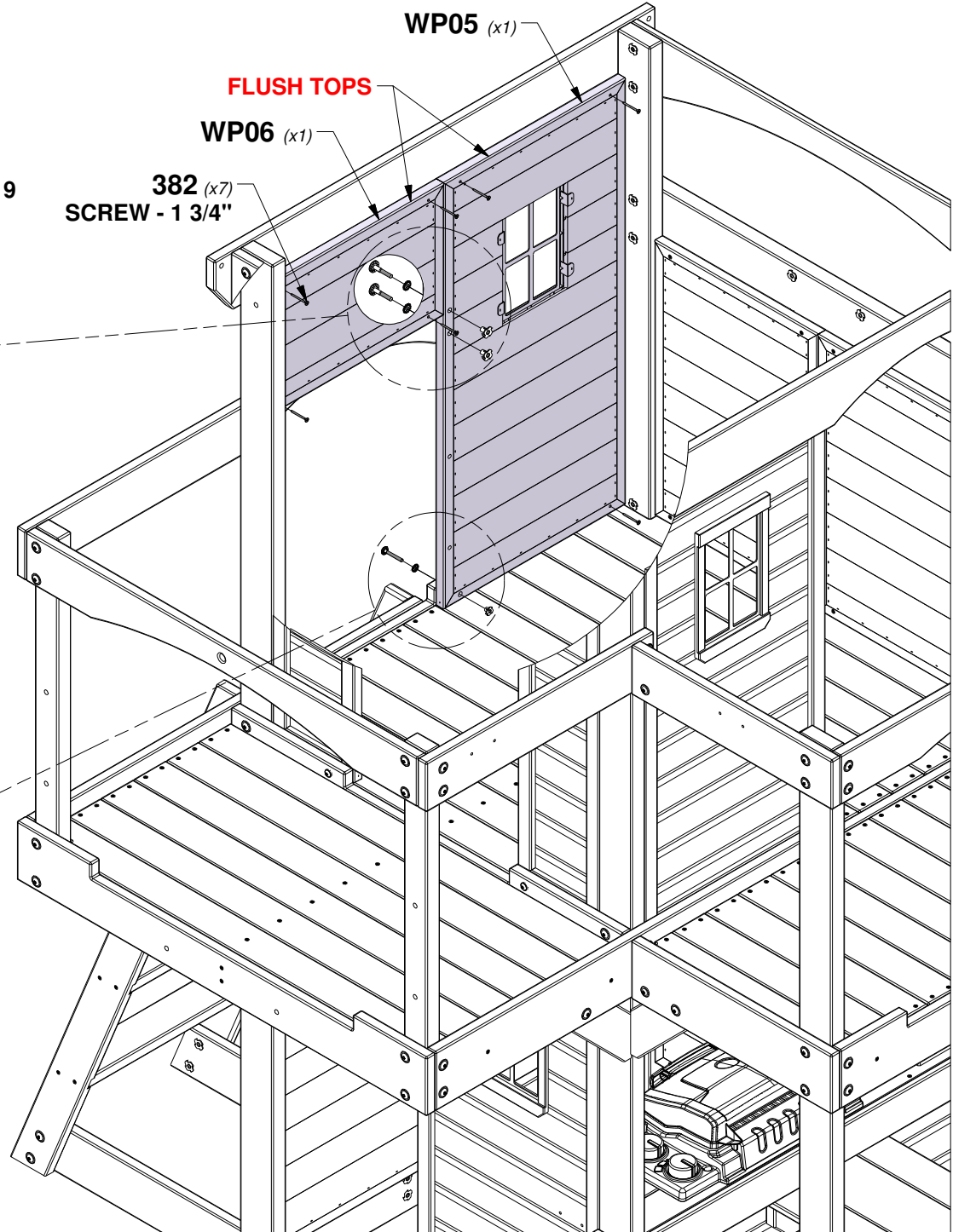

STEP 42 - FORT ASSEMBLY

QTY	PART NUMBER	DESCRIPTION
32	H100387	SCREW PFH 8x1-1/4 BLK

N02 PICKET - W4L18514
(x8) 5/8"x2 3/8"x24 3/4" (16x60x628)

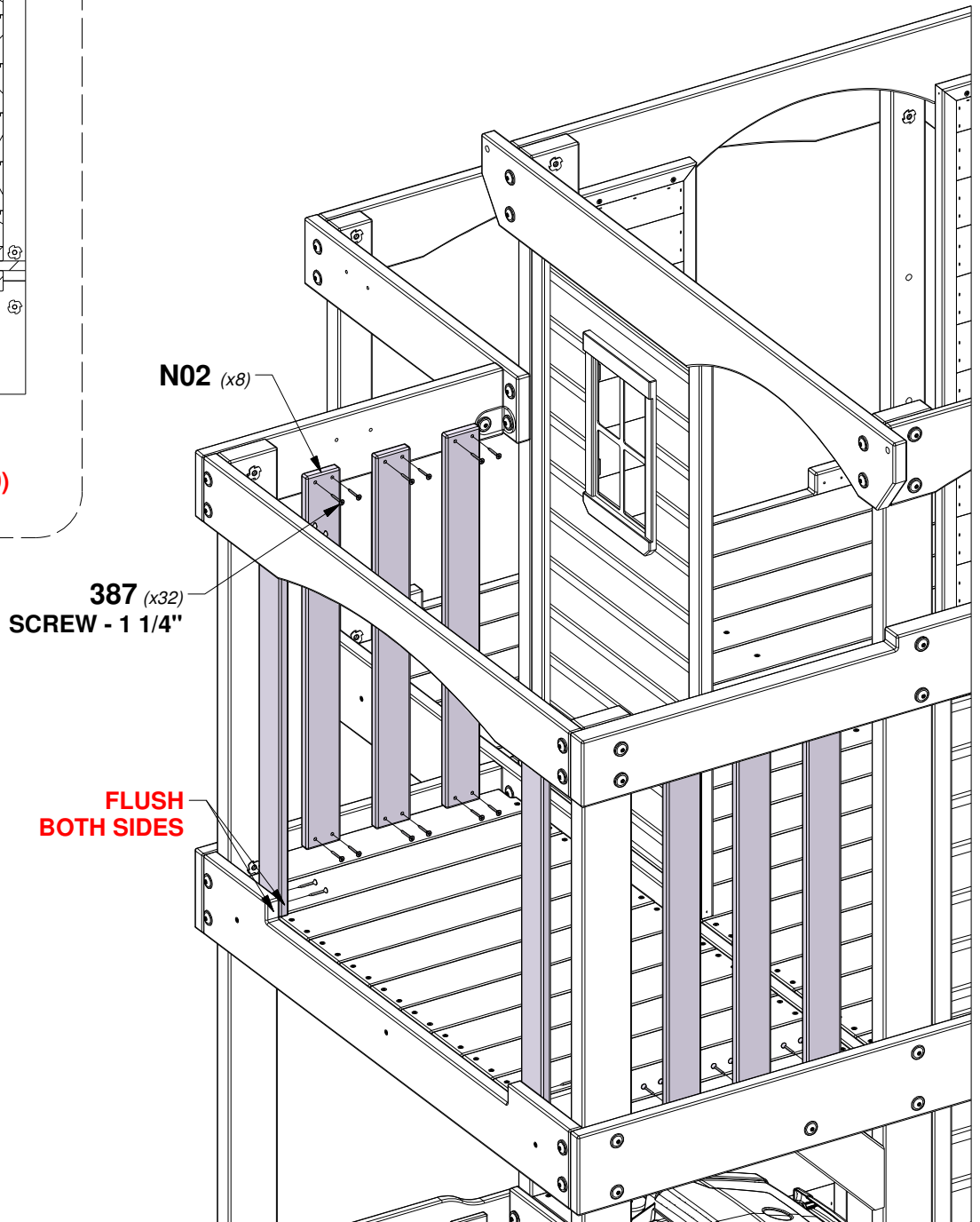
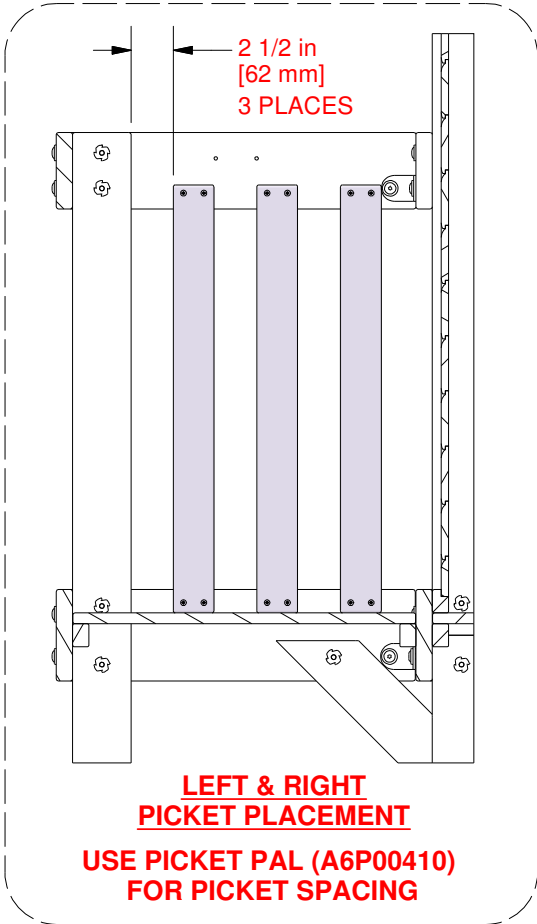

STEP 43 - FORT ASSEMBLY

QTY	PART NUMBER	DESCRIPTION
40	H100387	SCREW PFH 8x1-1/4 BLK



N02 PICKET - W4L18514
 (x10) 5/8"x2 3/8"x24 3/4" (16x60x628)

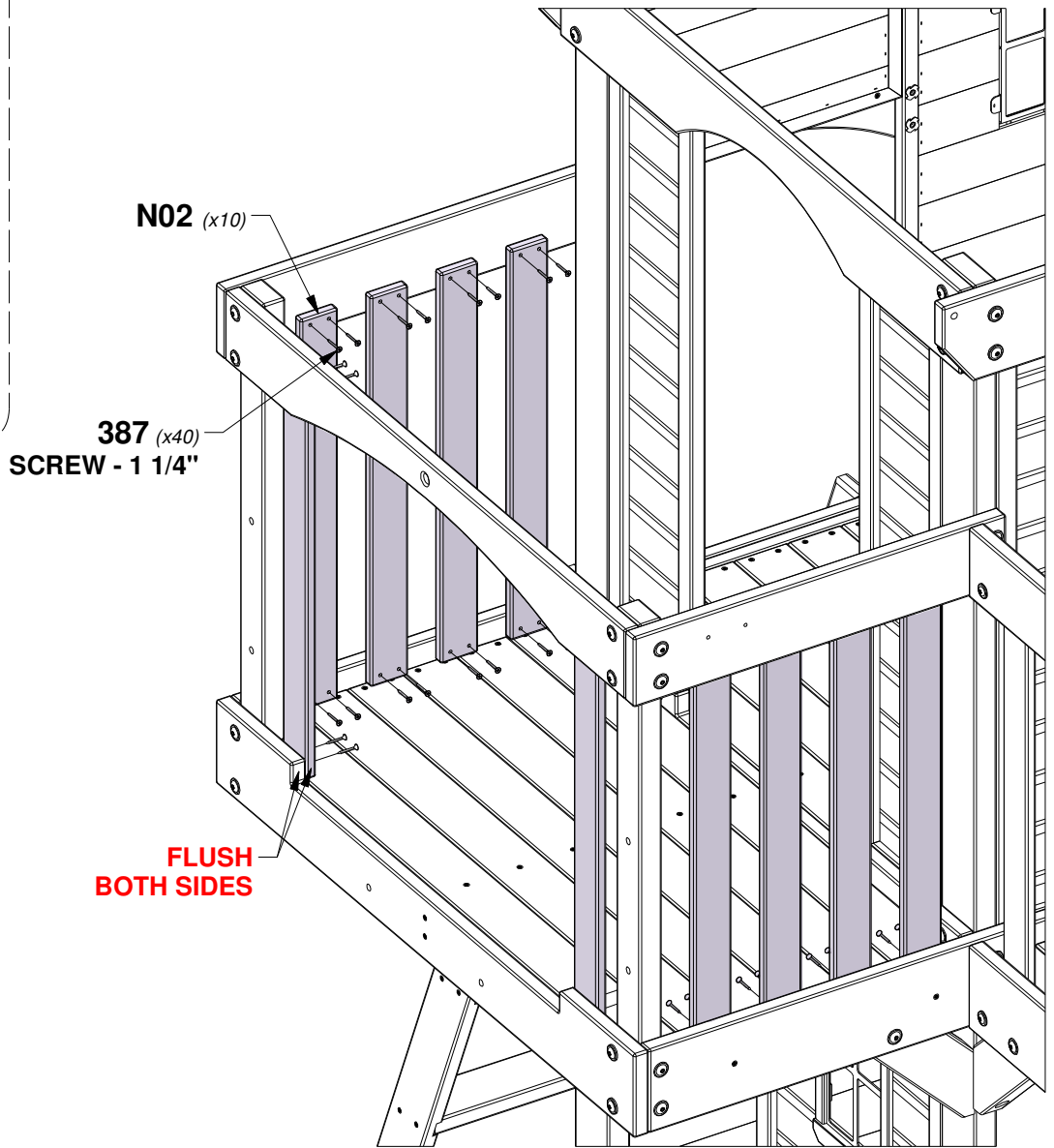
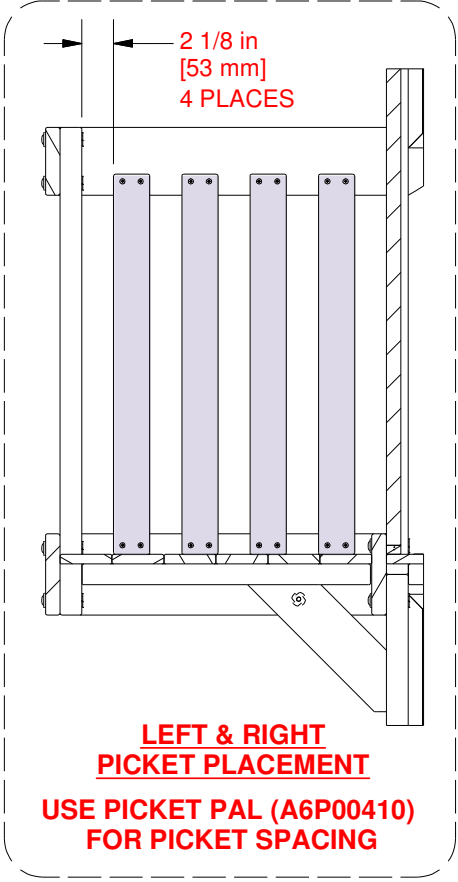

STEP 44 - FORT ASSEMBLY

QTY	PART NUMBER	DESCRIPTION
2	H100198	WASHER LOCK EXT 8x19 BLK
2	H100379	T-NUT 5/16 BLK
2	H100407	BOLT WH 5/16x1 1/2 BLK
6	H100408	SCREW PWH 8x1/2 BLK

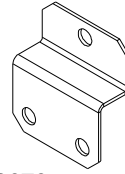
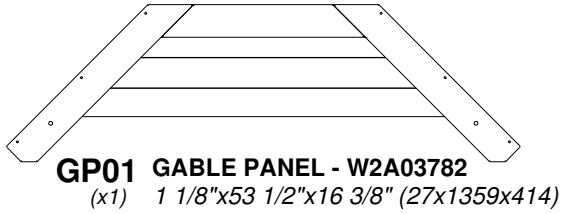
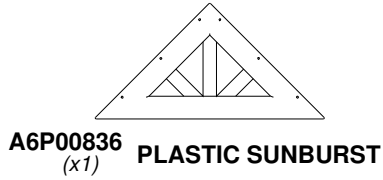

TIP:
INSTALL T-NUTS IN WOOD FIRST

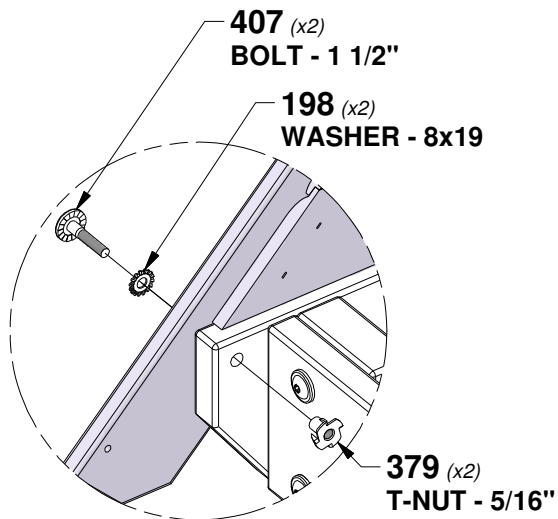

**INSTALL BRACKET TO SUNBURST
THEN PRE-DRILL USING AN
1/8" [3mm] DRILL BIT**

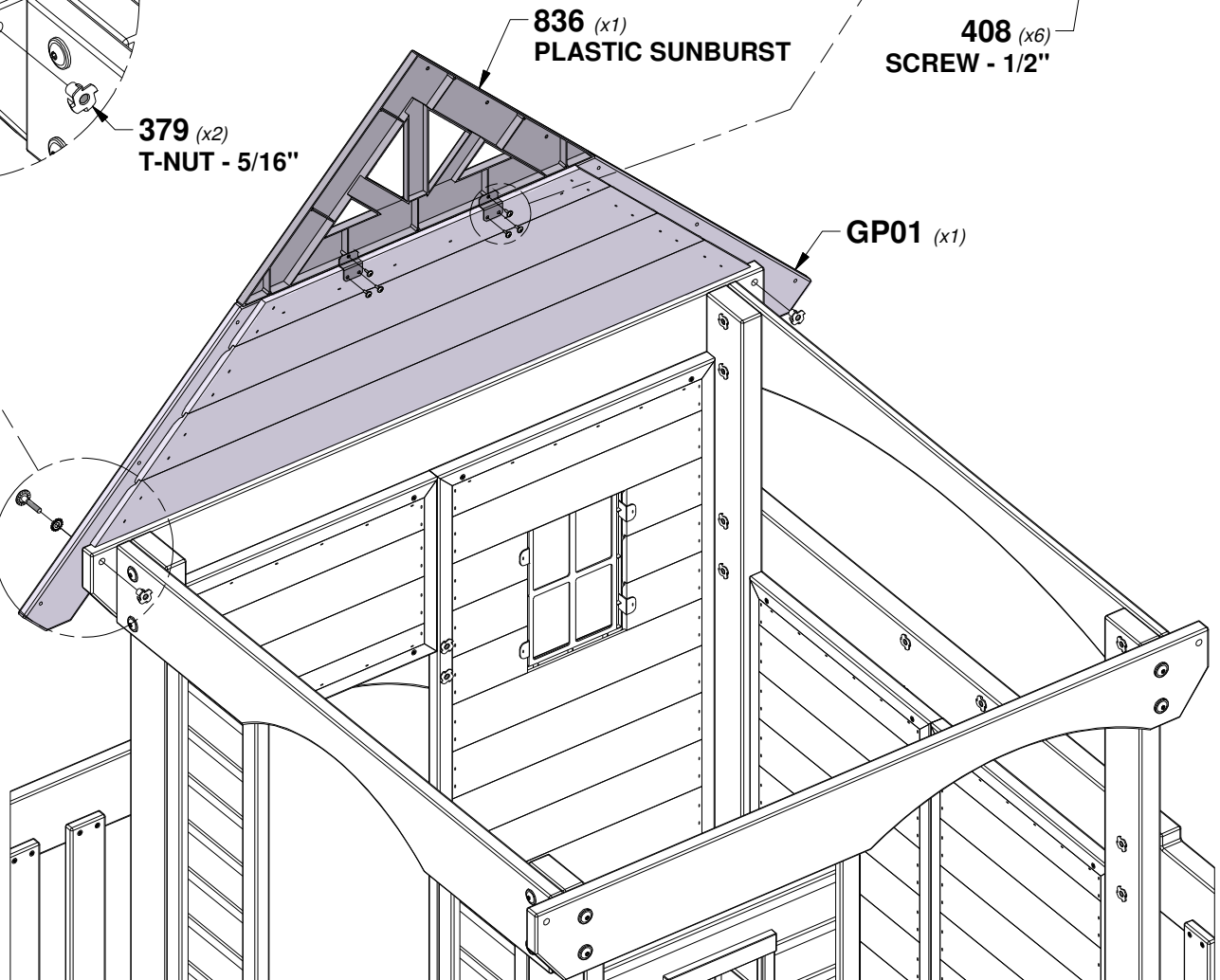
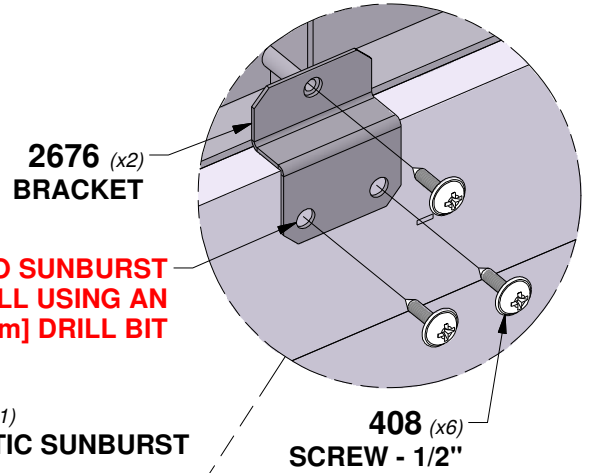

STEP 45 - FORT ASSEMBLY

QTY	PART NUMBER	DESCRIPTION
2	H100198	WASHER LOCK EXT 8x19 BLK
2	H100379	T-NUT 5/16 BLK
2	H100407	BOLT WH 5/16x1 1/2 BLK
6	H100408	SCREW PWH 8x1/2 BLK

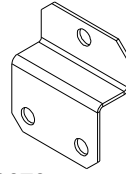
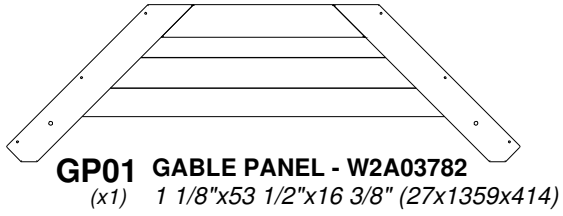
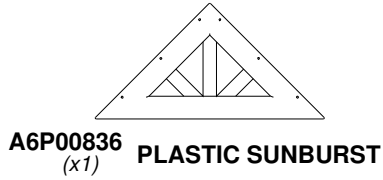

TIP:
INSTALL T-NUTS IN WOOD FIRST

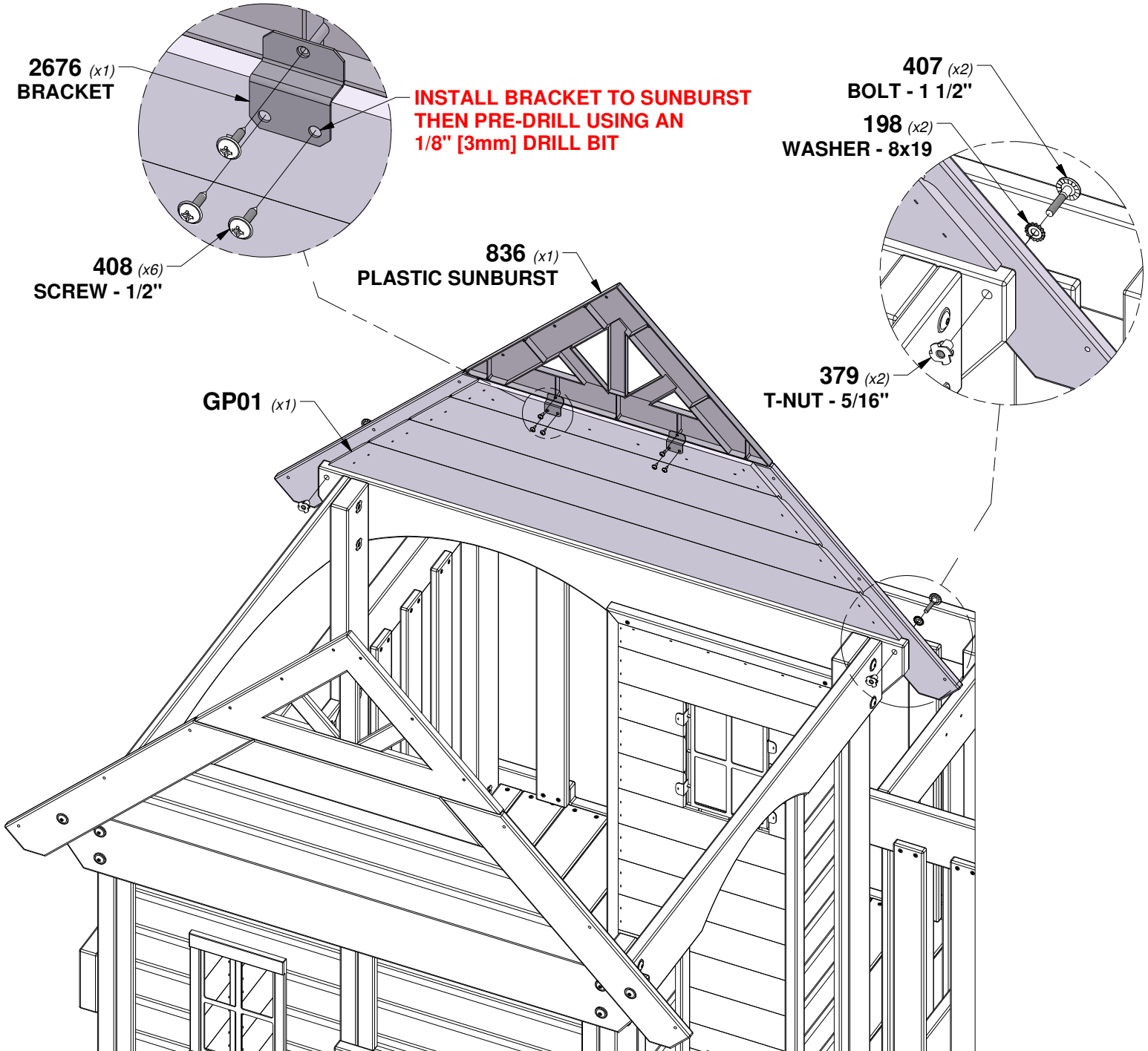

STEP 46 - FORT ASSEMBLY

QTY	PART NUMBER	DESCRIPTION
12	H100347	SCREW PWH 8x1-1/4 WZ
4	H100382	SCREW PFH 8x1 3/4 BLK

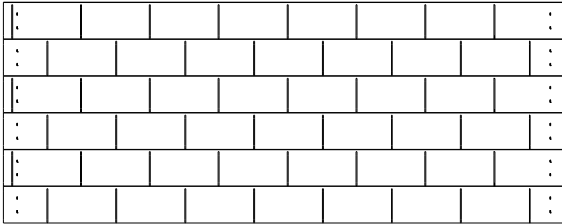

RP2 TOP ROOF PANEL - W2A04025
 (x2) 1 3/8"x19 1/8"x48 5/8" (35x486x1236)

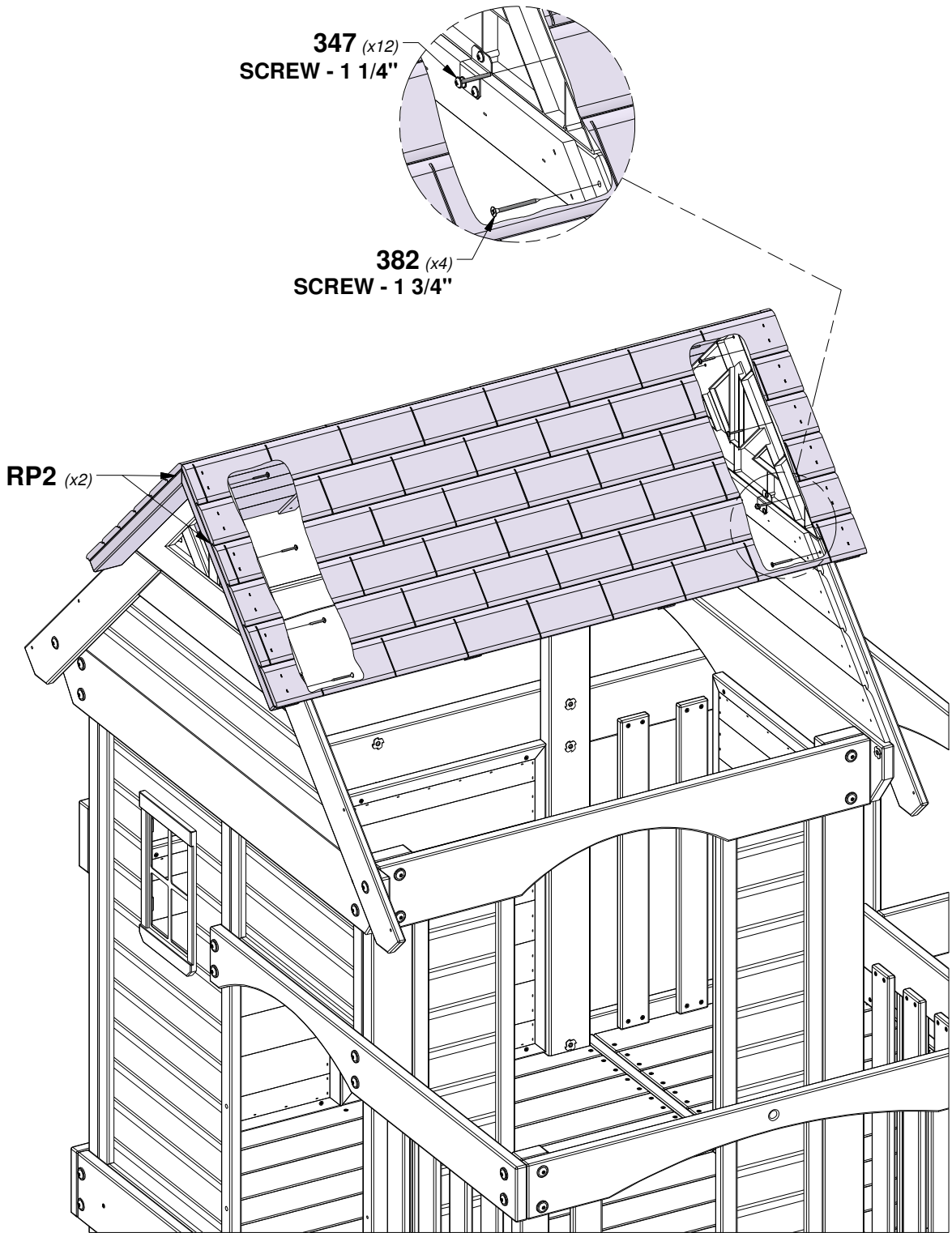

STEP 47 - FORT ASSEMBLY

QTY	PART NUMBER	DESCRIPTION
8	H100382	SCREW PFH 8x1 3/4 BLK

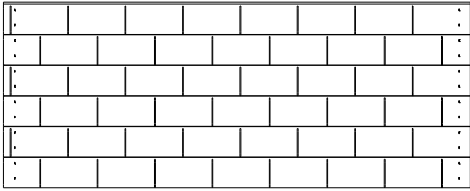

RP1 LOWER ROOF PANEL - W2A04024
(x2) 1 3/8"x19 3/8"x48 5/8" (35x491x1236)

382 (x8)
SCREW - 1 3/4"

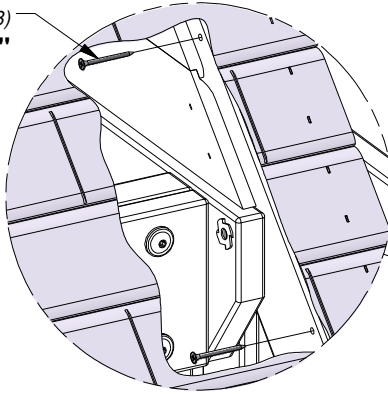

RP1 (x2)

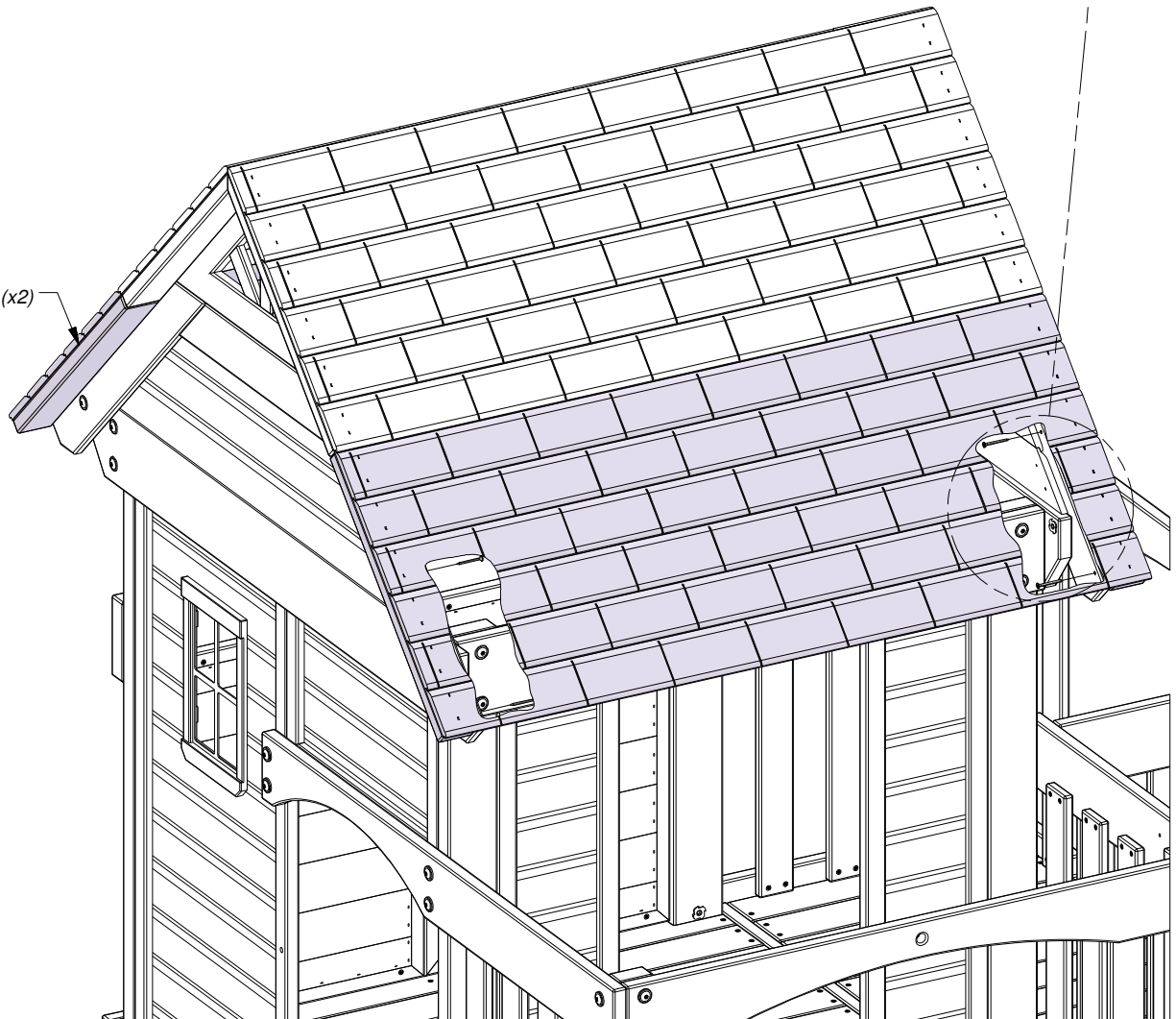

STEP 48 - FORT ASSEMBLY

QTY	PART NUMBER	DESCRIPTION
2	H100382	SCREW PFH 8x1 3/4 BLK
3	H100105	WASHER FLAT 8x27

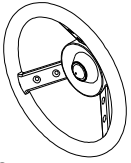

A6P00618
(x1) **STEERING WHEEL**

E12 MOUNTING BLOCK - W4L17816
(x1) 1 3/8"x3"x4 3/4" (36x76x120)

TIP:
ALIGN PILOT HOLES

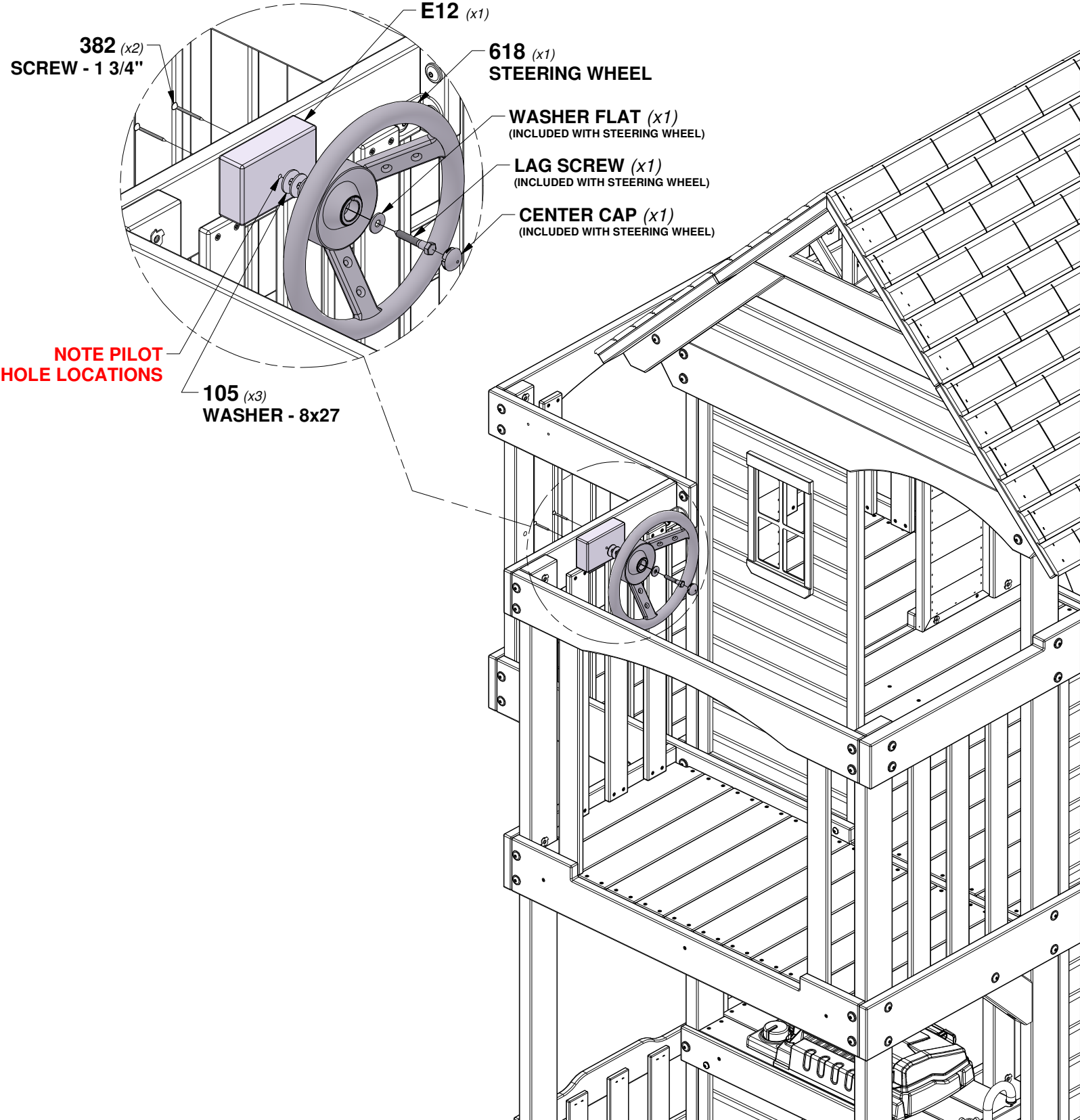

STEP 49 - FORT ASSEMBLY

QTY	PART NUMBER	DESCRIPTION
2	H100382	SCREW PFH 8x1 3/4 BLK
2	H100387	SCREW PFH 8x1-1/4 BLK

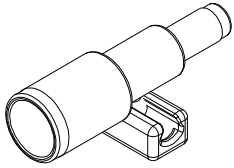

A6P00596
(x1) **TELESCOPE**



E10 MOUNTING BLOCK - W4L17815
(x1) 1 3/8"x3"x4 3/4" (36x76x120)

TIP:
ALIGN PILOT HOLES

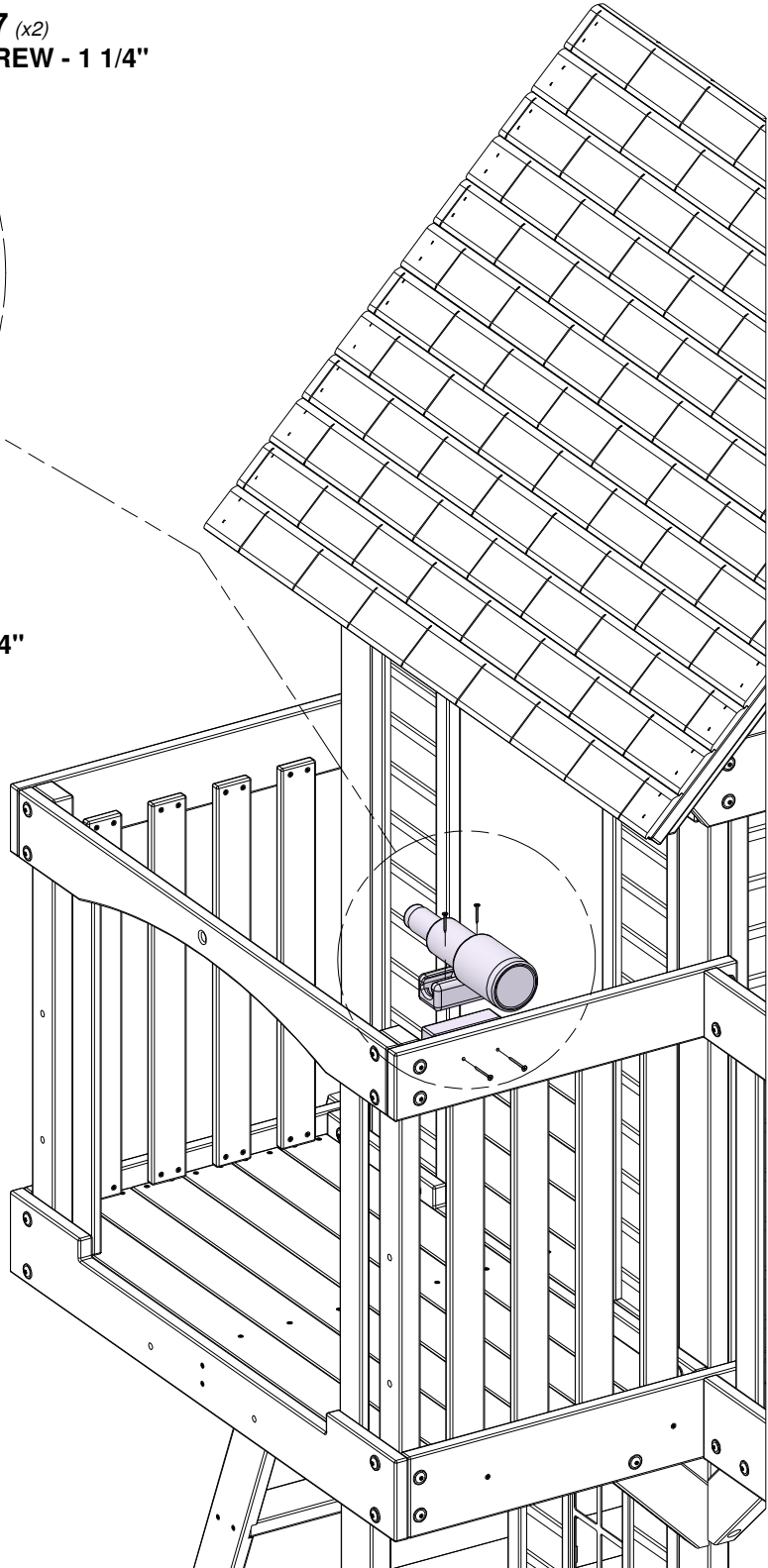
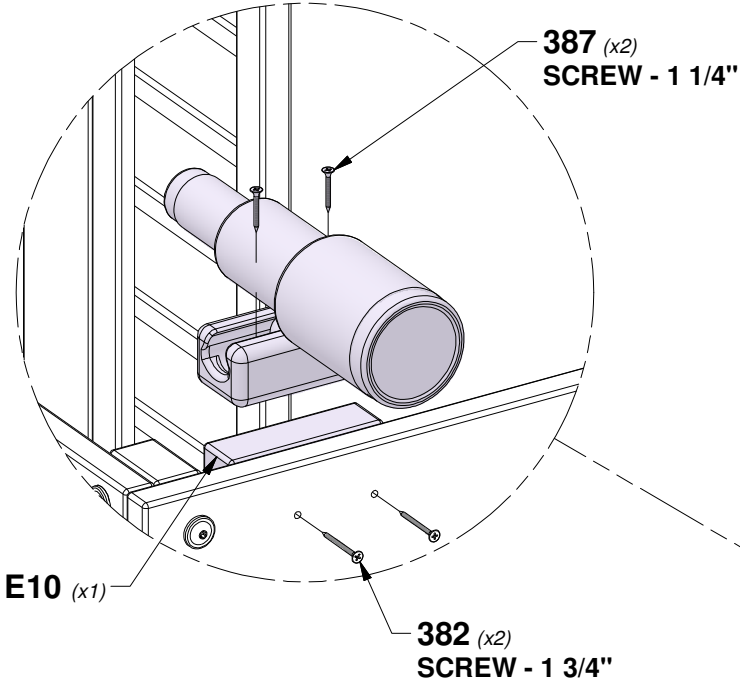

STEP 50 - FORT ASSEMBLY

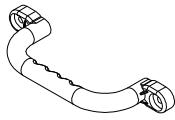

A6P00654 HAND GRIP
(x4) **GREY PLASTIC**

QTY	PART NUMBER	DESCRIPTION
2	H100397	BOLT WH 1/4x1-1/4 BLK
6	H100398	T-NUT 1/4 BLK
2	H100403	LAG SCREW WH 1/4x1-1/2 BLK
8	H100405	WASHER LOCK EXT 6x15 BLK
4	H101026	BOLT WH 1/4x1-3/4 BLK

TIP:
INSTALL T-NUTS IN WOOD FIRST

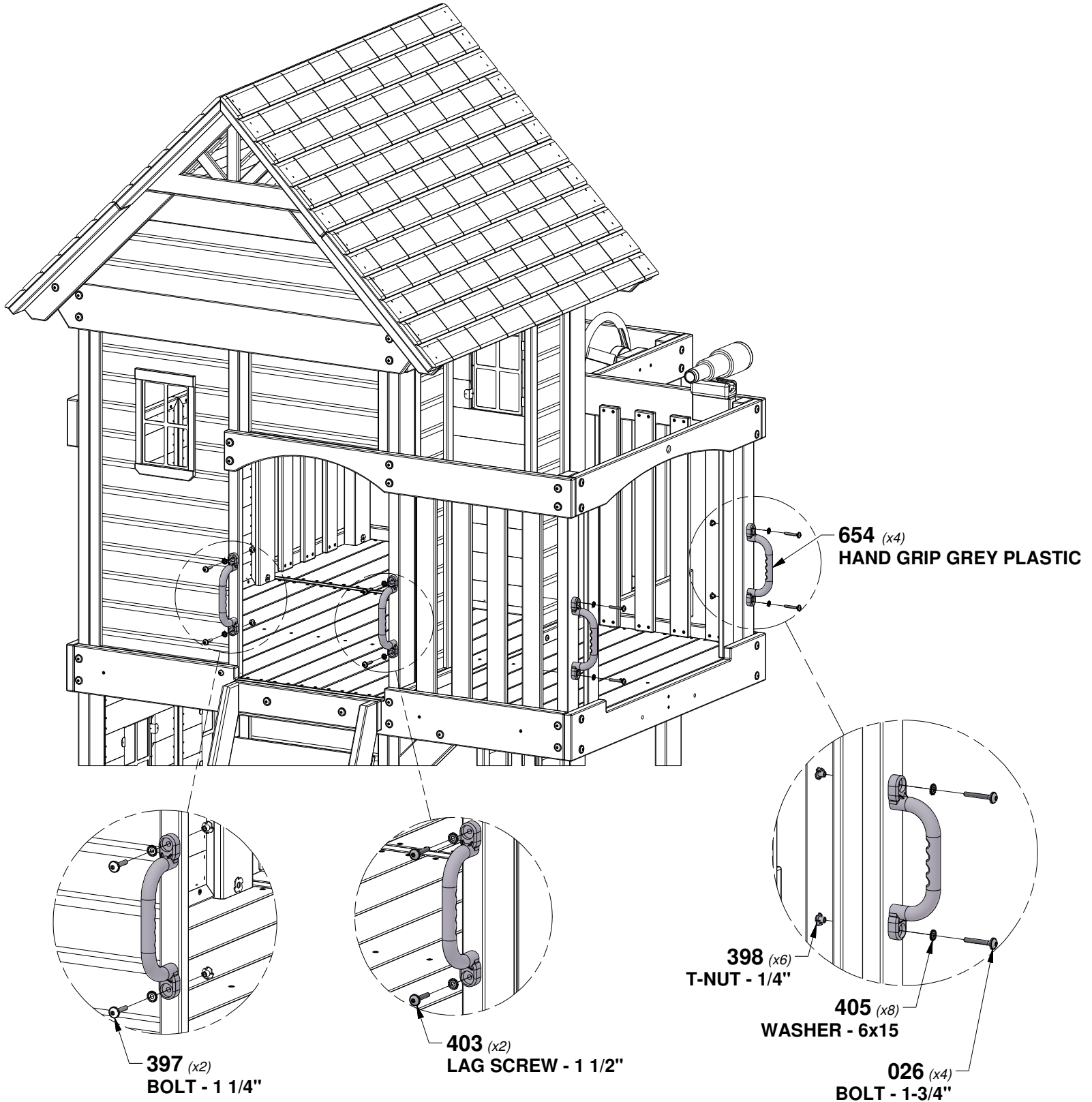

STEP 51 - FORT ASSEMBLY

QTY	PART NUMBER	DESCRIPTION
8	H100202	SCREW PWH 8x5/8 BLK

TOP

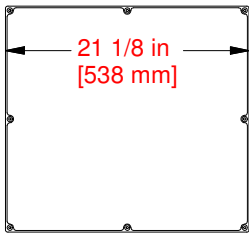

**A6P00324 CHALK BOARD
(x1) LARGE**

TIP:
CENTER CHALK BOARD ON WALL AS SHOWN.

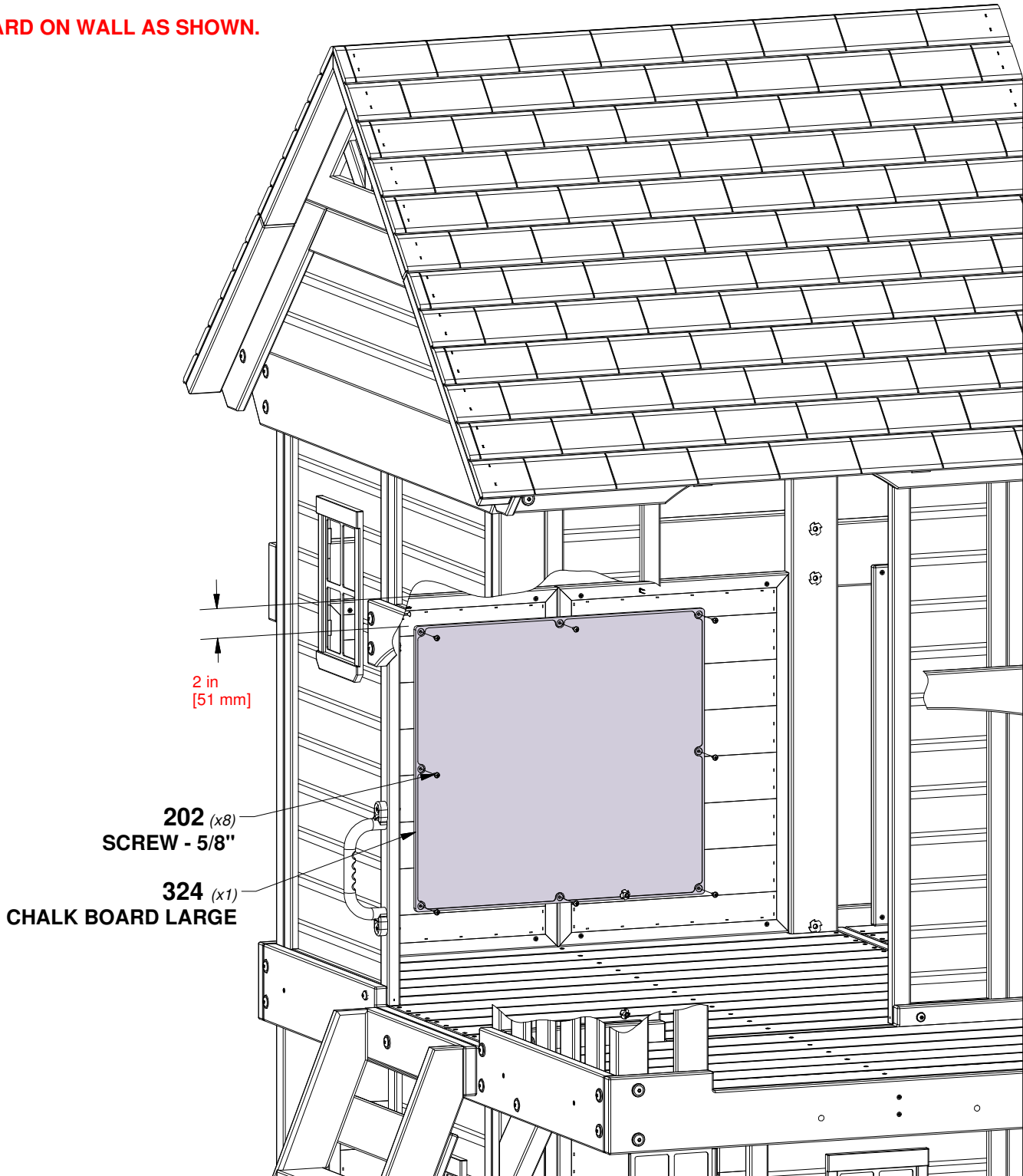

STEP 1 - FINAL ASSEMBLY

QTY	PART NUMBER	DESCRIPTION
2	H100198	WASHER LOCK EXT 8x19 BLK
2	H100378	BOLT WH 5/16x1 3/4 BLK

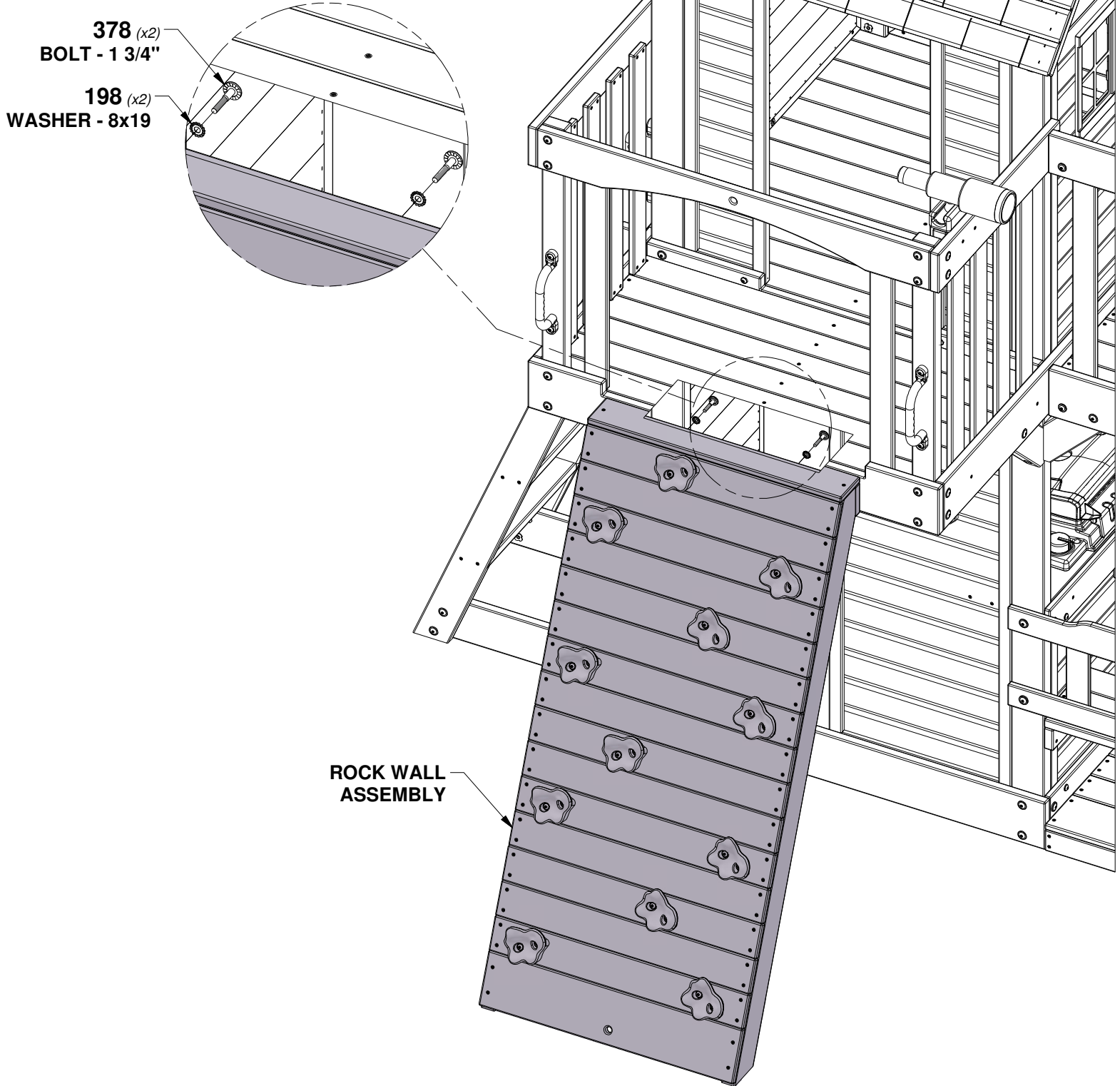

STEP 2 - FINAL ASSEMBLY

A6P00537
(x1) CLIMBING ROPE

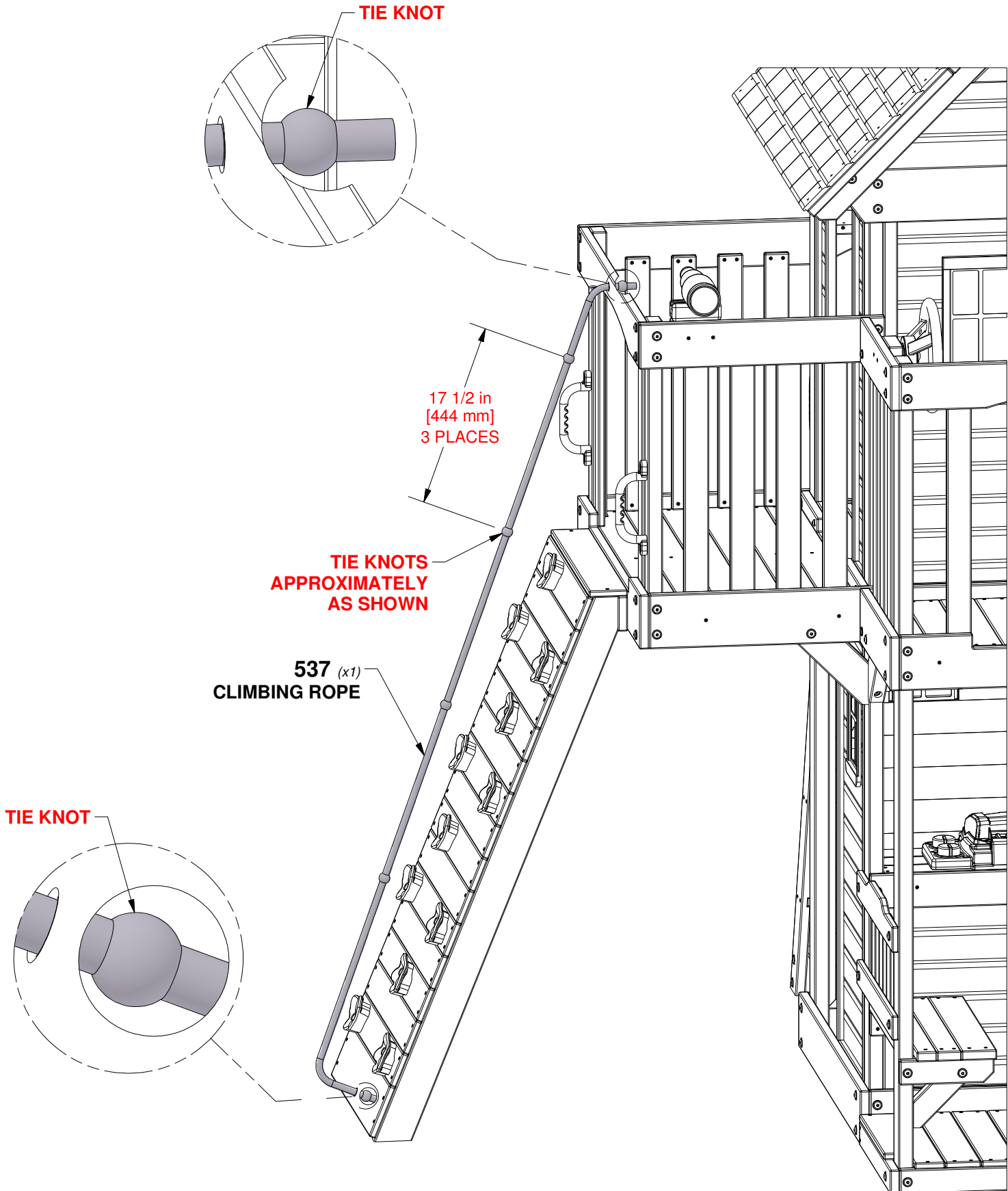

STEP 3 - FINAL ASSEMBLY

QTY	PART NUMBER	DESCRIPTION
2	H100379	T-NUT 5/16 BLK
2	H100468	BOLT WH 5/16x1 BLK

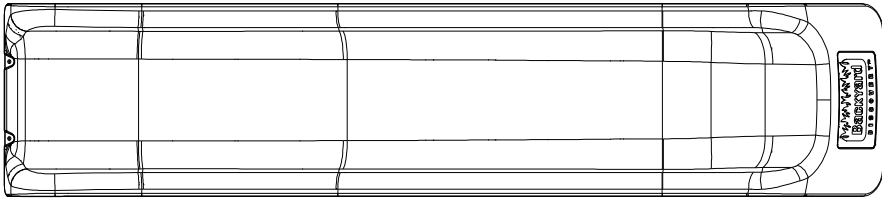

A6P00554
(x1) **8' BLOW MOLDED SLIDE - GREY**

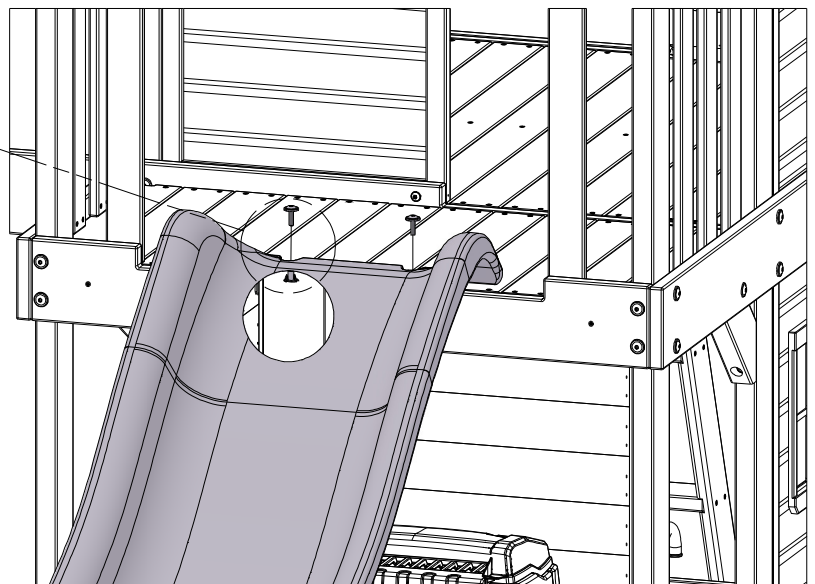
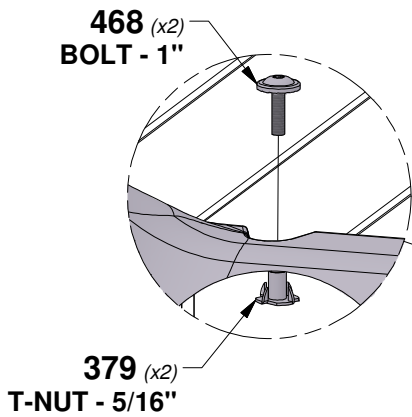
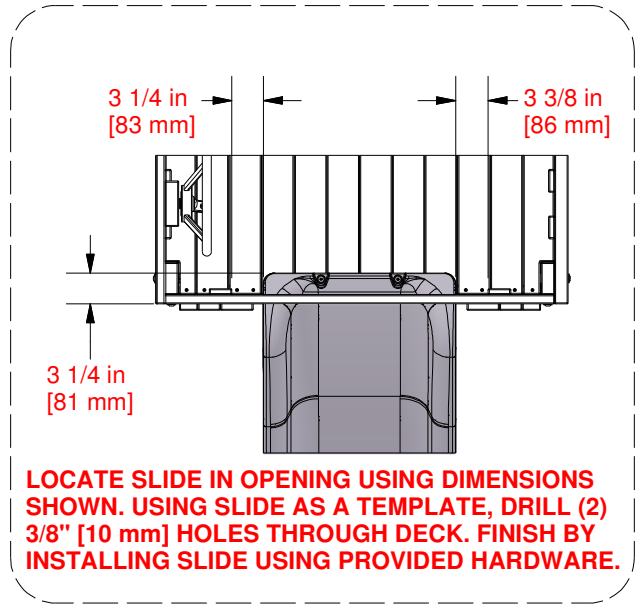
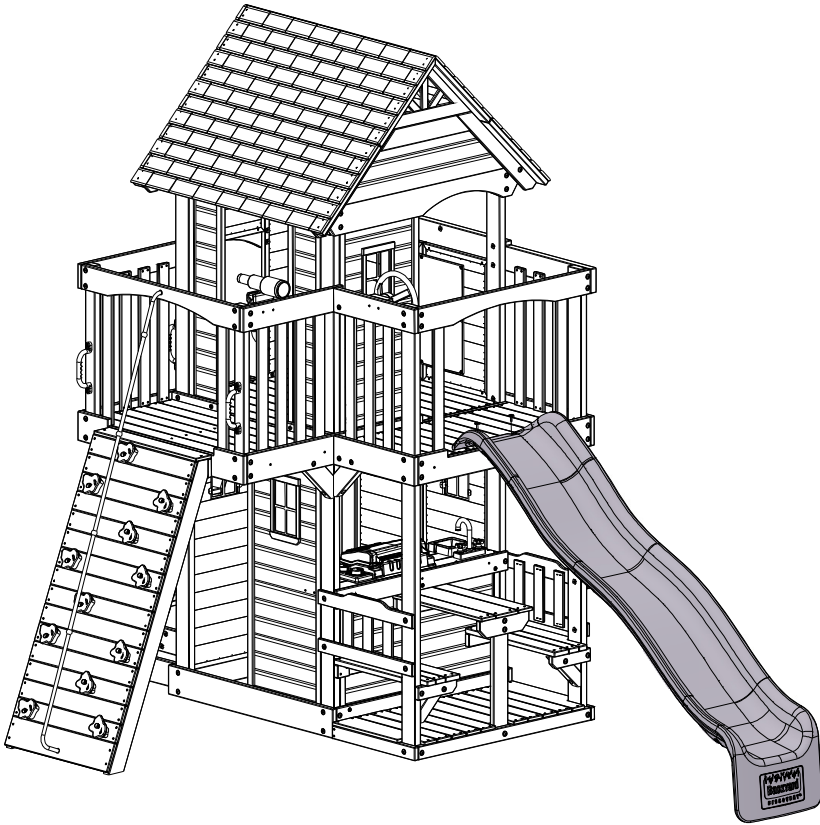

STEP 4 - FINAL ASSEMBLY

QTY	PART NUMBER	DESCRIPTION
4	H100477	WASHER SPLIT 5/16 BLK
4	H100478	WASHER FLAT 8x27 BLK
4	H100498	BOLT HEX 5/16x1-1/2 - BLK

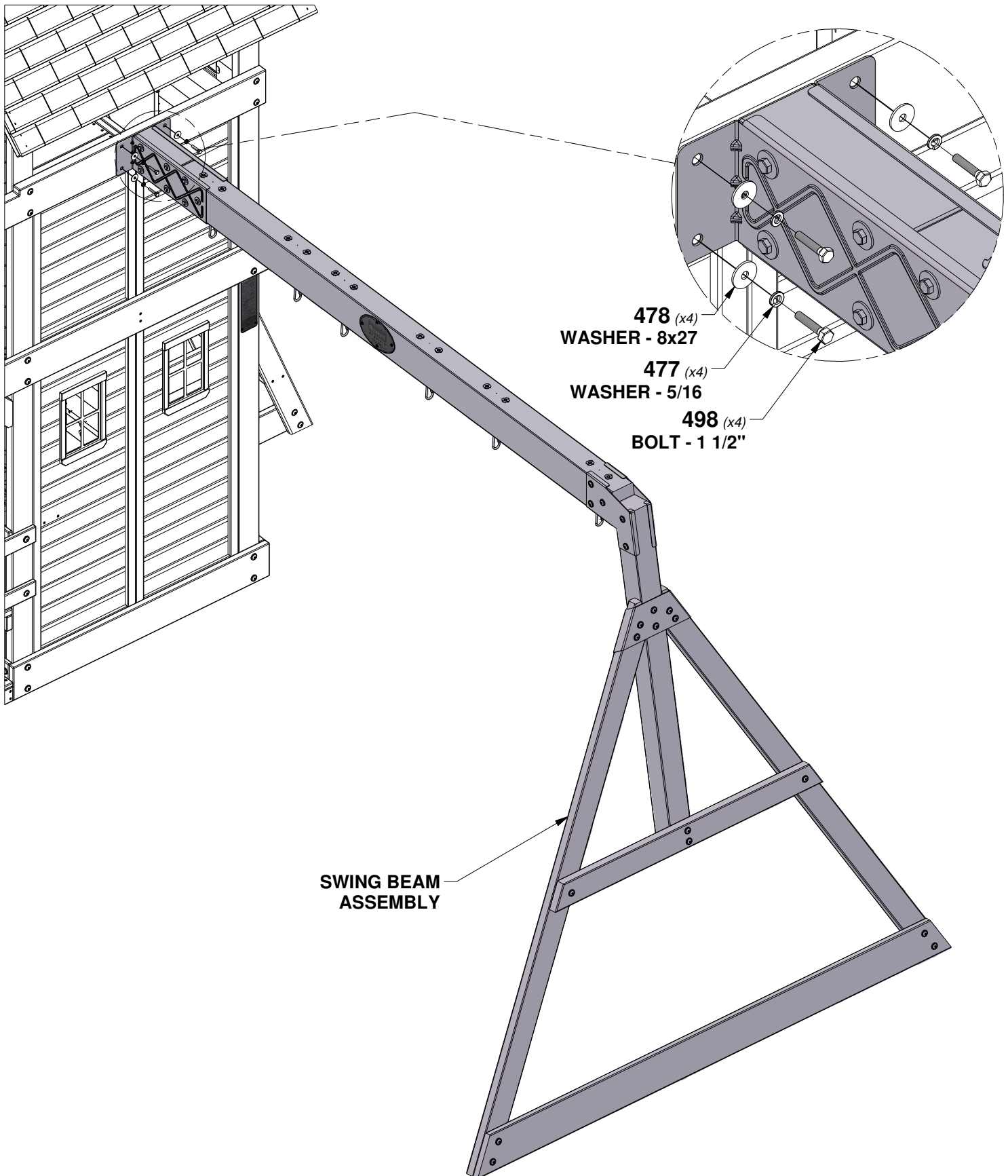

STEP 1 - WEB SWING ASSEMBLY

QTY	PART NUMBER	DESCRIPTION
4	H100831	NUT BARREL PTH BLK 1/4x3/4
4	H100832	BOLT PTH 1/4x3/4

IMPORTANT: SLIDE ROPE LOOPS OVER TUBE ENDS FIRST!

SLIDE NARROW END OF TUBES INTO LARGER OPENING AFTER SLIDING ROPE LOOPS ONTO TUBES.

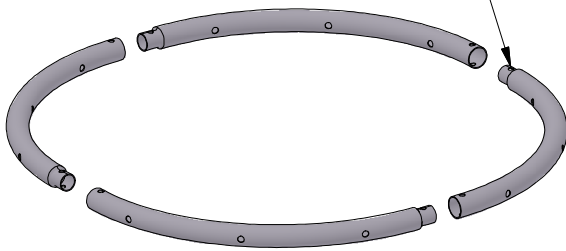

NOTE: ROPE WEBBING NOT SHOWN IN ILLUSTRATION FOR CLARITY.

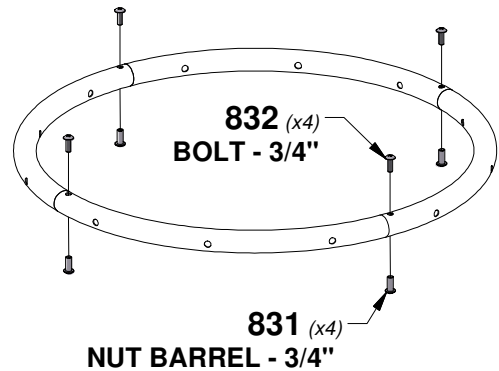

NOTE: IT IS IMPORTANT THAT THE WEB SWING HANG LEVEL.

TO ENSURE STRAIGHT SWINGING MOTION, ADJUST BOTH "S" BRACKETS UNTIL WEB SEAT IS LEVEL.

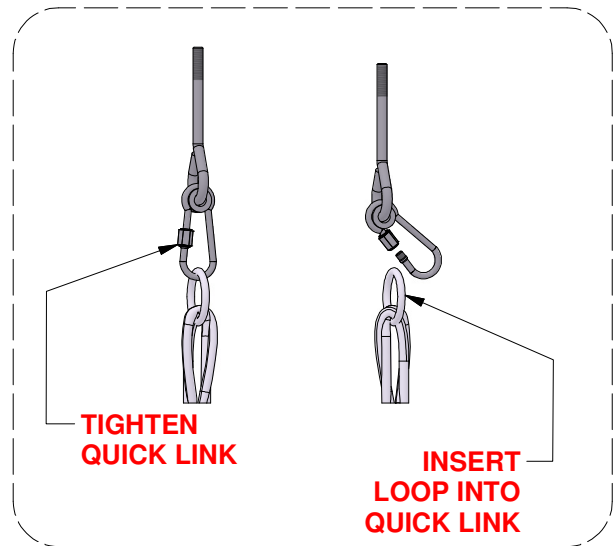

SWING MUST BE SET AT A MINIMUM OF 8 INCHES OFF THE GROUND WHEN INSTALLED.

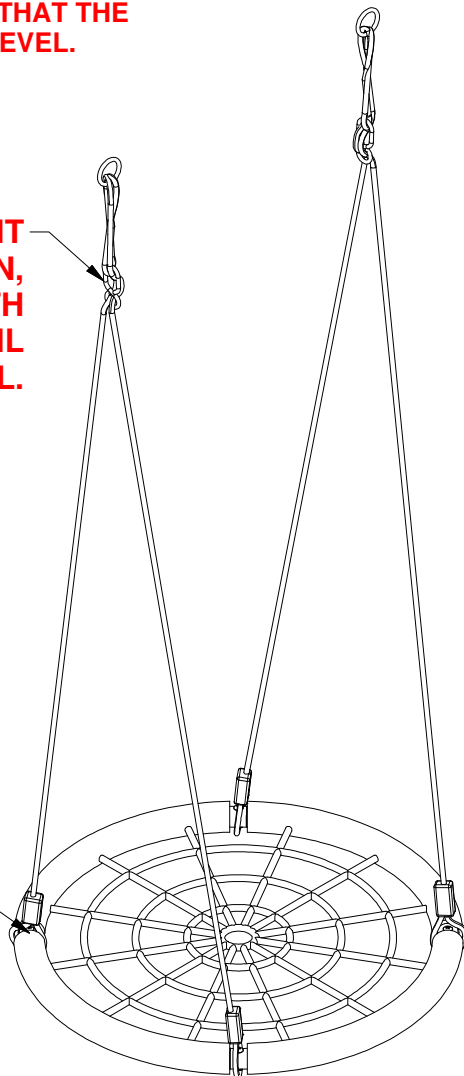

STEP 5 - FINAL ASSEMBLY



A4M02256
(x4) **CHAIN BLACK 51.25"**

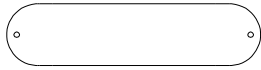

A6P00595
(x2) **SWING SEAT GREY 22"**



A4M00633
(x4) **QUICK LINK BLK**



A4M01126
(x1) **26" WEB SWING**

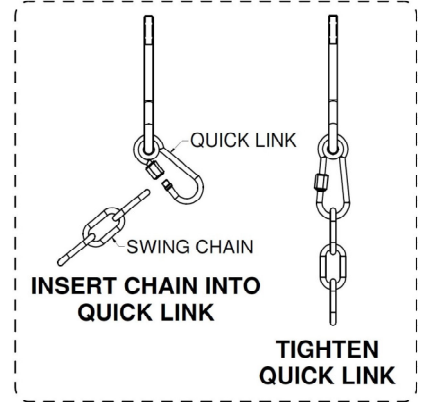
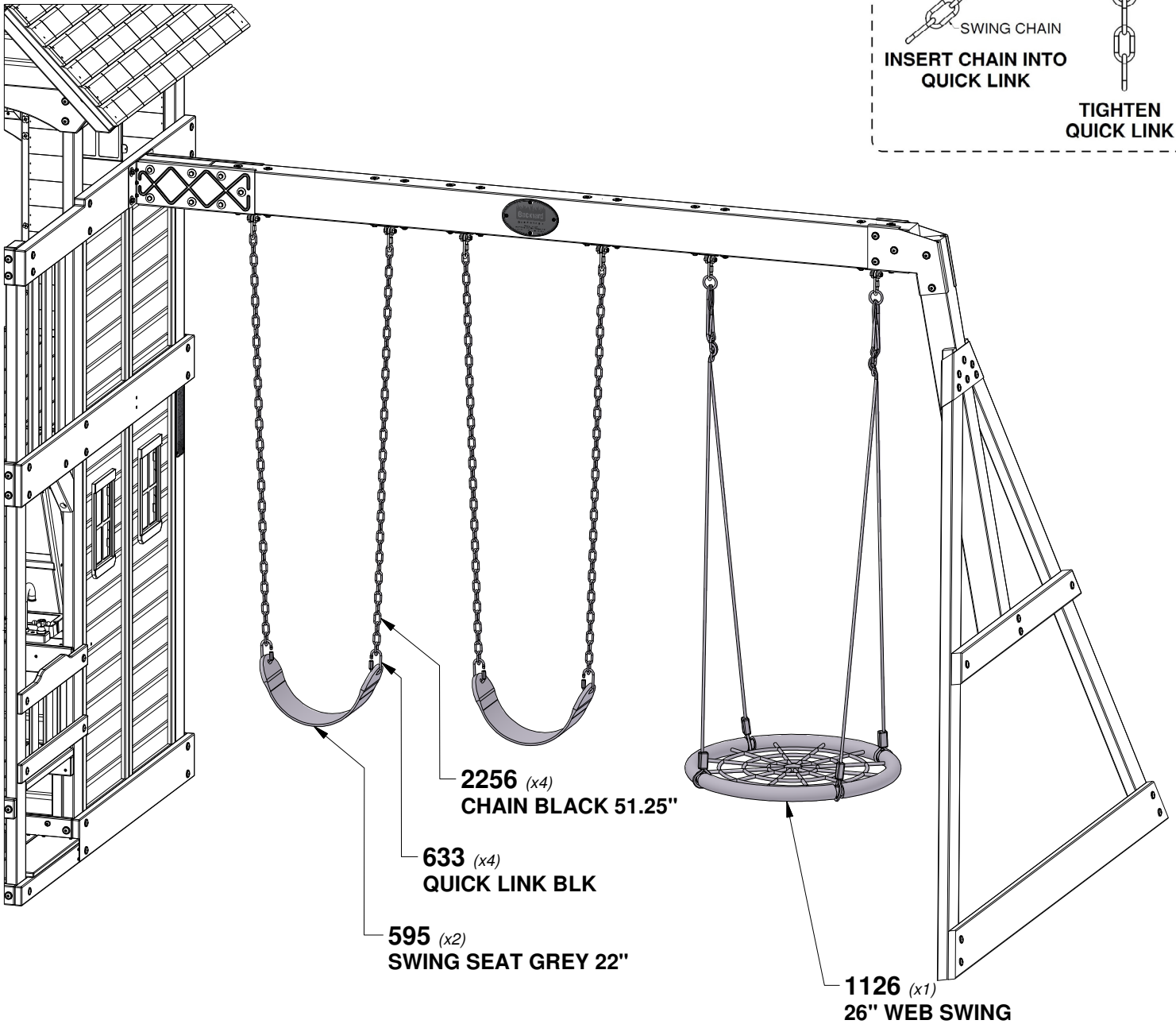

STEP 6 - FINAL ASSEMBLY

QTY	PART NUMBER	DESCRIPTION
6	H100379	T-NUT 5/16 BLK
6	H100459	BOLT WH 5/16x1 1/4 BLK

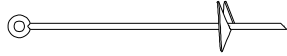

A4M02252 AUGER GROUND STAKE
(x6)

TWIST GROUND STAKE INTO GROUND AT LOCATIONS SHOWN. USING AUGER STAKE AS A GUIDE, DRILL A 3/8" [10mm] HOLE FOR HARDWARE.

