

Q



JAY R. SMITH MFG. CO. MEMBER OF MORRIS GROUP INTERNATIONAL



LOCATION

DRAWING NUMBER

s2120

SIZE

A

SCALE:

NONE

DATE:

5-17-85

APPROVED BY:

TD

CHECKED BY:

TD

DRAWN BY:

PJ

2120, 2125

WE CAN ASSUME NO RESPONSIBILITY FOR USE OF SUPERSEDED OR VOID DATA

FLOOR DRAINS

8 1/2" (215) ROUND TOPS

Free Area
13 SQ IN
(84) SQ CM

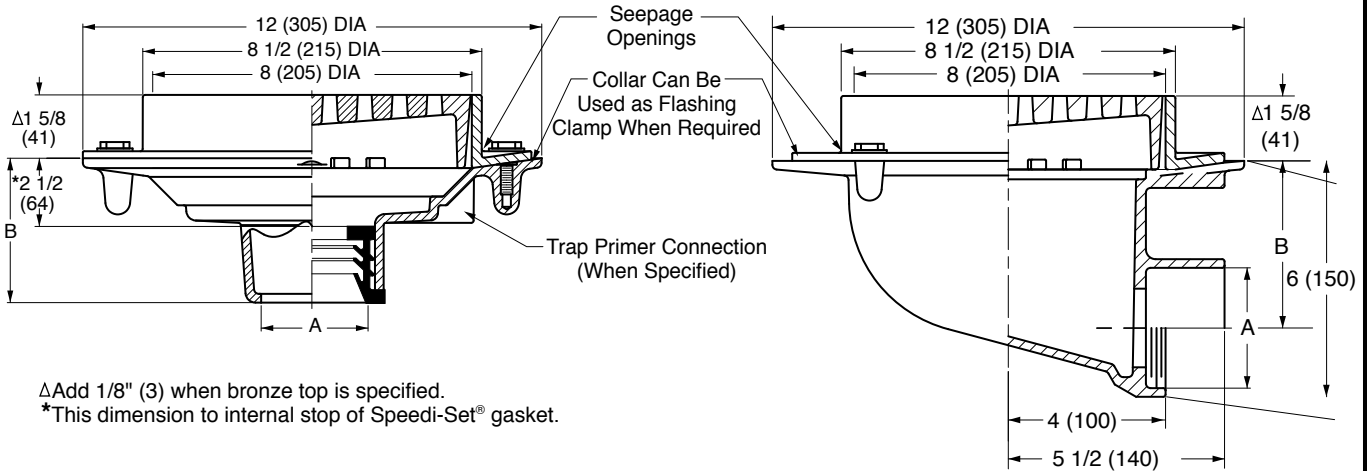

ΔAdd 1/8" (3) when bronze top is specified.
*This dimension to internal stop of Speedi-Set® gasket.

- Fig. 2120C.....CAULK OUTLET
- Fig. 2120Y.....NO-HUB OUTLET
- Fig. 2120T.....THREADED OUTLET

- Fig. 2125C.....CAULK OUTLET
- Fig. 2125T.....THREADED OUTLET

A SIZE	02 (50)	03 (75)	04 (100)	06 (150)
B	3 3/4 (95) for Caulk, NO-HUB, and Speedi-Set®, 2 (51) for Threaded		3 3/4 (95) NO-HUB Only	

A SIZE	02(50)	03(75)	04(100)
B	4 1/4(110)	3 3/4(95)	3 1/4(83)

REGULARLY FURNISHED:

Ducto Cast Iron Body and Flashing Collar with Medium Duty Cast Iron ADA Tractor Grate.

**For Heavy Duty: Specify Ductile Iron Grate-M.

VARIATIONS:

- Closure Plug -XP (Fig. 2110 only)
- Dome Grate -D
- Flat Bottom Strainer -FBS (Fig. 2120 only)
- L Speedi-Set® Service Weight (Fig. 2120 only)
- LXH Speedi-Set® Extra Heavy (Fig. 2120 only)
- NO-HUB Adaptor (Specify Fig. 2646Y) (Fig. 2125 only)
- Sediment Bucket -B
- Square Top -S
- Trap Primer Connection -P050 1/2" (13) & -P075 3/4" (19)
- Vandal Proof Grate -U
- Heel Proof Grate -Q45
- Quad Close Trap Seal (Specify Fig. 2692) (Fig. 2120 Only)

OPTIONAL MATERIALS:

- Ductile Iron Grate -M
- Galvanized Cast Iron -G
- Nickel Bronze Top -NB
- Polished Bronze Top -PB

NOTE: Dimensions shown in parentheses are in millimeters.
•Not available on Fig. 2120T threaded outlet drain.

FIGURE NUMBER

Q 3-10-23
P 1-23-23
N 5-27-21
M 9-11-19

Added ® to "Speedi-Set"
Added ADA
Rem. Note & Added to Reg. Fur.
Rev. Fig.Opts and Variations

KK
KK
KK
MW

CL
JT
JT
CL

WEIGHT POUNDS

VOLUME CUBIC FEET

FIGURE NUMBER

2120, 2125

REV. DATE DESCRIPTION BY CKD.



WARNING: Cancer and Reproductive Harm - www.P65Warnings.ca.gov