









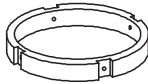

ASSEMBLY INSTRUCTION

24"H SWIVEL COUNTER HEIGHT CHAIR (VERTICAL DESIGN)
29"H SWIVEL BAR HEIGHT CHAIR (VERTICAL DESIGN)

| | | | | |
|--|---|---|---|---|
| A Backrest  1pc | B Cushion Seat  1pc | C Footrest  1pc | D Apron With Swivel Plate  1pc | E Chair Leg  4pcs |
| F Bolt 1/4" x 1-3/8"  16pcs | G Bolt 1/4" x 1-3/4"  6pcs | H Lock Washer 1/4" x 1/2"  18pcs | I Flat Washer 1/4" x 1/2"  12pcs | J Flat Washer 1/4" x 5/8"  10pcs |
| K Allen Wrench 5/32"  1pc | | | | |

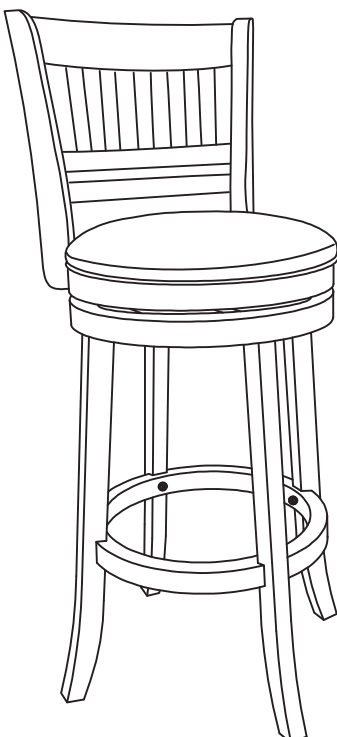

This page lists all the contents included in the box. Please take the time to identify the hardware as well as the individual components to this product. As you unpack and prepare for assembly, place the contents on a carpeted or padded area to protect them from damage.

- 1** Attach the Chair Leg (E) to the Apron With Swivel Plate (D), then attach the Footrest (C) to the Chair Leg (E) using Bolt (F), Lock Washer (H) and Flat Washer (I) with Allen Wrench (K).

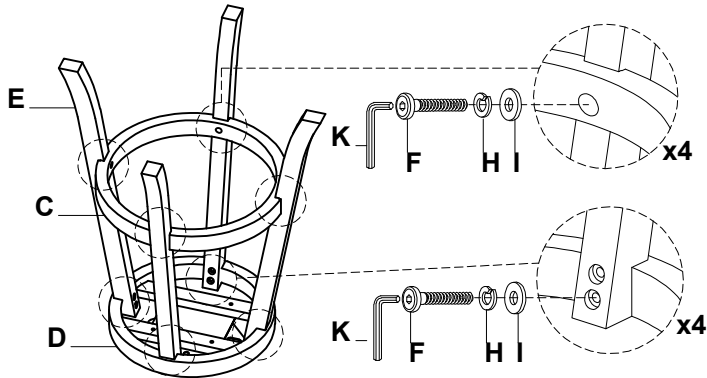

Take the Allen Wrench, and turn the bolts until the legs are secured. **DO NOT TIGHTEN COMPLETELY.** Stop when you feel you are adding force to tighten the bolt.

- 2** Invert the Cushion Seat (B) and place it on a stable, raised surface (i.e. Table). Attach the Backrest (A) to the Cushion Seat (B) using Bolt (G), Lock Washer (H) and Flat Washer (J) with Allen Wrench (K).

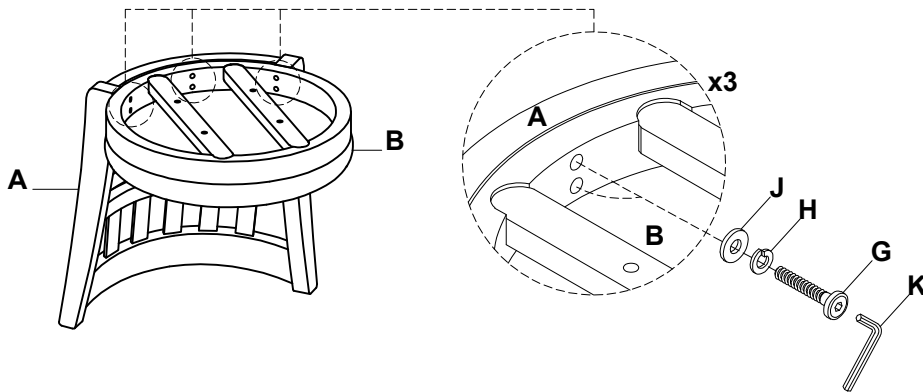

- 3** Keep the Backrest (A) and Cushion Seat (B) inverted on a stable raised surface. Attach the Swivel Plate located on the Apron With Swivel Plate (D) to the Cushion Seat (B) using Bolt (F) and Flat Washer (J) with Allen Wrench (K).

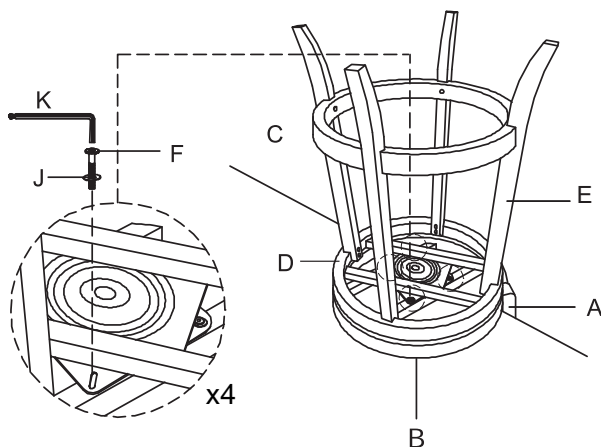

Stand chair up on an even surface and check that it is balanced. If there is a slight wobble, apply downward pressure in the corner where a leg is uneven. Keeping pressure in that corner, tighten all bolts. If balanced, apply downward pressure evenly in the center and tighten all bolts. Do not over-tighten beyond hole depth.

Helpful Tip:
Instead of applying downward pressure while reaching under to tighten bolts, have someone sit in the chair while you tighten the bolts.

CLEANING & CARE

Treat surfaces with care. Surfaces are resistant to scratches but are not scratch resistant. Clean surfaces with a dry or damp soft cloth. Do not use abrasive cleaners. Hardware may loosen over time. Periodically check that all connections are tight.