

# ASSEMBLY INSTRUCTION

## CHANNEL QUEEN HEADBOARD

**A** Headboard

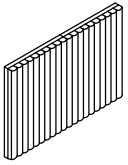

1 pc

**B** Left Leg

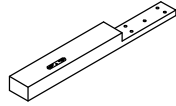

1 pc

**C** Right Leg

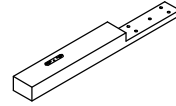

1 pc

**D** Support Bar

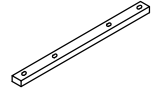

2 pcs

**E** Allen Bolt  
Ø5/16" x 50mm



18 pcs

**F** Allen Bolt  
Ø5/16" x 88mm



2 pcs

**G** Spring Washer  
Ø5/16"



20 pcs

**H** Hex Nut  
Ø5/16"



2 pcs

**I** Flat Washer  
Ø5/16" x 22 mm



22 pcs

**J** Open Wrench  
Ø5/16"



1 pc

**K** Allen Key  
4mm

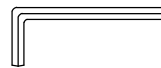

1 pc

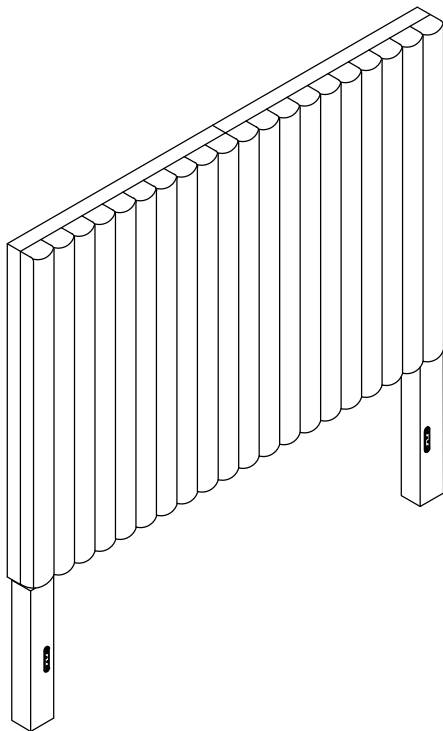

This page lists all the contents included in the box. Please take the time to identify the hardware as well as the individual components to this product. As you unpack and prepare for assembly, place the contents on a carpeted or padded area to protect them from damage.

### IMPORTANT NOTE:

1. Do not tighten all screws / bolts until all completely assembled.
2. Keep all hardware parts out of reach of children.

**\*\*\* Do not tighten screws & bolts until the entire unit is completely assembled.**

- 1** Open the Black Woven Fabric and connect the Headboard (A) by using Allen Bolt (F), Spring Washer (G), Flat Washer (I) and Hex Nut (H) and tightening with Open Wrench (J).

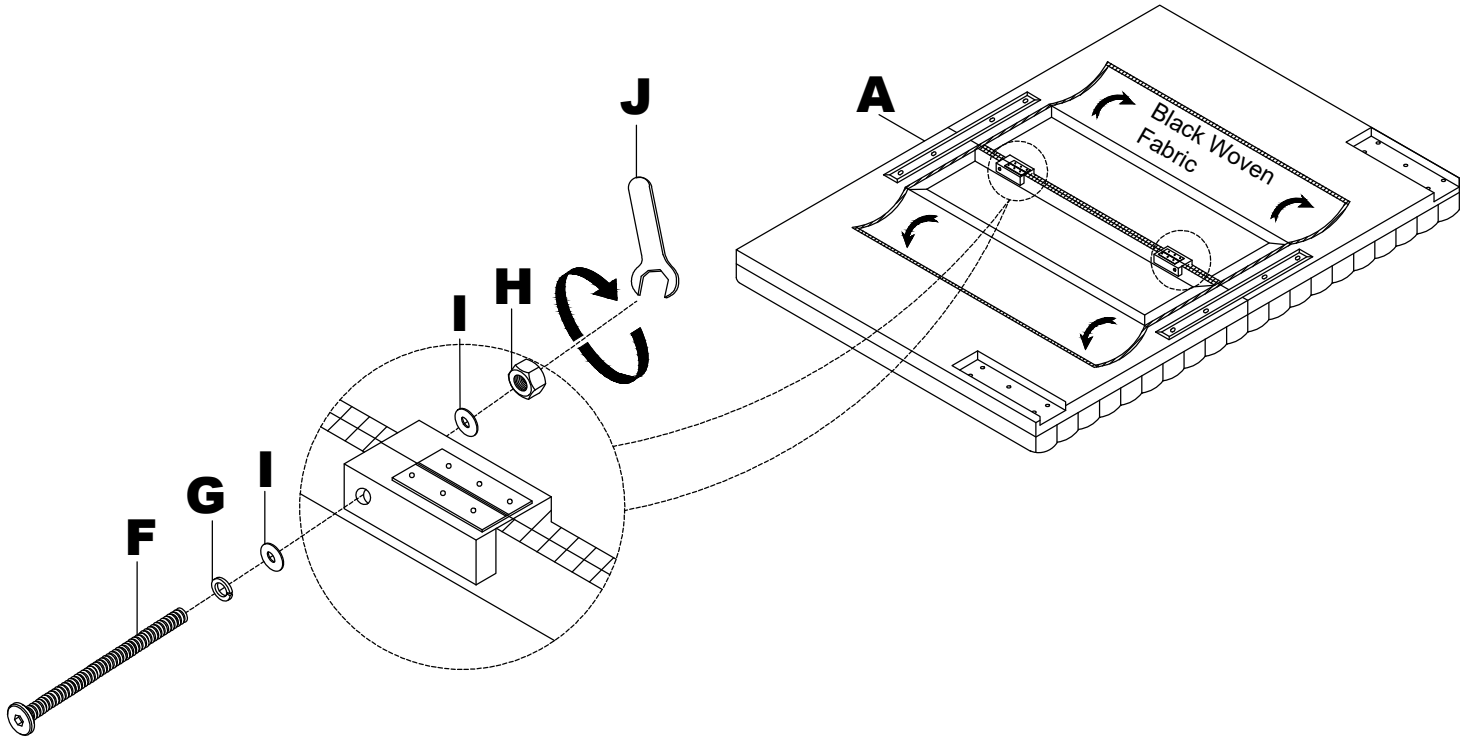

- 2** Close the Black Woven Fabric of Headboard (A) to position.

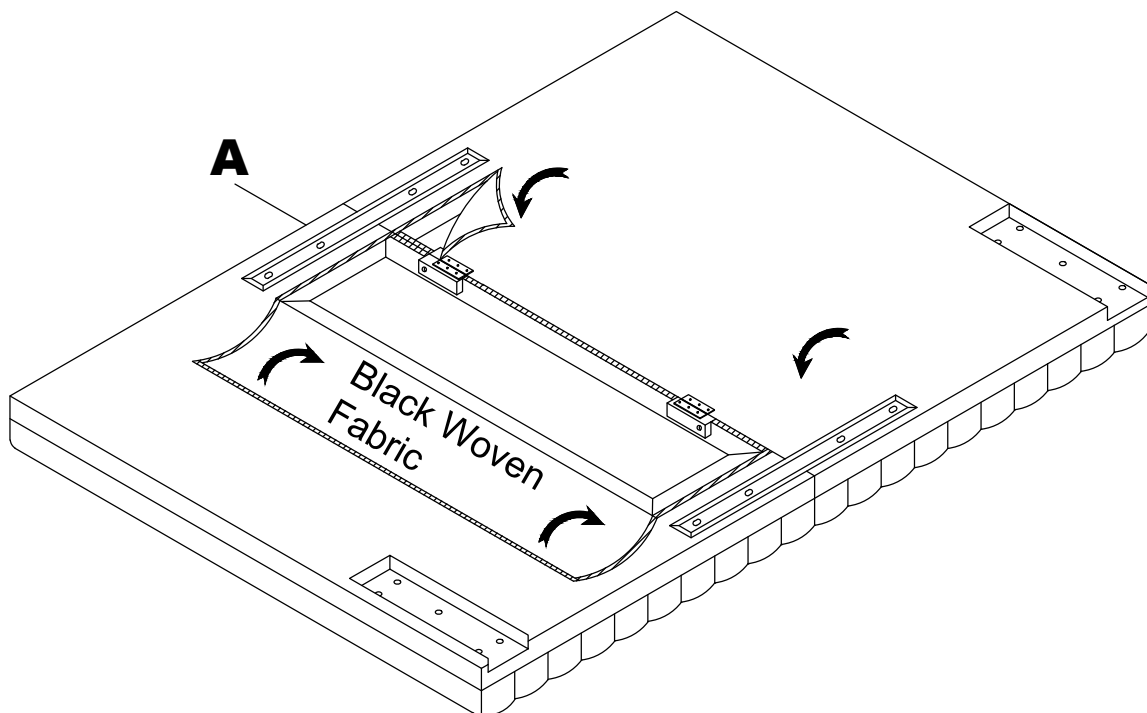

**\*\*\* Do not tighten screws & bolts until the entire unit is completely assembled.**

- 3** Attach Support Bar (D) to Headboard (A) by using Allen Bolt (E), Spring Washer (G) and Flat Washer (I) and tightening with Allen Key (K).

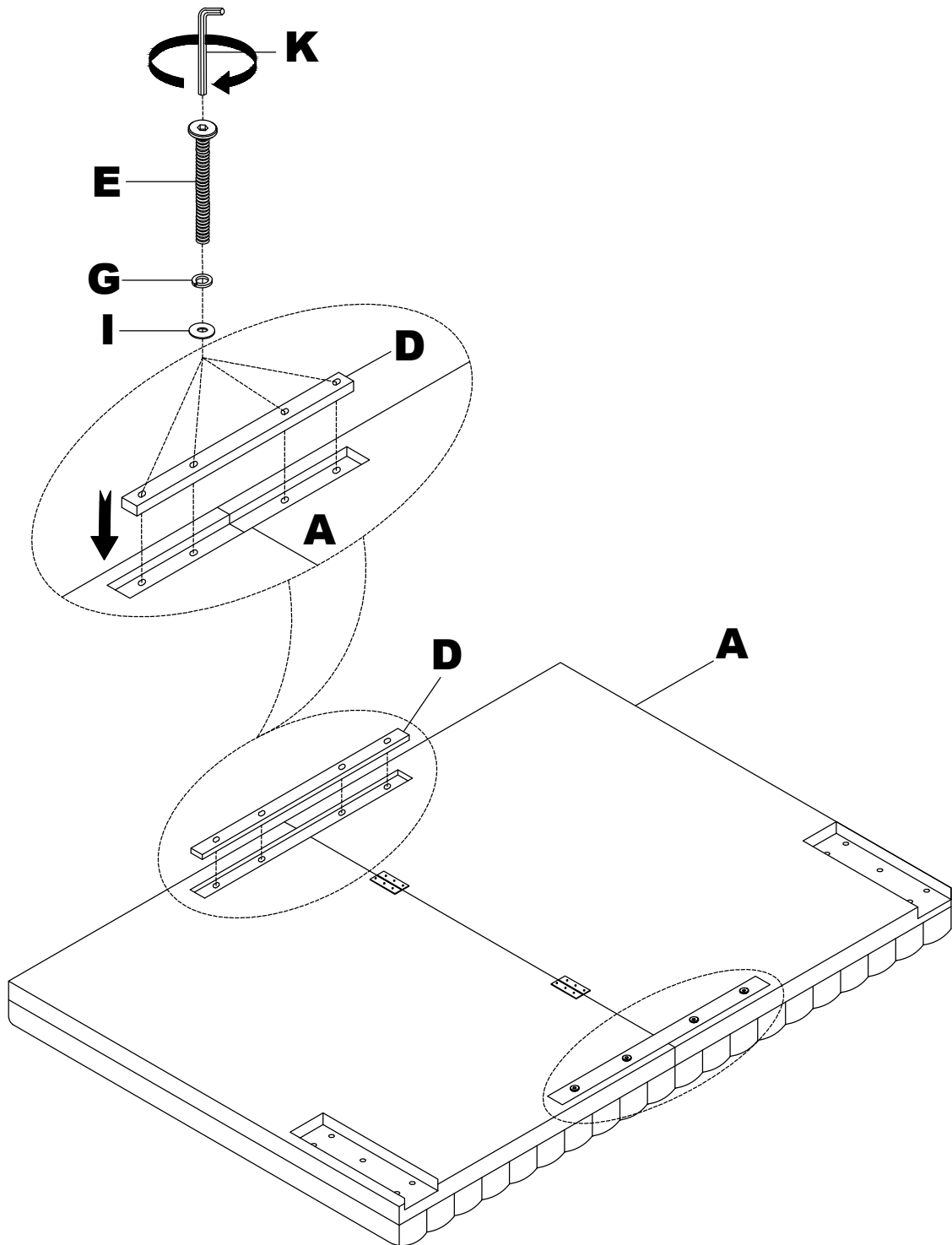

**\*\*\* Do not tighten screws & bolts until the entire unit is completely assembled.**

- 4** Attach Left & Right Leg (B&C) to Headboard (A) by using Allen Bolt (E), Spring Washer (G) and Flat Washer (I) and tightening with Allen Key (K).

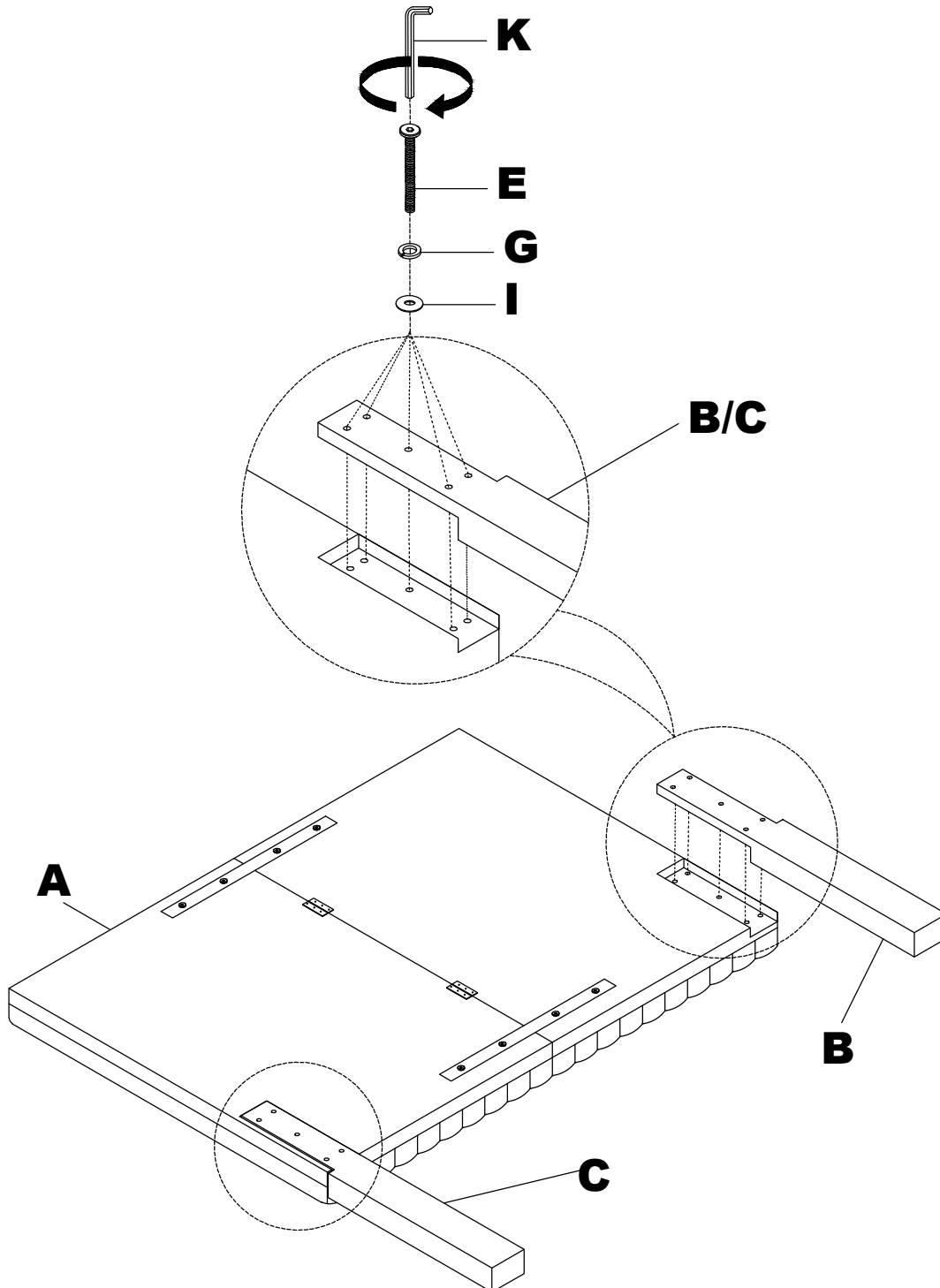





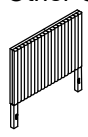
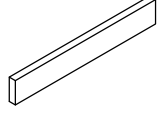
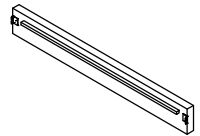

#### **Cleaning & Care**

Treat surface with care. Surface is resistant to scratches but is not scratch resistant. Clean surfaces with a dry or damp soft cloth. Do not use abrasive cleaners. Hardware may loosen over time. Periodically check that all connections are tight.

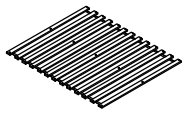
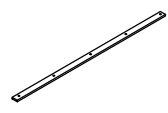
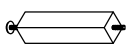
# ASSEMBLY INSTRUCTION

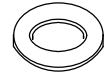
## CHANNEL QUEEN BED

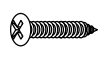
<b>A</b> Headboard (In The Other Carton)  1 pc	<b>B</b> Footboard  1 pc	<b>C</b> Side Rail  2 pcs	<b>D</b> Leg  2 pcs
<b>E</b> Slat Roll  1 set	<b>F</b> Center Slat Support  1 pc	<b>G</b> Support Leg  5 pcs	<b>H</b> Allen Bolt Ø5/16" x 50mm  4 pcs
<b>I</b> Spring Washer Ø5/16"  4 pcs	<b>J</b> Flat Washer Ø5/16" x 19 mm  4 pcs	<b>K</b> Allen Key 4mm  1 pc	<b>L</b> Screw Ø8 x 30mm  26 pcs

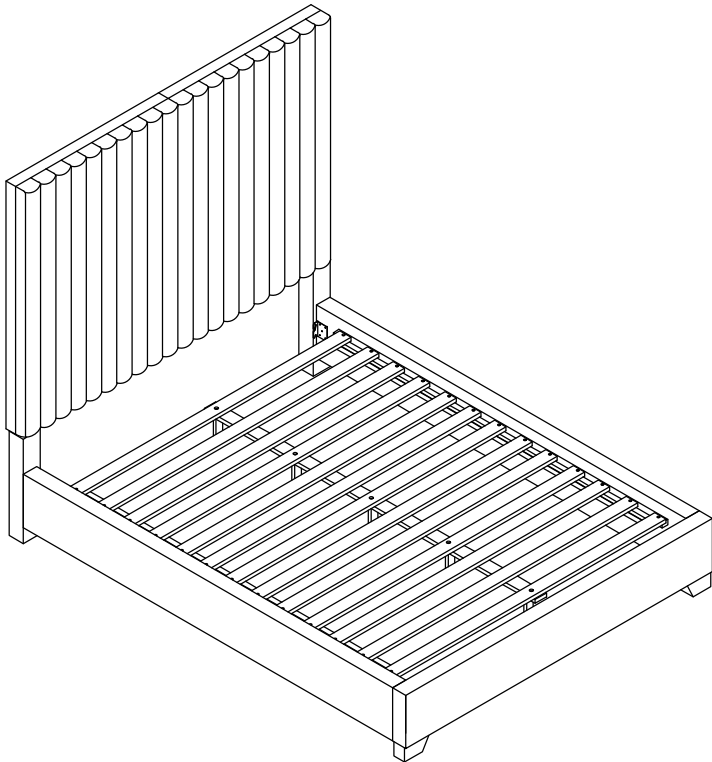

This page lists all the contents included in the box. Please take the time to identify the hardware as well as the individual components to this product. As you unpack and prepare for assembly, place the contents on a carpeted or padded area to protect them from damage.

### IMPORTANT NOTE:

1. Do not tighten all screws / bolts until all completely assembled.
2. Keep all hardware parts out of reach of children.

**\*\*\* Do not tighten screws & bolts until the entire unit is completely assembled.**

- 1** Attach Leg (D) to Footboard (B) by using Allen Bolt (H), Spring Washer (I) and Flat Washer (J) and tightening with Allen Key (K).

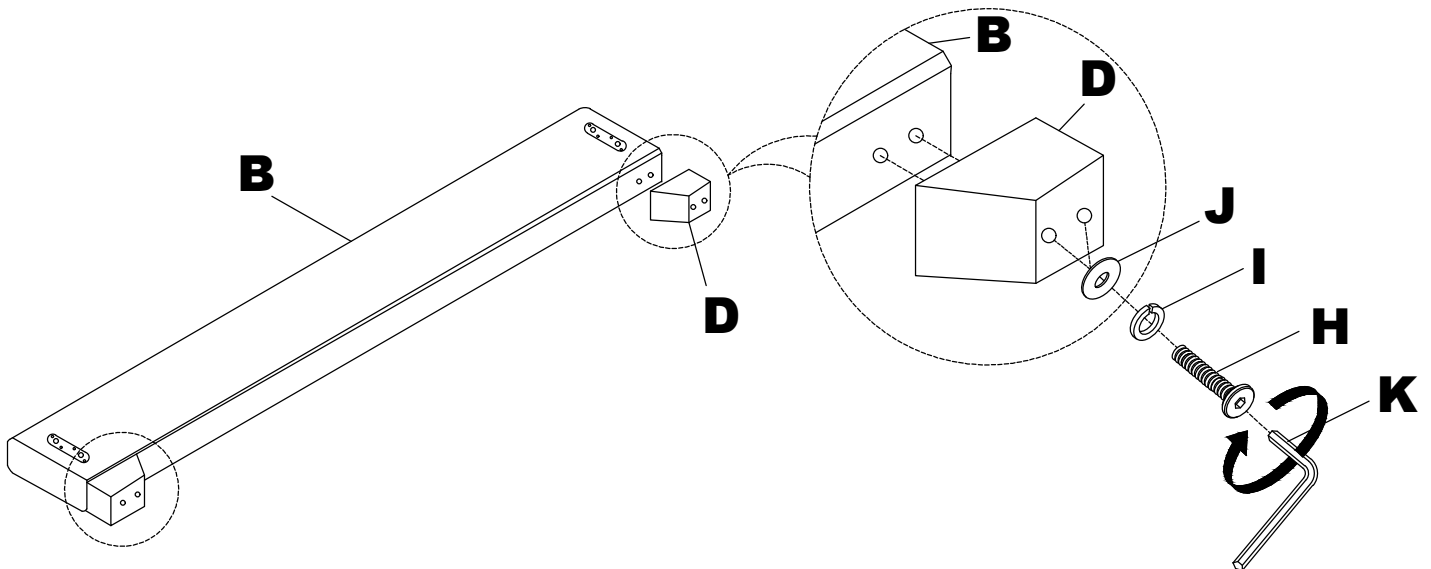

- 2** Unfasten the Bolts, Spring Washers and Flat Washers on Left & Right Leg of Headboard (A), then attach Side Rail (C) to Headboard (A) using all of these hardware and tighten with Allen Key (K).  
Remark: Do not tighten the bolts until screw Slat Roll (E) well on the Side Rail (C).

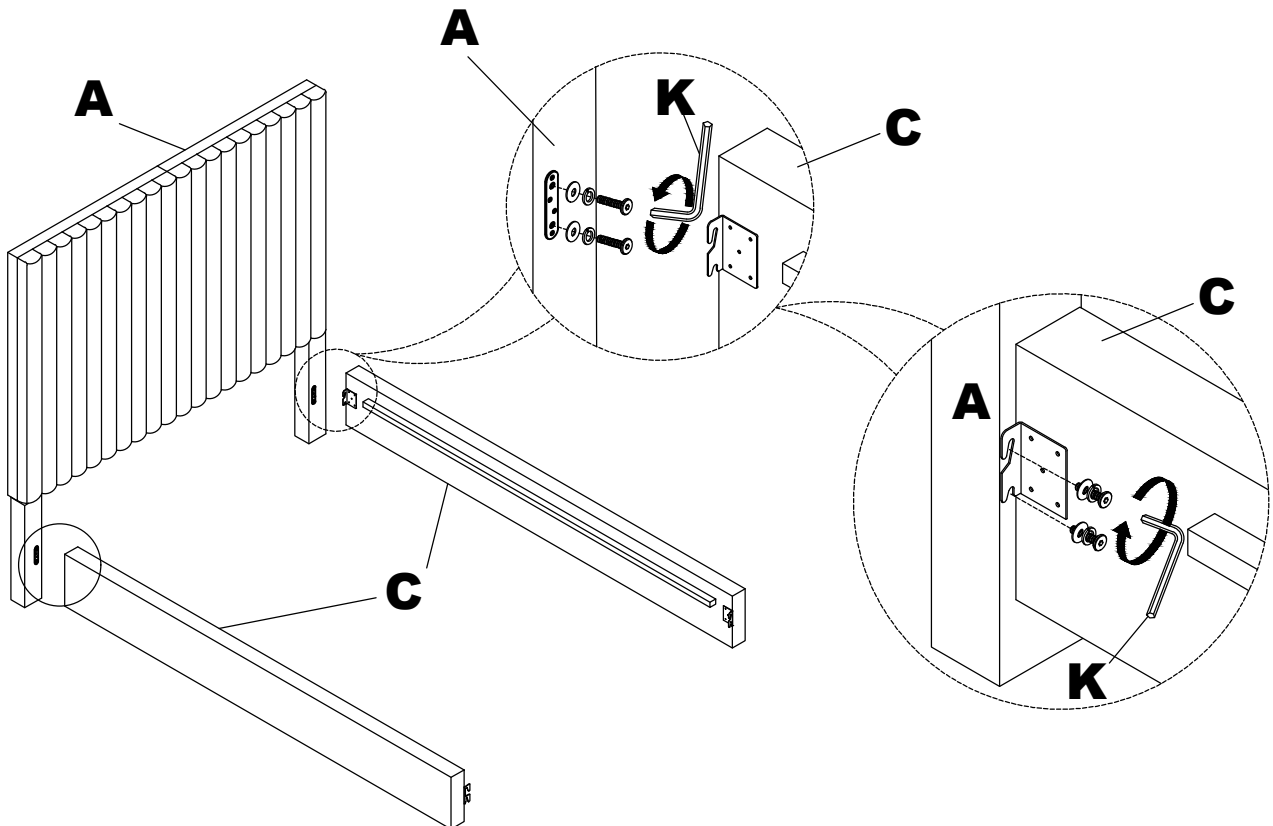

**\*\*\* Do not tighten screws & bolts until the entire unit is completely assembled.**

- 3** Unfasten the Bolts, Spring Washers and Flat Washers on Footboard (B), then attach Side Rail (C) to Footboard (B) using all of these hardware and tighten with Allen Key (K).  
Remark: Do not tighten the bolts until screw Slat Roll (E) well on the Side Rail (C).

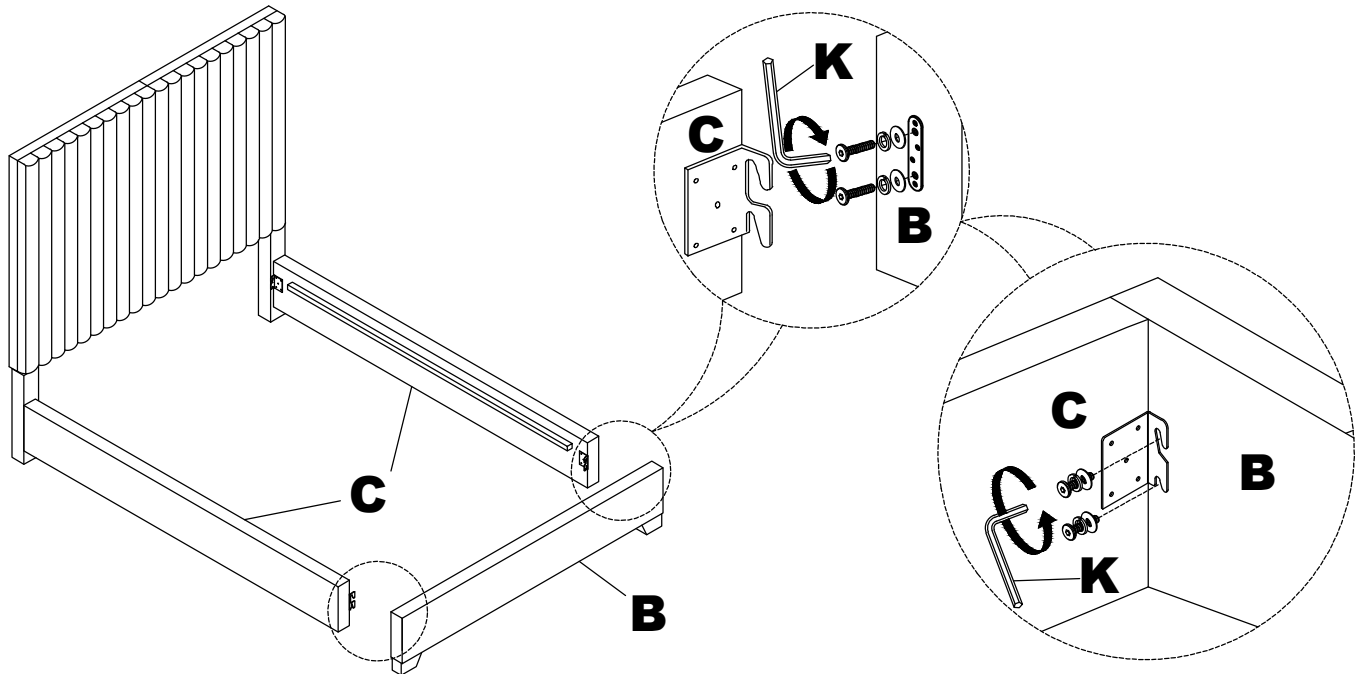

- 4** Attach Support Leg (G) to Center Slat Support (F) and Slat Roll (E). Then attach Slat Roll (E) on Side Rail (C) using Screw (L) with Phillips Head Screwdriver (not provided).

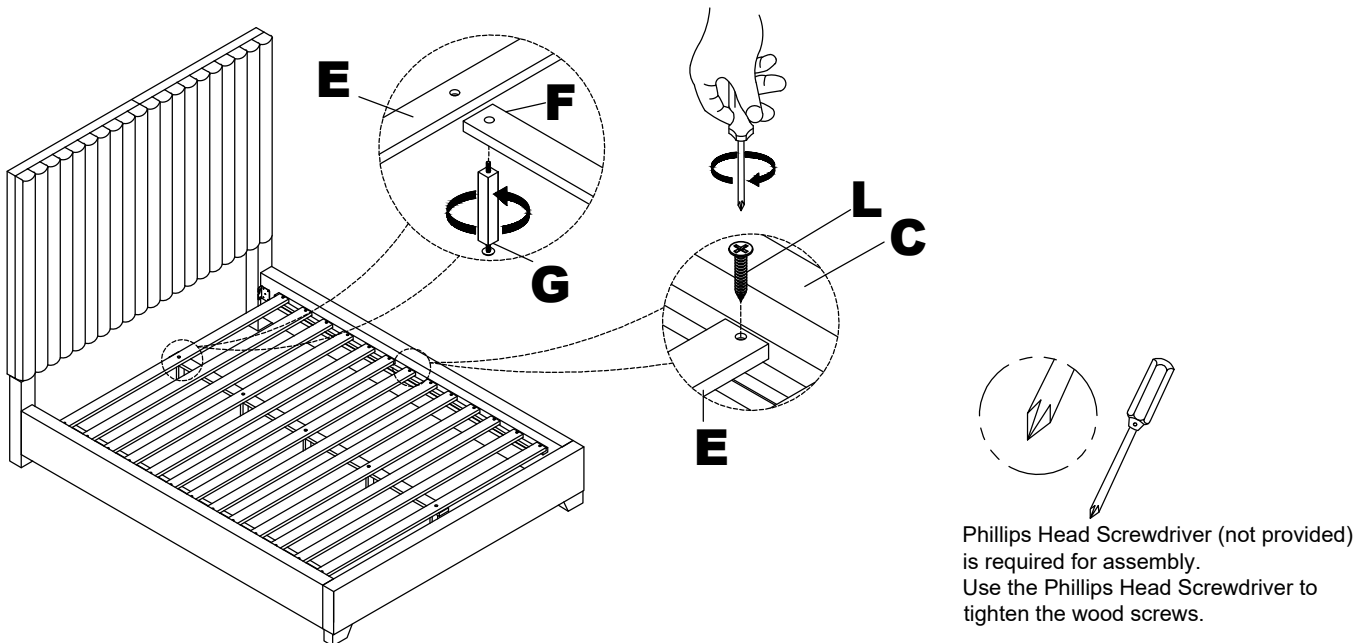

### Cleaning & Care

Treat surface with care. Surface is resistant to scratches but is not scratch resistant. Clean surfaces with a dry or damp soft cloth. Do not use abrasive cleaners. Hardware may loosen over time. Periodically check that all connections are tight.