

# Installation and Care Guide

## Bath- or Deck-Mount Spout

Français, page "Français-1"  
Español, página "Español-1"

THE BOLD LOOK  
OF **KOHLER**®

1317800-2-A

## Tools and Materials

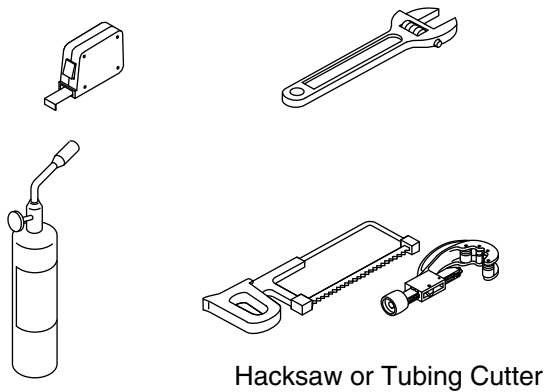

**Plus:**  
• Rag

## Before You Begin



**WARNING: Risk of personal injury.** Do not install the bath faucet in an area where it may inadvertently be used for support by the bather.



**CAUTION: Risk of property damage.** Select a cutting tool appropriate for the deck/rim surface type. Refer to the surface manufacturer's instructions for the proper cutting procedures.

**IMPORTANT!** Do not install this spout to a bath valve other than the one included.

- Observe all local plumbing and building codes.
- Turn OFF the water supply.
- Protect the surface of the bath deck or rim during installation.

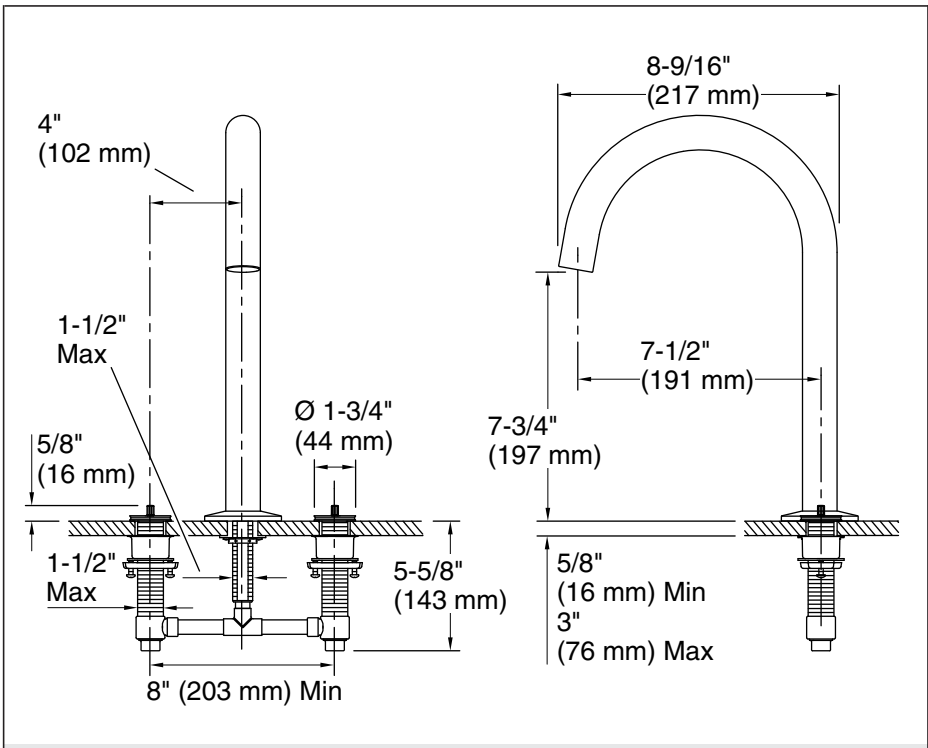

## Roughing-In

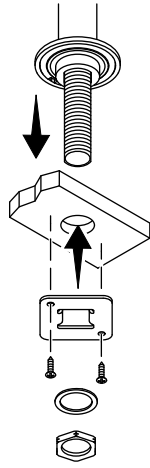

## 1. Install the Spout

- Insert the spout supply tube into the mounting hole.
- Orient the plate with the tabs up. Slide the plate onto the supply tube until flush with the underside of the deck/rim.
- Secure the plate to the underside of the deck/rim with the screws.
- Slide the flat washer onto the supply tube assembly, then thread the nut onto the supply tube assembly. Securely wrench tighten the nut.

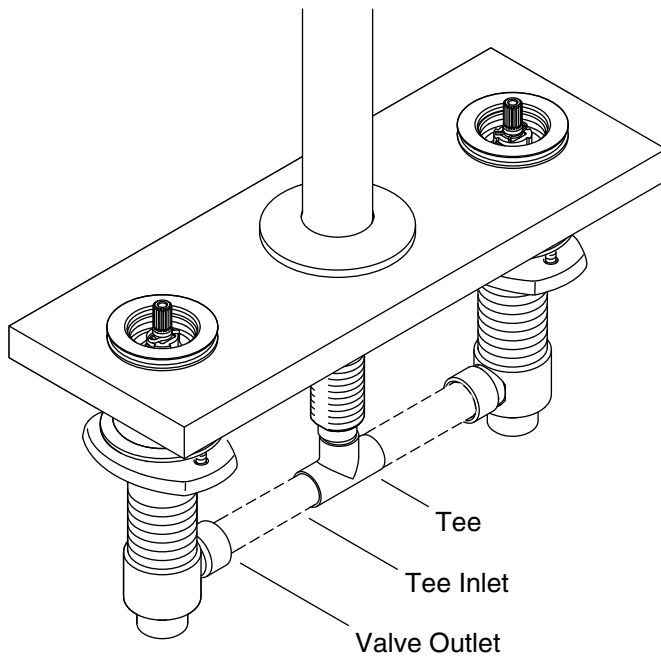

## 2. Install the Tubing

- Attach the tee to the spout tube.
- Measure the distance between the tee inlets and each valve body outlet.
- Cut the copper tubing to fit.
- Pivot the valve bodies, and install the two pieces of copper tubing.
- Confirm that the copper tubing has been cut to the correct length.

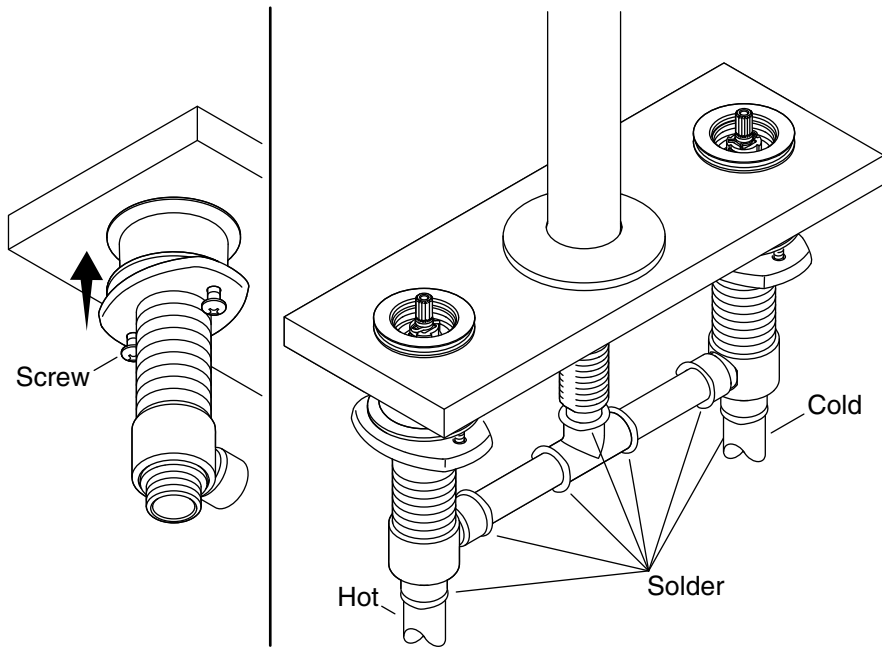

### 3. Connect the Valves

- Tighten the mounting hardware to secure each valve body to the deck or rim.
- Connect the hot and cold valve bodies to the hot and cold water supply lines.
- Connect the hot and cold supply lines to the hot and cold faucet valves.

**CAUTION: Risk of product damage.** Do not expose the internal spout components to excessive soldering heat. Wrap a wet rag around the supply tube before soldering the connections.

- Wrap a wet rag around the spout supply tube to protect the internal spout components from soldering heat.
- Solder the connections.

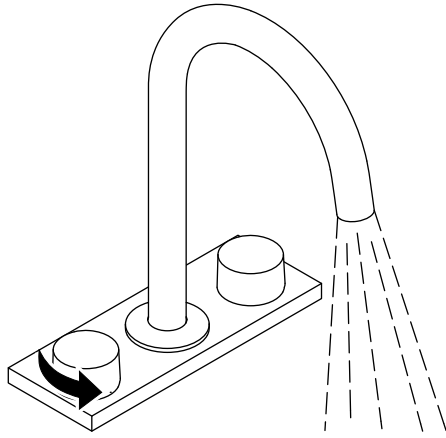

#### 4. Complete the Installation

- Install the handles according to the instructions.
- Turn ON the water supplies.
- Check for leaks at all connections. Repair as needed.
- Open both faucet valves to run water through the spout. Verify proper operation.

#### Care and Cleaning

For best results, keep the following in mind when caring for your KOHLER product:

- Use a mild detergent such as liquid dishwashing soap and warm water for cleaning. Do not use abrasive cleaners that may scratch or dull the surface.
- Carefully read the cleaner product label to ensure the cleaner is safe for use on the material.
- Always test your cleaning solution on an inconspicuous area before applying to the entire surface.
- Do not allow cleaners to sit or soak on the surface.
- Wipe surfaces clean and rinse completely with water immediately after cleaner application. Rinse and dry any overspray that lands on nearby surfaces.

## Care and Cleaning (cont.)

- Use a soft, dampened sponge or cloth. Never use an abrasive material such as a brush or scouring pad to clean surfaces.

For detailed cleaning information and products to consider, visit [www.kohler.com/clean](http://www.kohler.com/clean). To order Care & Cleaning information, call 1-800-456-4537.

## Warranty

### KOHLER® Faucet Lifetime Limited Warranty

Kohler Co. warrants its Faucets\* manufactured after January 1, 1997, to be leak and drip free during normal residential use for as long as the original consumer purchaser owns his or her home. If the Faucet should leak or drip during normal use, Kohler Co. will, free of charge, mail to the purchaser the cartridge necessary to put the Faucet in good working condition. This warranty applies only to Kohler Faucets installed in the United States of America, Canada or Mexico ("North America").

Kohler Co. also warrants all other aspects of the faucet or accessories ("Faucet")\*, (except gold, non-Vibrant®, non-chrome finishes) to be free of defects in material and workmanship during normal residential use for as long as the original consumer purchaser owns his or her home. This warranty applies only to Kohler Faucets installed in North America. If a defect is found in normal residential use, Kohler Co. will, at its election, repair, provide a replacement part or product, or make appropriate adjustment. Damage to a product caused by accident, misuse, or abuse is not covered by this warranty. Improper care and cleaning will void the warranty\*\*. Proof of purchase (original sales receipt) must be provided to Kohler Co. with all warranty claims. Kohler Co. is not responsible for labor charges, installation, or other incidental or consequential costs. In no event shall the liability of Kohler Co. exceed the purchase price of the Faucet.

If the Faucet is used commercially or is installed outside of North America, or if the finish is gold, non-Vibrant or a painted or powder coated color finish, Kohler Co. warrants the Faucet to be free from defects in material and workmanship for one (1) year from the date the product is installed, under Kohler Co.'s standard one-year limited warranty.

If you believe that you have a warranty claim, contact Kohler Co., either through your Dealer, Plumbing Contractor, Home Center or E-tailer, or by writing Kohler Co., Attn.: Customer Care Center, 444 Highland Drive, Kohler, WI 53044, USA. Please be sure to provide all pertinent information regarding your claim, including a complete description of the problem, the product, model number, color, finish,

## Warranty (cont.)

the date the product was purchased and from whom the product was purchased. Also include your original invoice. For other information, or to obtain the name and address of the service and repair facility nearest you, call 1-800-4-KOHLER (1-800-456-4537) from within the USA and Canada, and 001-800-456-4537 from within Mexico, or visit [www.kohler.com](http://www.kohler.com) within the USA, [www.ca.kohler.com](http://www.ca.kohler.com) from within Canada, or [www.mx.kohler.com](http://www.mx.kohler.com) in Mexico.

**KOHLER CO. AND/OR SELLER ARE PROVIDING THESE WARRANTIES IN LIEU OF ALL OTHER WARRANTIES, EXPRESSED OR IMPLIED, INCLUDING BUT NOT LIMITED TO THE IMPLIED WARRANTIES OF MERCHANTABILITY AND FITNESS FOR A PARTICULAR PURPOSE. KOHLER CO. AND/OR SELLER DISCLAIM ALL LIABILITY FOR SPECIAL, INCIDENTAL OR CONSEQUENTIAL DAMAGES. Some states/provinces do not allow limitations of how long an implied warranty lasts or the exclusion or limitation of such damages, so these limitations and exclusions may not apply to you. This warranty gives the consumer specific legal rights. You may also have other rights that vary from state/province to state/province.**

**This is Kohler Co.'s exclusive written warranty.**

\*Trend<sup>®</sup> faucets, MasterShower<sup>®</sup> tower, BodySpa systems and components; WaterHaven<sup>®</sup> tower, systems and components; Tripoint<sup>®</sup> faucets, Polished Gold, non-Vibrant and painted or powder coated finishes, fittings; all items within the "Fixture Related" section of the Kohler Faucets Price Book, drains, Duostrainer<sup>®</sup> sink strainers, soap/lotion dispensers, Moxie<sup>®</sup> Wireless Speaker; and faucets used in commercial settings, and outside North America, are covered by Kohler Co.'s one-year limited warranty.

\*\*Never use cleaners containing abrasive cleansers, ammonia, bleach, acids, waxes, alcohol, solvents or other products not recommended for chrome. This will void the warranty.

## Warranty

### For Mexico

KOHLER CO.

It is recommended that at the time of purchase, you verify that all accessories and components are complete in this package.

This Kohler product is warranted to be free of defects in material and workmanship for one (1) year from the date of purchase as shown on the invoice or receipt.

**Warranty (cont.)**

1. Kohler Co. will only service its commercialized products through its authorized distributors.
2. To obtain warranty service, please present the invoice and corresponding warranty.
3. Through its authorized distributors, Kohler Co. promises to repair the defective product or provide a new replacement or an equivalent model (in those cases that the model has been discontinued) when the product is beyond repair, without any charge to the consumer.
4. The time of repair will not exceed six (6) weeks commencing on the date the product is received.
5. It is recommended that the consumer save the invoice or receipt as additional protection, as it may substitute the warranty in the case that there is a discrepancy in the validity of the warranty.

**EXCEPTIONS AND RESTRICTIONS**

The Warranty will not be valid in the following cases:

1. When the product is not operated in accordance with the instructions concerning use and operation set forth in the owner's manual or installation instructions, and when the recommendations and warnings included are not observed.
2. When the product has been modified or dismantled partially or totally; or has been used in a negligent fashion and as a consequence has suffered damages attributable to the consumer, individual, or hardware not authorized by Kohler Co.
3. This warranty does not cover the damages as a result of disaster such as fire or acts of God, including flooding, earthquake, or electric storms, etc. To obtain a list of distributors in your area where you can exercise your rights under this warranty, please call 001-800-456-4537.

KOHLER CO., KOHLER, WI 53044 U.S.A.

**IMPORTER:**

COMERCIALIZADORA INTERCERAMIC, S.A. DE C.V.

AV. CARLOS PACHECO NO. 7200, COL. MADERA 65

CHIHUAHUA, CHIH., MEXICO C.P. 31060

R.F.C. CIN141022IE9

TEL: 52 (614) 429-11-11

**IMPORTER:**

**Warranty (cont.)**

GAMA MATERIALES Y ACEROS, S.A. DE C.V.  
AVE LOS ANGELES NO. 1800  
COL VALLE DEL NOGALAR, SAN NICOLAS DE LOS GARZA  
N.L. MEXICO  
R.F.C. GMA901220U11  
TEL: 81-1160-5500