



Manufactured by:
Backyard Discovery
3305 Airport Drive, Pittsburg, KS 66762
800-856-4445

Basepoint Business Centre: Rivermead Drive, Westlea, Swindon SN5 7EX Phone: 0800-118-2476
J.P. Coenstraat 7, The Bridge, The Hague, 2595 WP, Netherlands Phone: 08005678990

HENLEY 4-6 PERSON OUTDOOR CABIN SAUNA

MODEL # : 2504776, 2504776V

THE ASSEMBLY MANUAL MUST BE RETAINED SINCE IT CONTAINS IMPORTANT INFORMATION
ELECTRICIAN WORK IS REQUIRED TO INSTALL A DEDICATED 240V/50AMP CIRCUIT



WARNING

Cancer and Reproductive Harm
www.P65Warnings.ca.gov



Please visit www.backyarddiscovery.com

For the most up to date assembly manual, to register your product, or to order replacement parts *Para obtener instrucciones en español, visite*
www.backyarddiscovery.com



EASY STEP-BY-STEP
3D INTERACTIVE INSTRUCTIONS
DOWNLOAD THE FREE APP



OWNER'S MANUAL - BASIC SETUP DIMENSIONS & ASSEMBLY NOTES

CHOOSE A GOOD LOCATION FOR YOUR SAUNA!

It is critically important the sauna foundation is sturdy and level.

An unstable foundation can cause the sauna to tilt, shift, or fall, leading to injury.

Pay close attention to the items needed for each step. Make sure you are using the correct hardware for each step.

- Using incorrect hardware may result in improper assembly.
- Ensure the surface is firm and level and can support the weight of the sauna and its users. (1000+ lbs.)
- Many garages, basements or deck floors are sloped for drainage. A slight slope will not be an issue. A more pronounced slope will require shimming to make the sauna level.
- Consider a concrete slab, paver stones, or something similar to prevent the cradle supports from settling in the ground. Concrete anchors are provided in the kit.
- If installing on the ground or gravel surface, ground anchors are included in the kit.
- If installing on a deck, confirm there is ample structural support under the deck. The hardware to mount to a wood deck is NOT included and will need to be purchased separately.
- Consider distance from your electrical service box as this can greatly impact the cost of needed electrical work
- If located in an area that tends to receive high winds, it is recommended to take extra precautions to ensure the door does not blow open. In most situation, this should not be a concern.

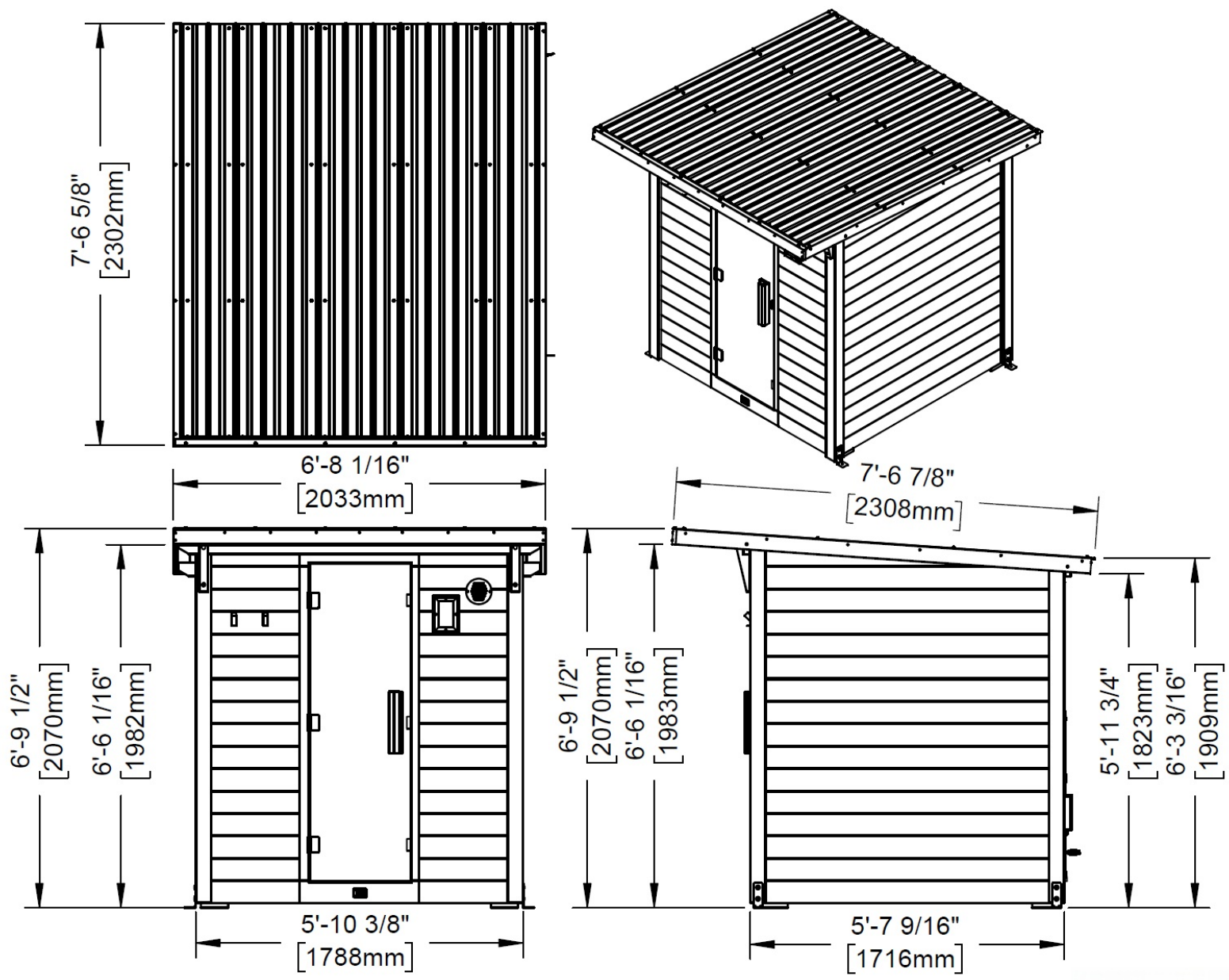

OWNER'S MANUAL - ANCHORING LAYOUT

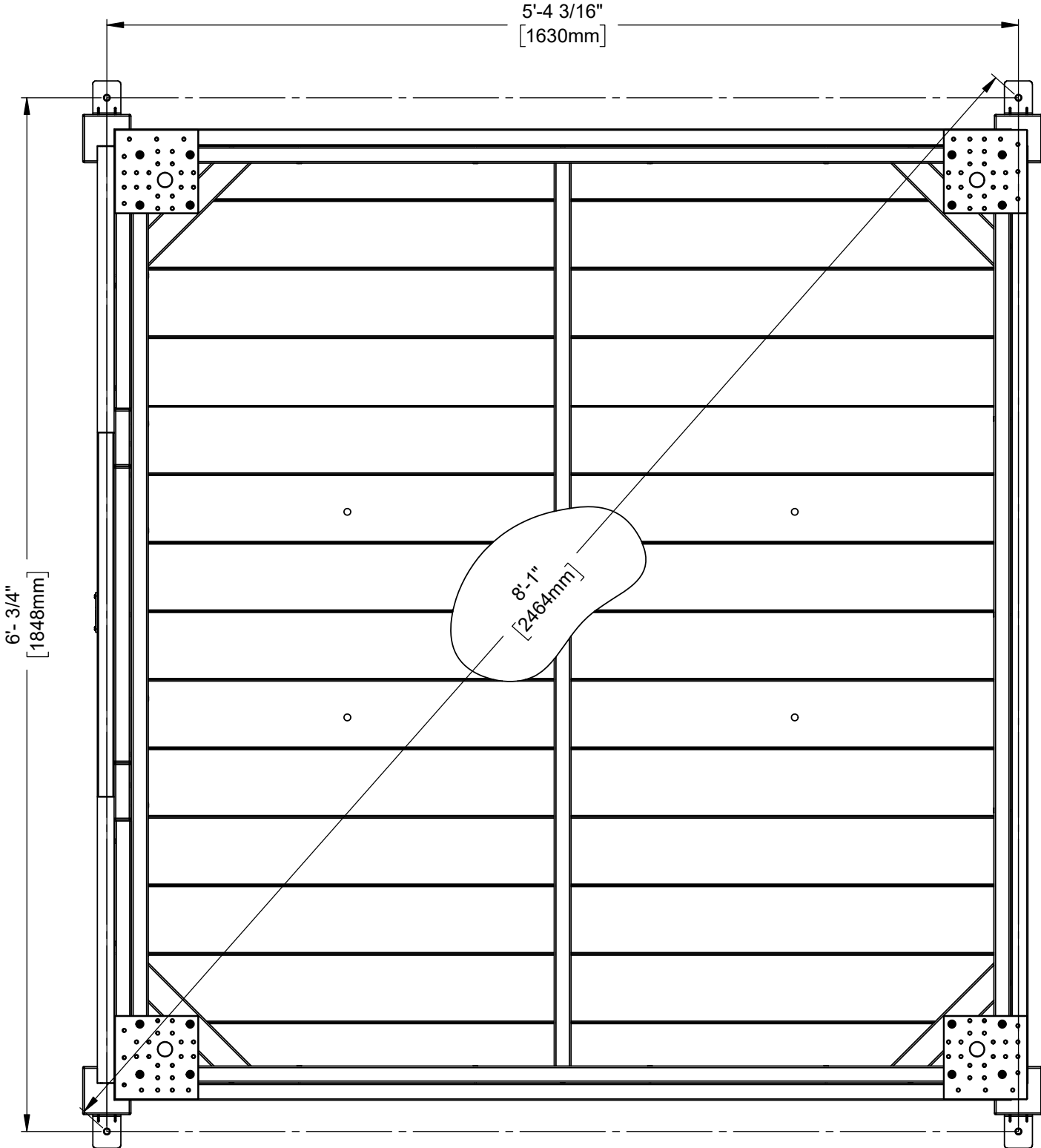

OWNER'S MANUAL - PARTS IDENTIFICATION

WOOD COMPONENTS (NOT TO SCALE)

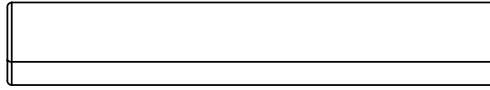

AM02 DOOR HANDLE-W4L22361
(x1) 2 1/4"x3"x13 5/16" (57x76x338)



E01 TRIM BOARD-W4L22459
(x2) 1 7/16"x3 3/8"x78 1/8" (36x86x1984)



H01 ROOF TRIM-W4L22360
(x2) 15/16"x3 3/8"x89 3/8" (24x86x2270)



HB01 WALL BOARD-W4L22456
(x2) 15/16"x2 3/4"x63 9/16" (24x70x1614)



NG01 SLAT-W4L21949
(x3) 13/16"x3 3/8"x65 3/4" (20x86x1670)



NG04 FASCIA-W4L22458
(x1) 13/16"x3 1/8"x78 1/8" (20x80x1984)



NR01 HEATER GUARD BOARD-W4L22493
(x5) 13/16"x2 3/8"x20 1/2" (20x60x521)



NR04 HEATER GUARD BOARD-W4L22037
(x5) 13/16"x2 3/8"x15 11/16" (20x60x398)



OG01 FLOOR JOIST-W4L22461
(x2) 1 3/16"x3 3/8"x17 1/4" (30x86x438)



OG02 SEAT CLEAT-W4L21943
(x1) 1 3/16"x3 3/8"x60 15/16" (30x86x1548)



OG03 FLOOR JOIST-W4L22462
(x1) 1 3/16"x3 3/8"x63 9/16" (30x86x1614)

OWNER'S MANUAL - PARTS IDENTIFICATION

WOOD COMPONENTS (NOT TO SCALE)



OG04 FLOOR JOIST-W4L22463
(x1) 1 3/16"x3 3/8"x63 9/16" (30x86x1614)



OG05 FLOOR JOIST-W4L22464
(x1) 1 3/16"x3 3/8"x63 9/16" (30x86x1614)



OG06 ROOF BOARD-W4L22469
(x1) 1 3/16"x3 1/8"x88 9/16" (30x79x2250)

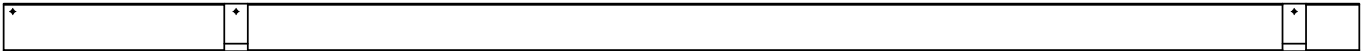

OG07 ROOF BOARD-W4L22470
(x1) 1 3/16"x3 1/8"x88 9/16" (30x79x2250)



OG08 SEAT CLEAT-W4L22384
(x2) 1 3/16"x3 3/8"x19 1/8" (30x86x486)



OG09 FLOOR JOIST-W4L22485
(x2) 1 3/16"x3 3/8"x63 1/16" (30x86x1602)



OG10 WIREWAY BOARD-W4L22387
(x1) 1 3/16"x3 3/8"x60 3/4" (30x86x1543)



OG11 WIREWAY BOARD-W4L22733
(x1) 1 3/16"x2 1/4"x3 3/8" (30x57x86)



OG12 WIREWAY BOARD-W4L22389
(x1) 1 3/16"x3 3/8"x19 3/4" (30x86x501)



OG13 LIGHT MOUNT-W4L22494
(x1) 30x3 3/8"x40 9/16" (30x86x1030)

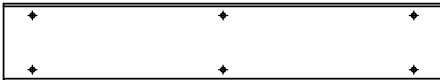

OG15 SEAT CLEAT-W4L22407
(x2) 1 3/16"x3 3/8"x19 1/8" (30x86x486)



OG16 SEAT CLEAT-W4L22585
(x1) 1 3/16"x3 3/8"x18 1/4" (30x86x464)



OJ01 WALL BOARD-W4L22347
(x2) 1 3/16"x5 1/4"x63 1/16" (30x134x1602)

OWNER'S MANUAL - PARTS IDENTIFICATION

WOOD COMPONENTS (NOT TO SCALE)

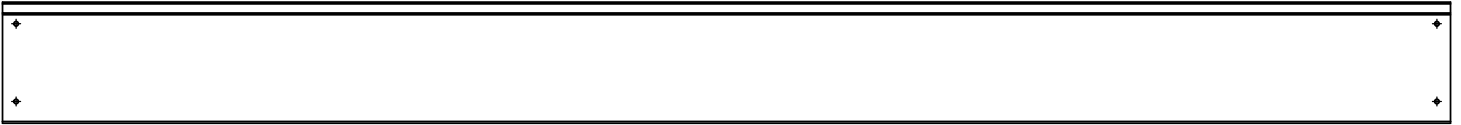

OJ02 WALL BOARD-W4L22348
(x28) 1 3/16"x5 1/4"x63 1/16" (30x134x1602)

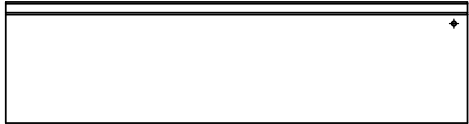

OJ03 WALL BOARD-W4L22471
(x1) 1 3/16"x5 1/4"x20 1/8" (30x134x511)

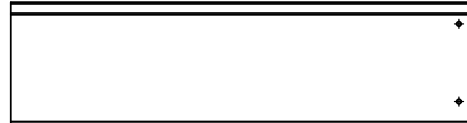

OJ04 WALL BOARD-W4L22472
(x10) 1 3/16"x5 1/4"x20 1/8" (30x134x511)



OJ05 WALL BOARD-W4L22473
(x1) 1 3/16"x5 1/4"x20 1/8" (30x134x511)

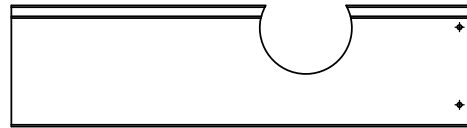

OJ06 WALL BOARD-W4L22474
(x1) 1 3/16"x5 1/4"x20 1/8" (30x134x511)



OJ07 WALL BOARD-W4L22475
(x1) 1 3/16"x5 1/4"x20 1/8" (30x134x511)

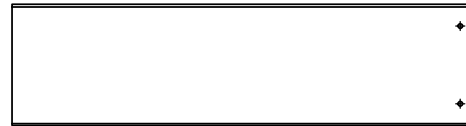

OJ08 WALL BOARD-W4L22476
(x1) 1 3/16"x5 1/4"x20 1/8" (30x134x511)

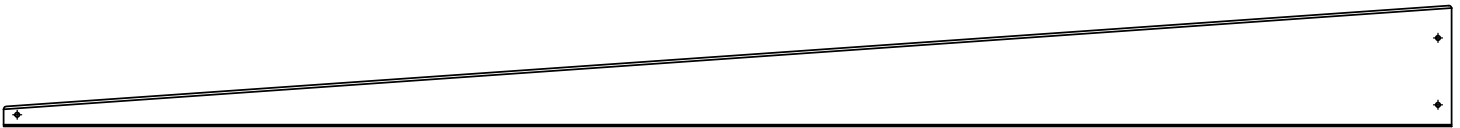

OJ09 WALL BOARD-W4L22357
(x2) 1 3/16"x5 1/4"x63 1/16" (30x134x1602)



OJ10 ROOF BOARD-W4L22359
(x15) 1 3/16"x5 1/4"x88 9/16" (30x134x2250)



OJ11 WALL BOARD-W4L22477
(x1) 1 3/16"x5 1/4"x20 1/8" (30x134x511)



OJ12 WALL BOARD-W4L22478
(x14) 1 3/16"x5 1/4"x20 1/8" (30x134x511)

OWNER'S MANUAL - PARTS IDENTIFICATION

WOOD COMPONENTS (NOT TO SCALE)

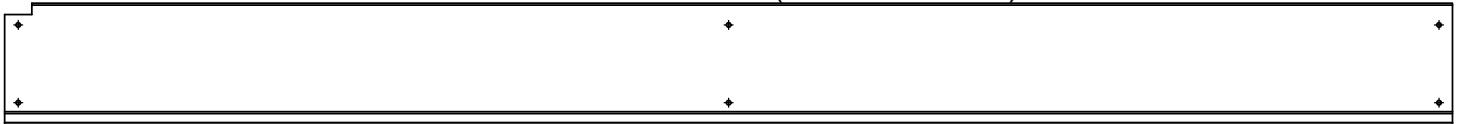

OJ13 FLOOR BOARD-W4L22479
(x1) 1 3/16"x5 1/4"x63 1/16" (30x134x1602)

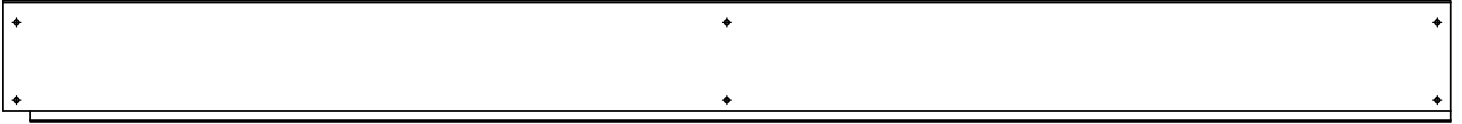

OJ14 FLOOR BOARD-W4L22480
(x1) 1 3/16"x5 1/4"x63 1/16" (30x134x1602)

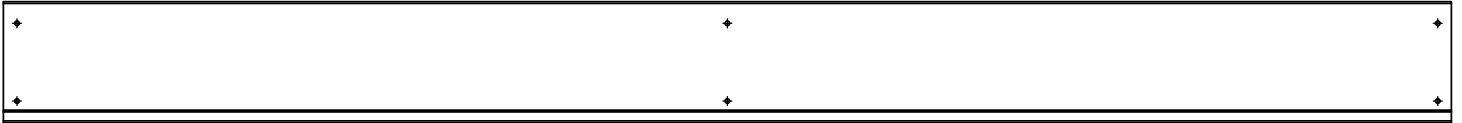

OJ15 FLOOR BOARD-W4L22481
(x4) 1 3/16"x5 1/4"x63 1/16" (30x134x1602)



OJ16 WALL BOARD-W4L22482
(x1) 1 3/16"x5 1/4"x20 1/8" (30x134x511)

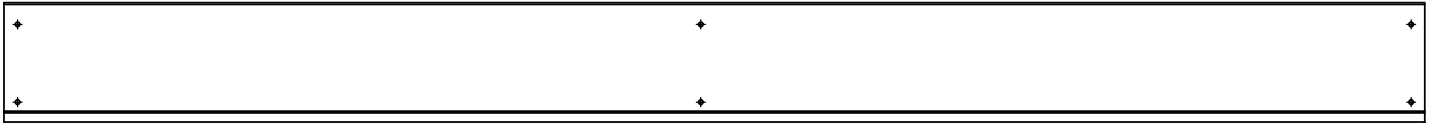

OJ17 FLOOR BOARD-W4L22483
(x4) 1 3/16"x5 1/4"x61 7/8" (30x134x1572)

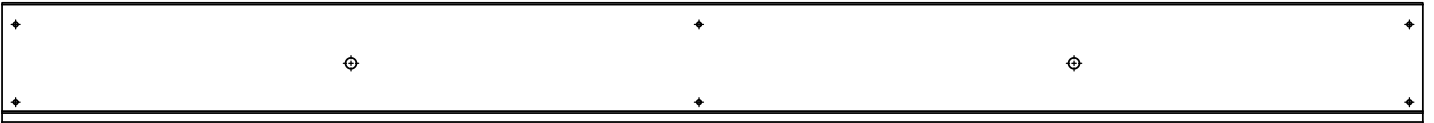

OJ18 FLOOR BOARD-W4L22484
(x2) 1 3/16"x5 1/4"x61 7/8" (30x134x1572)

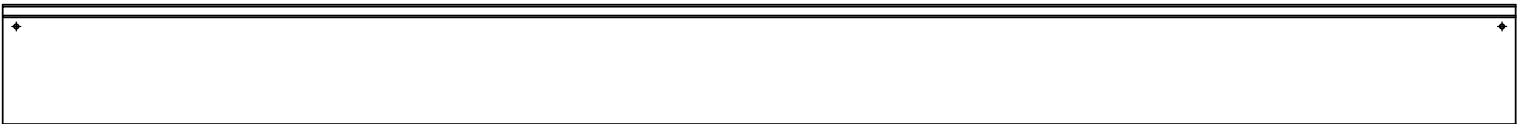

OJ19 WALL BOARD-W4L22486
(x1) 1 3/16"x5 1/4"x65 7/8" (30x134x1674)

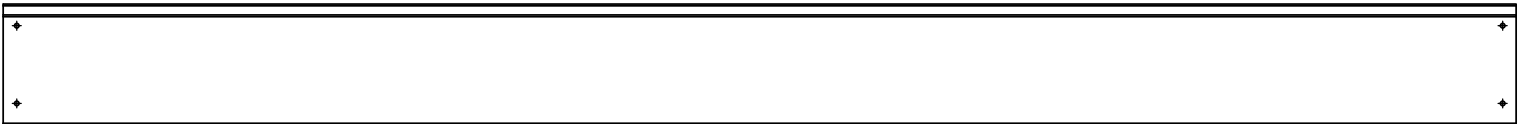

OJ20 WALL BOARD-W4L22487
(x10) 1 3/16"x5 5/16"x65 7/8" (30x134x1674)

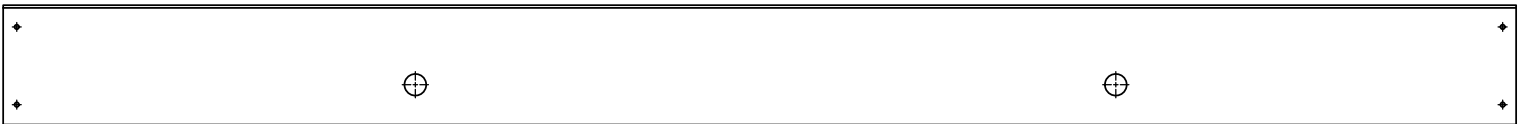

OJ21 WALL BOARD-W4L22488
(x1) 1 3/16"x5 1/4"x65 7/8" (30x134x1674)



OJ22 WALL BOARD-W4L22489
(x1) 1 3/16"x5 1/4"x65 7/8" (30x134x1674)

OWNER'S MANUAL - PARTS IDENTIFICATION

WOOD COMPONENTS (NOT TO SCALE)

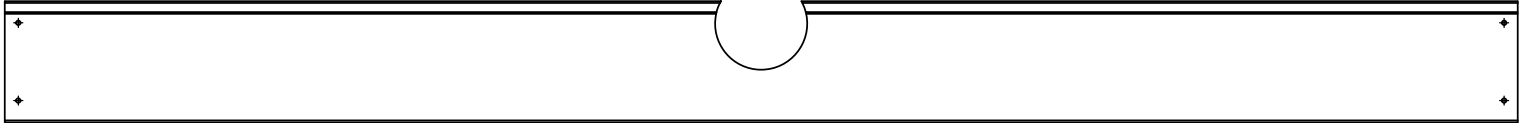

OJ24 WALL BOARD-W4L22491
(x1) 1 3/16"x5 1/4"x65 7/8" (30x134x1674)

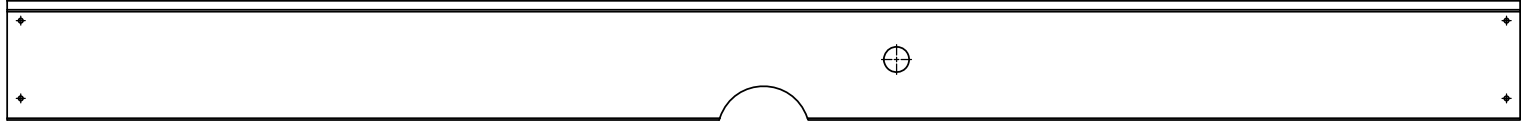

OJ25 WALL BOARD-W4L22492
(x1) 1 3/16"x5 1/4"x65 7/8" (30x134x1674)



OO01 SLAT CLEAT-W4L22404
(x2) 1 3/16"x1 3/16"x14" (30x30x355)



OO02 FLOOR TRIM-W4L22365
(x2) 1 3/16"x1 3/16"x63 1/16" (30x30x1602)

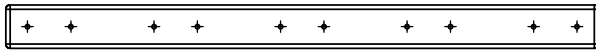

OO03 HEATER GUARD BOARD-W4L22038
(x2) 1 3/16"x1 3/16"x16 1/8" (30x30x410)



OO04 HEATER GUARD BOARD-W4L22035
(x1) 1 3/16"x1 3/16"x16 1/8" (30x30x410)

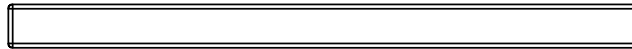

OO06 FLOOR TRIM-W4L22465
(x2) 1 3/16"x1 3/16"x17 1/4" (30x30x438)

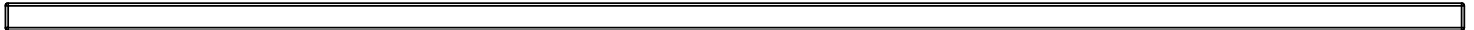

OO07 FLOOR TRIM-W4L22466
(x1) 1 3/16"x1 3/16"x63 9/16" (30x30x1614)



OO08 TRIM-W4L22495
(x1) 1 3/16"x1 3/16"x18 7/16" (30x30x469)



OO09 TRIM-W4L22496
(x2) 1 3/16"x1 3/16"x12 5/8" (30x30x321)



OO13 TRIM-W4L22414
(x2) 1 3/16"x1 3/16"x61" (30x30x1549)

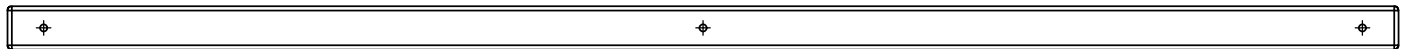

OO14 TRIM-W4L22607
(x2) 1 3/16"x1 3/16"x37 7/8" (30x30x962)

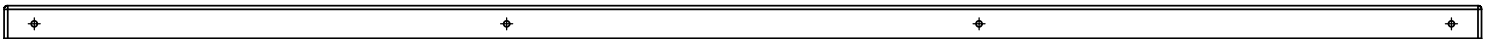

OO15 TRIM-W4L22730
(x1) 1 3/16"x1 3/16"x48 1/4" (30x30x1226)

OWNER'S MANUAL - PARTS IDENTIFICATION

WOOD COMPONENTS (NOT TO SCALE)



OO16 TRIM-W4L22415
(x1) 1 3/16"x1 3/16"x2 3/8" (30x30x60)



OO17 TRIM-W4L22732
(x1) 1 3/16"x1 3/16"x57 1/16" (30x30x1449)



OO18 TRIM-W4L22731
(x1) 1 3/16"x1 3/16"x49 13/16" (30x30x1266)



OR01 SEAT UPRIGHT-W4L22406
(x2) 1 3/16"x2 3/8"x28 3/4" (30x60x730)



OR02 ANGLE BRACE-W4L21946
(x4) 1 3/16"x2 3/8"x10 7/8" (30x60x276)



OR03 BENCH UPRIGHT-W4L22405
(x2) 1 3/16"x2 3/8"x14" (30x60x355)

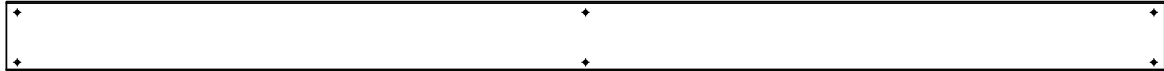

OS01 FLOOR BOARD-W4L22729
(x1) 1 3/16"x3 3/4"x63 1/16" (30x96x1602)



OV02 FLOOR BOARD-W4L22468
(x1) 1 3/16"x4 1/4"x63 1/16" (30x107x1602)

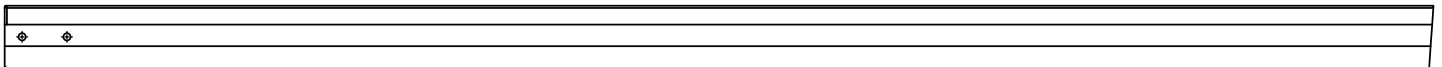

SP01 POST-W4L22341
(x1) 3 3/8"x3 3/8"x77 13/16" (86x86x1976)

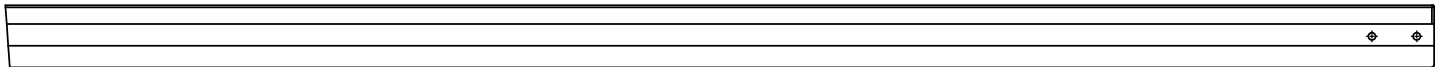

SP02 POST-W4L22342
(x1) 3 3/8"x3 3/8"x77 13/16" (86x86x1976)

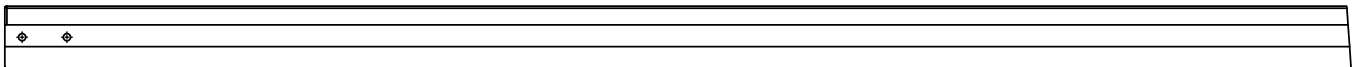

SP03 POST-W4L22343
(x1) 3 3/8"x3 3/8"x73 5/16" (86x86x1862)

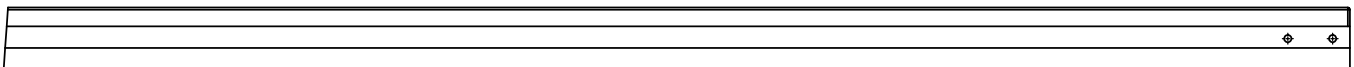

SP04 POST-W4L22344
(x1) 3 3/8"x3 3/8"x73 5/16" (86x86x1862)

OWNER'S MANUAL - PARTS IDENTIFICATION

WOOD COMPONENTS (NOT TO SCALE)

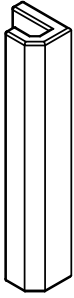

AM01 DOOR HANDLE-W2A04917
(x1) 2 1/4"x3"x13 5/16" (57x76x338)

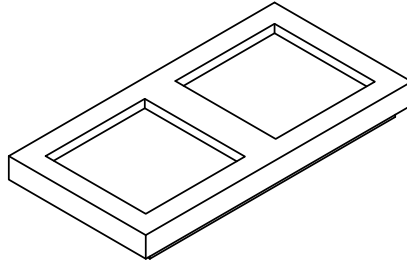

T01 THERMOMETER-W4L21965
(x1)

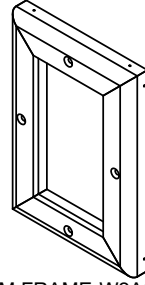

TF01 TRIM FRAME-W2A04797
(x1) 7/8"x5 9/16"x8 1/16" (22x142x204)



W01 SEAT TRIM-W4L21948
(x1) 1 9/16"x3 3/8"x65 3/4" (40x86x1670)



W02 FOOT BRACE-W4L22399
(x4) 1 15/16"x3 3/8"x10 1/4" (50x86x261)

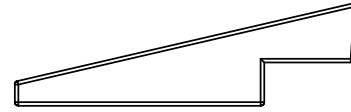

W03 ANGLE BRACE-W4L22409
(x2) 1 15/16"x3 3/8"x11 1/4" (50x86x285)



W04 SEAT TRIM-W4L22586
(x1) 1 9/16"x3 3/8"x65 3/4" (40x86x1670)



W05 SEAT TRIM-W4L22587
(x1) 1 9/16"x3 3/8"x22 1/16" (40x86x560)



W06 FASCIA-W4L22457
(x1) 1 15/16"x3 3/8"x80" (50x86x2032)

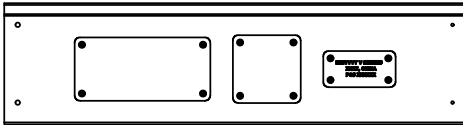

WB01 WALL BOARD ASSEMBLY-W2A05157
(x1) 1 3/16"x5 1/4"x20 1/8" (30x134x511)

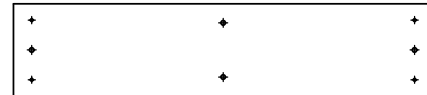

Y01 HEATER SPACER BOARD-W4L22601
(x2) 5/8"x4"x18 1/4" (16x102x464)

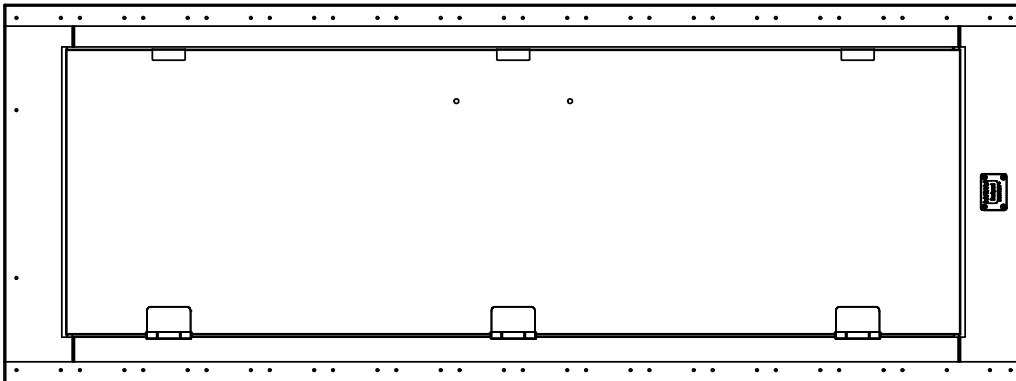

WP01 WALL PANEL ASSEMBLY-W2A04926
(x1) 2 3/8"x28 7/8"x77 5/8" (60x734x1972)

OWNER'S MANUAL - PARTS IDENTIFICATION

WOOD COMPONENTS (NOT TO SCALE)

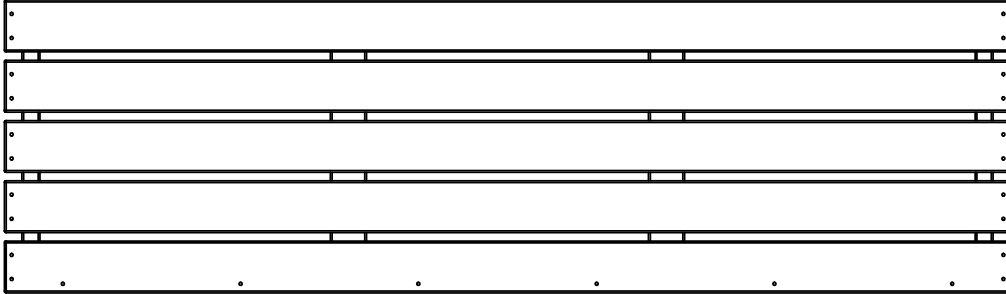

BA01 BENCH ASSEMBLY-W2A04927
(x1) 1 15/16"x19 1/8"x65 3/4" (50x486x1670)



BA02 BENCH ASSEMBLY-W2A04928
(x1) 1 15/16"x19 1/8"x65 3/4" (50x486x1670)



BA03 BENCH ASSEMBLY-W2A04983
(x1) 1 15/16"x19 1/8"x24 13/16" (50x486x630)

OWNER'S MANUAL - PARTS IDENTIFICATION

ACCESSORY COMPONENTS (NOT TO SCALE)

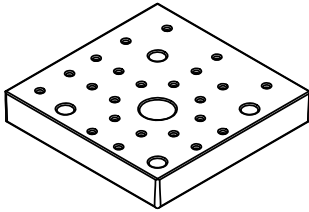

1526 BASE FOOT-A6P01526
(x4) 1"x5 7/8"x5 7/8" (25x150x150)

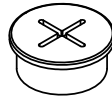

1467 25mm SILICONE GROMMET-A6P01467
(x4)

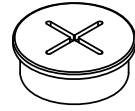

1468 30mm SILICONE GROMMET-A6P01468
(x1)

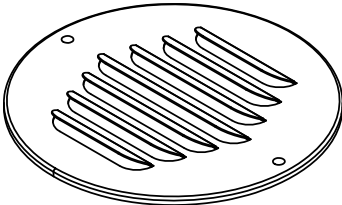

5285 VENT-A4M05285
(x2)

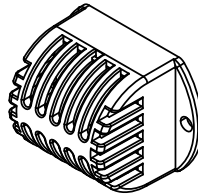

5590-08 TEMPERATURE SENSOR-A4M05590-08
(x1)

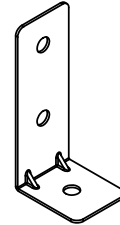

5917 ANCHOR BRACKET-A4M05917
(x4) 1/16"x1 15/16"x7 5/8" (2x50x193)

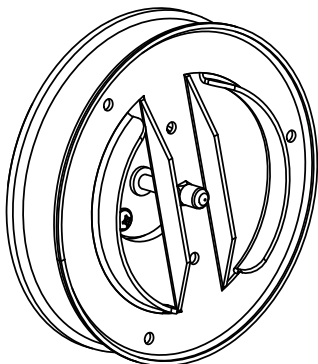

5592 VENT ASSEMBLY-A4M05592
(x1)

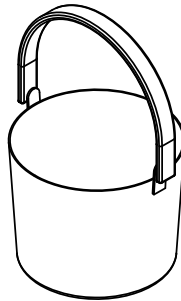

B01 BUCKET-A4M05673
(x1)

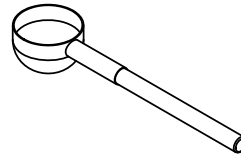

L01 LADLE-A4M05596
(x1)

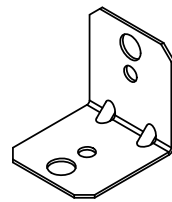

555 L BRACKET BLK-A4M00555
(x9) 1 1/4"x1 3/8"x1 3/8" (32x35x35)

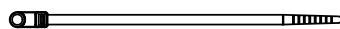

ZIP CABLE TIE-A6P01448
(x10)

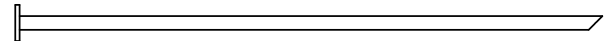

5667 GROUND STAKE-A4M05667
(x4) 1"16" (25xx406)

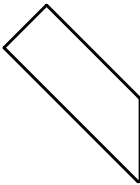

5672 GARMENT HANGER ASSEMBLY-A4M05672
(x2)

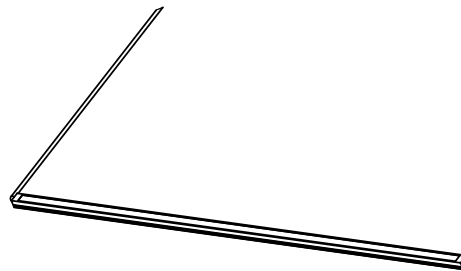

1493-02 LED LIGHT-A6P01493-02
(x2)

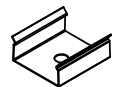

LIGHT CLIP-A6P01493-04
(x4)

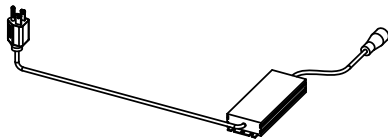

1493-03 LED POWER SUPPLY-A6P01493-03
(x1) (xx)

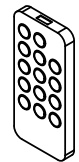

REMOTE-A6P01493-05
(x1)

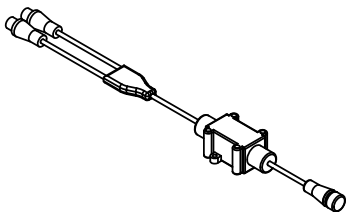

1493-06 REMOTE MODULE-A6P01493-06
(x1)

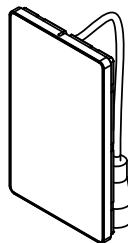

5590-02 CONTROL PANEL-A4M05590-02
(x1)

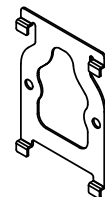

5590-03 CONTROL PANEL MOUNTING BRACKET-A4M05590-03
(x1)

OWNER'S MANUAL - PARTS IDENTIFICATION

ACCESSORY COMPONENTS (NOT TO SCALE)

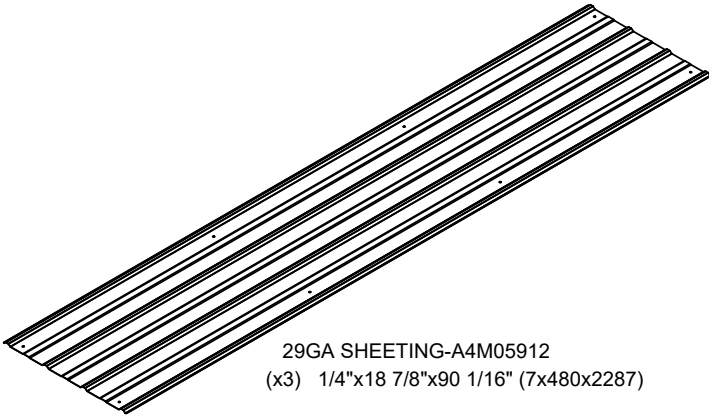

29GA SHEETING-A4M05912
(x3) 1/4"x18 7/8"x90 1/16" (7x480x2287)

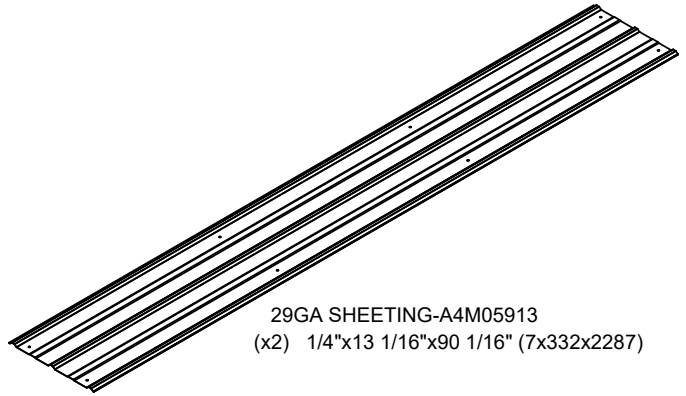

29GA SHEETING-A4M05913
(x2) 1/4"x13 1/16"x90 1/16" (7x332x2287)

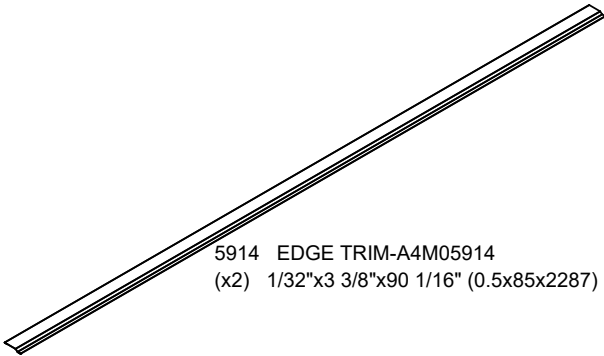

5914 EDGE TRIM-A4M05914
(x2) 1/32"x3 3/8"x90 1/16" (0.5x85x2287)

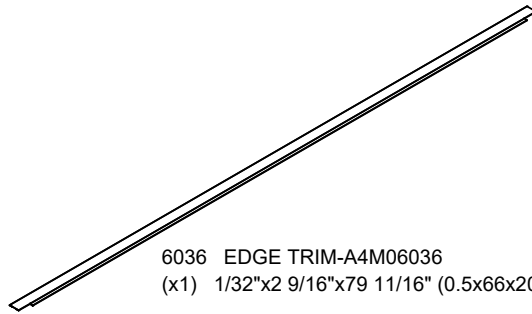

6036 EDGE TRIM-A4M06036
(x1) 1/32"x2 9/16"x79 11/16" (0.5x66x2024)

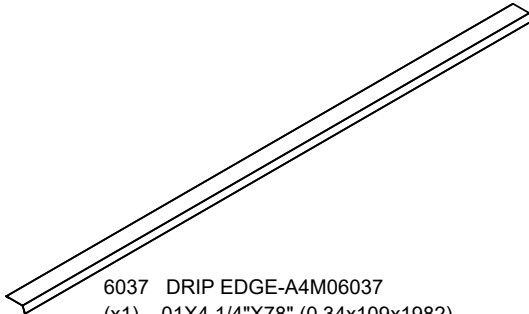

6037 DRIP EDGE-A4M06037
(x1) .01X4 1/4"X78" (0.34x109x1982)



1543 SAUNA POWER WIRE - A6P01543
(x1)



5590-10 WIRING HARNESS - A4M05590-10
(x1)

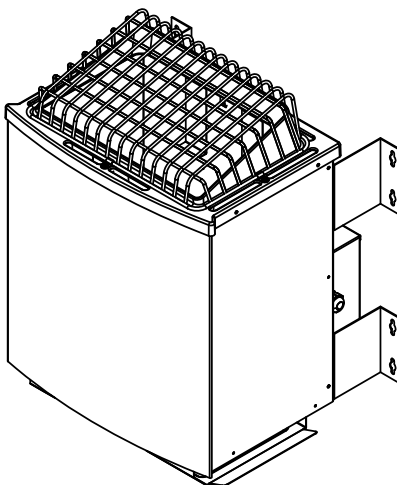

0253 9KW ELECTRIC SAUNA HEATER-9250253
(x1)

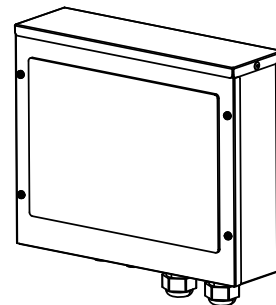

5590-01 SERVICE PANEL-A4M05590-01
(x1)

OWNER'S MANUAL - PARTS IDENTIFICATION

HARDWARE COMPONENTS

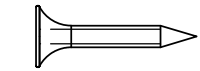

H101423 SCREW TFH 8X7/8 SS-BLK
(x4) 8x7/8

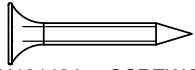

H101424 SCREW TFH 8X1 SS-BLK
(x4) 8x1

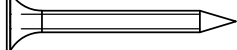

H101426 SCREW TFH 8X1 1/4 SS-BLK
(x16) 8x1-1/4

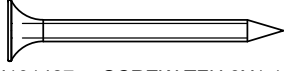

H101427 SCREW TFH 8X1 1/2 SS-BLK
(x8) 8x1-1/2

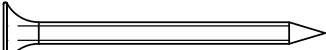

H101428 SCREW TFH 8X1 3/4 SS-BLK
(x137) 8x1-3/4

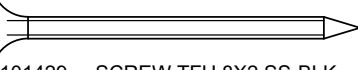

H101429 SCREW TFH 8X2 SS-BLK
(x744) 8x2

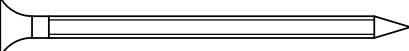

H101430 SCREW TFH 8X2 1/4 SS-BLK
(x26) 8x2-1/4

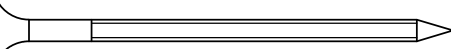

H101431 SCREW TFH 8X2 1/2 SS-BLK
(x14) 8x2-1/2

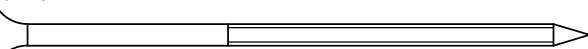

H101434 SCREW TFH 8X3 1/4 SS-BLK
(x12) 8x3 1/4



H101435 SCREW TFH 8X3 1/2 SS-BLK
(x2) 8x3 1/2

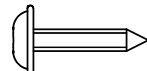

H101437 SCREW TWH 8x5/8 SS-BLK
(x4) 8x5/8



H101438 SCREW TWH 8x3/4 SS-BLK
(x22) 8x3/4



H101440 SCREW TWH 8x1 SS-BLK
(x11) 8x1

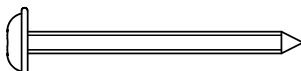

H101443 SCREW TWH 8x1 1/2 SS-BLK
(x16) 8x1-1/2

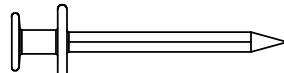

H101468 SCREW RAISED HEAD 8X1 BLK
(x8)

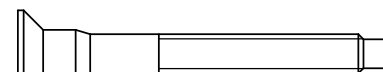

H101030 SCREW CONFIRMAT BLK
(x4) 7x2

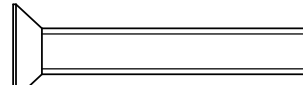

H101402 SCREW TFH 1/4-20 X 1 5/8 SS
(x2)

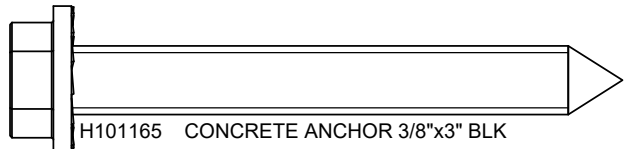

H101165 CONCRETE ANCHOR 3/8"x3" BLK
(x4) 3/8x3

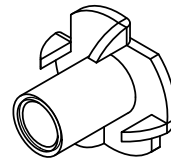

H100379 T-NUT BLK
(x8) 5/16



H101409 SCREW PPH 4x1/2 BLK
(x10) 4x1/2

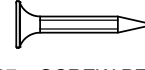

H100627 SCREW PFH BLK
(x2) 6x3/4

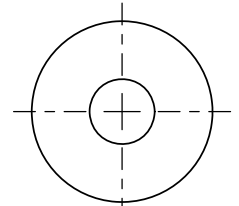

1403 POLY WASHER-H101403
(x4)

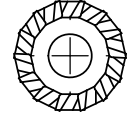

H100405 WASHER LOCK EXT BLK
(x12) 6x15

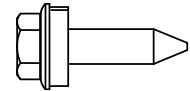

H101117 SCREW WOODGRIP
(x40) 10x3/4

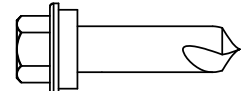

H101116 SCREW SELF TAPPING 1/4x1 BLK
(x16) 1/4 x 1

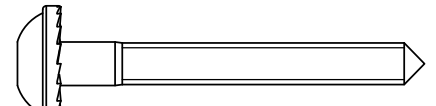

H100487 LAG SCREW WH BLK
(x12) 1/4x2

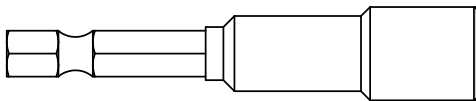

H101106 HEX DRIVER
(x1) 5/16

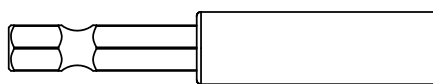

H101100 MAGNETIC DRIVER
(x1)

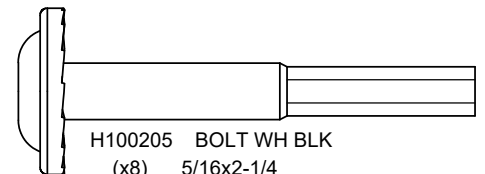

H100205 BOLT WH BLK
(x8) 5/16x2-1/4

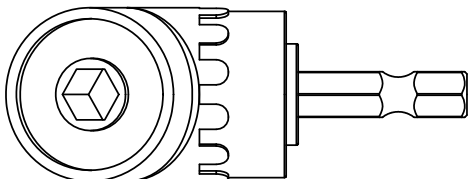

H101114 RIGHT ANGLE DRILL ADAPTER
(x1)

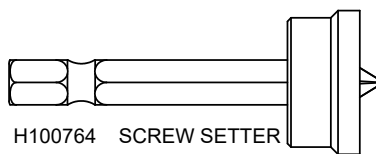

H100764 SCREW SETTER
(x1)

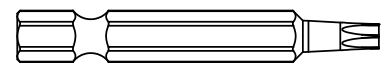

H100879 TORX BIT
(x1) T-20

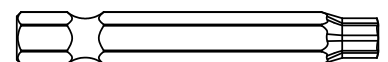

H100147 TORX BIT
(x1) T-30

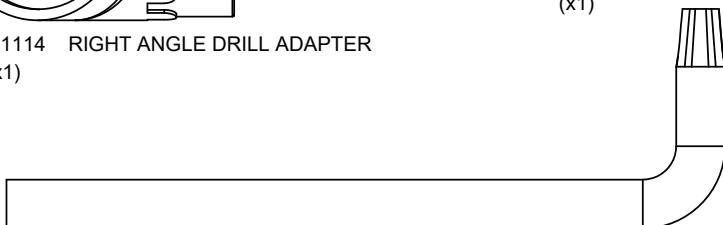

H100114 TORX WRENCH
(x1)

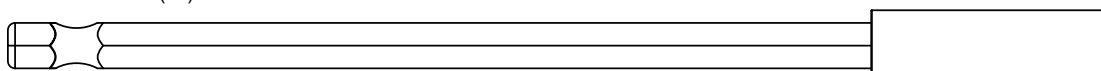

H101278 6" MAGNETIC DRIVER EXTENSION
(x1)

PRE-ASSEMBLY STEP 1 - SORTING PARTS

It is critical for ease of assembly that you take the time to sort and organize the wood and hardware.

WOOD PARTS:

- Organize wood parts by the three-digit, alpha-numeric number stamped on each board (ex. P01).
- If there are multiple boards with the same stamped number, stack those pieces together.
- Stamps can be found on the flat surface of the boards or on the end of the boards.
- Allow yourself plenty of room - the wood pieces can take up a significant amount of space.

NOTE: CARTONS ARE NOT ORGANIZED BY BOARD NUMBER.



HARDWARE PARTS:

- We recommend that you have a separate table to organize the hardware.
- Hardware bags are printed with a seven-digit, alpha-numeric part number.
- You can organize your hardware by part number or group by hardware type (i.e. bolts, nuts, etc.).
- During assembly you only need to reference the last four digits of the number.

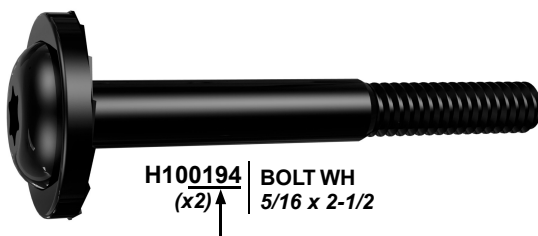

PRE-ASSEMBLY STEP 2 - TOOLS REQUIRED



Cordless Drill or Electric Drill



Drill Attachments:
Phillips Head

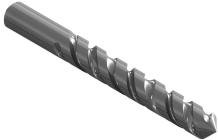

1/8", 3/16", 3/8" &
7/16" Drill Bits



Phillips Screw Driver

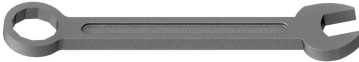

Open End
Wrenches
11/16"



3/8" Drive Ratchet, 1/2" &
7/16" STD Sockets, 1/2" &
7/16" Deep Sockets

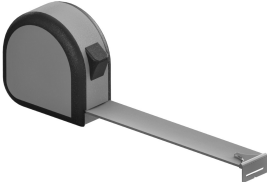

Tape Measure



Claw Hammer

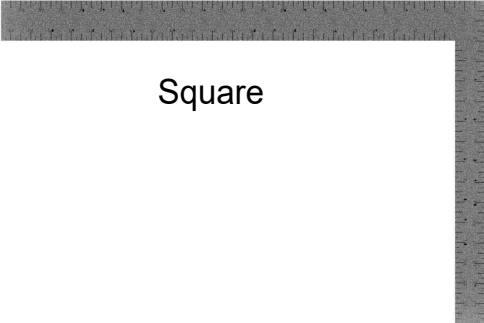

Square

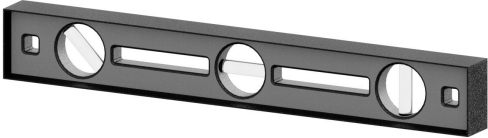

Level 24"



Rubber Mallet -
Optional

PRE-ASSEMBLY STEP 3 - CHOOSE YOUR ASSEMBLY METHOD

There are several types of assembly instructions available to you.

1. Printed Assembly Manual included with your set
2. BILT APP - 3D interactive instructions
3. Combination of the Printed Manual and BILT APP (Note: Step numbers can differ between the two methods)



The graphic is a promotional banner for the BILT app. It features the BILT logo on the left, which consists of a stylized hexagonal icon with a dot inside, followed by the word "BILT." in a bold, sans-serif font. To the right of the logo is a large QR code. Above the QR code, the text "SCAN FOR BILT. 3D INSTRUCTIONS" is written in a smaller font. Below the QR code, it says "POWERED BY BILT INTELLIGENT INSTRUCTIONS®". Underneath this, there are two buttons: "Download on the App Store" with the Apple logo and "GET IT ON Google Play" with the Google Play logo. In the center, the text "Scan for easy 3D instructions" is prominently displayed in a large, bold font, with "Download the BILT app before you begin" written below it in a smaller font. At the bottom of the graphic is a smartphone screen showing a 3D interactive assembly instruction. The screen displays a 3D model of a structure with a horizontal beam and a triangular support. A red arrow points to a specific part of the structure. The screen also shows a "Partners Needed" button in the top left, a close button (X) in the top right, and a play button in the bottom right. The number "17" is visible in the bottom left corner of the screen.

STEP 1 - FLOOR ASSEMBLY

QTY	PART NUMBER	DESCRIPTION
8	H101429	SCREW TFH 8X2 SS-BLK
4	H101430	SCREW TFH 8X2 1/4 SS-BLK



OG03 FLOOR JOIST - W4L22462
(x1) 1 3/16"x3 3/8"x63 9/16" (30x86x1614)



W02 FOOT BRACE - W4L22399
(x2) 1 15/16"x3 3/8"x10 1/4" (50x86x261)



OG09 FLOOR JOIST - W4L22485
(x2) 1 3/16"x3 3/8"x63 1/16" (30x86x1602)

- ALIGN PILOT HOLES.
- HAND TIGHTEN ONLY.

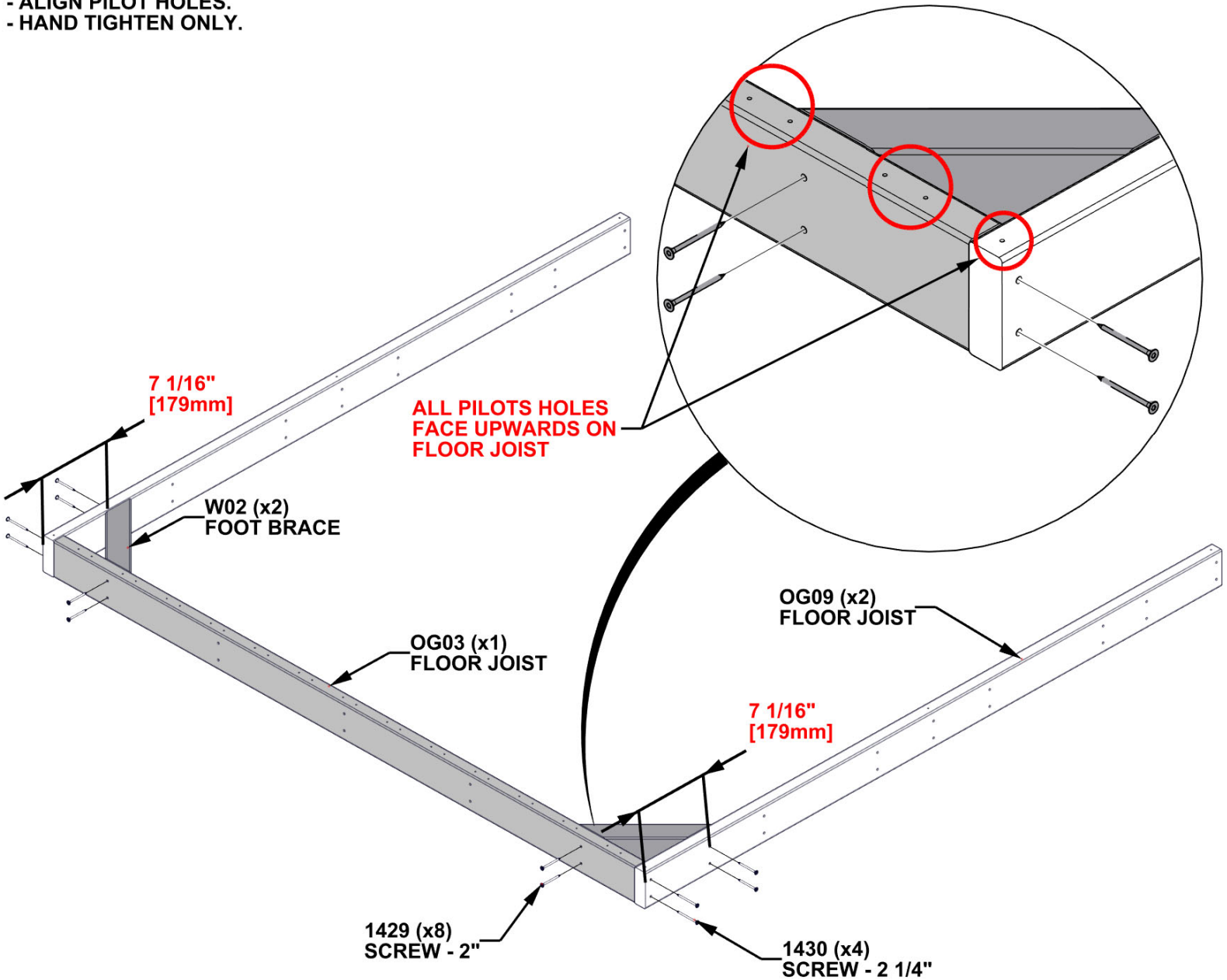

STEP 2 - FLOOR ASSEMBLY

QTY	PART NUMBER	DESCRIPTION
4	H101430	SCREW TFH 8X2 1/4 SS-BLK



OG05 FLOOR JOIST - W4L22464
(x1) 1 3/16"x3 3/8"x63 9/16" (30x86x1614)

- ALIGN PILOT HOLES.

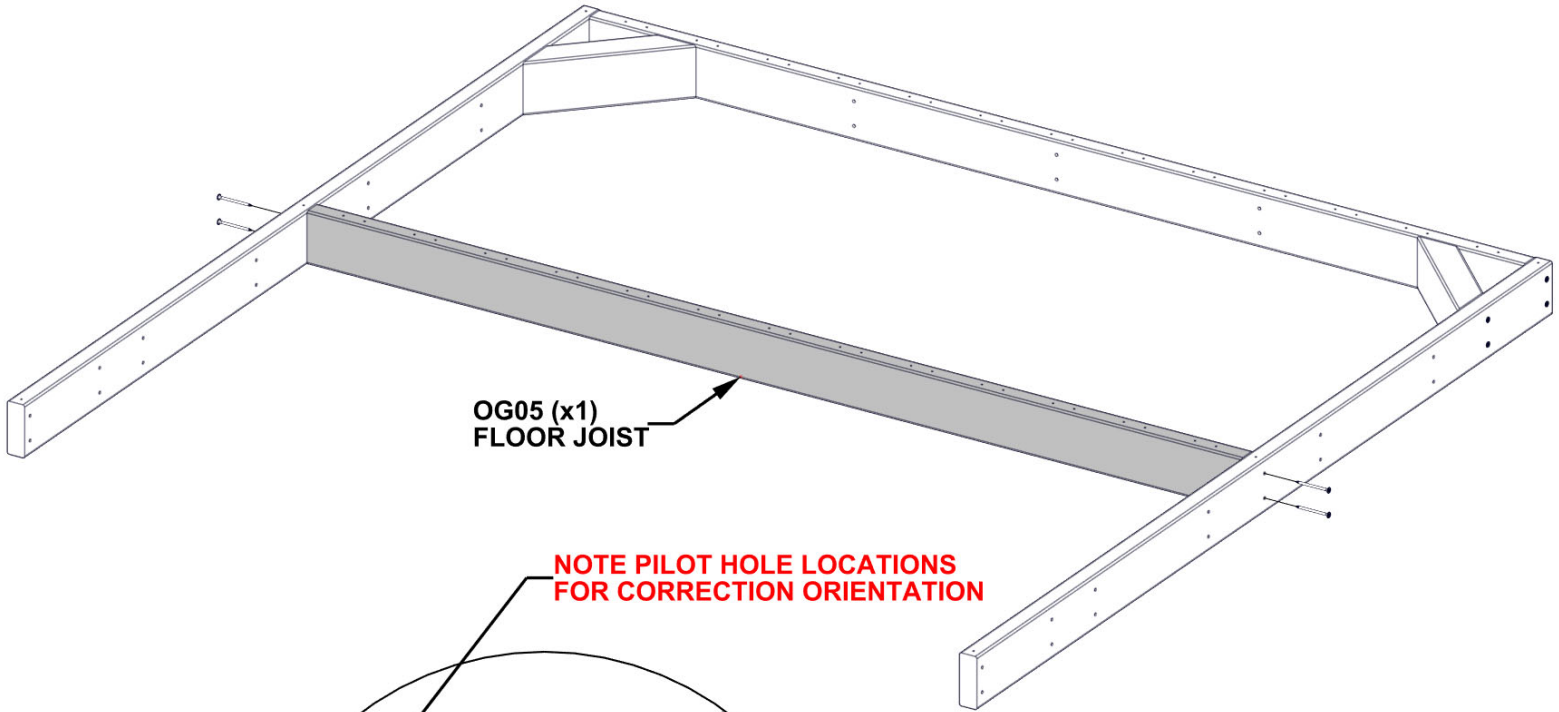

OG05 (x1)
FLOOR JOIST

**NOTE PILOT HOLE LOCATIONS
FOR CORRECTION ORIENTATION**

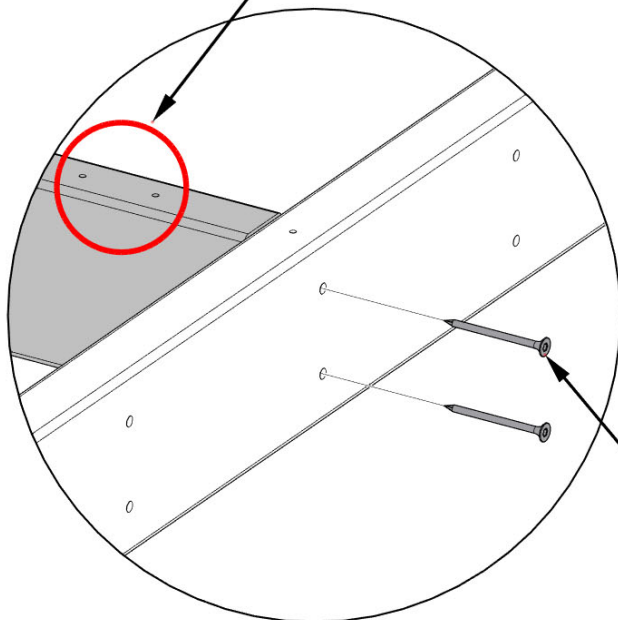

1430 (x4)
SCREW - 2 1/4"

STEP 3 - FLOOR ASSEMBLY

QTY	PART NUMBER	DESCRIPTION
4	H101429	SCREW TFH 8X2 SS-BLK



OG04 FLOOR JOIST - W4L22463
(x1) 1 3/16"x3 3/8"x63 9/16" (30x86x1614)



W02 FOOT BRACE - W4L22399
(x2) 1 15/16"x3 3/8"x10 1/4" (50x86x261)

- ALIGN PILOT HOLES.
- HAND TIGHTEN ONLY.

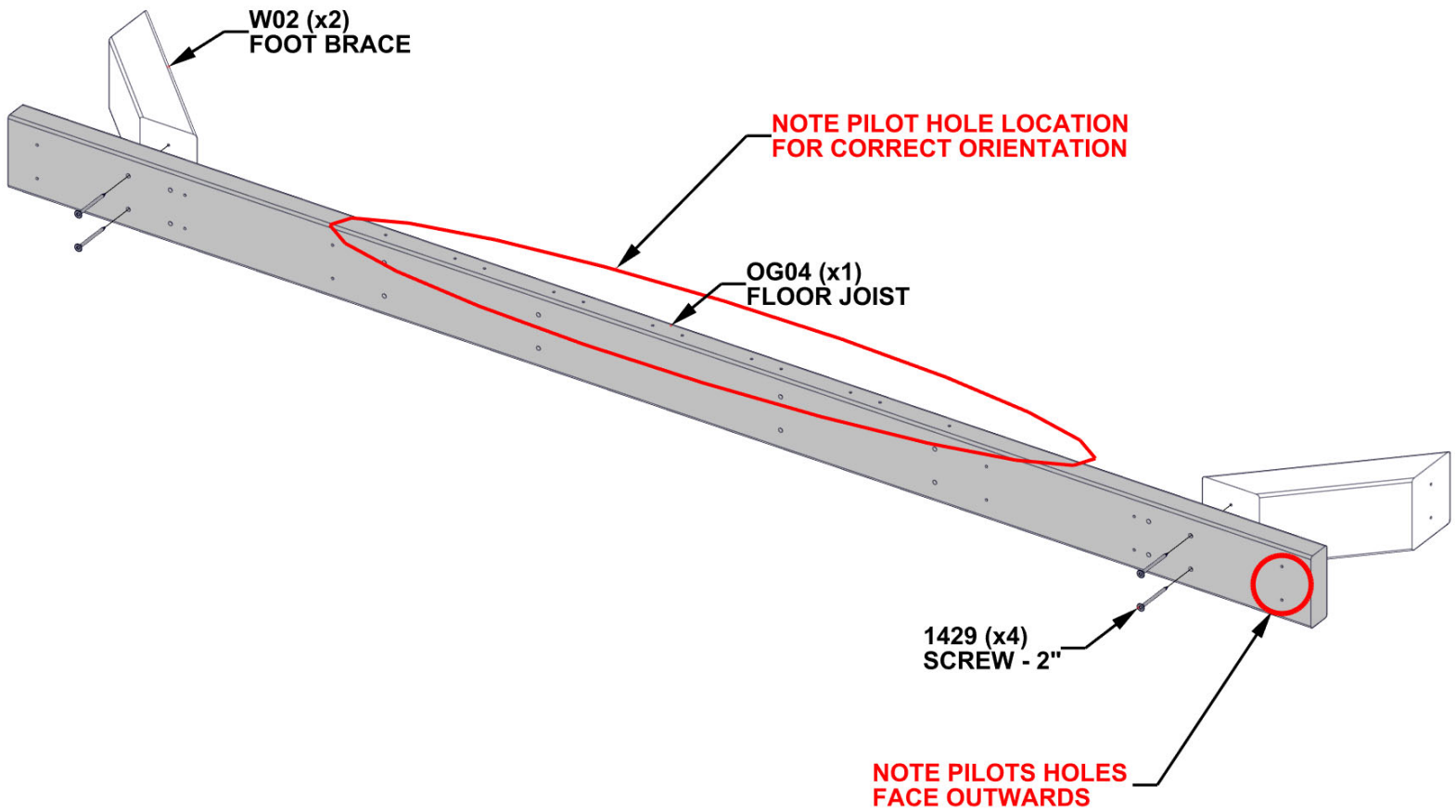

STEP 4 - FLOOR ASSEMBLY

QTY	PART NUMBER	DESCRIPTION
12	H101429	SCREW TFH 8X2 SS-BLK

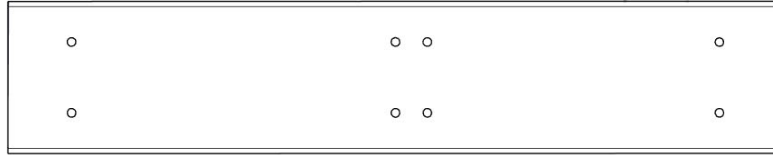

OG01 FLOOR JOIST - W4L22461
(x2) 1 3/16"x3 3/8"x17 1/4" (30x86x438)

- ALIGN PILOT HOLES.

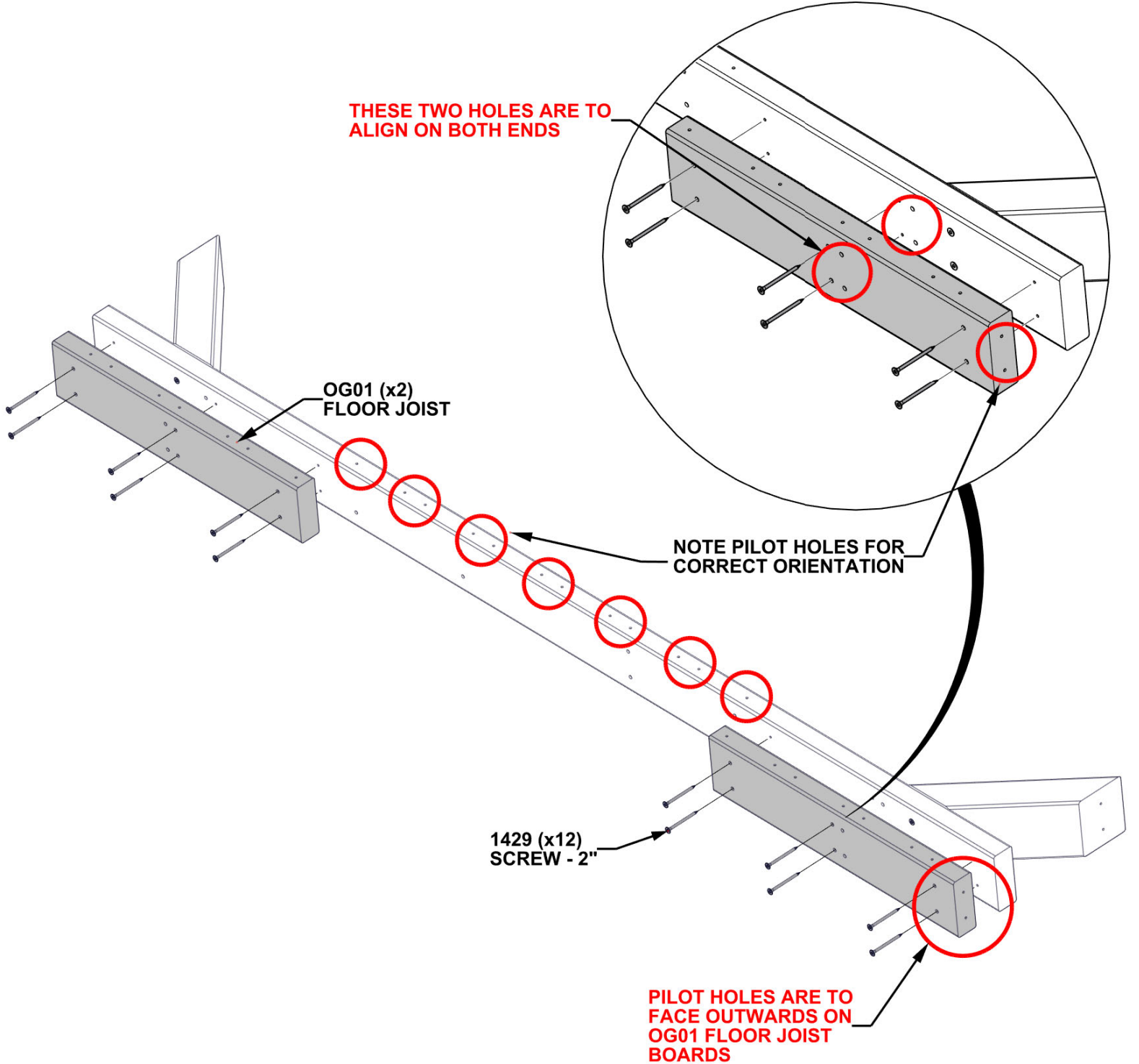

STEP 5 - FLOOR ASSEMBLY

QTY	PART NUMBER	DESCRIPTION
4	H101429	SCREW TFH 8X2 SS-BLK
4	H101430	SCREW TFH 8X2 1/4 SS-BLK

- ALIGN PILOT HOLES.
- SQUARE ASSEMBLY AND TIGHTEN ALL HARDWARE.

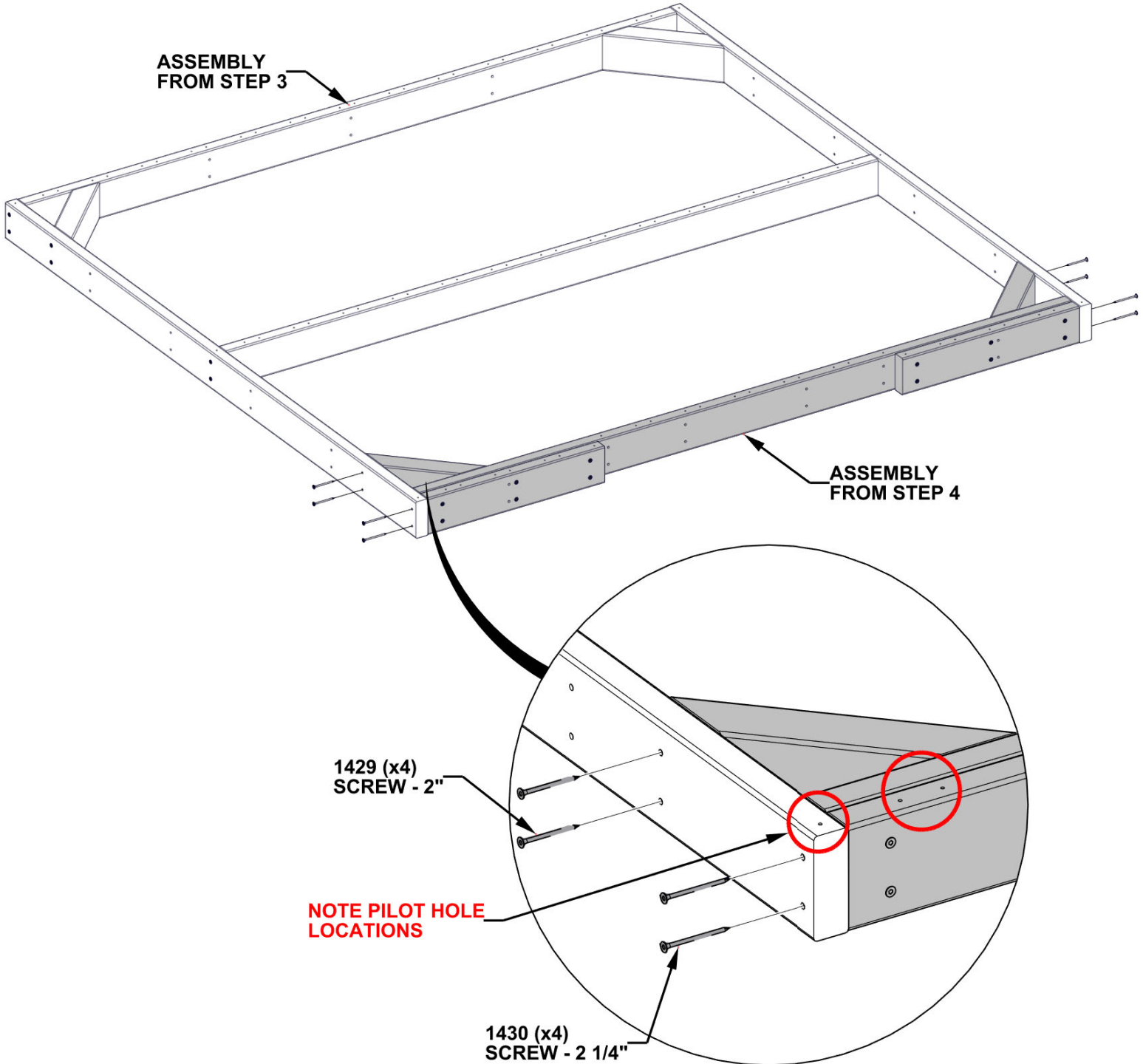

STEP 6 - FLOOR ASSEMBLY

QTY	PART NUMBER	DESCRIPTION
16	H101426	SCREW TFH 8X1 1/4 SS-BLK

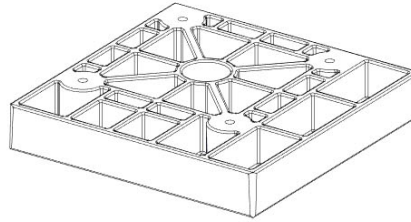

A6P01526 BASE FOOT
(x4)

- FLIP ASSEMBLY OVER AND ATTACH FEET AS SHOWN.
- NOTE THAT PILOT HOLES WILL FACE DOWNWARDS BEFORE ATTACHING FEET.
- USE DIMENSIONS SHOWN AND DRILL A 1/8" [3mm] PILOT HOLES FOR THE ATTACHMENT OF HARDWARE.

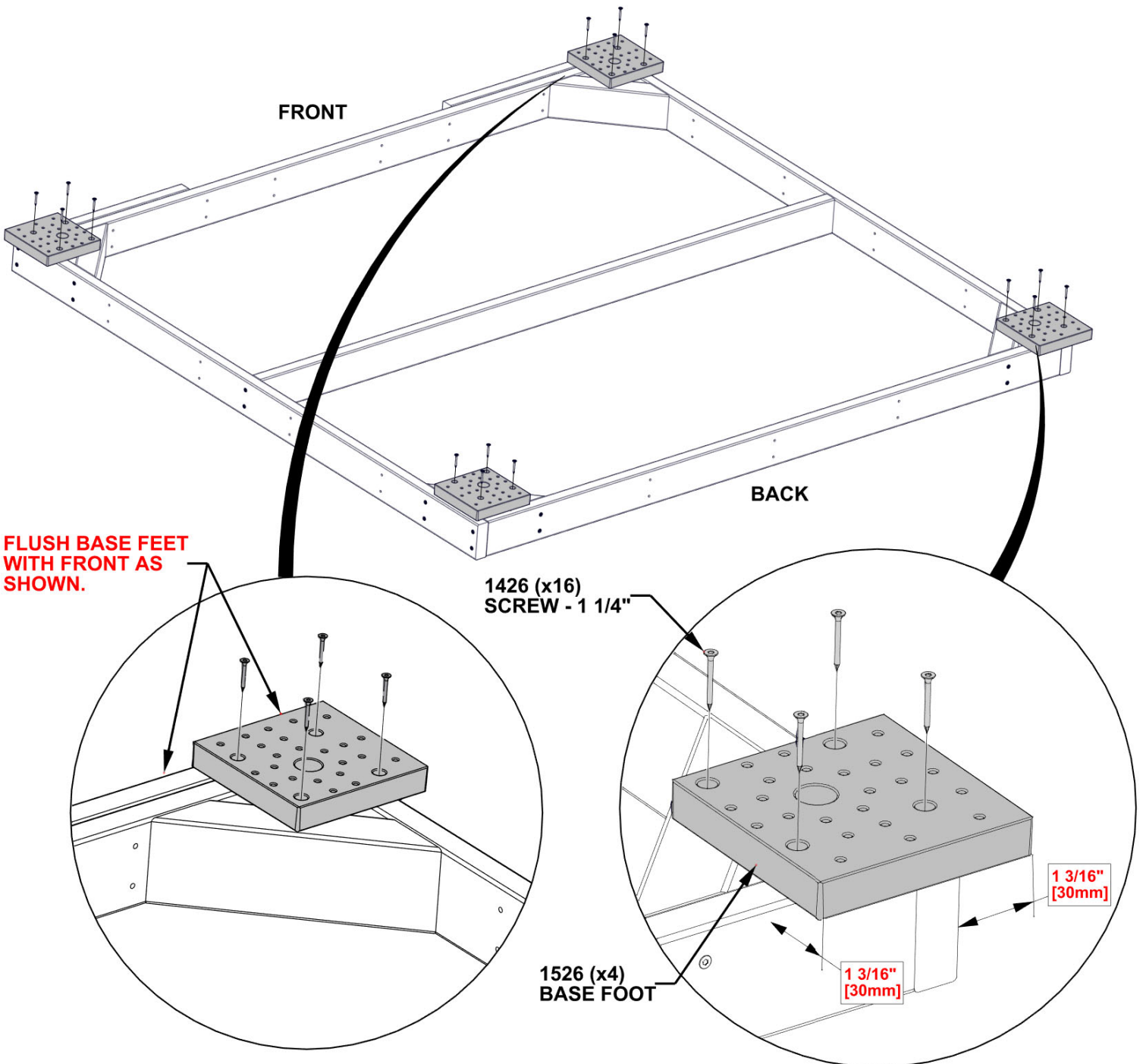

STEP 8 - WALL ASSEMBLY

QTY	PART NUMBER	DESCRIPTION
4	H100379	TNUT-5/16" BLK
63	H101429	SCREW TFH 8X2 SS-BLK

OJ01	WALL BOARD - W4L22347	(x1) 1 3/16"x5 1/4"x63 1/16" (30x134x1602)
OJ02	WALL BOARD - W4L22348	(x14) 1 3/16"x5 1/4"x63 1/16" (30x134x1602)
OJ09	WALL BOARD - W4L22357	(x1) 1 3/16"x5 1/4"x63 1/16" (30x134x1602)

SP02	POST - W4L22342	(x1) 3 3/8"x3 3/8"x77 13/16" (86x86x1976)
SP03	POST - W4L22343	(x1) 3 3/8"x3 3/8"x73 5/16" (86x86x1862)

- INSERT TNUTS IN POST FIRST (SEE IMPORTANT NOTE BELOW).
- LAY WALL BOARDS IN GROOVE IN POSTS AS SHOWN.
- EVENLY SPACE WALL BOARDS.
- HOLD DIMENSION AND TIGHTEN HARDWARE.

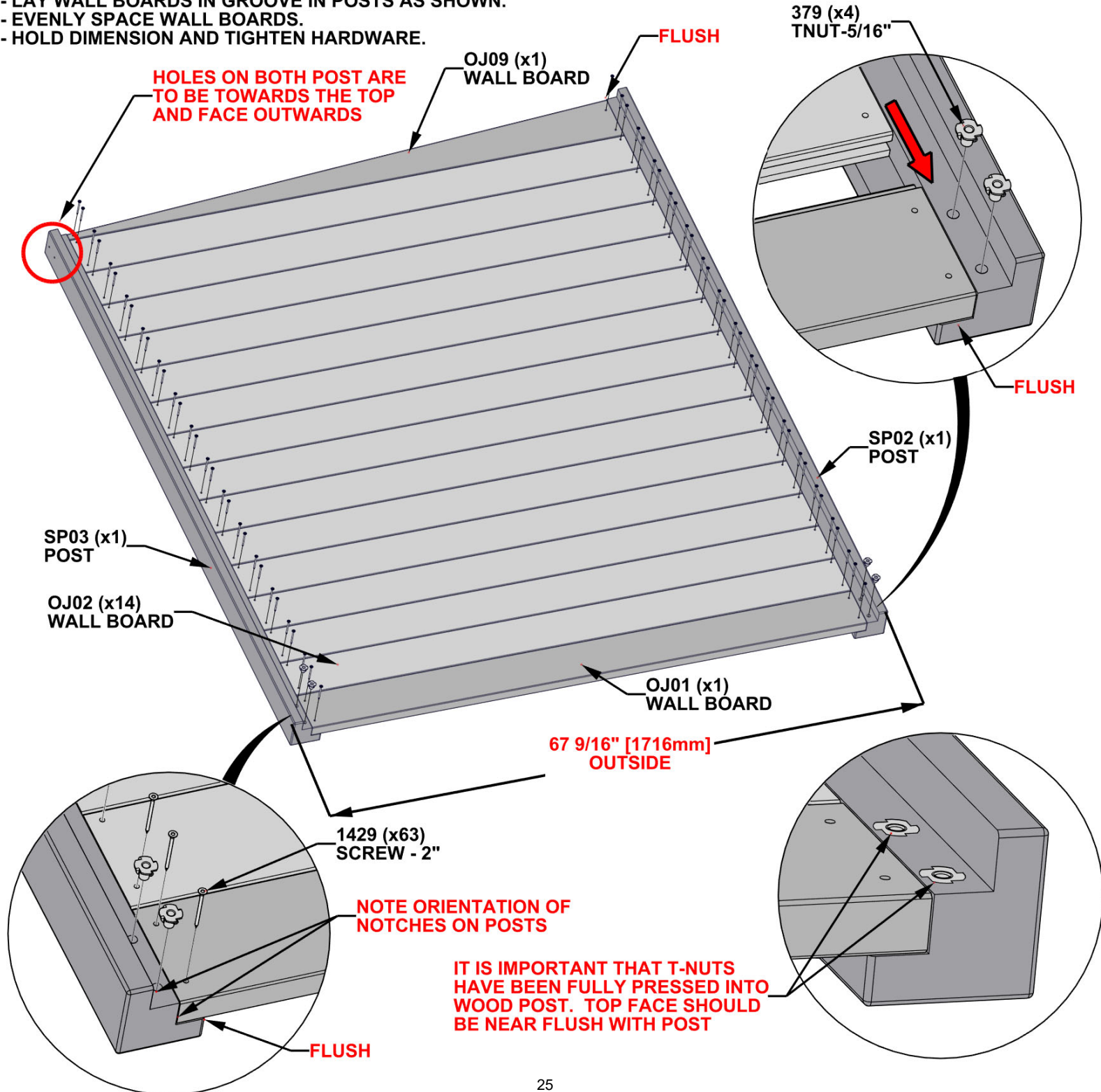

STEP 9 - WALL ASSEMBLY

QTY	PART NUMBER	DESCRIPTION
20	H101429	SCREW TFH 8X2 SS-BLK



E01 TRIM BOARD - W4L22459
(x2) 1 7/16"x3 3/8"x78 1/8" (36x86x1984)



HB01 WALL BOARD - W4L22456
(x2) 15/16"x2 3/4"x63 9/16" (24x70x1614)

- ALIGN HOLES IN BOARD HB01 WITH PILOT HOLES IN BOARD E01, THEN FASTEN AS SHOWN.
- REPEAT THIS STEP TWICE.

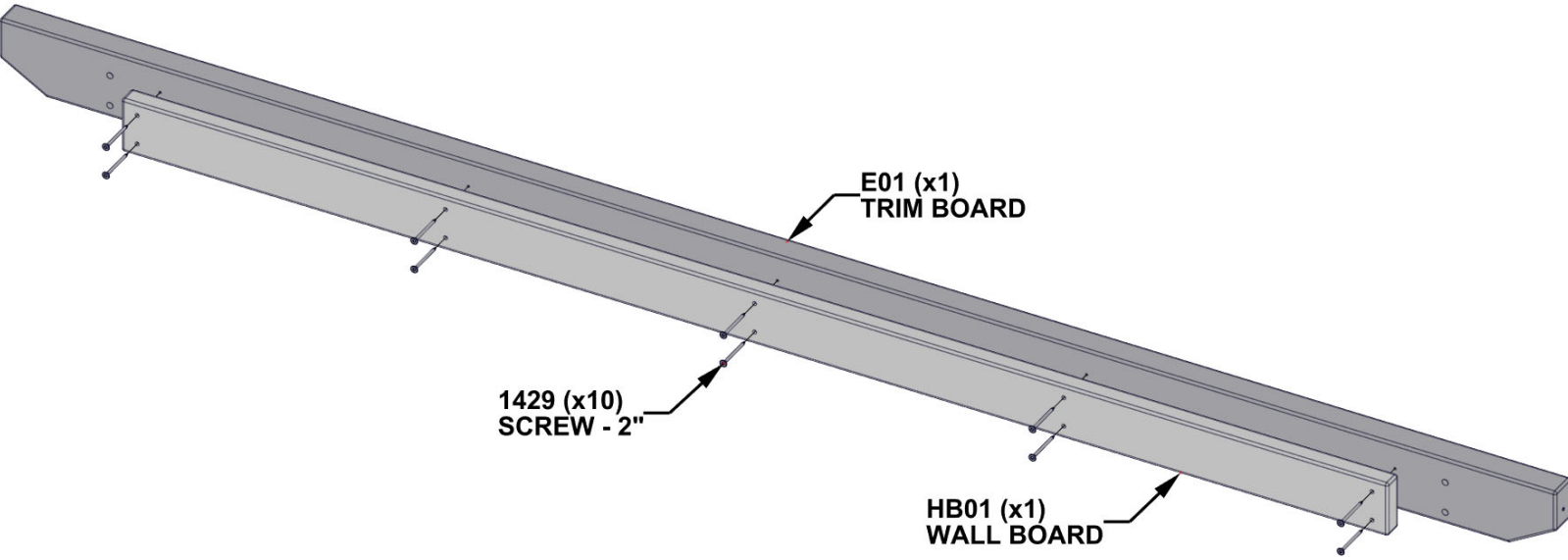

STEP 10 - SAUNA ASSEMBLY

- FRONT OF ASSEMBLY IS DETERMINED BY TALLER POST.
- EXTRA PEOPLE MAY BE NEEDED FOR THIS STEP.
- STAND BOTH LEFT AND RIGHT WALL UP AND PUSHED AGAINST FLOOR FRAME.
- NOTE THE FRONT OF THE FLOOR FRAME WILL HAVE OG03 FLOOR JOIST AS SHOWN.

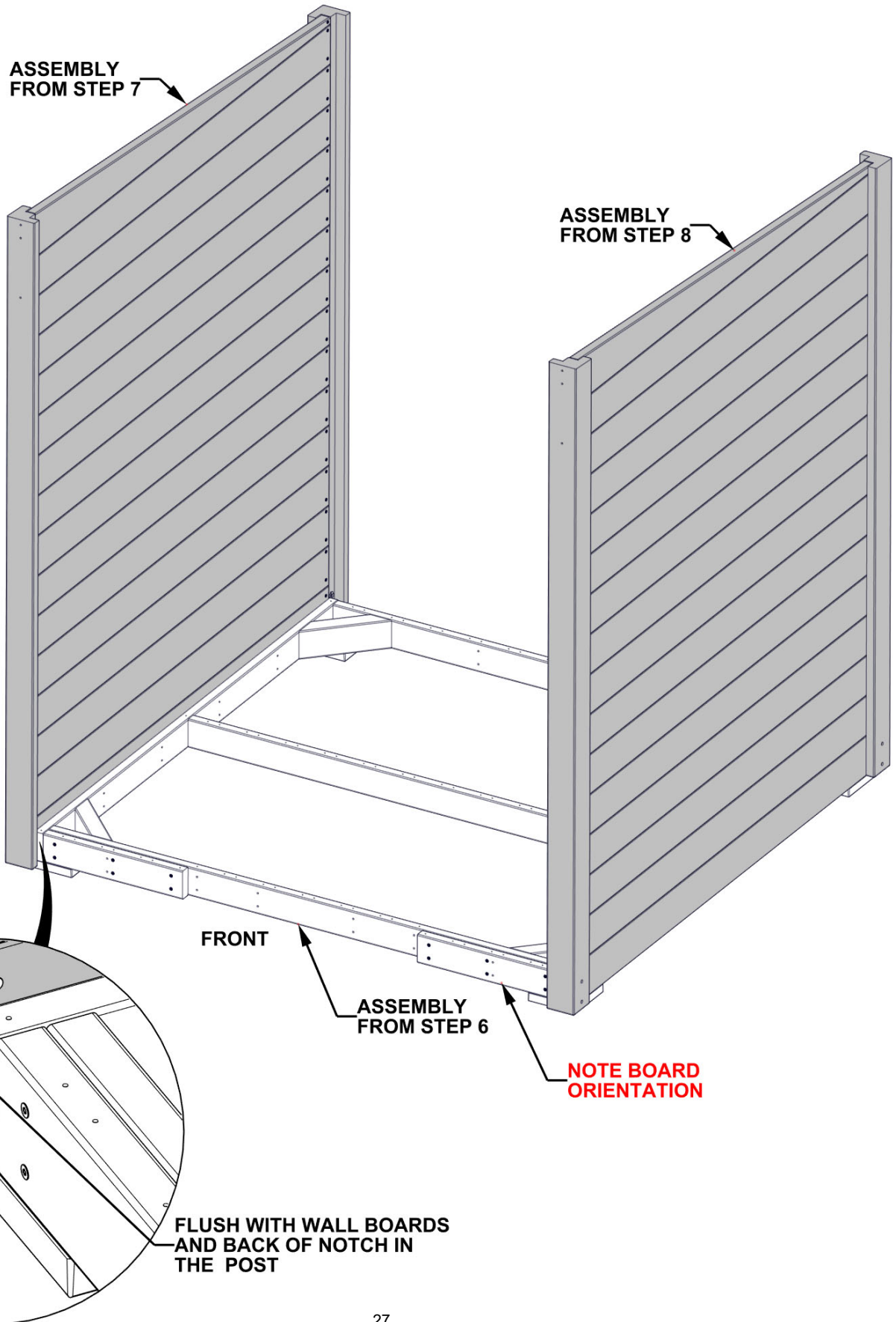

STEP 11 - SAUNA ASSEMBLY

QTY	PART NUMBER	DESCRIPTION
8	H100405	WASHER LOCK EXT 6x15
8	H100487	LAG SCREW WH 1/4x2 BLK

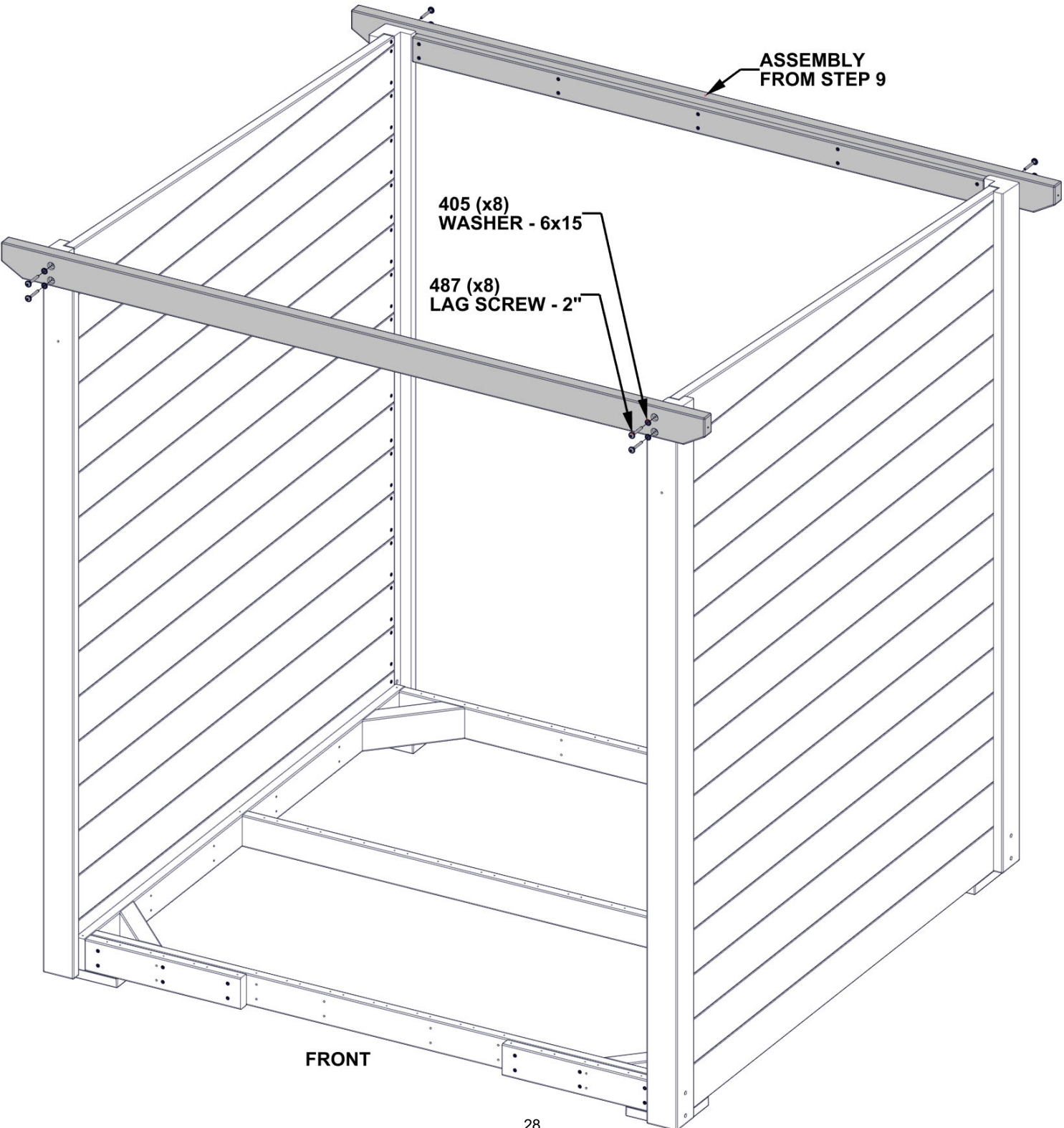

STEP 12 - SAUNA ASSEMBLY

- MAKE SURE FLOOR FRAME IS SQUARE AND LEVEL.
- CAREFULLY LIFT WALLS AND PLACE ON TOP OF FLOOR ASSEMBLY FEET. SEE DETAIL BELOW.
- MAINTAIN THE 1 3/16" [31mm] GAP SHOWN BELOW ON ALL FOUR POST, FRONT AND BACK.

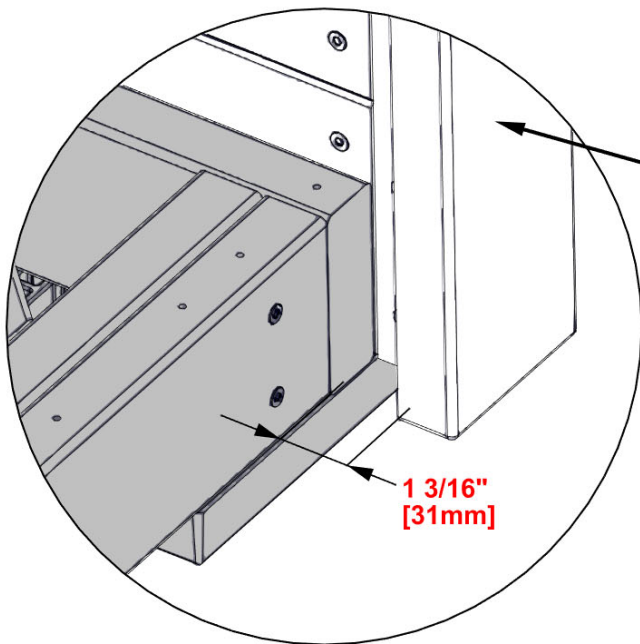
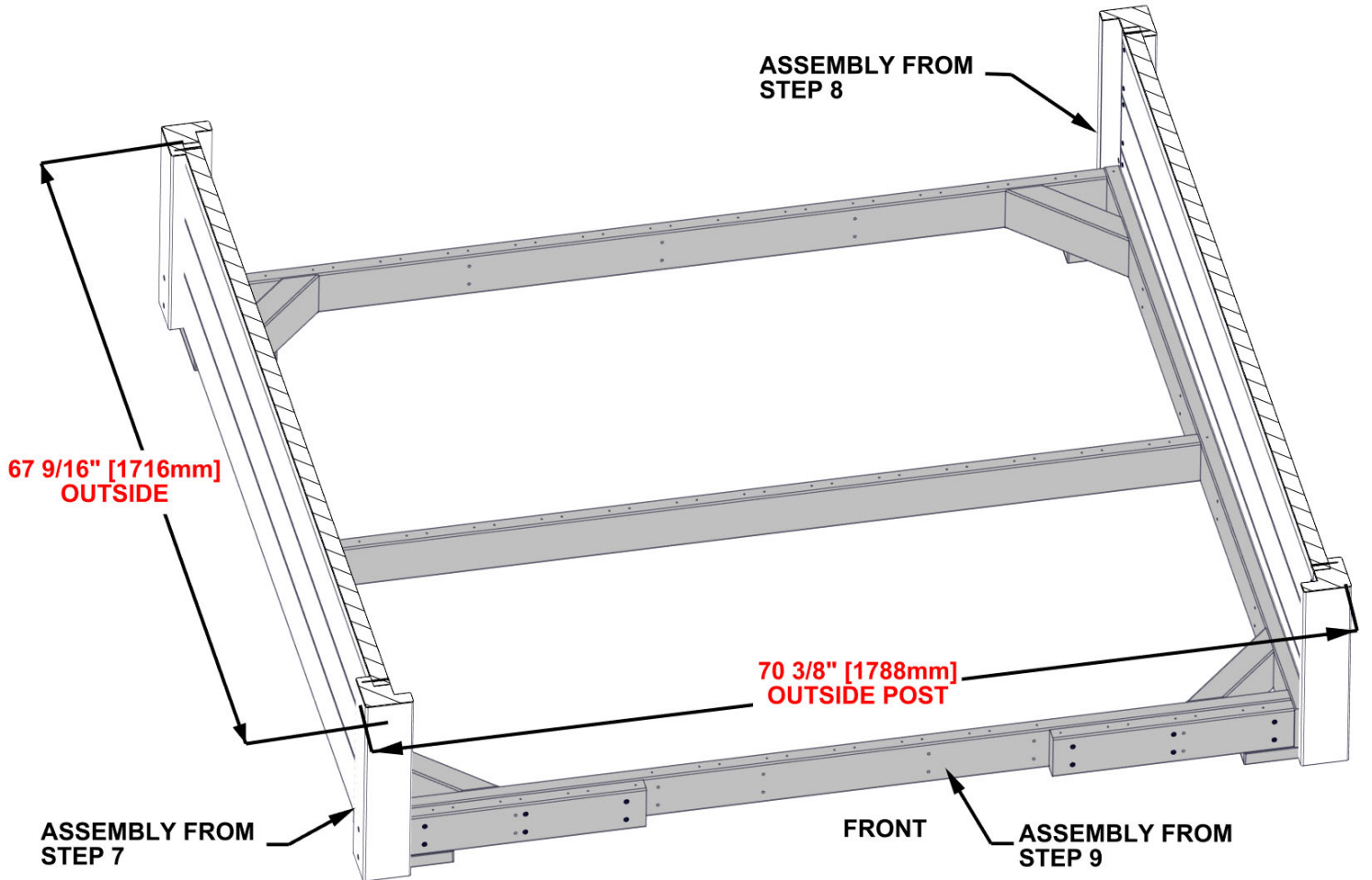

SIT WALL ASSEMBLIES ON TOP OF FLOOR ASSEMBLY FEET

ASSEMBLY FROM STEP 8 FRONT POST

WALL AND FLOOR FRAME ARE TO BE FLUSH

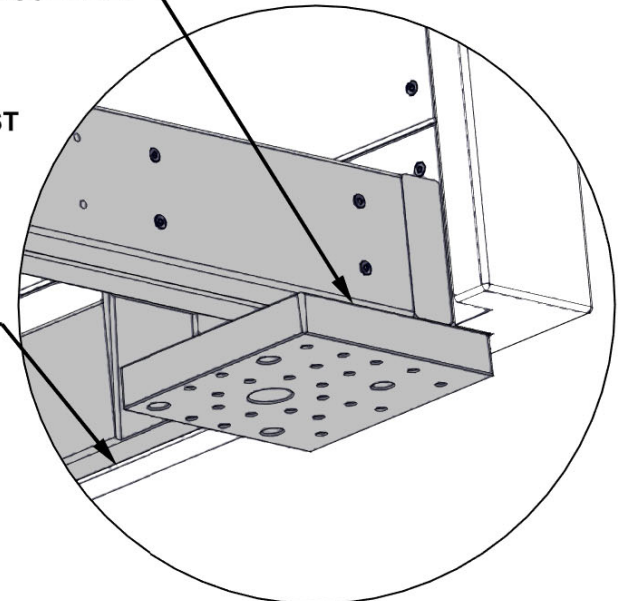

STEP 13 - SAUNA ASSEMBLY

QTY	PART NUMBER	DESCRIPTION
16	H101429	SCREW TFH 8X2 SS-BLK

- AFTER ENSURING THE FLOOR FRAMING AND WALLS ARE FLUSH, LEVEL AND SQUARE, SECURE THE FLOOR FRAME TO THE WALL ASSEMBLIES AS SHOWN.

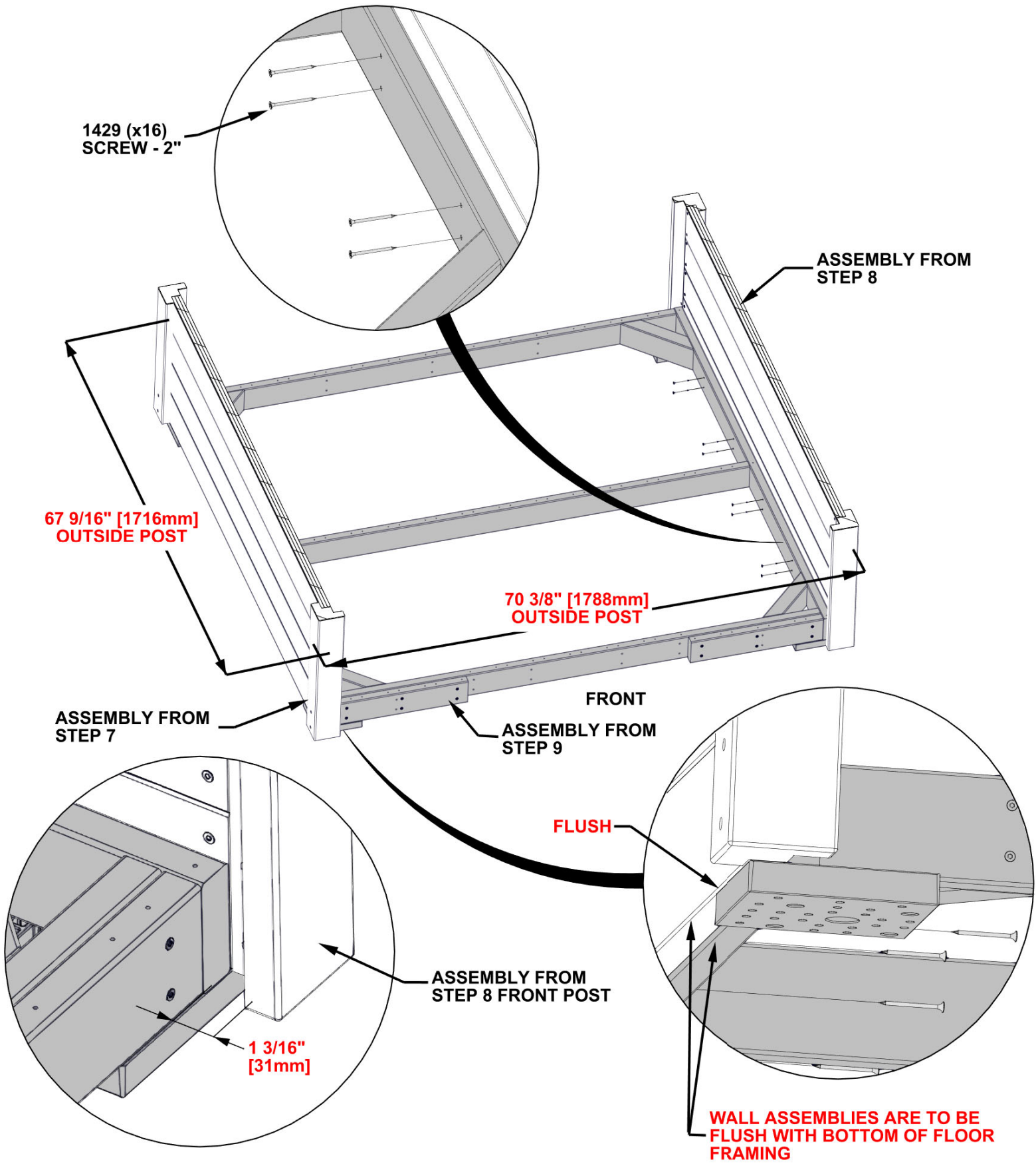

STEP 14 - WALL ASSEMBLY

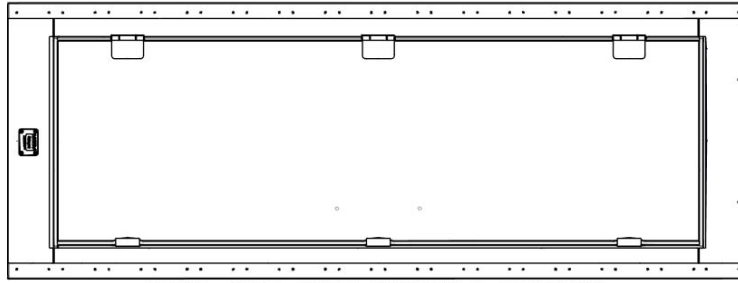

WP01 WALL PANEL ASSEMBLY - W2A04926
(x1) 2 3/8"x28 7/8"x77 5/8" (60x734x1972)

- BRING DOOR WALL PANEL ASSEMBLY IN FROM THE BACK AND TILT SLIGHTLY WHILE SLIDING DOWN IN BETWEEN THE TWO BOARDS ATTACHED TO FLOOR FRAME AS SHOWN.

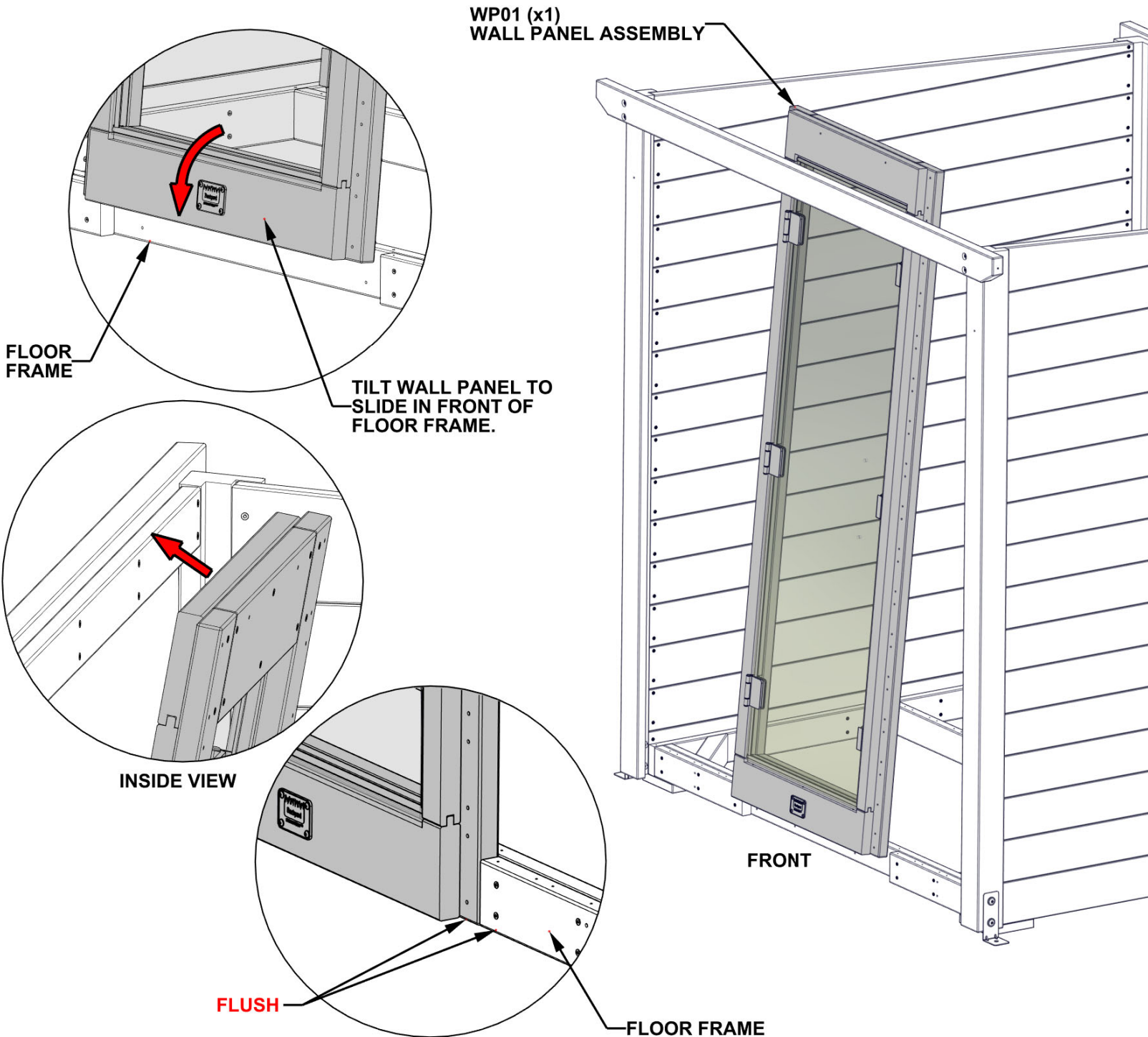

STEP 15 - WALL ASSEMBLY

QTY	PART NUMBER	DESCRIPTION
4	H101434	SCREW TFH 8X3 1/4 SS-BLK
2	H101435	SCREW TFH 8X3 1/2 SS-BLK

- IT IS IMPORTANT TO DOUBLE CHECK TO ENSURE THE FLOOR, WALLS AND WALL PANEL ARE SQUARE AND LEVEL BEFORE ATTACHING WALL PANEL.
- ENSURE THAT BOTTOM OF DOOR FRAME WALL PANEL IS FLUSH WITH BOTTOM OF FLOOR ASSEMBLY (SEE DETAIL)

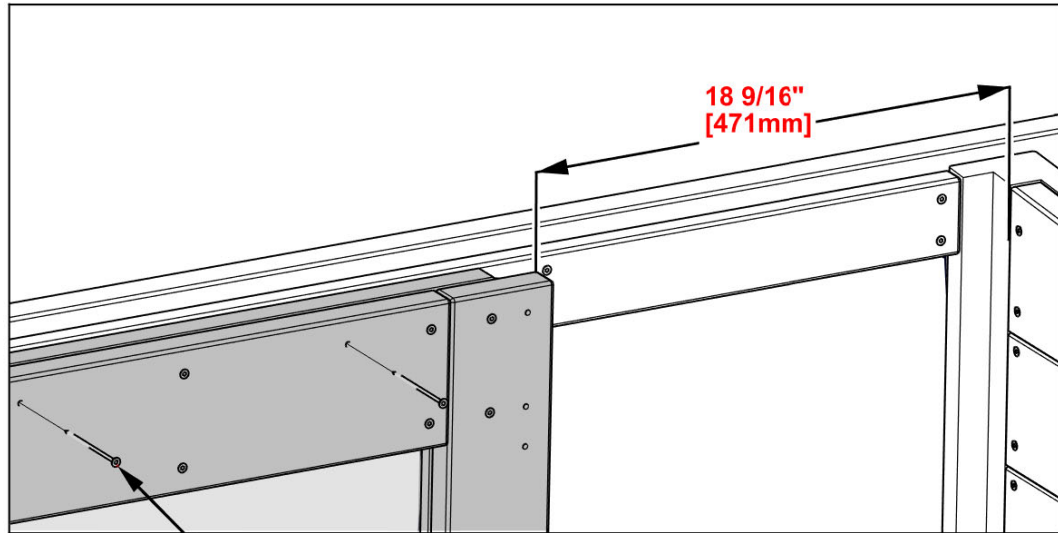

1435 (x2)
SCREW - 3 1/2"

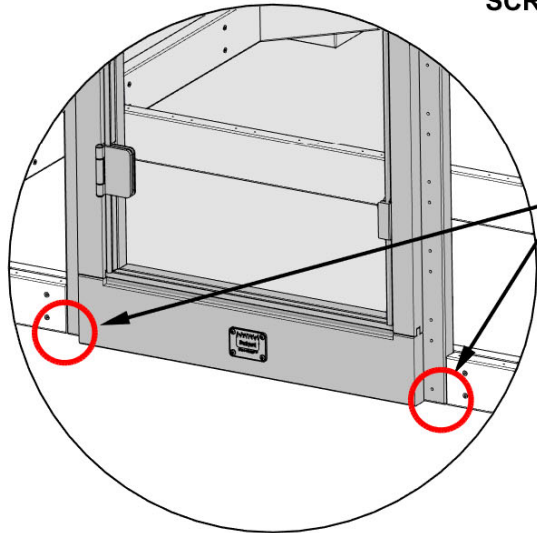

WALL PANEL ASSEMBLY IS TO BE FLUSH WITH BOTTOM OF FLOOR FRAME

FRONT VIEW

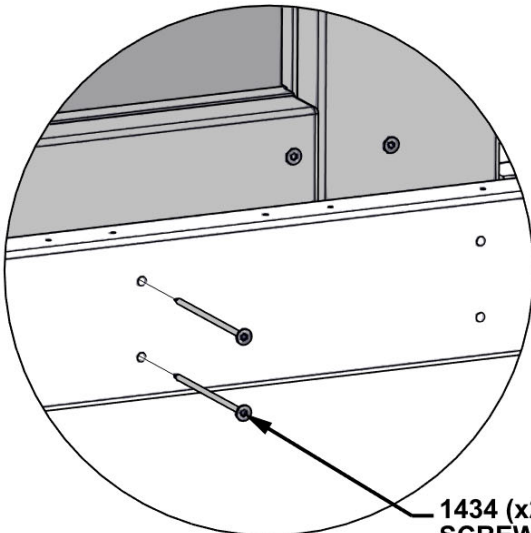

1434 (x2)
SCREW - 3 1/4"

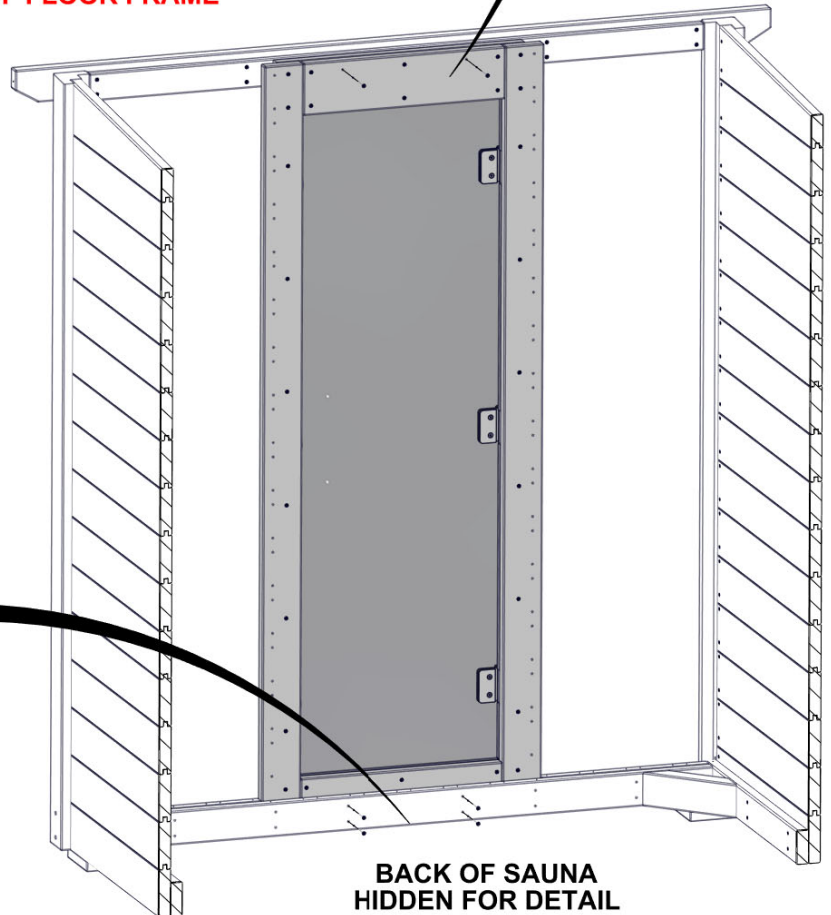

BACK OF SAUNA
HIDDEN FOR DETAIL

STEP 16 - WALL ASSEMBLY

QTY	PART NUMBER	DESCRIPTION
61	H101429	SCREW TFH 8X2 SS-BLK
4	H101434	SCREW TFH 8X3 1/4 SS-BLK



OJ11 WALL BOARD - W4L22477
(x1) 1 3/16"x5 1/4"x20 1/8" (30x134x511)



OJ12 WALL BOARD - W4L22478
(x14) 1 3/16"x5 1/4"x20 1/8" (30x134x511)



OJ16 WALL BOARD - W4L22482
(x1) 1 3/16"x5 1/4"x20 1/8" (30x134x511)

- SLIDE OJ11 BETWEEN FLOOR FRAME AND POST.
- OJ11 IS TO BE FLUSH WITH BOTTOM OF FLOOR FRAME AND DOOR WALL PANEL ASSEMBLY AND LEVEL.
- ATTACH OJ11 AS SHOWN.
- STACK OTHER WALL BOARDS ON TOP AS SHOWN.
- ALIGN PILOT HOLES IN WALL BOARDS WITH THROUGH HOLES IN DOOR WALL PANEL ASSEMBLY AND ATTACH AS SHOWN.

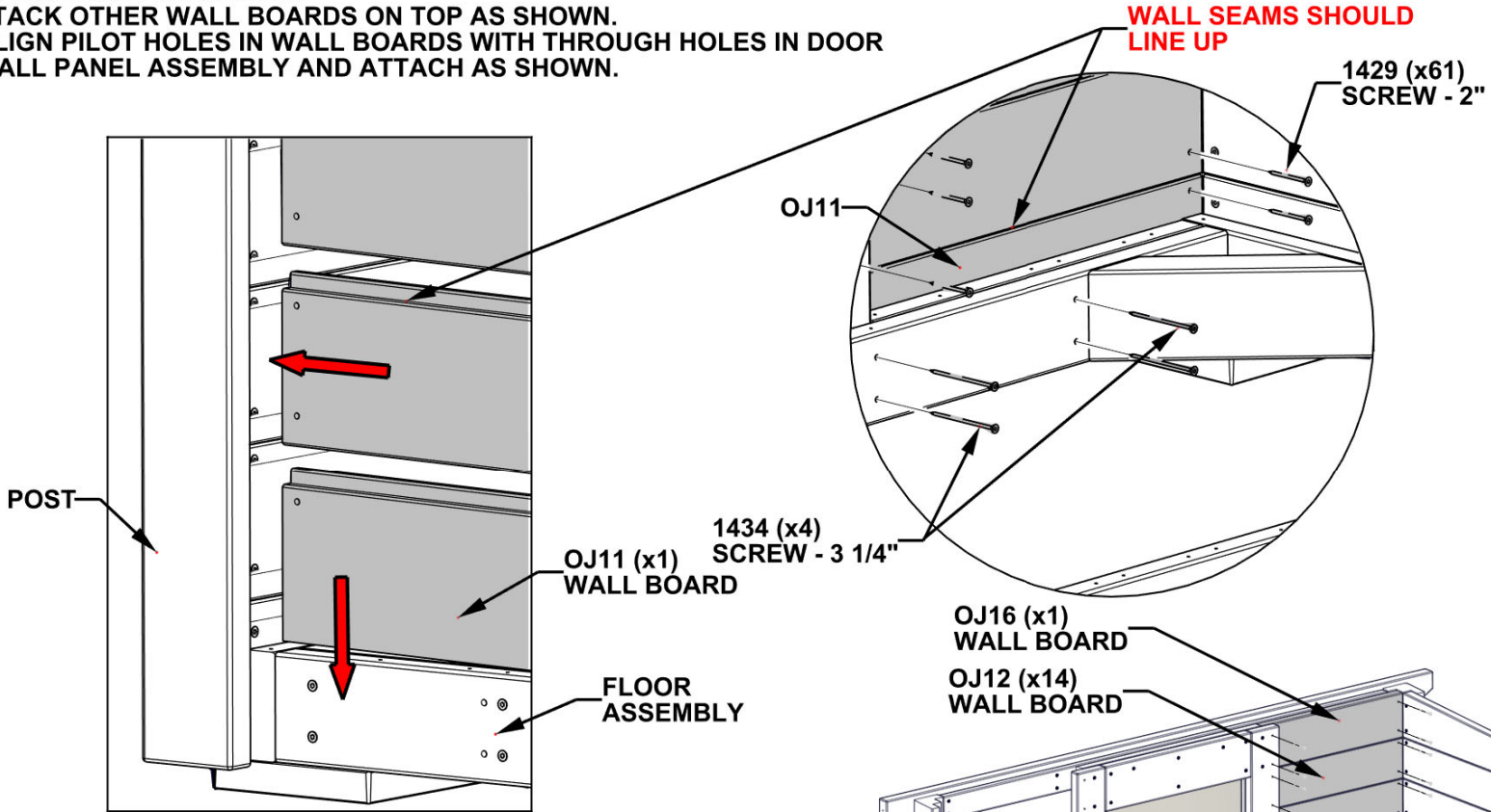

OUTSIDE VIEW

ENSURE THAT WALL BOARD IS FLUSH WITH BOTTOM OF POST AND WALL PANEL ASSEMBLY

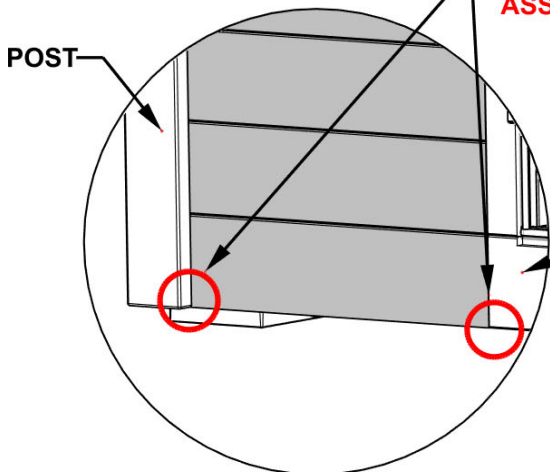

OUTSIDE VIEW

DOOR WALL PANEL ASSEMBLY

RIGHT WALL ASSEMBLY HIDDEN FOR DETAIL

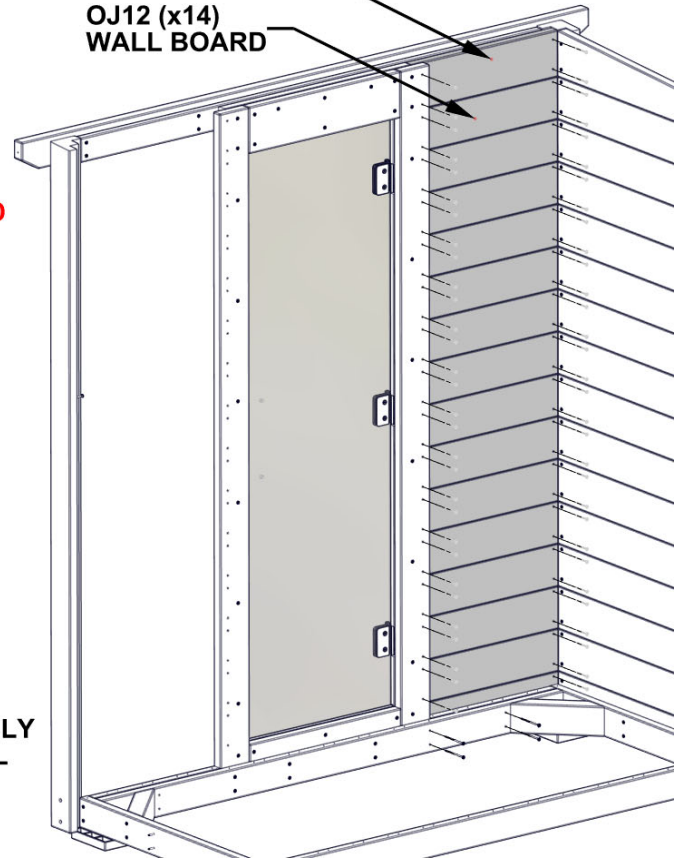

STEP 17 - WALL ASSEMBLY

QTY	PART NUMBER	DESCRIPTION
29	H101429	SCREW TFH 8X2 SS-BLK
4	H101434	SCREW TFH 8X3 1/4 SS-BLK



OJ03 WALL BOARD - W4L22471
(x1) 1 3/16"x5 1/4"x20 1/8" (30x134x511)



OJ04 WALL BOARD - W4L22472
(x6) 1 3/16"x5 1/4"x20 1/8" (30x134x511)

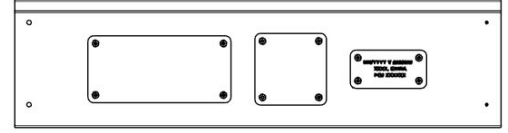

WB01 WALL BOARD ASSEMBLY - W2A05157
(x1) 1 3/16"x5 1/4"x20 1/8" (30x134x511)

- SLIDE OJ03 BETWEEN FLOOR FRAME AND POST.
- OJ03 IS TO BE FLUSH WITH BOTTOM OF FLOOR FRAME AND DOOR WALL PANEL ASSEMBLY AND LEVEL.
- ATTACH OJ03 AS SHOWN.
- STACK OTHER WALL BOARDS ON TOP AS SHOWN.
- ALIGN PILOT HOLES IN WALL BOARDS WITH THROUGH HOLES IN DOOR WALL PANEL ASSEMBLY AND ATTACH AS SHOWN.

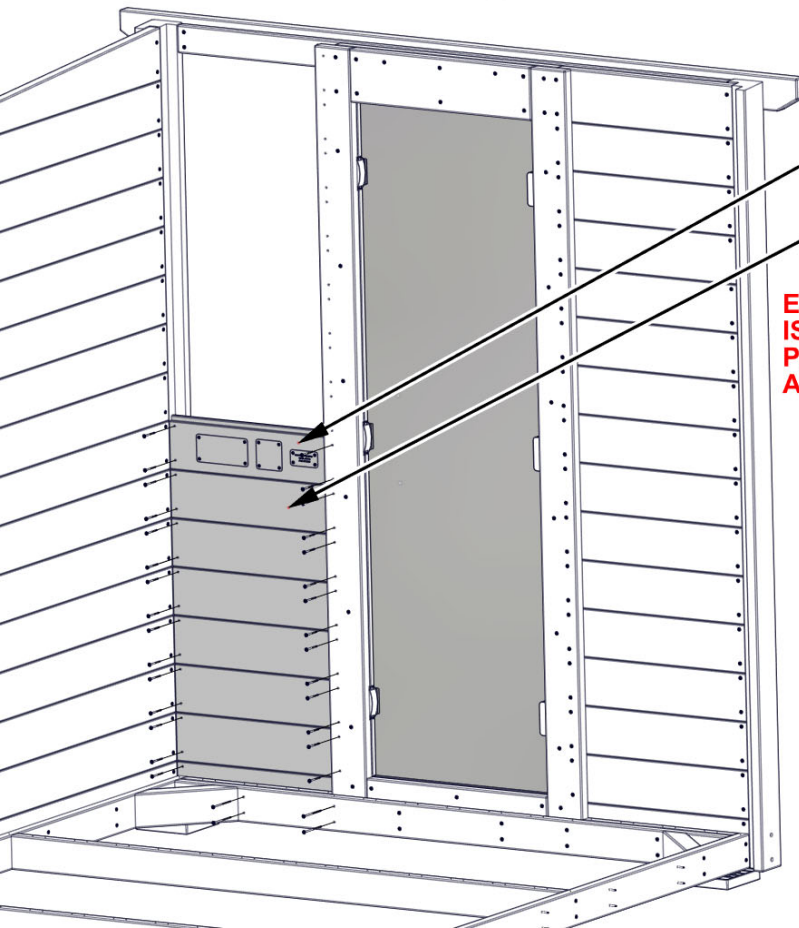
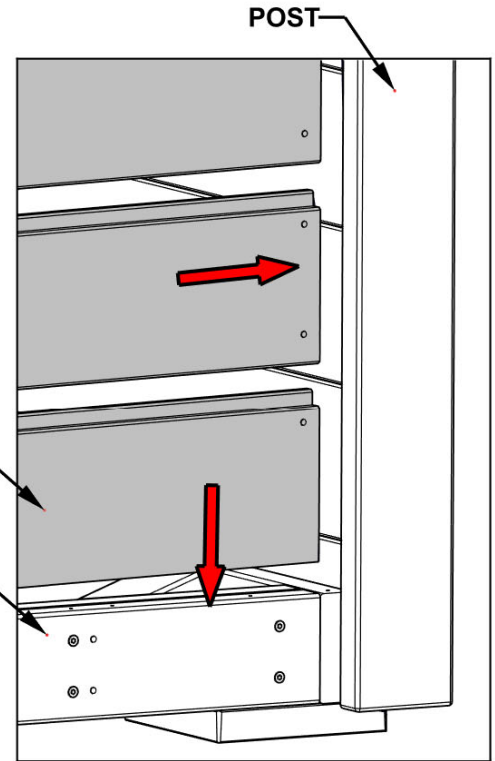
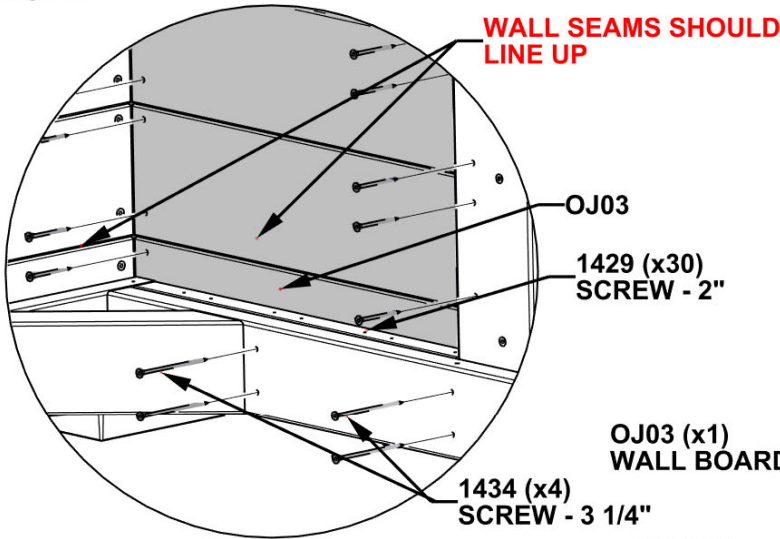

ENSURE THAT WALL BOARD IS FLUSH WITH BOTTOM OF POST AND WALL PANEL ASSEMBLY

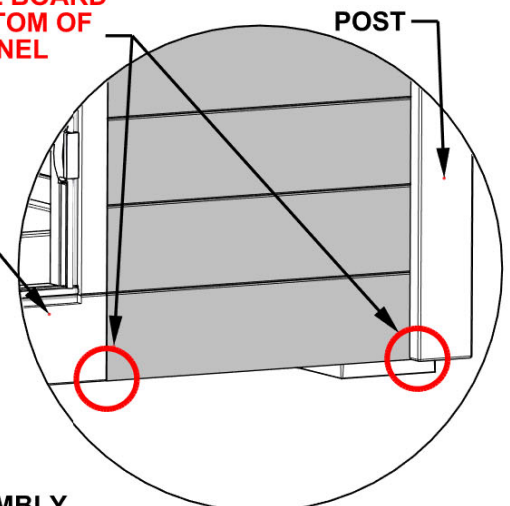

STEP 18 - WALL ASSEMBLY

QTY	PART NUMBER	DESCRIPTION
32	H101429	SCREW TFH 8X2 SS-BLK



OJ04 WALL BOARD - W4L22472
(x4) 1 3/16"x5 1/4"x20 1/8" (30x134x511)



OJ05 WALL BOARD - W4L22473
(x1) 1 3/16"x5 1/4"x20 1/8" (30x134x511)

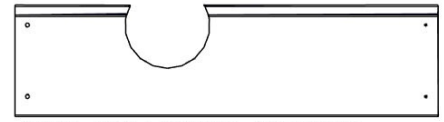

OJ06 WALL BOARD - W4L22474
(x1) 1 3/16"x5 1/4"x20 1/8" (30x134x511)

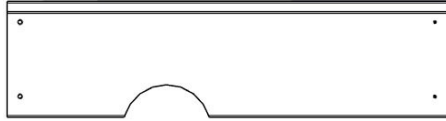

OJ07 WALL BOARD - W4L22475
(x1) 1 3/16"x5 1/4"x20 1/8" (30x134x511)



OJ08 WALL BOARD - W4L22476
(x1) 1 3/16"x5 1/4"x20 1/8" (30x134x511)

- STACK REMAINING WALL BOARDS AS SHOWN. NOTE THRU HOLE PLACEMENT.
- ALIGN PILOT HOLES IN WALL BOARDS WITH THROUGH HOLES IN DOOR WALL PANEL ASSEMBLY AND ATTACH AS SHOWN.
- THE LAST WALL BOARD OJ08 WILL NEED TO SLIDE IN FROM THE TOP OF THE DOOR WALL PANEL ASSEMBLY.

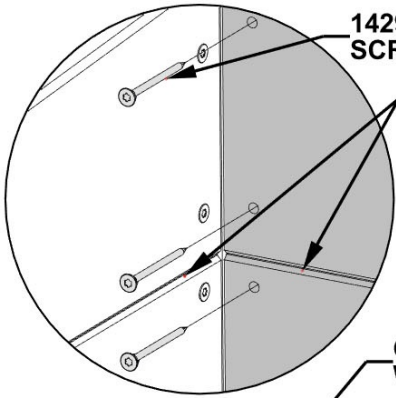

1429 (x32)
SCREW - 2"

**WALL SEAMS SHOULD
LINE UP**

OJ08 (x1)
WALL BOARD

OJ07 (x1)
WALL BOARD

OJ06 (x1)
WALL BOARD

OJ05 (x1)
WALL BOARD

**NOTE THROUGH HOLES FOR
PROPER PLACEMENT OF
WALL BOARDS**

OJ04 (x4)
WALL BOARD

WALL PANEL
ASSEMBLY

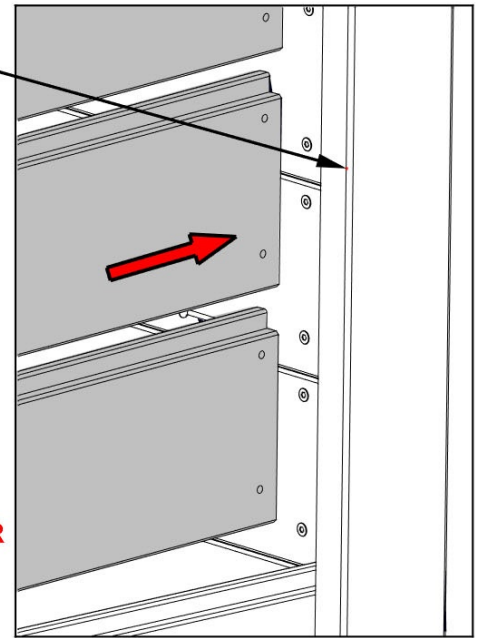

OUTSIDE VIEW

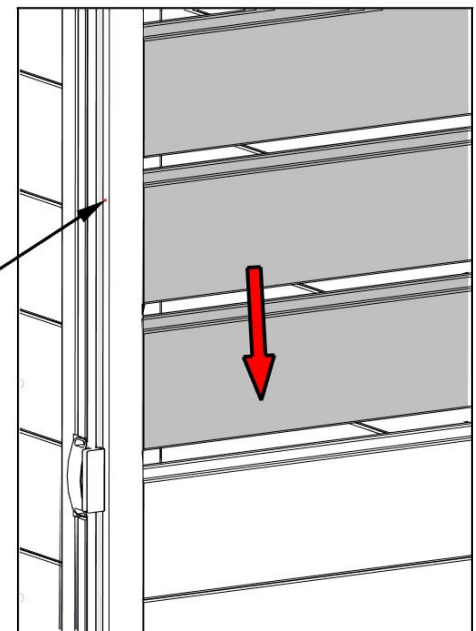

OUTSIDE VIEW

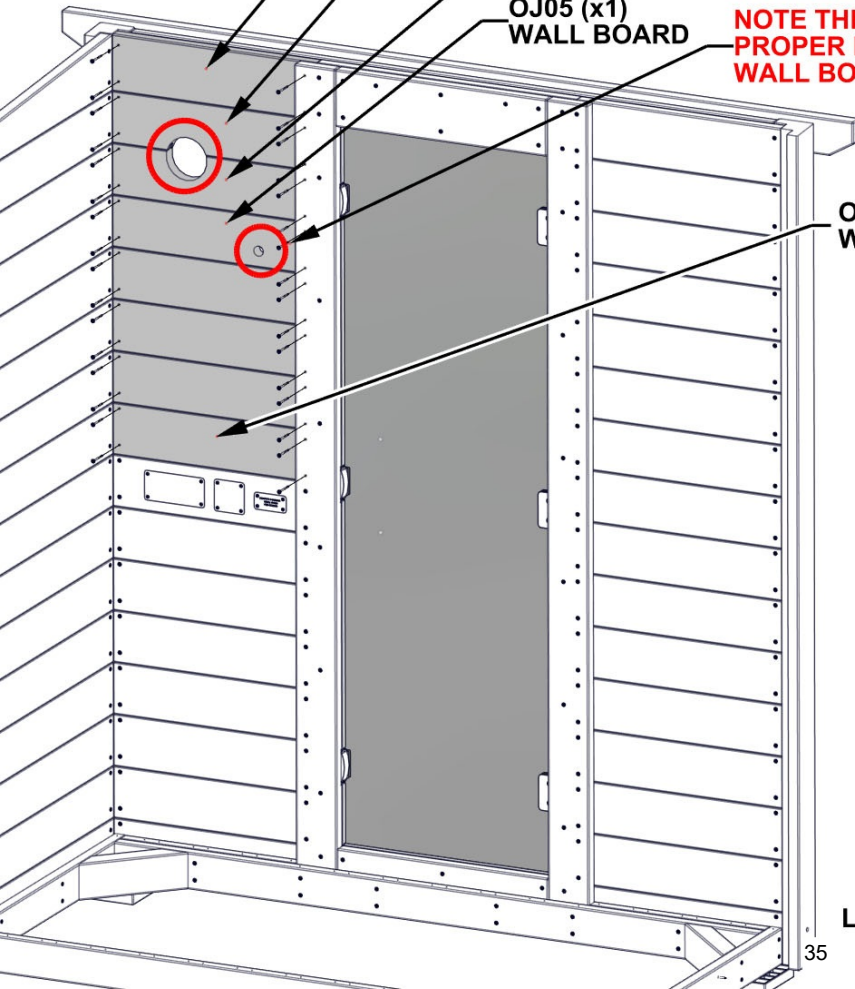

LEFT WALL ASSEMBLY
HIDDEN FOR DETAIL

STEP 19 - WALL ASSEMBLY

QTY	PART NUMBER	DESCRIPTION
14	H101429	SCREW TFH 8X2 SS-BLK

OJ19 WALL BOARD - W4L22486
(x1) 1 3/16"x5 1/4"x65 7/8" (30x134x1674)

OJ22 WALL BOARD - W4L22489
(x1) 1 3/16"x5 1/4"x65 7/8" (30x134x1674)

OJ24 WALL BOARD - W4L22491
(x1) 1 3/16"x5 1/4"x65 7/8" (30x134x1674)

OJ25 WALL BOARD - W4L22492
(x1) 1 3/16"x5 1/4"x65 7/8" (30x134x1674)

- SLIDE OJ19 BETWEEN FLOOR FRAME AND POSTS UNTIL IT REST ON TOP OF FLOOR ASSEMBLY FOOT.
- ENSURE THAT OJ19 IS FLUSH WITH BOTTOM OF FLOOR FRAME AND LEVEL.
- ATTACH OJ19 AS SHOWN.
- STACK OTHER WALL BOARDS ON TOP OF OJ19 AND FASTEN AS SHOWN.

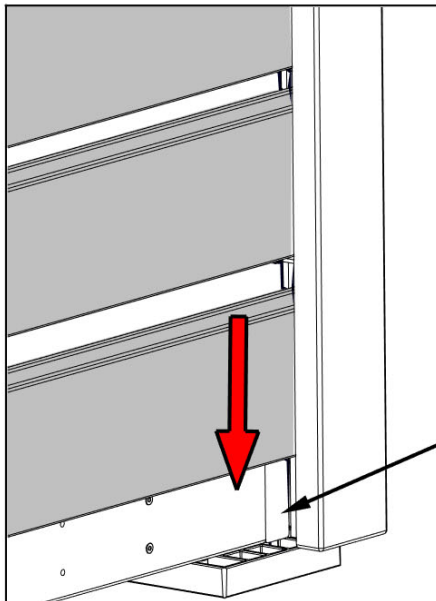
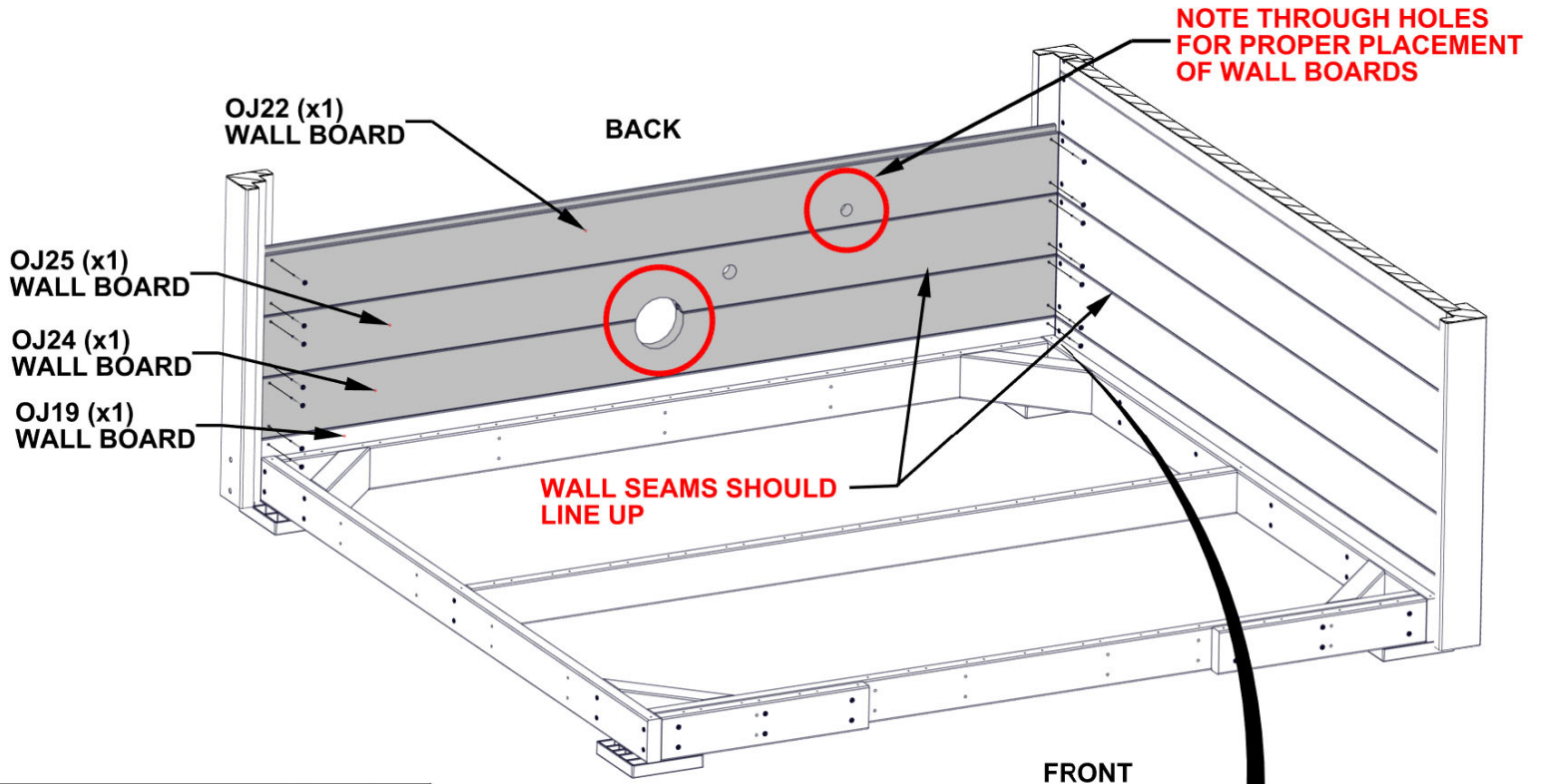

OUTSIDE VIEW

LEFT WALL AND FRONT WALL HIDDEN FOR DETAIL

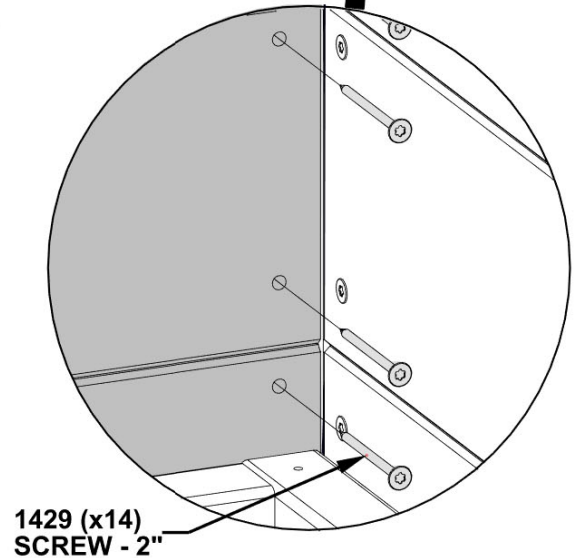

STEP 20 - WALL ASSEMBLY

QTY	PART NUMBER	DESCRIPTION
50	H101429	SCREW TFH 8X2 SS-BLK



OJ20 WALL BOARD - W4L22487
(x10) 1 3/16"x5 5/16"x65 7/8" (30x134x1674)



OJ21 WALL BOARD - W4L22488
(x1) 1 3/16"x5 1/4"x65 7/8" (30x134x1674)

- EVENLY SPACE REMAINING WALL BOARDS AS SHOWN. NOTE THROUGH HOLE PLACEMENTS.
- ATTACH WALL BOARDS TO POSTS AS SHOWN.

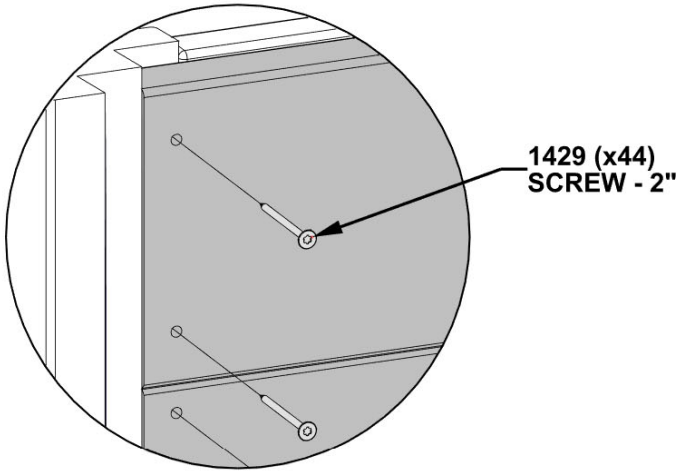

**WALL SEAMS SHOULD
LINE UP**

OJ21 (x1)
WALL BOARD

18"
[457mm]

**NOTE THROUGH HOLES
FOR PROPER PLACEMENT
OF WALL BOARDS**

OJ20 (x10)
WALL BOARD

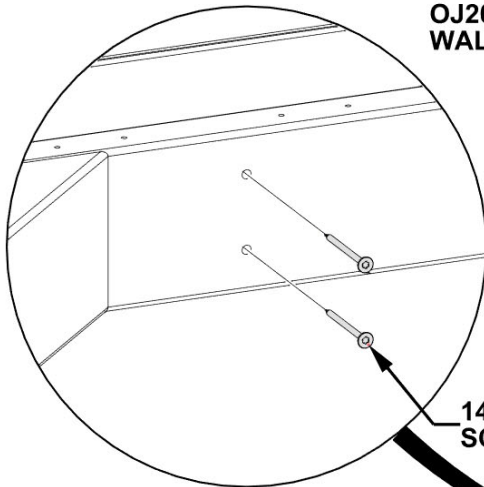

1429 (x6)
SCREW - 2"

**LEFT WALL ASSEMBLY
HIDDEN FOR DETAIL**

STEP 21 - FLOOR ASSEMBLY

QTY	PART NUMBER	DESCRIPTION
42	H101429	SCREW TFH 8X2 SS-BLK

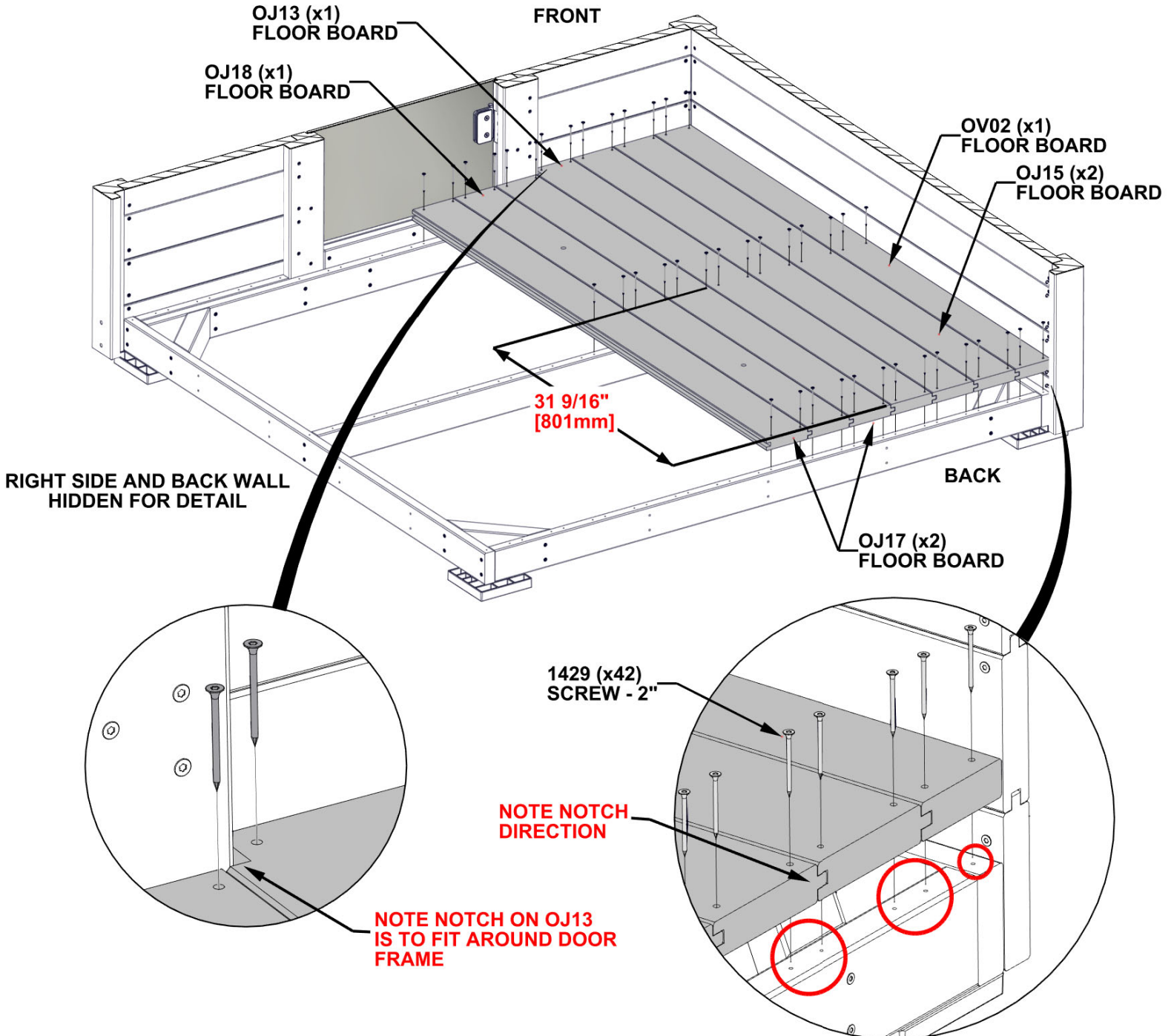

OJ13 FLOOR BOARD - W4L22479 (x1) 1 3/16"x5 1/4"x63 1/16" (30x134x1602)	OJ15 FLOOR BOARD - W4L22481 (x2) 1 3/16"x5 1/4"x63 1/16" (30x134x1602)	OJ17 FLOOR BOARD - W4L22483 (x2) 1 3/16"x5 1/4"x61 7/8" (30x134x1572)
OJ18 FLOOR BOARD - W4L22484 (x1) 1 3/16"x5 1/4"x61 7/8" (30x134x1572)	OV02 FLOOR BOARD - W4L22468 (x1) 1 3/16"x4 1/4"x63 1/16" (30x107x1602)	

- EVENLY SPACE FLOOR BOARDS.
- ALIGN HOLES IN FLOOR BOARDS WITH PILOT HOLES IN FLOOR FRAME AND ATTACH AS SHOWN.

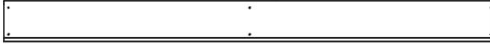
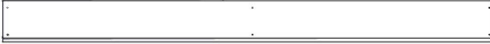
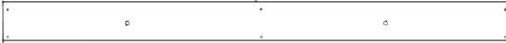

STEP 22 - FLOOR ASSEMBLY

QTY	PART NUMBER	DESCRIPTION
42	H101429	SCREW TFH 8X2 SS-BLK

 OJ14 FLOOR BOARD - W4L22480 (x1) 1 3/16"x5 1/4"x63 1/16" (30x134x1602)	 OJ15 FLOOR BOARD - W4L22481 (x2) 1 3/16"x5 1/4"x63 1/16" (30x134x1602)	 OJ17 FLOOR BOARD - W4L22483 (x2) 1 3/16"x5 1/4"x61 7/8" (30x134x1572)
 OJ18 FLOOR BOARD - W4L22484 (x1) 1 3/16"x5 1/4"x61 7/8" (30x134x1572)	 OS01 FLOOR BOARD - W4L22729 (x1) 1 3/16"x3 3/4"x63 1/16" (30x96x1602)	

- EVENLY SPACE FLOOR BOARDS.
- ALIGN HOLES IN FLOOR BOARDS WITH PILOT HOLES IN FLOOR FRAME AND ATTACH AS SHOWN.

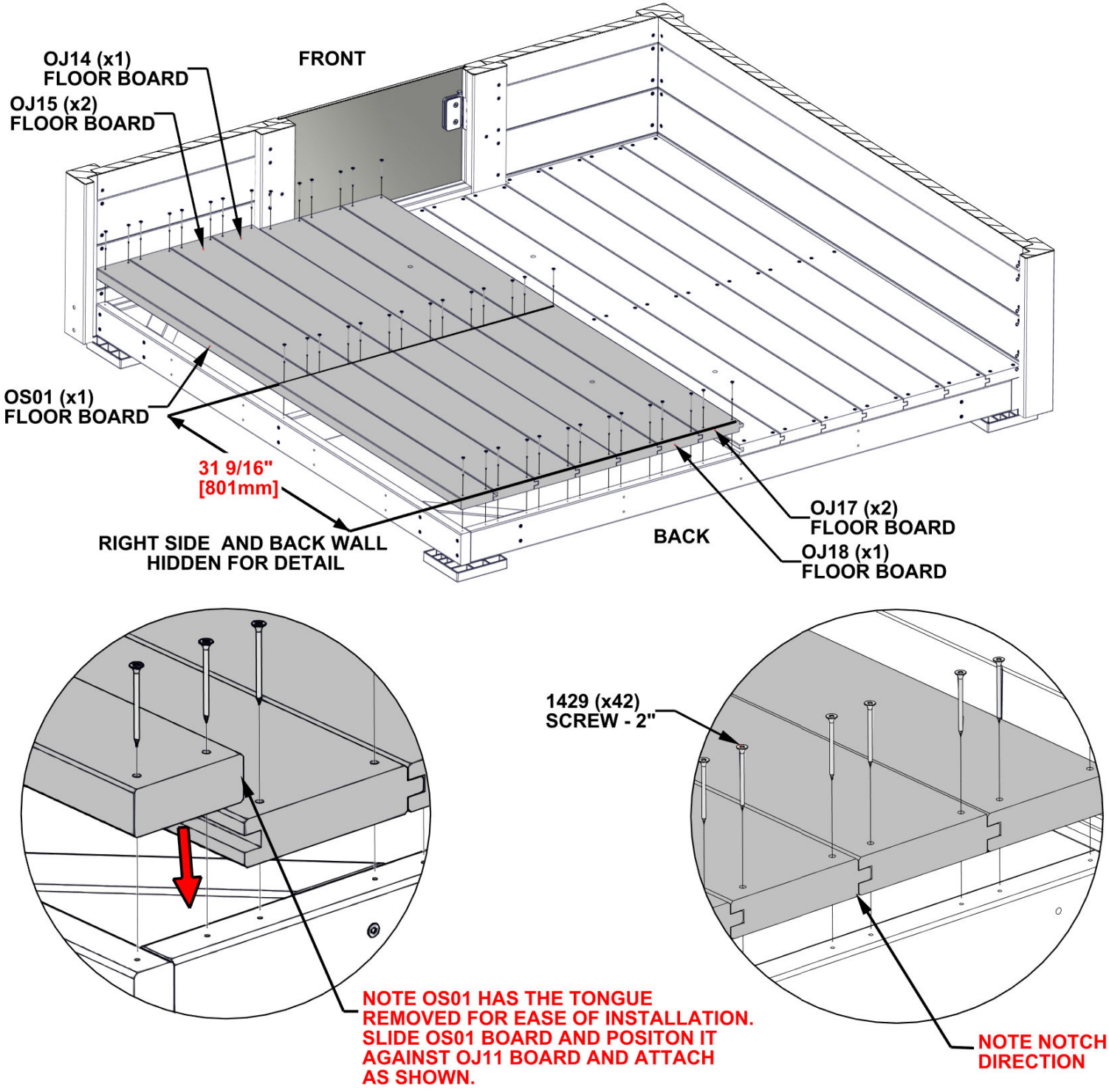

STEP 23 - FLOOR ASSEMBLY

QTY	PART NUMBER	DESCRIPTION
10	H101429	SCREW TFH 8X2 SS-BLK



OO02 FLOOR TRIM - W4L22365
(x1) 1 3/16"x1 3/16"x63 1/16" (30x30x1602)



OO06 FLOOR TRIM - W4L22465
(x1) 1 3/16"x1 3/16"x17 1/4" (30x30x438)

- PRESS FLOOR TRIM AGAINST WALLS AND ATTACH AS SHOWN.

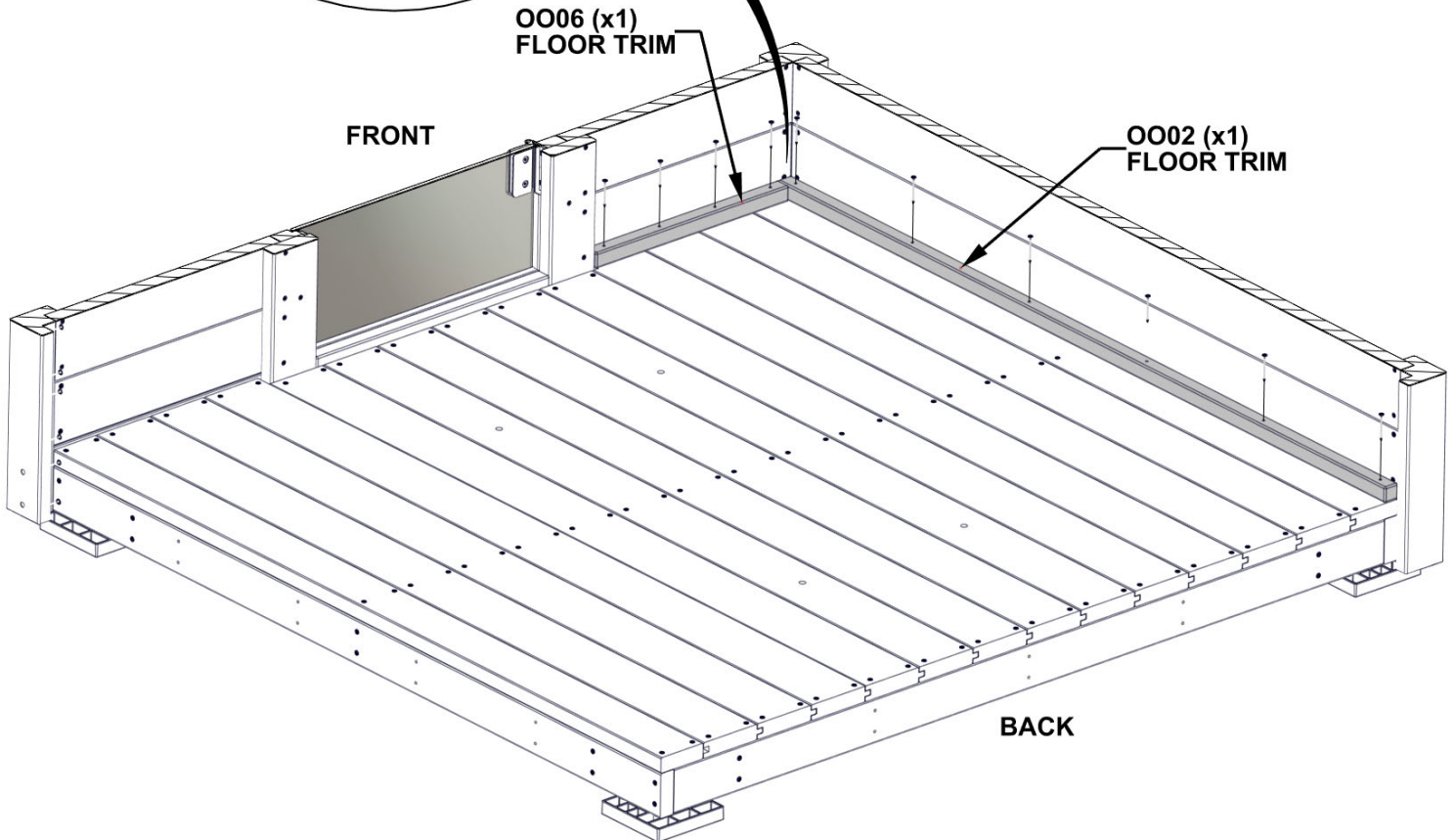
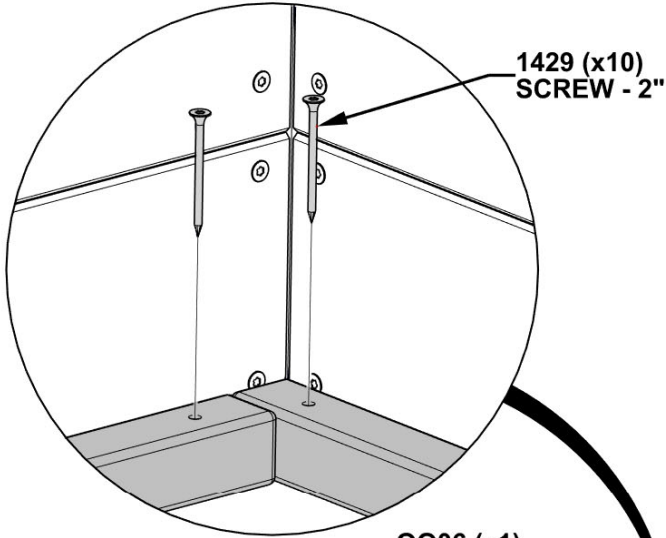

RIGHT SIDE AND BACK WALL
HIDDEN FOR DETAIL

STEP 24 - FLOOR ASSEMBLY

QTY	PART NUMBER	DESCRIPTION
16	H101429	SCREW TFH 8X2 SS-BLK



OO02 FLOOR TRIM - W4L22365
(x1) 1 3/16"x1 3/16"x63 1/16" (30x30x1602)



OO07 FLOOR TRIM - W4L22466
(x1) 1 3/16"x1 3/16"x63 9/16" (30x30x1614)



OO06 FLOOR TRIM - W4L22465
(x1) 1 3/16"x1 3/16"x17 1/4" (30x30x438)

- PRESS FLOOR TRIM AGAINST WALLS AND ATTACH AS SHOWN.

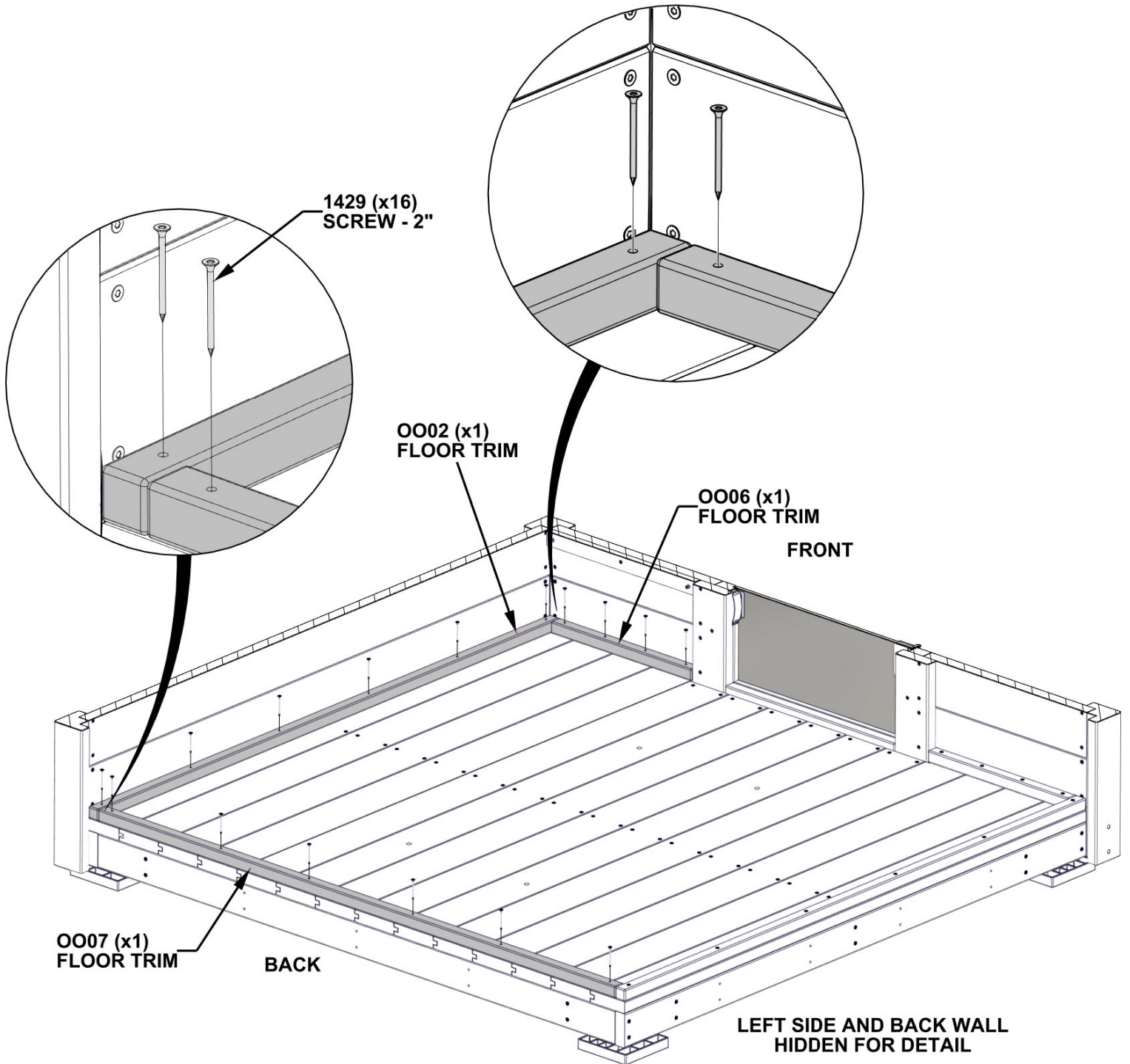

STEP 25 - HANDLE ASSEMBLY

QTY	PART NUMBER	DESCRIPTION
2	H101402	SCREW TFH 1/4-20 X 1 5/8 SS
4	H101403	POLY WASHER

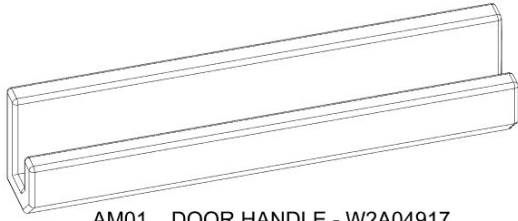

AM01 DOOR HANDLE - W2A04917
(x1) 2 1/4"x3"x13 5/16" (57x76x338)

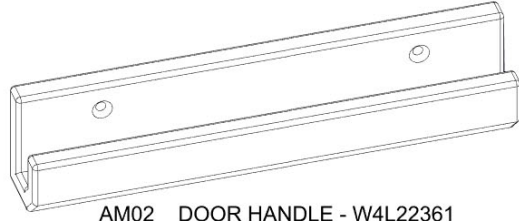

AM02 DOOR HANDLE - W4L22361
(x1) 2 1/4"x3"x13 5/16" (57x76x338)

- ATTACH DOOR HANDLES AS SHOWN.
- DO NOT OVERTIGHTEN.

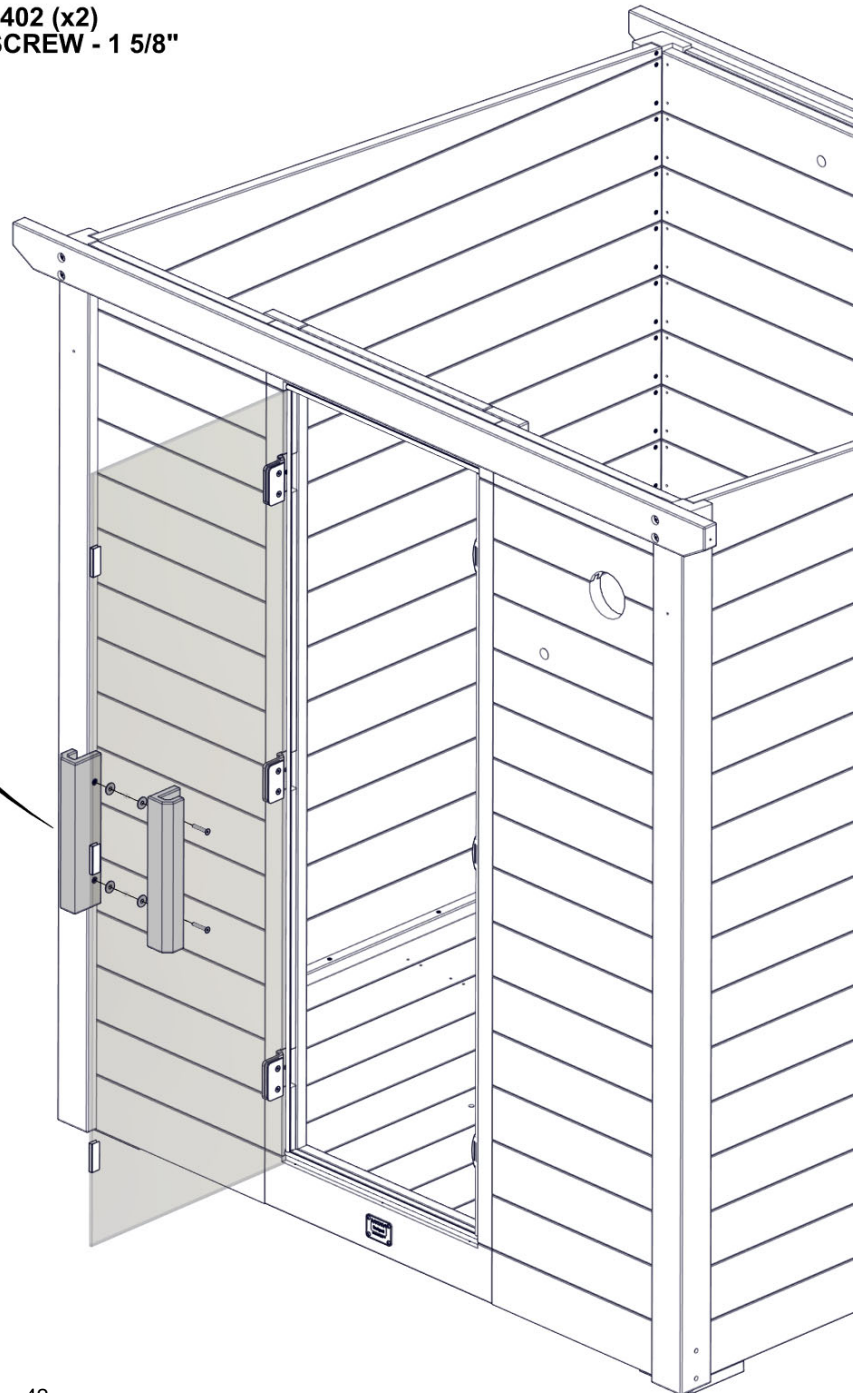
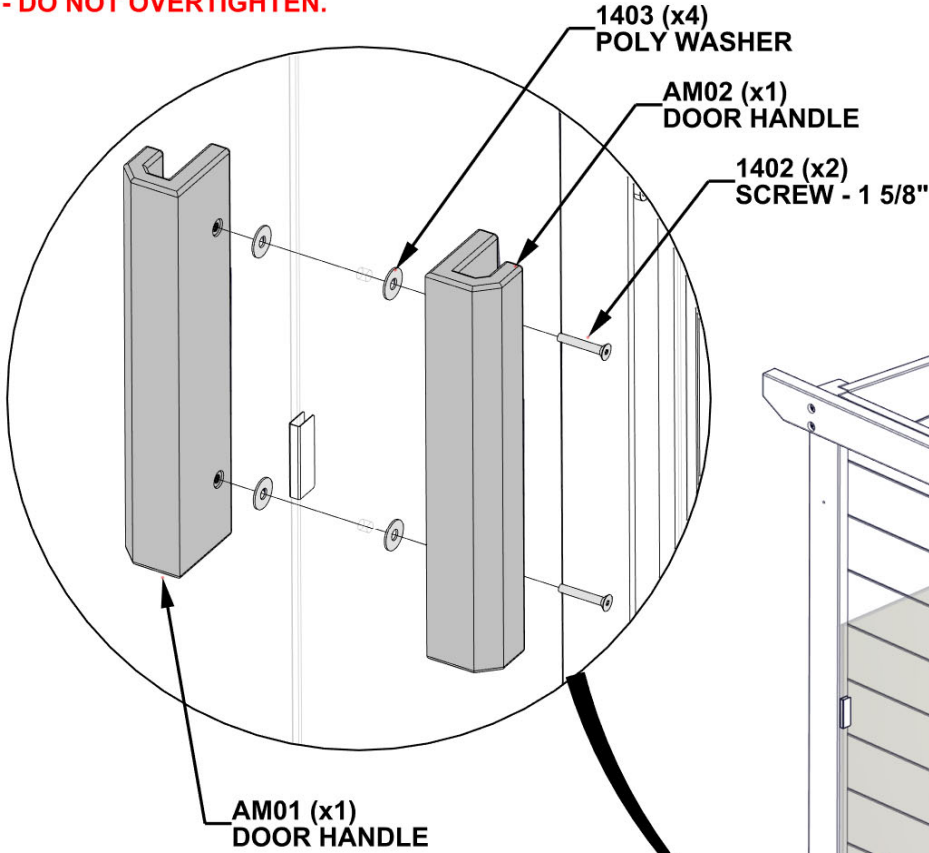

STEP 26 - BENCH ASSEMBLY

QTY	PART NUMBER	DESCRIPTION
6	H101429	SCREW TFH 8X2 SS-BLK

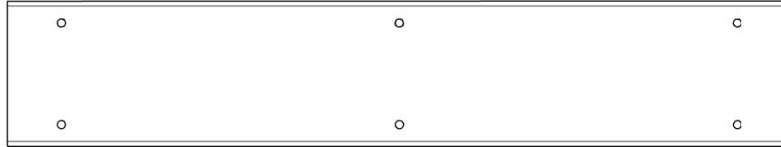

OG16 SEAT CLEAT - W4L22585
(x1) 1 3/16"x3 3/8"x18 1/4" (30x86x464)

- NOTE PILOT HOLES TO BE POSITIONED ON THE TOP SIDE.
- ENSURE OG16 IS LEVEL AND ATTACH AS SHOWN.

**NOTE PILOT HOLES FOR
CORRECT ORIENTATION**

OG16 (x1)
SEAT CLEAT

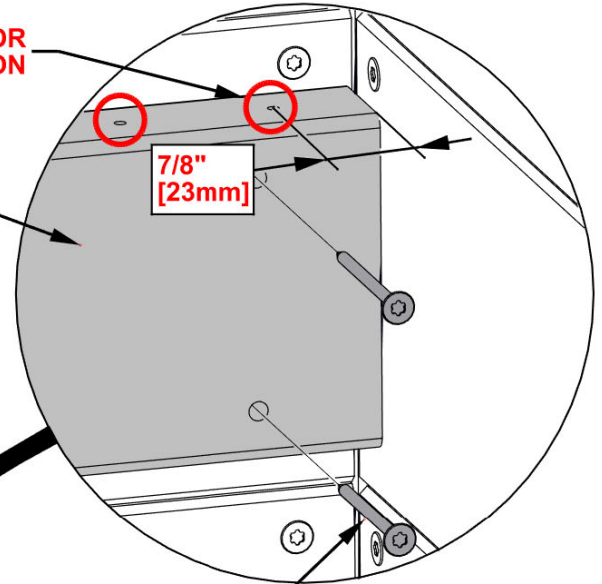

1429 (x6)
SCREW - 2"

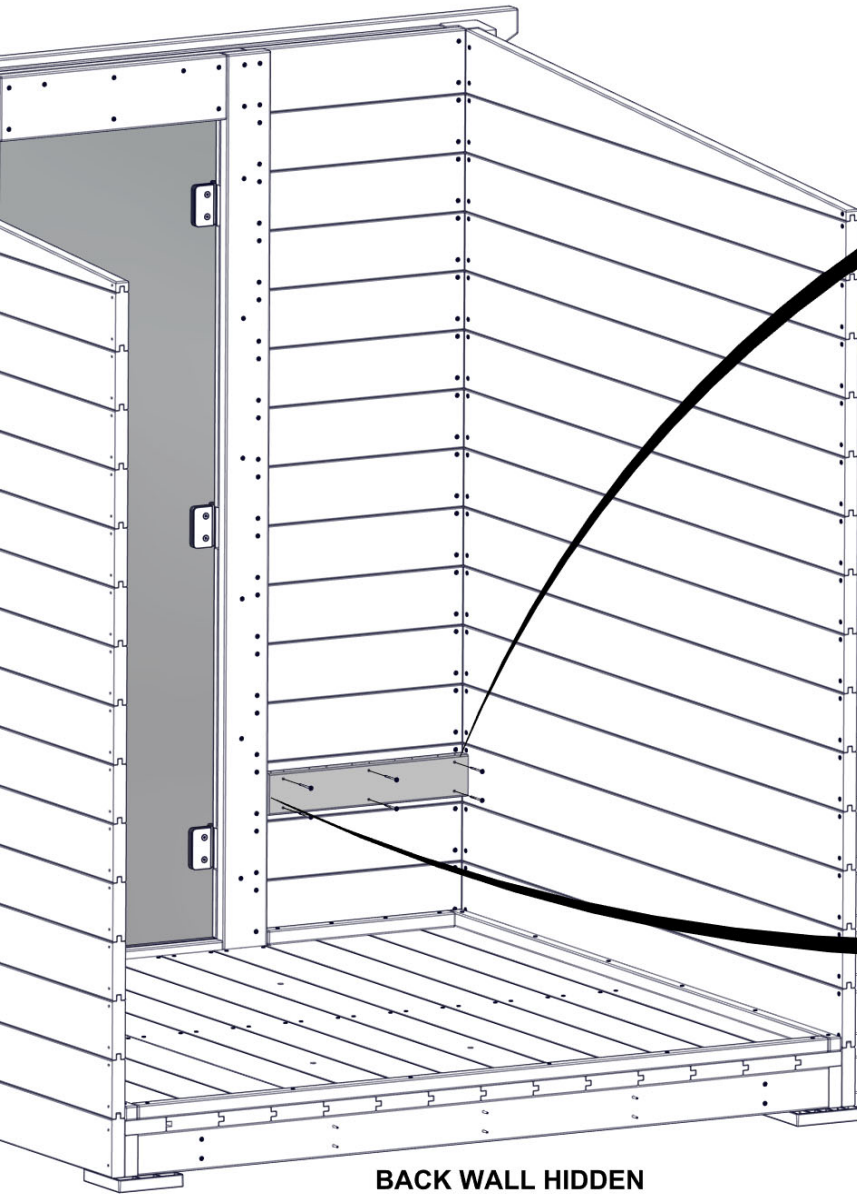

BACK WALL HIDDEN
FOR DETAIL

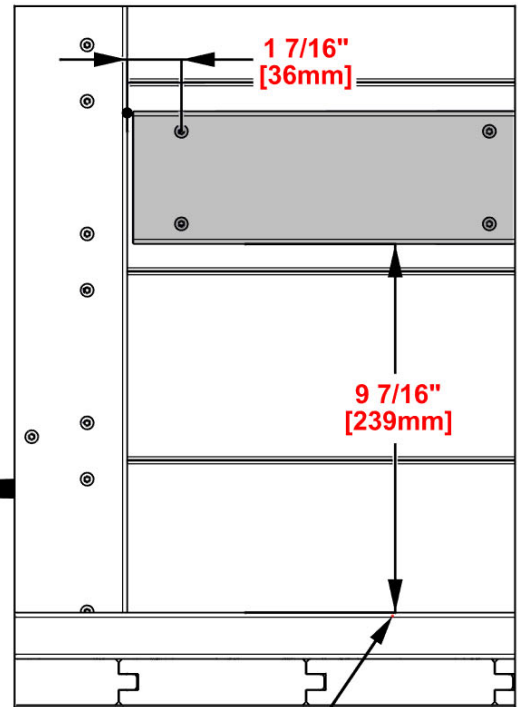

TOP OF
CLEAT

STEP 27 - BENCH ASSEMBLY

QTY	PART NUMBER	DESCRIPTION
17	H101429	SCREW TFH 8X2 SS-BLK

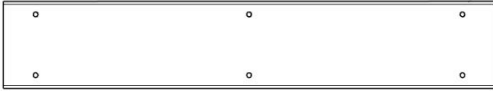

OG08 SEAT CLEAT - W4L22384
(x1) 1 3/16"x3 3/8"x19 1/8" (30x86x486)



OG15 SEAT CLEAT - W4L22407
(x1) 1 3/16"x3 3/8"x19 1/8" (30x86x486)

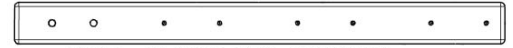

OO01 SLAT CLEAT - W4L22404
(x1) 1 3/16"x1 3/16"x14" (30x30x355)

- NOTE PILOT HOLES TO BE POSITIONED ON THE TOP SIDE.
- FLUSH END OF OG08 AGAINST BACK WALL.
- ENSURE BOARDS ARE LEVEL AND THEN ATTACH AS SHOWN.

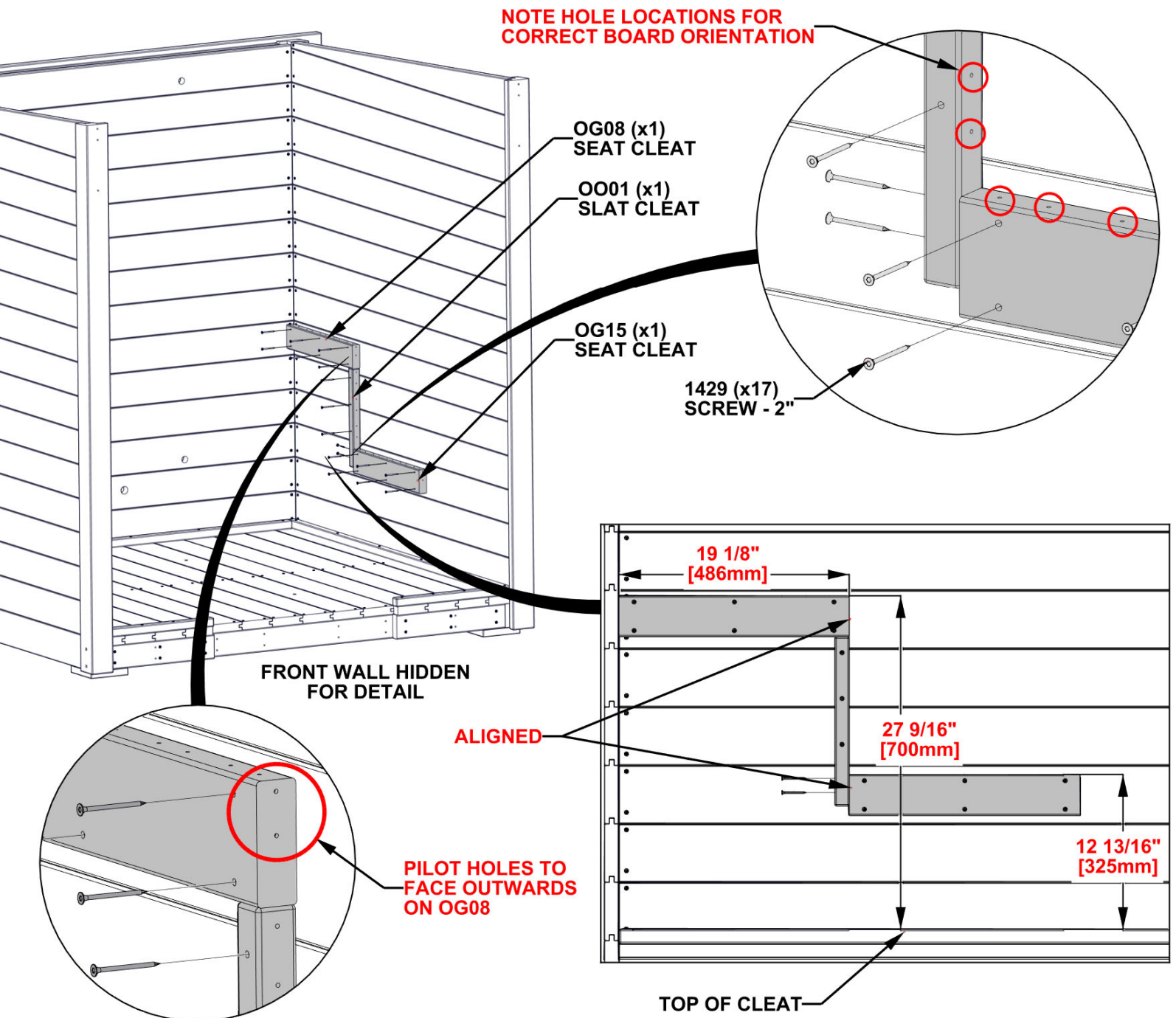

STEP 28 - BENCH ASSEMBLY

QTY	PART NUMBER	DESCRIPTION
17	H101429	SCREW TFH 8X2 SS-BLK

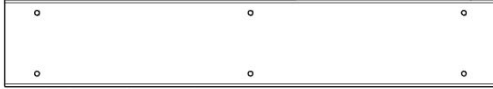

OG08 SEAT CLEAT - W4L22384
(x1) 1 3/16"x3 3/8"x19 1/8" (30x86x486)



OG15 SEAT CLEAT - W4L22407
(x1) 1 3/16"x3 3/8"x19 1/8" (30x86x486)



OO01 SLAT CLEAT - W4L22404
(x1) 1 3/16"x1 3/16"x14" (30x30x355)

- NOTE PILOT HOLES TO BE POSITIONED ON THE TOP SIDE.
- FLUSH END OF OG08 AGAINST BACK WALL.
- ENSURE BOARDS ARE LEVEL AND THEN ATTACH AS SHOWN.

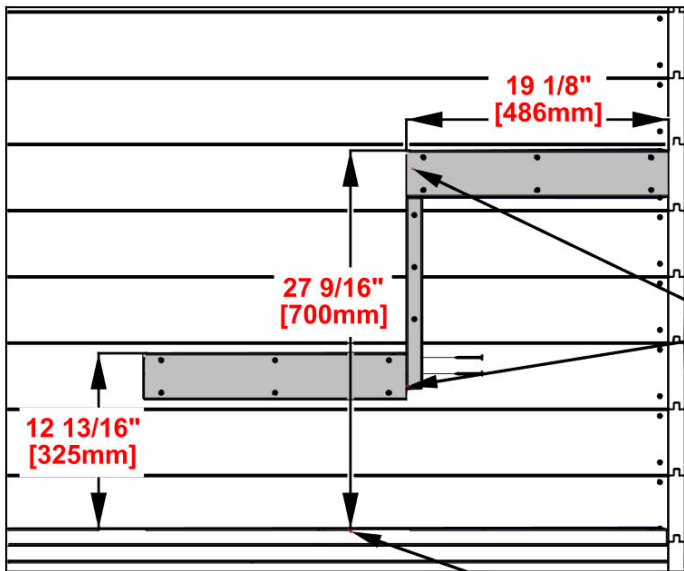
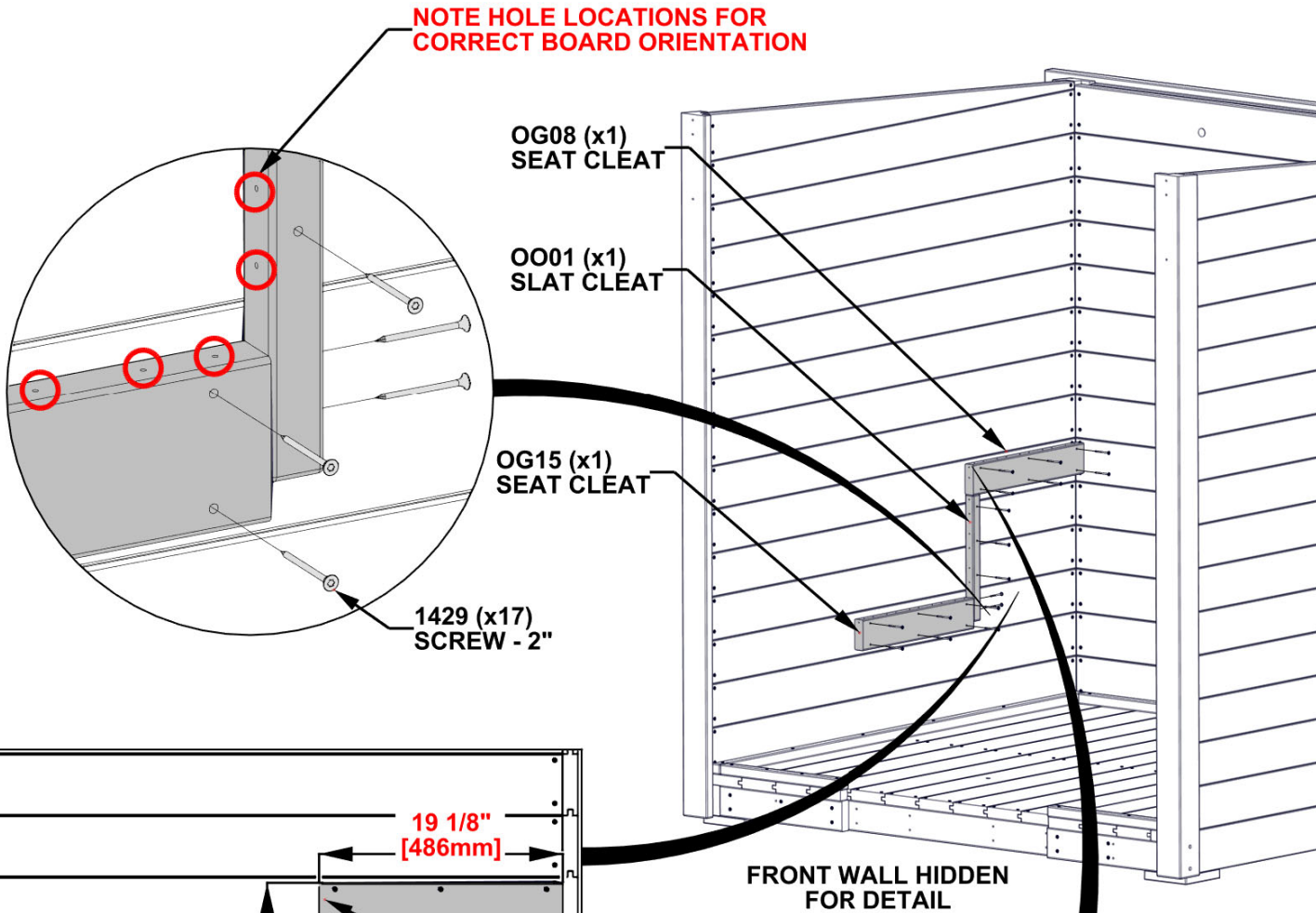

ALIGNED

PILOT HOLES TO FACE OUTWARDS ON OG08

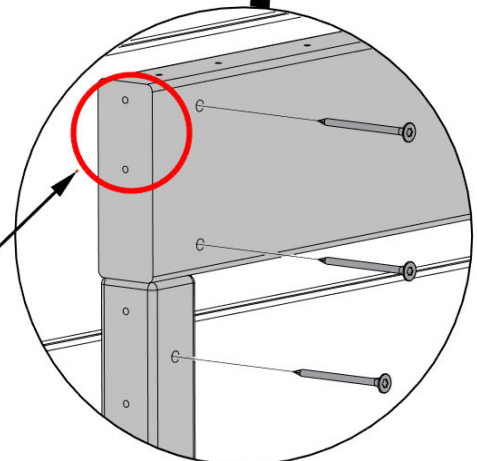

STEP 29 - BENCH ASSEMBLY

QTY	PART NUMBER	DESCRIPTION
12	H101429	SCREW TFH 8X2 SS-BLK



OG02 SEAT CLEAT - W4L21943
(x1) 1 3/16"x3 3/8"x60 15/16" (30x86x1548)

- CLEAT SHOULD BE CENTERED ON THE BACK WALL.
- ENSURE TOP OF SEAT CLEAT ARE FLUSH WITH CLEATS ON SIDE WALLS.
- USE DIMENSIONS SHOWN TO LOCATE WALL CLEAT.
- MEASUREMENT SHOWN IS TAKEN FROM INSIDE THE WALL.
- ATTACH AS SHOWN.

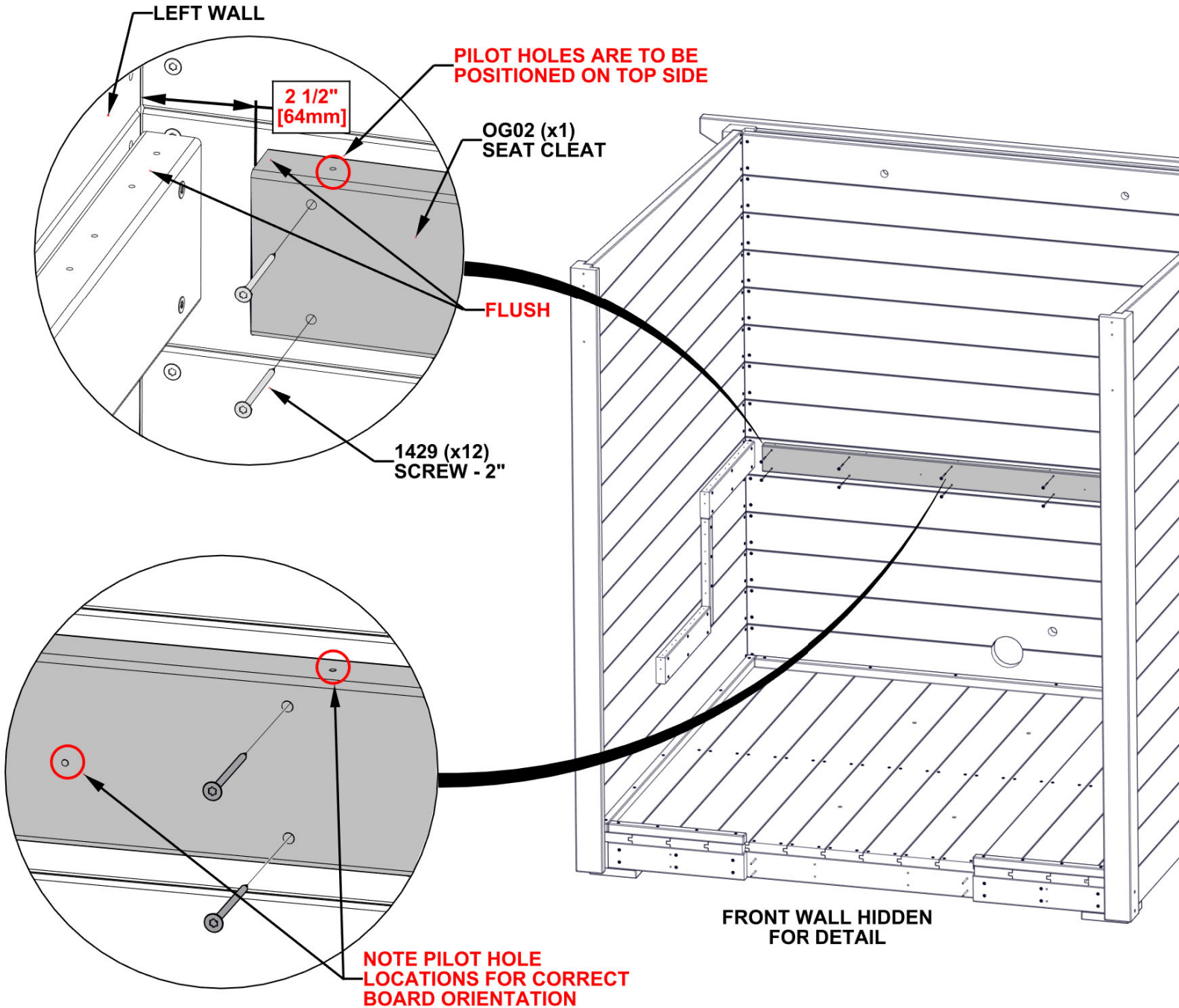

STEP 30 - ELECTRICAL

QTY	PART NUMBER	DESCRIPTION
2	H101409	SCREW PPH 4x1/2 BLK

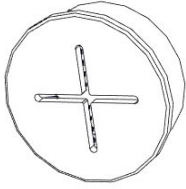

A6P01468 30mm SILCONE GROMMET (x1)



A6P01543 SAUNA POWER WIRE (x1)

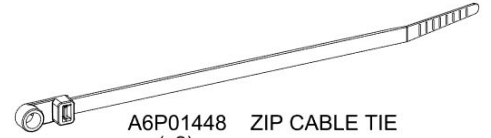

A6P01448 ZIP CABLE TIE (x2)

- USE PROVIDED GROMMET FOR POWER WIRE.
- WILL NEED TO REMOVE CONDUIT FITTING TO FEED SAUNA POWER WIRE THROUGH GROMMET.
- RUN POWER WIRE AS SHOWN IN DETAIL BELOW.
- NOTE A LICENSE ELECTRICIAN IS REQUIRED FOR HEATER INSTALLATION.

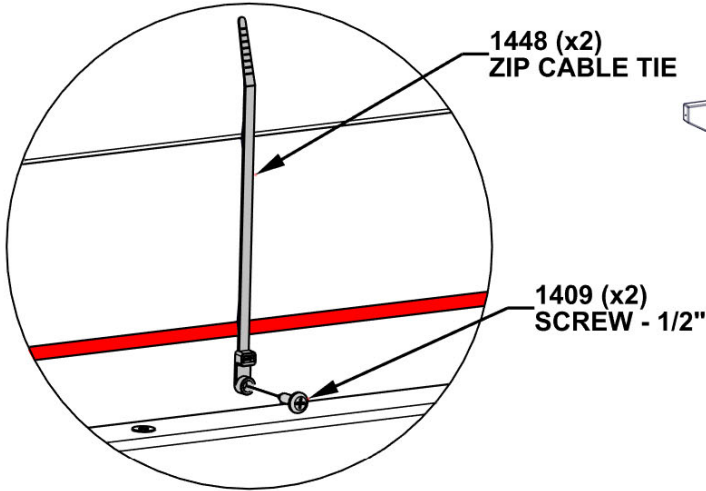

RUN SAUNA POWER WIRE ALONG WALL. ATTACH WITH PROVIDED ZIP TIES AS SHOWN, LEAVING APPROXIMATELY 18" [457mm] FROM THE SIDEWALL FOR HEATER.

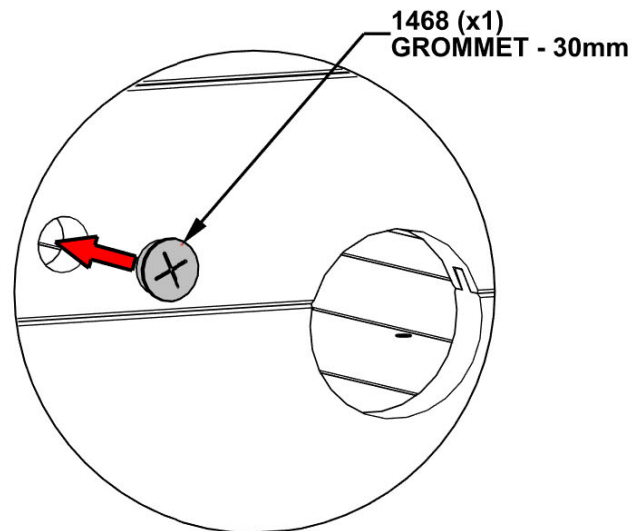
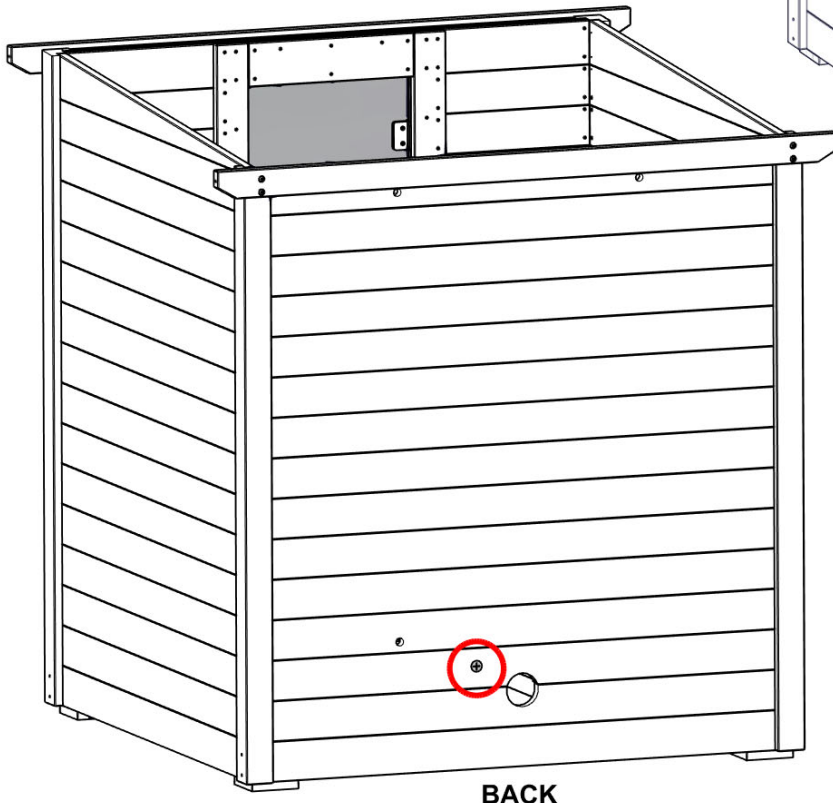
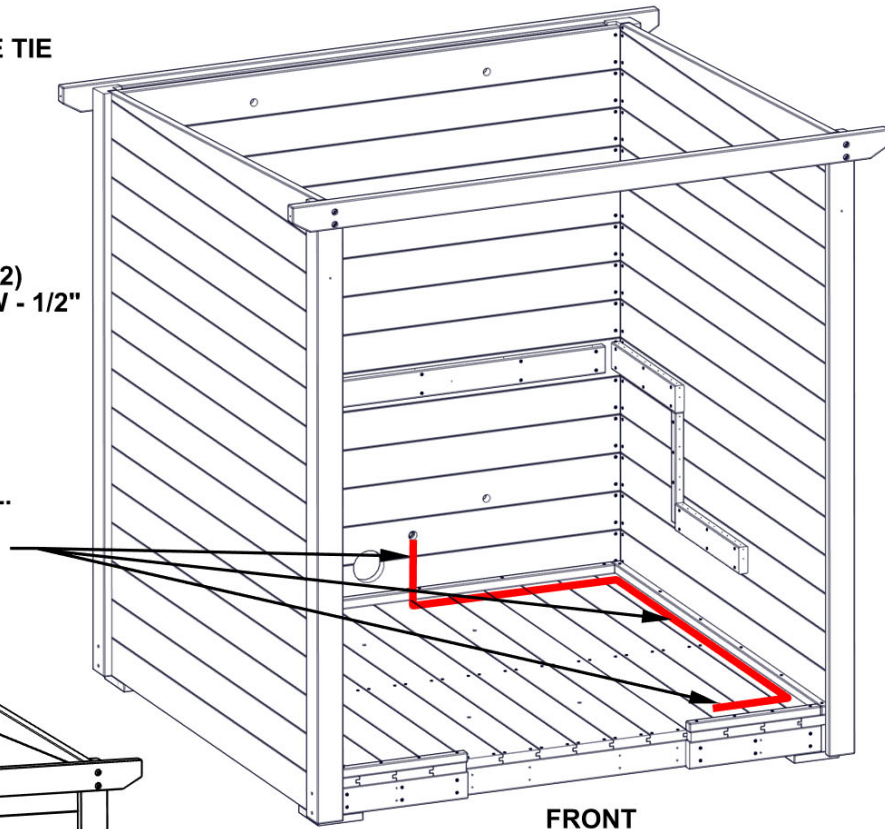

STEP 31 - BENCH ASSEMBLY

QTY	PART NUMBER	DESCRIPTION
4	H101431	SCREW TFH 8X2 1/2 SS-BLK
8	H101443	SCREW TWH 8x1 1/2 SS-BLK

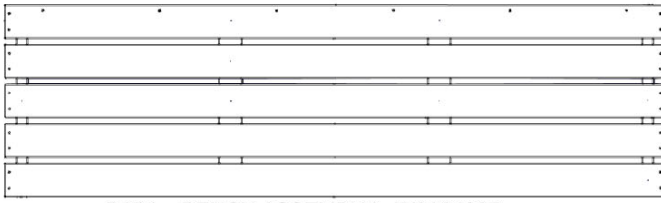

BA01 BENCH ASSEMBLY - W2A04927
(x1) 1 15/16"x19 1/8"x65 3/4" (50x486x1670)



OR01 SEAT UPRIGHT - W4L22406
(x2) 1 3/16"x2 3/8"x28 3/4" (30x60x730)



OR02 ANGLE BRACE - W4L21946
(x2) 1 3/16"x2 3/8"x10 7/8" (30x60x276)

- ALIGN PILOT HOLES AND ATTACH SEAT UPRIGHT TO BENCH ASSEMBLY AS SHOWN.
- THEN ALIGN PILOT HOLES IN ANGLE BRACE WITH PILOT HOLES IN SEAT UPRIGHT AND BENCH ASSEMBLY AND ATTACH.

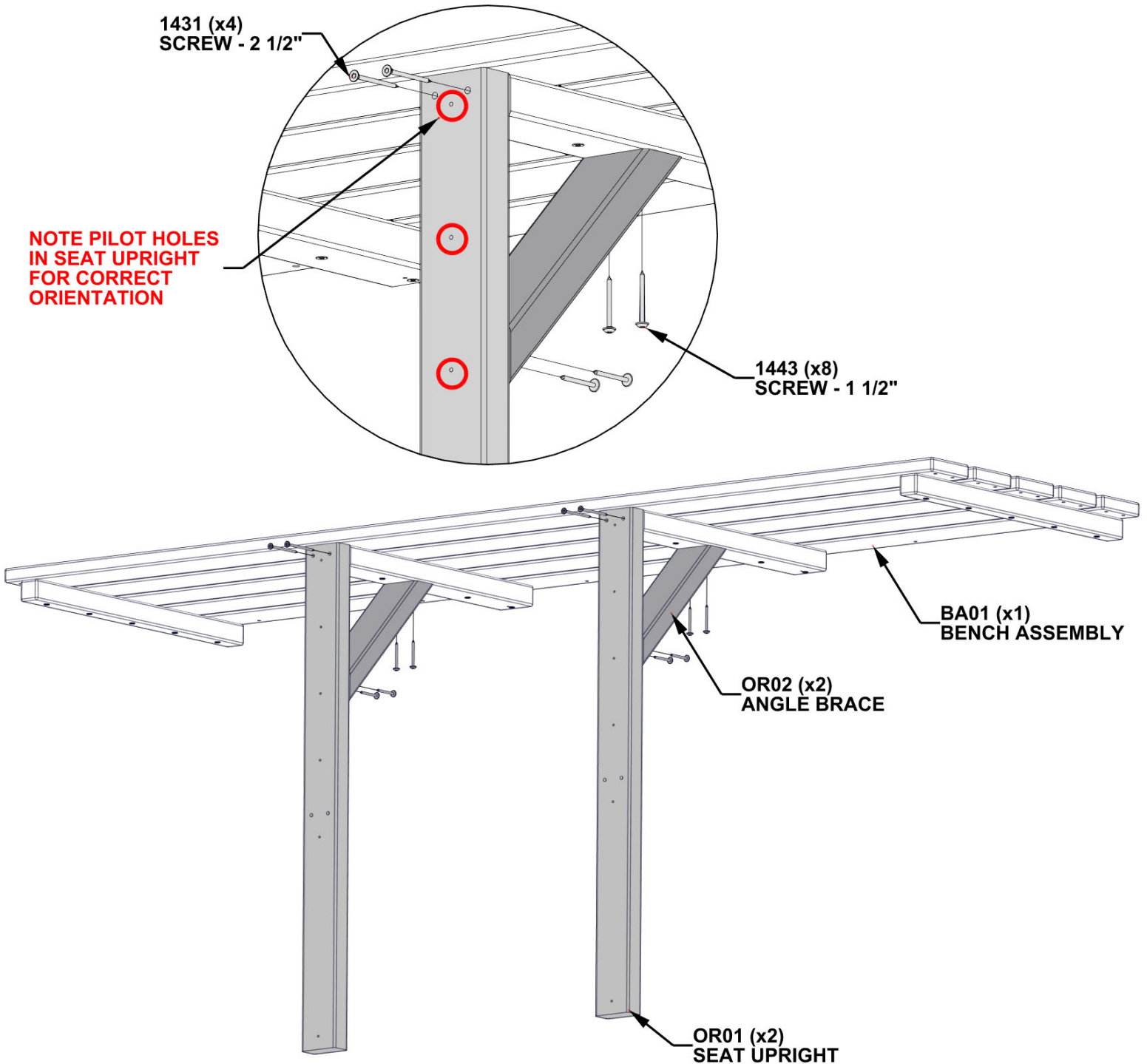

STEP 32 - BENCH ASSEMBLY

QTY	PART NUMBER	DESCRIPTION
26	H101428	SCREW TFH 8X1 3/4 SS-BLK

- ALIGN THROUGH HOLES IN BENCH ASSEMBLY WITH PILOT HOLES IN SEAT CLEATS AND ATTACH AS SHOWN.

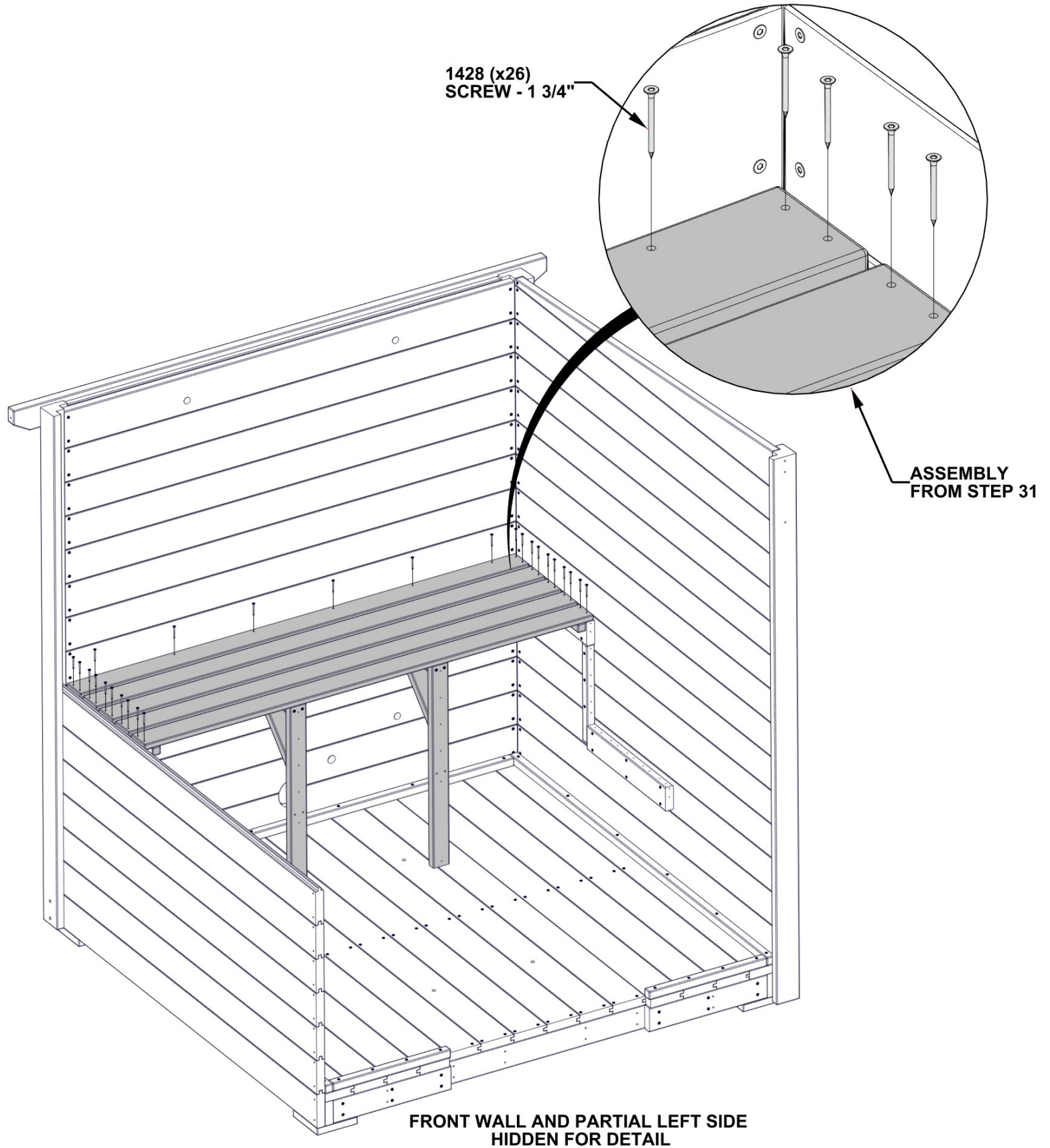

STEP 33 - BENCH ASSEMBLY

QTY	PART NUMBER	DESCRIPTION
8	H101438	SCREW TWH 8x3/4 SS-BLK

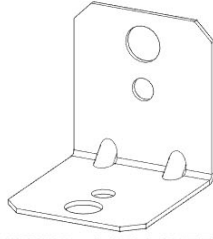

A4M00555 L BRACKET BLK
(x4)

- ALIGN UPPER BRACKET THROUGH HOLES WITH PILOT HOLES IN WALL CLEAT AND ATTACH AS SHOWN.
- AFTER ATTACHING TO WALL CLEAT, SQUARE AND LEVEL LEGS AND ATTACH TO FLOOR AS SHOWN.

555 (x4)
L BRACKET BLK

ALIGN WITH
PILOT HOLES

1438 (x8)
SCREW - 3/4"

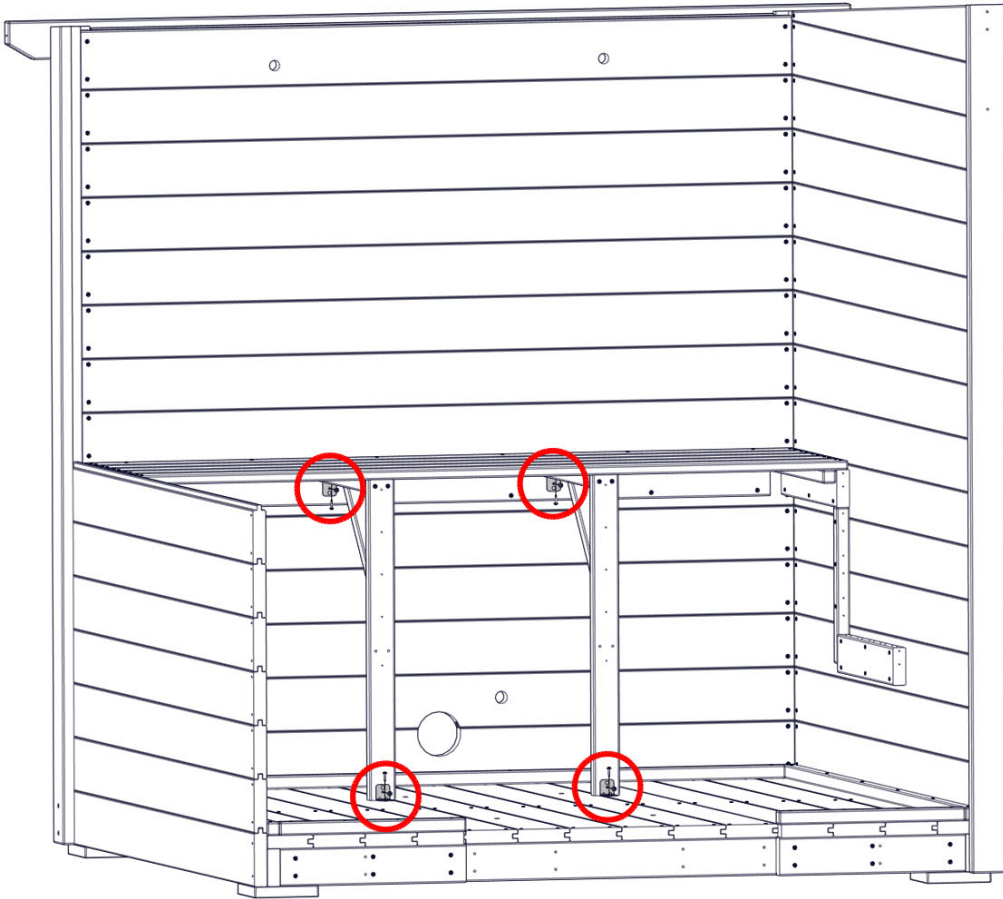
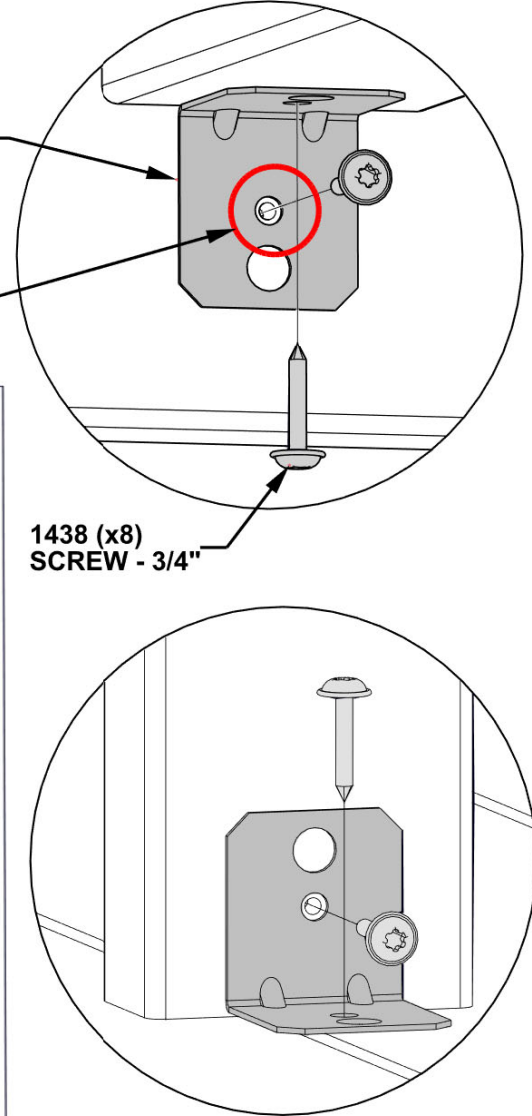

FRONT WALL AND PARTIAL LEFT SIDE
HIDDEN FOR DETAIL

STEP 34 - BENCH ASSEMBLY

QTY	PART NUMBER	DESCRIPTION
4	H101431	SCREW TFH 8X2 1/2 SS-BLK
8	H101443	SCREW TWH 8x1 1/2 SS-BLK

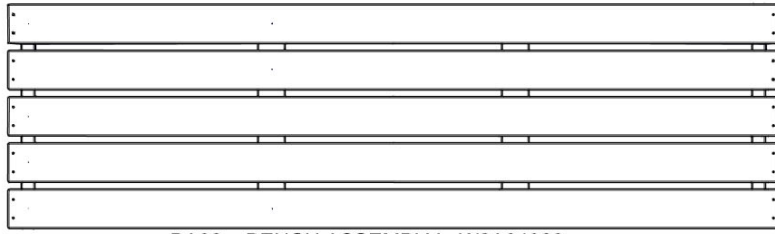

BA02 BENCH ASSEMBLY - W2A04928
(x1) 1 15/16"x19 1/8"x65 3/4" (50x486x1670)



OR03 BENCH UPRIGHT - W4L22405
(x2) 1 3/16"x2 3/8"x14" (30x60x355)



OR02 ANGLE BRACE - W4L21946
(x2) 1 3/16"x2 3/8"x10 7/8" (30x60x276)

- ALIGN PILOT HOLES AND ATTACH SEAT UPRIGHT TO BENCH ASSEMBLY AS SHOWN.
- THEN ALIGN PILOT HOLES IN ANGLE BRACE WITH PILOT HOLES IN SEAT UPRIGHT AND BENCH ASSEMBLY AND ATTACH.

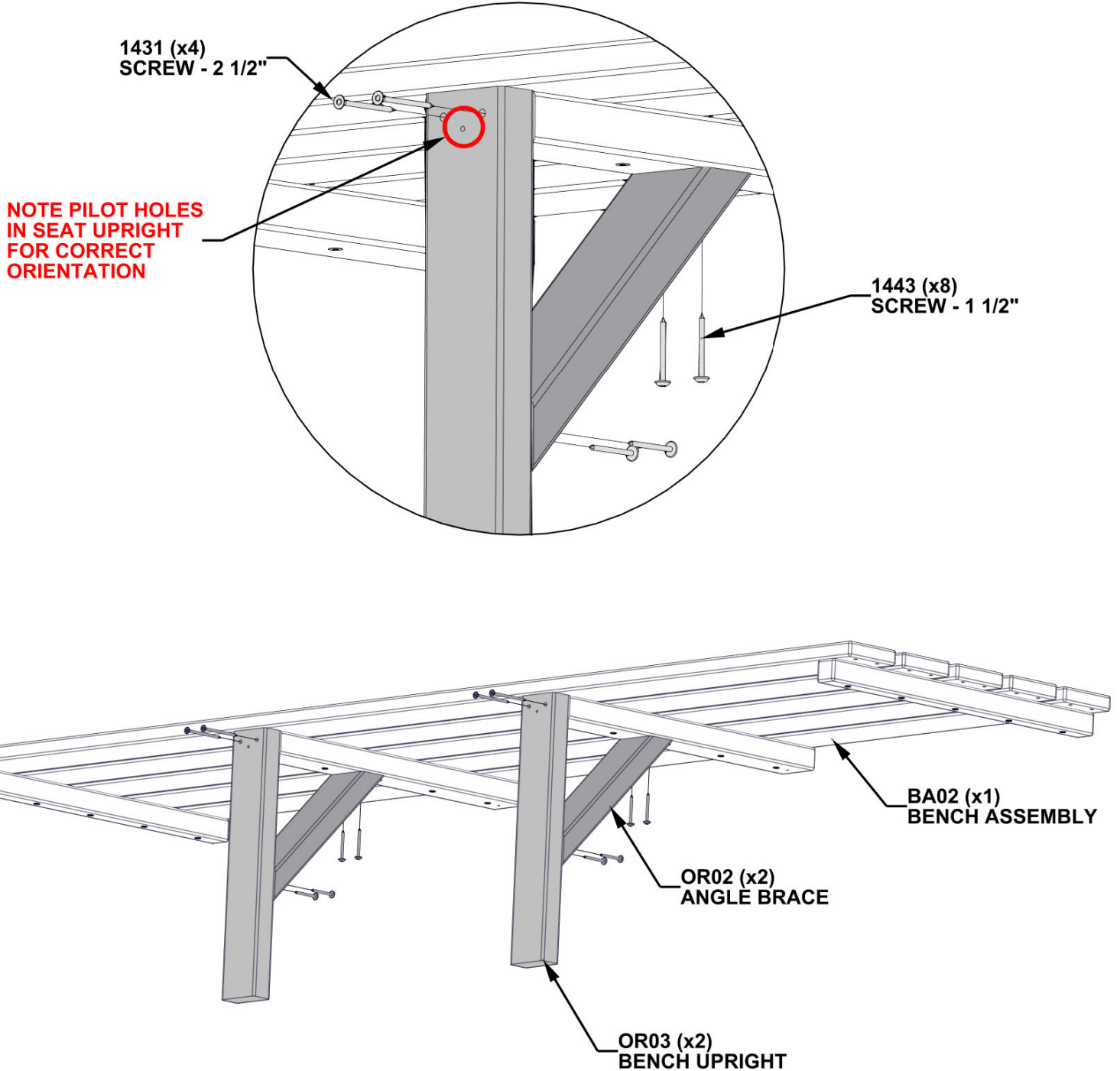

STEP 35 - BENCH ASSEMBLY

QTY	PART NUMBER	DESCRIPTION
20	H101428	SCREW TFH 8X1 3/4 SS-BLK
4	H101431	SCREW TFH 8X2 1/2 SS-BLK

- ALIGN THROUGH HOLES IN BENCH ASSEMBLY WITH PILOT HOLES IN SEAT CLEATS AND ATTACH AS SHOWN.
- ALIGN THROUGH HOLES IN PREVIOUSLY INSTALLED BENCH UPRIGHTS WITH PILOT HOLES IN BENCH ASSEMBLY.

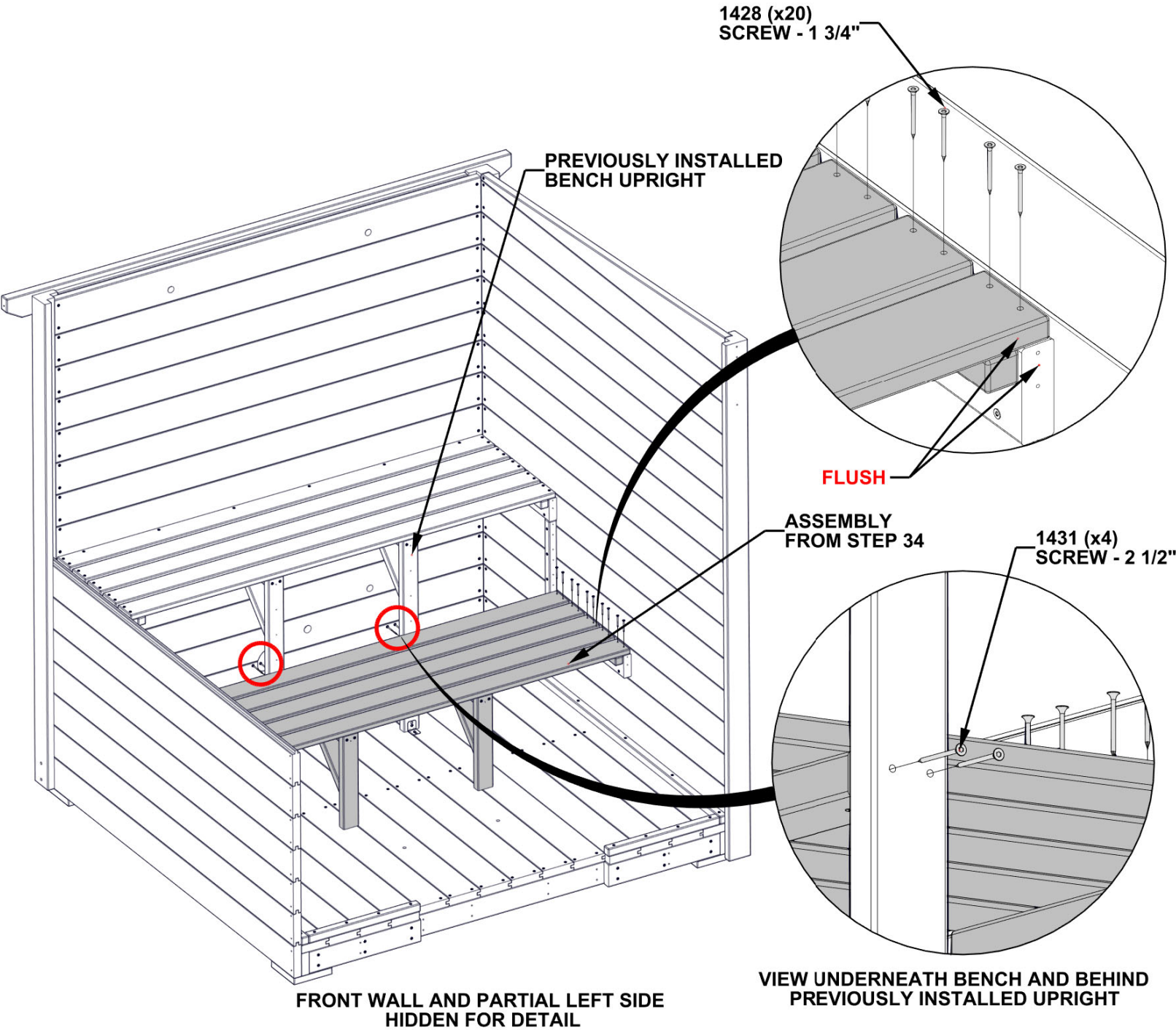

STEP 36 - BENCH ASSEMBLY

QTY	PART NUMBER	DESCRIPTION
8	H101438	SCREW TWH 8x3/4 SS-BLK

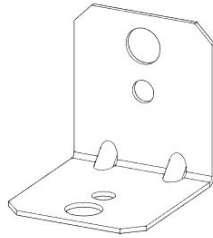

A4M00555 L BRACKET BLK
(x4)

- ALIGN BRACKETS WITH PILOT HOLES IN BACKS OF UPRIGHTS AND ATTACH AS SHOWN.

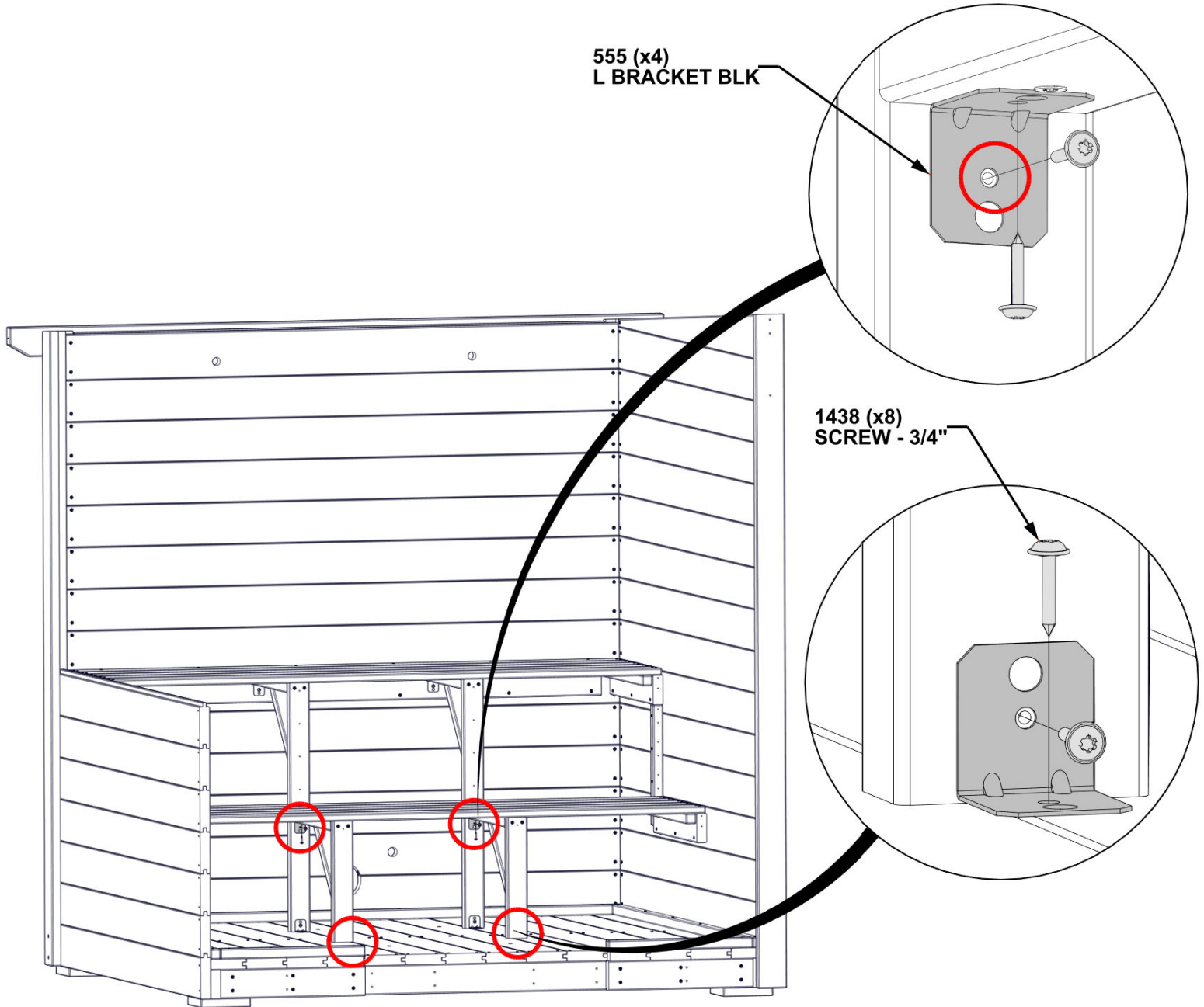

STEP 37 - BENCH ASSEMBLY

QTY	PART NUMBER	DESCRIPTION
12	H101430	SCREW TFH 8X2 1/4 SS-BLK



W01 SEAT TRIM - W4L21948
(x1) 1 9/16"x3 3/8"x65 3/4" (40x86x1670)



W04 SEAT TRIM - W4L22586
(x1) 1 9/16"x3 3/8"x65 3/4" (40x86x1670)

- ALIGN THROUGH HOLES IN SEAT TRIM WITH PILOT HOLES IN UPRIGHTS AND CLEATS AND ATTACH

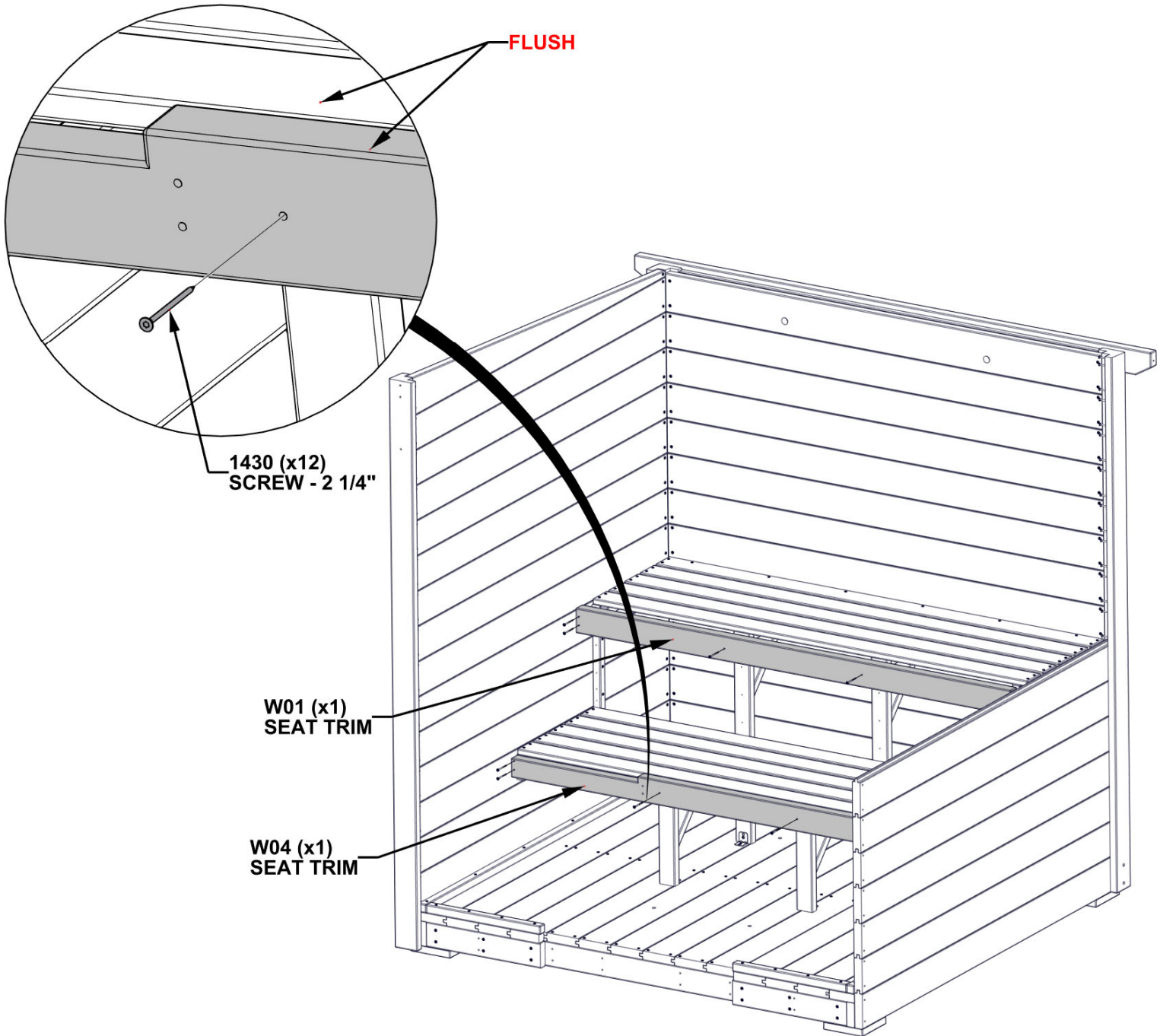

STEP 38 - BENCH ASSEMBLY

QTY	PART NUMBER	DESCRIPTION
20	H101428	SCREW TFH 8X1 3/4 SS-BLK



BA03 BENCH ASSEMBLY - W2A04983
(x1) 1 15/16"x19 1/8"x24 13/16" (50x486x630)

- FLUSH BENCH AGAINST BOTH FRONT AND LEFT SIDE WALL.
- POSITION BENCH INTO NOTCH PROVIDED ON LOWER BENCH ASSEMBLY.

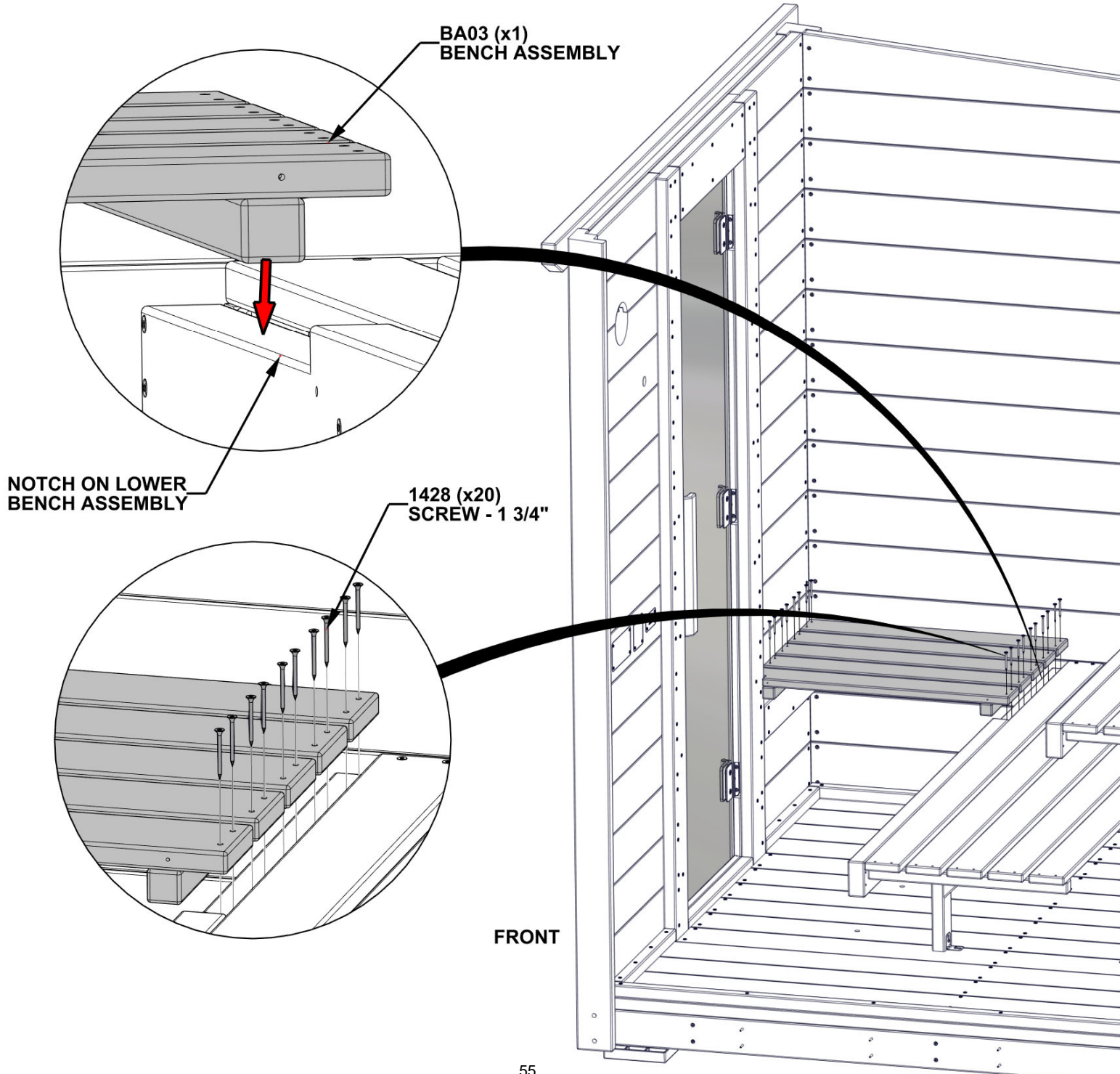

FRONT

STEP 39 - BENCH ASSEMBLY

QTY	PART NUMBER	DESCRIPTION
2	H101430	SCREW TFH 8X2 1/4 SS-BLK



W05 SEAT TRIM - W4L22587
(x1) 1 9/16"x3 3/8"x22 1/16" (40x86x560)

- ALIGN THROUGH HOLES IN SEAT TRIM WITH PILOT HOLES ON BENCH ASSEMBLY AND ATTACH AS SHOWN.

**NOTE THE SIDE WITH
TWO PILOT HOLES
FOR CORRECT
ORIENTATION**

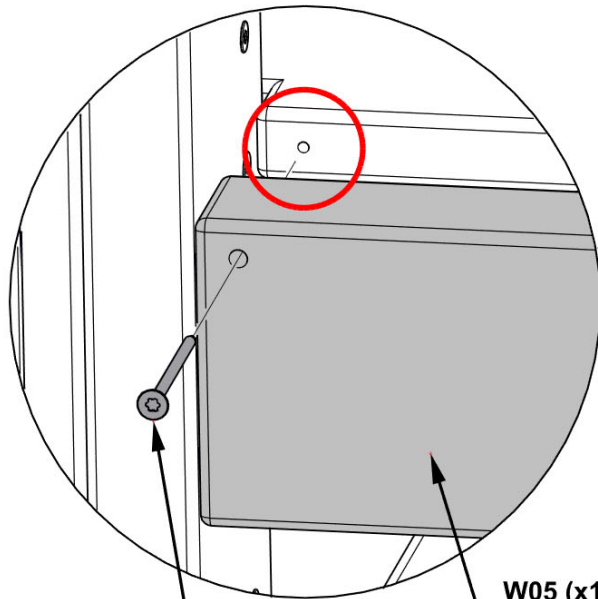
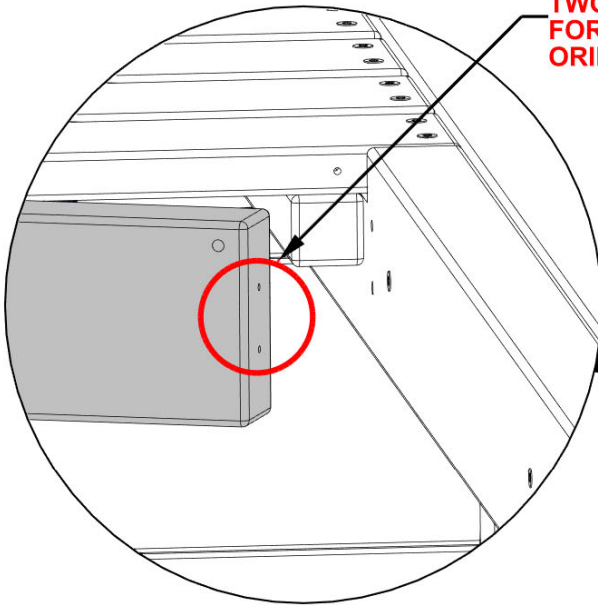

1430 (x2)
SCREW - 2 1/4"

W05 (x1)
SEAT TRIM

FRONT

STEP 40 - BENCH ASSEMBLY

QTY	PART NUMBER	DESCRIPTION
2	H101431	SCREW TFH 8X2 1/2 SS-BLK
2	H101438	SCREW TWH 8x3/4 SS-BLK

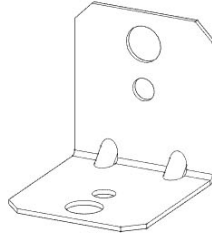

A4M00555 L BRACKET BLK
(x1)

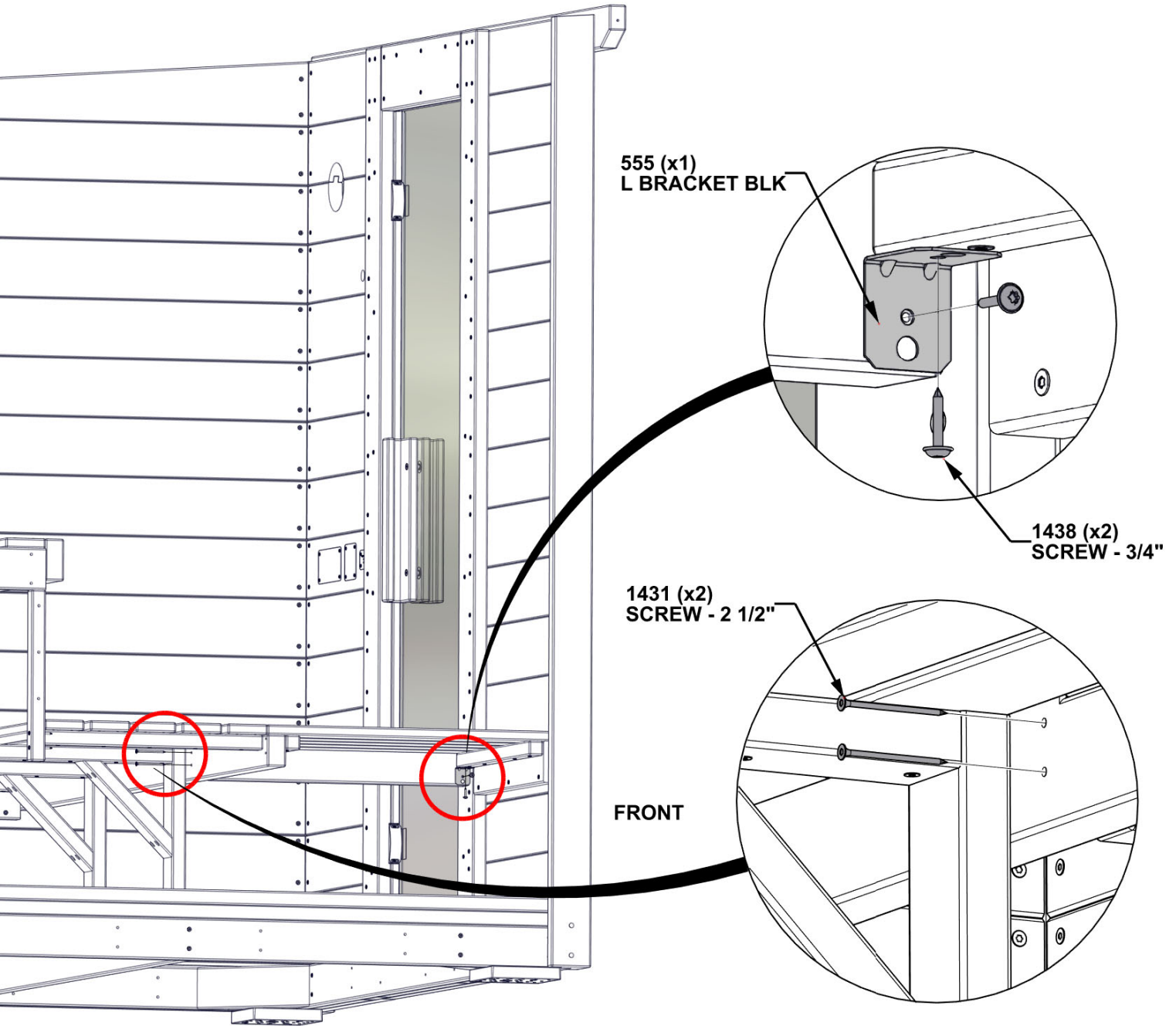

LEFT SIDE WALL
HIDDEN FOR DETAIL

STEP 41 - HEATER ASSEMBLY

QTY	PART NUMBER	DESCRIPTION
8	H101427	SCREW TFH 8X1 1/2 SS-BLK

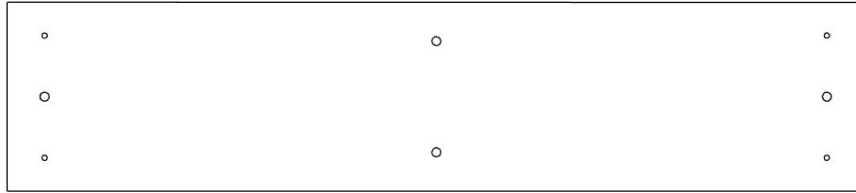

Y01 HEATER SPACER BOARD - W4L22601
(x2) 5/8"x4"x18 1/4" (16x102x464)

- FLUSH Y01 BOARD AGAINST DOOR FRAME.
- USE DIMENSIONS SHOWN TO LOCATE HEATER SPACER BOARDS AND ATTACH AS SHOWN.

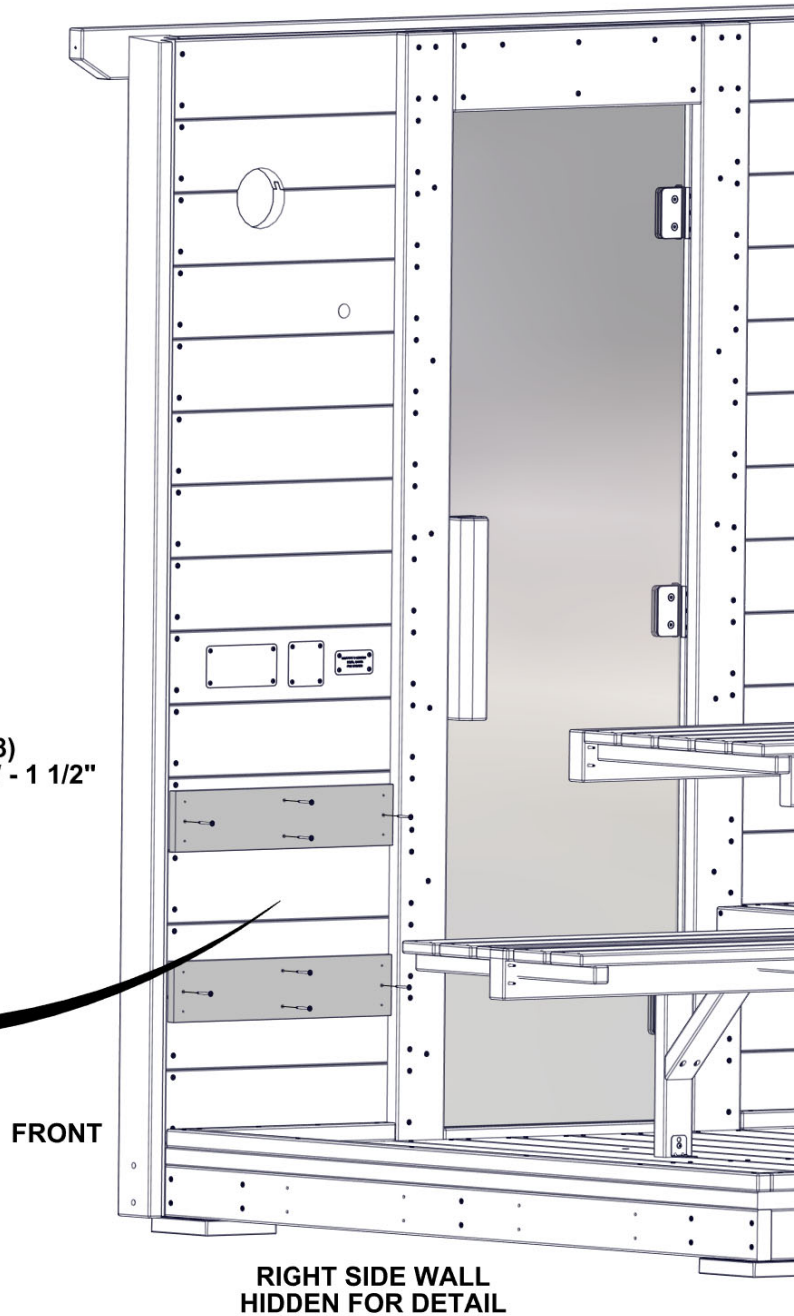
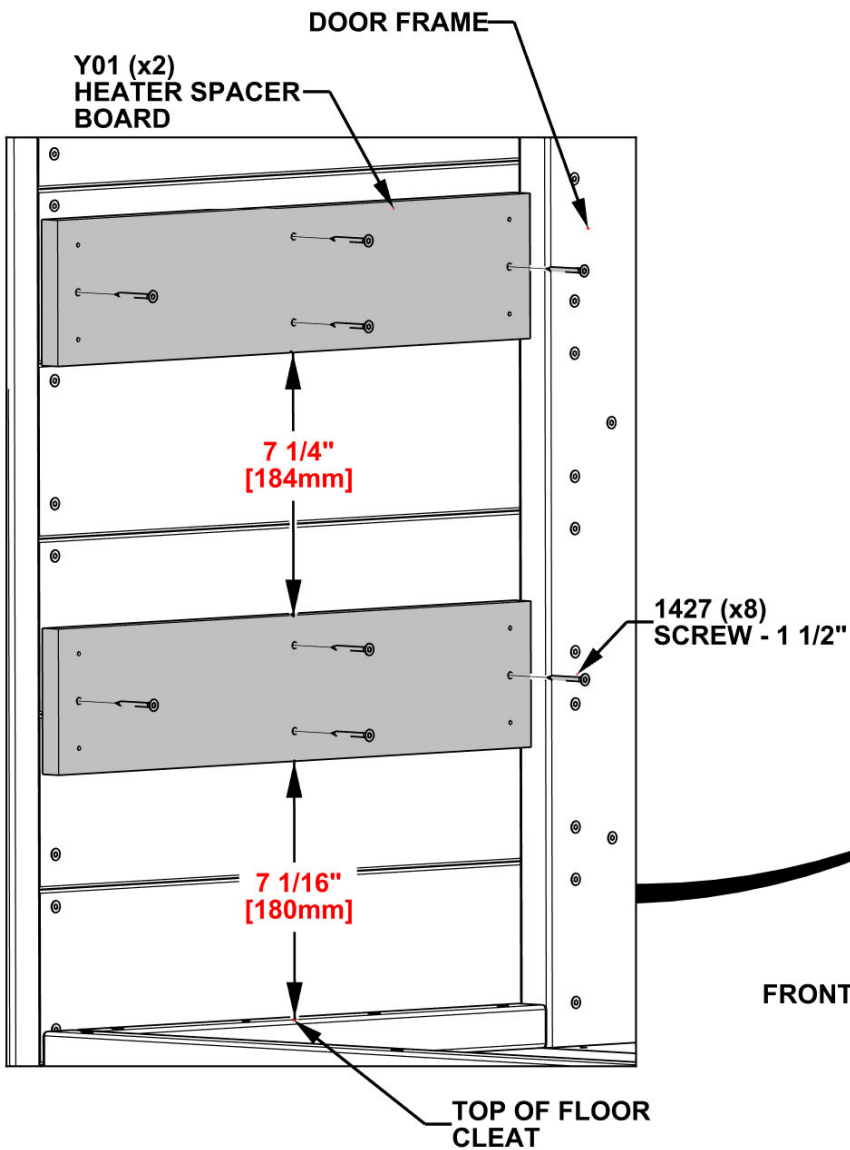

STEP 42 - HEATER GUARD

QTY	PART NUMBER	DESCRIPTION
15	H101428	SCREW TFH 8X1 3/4 SS-BLK



NR04 HEATER GUARD BOARD - W4L22037
(x5) 13/16"x2 3/8"x15 11/16" (20x60x398)



OO03 HEATER GUARD BOARD - W4L22038
(x1) 1 3/16"x1 3/16"x16 1/8" (30x30x410)



OO04 HEATER GUARD BOARD - W4L22035
(x1) 1 3/16"x1 3/16"x16 1/8" (30x30x410)

- ALIGN THROUGH HOLES WITH PILOT HOLES AND ATTACH AS SHOWN.

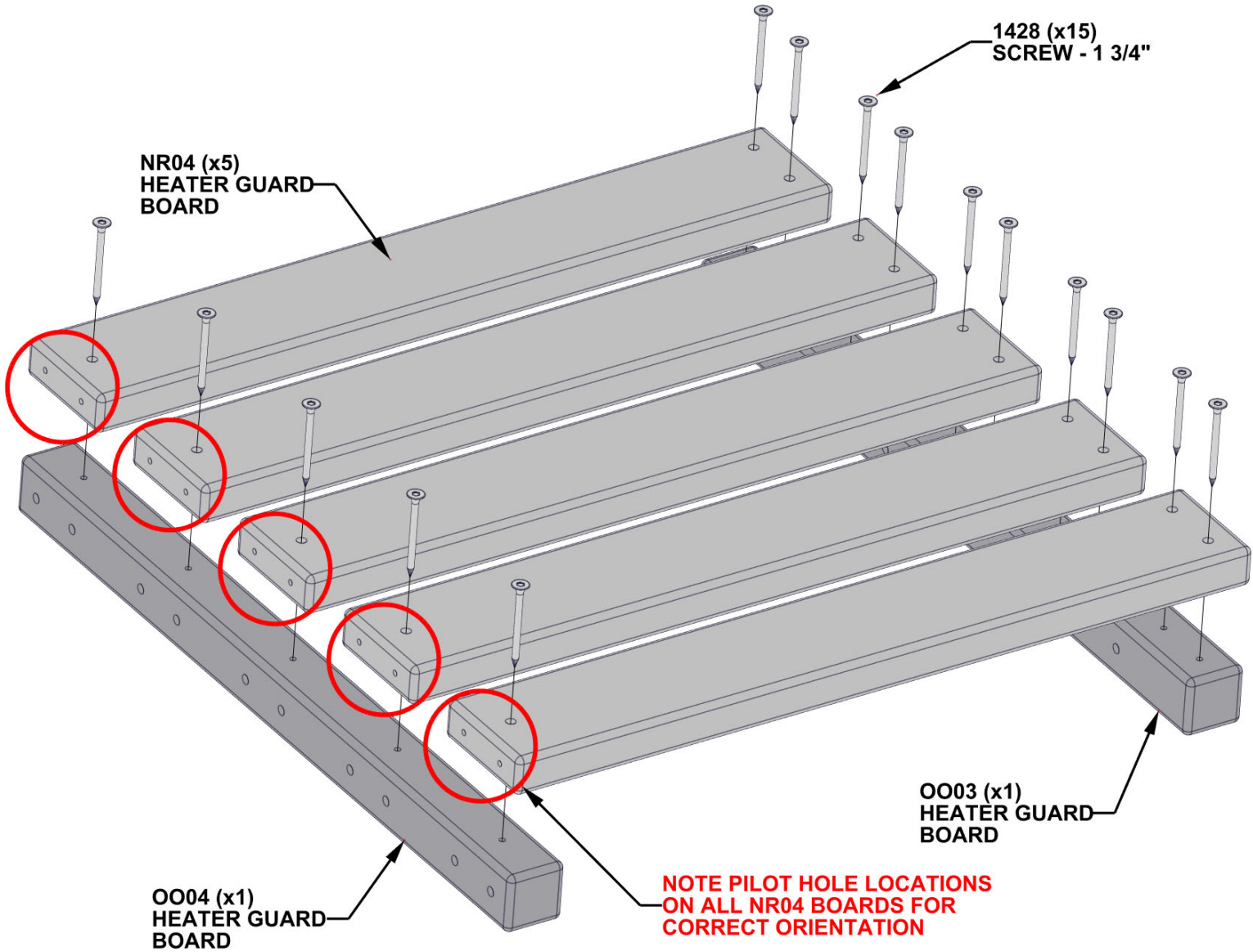

STEP 43 - HEATER GUARD

QTY	PART NUMBER	DESCRIPTION
30	H101428	SCREW TFH 8X1 3/4 SS-BLK



NR01 HEATER GUARD BOARD - W4L22493
(x5) 13/16"x2 3/8"x20 1/2" (20x60x521)



OO03 HEATER GUARD BOARD - W4L22038
(x1) 1 3/16"x1 3/16"x16 1/8" (30x30x410)

- ALIGN THROUGH HOLES WITH PILOT HOLES AND ATTACH AS SHOWN.

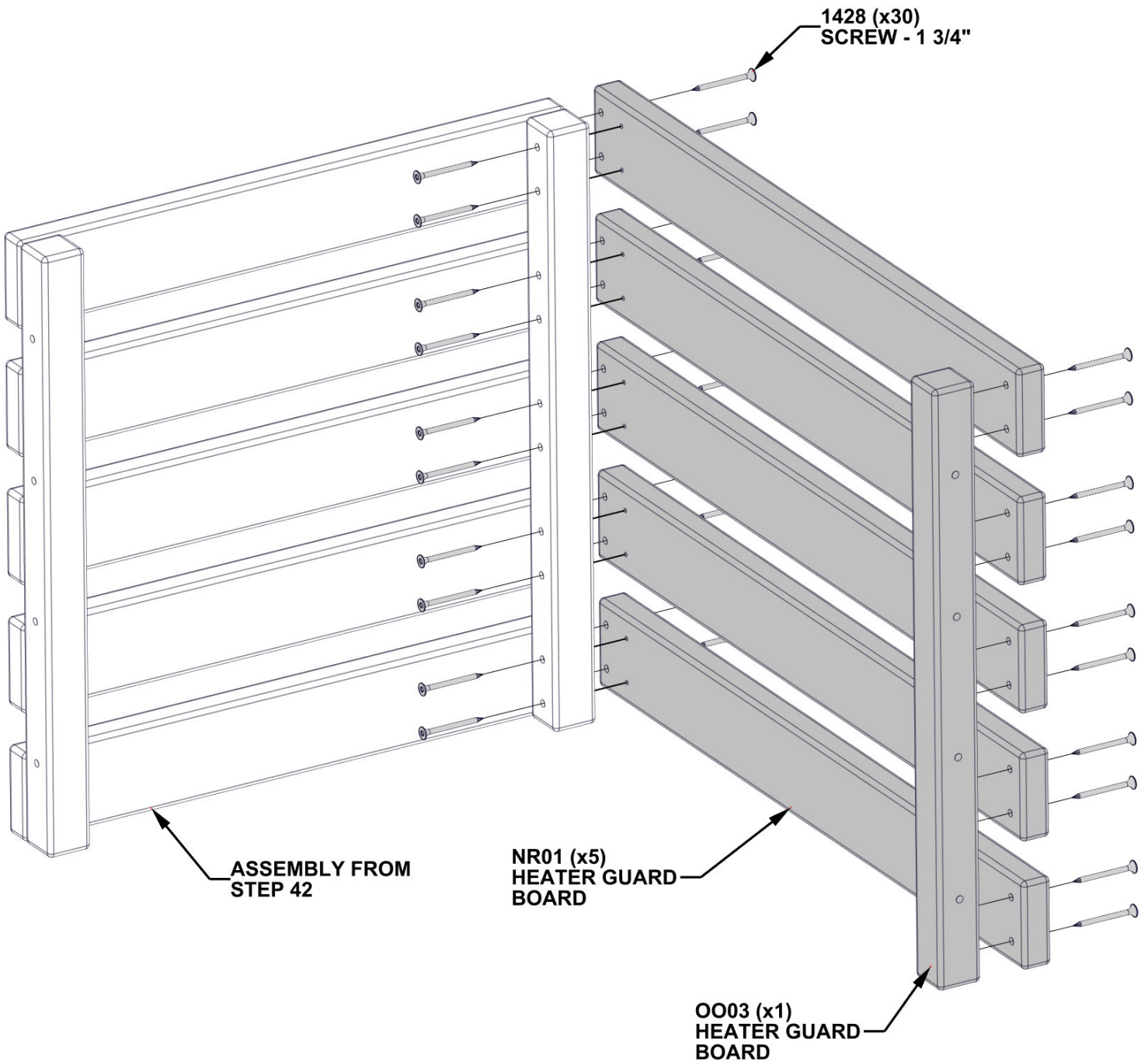

STEP 44 - HEATER GUARD

QTY	PART NUMBER	DESCRIPTION
8	H101429	SCREW TFH 8X2 SS-BLK

- POSITION HEATER GUARD ASSEMBLY AS SHOWN AND ATTACH.

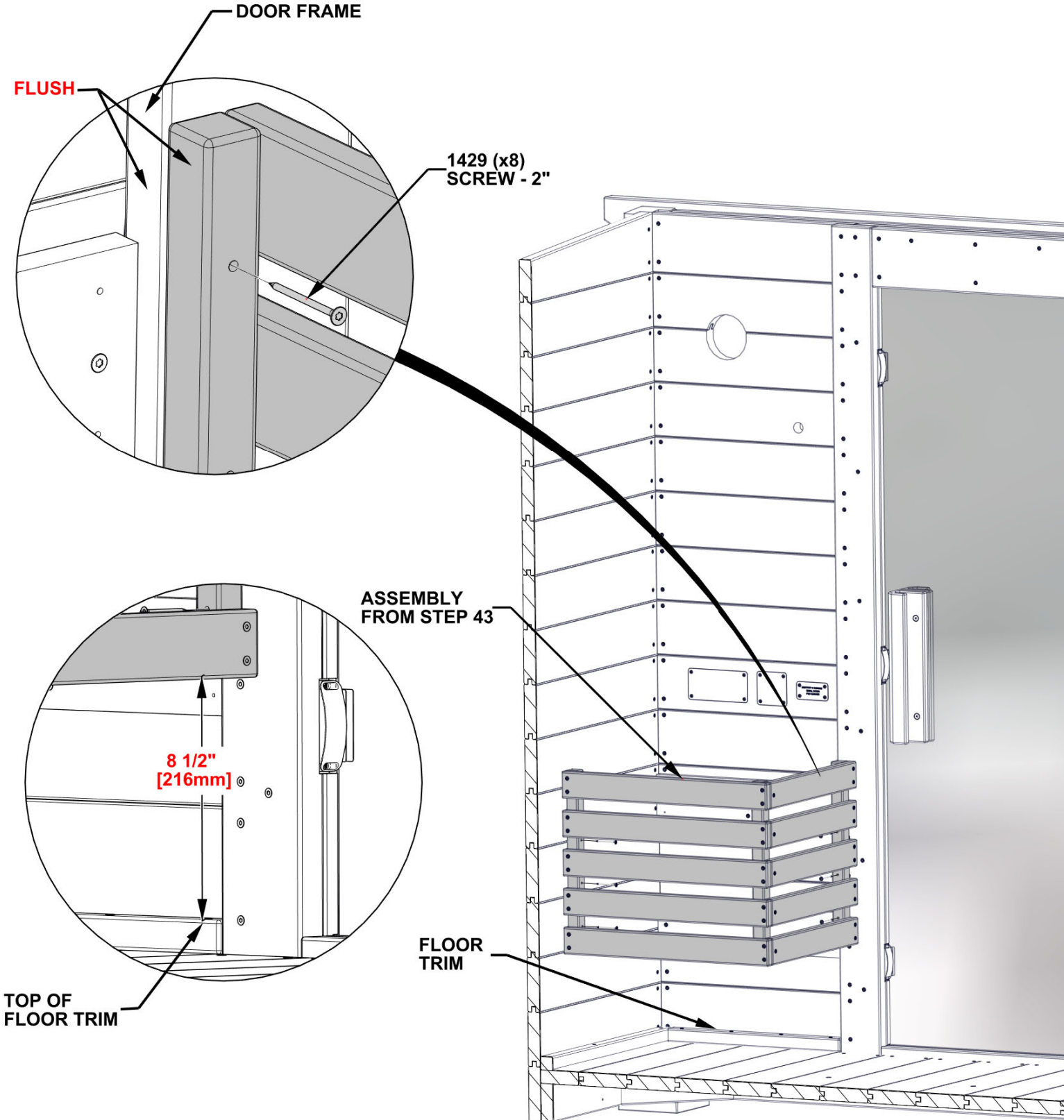

STEP 45 - HEATER ASSEMBLY

QTY	PART NUMBER	DESCRIPTION
8	H101468	SCREW RAISED HEAD 8x1 BLK

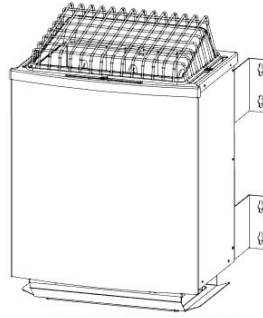

9250253 HEATER
(x1)

- CAUTION: IMPROPER INSTALLATION OF THE HEATER COULD CAUSE HEATER TO FALL CAUSING BURNS OR OTHER INJURIES.
- DANGER! TURN OFF POWER TO THE HEATER AT THE BREAKER BEFORE BEGINNING INSTALLATION OR PERFORMING ANY MAINTENANCE. FAILURE TO TURN OFF THE POWER CAN RESULT IN ELECTROCUTION AND EVEN DEATH.
- ONCE FINISHED WITH THE SAUNA BUILD, A LICENSED ELECTRICIAN IS REQUIRED FOR HEATER INSTALLATION.
- SEE HEATER INSTRUCTIONS FOR INSTALLATION.
- INSERT SCREWS INTO PILOT HOLES IN HEATER GUARD SPACER BOARDS.
- HANG HEATER ONTO SCREWS, ENSURING ALL 8 SCREWS ARE ALIGNED INTO THE SLOTS IN THE HEATER AS SHOWN.

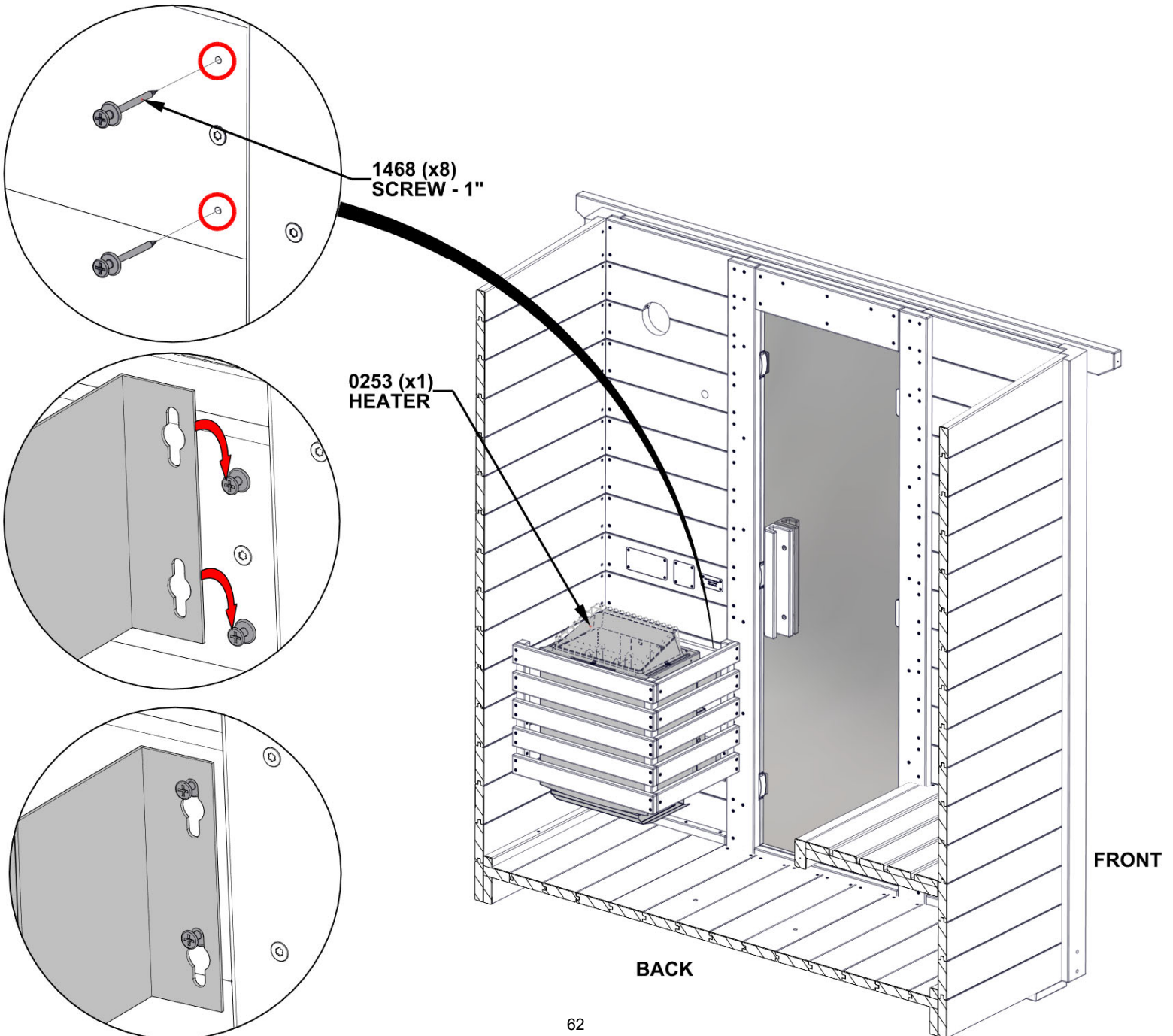

STEP 46 - ROOF ASSEMBLY

QTY	PART NUMBER	DESCRIPTION
2	H100405	WASHER LOCK EXT 6x15
2	H100487	LAG SCREW WH 1/4x2 BLK

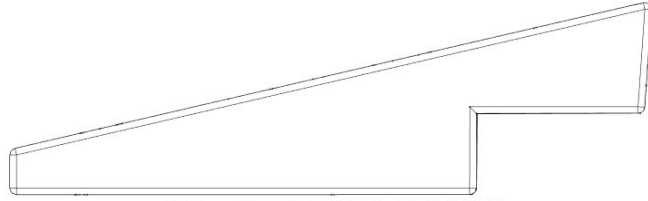

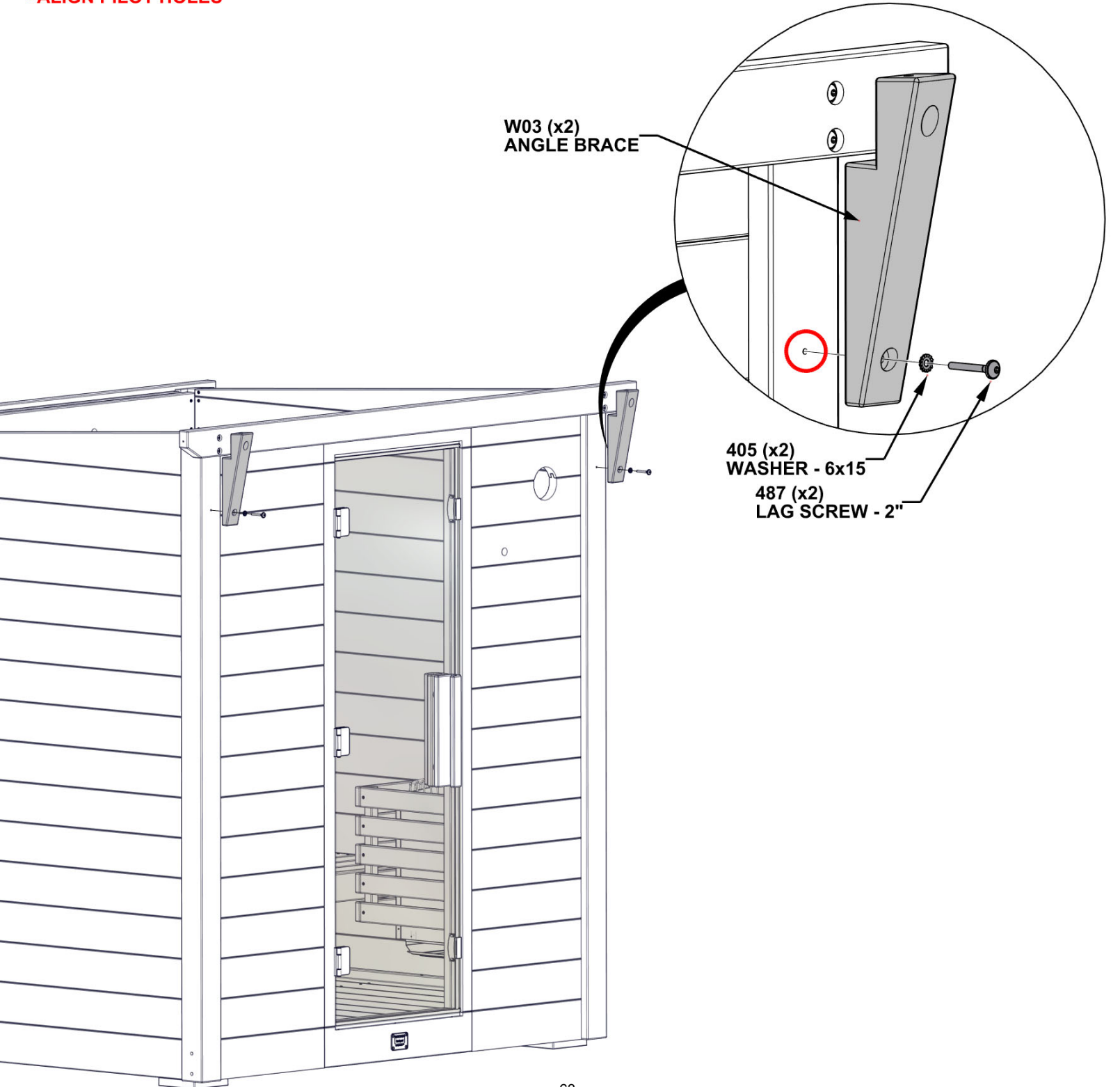

W03 ANGLE BRACE - W4L22409
(x2) 1 15/16"x3 3/8"x11 1/4" (50x86x285)

- ALIGN PILOT HOLES

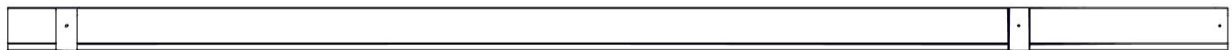

STEP 47 - ROOF ASSEMBLY

	OG07 ROOF BOARD - W4L22470 (x1) 1 3/16"x3 1/8"x88 9/16" (30x79x2250)
	OJ10 ROOF BOARD - W4L22359 (x15) 1 3/16"x5 1/4"x88 9/16" (30x134x2250)
	OG06 ROOF BOARD - W4L22469 (x1) 1 3/16"x3 1/8"x88 9/16" (30x79x2250)

- EVENLY SPACE ROOF BOARDS ON TOP AS SHOWN. DO NOT FASTEN AT THIS TIME.

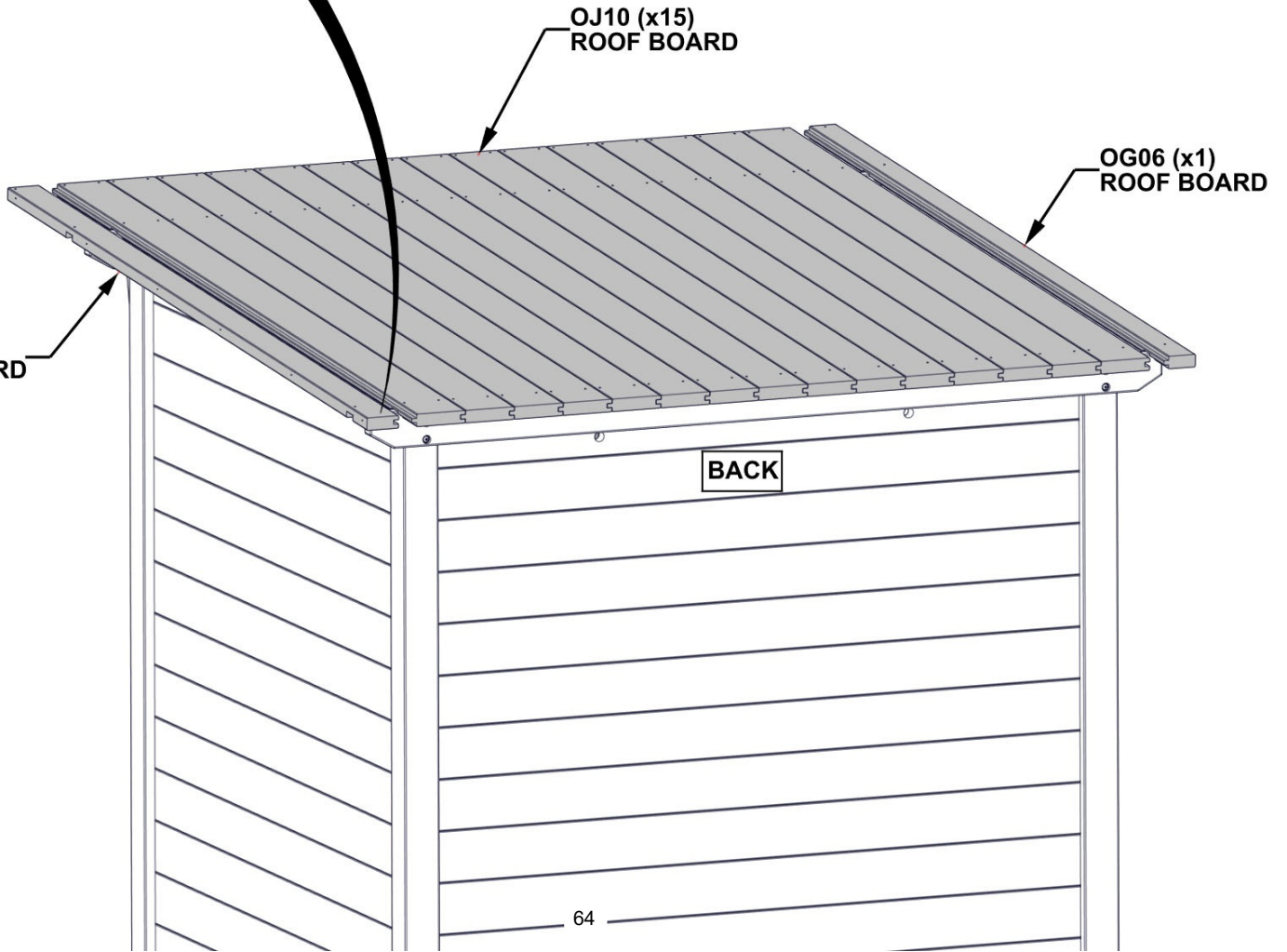
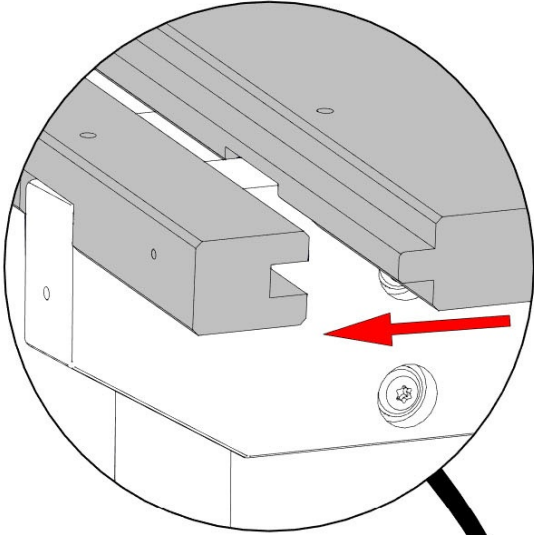

STEP 48 - ROOF ASSEMBLY

QTY	PART NUMBER	DESCRIPTION
2	H101030	SCREW CONFIRMAT 7x2 BLK
6	H101429	SCREW TFH 8X2 SS-BLK



H01 ROOF TRIM - W4L22360
(x1) 15/16"x3 3/8"x89 3/8" (24x86x2270)

- ALIGN THROUGH HOLES WITH PILOT HOLES.
- USE DIMENSIONS SHOWN TO LOCATE H01 AND ATTACH AS SHOWN.

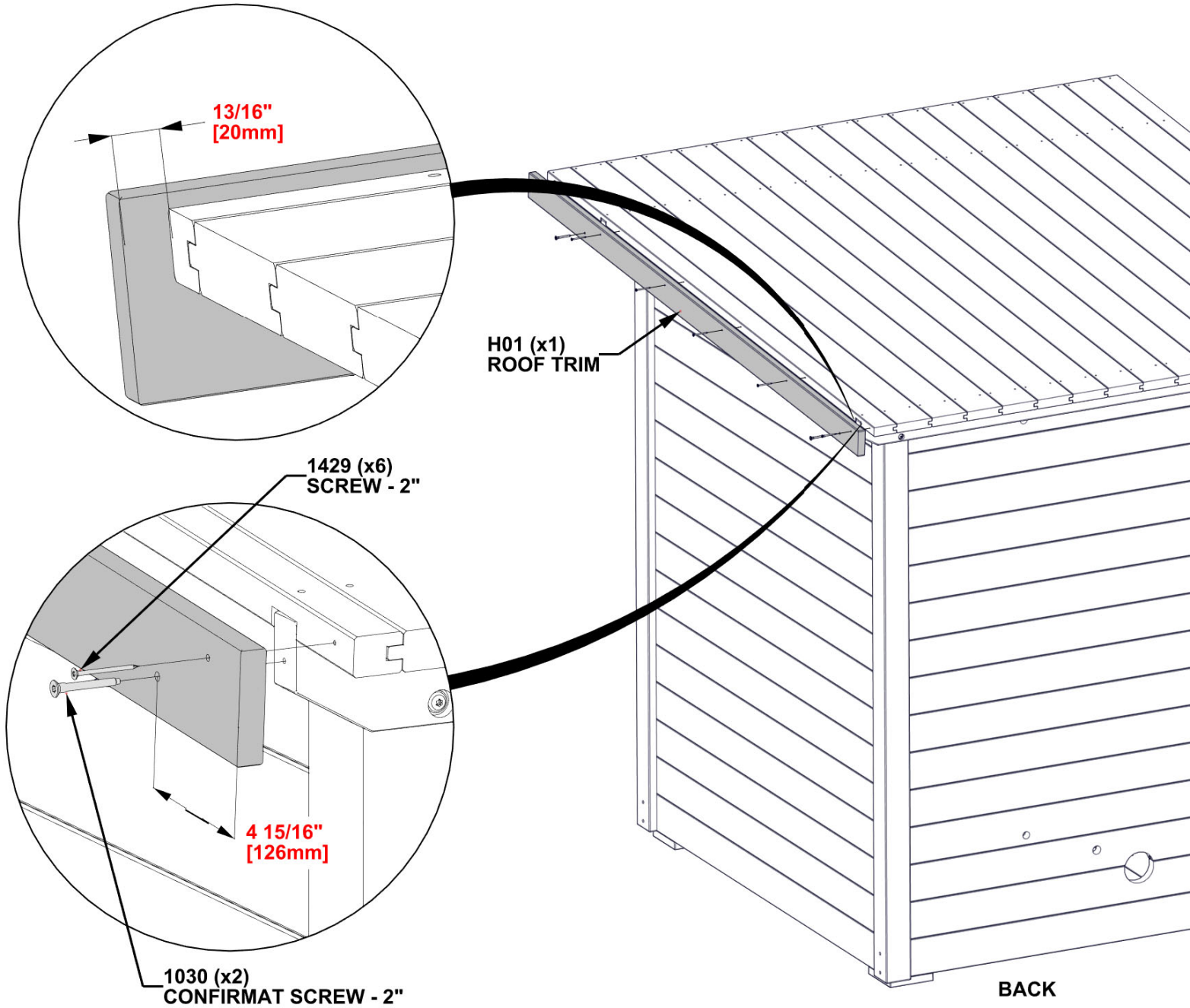

STEP 49 - ROOF ASSEMBLY

QTY	PART NUMBER	DESCRIPTION
2	H101030	SCREW CONFIRMAT 7x2 BLK
6	H101429	SCREW TFH 8X2 SS-BLK



H01 ROOF TRIM - W4L22360
(x1) 15/16"x3 3/8"x89 3/8" (24x86x2270)

- ALIGN THROUGH HOLES WITH PILOT HOLES.
- USE DIMENSIONS SHOWN TO LOCATE H01 AND ATTACH AS SHOWN.

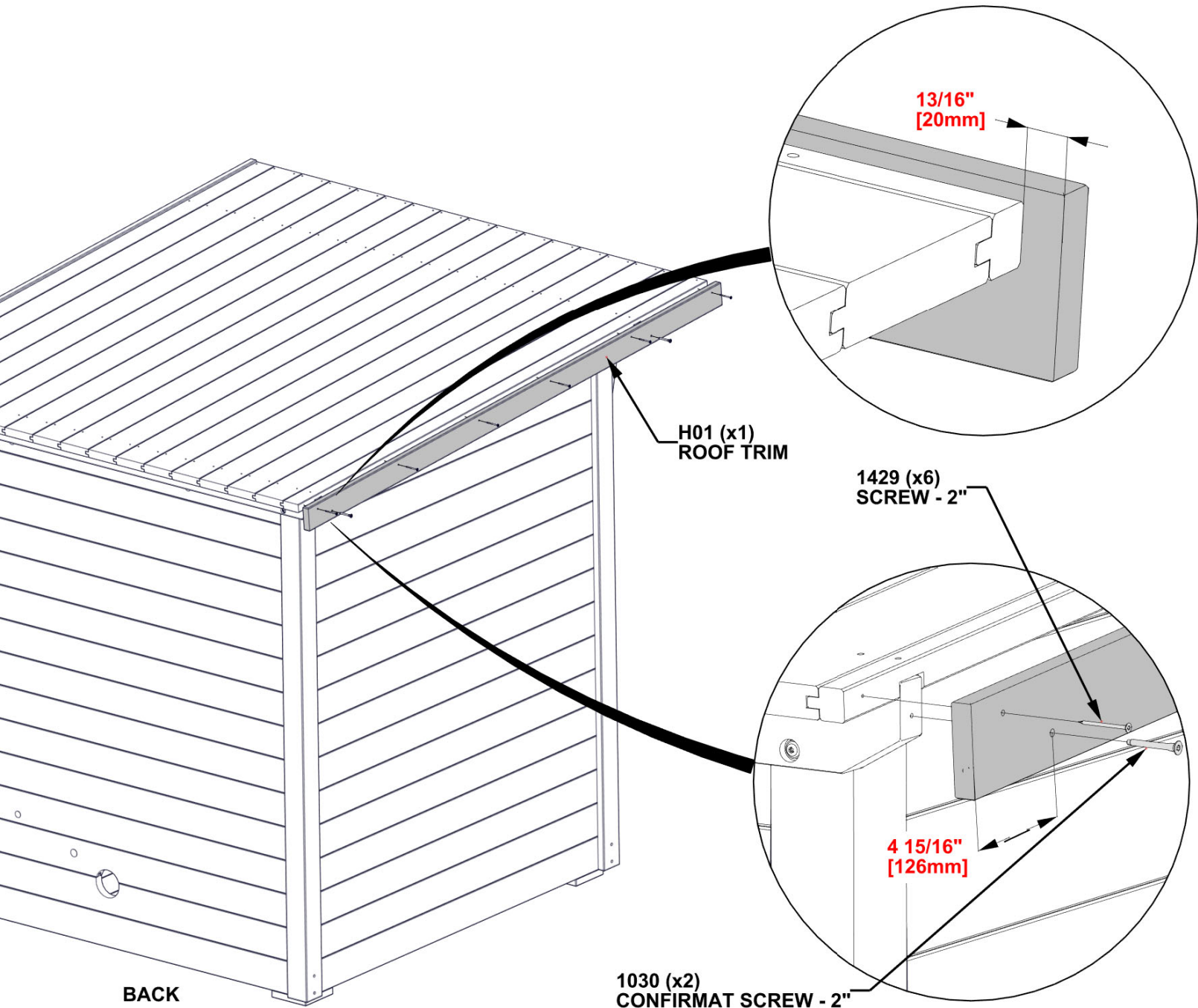

STEP 50 - ROOF ASSEMBLY

QTY	PART NUMBER	DESCRIPTION
4	H101428	SCREW TFH 8X1 3/4 SS-BLK
60	H101429	SCREW TFH 8X2 SS-BLK

- ADJUST ROOF BOARDS AS NEEDED TO BE FLUSH BOTH AT FRONT AND BACK.
- ATTACH AS SHOWN.

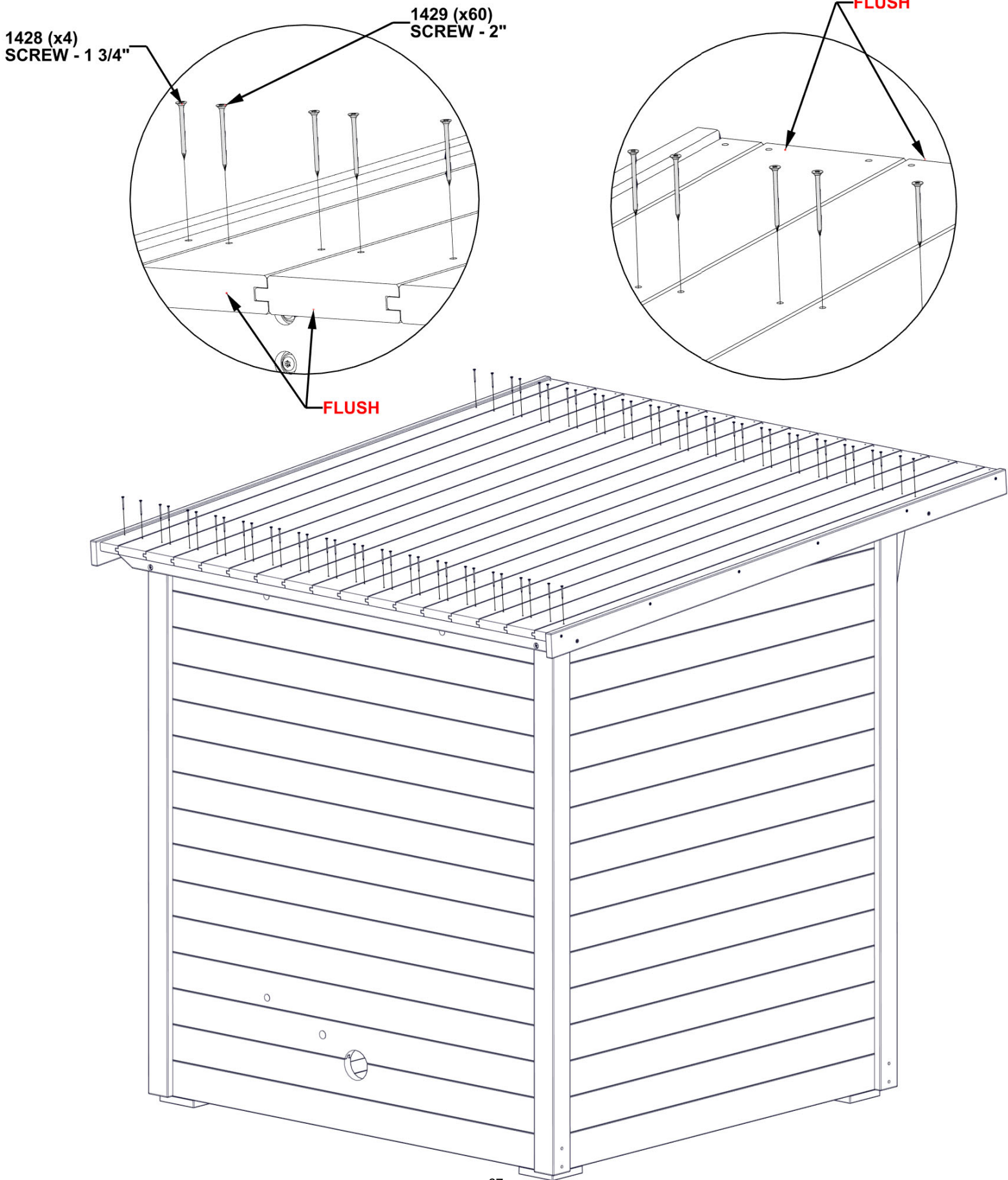

STEP 51 - ROOF ASSEMBLY

QTY	PART NUMBER	DESCRIPTION
11	H101429	SCREW TFH 8X2 SS-BLK



W06 FASCIA - W4L22457
(x1) 1 15/16"x3 3/8"x80" (50x86x2032)

- ALIGN THROUGH HOLES WITH PILOT HOLES AND ATTACH AS SHOWN.

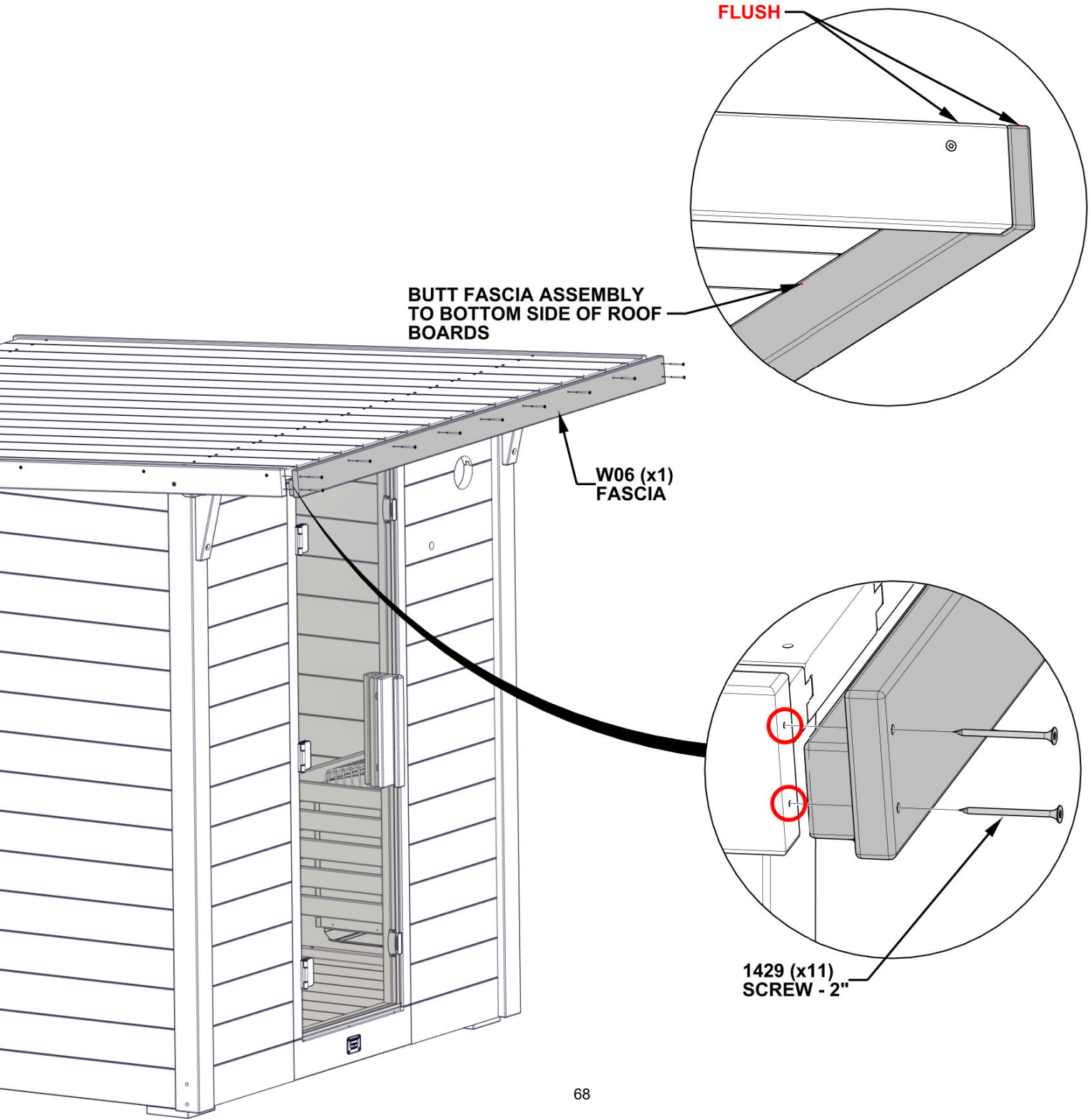

STEP 52 - ROOF ASSEMBLY

QTY	PART NUMBER	DESCRIPTION
2	H100405	WASHER LOCK EXT 6x15
2	H100487	LAG SCREW WH 1/4x2 BLK
32	H101429	SCREW TFH 8X2 SS-BLK

- ONCE FASCIA ASSEMBLY IS LINED UP WITH THROUGH HOLES IN ROOF BOARDS FROM THE PREVIOUS STEP, ATTACH AS SHOWN.

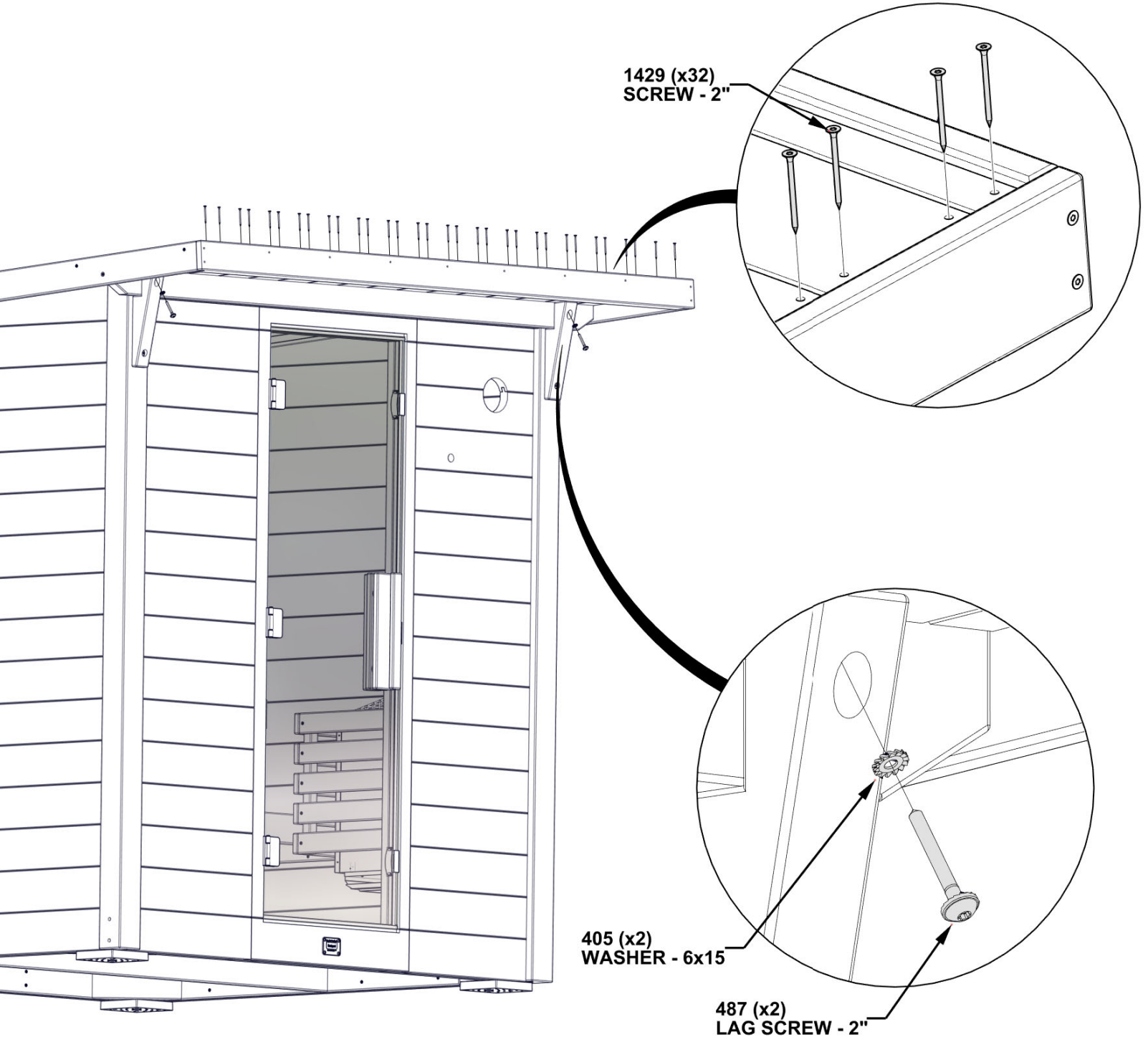

STEP 53 - ROOF ASSEMBLY

QTY	PART NUMBER	DESCRIPTION
17	H101429	SCREW TFH 8X2 SS-BLK



NG04 FASCIA - W4L22458
(x1) 13/16"x3 1/8"x78 1/8" (20x80x1984)

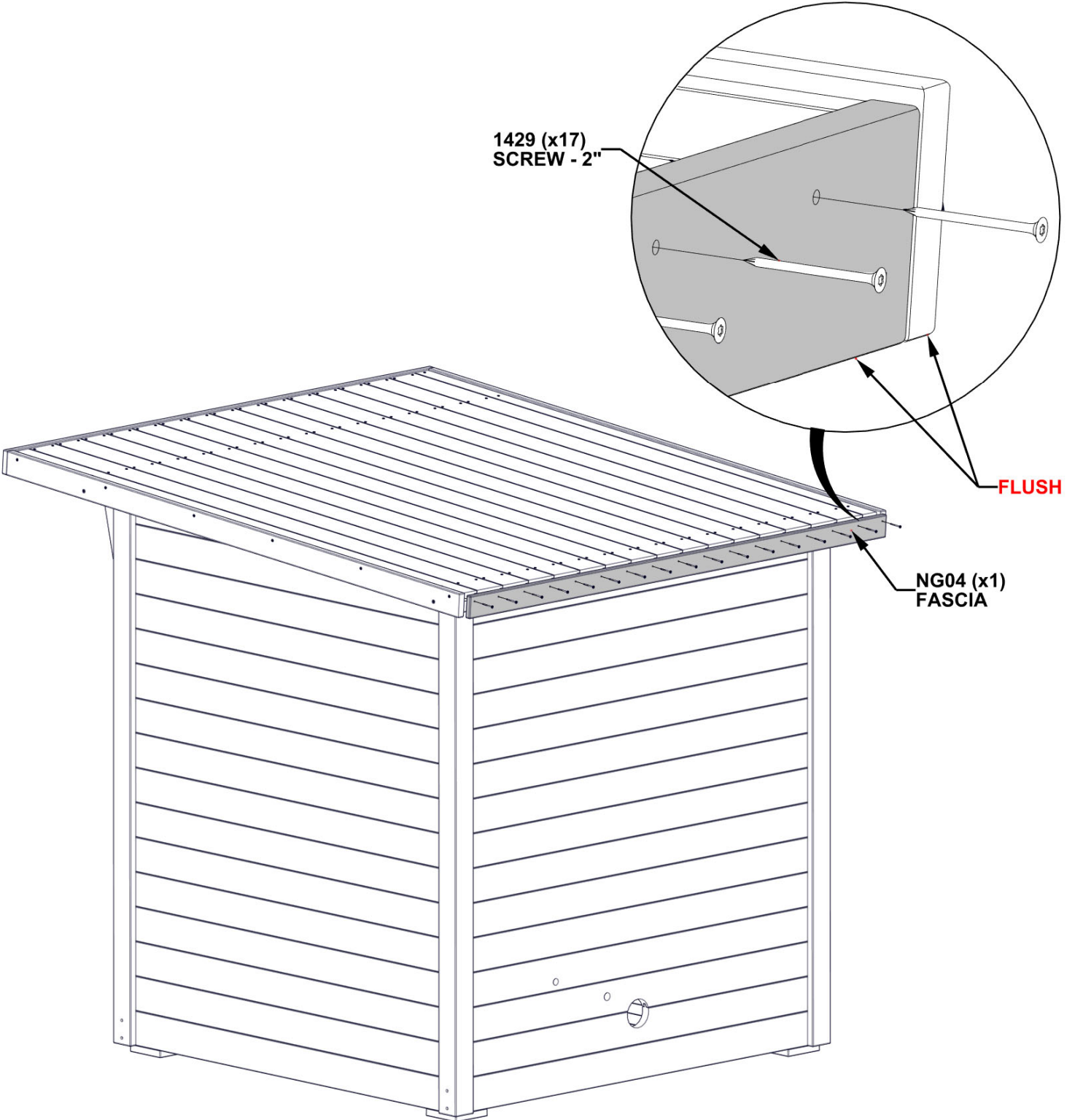

STEP 54 - ROOF ASSEMBLY



A4M05912 29GA SHEETING
(x3)

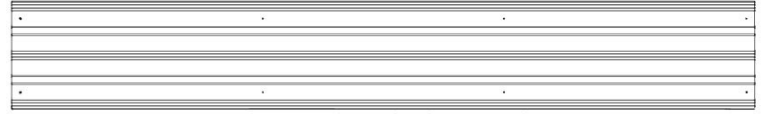

A4M05913 29GA SHEETING
(x2)

- **WARNING: USE GLOVES WHEN HANDLING STEEL SHEETING.**
- **IMPORTANT: REMOVE BLUE FILM BEFORE INSTALLATION.**
- **STARTING ON LEFT HAND SIDE, BUTT SHEETING AGAINST ROOF TRIM AND FASCIA AS SHOWN.**
- **CONTINUE FROM LEFT TO RIGHT BY LAYING SHEETING DOWN OVERLAPPING EACH SHEET BY ONE RIB.**

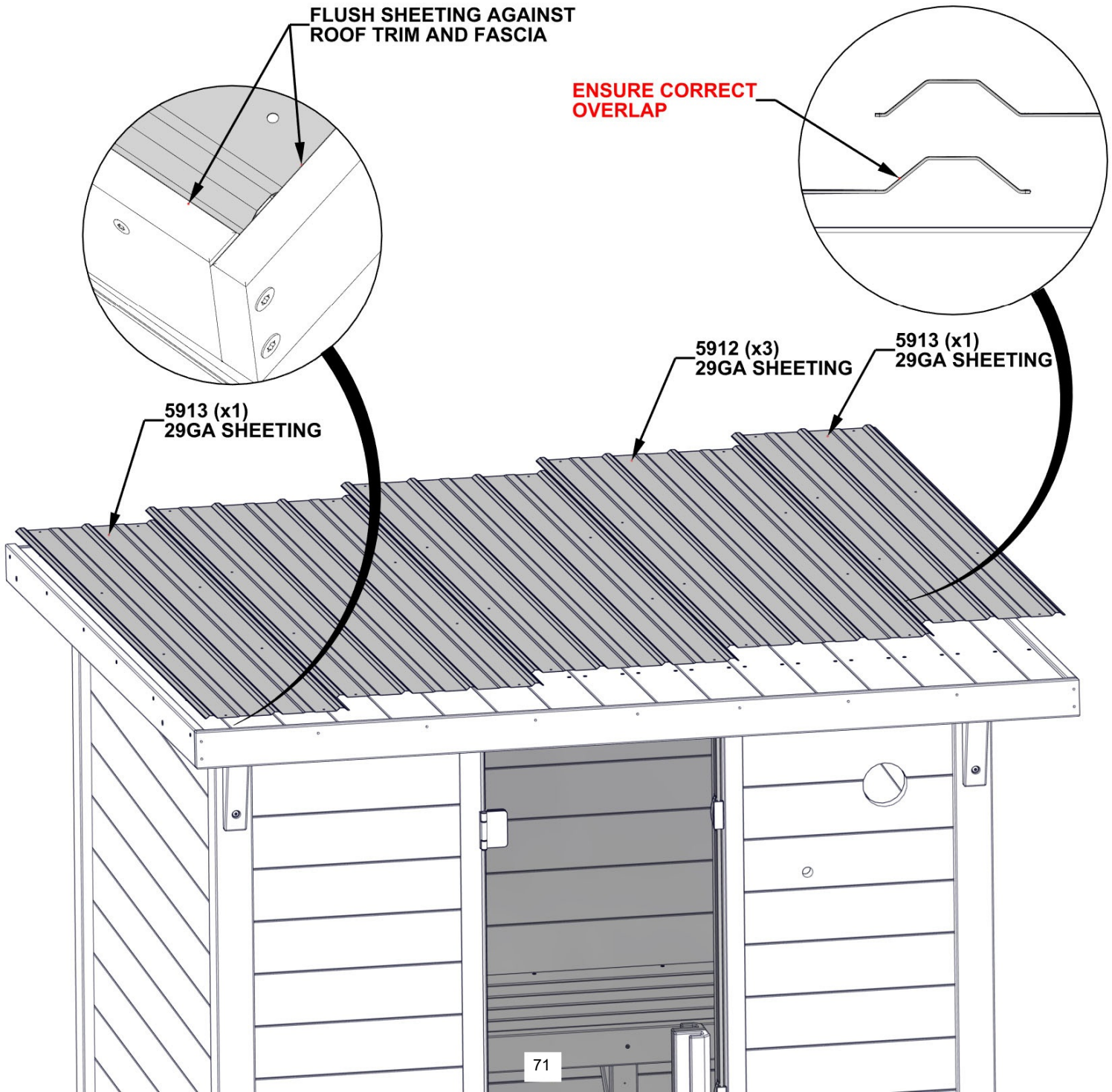

STEP 55 - ROOF ASSEMBLY

QTY	PART NUMBER	DESCRIPTION
30	H101117	SCREW WOODGRIP 10-16x3/4" BLK

- **WARNING: USE GLOVES WHEN HANDLING STEEL SHEETING.**
- **ONCE SHEETING IS IN PLACE FROM PREVIOUS STEP, FASTEN AS SHOWN.**
- **THE BACK OF THE SAUNA WILL HAVE A SMALL OVERHANG AS SHOWN.**
- **DO NOT INSTALL BACK ROW OF SCREWS AT THIS TIME**

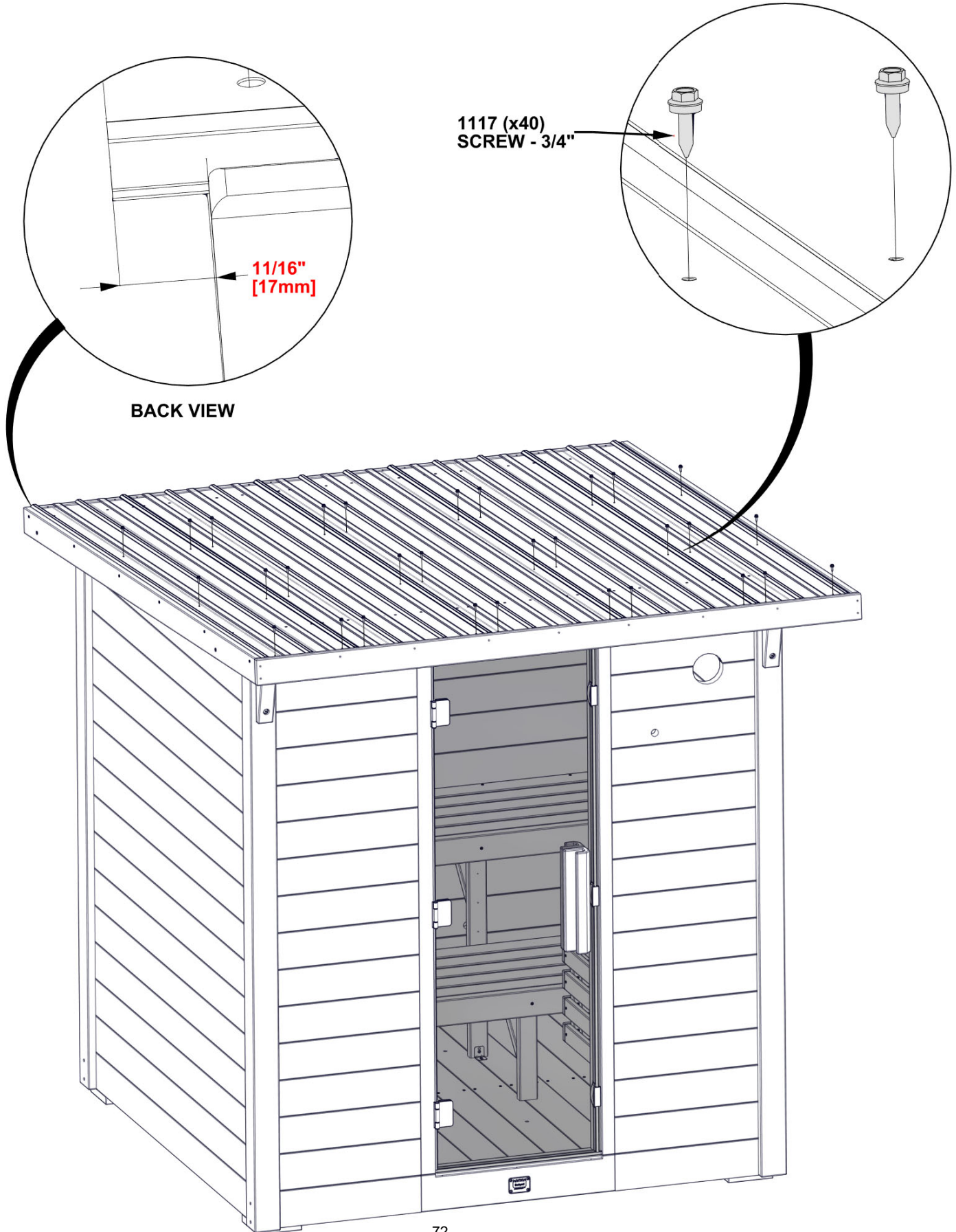

STEP 56 - ROOF ASSEMBLY

QTY	PART NUMBER	DESCRIPTION
8	H101116	SCREW SELF TAPPING 1/4x1 BLK

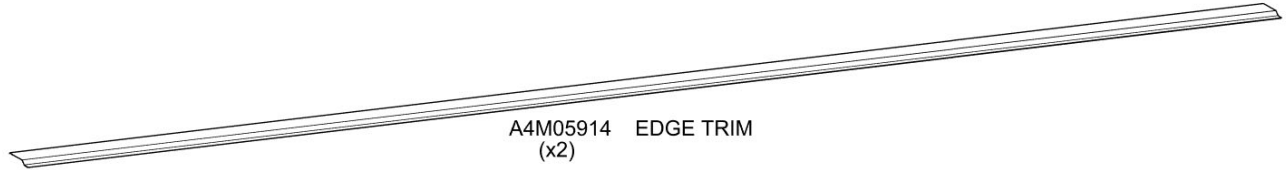

- **WARNING: USE GLOVES WHEN HANDLING STEEL SHEETING.**
- **IMPORTANT: REMOVE BLUE FILM BEFORE INSTALLATION.**
- FLUSH EDGE TRIM WITH SHEETING INSTALLED IN PREVIOUS STEP.
- ATTACH AS SHOWN AT THE APPROXIMATE LOCATIONS ON BOTH SIDES OF SAUNA.

LOCATE THE TWO CENTER ROWS OF SCREWS STRAIGHT ACROSS FROM PREVIOUS INSTALLED SCREWS IN SHEETING

FLUSH WITH BACK SIDE OF FASCIA

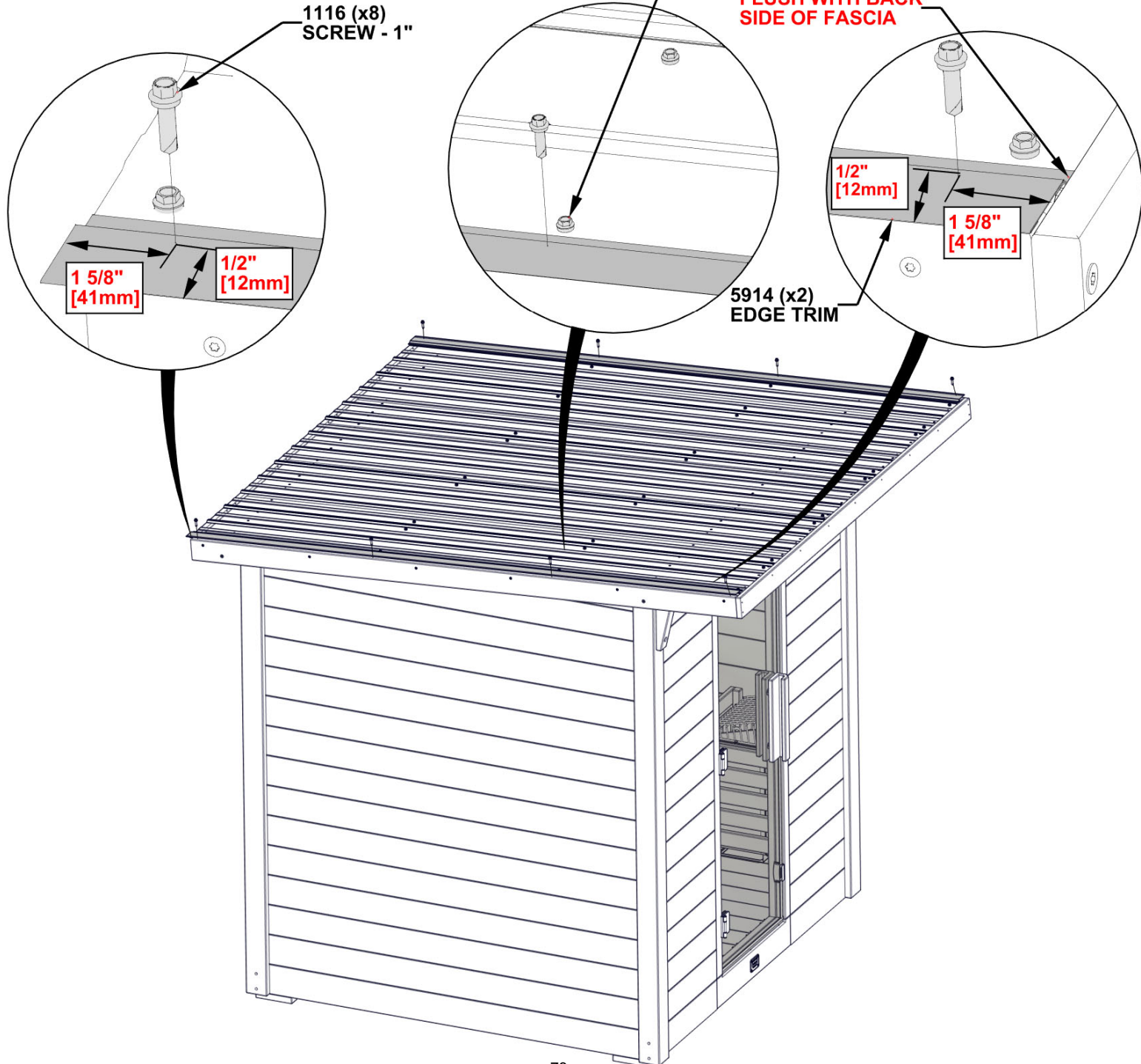

STEP 57 - ROOF ASSEMBLY

QTY	PART NUMBER	DESCRIPTION
8	H101116	SCREW SELF TAPPING 1/4x1 BLK

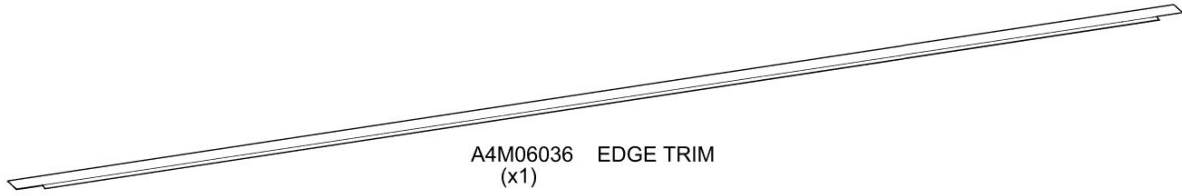

- **WARNING: USE GLOVES WHEN HANDLING STEEL SHEETING.**
- **IMPORTANT: REMOVE BLUE FILM BEFORE INSTALLATION.**

- POSITION EDGE TRIM AS SHOWN. USE DIMENSION TO LOCATE AND ATTACH SCREW. USING THE SAME DIMENSIONS, FASTEN ANOTHER SCREW TO THE OTHER END OF EDGE TRIM.
- AFTER SECURING SCREWS AT BOTH ENDS, SKIP A RIB, AND INSTALL THREE ADDITIONAL SCREWS FROM EACH END AT ALTERNATING RIBS.

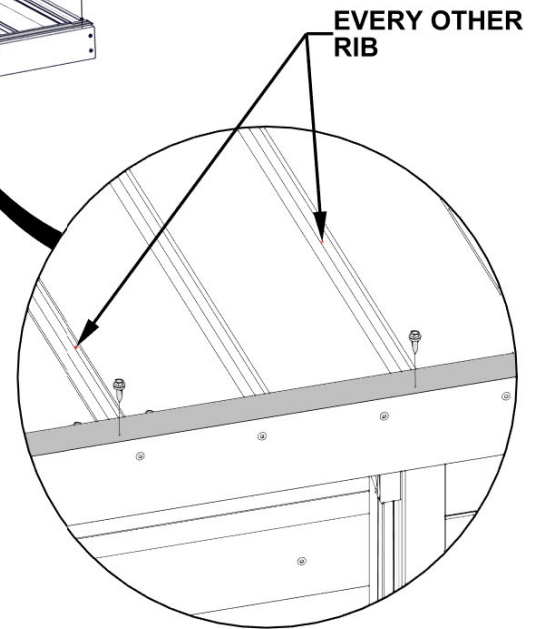
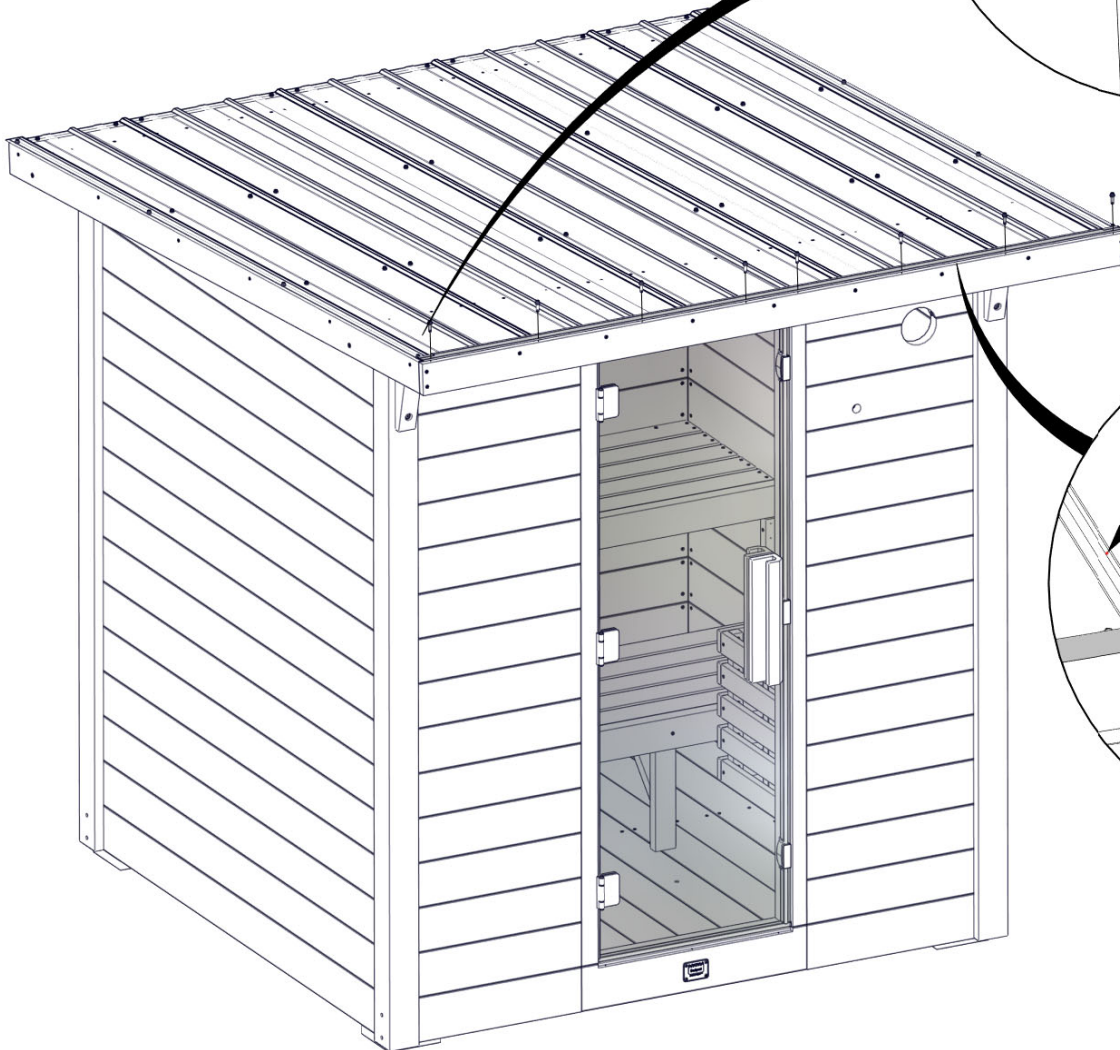
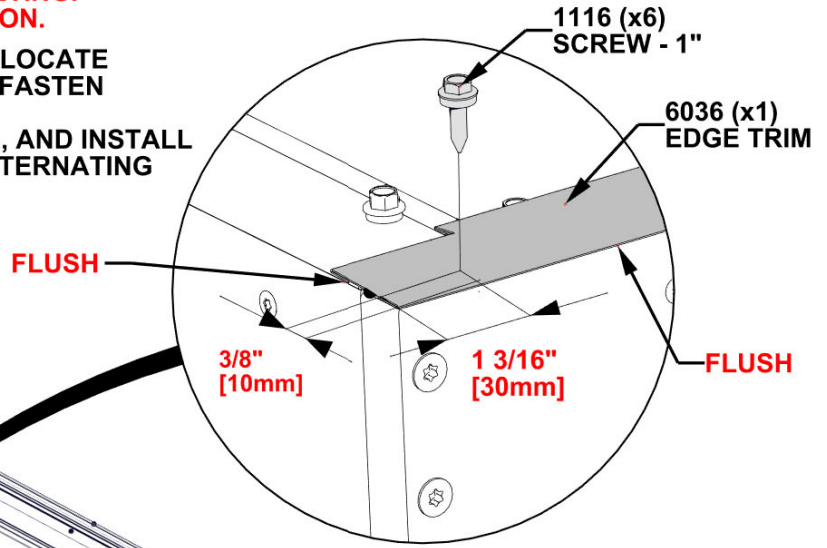

STEP 58 - ROOF ASSEMBLY

QTY	PART NUMBER	DESCRIPTION
10	H101117	SCREW WOODGRIP 10-16x3/4" BLK



A4M06037 DRIP EDGE
(x1)

- **WARNING: USE GLOVES WHEN HANDLING STEEL SHEETING.**
- **IMPORTANT: REMOVE BLUE FILM BEFORE INSTALLATION.**
- **INSERT DRIP EDGE UNDER ROOF SHEETING AS SHOWN.**
- **PUSH IN EVENLY UNTIL DRIP EDGE CONTACTS THE BACK FASCIA BOARD AND ATTACH BACK ROW OF WOODGRIP SCREWS.**

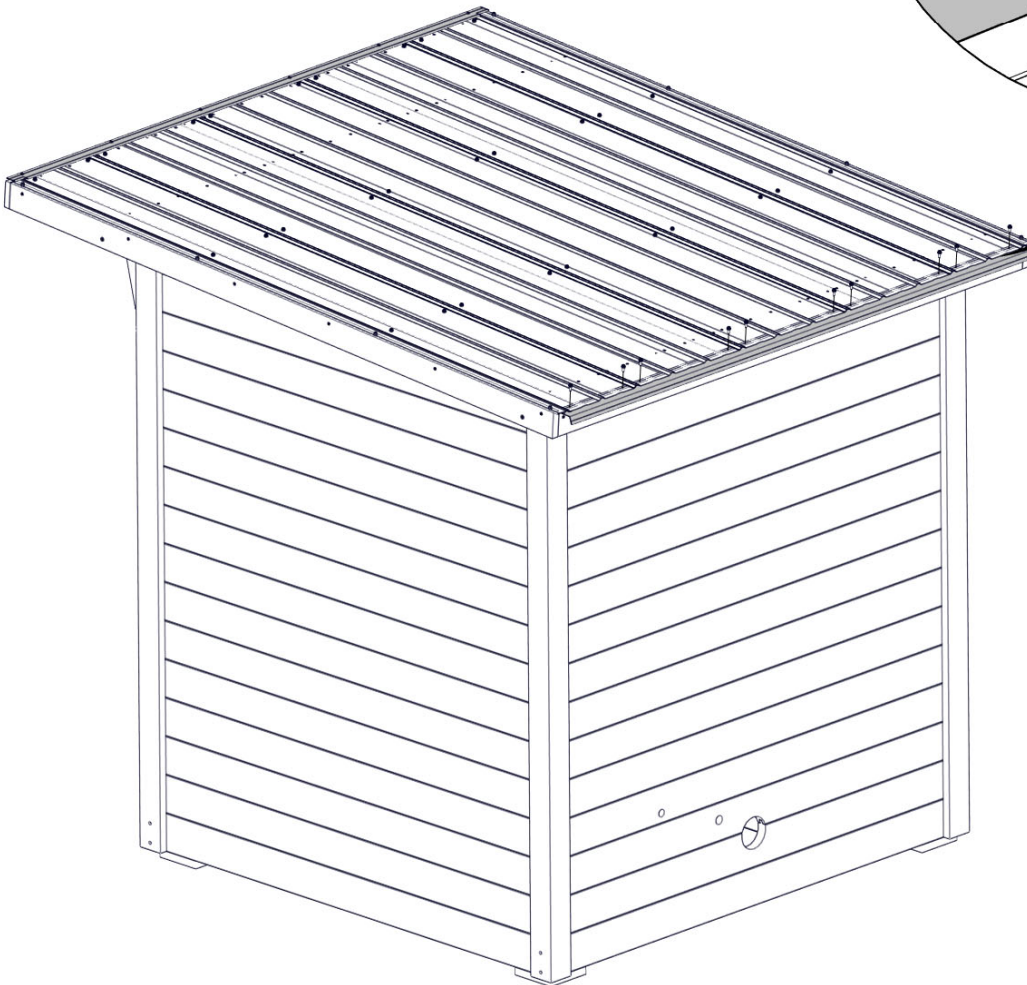
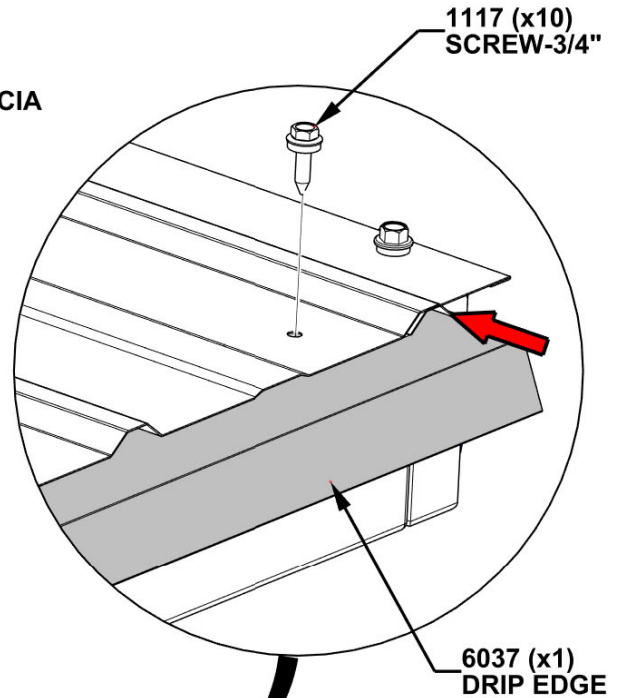

STEP 59 - CONTROL PANEL

QTY	PART NUMBER	DESCRIPTION
2	H100627	SCREW PFH 6x3/4 BLK

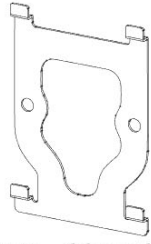

A4M05590-03 CONTROL PANEL MOUNTING BRACKET (x1)

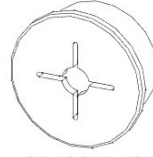

A6P001467 SILICONE GROMMET 25mm (x1)

- CENTER MOUNTING BRACKET SLIGHTLY OVER CUTOUT IN WALL PANEL AND ATTACH AS SHOWN.
- INSERT GROMMET.

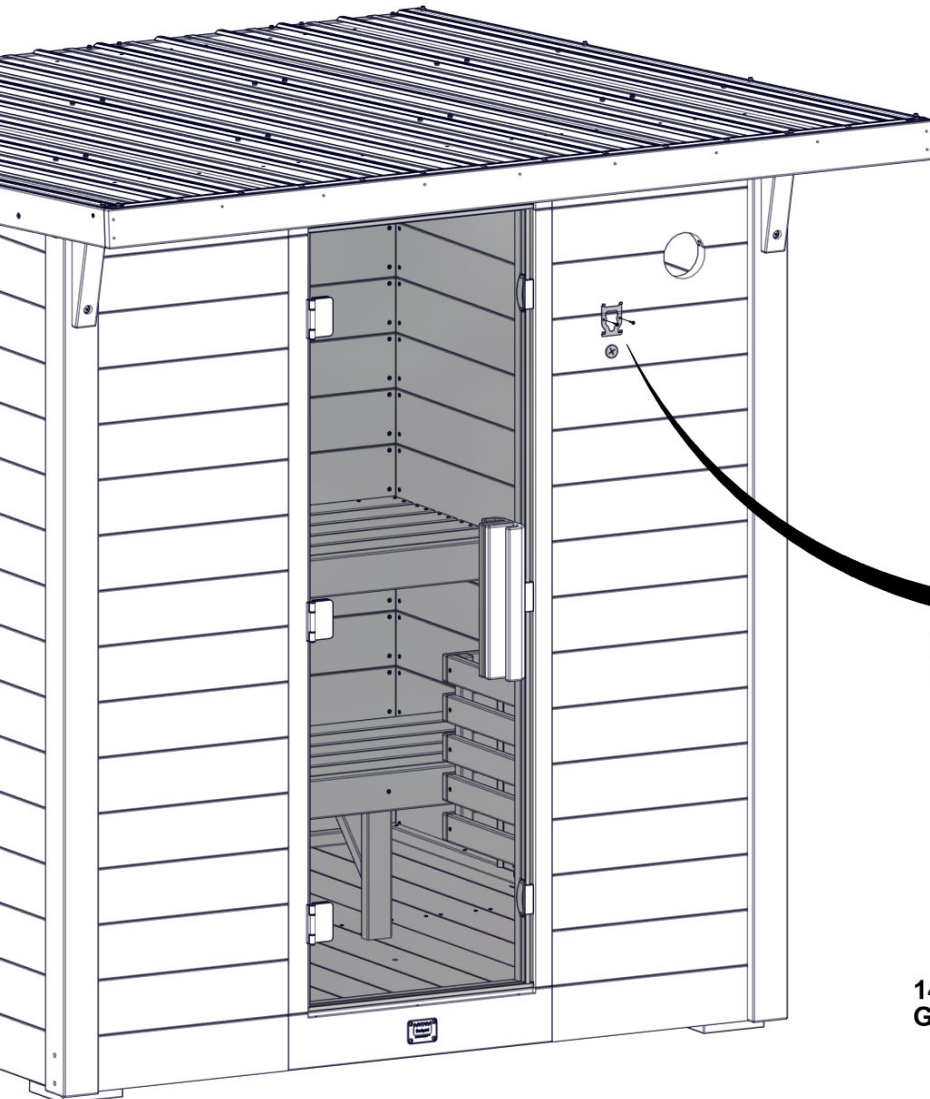

CONTROL PANEL MOUNTING BRACKET (x1)

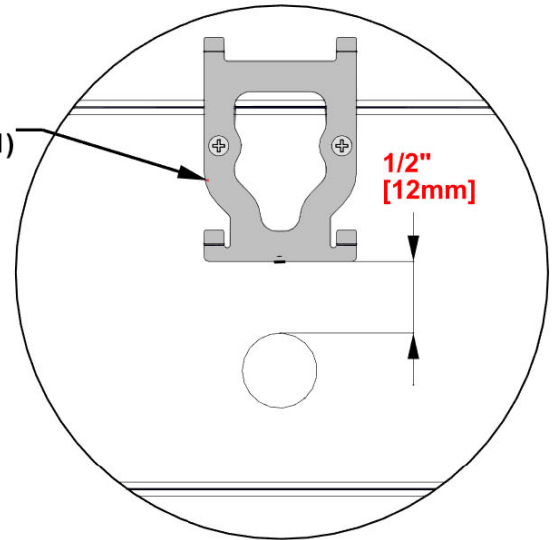

1/2" [12mm]

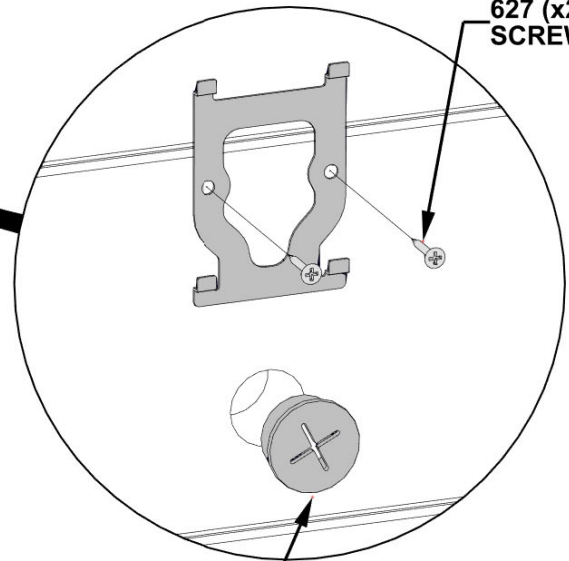

627 (x2) SCREW - 3/4"

1467 (x1) GROMMET - 25mm

STEP 60 - CONTROL PANEL INSTALLATION

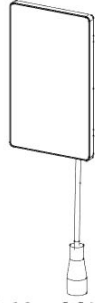

A4M05590-02 CONTROL PANEL
(x)

CONTROL PANEL (x1)

HANG CONTROL PANEL ON
HOOKS ON CONTROL PANEL
BRACKET AND SNAP INTO
PLACE

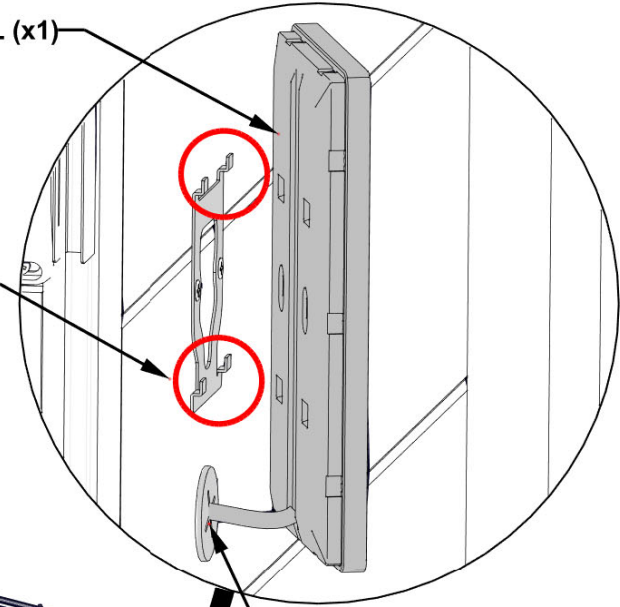

RUN CORD THROUGH
GROMMET

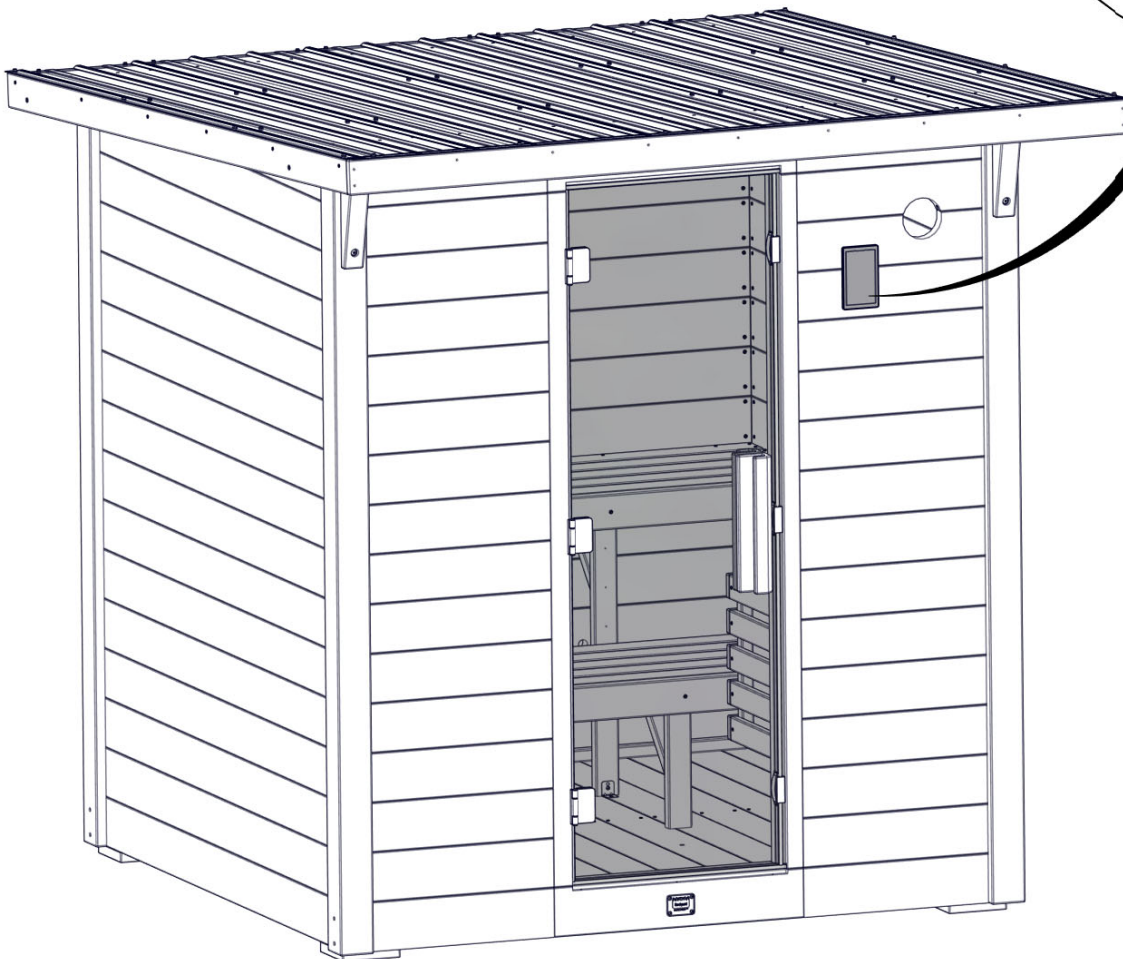

STEP 61 - CONTROL PANEL

QTY	PART NUMBER	DESCRIPTION
4	H101428	SCREW TFH 8X1 3/4 SS-BLK

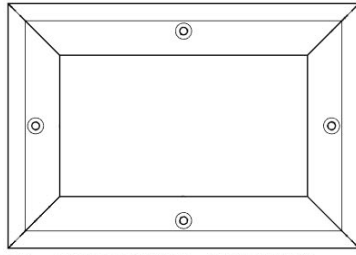

TF01 TRIM FRAME - W2A04797
(x1) 7/8"x5 9/16"x8 1/16" (22x142x204)

- PLACE TRIM FRAME ON CONTROL PANEL ENSURING IT SEATS AROUND THE CONTROL PANEL AND ATTACH AS SHOWN.

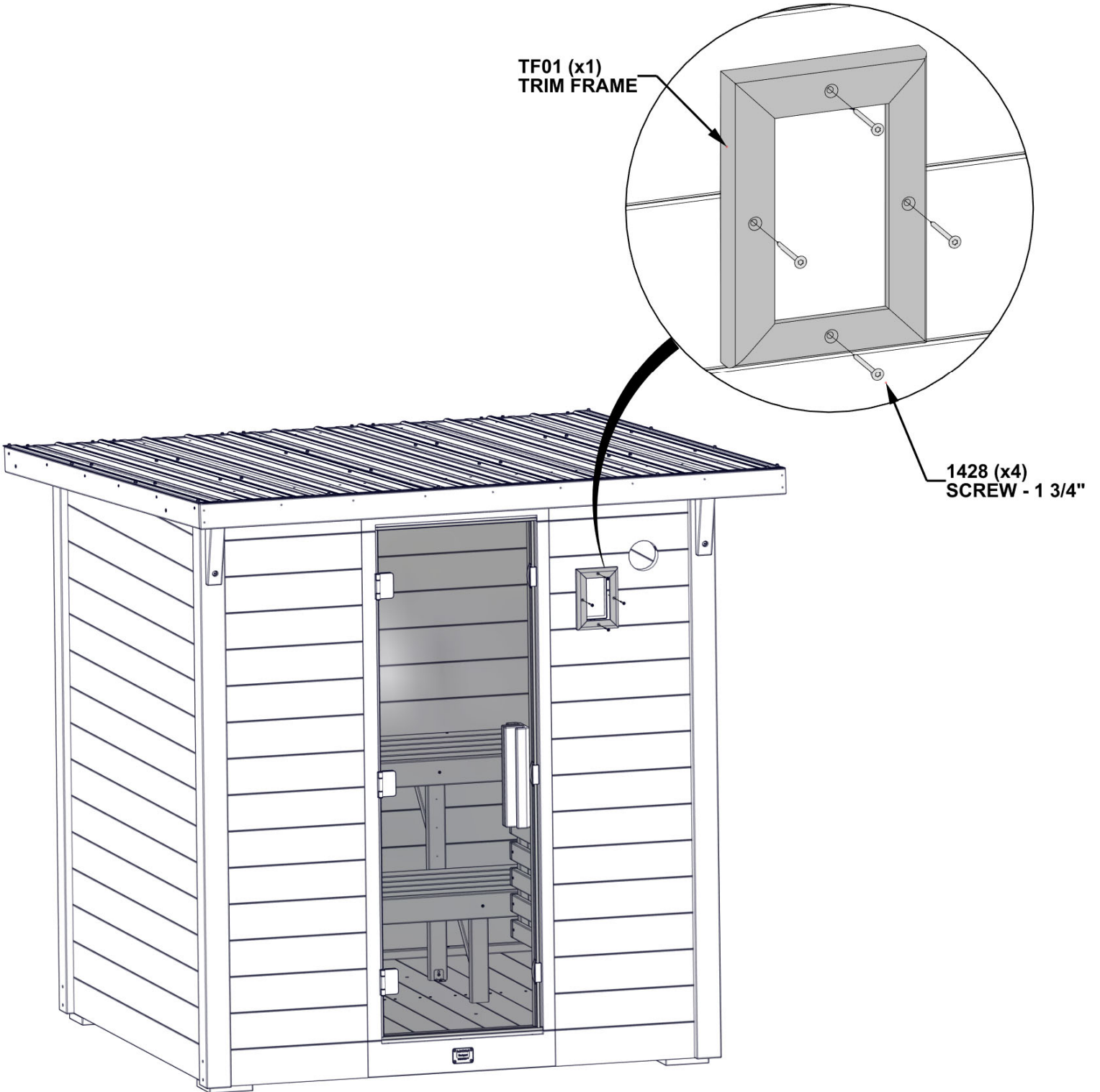

STEP 62 - WIREWAY ASSEMBLY

QTY	PART NUMBER	DESCRIPTION
4	H101429	SCREW TFH 8X2 SS-BLK

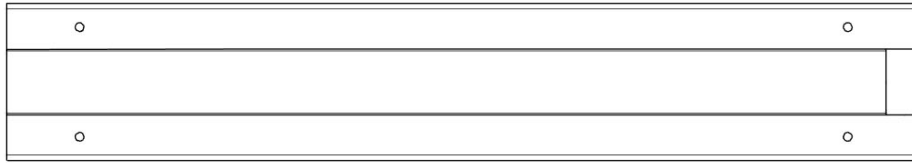

OG12 WIREWAY BOARD - W4L22389
(x1) 1 3/16"x3 3/8"x19 3/4" (30x86x501)



A4M05590-10 WIRING HARNESS
(x1)

- CONNECT WIRING HARNESS TO CORD FROM STEP 60
- HOLD CONNECTED CORDS UP TO THE TOP OF THE SAUNA, CENTER WIREWAY BOARD OVER HOLE IN FRONT WALL, AND ATTACH BOARD AS SHOWN.
- TAKE CAUTION WHEN ATTACHING SCREWS TO PREVENT PINCHING OR PENETRATING CORDS.

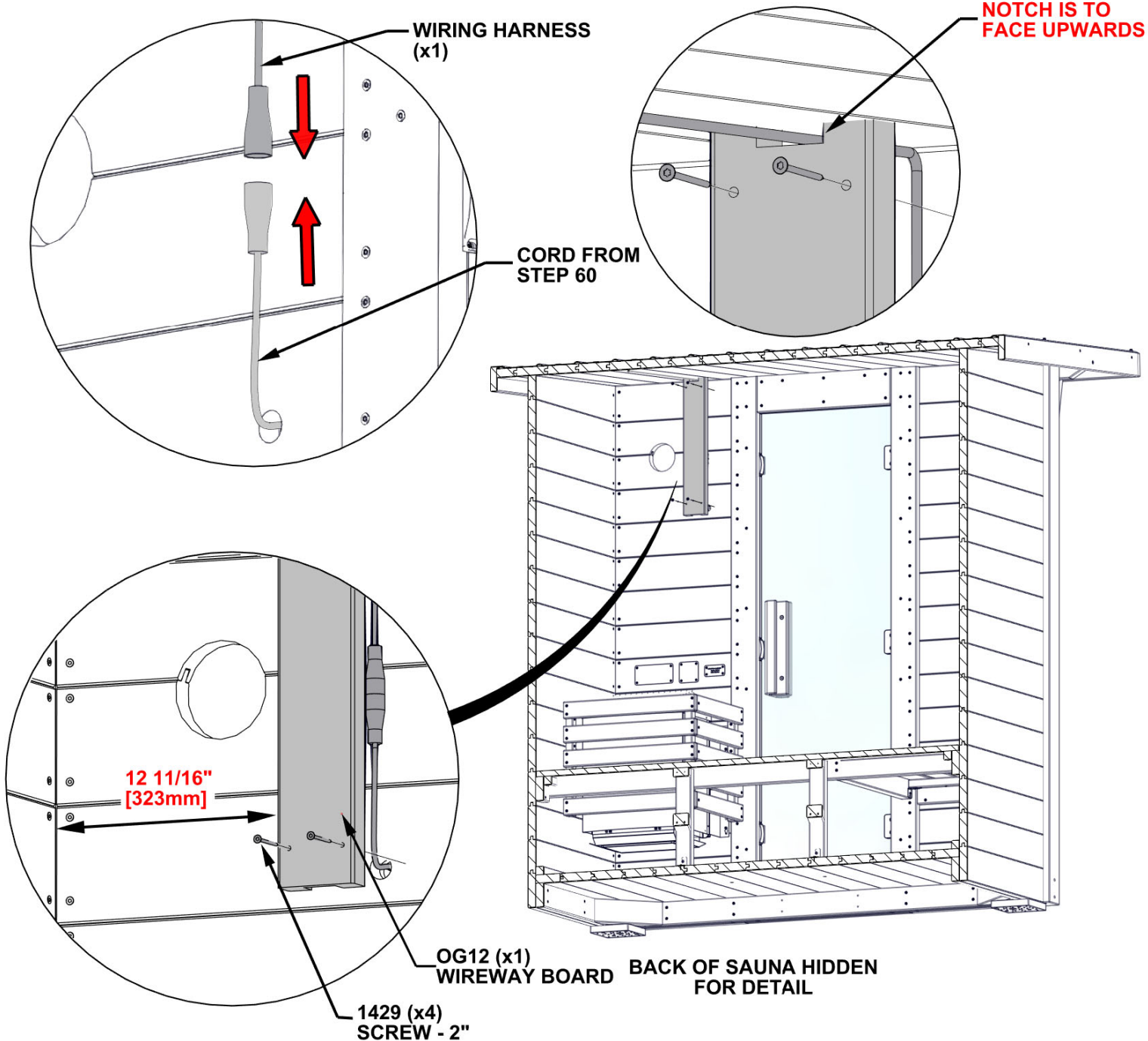

STEP 63 - WIREWAY ASSEMBLY

QTY	PART NUMBER	DESCRIPTION
2	H101429	SCREW TFH 8X2 SS-BLK

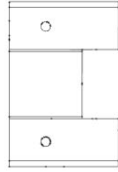

OG11 WIREWAY BOARD - W4L22733
(x1) 1 3/16"x2 1/4"x3 3/8" (30x57x86)

- RUN CORD FROM PREVIOUS STEP STRAIGHT BACK ALONG THE CEILING AND USE DIMENSION SHOWN TO LOCATE AND ATTACH OG11.
- RUN EXCESS CORD THROUGH HOLE IN BACK WALL AS SHOWN.

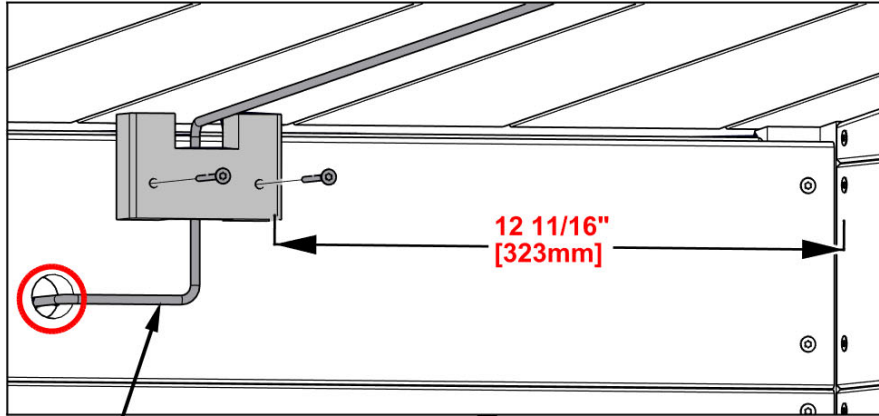

CORD FROM PREVIOUS STEP

ENSURE NOTCH IS ORIENTED TO TOP

1429 (x4)
SCREW - 2"

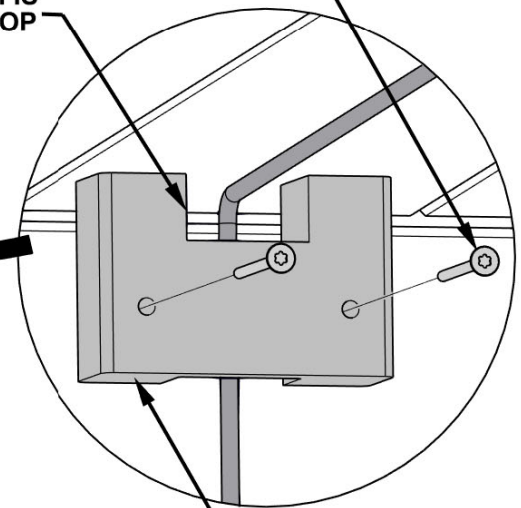
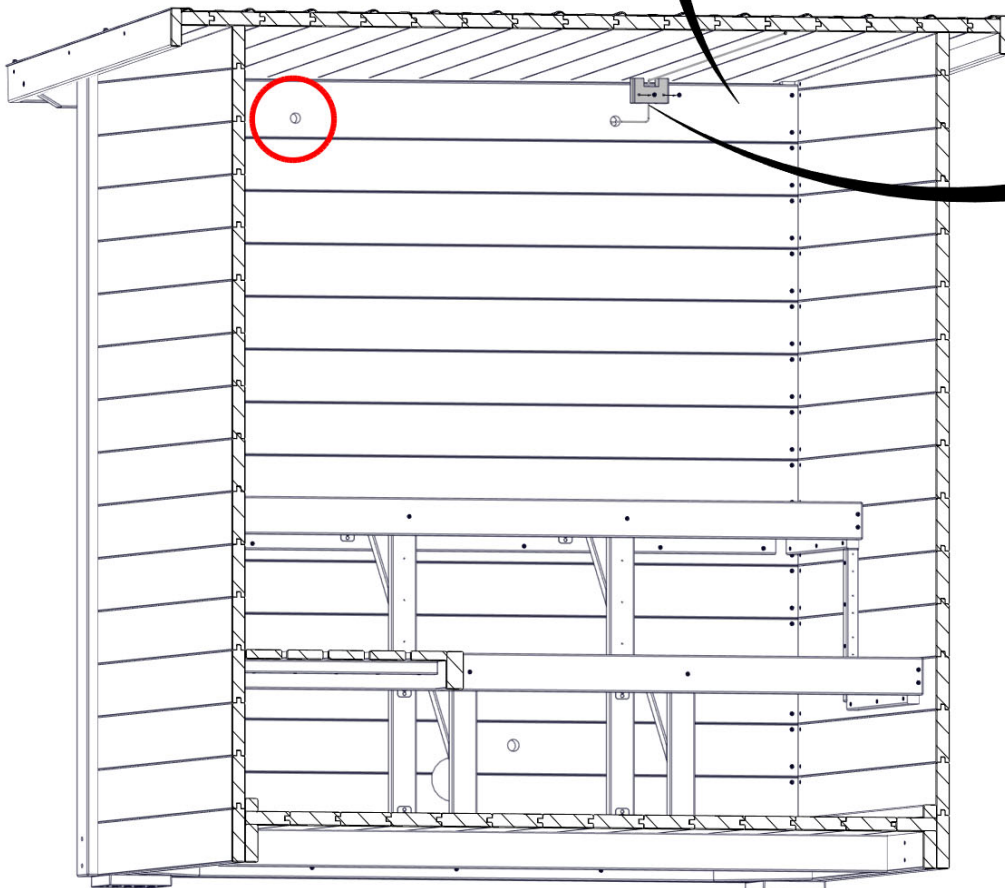

OG11 (x1)
WIREWAY BOARD

FRONT OF SAUNA HIDDEN
FOR DETAIL

STEP 64 - TRIM ASSEMBLY

QTY	PART NUMBER	DESCRIPTION
8	H101429	SCREW TFH 8X2 SS-BLK

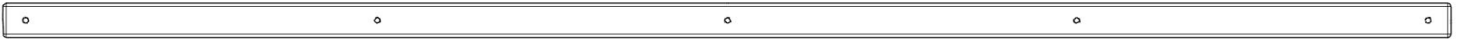

OO18 TRIM - W4L22731
(x1) 1 3/16"x1 3/16"x49 13/16" (30x30x1266)



OO09 TRIM - W4L22496
(x1) 1 3/16"x1 3/16"x12 5/8" (30x30x321)

- POSITION TRIM AGAINST WIREWAY BOARD AND CEILING AND ATTACH AS SHOWN.

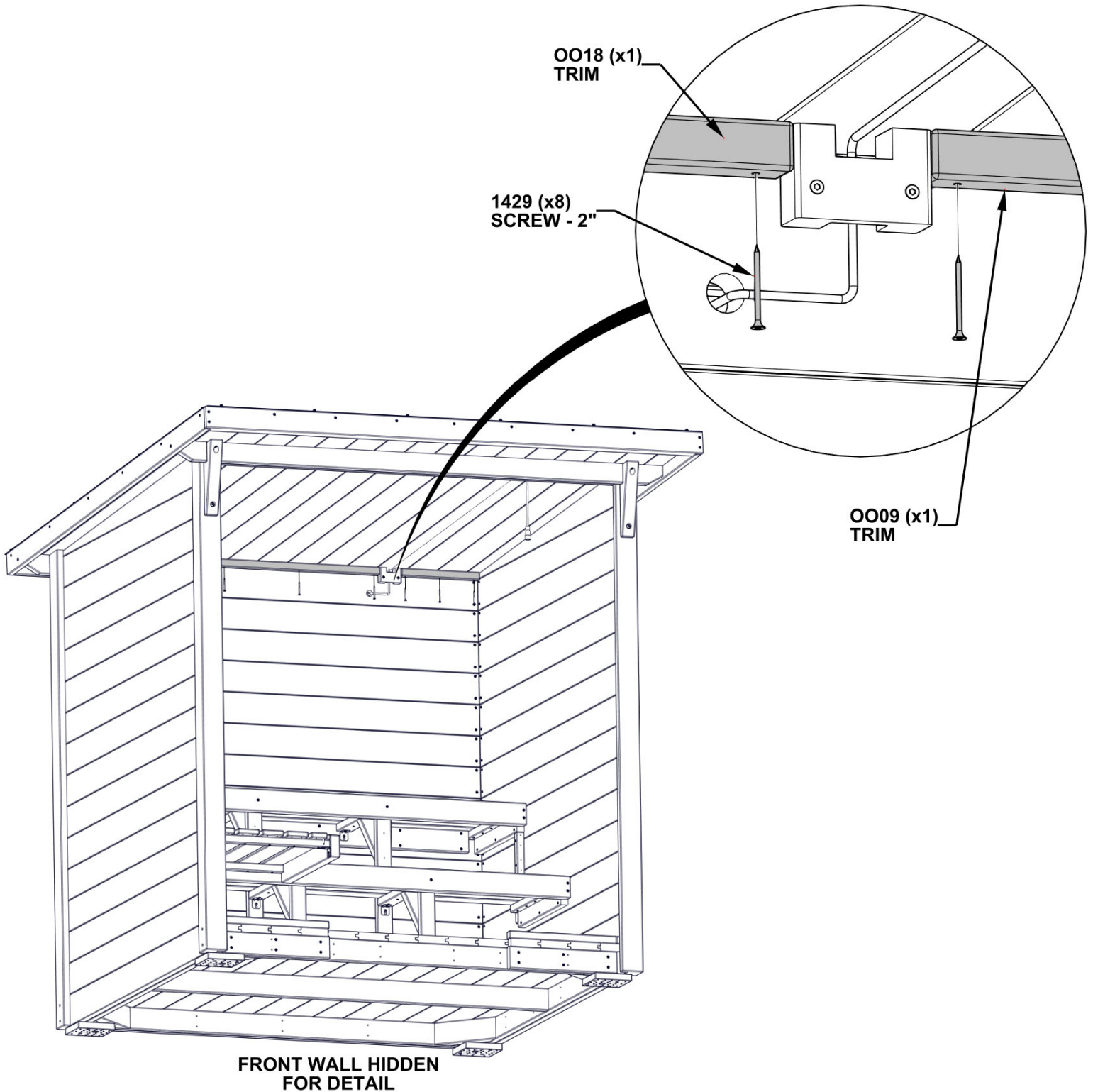

STEP 65 - LIGHT ASSEMBLY

QTY	PART NUMBER	DESCRIPTION
2	H101437	SCREW TWH 8x5/8 SS-BLK

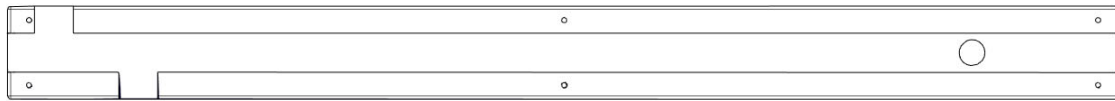

OG13 LIGHT MOUNT - W4L22494
(x1) 30x3 3/8"x40 9/16" (30x86x1030)

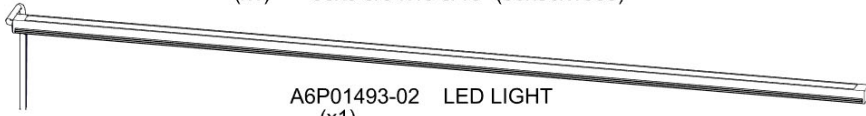

A6P01493-02 LED LIGHT
(x1)

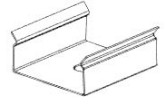

A6P01493-04 LIGHT CLIP
(x2)

- ATTACH LIGHT CLIPS IN APPROXIMATE LOCATIONS SHOWN.
- USE DIMENSIONS TO LOCATE CLIPS.
- SNAP LED LIGHT INTO CLIPS.

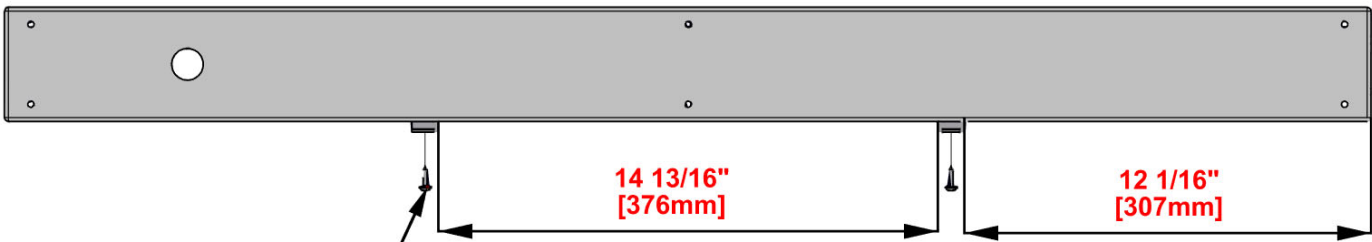

1437 (x2)
SCREW - 5/8"

OG13 (x1)
LIGHT MOUNT

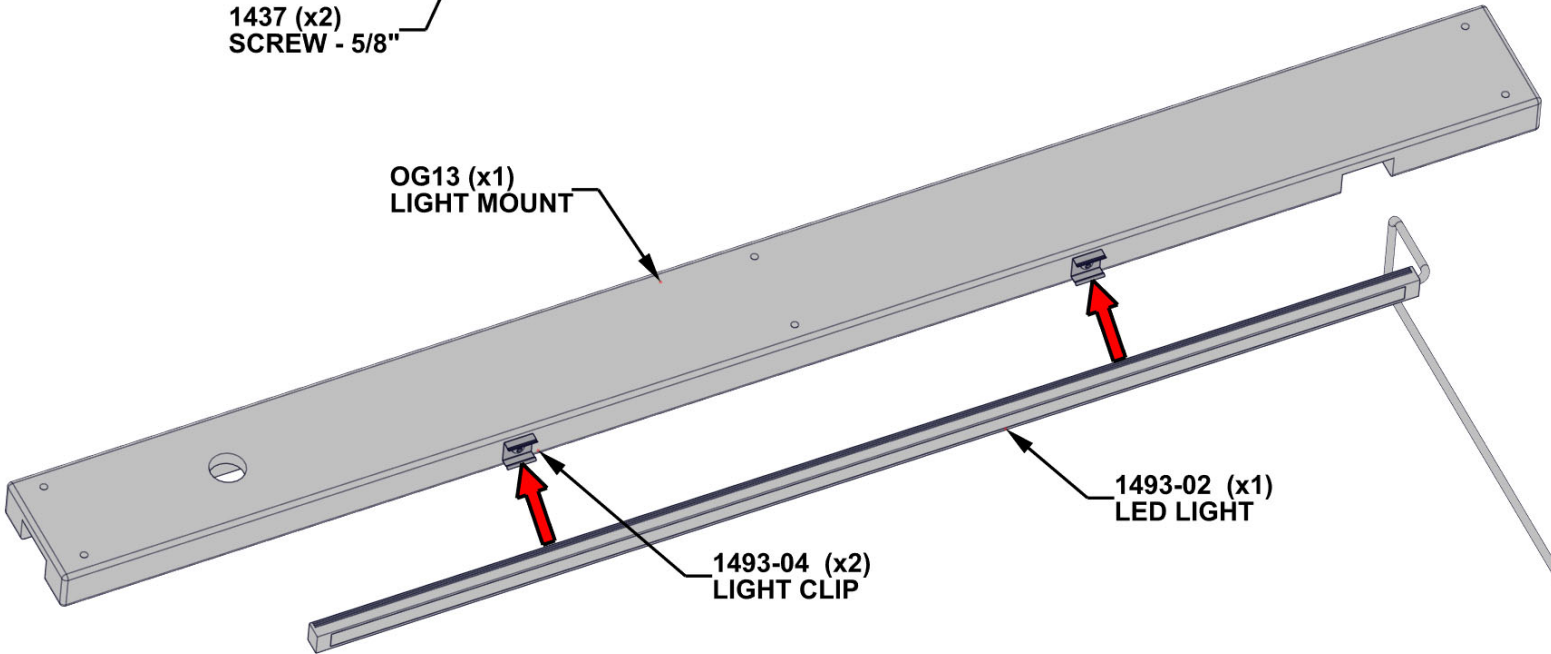

1493-02 (x1)
LED LIGHT

1493-04 (x2)
LIGHT CLIP

STEP 66 - LIGHT ASSEMBLY

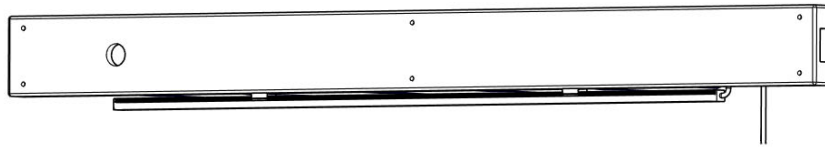

LED LIGHT MOUNT ASSEMBLY - STEP 64
(x1)

- RUN WIRE FROM LED LIGHT THROUGH THE LED LIGHT MOUNT ASSEMBLY NOTCH LOCATED AT THE BOTTOM AND THROUGH THE HOLE IN THE BACK WALL.

RUN CORD THROUGH NOTCH IN BOTTOM OF LED LIGHT MOUNT ASSEMBLY

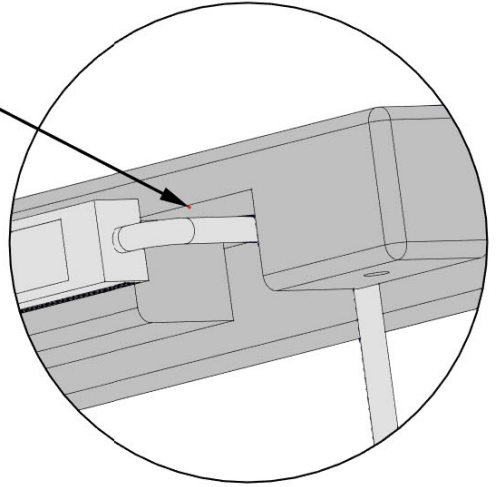

ALIGN NOTCH IN LIGHT MOUNT ASSEMBLY WITH NOTCH ON PREVIOUSLY MOUNTED WIREWAY BOARD

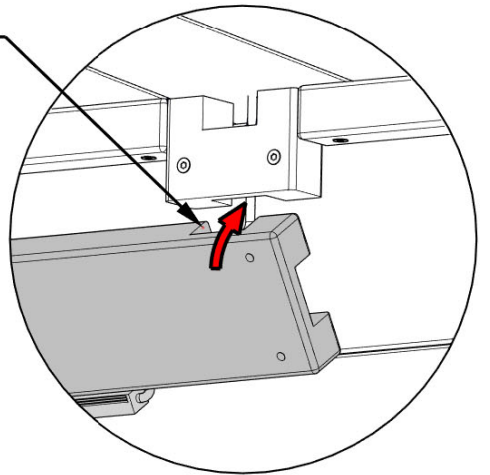

WIREWAY STEP 62

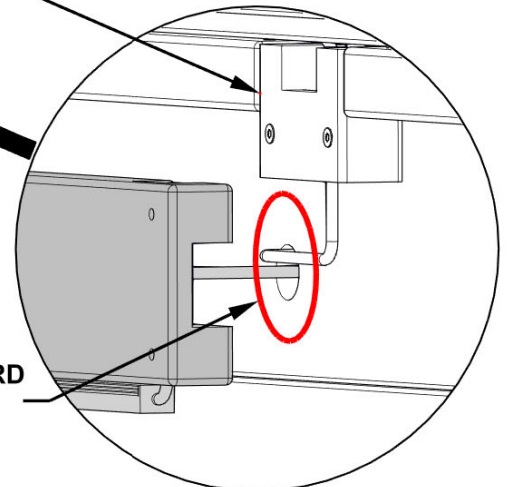

BACK

RUN LED LIGHT CORD THROUGH HOLE IN BACK WALL

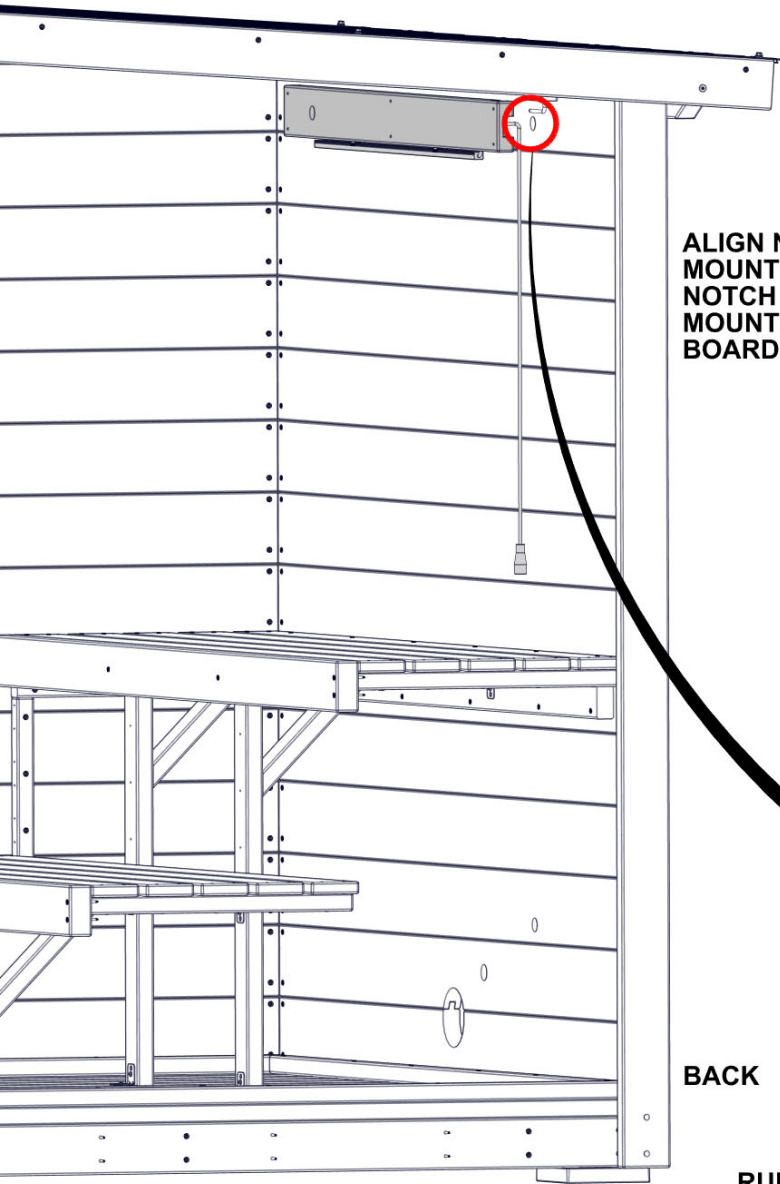

RIGHT SIDE WALL HIDDEN FOR DETAIL

STEP 67 - LIGHT ASSEMBLY

QTY	PART NUMBER	DESCRIPTION
6	H101429	SCREW TFH 8X2 SS-BLK

- ALIGN HOLE IN LED LIGHT MOUNT ASSEMBLY FROM STEP 65 TO THE HOLE PROVIDED IN THE WALL.
- ENSURE THE NOTCH IN THE LED LIGHT MOUNT ASSEMBLY ALIGNS WITH THE WIREWAY INSTALLED IN STEP 63.
- POSITION LED LIGHT MOUNT ASSEMBLY SO IT IS FLUSH WITH THE BOTTOM OF THE WIREWAY FROM STEP 63.
- CHECK THAT LED LIGHT MOUNT ASSEMBLY IS LEVEL AND ATTACH AS SHOWN.
- TAKE CAUTION WHEN ATTACHING SCREWS TO PREVENT PINCHING OR PENETRATING CORDS.

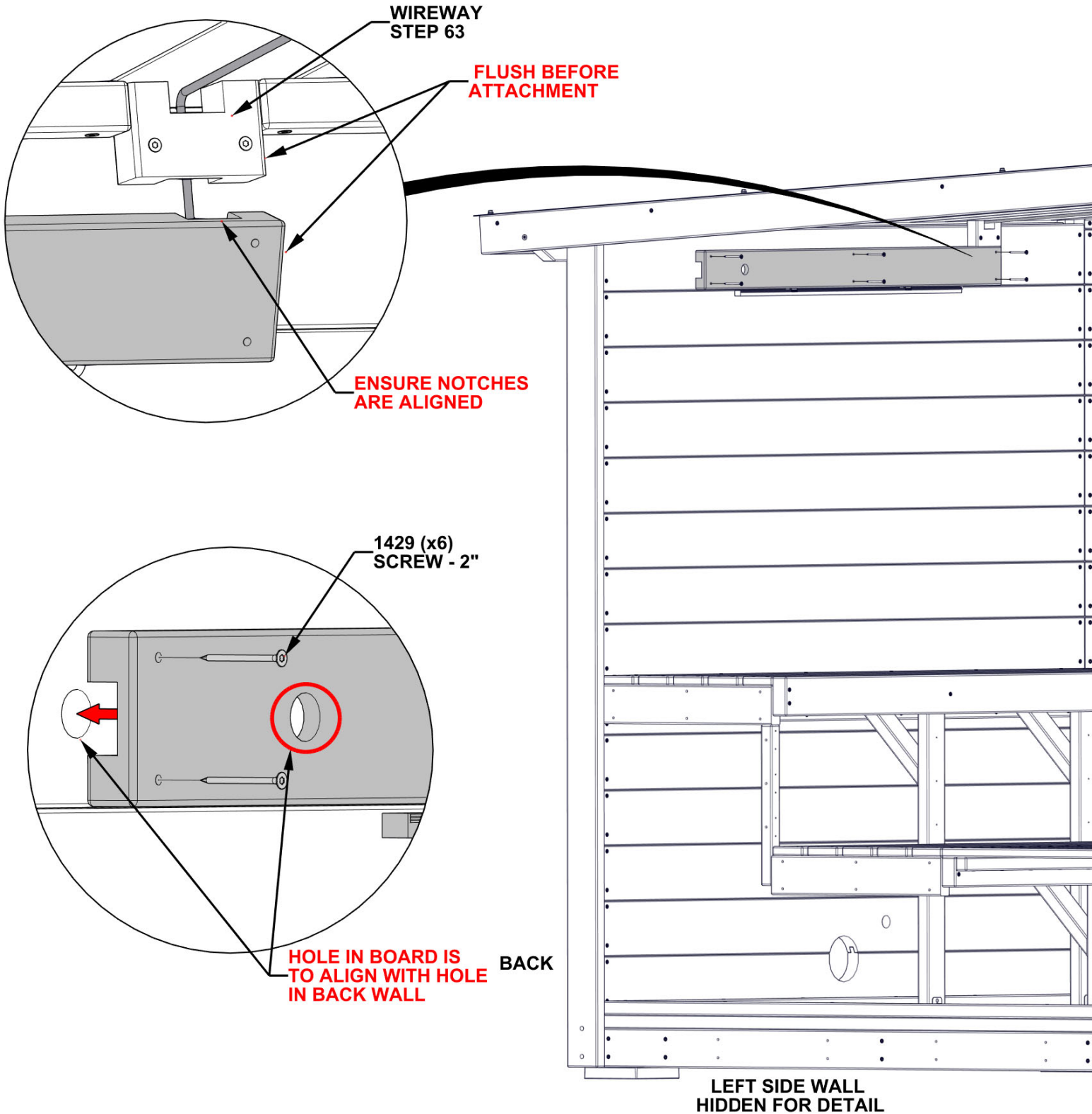

STEP 68 - WIREWAY ASSEMBLY

QTY	PART NUMBER	DESCRIPTION
10	H101429	SCREW TFH 8X2 SS-BLK

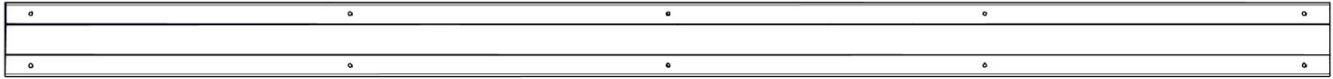

OG10 WIREWAY BOARD - W4L22387
(x1) 1 3/16"x3 3/8"x60 3/4" (30x86x1543)

- ENSURE CORD RESTS IN GROOVE IN THE TOP OF THE WIREWAY BOARD AS BOARD IS PUT INTO POSITION.
- ALIGN WITH PREVIOUSLY INSTALLED WIREWAY BOARDS ON THE FRONT AND BACK WALLS.
- ATTACH AS SHOWN.
- TAKE CAUTION WHEN ATTACHING SCREWS TO PREVENT PINCHING OR PENETRATING CORDS.

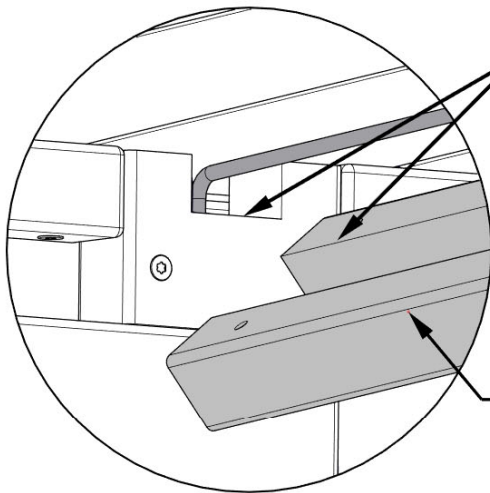

ENSURE THAT NOTCHES ARE ALIGNED

OG10 (x1)
WIREWAY BOARD

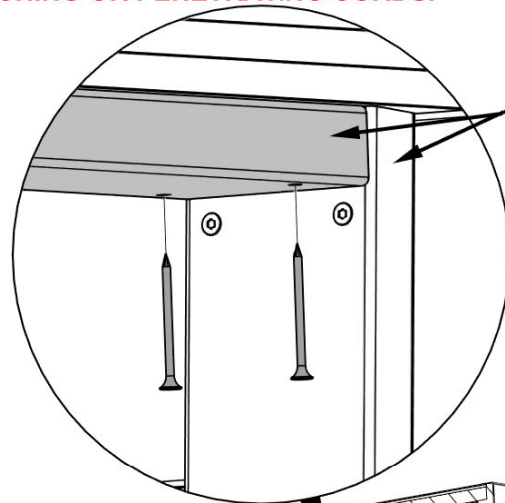

FLUSH

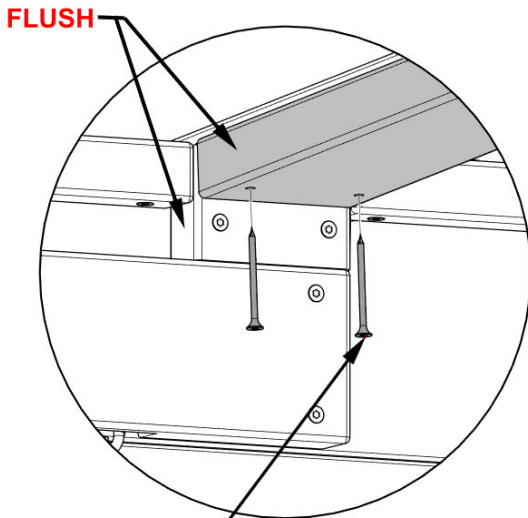

FLUSH

1429 (x10)
SCREW - 2"

LEFT SIDE WALL
HIDDEN FOR DETAIL

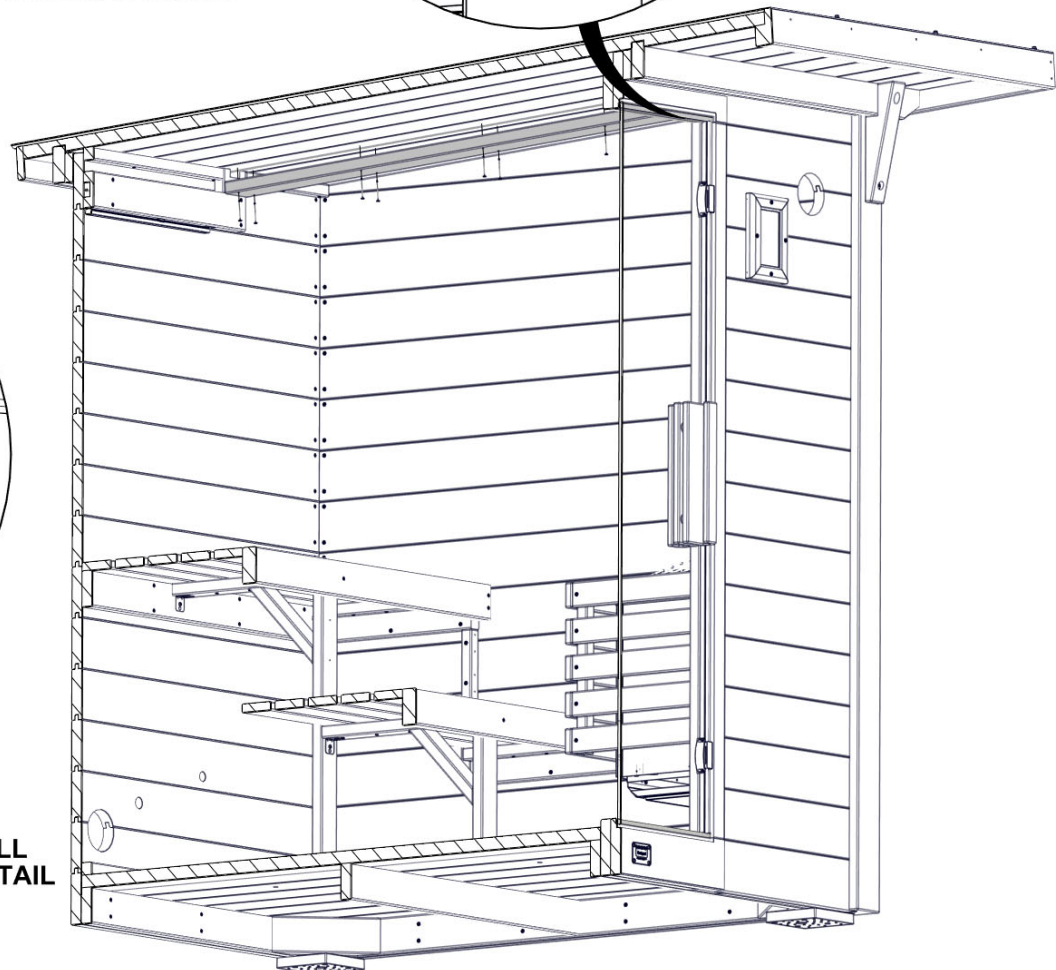

STEP 69 - TEMPERATURE SENSOR

QTY	PART NUMBER	DESCRIPTION
2	H101440	SCREW TWH 8x1 SS-BLK

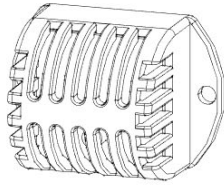

A4M05590-08 TEMPERATURE SENSOR (x1)

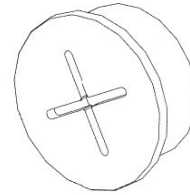

A6P01467 25mm SILICONE GROMMET (x1)

- RUN CORD FOR TEMPERATURE SENSOR THROUGH HOLE, AND CAREFULLY LET HANG UNTIL IT IS ATTACHED LATER.
- SLIDE GROMMET OVER CORDS AND INSERT INTO THE HOLE CUTOUT IN BACK WALL.

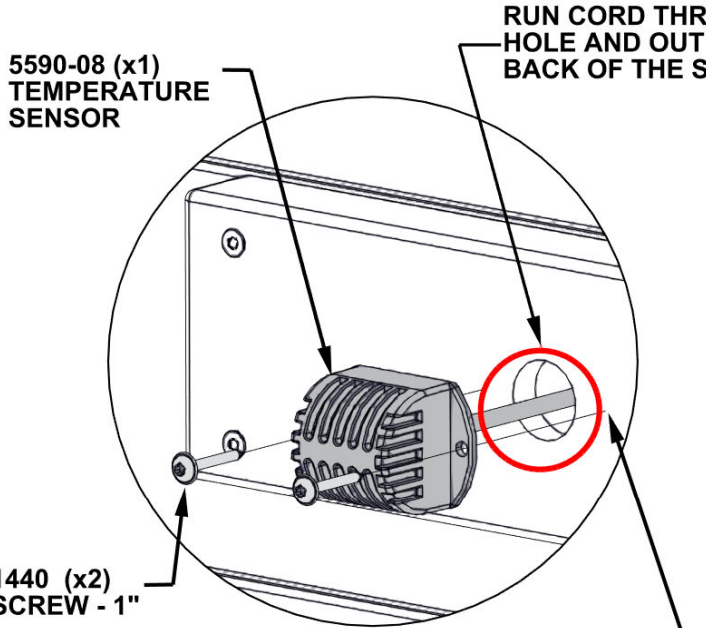

USE TEMPERATURE SENSOR AND MARK SCREW HOLE POSITIONS. PRE-DRILL USING 1/8" [3mm] DRILL BIT.

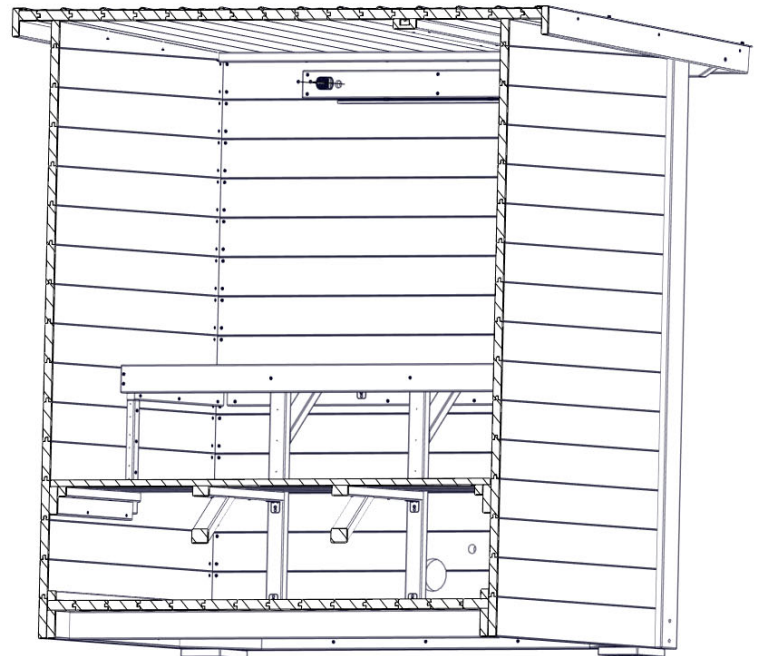

FRONT OF SAUNA HIDDEN FOR DETAIL

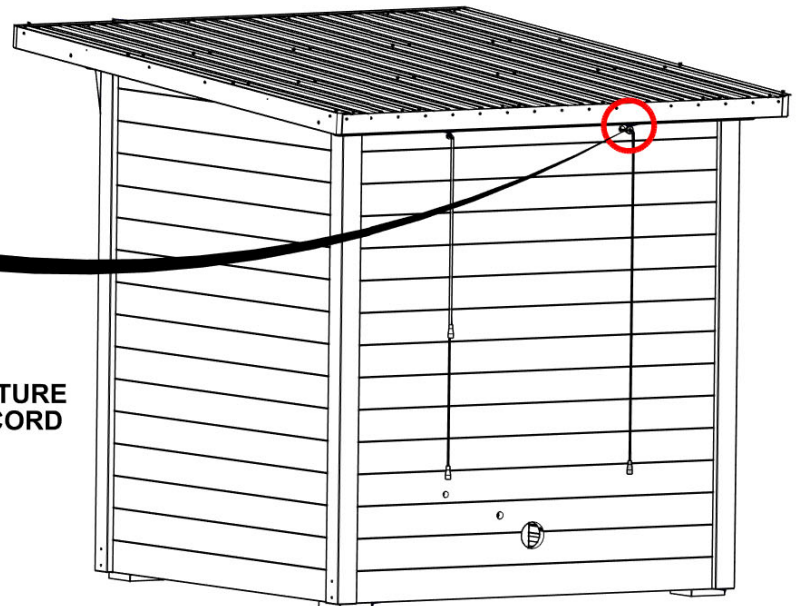
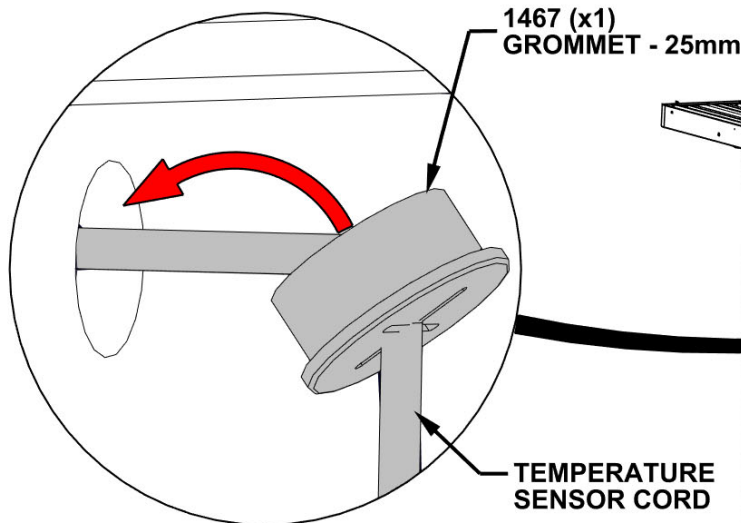

STEP 70 - LIGHT ASSEMBLY

QTY	PART NUMBER	DESCRIPTION
2	H101437	SCREW TWH 8x5/8 SS-BLK

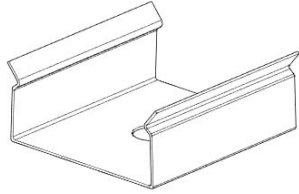

A6P01493-04 LIGHT CLIP
(x2)

- ATTACH LIGHT CLIPS IN APPROXIMATE LOCATION SHOWN.
- USE DIMENSIONS GIVEN BETWEEN LIGHT CLIPS AND CENTER ON BOARDS.

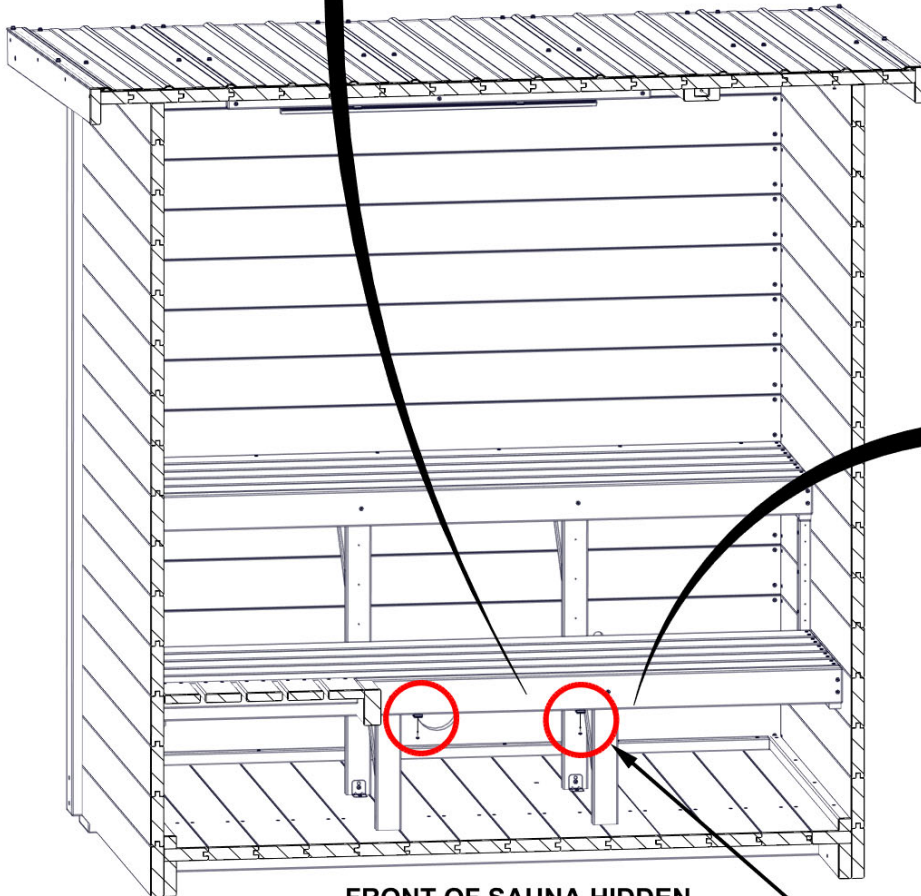
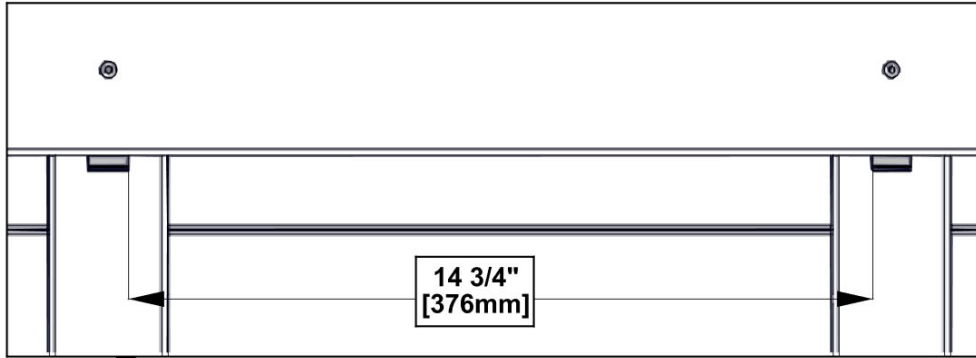

FRONT OF SAUNA HIDDEN FOR DETAIL

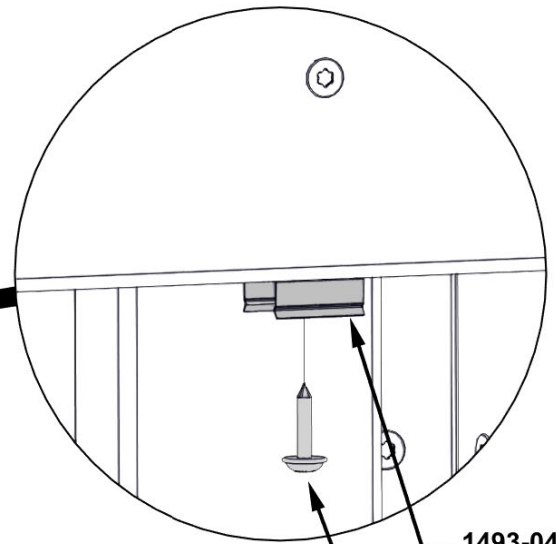

1493-04 (x2)
LIGHT CLIP

1437 (x2)
SCREW - 5/8"

ATTACH LIGHT CLIPS TO
BOTTOM OF BENCH TRIM

STEP 71 - LIGHT ASSEMBLY

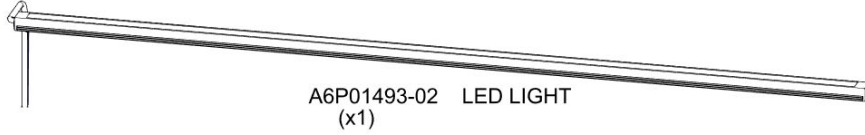

- BEFORE CLIPPING LIGHT INTO PLACE, RUN CORDS THROUGH HOLE IN BACK WALL.
- SNAP LED LIGHT INTO LIGHT CLIPS.

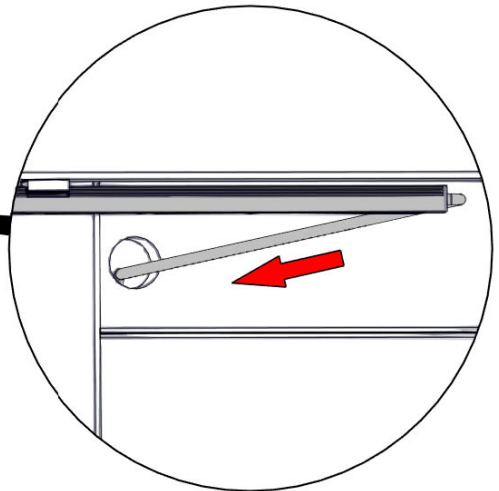
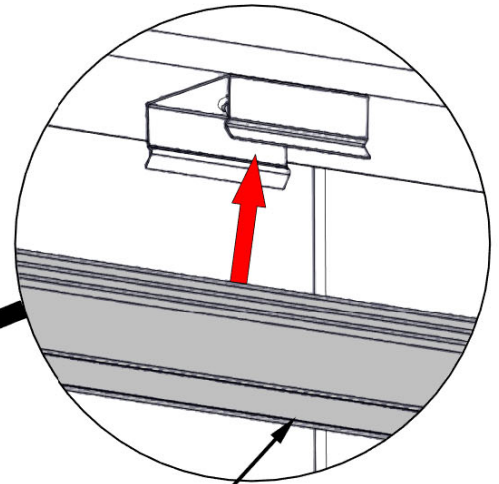
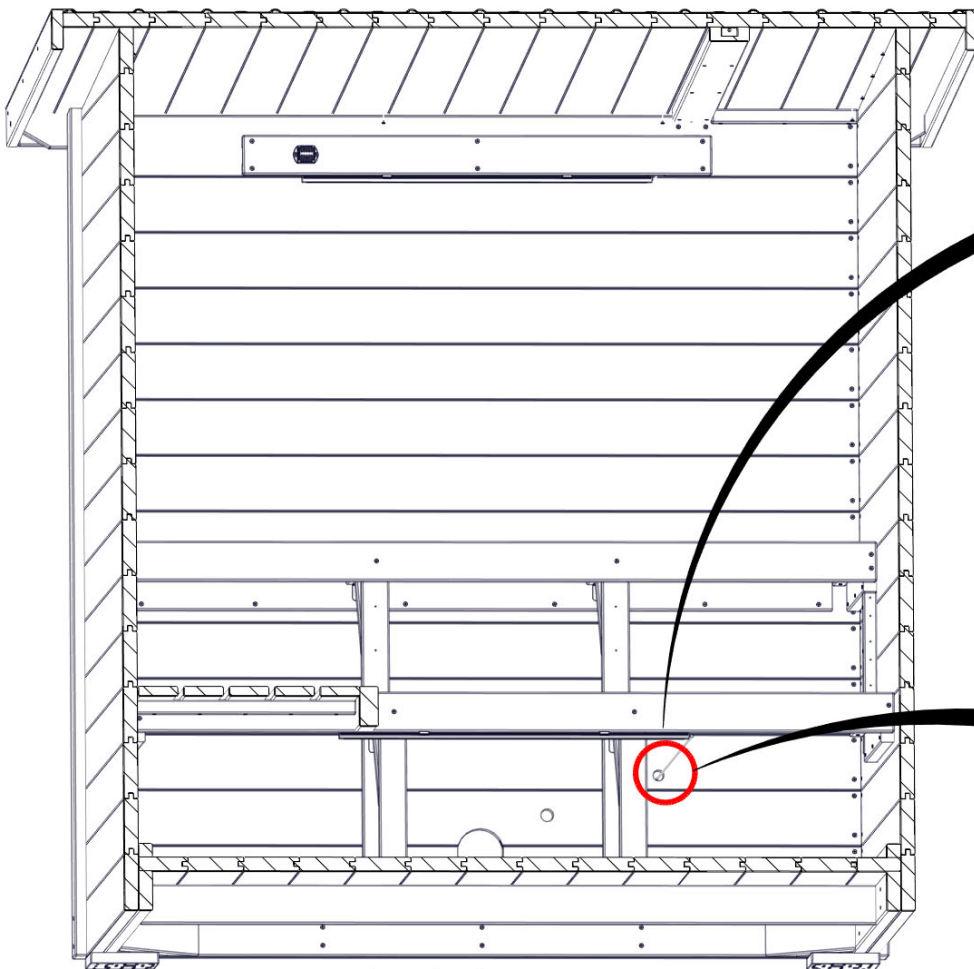

STEP 72 - BENCH ASSEMBLY

QTY	PART NUMBER	DESCRIPTION
18	H101428	SCREW TFH 8X1 3/4 SS-BLK



NG01 SLAT - W4L21949
 (x3) 13/16"x3 3/8"x65 3/4" (20x86x1670)

- ALIGN THROUGH HOLES IN SLATS WITH PILOT HOLES IN CLEATS AND UPRIGHTS.

NG01 (x3)
 SLAT

1428 (x18)
 SCREW - 1 3/4"

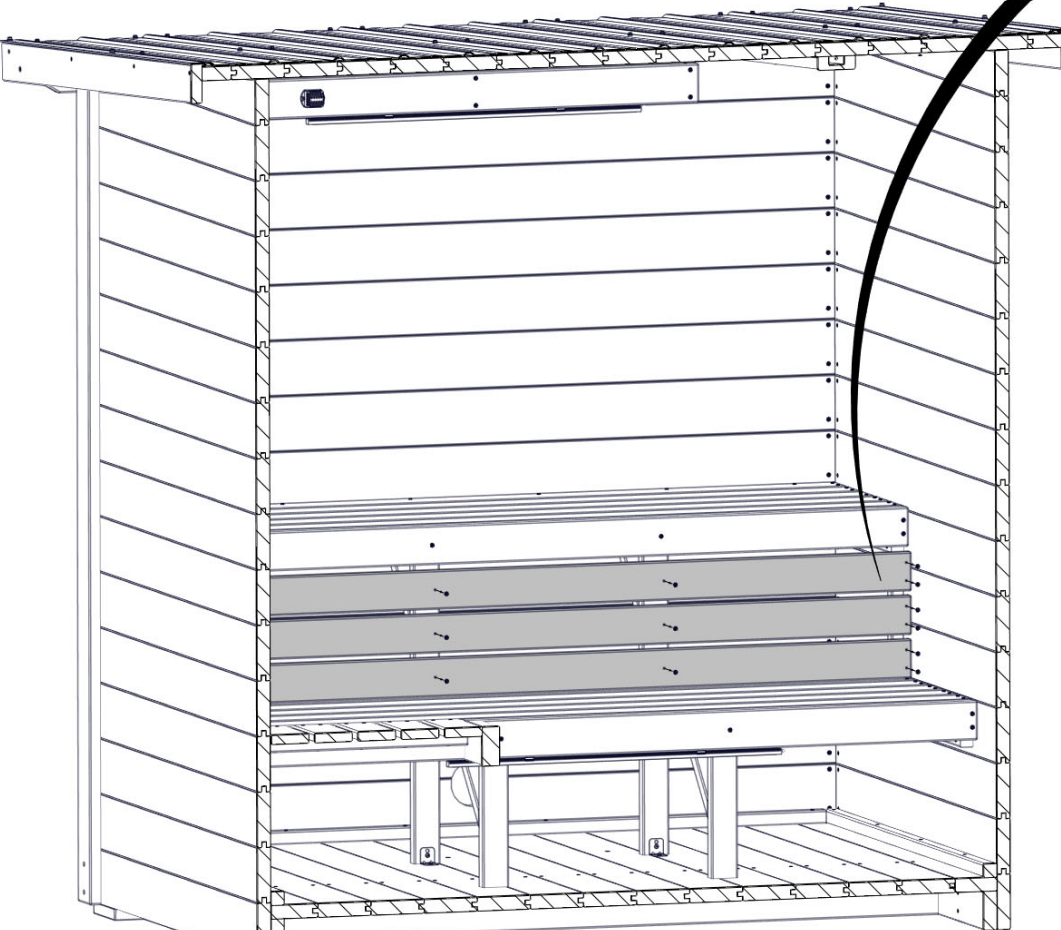
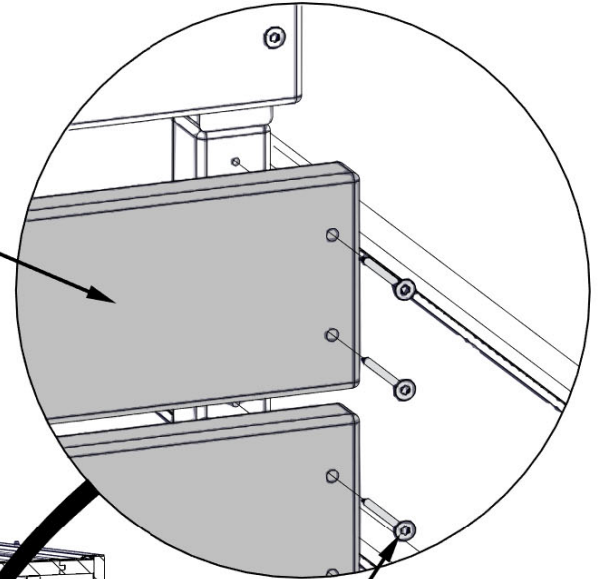

FRONT OF SAUNA HIDDEN
 FOR DETAIL

STEP 73 - GROMMET INSTALLATION

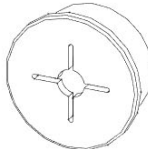

A6P01467 SILICONE GROMMET 25mm
(x2)

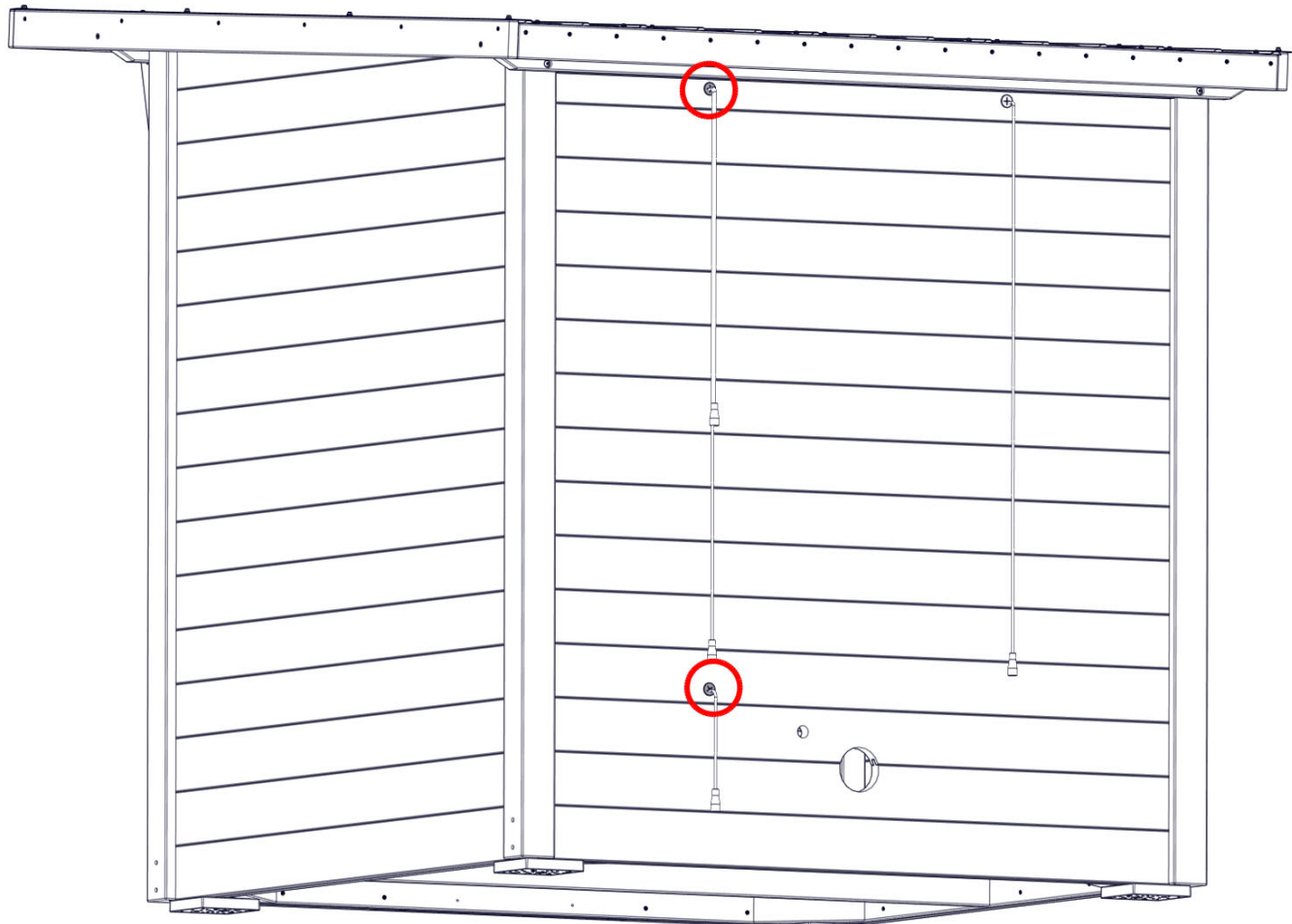
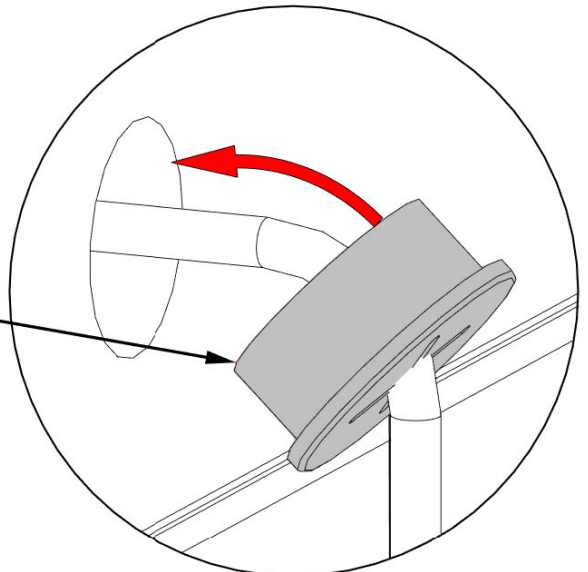

STEP 74 - CONTROL PANEL

QTY	PART NUMBER	DESCRIPTION
3	H101440	SCREW TWH 8x1 SS-BLK

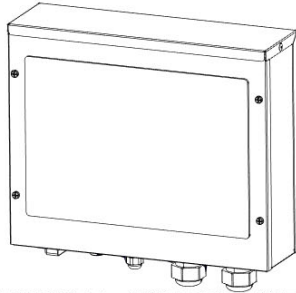

A4M05590-01 CONTROL PANEL BOX
(x1)

- REMOVE COVER PLATE FROM CONTROL PANEL BOX.
- USE DIMENSIONS TO LOCATE CONTROL PANEL BOX AND ATTACH AS SHOWN.
- REATTACH COVER PLATE.

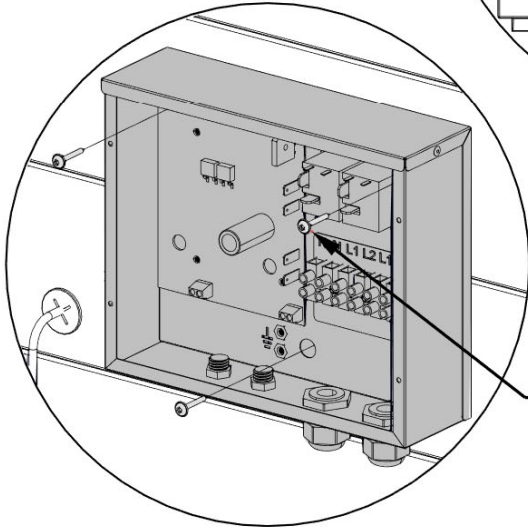
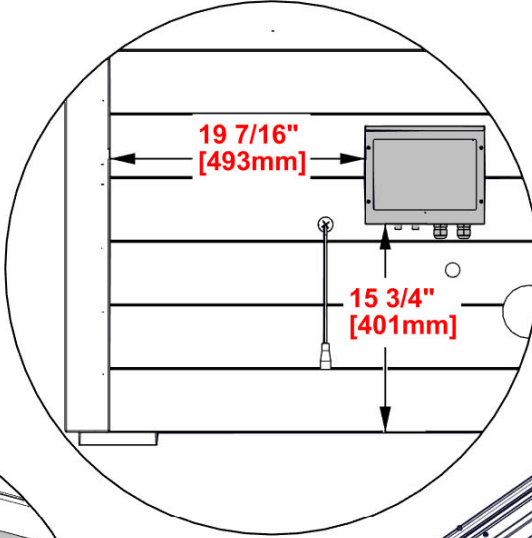

1440 (x3)
SCREW - 1"

COVER PLATE

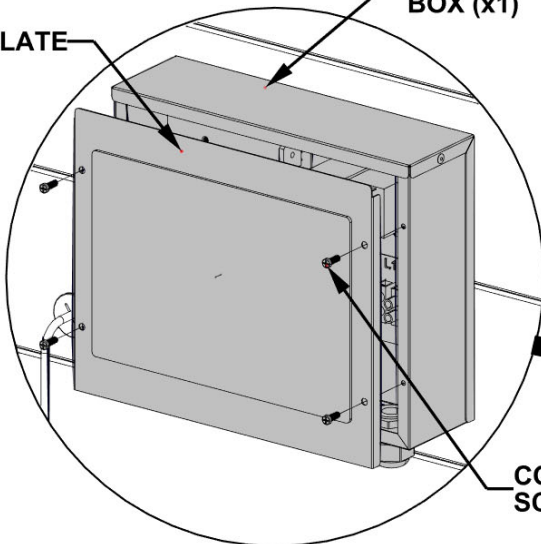

CONTROL PANEL
BOX (x1)

COVER PLATE
SCREWS

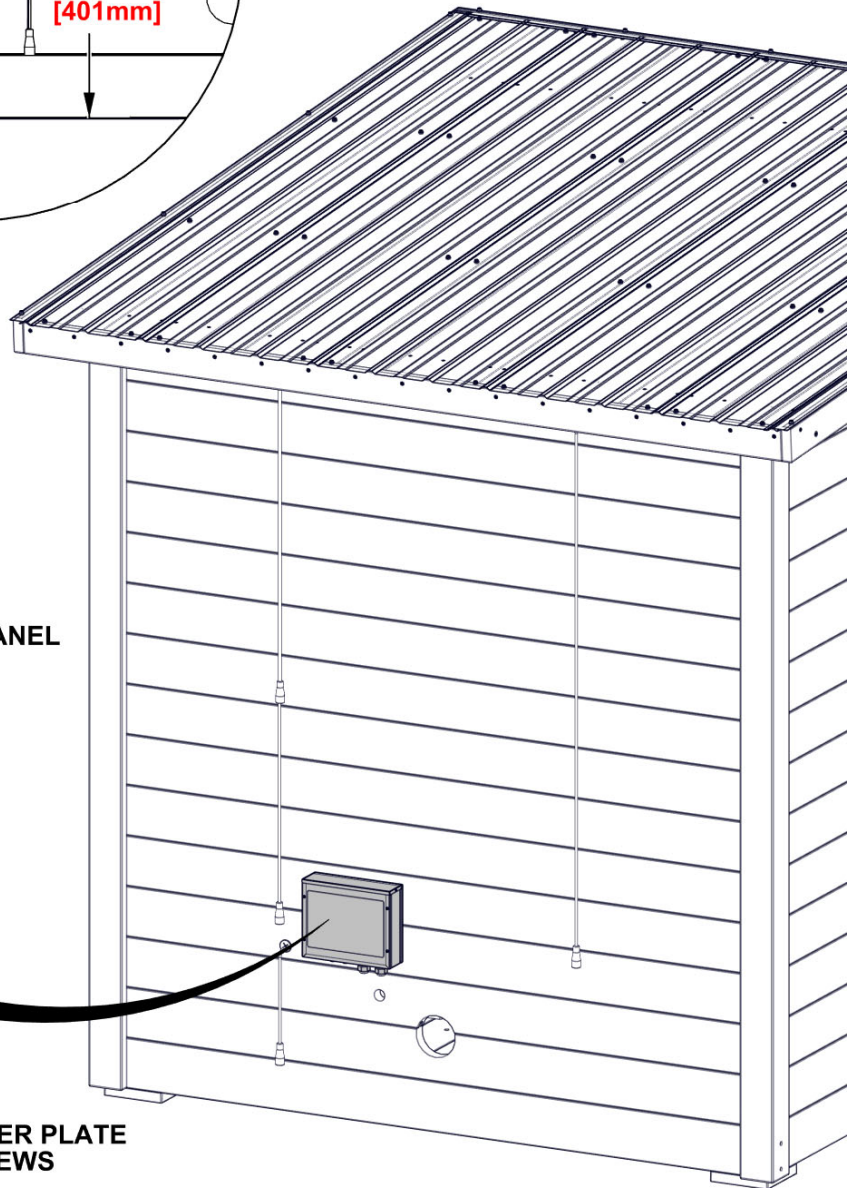

STEP 75 - ELECTRICAL

QTY	PART NUMBER	DESCRIPTION
8	H101409	SCREW PPH 4x1/2 BLK
6	H101440	SCREW TWH 8x1 SS-BLK

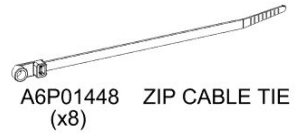
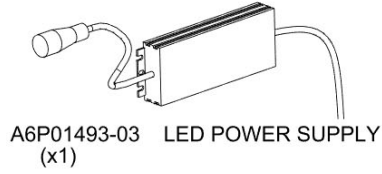
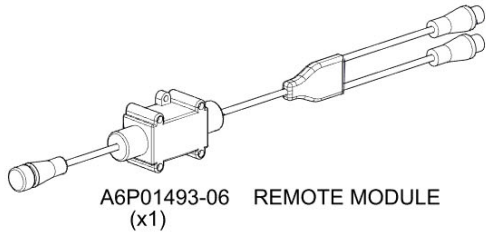

- LOCATE REMOTE MODULE AND POWER SUPPLY IN THE APPROXIMATE LOCATIONS.
- ENSURE REMOTE MODULE AND POWER SUPPLY ARE ORIENTED HORIZONTALLY WHEN ATTACHING.
- USE ZIP TIES WHERE NEEDED TO ATTACH AND ORGANIZE CORDS.

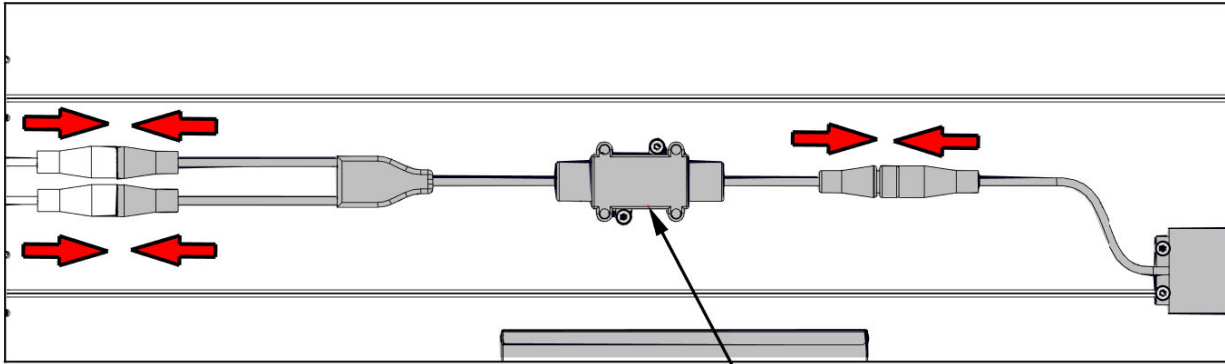

LED POWER SUPPLY (x1) REMOTE MODULE (x1)

1440 (x6) SCREW - 1"

1409 (x8) SCREW - 1/2"

1448 (x8) ZIP CABLE TIE

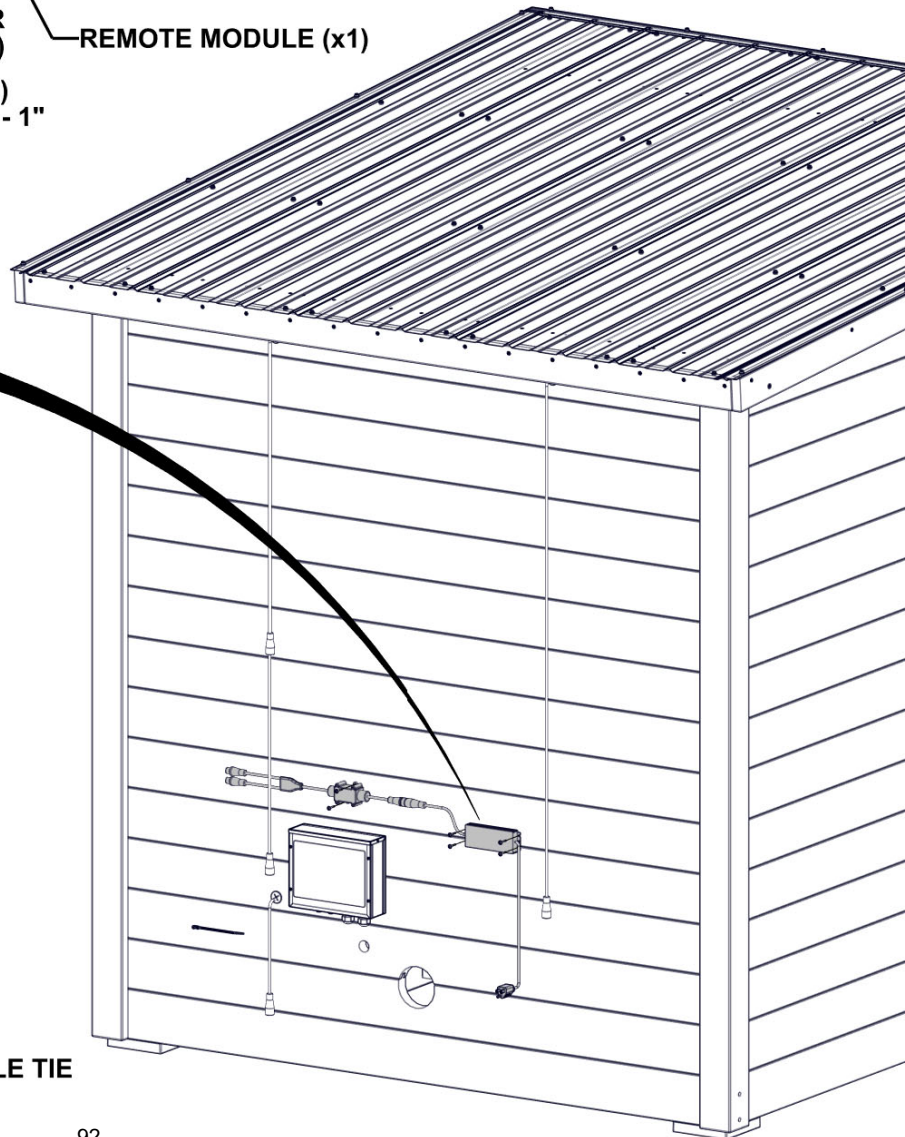

STEP 76 - VENT ASSEMBLY

QTY	PART NUMBER	DESCRIPTION
3	H101424	SCREW TFH 8X1 SS-BLK
4	H101438	SCREW TWH 8x3/4 SS-BLK

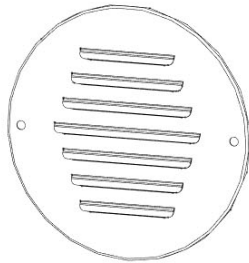

A4M05285 VENT
(x2)

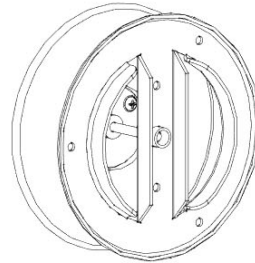

A4M05592 VENT COVER
(x1)

- BEFORE ATTACHING VENT COVER, UNSCREW ADJUSTABLE VENT COVER FROM VENT BASE INSERT.
- ONCE VENT BASE INSERT IS ATTACHED, SCREW ADJUSTABLE VENT COVER BACK IN.

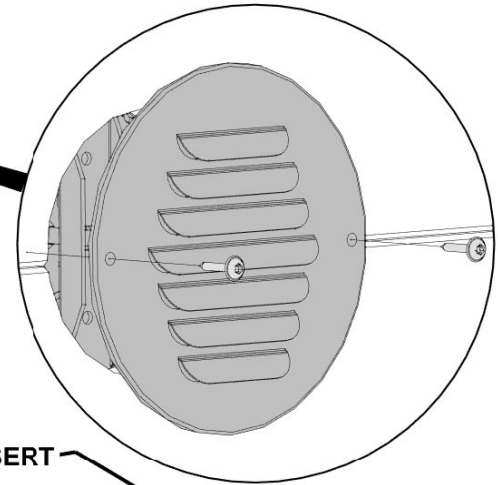
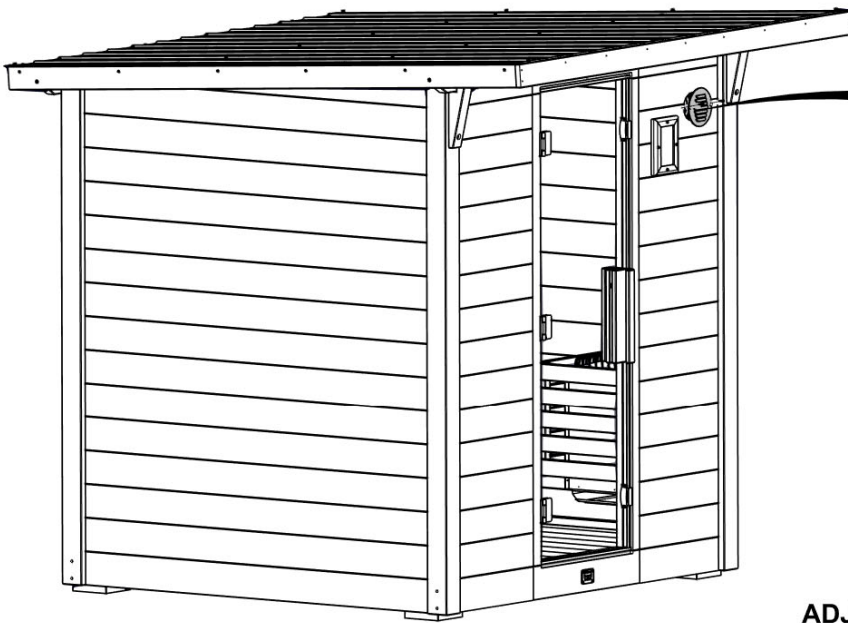

5592 (x1)
VENT INSERT
BASE

1424 (x3)
SCREW - 1"

ADJUSTABLE
VENT COVER

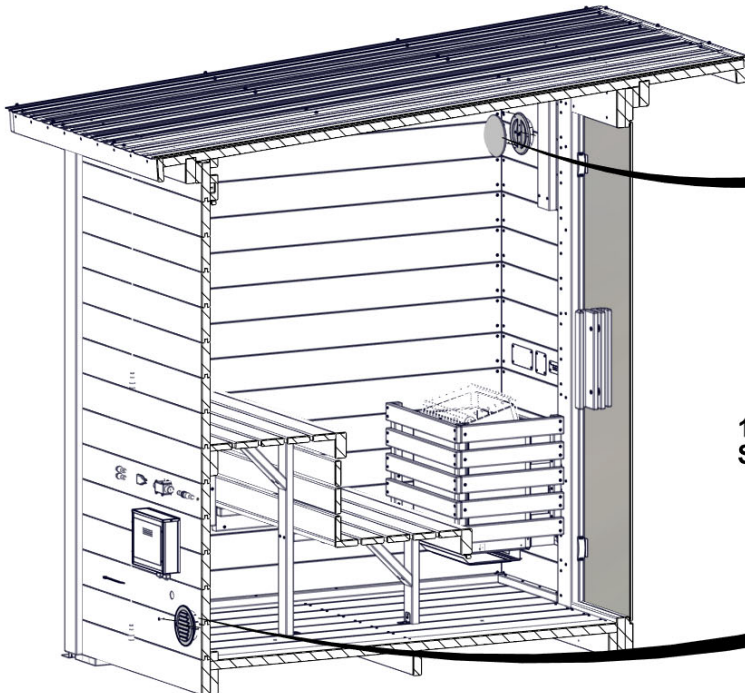
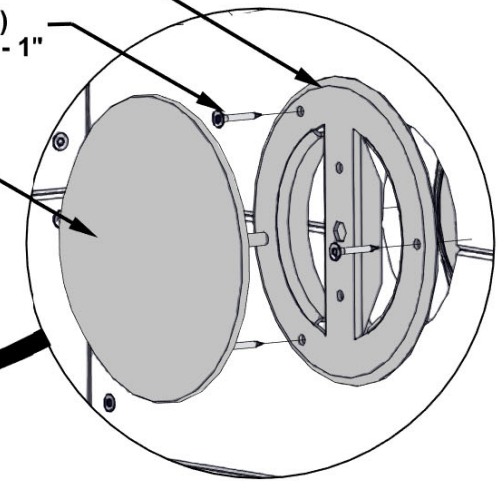

5285 (x2)
VENT COVER

1438 (x4)
SCREW - 3/4"

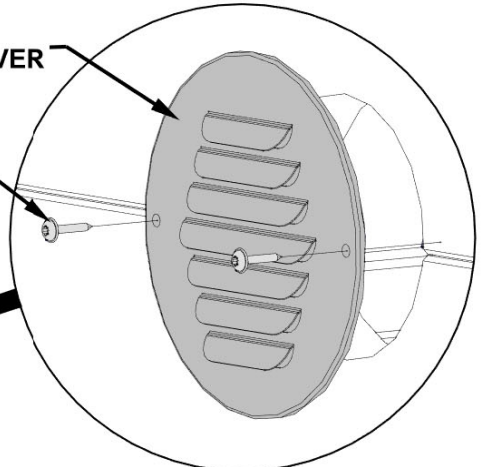

STEP 77 - TOWEL HANGER

QTY	PART NUMBER	DESCRIPTION
4	H101423	SCREW TFH 8X7/8 SS-BLK

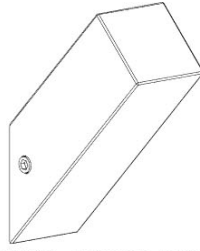

A4M05672 TOWEL HANGER
(x2)

- INSTALL TOWEL HANGERS AT ANY DESIRE LOCATION ON THE RIGHT SIDE.
- HOWEVER, DO NOT INSTALL SCREWS AT THE SEAMS OF THE PANEL BOARDS.

5672 (x2)
MOUNTING
BRACKET

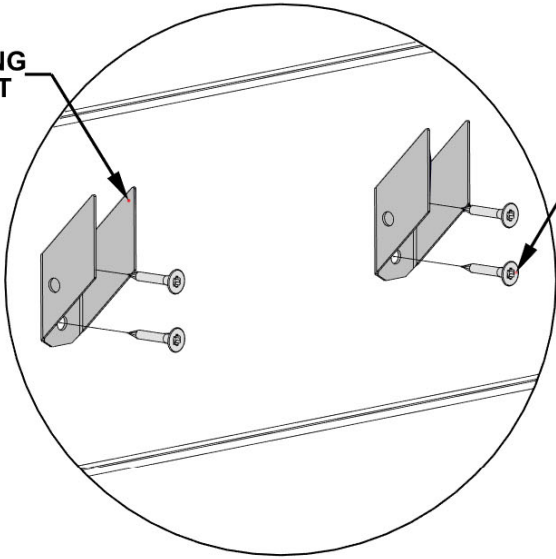

5672 (x2)
TOWEL HANGER

1423 (x4)
SCREW - 7/8"

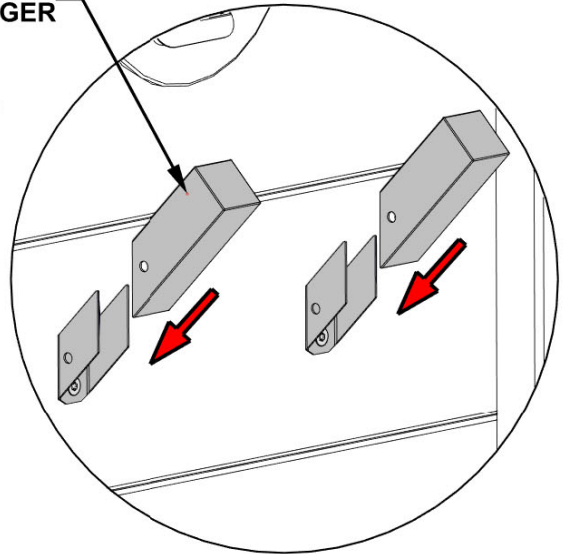

5672 (x2)
SET SCREW

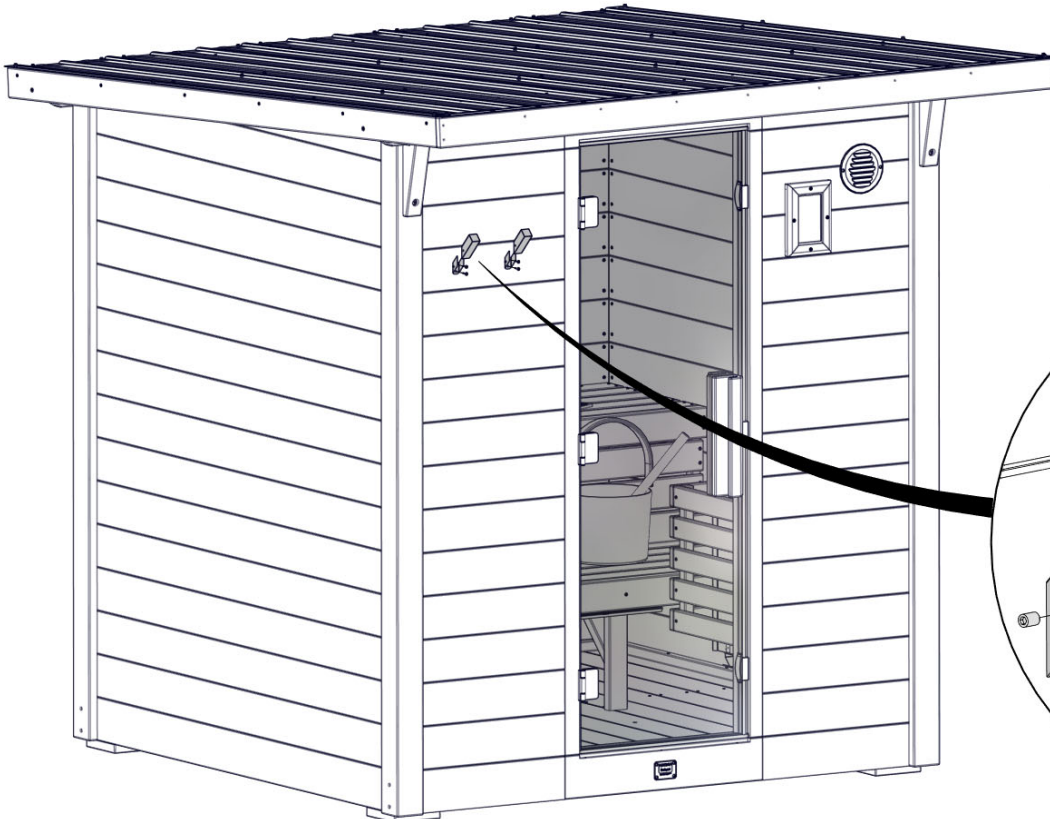
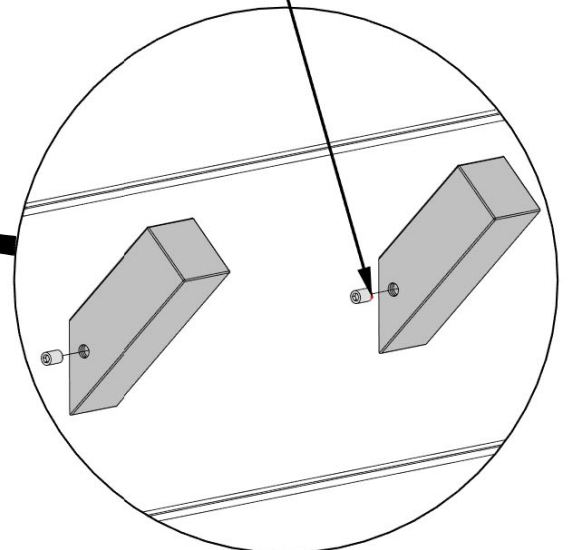

STEP 78 - THERMOMETER INSTALLATION

QTY	PART NUMBER	DESCRIPTION
1	H101424	SCREW TFH 8X1 SS-BLK

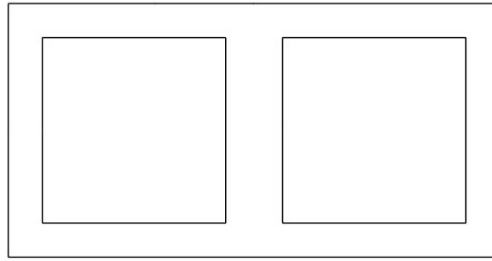

T01 THERMOMETER - W4L21965
(x1)

- INSERT SCREW INTO SIDE WALL IN APPROXIMATE LOCATION SHOWN TO HANG THERMOMETER.

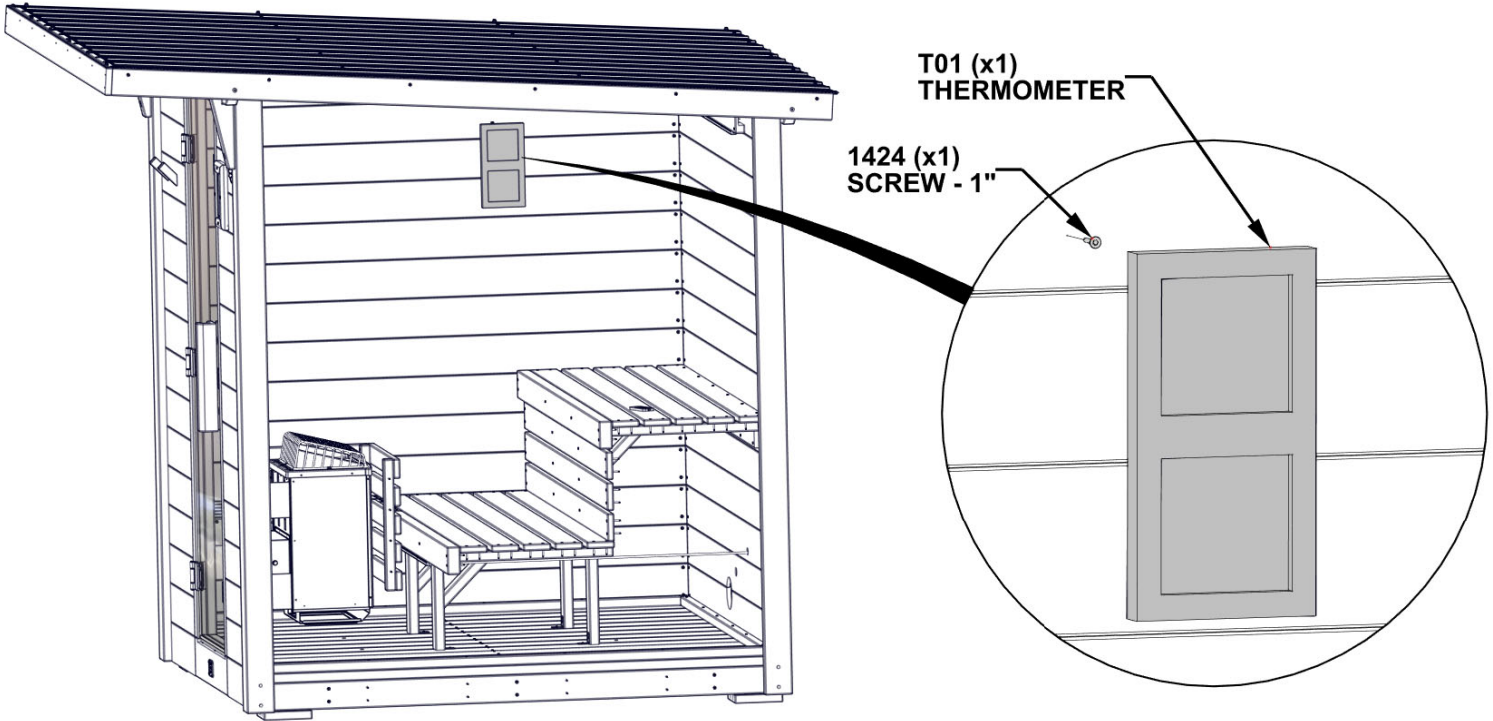

RIGHT SIDE HIDDEN
FOR DETAIL

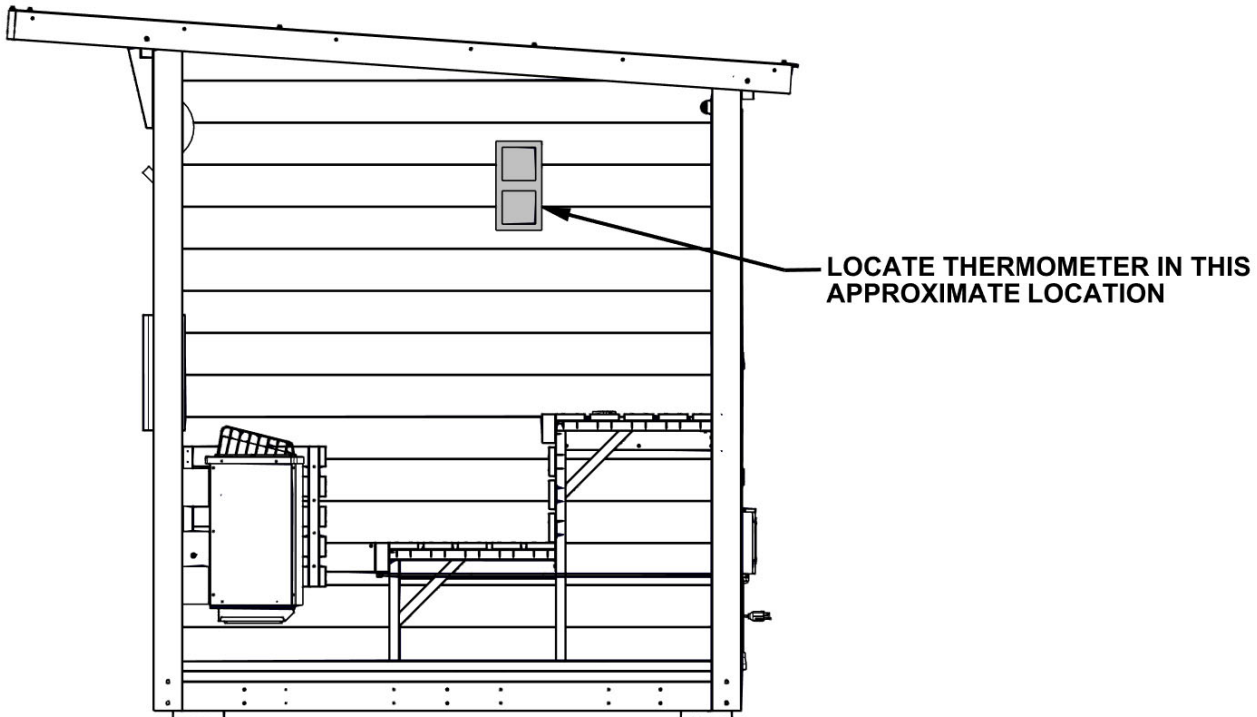

STEP 79 - TRIM ASSEMBLY

QTY	PART NUMBER	DESCRIPTION
8	H101429	SCREW TFH 8X2 SS-BLK



OO08 TRIM - W4L22495
(x1) 1 3/16"x1 3/16"x18 7/16" (30x30x469)

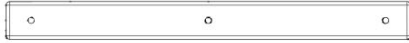

OO09 TRIM - W4L22496
(x1) 1 3/16"x1 3/16"x12 5/8" (30x30x321)



OO16 TRIM - W4L22415
(x1) 1 3/16"x1 3/16"x2 3/8" (30x30x60)

- POSITION OO16 AND OO09 AS SHOWN AND FLUSH AGAINST THE WIREWAY BOARDS.
- POSITION OO08 AS SHOWN AND FLUSH AGAINST THE DOOR FRAME.
- ATTACH AS SHOWN.

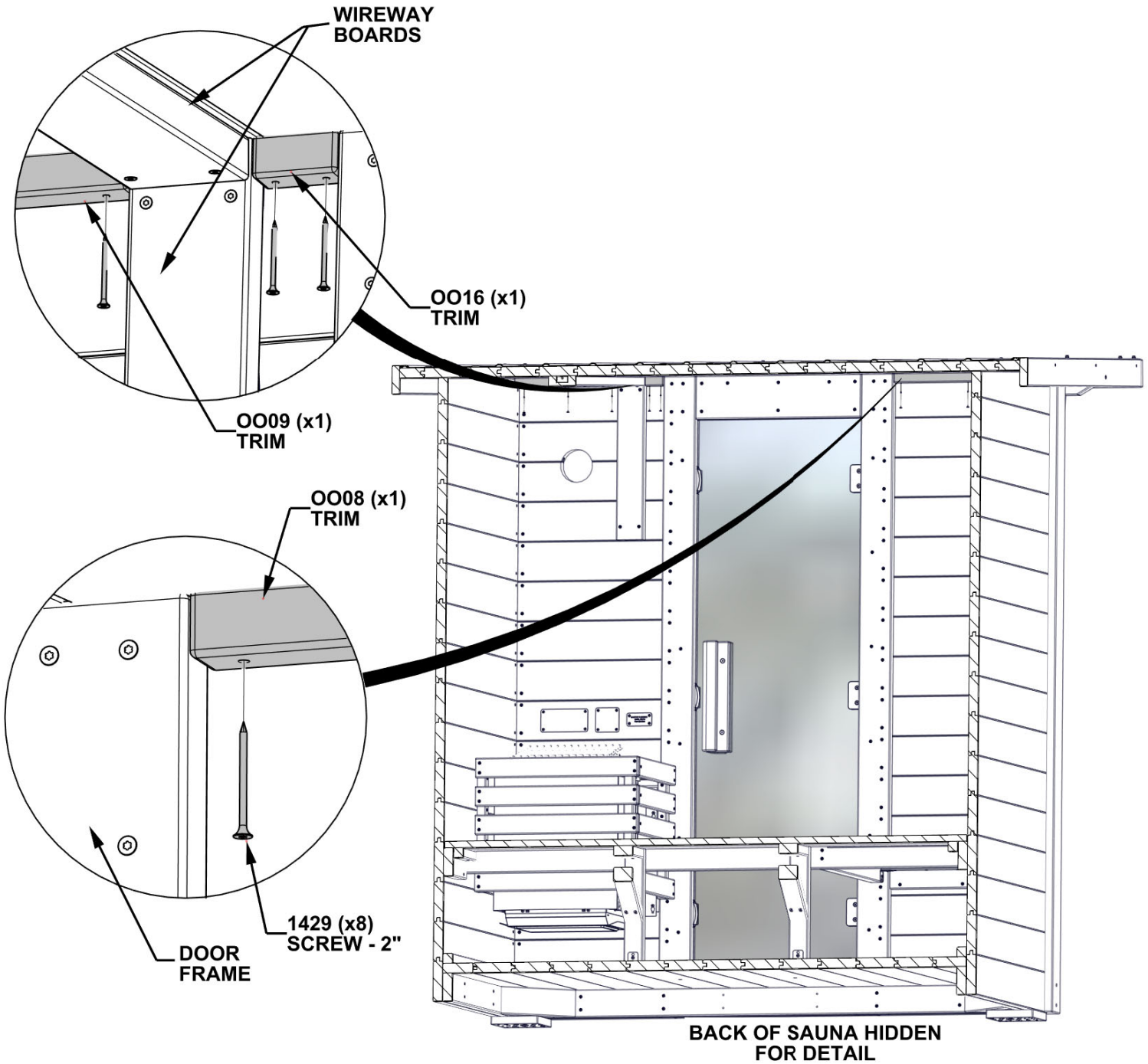

STEP 80 - TRIM ASSEMBLY

QTY	PART NUMBER	DESCRIPTION
4	H101429	SCREW TFH 8X2 SS-BLK

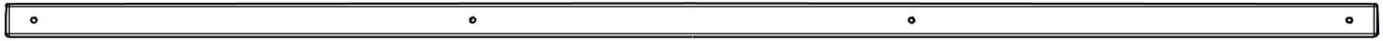

OO15 TRIM - W4L22730
(x1) 1 3/16"x1 3/16"x48 1/4" (30x30x1226)

- POSITION TRIM AGAINST WALL AND PREVIOUSLY INSTALLED TRIM AND ATTACH AS SHOWN.

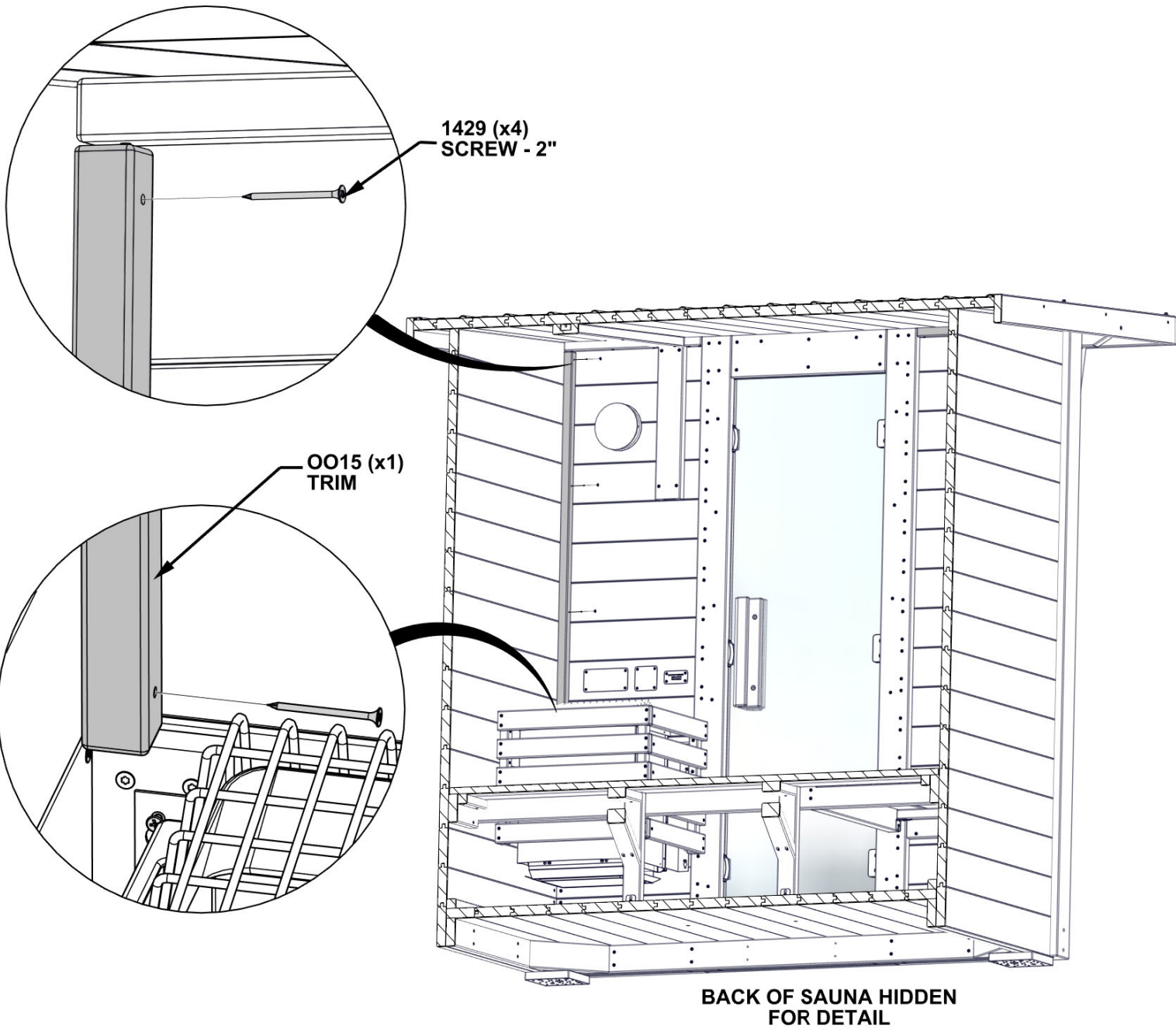

STEP 81 - TRIM ASSEMBLY

QTY	PART NUMBER	DESCRIPTION
4	H101429	SCREW TFH 8X2 SS-BLK

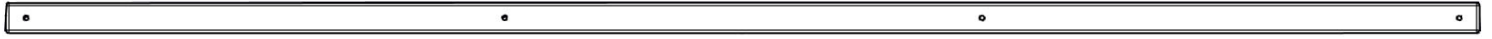

OO17 TRIM - W4L22732
(x1) 1 3/16"x1 3/16"x57 1/16" (30x30x1449)

- POSITION TRIM AGAINST WALL AND PREVIOUSLY INSTALLED TRIM AND ATTACH AS SHOWN.

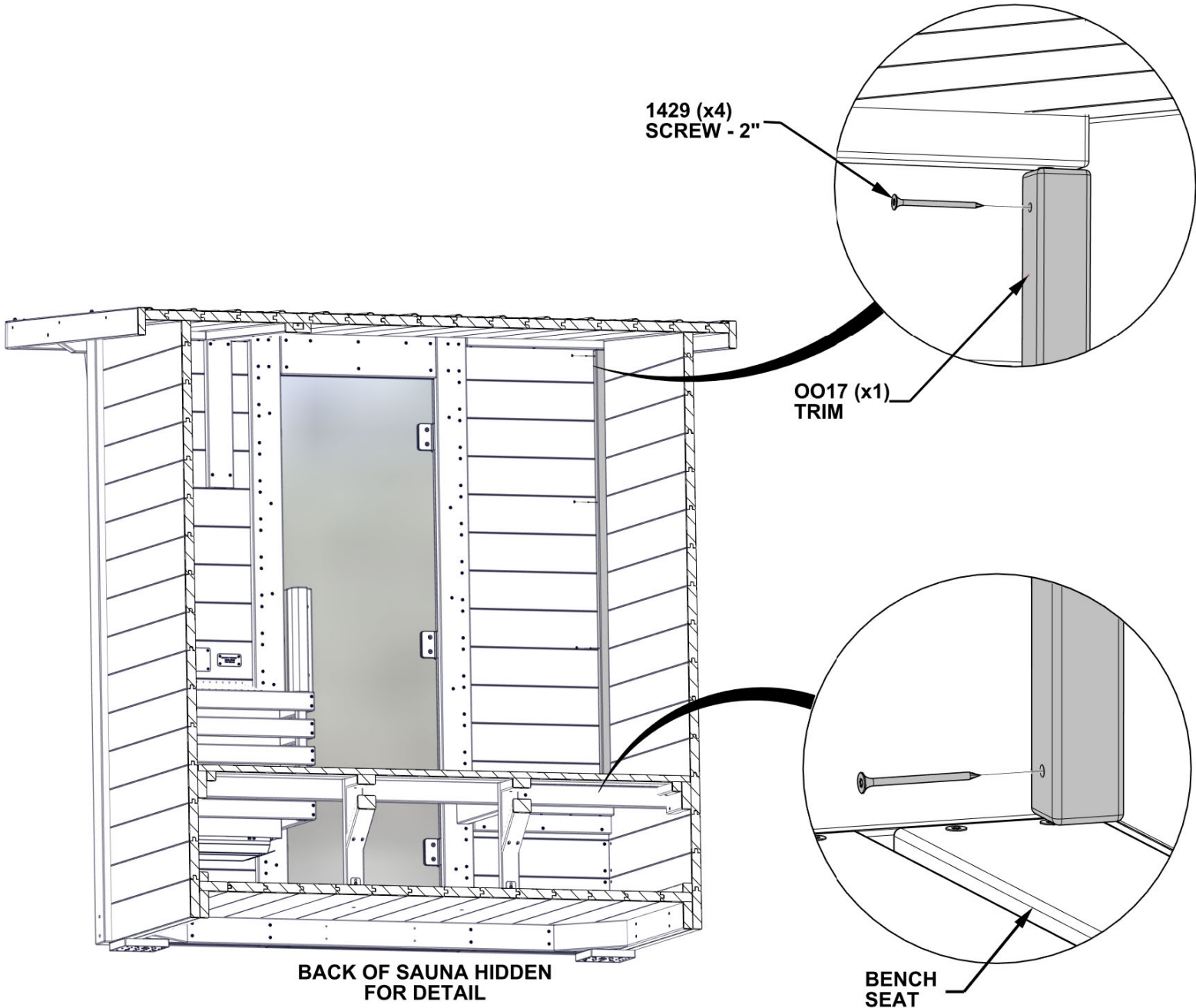

STEP 82 - TRIM ASSEMBLY

QTY	PART NUMBER	DESCRIPTION
6	H101429	SCREW TFH 8X2 SS-BLK



OO13 TRIM - W4L22414
(x1) 1 3/16"x1 3/16"x61" (30x30x1549)

- POSITION TRIM AGAINST SIDE WALL AND PREVIOUSLY INSTALLED TRIM AND ATTACH AS SHOWN.

**NOTE THE DIRECTION OF THE ANGLE CUT
ON THE ENDS FOR PROPER FIT**

OO13 (x1)
TRIM

1429 (x6)
SCREW - 2"

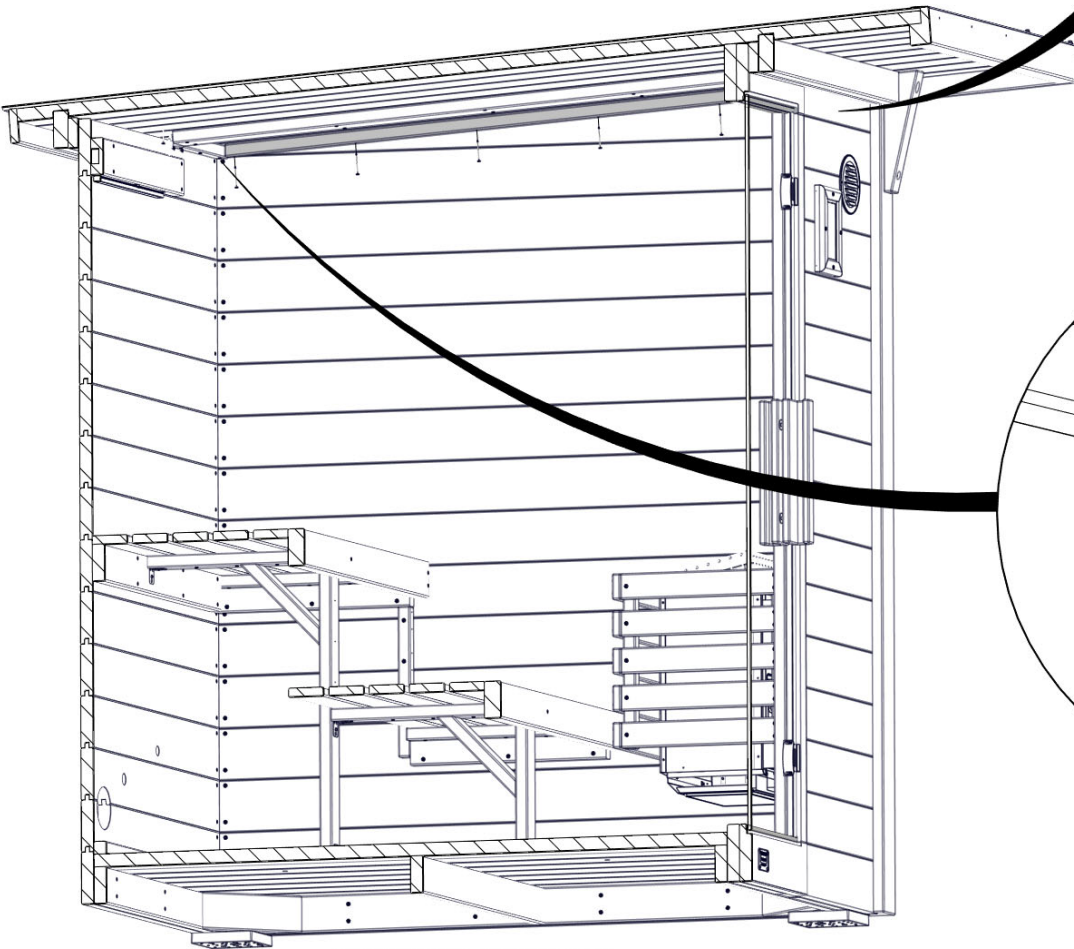
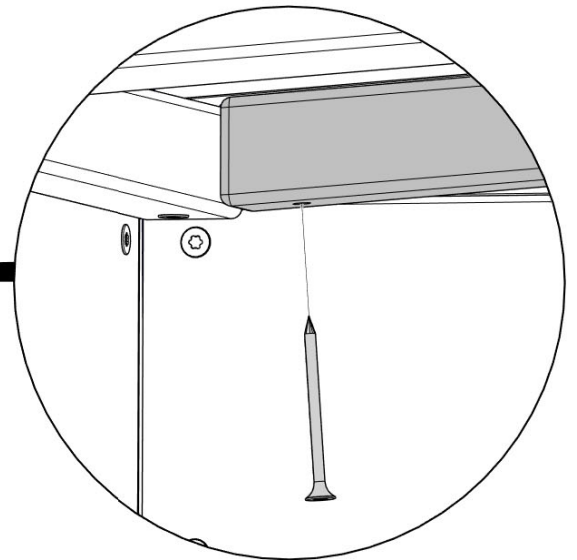
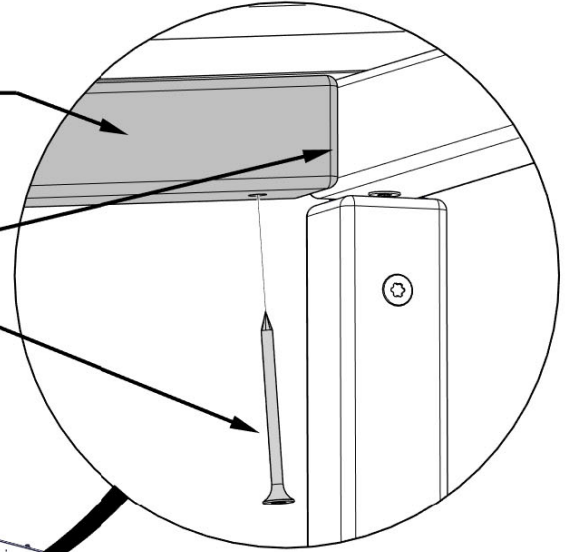

**LEFT SIDE OF SAUNA
HIDDEN FOR DETAIL**

STEP 83 - TRIM ASSEMBLY

QTY	PART NUMBER	DESCRIPTION
6	H101429	SCREW TFH 8X2 SS-BLK



OO13 TRIM - W4L22414
(x1) 1 3/16"x1 3/16"x61" (30x30x1549)

- POSITION TRIM AGAINST SIDE WALL AND PREVIOUSLY INSTALLED TRIM AND ATTACH AS SHOWN.

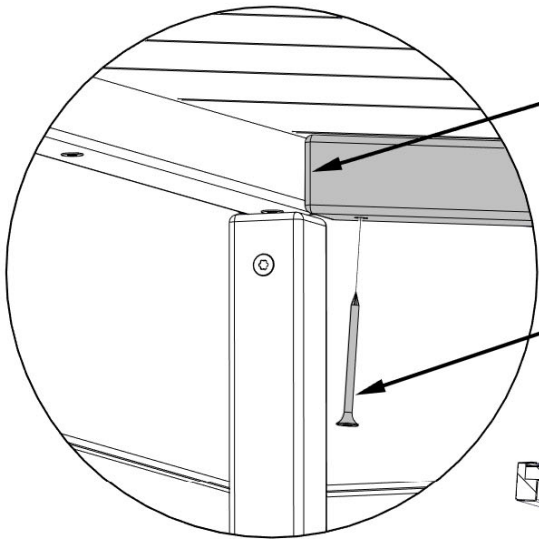

NOTE THE DIRECTION OF THE ANGLE CUT ON THE ENDS FOR PROPER FIT

1429 (x6)
SCREW - 2"

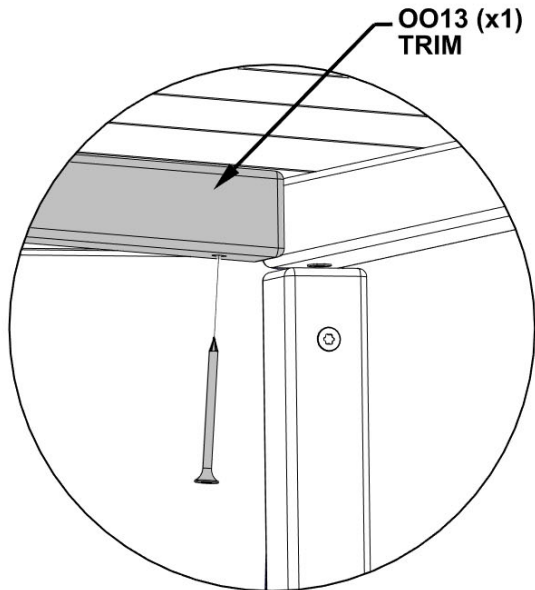

OO13 (x1)
TRIM

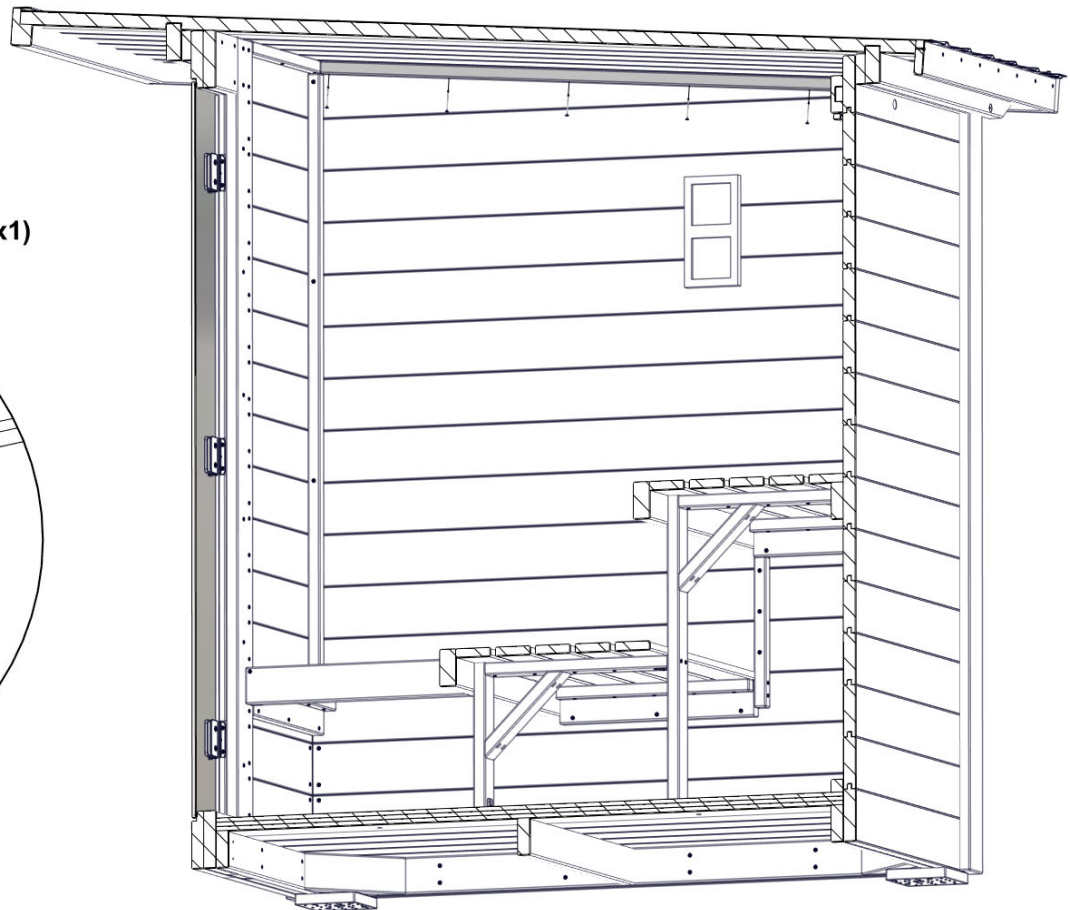

**RIGHT SIDE OF SAUNA
HIDDEN FOR DETAIL**

STEP 84 - TRIM ASSEMBLY

QTY	PART NUMBER	DESCRIPTION
3	H101429	SCREW TFH 8X2 SS-BLK

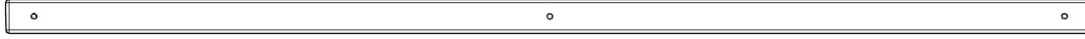

OO14 TRIM - W4L22607
(x1) 1 3/16"x1 3/16"x37 7/8" (30x30x962)

- POSITION TRIM AGAINST SIDE WALL AND PREVIOUSLY INSTALLED TRIM AND ATTACH AS SHOWN.

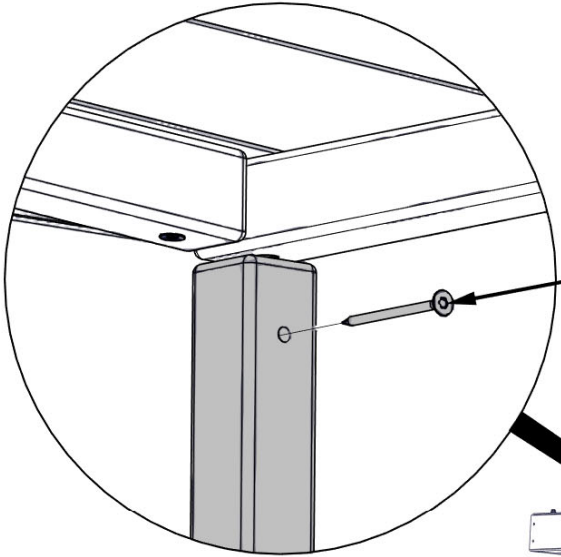

1429 (x6)
SCREW - 2"

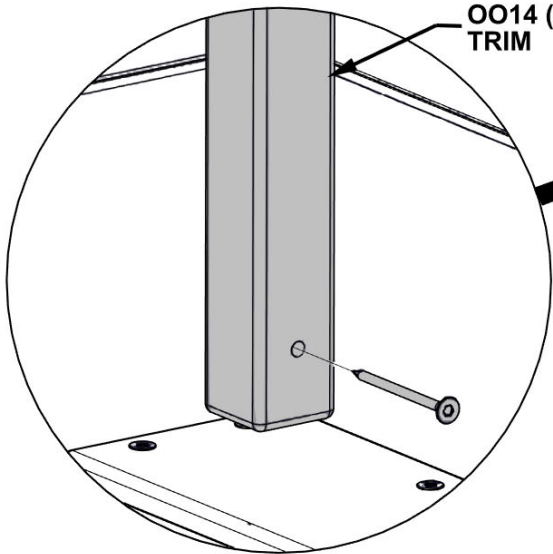

OO14 (x1)
TRIM

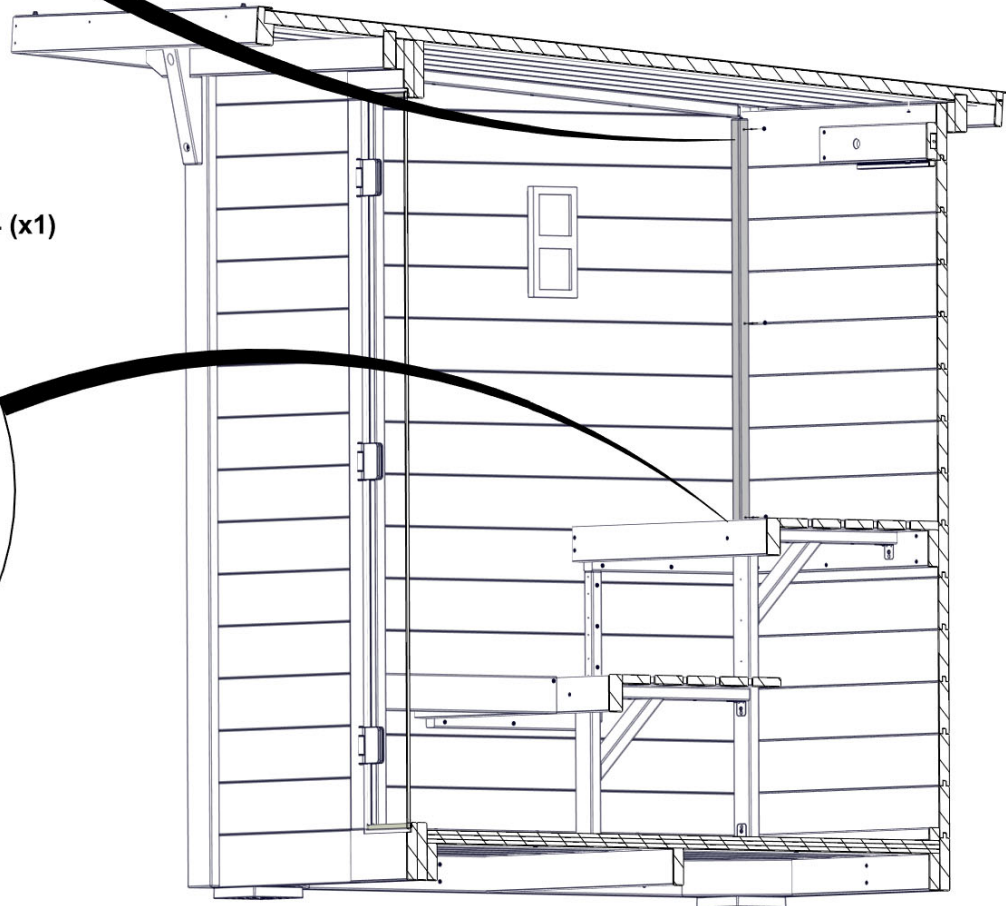

RIGHT SIDE OF SAUNA
HIDDEN FOR DETAIL

STEP 85 - TRIM ASSEMBLY

QTY	PART NUMBER	DESCRIPTION
3	H101429	SCREW TFH 8X2 SS-BLK

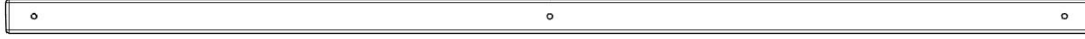

OO14 TRIM - W4L22607
(x1) 1 3/16"x1 3/16"x37 7/8" (30x30x962)

- POSITION TRIM AGAINST SIDE WALL AND PREVIOUSLY INSTALLED TRIM AND ATTACH AS SHOWN.

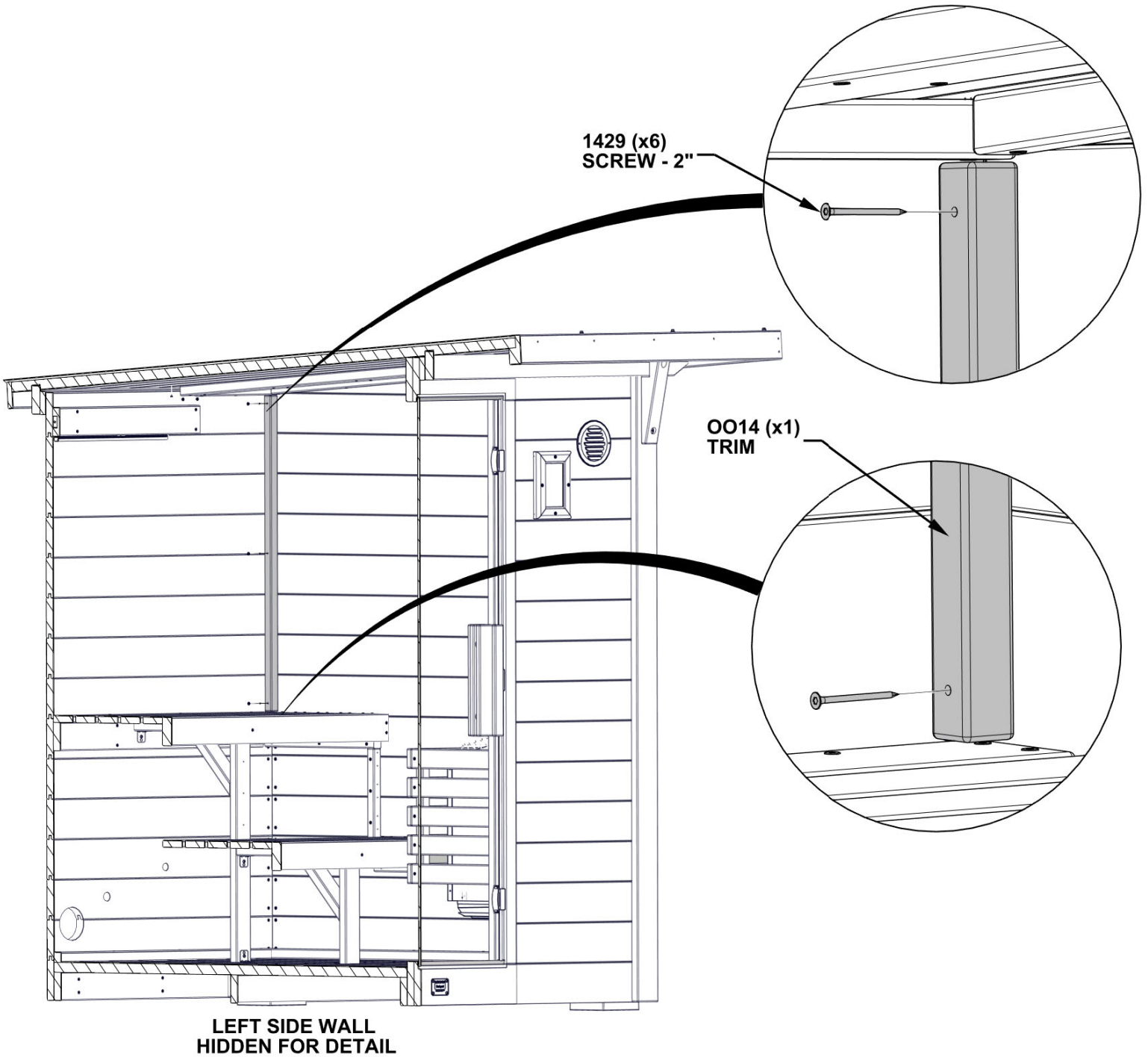

STEP 86 - ANCHORS

QTY	PART NUMBER	DESCRIPTION
8	H100205	BOLT WH 5/16x2 1/4 BLK

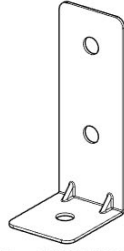

A4M05917 ANCHOR BRACKET
(x4)

- ALIGN HOLES IN ANCHOR BRACKETS WITH HOLES IN POST AND ATTACH AS SHOWN.

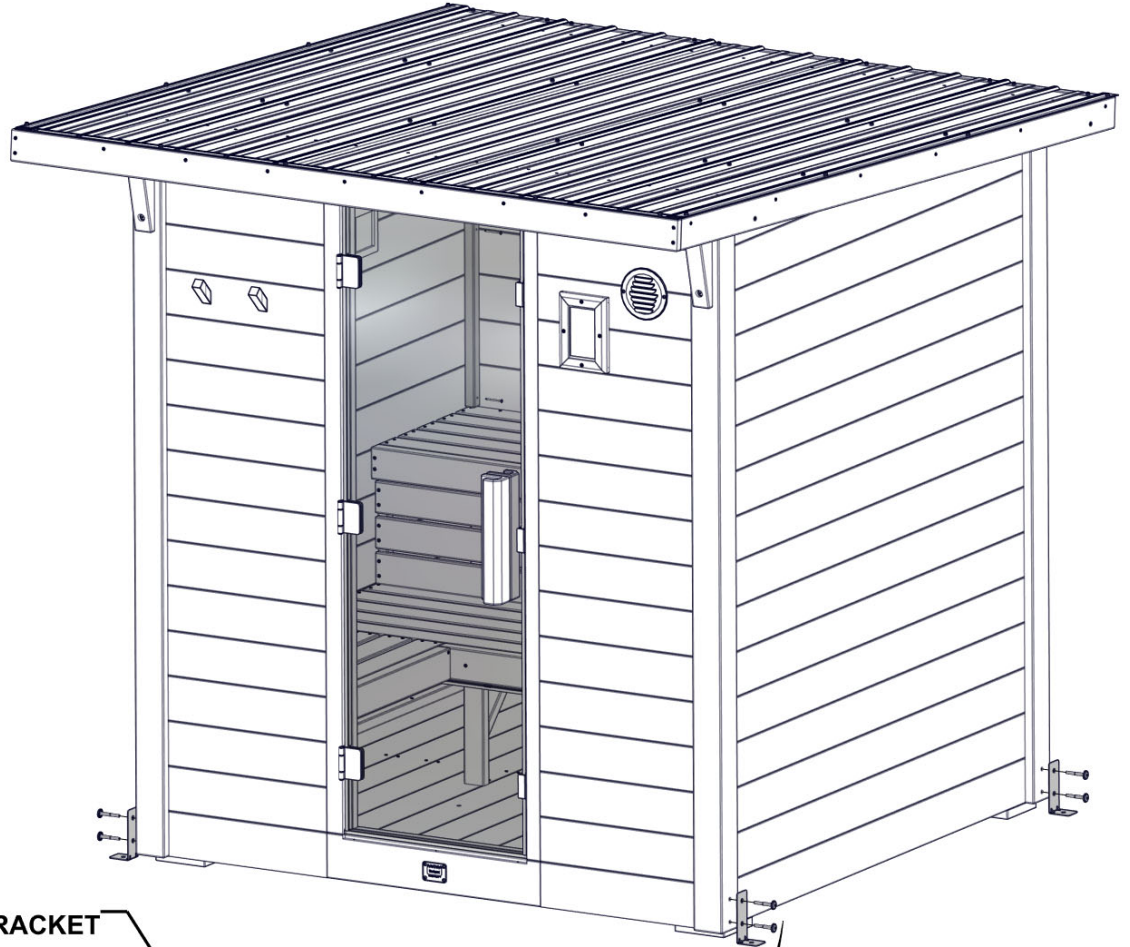

5917 (x4)
ANCHOR BRACKET

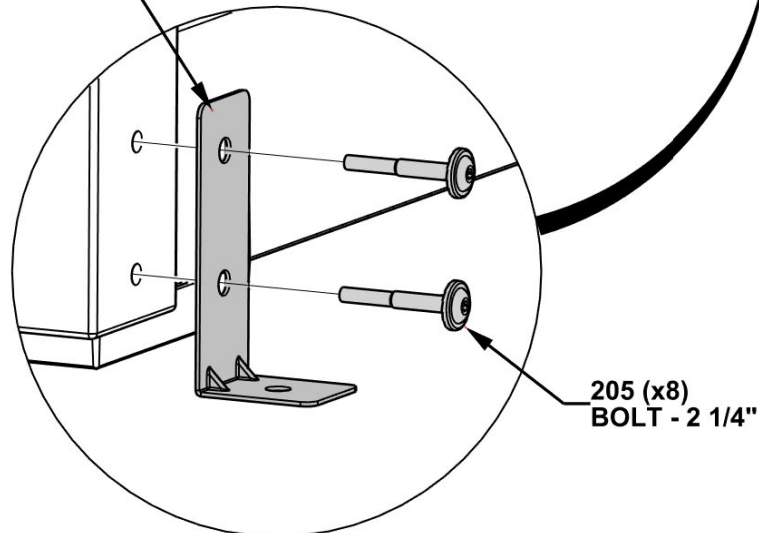

STEP 87 - ANCHOR TO GROUND

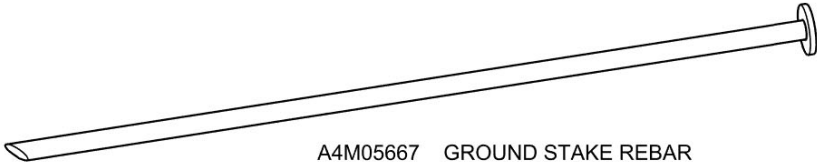

A4M05667 GROUND STAKE REBAR
(x4)

- IF SAUNA IS TO SIT ON A CONCRETE SURFACE, SEE STEP 88.

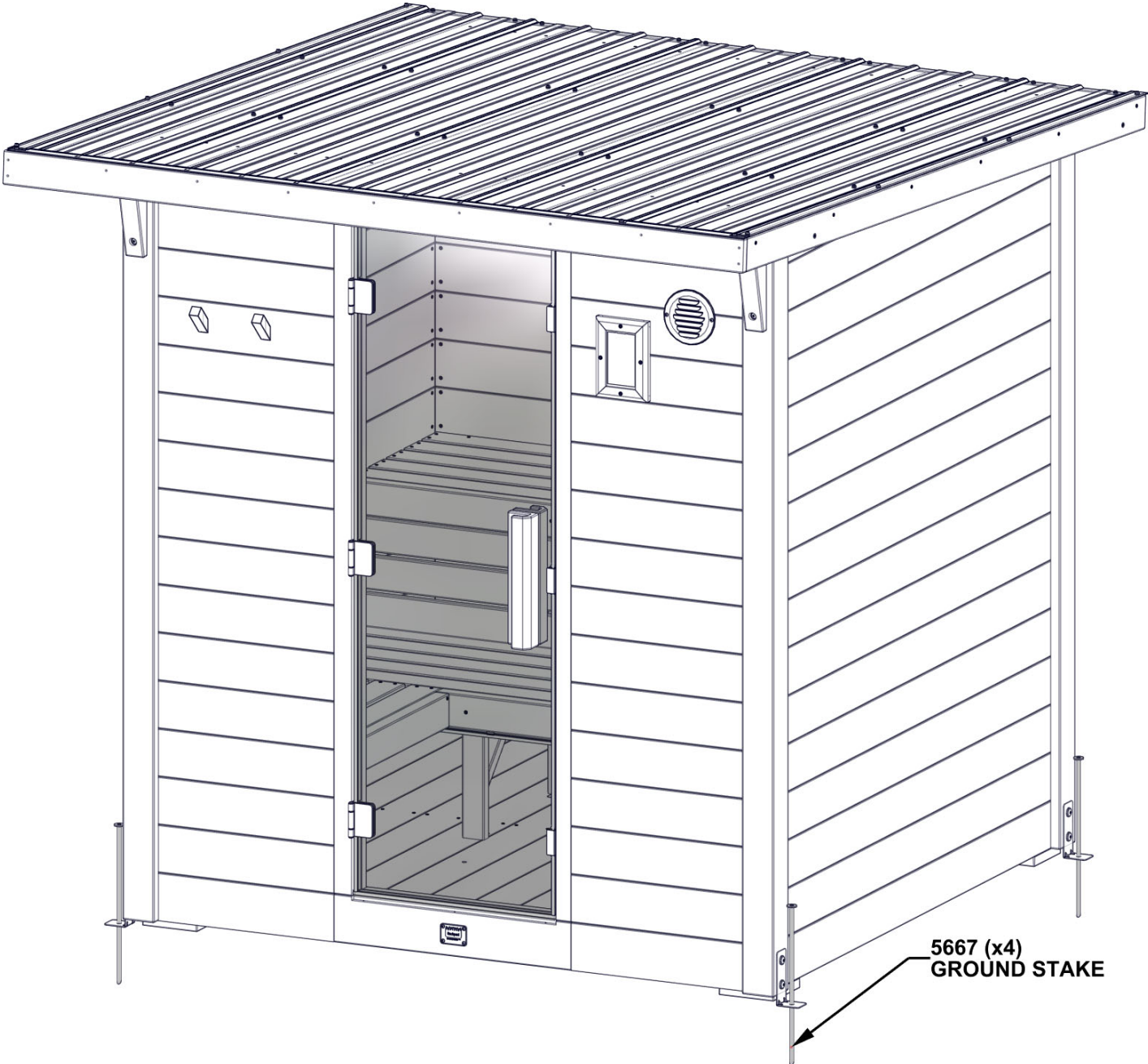

5667 (x4)
GROUND STAKE

STEP 88 - ANCHOR TO CONCRETE

QTY	PART NUMBER	DESCRIPTION
4	H101165	CONCRETE ANCHOR 3/8x3" BLK

- IF SAUNA IS TO SIT ON THE GROUND, SEE STEP 87.

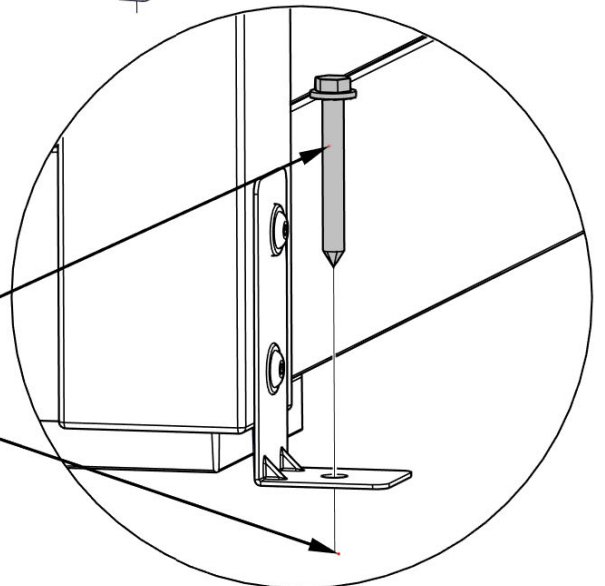
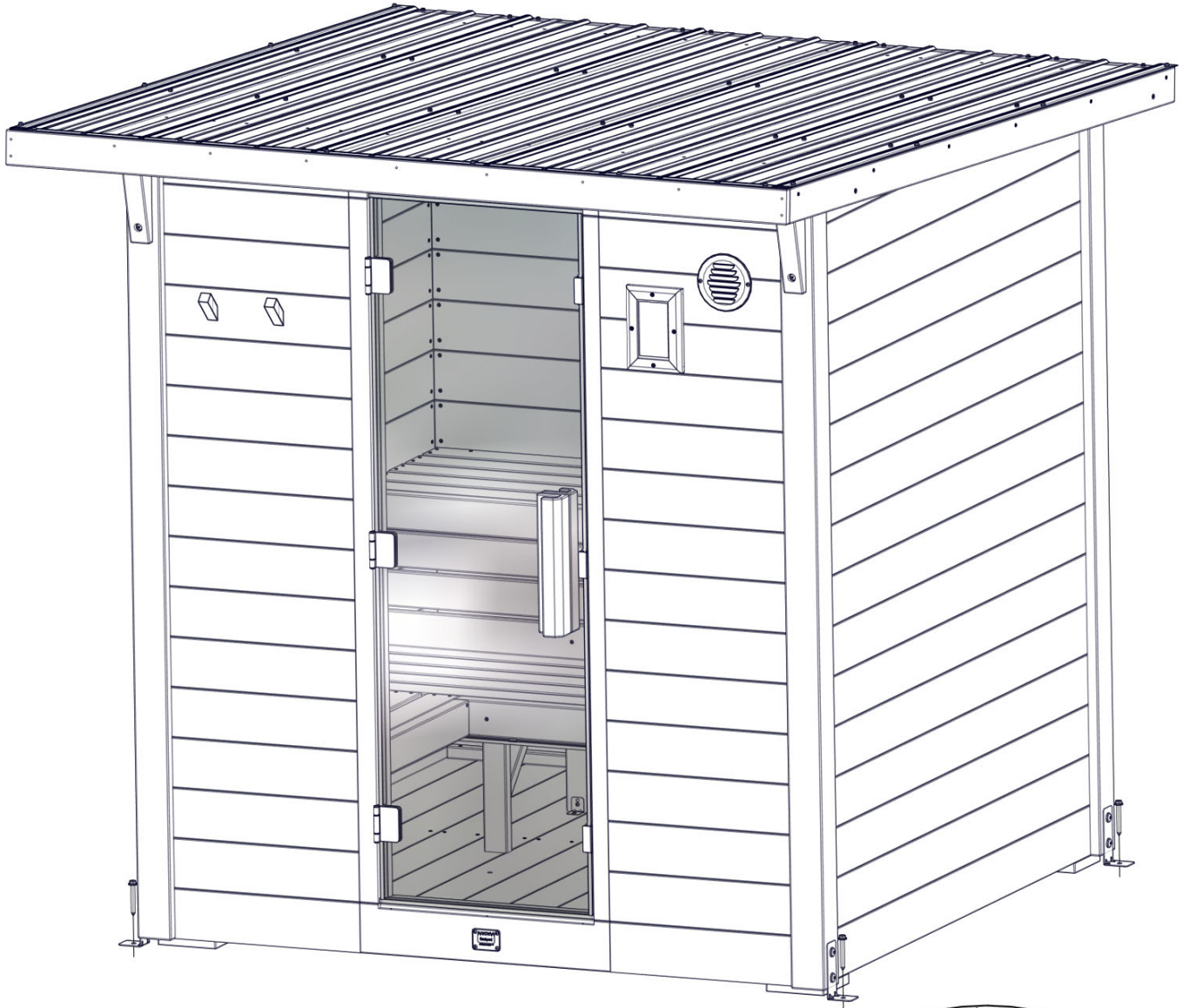

1165 (x4)
CONCRETE ANCHOR-3"

PRE-DRILL HOLES FOR
CONCRETE ANCHORS USING A
5/16" [8mm] CONCRETE DRILL BIT.

STEP 89 - FINISH

- ONCE THE ASSEMBLY IS COMPLETE, SWEEP AND VACUUM THE INSIDE OF THE SAUNA. WIPE DOWN THE ENTIRE SAUNA WITH A DAMP CLOTH TO REMOVE ANY REMAINING DIRT, DUST, AND DEBRIS.
- THE OUTSIDE ONLY NEEDS TO BE SEALED. STAINING IS OPTIONAL BASED ON DESIRED LOOK.

- DO NOT USE CHEMICAL-BASED CLEANING AGENTS INSIDE THE SAUNA.

