



MANUFACTURED BY:
Backyard Discovery
3305 Airport Drive, Pittsburg, KS 66762
800-856-4445

Basepoint Business Centre: Rivermead Drive, Westlea, Swindon SN5 7EX Phone: 0800-118-2476
J.P. Coenstraat 7, The Bridge, The Hague, 2595 WP, Netherlands Phone: 0800-567-8990

ENDEAVOR II

Swing Set

Model # 2200135



WARNING

Adult Assembly Required.

Not suitable for children under 36 months due to small parts.

FOR DOMESTIC USE ONLY. INTENDED FOR OUTDOOR USE.



Please visit www.backyarddiscovery.com

For the most up to date assembly manual, to register your set, or to order replacement parts

Para obtener instrucciones en español, visite www.backyarddiscovery.com



EASY STEP-BY-STEP
3D INTERACTIVE INSTRUCTIONS

DOWNLOAD THE FREE APP



INSTALLATION
SERVICES
AVAILABLE!
See inside for details

Made in China
INS-2200135-A-ENDEAVOR II-ENG 03/07/22

Owner's Manual - Basic Setup Dimensions & Assembly Notes

Place the set on level ground, not less than 6'-7" [2 m] from any structure or obstruction such as a fence, garage, house, overhanging branches, laundry lines, or electrical wires.

- While assembling unit, take time before and after each phase to make sure fort is level. If fort is not level, assembly will be difficult and improper assembly may result. Extra care must be taken to insure the fort is square.
- The safe play area refers to a zone extending 6'-7" (2 m) beyond the play product on all sides, including the space above the play product.

SAFE PLAY AREA DIAGRAM

Ground Dimensions

22'-5 3/4" [6.8 m] x 10'-1 1/4" [3.1 m] x 9'-10 3/4" [3 m]

Safe Play Area

35'-7 1/2" [10.9 m] x 23'-3 1/4" [7.1 m] x 16'-5 3/4" [5 m]

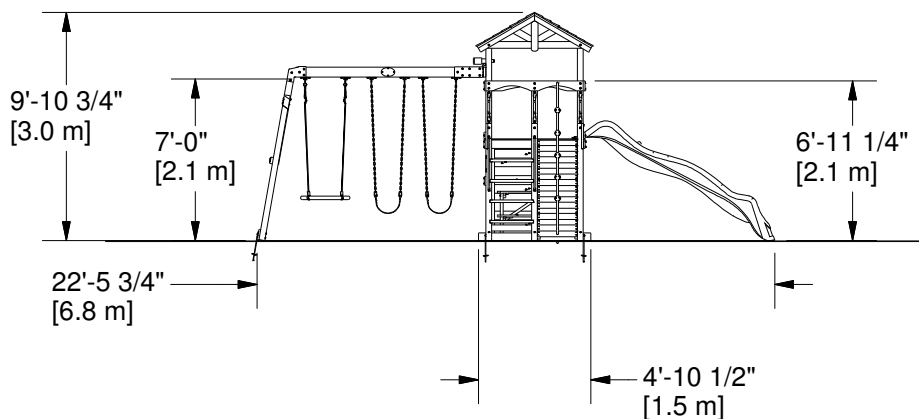
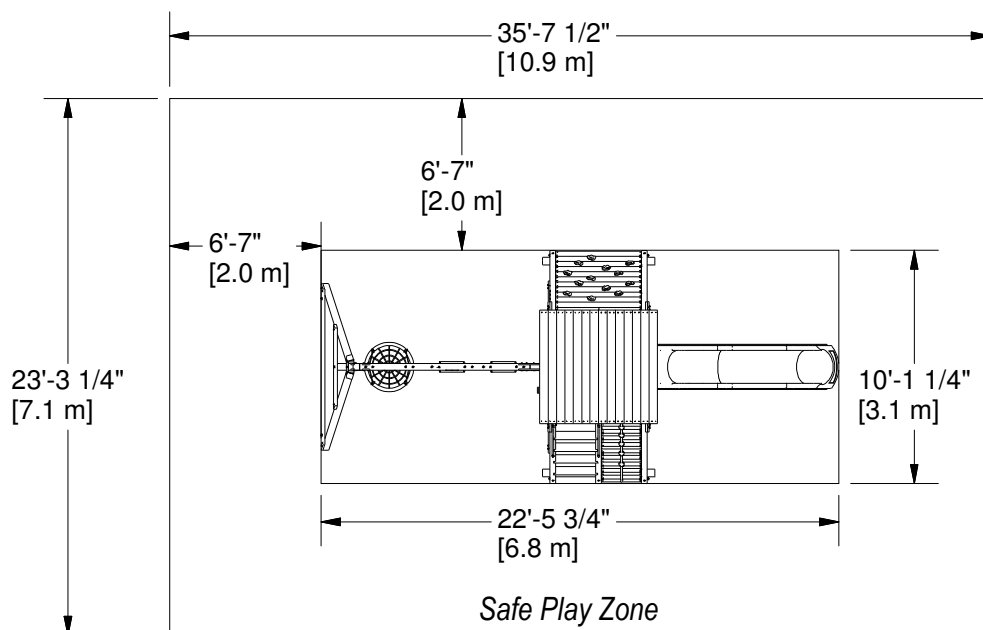

SAFE PLAY HEIGHT: 16'-5 3/4" [5 m]
MAXIMUM FALL HEIGHT: 7' [2.1 m]

General Information:

Your set has been designed and engineered for children only and for residential use only.
A maximum of 150 lbs. per child is recommended for play activities designed for individual use.
A maximum of 120 lbs. per child is recommended for play activities designed for multiple child use.
A maximum of 9 children is recommended for this swing set.

Owner's Manual - Parts Identification

Wood Components (Not to Scale)



A50 | SWING BEAM 2 POSITION - W4L16461
(x1) | 3 3/8"x5 1/4"x89 1/2" (86x134x2274)



A2 | SB 9" BLOCK - W4L16459
(x1) | 3 3/8"x5 1/4"x9" (86x134x228)



AL01 | STEP - W4L16431
(x4) | 1 3/8"x4 3/8"x22 3/4" (36x112x579)

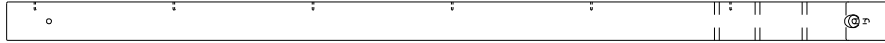

B02 | LEG - W4L16417
(x1) | 3"x3"x69 1/4" (76x76x1760)

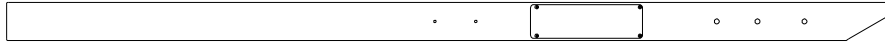

B03 | LEG - W2A03278
(x1) | 3"x3"x69 1/4" (76x76x1760)



B04 | UPRIGHT - W4L16419
(x1) | 3"x3"x35" (76x76x888)

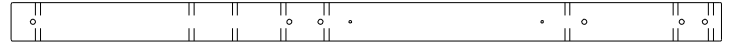

B06 | UPRIGHT - W4L16425
(x2) | 3"x3"x55 1/2" (76x76x1410)



B07 | GROUND BOARD - W4L16427
(x1) | 3"x3"x58 5/8" (76x76x1488)



B08 | LEG - W4L16433
(x1) | 3"x3"x69 1/4" (76x76x1760)

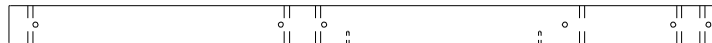

B10 | UPRIGHT - W4L16435
(x2) | 3"x3"x55 1/2" (76x76x1410)

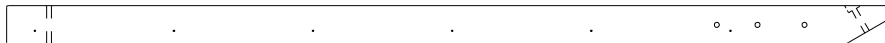

B11 | LEG - W4L16441
(x1) | 3"x3"x69 1/4" (76x76x1760)



B12 | GROUND BOARD - W4L16446
(x1) | 3"x3"x58 5/8" (76x76x1488)

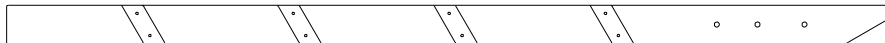

B13 | LEG - W4L16476
(x1) | 3"x3"x69 1/4" (76x76x1760)



B50 | ANGLE BRACE - W4L16463
(x2) | 3"x3"x87 1/8" (76x76x2212)

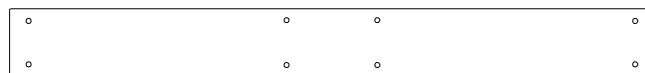

D01 | WALL RAIL - W4L16426
(x1) | 1 3/8"x5 1/4"x50 3/8" (36x134x1280)



D02 | WALL RAIL - W4L16422
(x1) | 1 3/8"x5 1/4"x50 3/4" (36x134x1288)

Owner's Manual - Parts Identification

Wood Components (Not to Scale)



E01 | FLOOR JOIST - W4L16420
(x1) | 1 3/8"x3 3/8"x50 3/8" (36x86x1280)



E05 | BLOCK - W4L16474
(x1) | 1 3/8"x3 3/8"x4 3/4" (36x86x120)

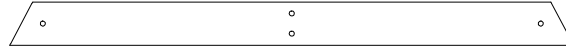

E50 | END SUPPORT - W4L16464
(x1) | 1 3/8"x3 3/8"x44 1/8" (36x86x1120)



F01 | CLEAT - W4L16440
(x4) | 1 3/8"x2"x59 1/2" (36x52x1510)



F05 | UPPER SUPPORT - W4L16470
(x2) | 1 3/8"x2 3/8"x16 3/4" (36x60x424)



F06 | LEG - W4L16471
(x4) | 1 3/8"x2 3/8"x29 7/8" (36x60x757)



F08 | LEG SUPPORT - W4L16472
(x2) | 1 3/8"x2 3/8"x39 5/8" (36x60x1006)



F12 | ANGLE BRACE - W4L16473
(x2) | 1 3/8"x2 3/8"x20" (36x60x507)



G01 | ROCK WALL BOARD - W4L16452
(x2) | 1"x5 1/4"x44 5/8" (24x134x1135)



G02 | WALL RAIL - W4L16423
(x1) | 1"x5 1/4"x50 3/8" (24x134x1280)



G03 | WALL RAIL - W4L16424
(x1) | 1"x5 1/4"x50 3/4" (24x134x1288)



G04 | WALL RAIL - W4L16443
(x1) | 1"x5 1/4"x50 3/8" (24x134x1280)



G05 | ROCK WALL BOARD - W4L16444
(x5) | 1"x5 1/4"x44 5/8" (24x134x1135)



G06 | ROCK WALL BOARD - W4L16445
(x4) | 1"x5 1/4"x44 5/8" (24x134x1135)



G50 | GROUND BOARD - W4L16465
(x1) | 1"x5 1/4"x86 3/4" (24x134x2202)

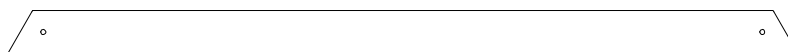

H01 | FLOOR RAIL - W4L16428
(x1) | 1"x3 3/8"x61 3/4" (24x86x1569)



H02 | FLOOR RAIL - W4L16429
(x2) | 1"x3 3/8"x18 3/4" (24x86x477)



H03 | FLOOR RAIL - W4L16430
(x5) | 1"x3"x3 3/8" (24x76x86)

Owner's Manual - Parts Identification

Wood Components (Not to Scale)



H04 | ROPE WALL BOARD - W4L16438
(x8) | 1"x3 3/8"x20 7/8" (24x86x529)



H05 | WALL RAIL - W4L16450
(x2) | 1"x3 3/8"x29 7/8" (24x86x760)

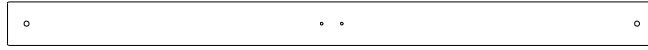

H07 | WALL RAIL - W4L16453
(x2) | 1"x3 3/8"x50 3/4" (24x86x1288)



H08 | WALL RAIL - W4L16454
(x2) | 1"x3 3/8"x52 1/4" (24x86x1328)



H09 | ROOF RAIL - W4L16455
(x4) | 1"x3 3/8"x34 1/2" (24x86x877)



H10 | GABLE BOARD - W4L16456
(x2) | 1"x3 3/8"x15 3/4" (24x86x400)



H11 | GABLE CLEAT - W4L16457
(x2) | 1"x3"x3 3/8" (24x76x86)



H12 | GABLE BOARD - W4L16458
(x4) | 1"x3 3/8"x14 5/8" (24x86x370)



H80 | SLIDE BRACE WIDE - W4L15715
(x1) | 1"x3 3/8"x18 3/8" (24x86x466)



H83 | SLIDE BRACE - W4L13333
(x2) | 1"x3 3/8"x20 1/8" (24x86x512)

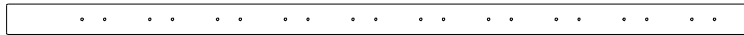

J01 | ROCK WALL CLEAT - W4L16447
(x1) | 1"x2 3/8"x58 1/2" (24x60x1486)



K04 | FLOOR BOARD - W4L16448
(x1) | 5/8"x4 3/4"x44 5/8" (16x120x1135)



K05 | FLOOR BOARD - W4L16449
(x1) | 5/8"x4 3/4"x20 7/8" (16x120x529)

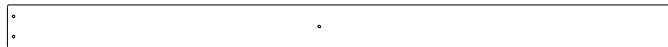

M01 | FLOOR BOARD - W4L16437
(x13) | 5/8"x3 3/8"x52 3/4" (16x86x1339)



M02 | ROPE WALL BOARD - W4L16436
(x8) | 5/8"x3 3/8"x20 7/8" (16x86x529)

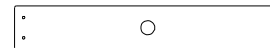

M03 | ROPE WALL BOARD - W4L16451
(x1) | 5/8"x3 3/8"x20 7/8" (16x86x529)



M04 | PICKET - W4L16466
(x9) | 5/8"x3 3/8"x29 7/8" (16x86x760)



M05 | SAFETY BOARD - W4L16467
(x1) | 5/8"x3 3/8"x26 7/8" (16x86x682)

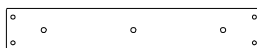

M70 | SLIDE BED SUPPORT - W100935
(x1) | 5/8"x3 3/8"x19 7/8" (16x86x505)

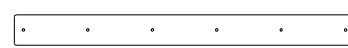

N01 | ROOF CLEAT - W4L16460
(x4) | 5/8"x2 3/8"x26 5/8" (16x60x675)

Owner's Manual - Parts Identification

Wood Components (Not to Scale)



O70 | SLIDE MOUNTING BOARD - W4L09040
(x1) | 5/8"x1 3/8"x20 3/8" (16x34x517)



Q01 | FLOOR RAIL - W4L16173
(x2) | 1"x4 3/8"x67 5/8" (24x112x1718)

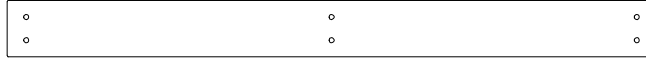

Q02 | FLOOR RAIL - W4L16418
(x1) | 1"x4 3/8"x50 3/4" (24x112x1288)



Q03 | FLOOR RAIL - W4L16421
(x1) | 1"x4 3/8"x50 3/4" (24x112x1288)



Q04 | SAFETY RAIL - W4L16475
(x1) | 1"x4 3/8"x89 1/2" (24x112x2274)



SP01 | SWING BEAM SUPPORT - W4L16462
(x1) | 3 3/8"x3 3/8"x50" (86x86x1269)

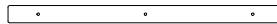

T01 | CLEAT - W4L16442
(x3) | 1"x1 3/8"x21 1/2" (24x34x546)



Y01 | FLOOR BOARD - W4L16432
(x2) | 5/8"x4"x20 7/8" (16x102x529)



Y02 | FLOOR BOARD - W4L16439
(x1) | 5/8"x4"x44 5/8" (16x102x1135)

Owner's Manual - Parts Identification

Wood Components (Not to Scale)



RP1 | ROOF PANEL - W2A03410
(x2) | 1 5/8"x15"x59 1/8" (42x382x1503)



RP2 | ROOF PANEL - W2A03411
(x2) | 1 5/8"x20 5/8"x66" (42x524x1503)



TP1 | PICNIC TABLE TOP - W2A03413
(x1) | 1 7/8"x16 15/16"x40 11/16" (48x430x1034)

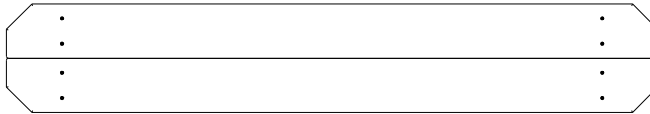

TP2 | PICNIC TABLE SEAT - W2A03414
(x2) | 1 9/16"x6 3/4"x40 11/16" (40x172x1034)

Owner's Manual - Parts Identification

Hardware Components

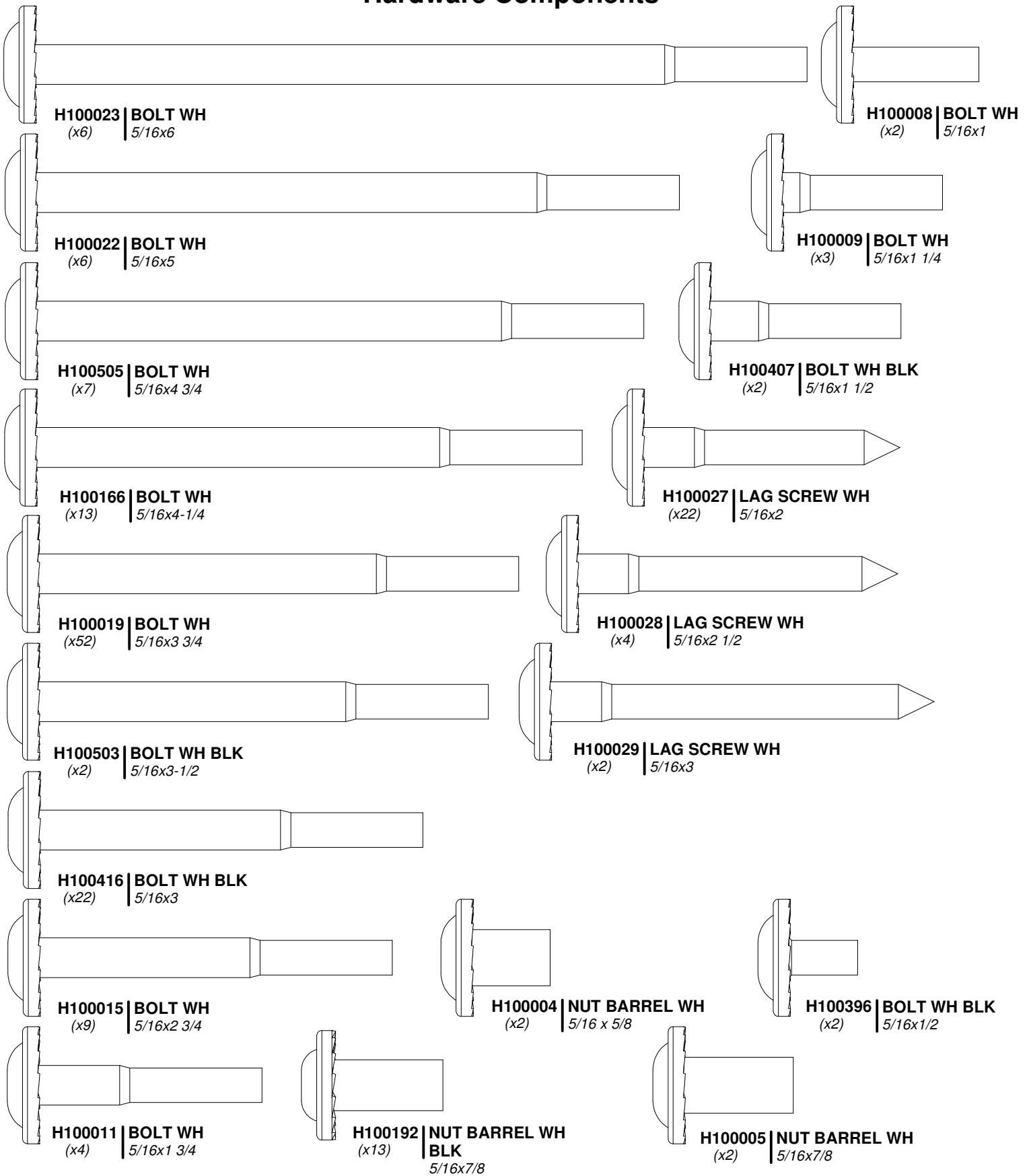

Owner's Manual - Parts Identification

Hardware Components

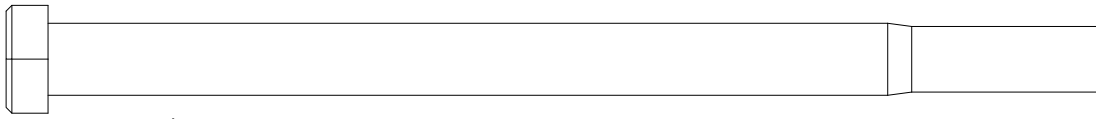

H100654 | BOLT HEX
(x13) | 3/8x5-1/2

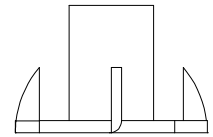

H100073 | T-NUT
(x13) | 3/8

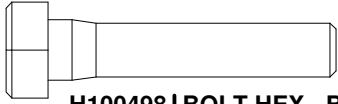

H100498 | BOLT HEX - BLK
(x4) | 5/16x1 1/2

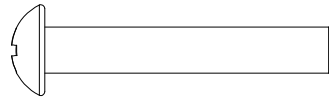

H101098 | BOLT PPH BLK
(x15) | 1/4x1-1/2

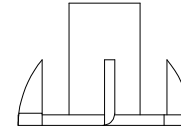

H100074 | T-NUT
(x103) | 5/16

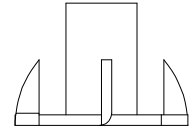

H100379 | T-NUT BLK
(x9) | 5/16



H100092 | SCREW PFH
(x46) | 8x3

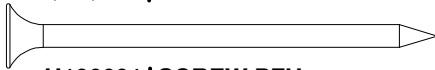

H100091 | SCREW PFH
(x41) | 8X2 1/4

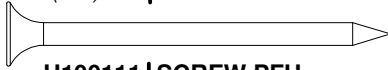

H100111 | SCREW PFH
(x80) | 8x2

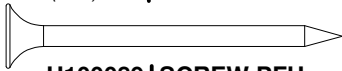

H100089 | SCREW PFH
(x77) | 8x1 3/4

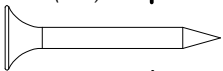

H100088 | SCREW PFH
(x4) | 8x1 1/8

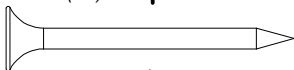

H100086 | SCREW PFH
(x191) | 8x1 1/2

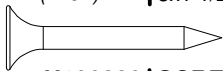

H100380 | SCREW PFH BLK
(x26) | 8x1 1/8

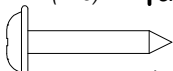

H100070 | SCREW PWH
(x4) | 8x3/4

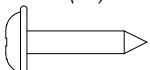

H100128 | SCREW PWH
(x2) | 8x5/8

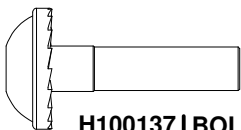

H100137 | BOLT WH
(x28) | 1/4x1

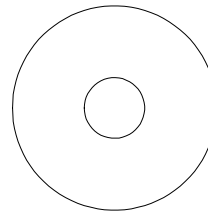

H100478 | WASHER FLAT
(x4) | BLK
8x27

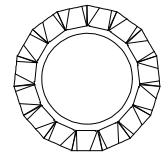

H100031 | WASHER LOCK
(x4) | EXT
12x19

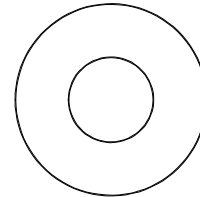

H100102 | WASHER FLAT
(x13) | 11x25

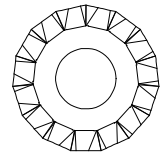

H100030 | WASHER LOCK
(x102) | EXT
8x19

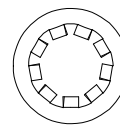

H100108 | WASHER LOCK
(x28) | INT
8x15

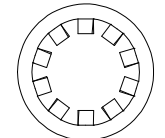

H100107 | WASHER LOCK
(x13) | INT
10x18

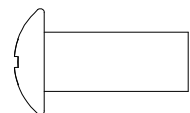

H100831 | NUT BARREL PTH
(x4) | BLK
1/4x3/4

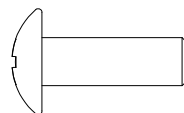

H100832 | BOLT PTH BLK
(x4) | (with LOCTITE)
1/4x3/4

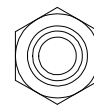

H100653 | NUT LOCK BLK
(x15) | 1/4

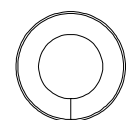

H100477 | WASHER SPLIT
(x4) | BLK
5/16

Owner's Manual - Parts Identification

Accessory Components (Not to Scale)



A100164 | **BYD ID TAG**
(x1) | **(LARGE) AGES**
3-10

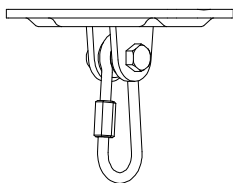

A4M00505 | **SWING HANGER**
(x6)



A4M01047 | **L BRACKET**
(x2) | **2.5x38x55x55**

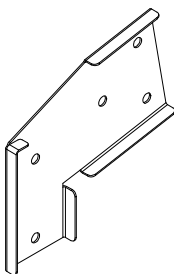

A4M00617 | **SWING BEAM**
(x1) | **EXTENSION**
BRACKET-LEFT

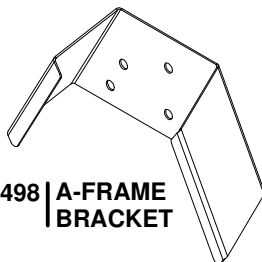

A4M01498 | **A-FRAME**
(x1) | **BRACKET**

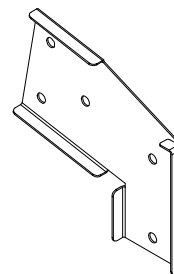

A4M00618 | **SWING BEAM**
(x1) | **EXTENSION**
BRACKET-RIGHT

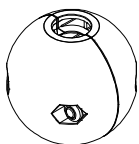

A6P00508 | **ROPE CLAMP KIT**
(x7)

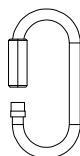

A100069 | **QUICK LINK**
(x4)

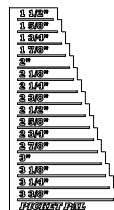

A6P00410 | **PICKET PAL**
(x1)



A100047 | **CHAIN GREEN**
(x4) | **57"**

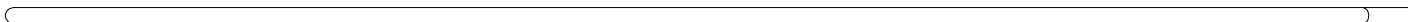

A6P00520 | **ROPE**
(x1)



A100027 | **SWING SEAT**
(x2) | **GREEN 26"**

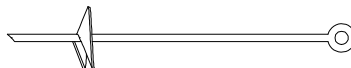

A100178 | **AUGER GROUND**
(x6) | **STAKE**

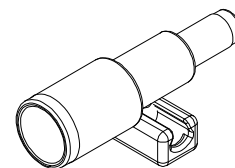

A6P00096 | **TELESCOPE**
(x1)

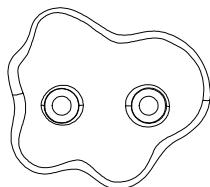

A6P00036 | **GREEN HC ROCK**
(x7) | **#1**

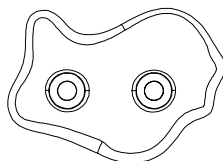

A6P00037 | **GREEN HC ROCK**
(x6) | **#2**

Owner's Manual - Parts Identification

Accessory Components (Not to Scale)



A4M01126 | 26" WEB SWING SEAT ROPE
(x1)

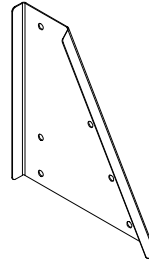

A4M01481 | A-FRAME BRACKET-RT
(x2)

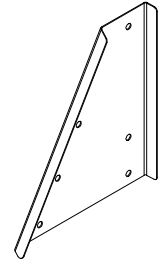

A4M01482 | A-FRAME BRACKET-LT
(x2)

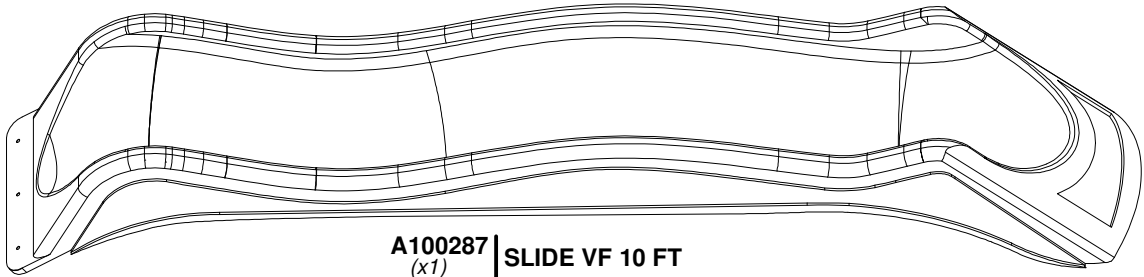

A100287 | SLIDE VF 10 FT
(x1)

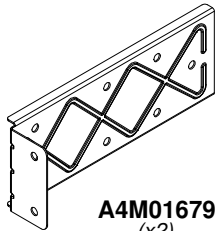

A4M01679 | EXTENDED SWING BEAM BRACKET
(x2)

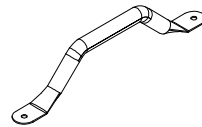

A100118 | HAND GRIP METAL GREEN 381 c/c
(x5)

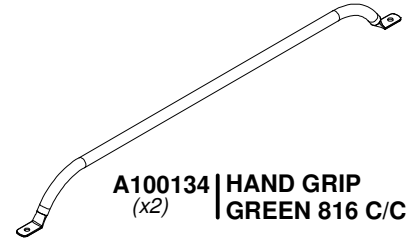

A100134 | HAND GRIP GREEN 816 C/C
(x2)

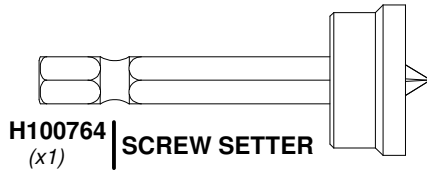

H100764 | SCREW SETTER
(x1)

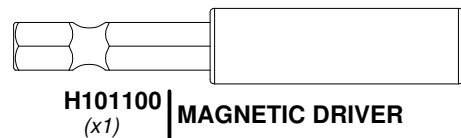

H101100 | MAGNETIC DRIVER
(x1)

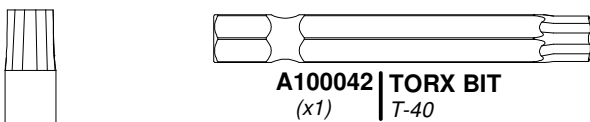

A100042 | TORX BIT T-40
(x1)

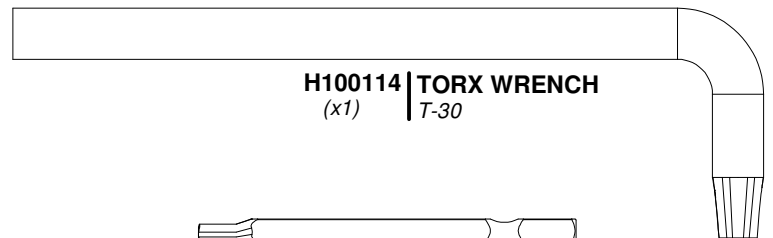

H100114 | TORX WRENCH T-30
(x1)

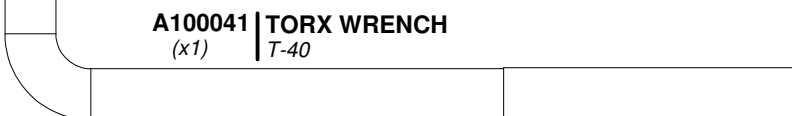

A100041 | TORX WRENCH T-40
(x1)

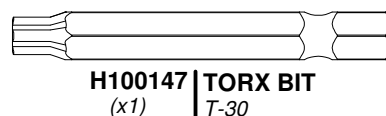

H100147 | TORX BIT T-30
(x1)

PRE-ASSEMBLY STEP 1 - SORTING PARTS

It is critical for ease of assembly that you take the time to sort and organize the wood and hardware.

WOOD PARTS:

- Organize wood parts by the three-digit, alpha-numeric number stamped on each board (ex. P01).
- If there are multiple boards with the same stamped number, stack those pieces together.
- Stamps can be found on the flat surface of the boards or on the end of the boards.
- Allow yourself plenty of room - the wood pieces can take up a significant amount of space.

NOTE: CARTONS ARE NOT ORGANIZED BY BOARD NUMBER.

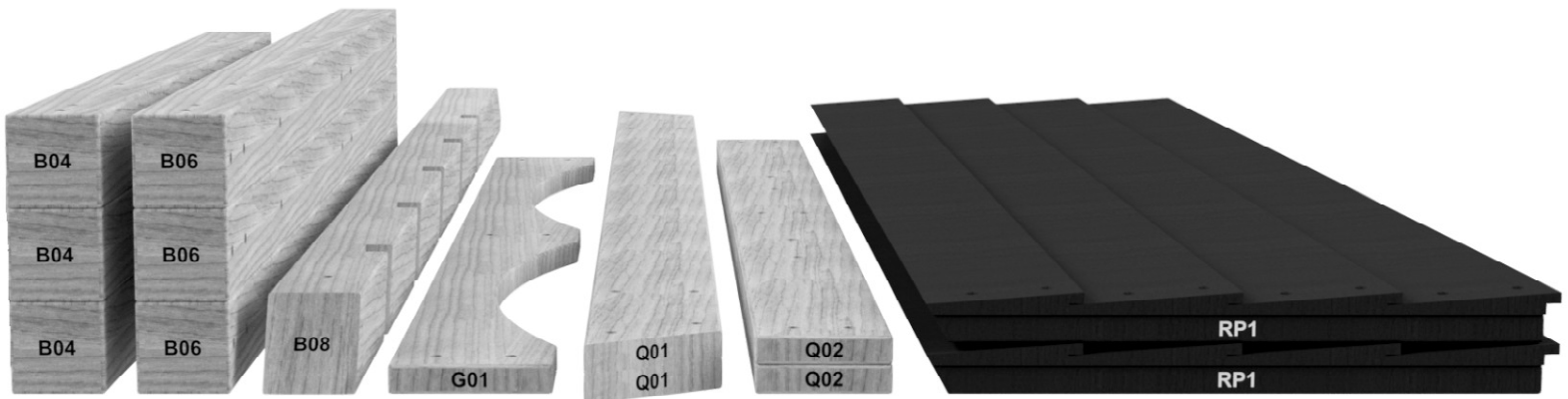

HARDWARE PARTS:

- We recommend that you have a separate table to organize the hardware.
- Hardware bags are printed with a seven-digit, alpha-numeric part number.
- You can organize your hardware by part number or group by hardware type (i.e. bolts, nuts, etc.).
- During assembly you only need to reference the last four digits of the number.

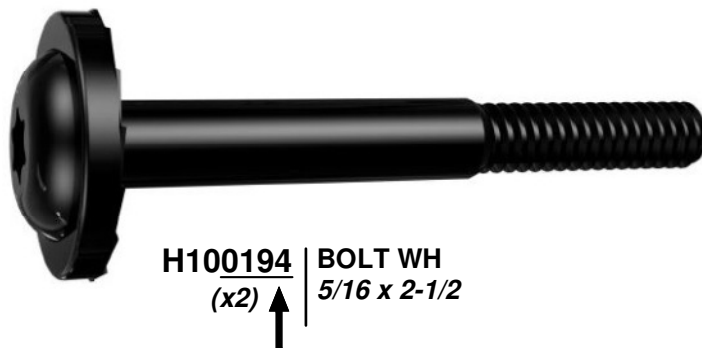

PRE-ASSEMBLY STEP 2 - TOOLS REQUIRED



Cordless Drill or
Electric Drill



Drill Attachments:
Phillips Head



1/8", 3/16", 3/8" & 7/16"
Drill Bits



Phillips Screw Driver



Open End Wrenches 1/2" & 9/16"



3/8" Drive Ratchet, 1/2" &
9/16" STD Sockets 1/2" & 9/16"
Deep Sockets



Claw Hammer



Rubber Mallet - Optional



Tape Measure

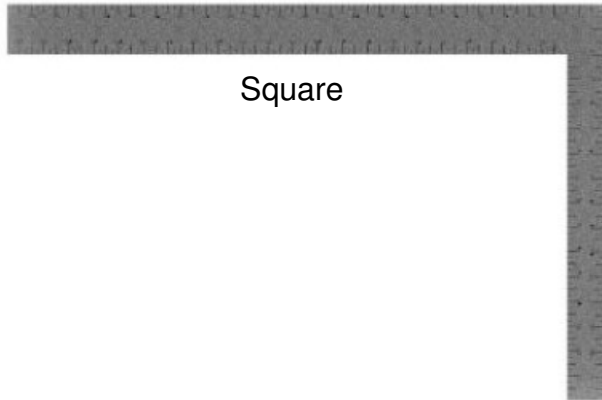

Square





Level 24"

PRE-ASSEMBLY STEP 3 - CHOOSE YOUR ASSEMBLY METHOD



There are several types of assembly instructions available to you.

1. Printed Assembly Manual included with your set
2. BILT APP - 3D interactive instructions
3. Combination of the Printed Manual and BILT APP (Note: Step numbers can differ between the two methods)

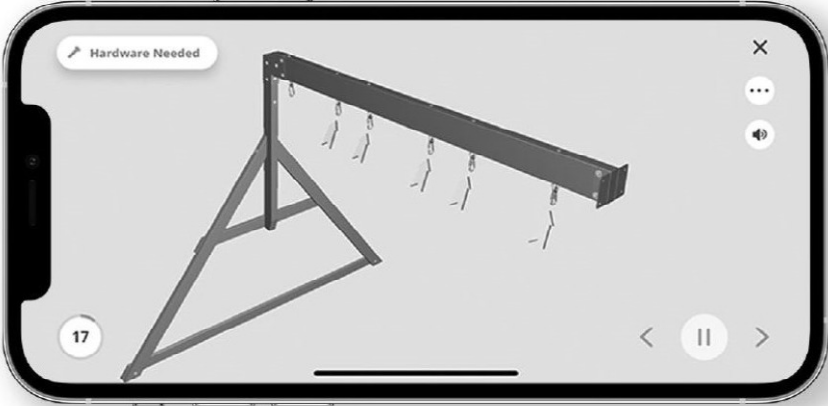

Scan for easy 3D instructions

Download the BILT app
before you begin



The image shows a smartphone screen displaying the BILT app interface. The screen features a 3D assembly diagram of a metal frame with a horizontal beam and several hanging components. The interface includes a 'Hardware Needed' button at the top left, a close button (X) at the top right, a menu button (three dots) and a volume icon below it, and a page number '17' in a circle at the bottom left. At the bottom center, there are navigation arrows and a pause button.

STEP 1 - PICNIC TABLE

QTY	PART NUMBER	DESCRIPTION
8	H100015	BOLT WH 5/16x2 3/4
8	H100030	WASHER LOCK EXT 8x19
8	H100074	T-NUT 5/16

F05 | UPPER SUPPORT - W4L16470
 (x2) | 1 3/8"x2 3/8"x16 3/4" (36x60x424)

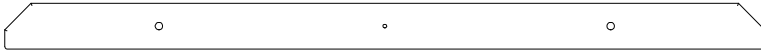

F08 | LEG SUPPORT - W4L16472
 (x2) | 1 3/8"x2 3/8"x39 5/8" (36x60x1006)

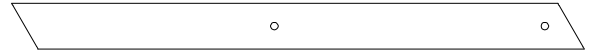

F06 | LEG - W4L16471
 (x4) | 1 3/8"x2 3/8"x29 7/8" (36x60x757)

TIP:
INSTALL T-NUTS IN WOOD FIRST

BUILD (2) LEG ASSEMBLIES

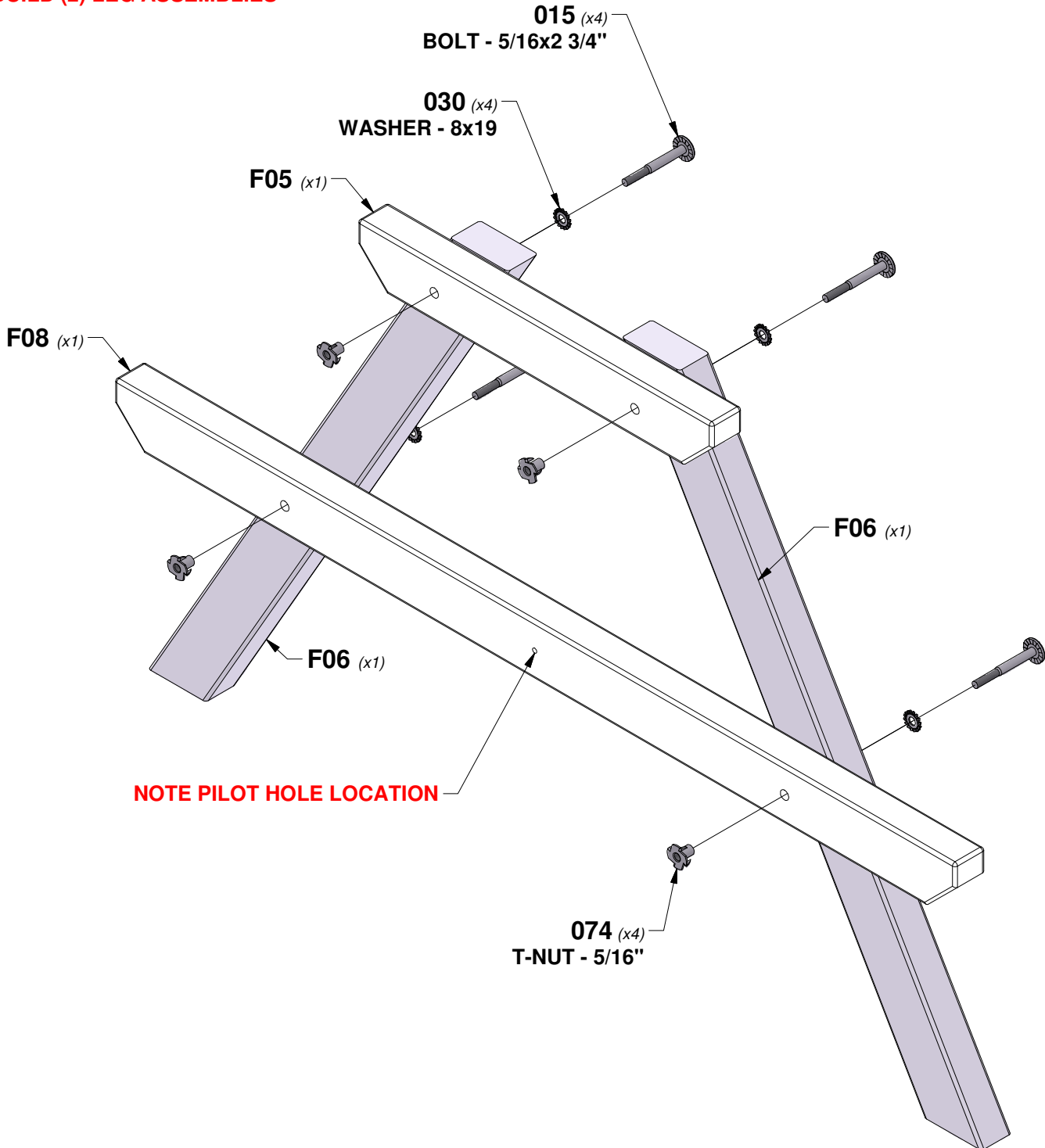

STEP 2 - PICNIC TABLE

QTY	PART NUMBER	DESCRIPTION
4	H100089	SCREW PFH 8x1-3/4"
4	H100091	SCREW PFH 8x2 1/4"

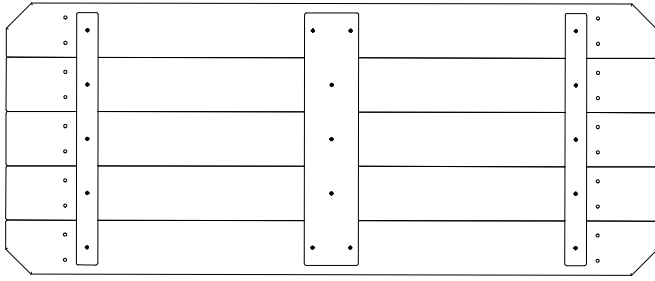

TP1 | PICNIC TABLE TOP - W2A03413
 (x1) | 1 7/8"x16 15/16"x40 11/16" (48x430x1034)



F12 | ANGLE BRACE - W4L16473
 (x2) | 1 3/8"x2 3/8"x20" (36x60x507)



E05 | BLOCK - W4L16474
 (x1) | 1 3/8"x3 3/8"x4 3/4" (36x86x120)

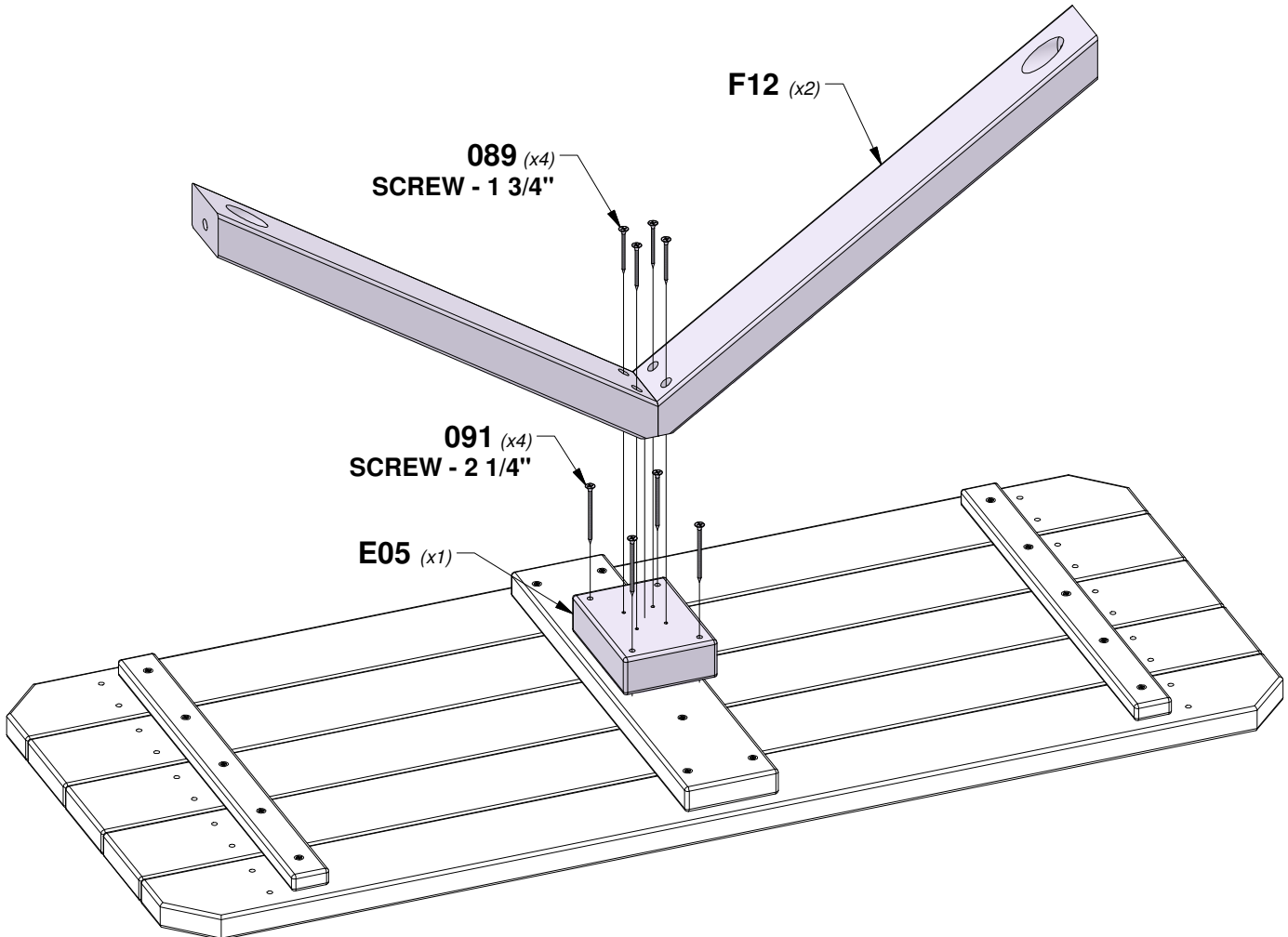
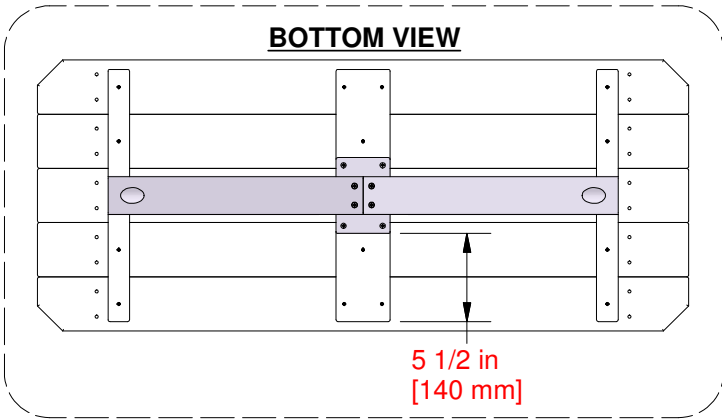

STEP 3 - PICNIC TABLE

QTY	PART NUMBER	DESCRIPTION
2	H100027	LAG SCREW WH 5/16x2
2	H100030	WASHER LOCK EXT 8x19
20	H100089	SCREW PFH 8x1-3/4"

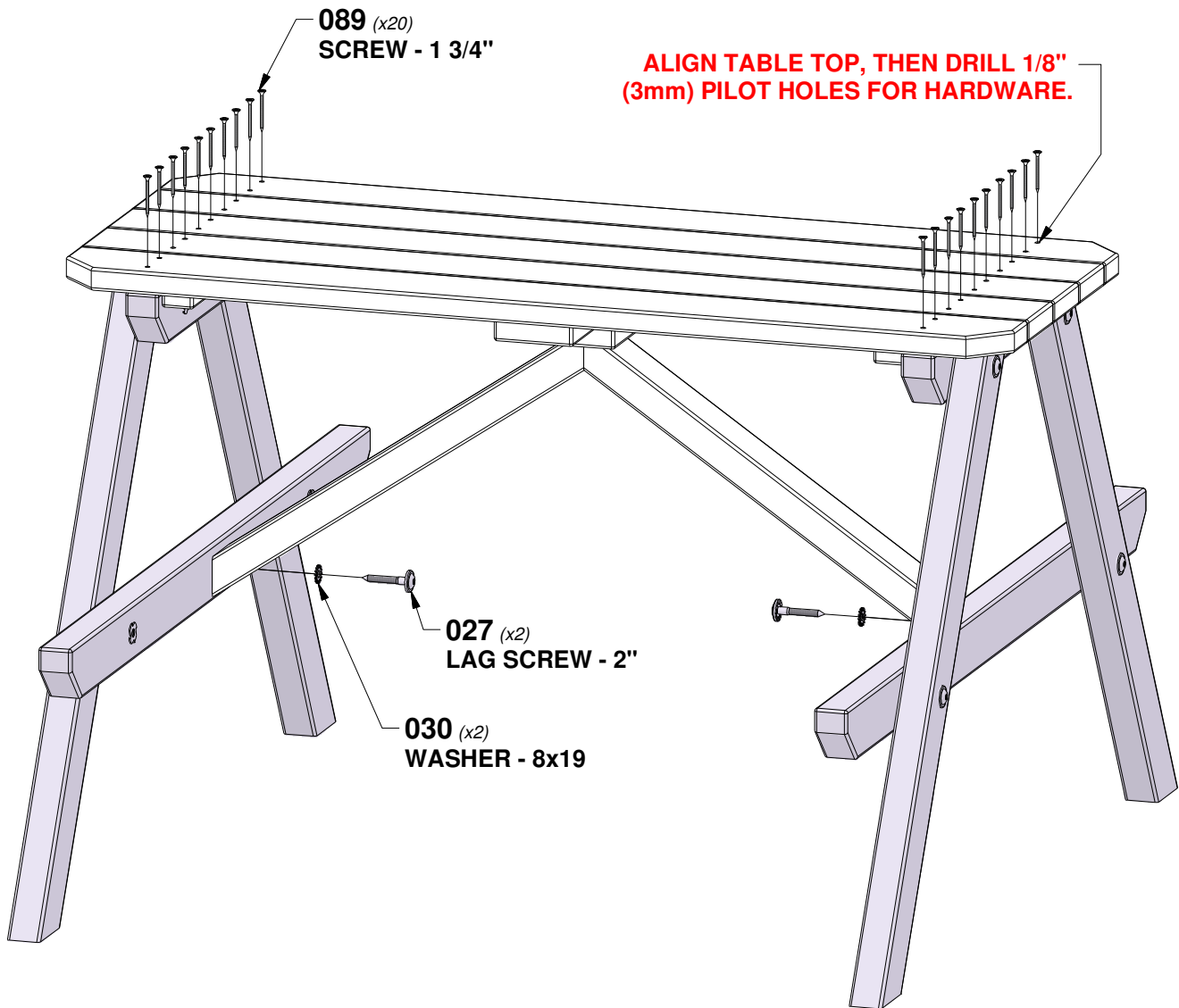
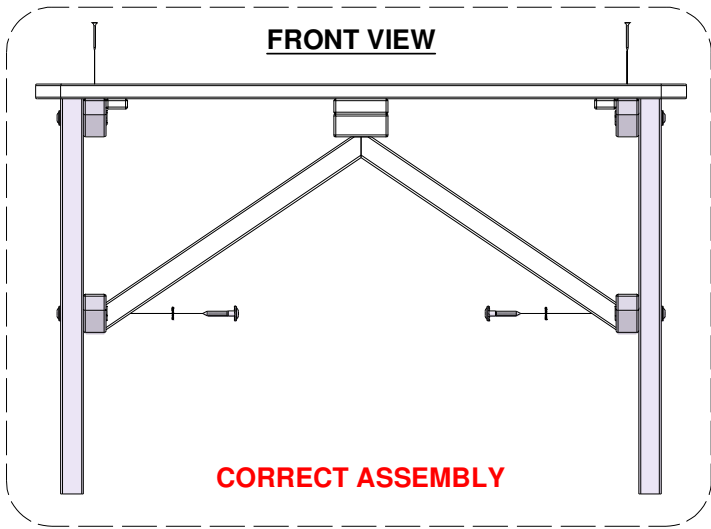

STEP 4 - PICNIC TABLE

QTY	PART NUMBER	DESCRIPTION
16	H100089	SCREW PFH 8x1-3/4"



TP2 | PICNIC TABLE SEAT - W2A03414
 (x2) | 1 9/16"x6 3/4"x40 11/16" (40x172x1034)

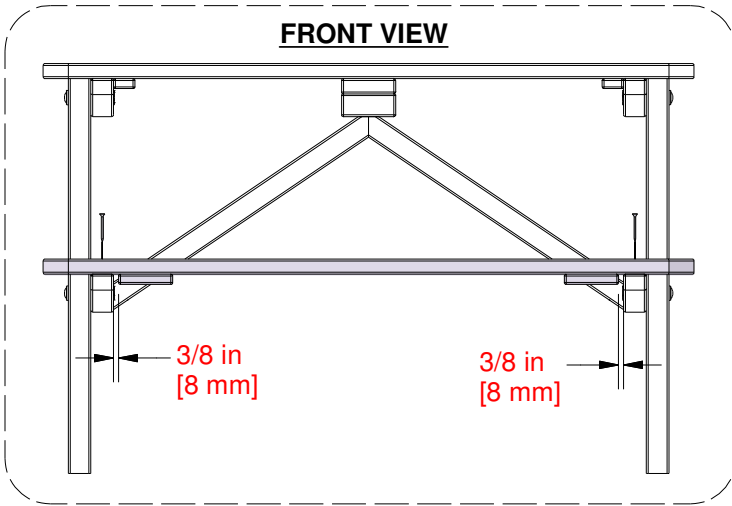

ALIGN TABLE SEATS, THEN DRILL 1/8" (3mm) PILOT HOLES FOR HARDWARE.

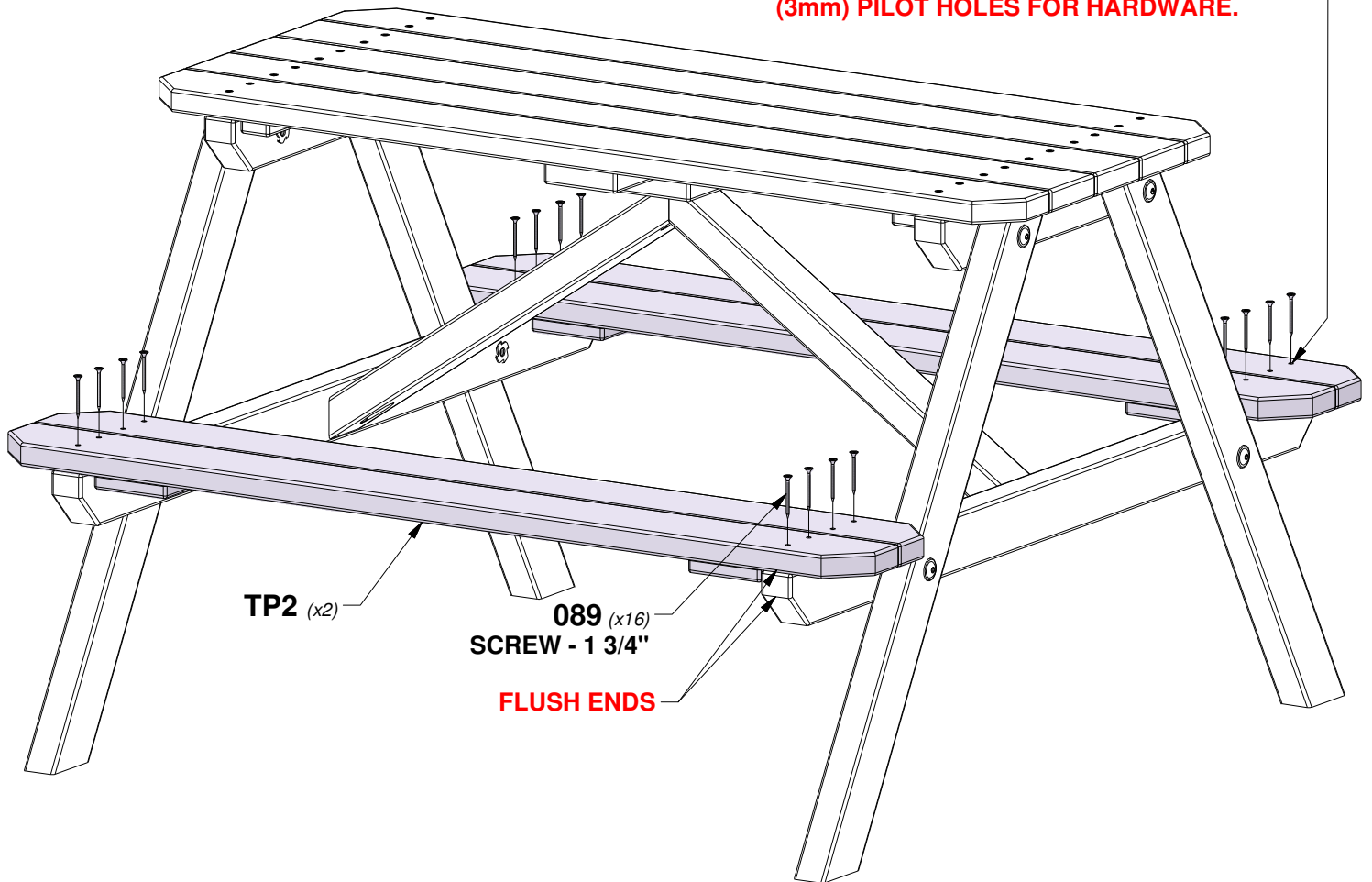

STEP 1 - SWING BEAM ASSEMBLY

QTY	PART NUMBER	DESCRIPTION
10	H100192	NUT BARREL WH 5/16x7/8 BLK
10	H100416	BOLT WH 5/16x3 BLK

A50 | SWING BEAM 2 POSITION - W4L16461
(x1) 3 3/8"x5 1/4"x89 1/2" (86x134x2274)

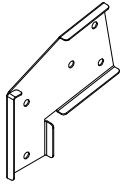

A4M00617 | SWING BEAM
EXTENSION
BRACKET-LEFT
(x1)

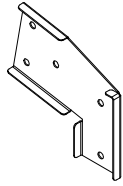

A4M00618 | SWING BEAM
EXTENSION
BRACKET-RIGHT
(x1)

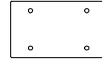

A2 | SB 9" BLOCK - W4L16459
(x1) 3 3/8"x5 1/4"x9" (86x134x228)

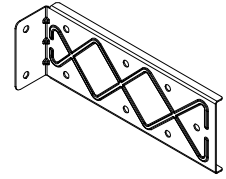

A4M01679 | EXTENDED
SWING BEAM
BRACKET
(x2)

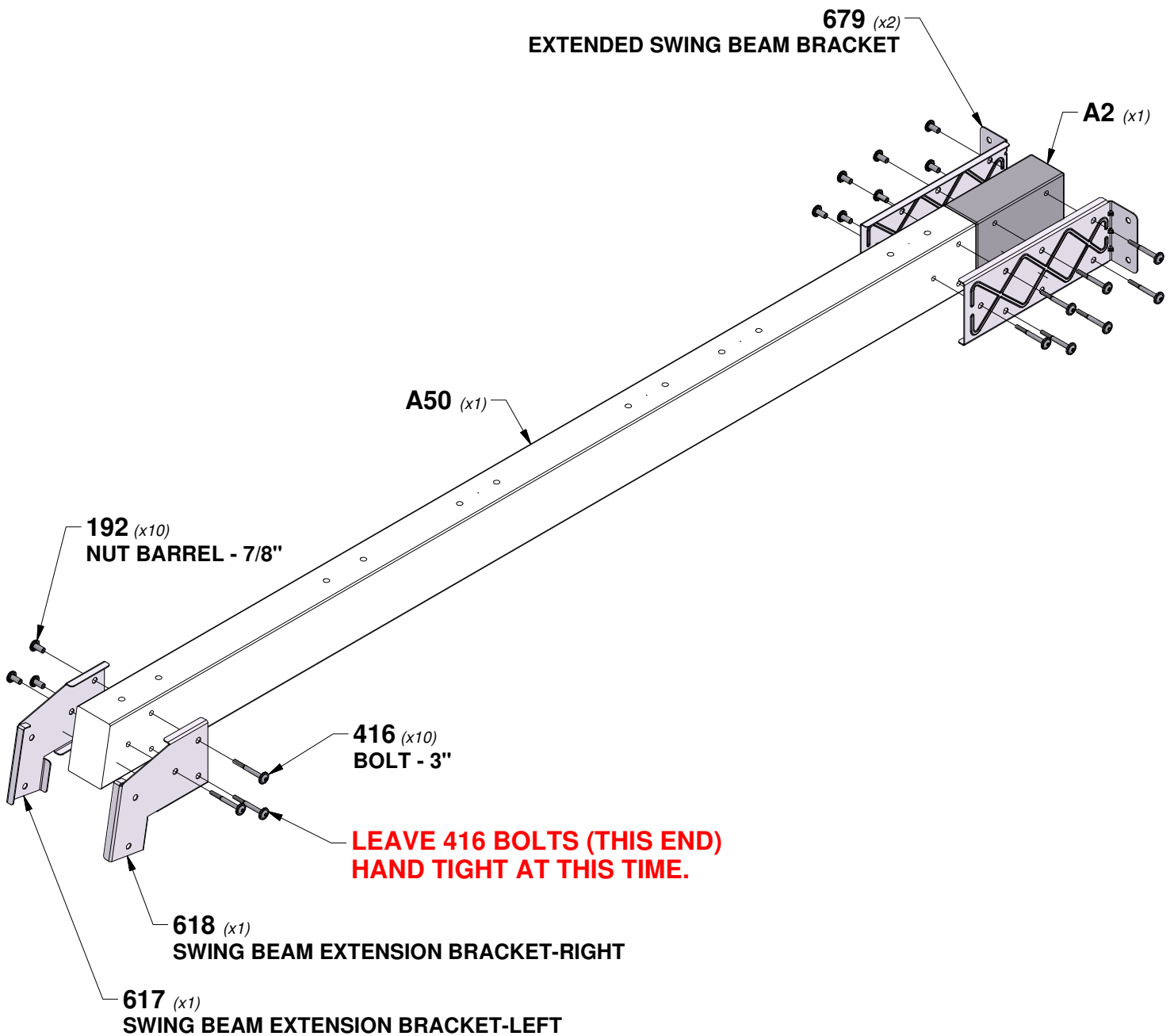

STEP 2 - SWING BEAM ASSEMBLY

QTY	PART NUMBER	DESCRIPTION
12	H100073	T-NUT 3/8
12	H100102	WASHER FLAT 11x25
12	H100107	WASHER LOCK INT 10x18
12	H100654	BOLT HEX 3/8x5-1/2

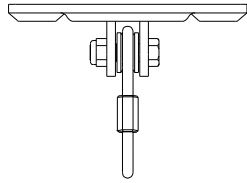

A4M00505
(x6) | SWING HANGER

TIP:
INSTALL T-NUTS IN WOOD FIRST

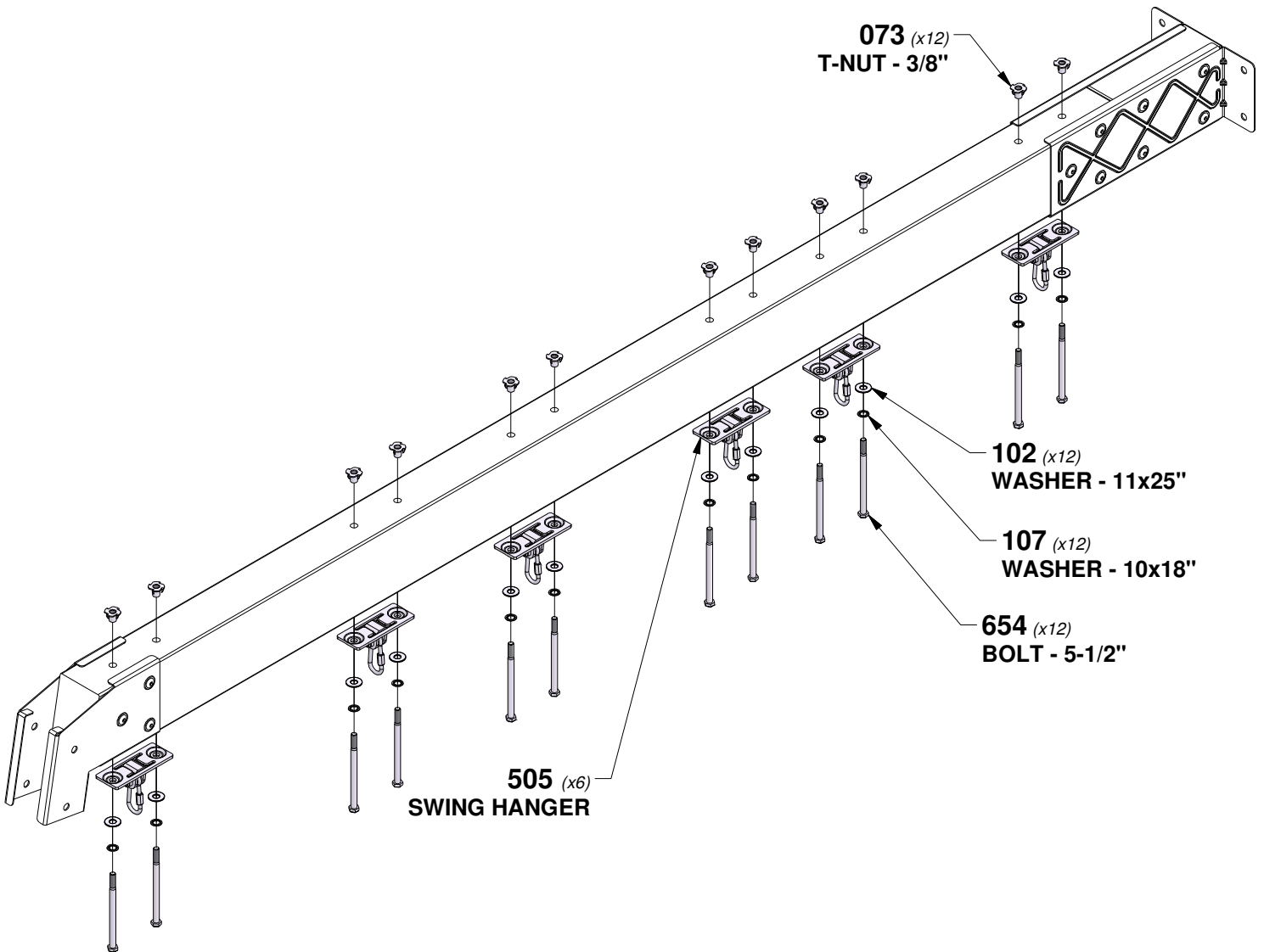

STEP 3 - SWING BEAM ASSEMBLY

QTY	PART NUMBER	DESCRIPTION
4	H100070	SCREW PWH 8x3/4



A100164 BYD ID TAG
(x1) (LARGE) AGES
3-10

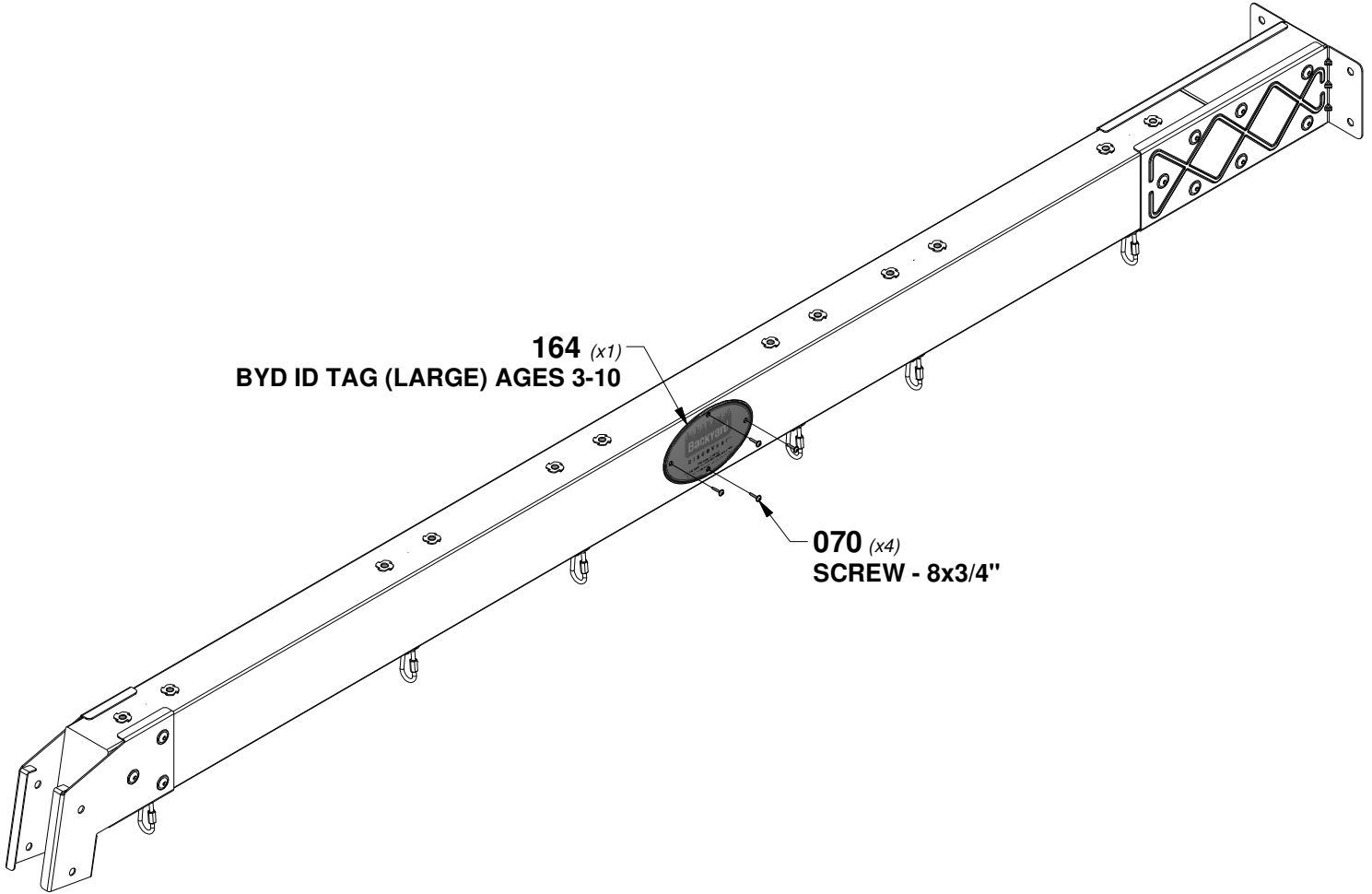

STEP 4 - SWING BEAM ASSEMBLY

QTY	PART NUMBER	DESCRIPTION
6	H100379	T-NUT 5/16 BLK
4	H100416	BOLT WH 5/16x3 BLK
2	H100503	BOLT WH 5/16x3-1/2 BLK



SP01 | SWING BEAM SUPPORT - W4L16462
(x1) | 3 3/8"x3 3/8"x50" (86x86x1269)

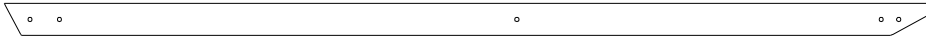

B50 | ANGLE BRACE - W4L16463
(x2) | 3"x3"x87 1/8" (76x76x2212)

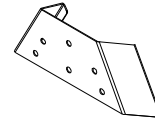

A4M01498 | A-FRAME BRACKET
(x1)

TIP:
INSTALL T-NUTS IN WOOD FIRST

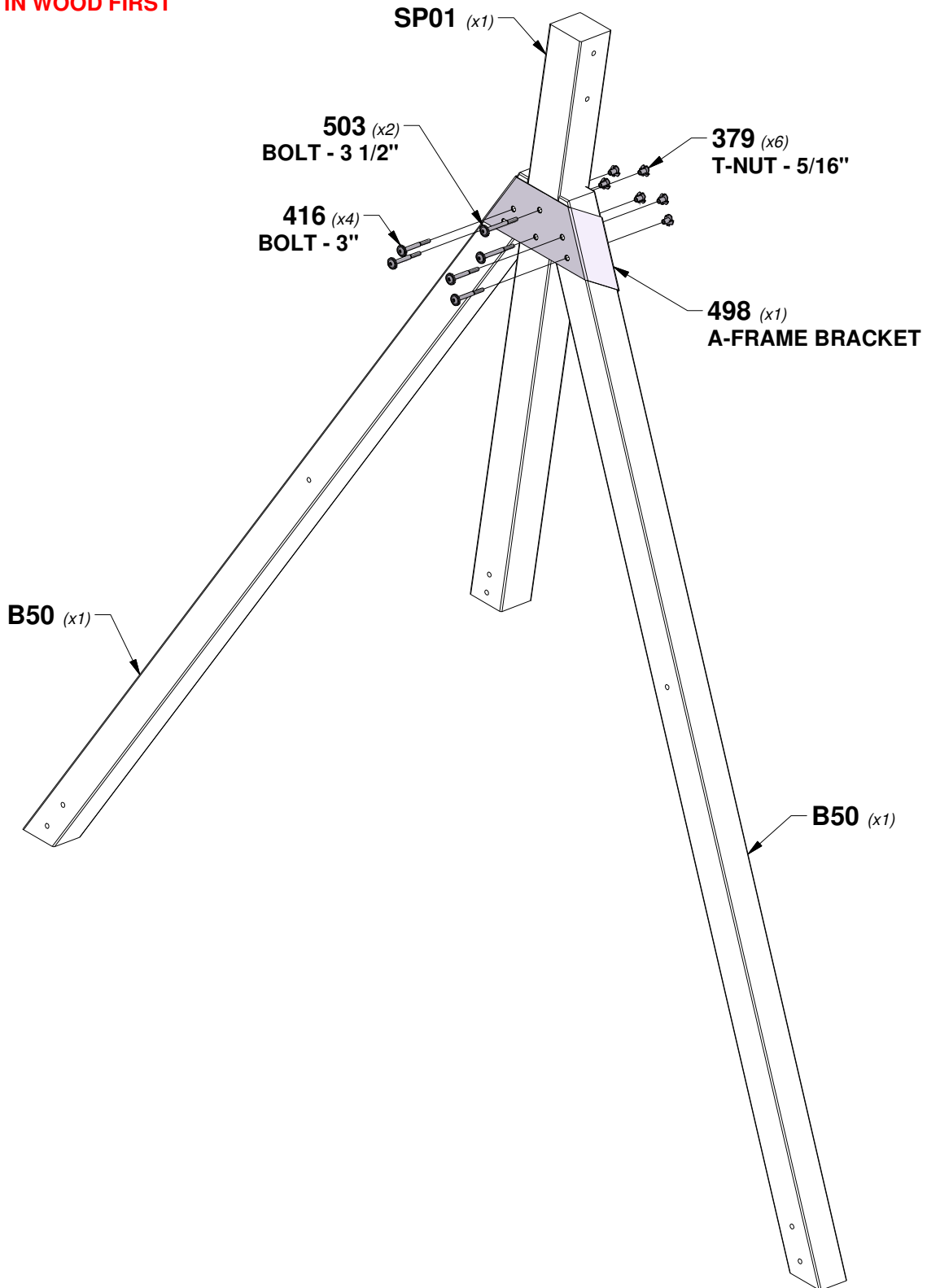

STEP 5 - SWING BEAM ASSEMBLY

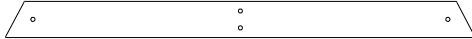

E50 | END SUPPORT - W4L16464
(x1) | 1 3/8"x3 3/8"x44 1/8" (36x86x1120)



G50 | GROUND BOARD - W4L16465
(x1) | 1"x5 1/4"x86 3/4" (24x134x2202)

QTY	PART NUMBER	DESCRIPTION
4	H100019	BOLT WH 5/16x3 3/4
8	H100030	WASHER LOCK EXT 8x19
8	H100074	T-NUT 5/16
2	H100166	BOLT WH 5/16x4 1/4
2	H100505	BOLT WH 5/16x4 3/4

TIP:
INSTALL T-NUTS IN WOOD FIRST

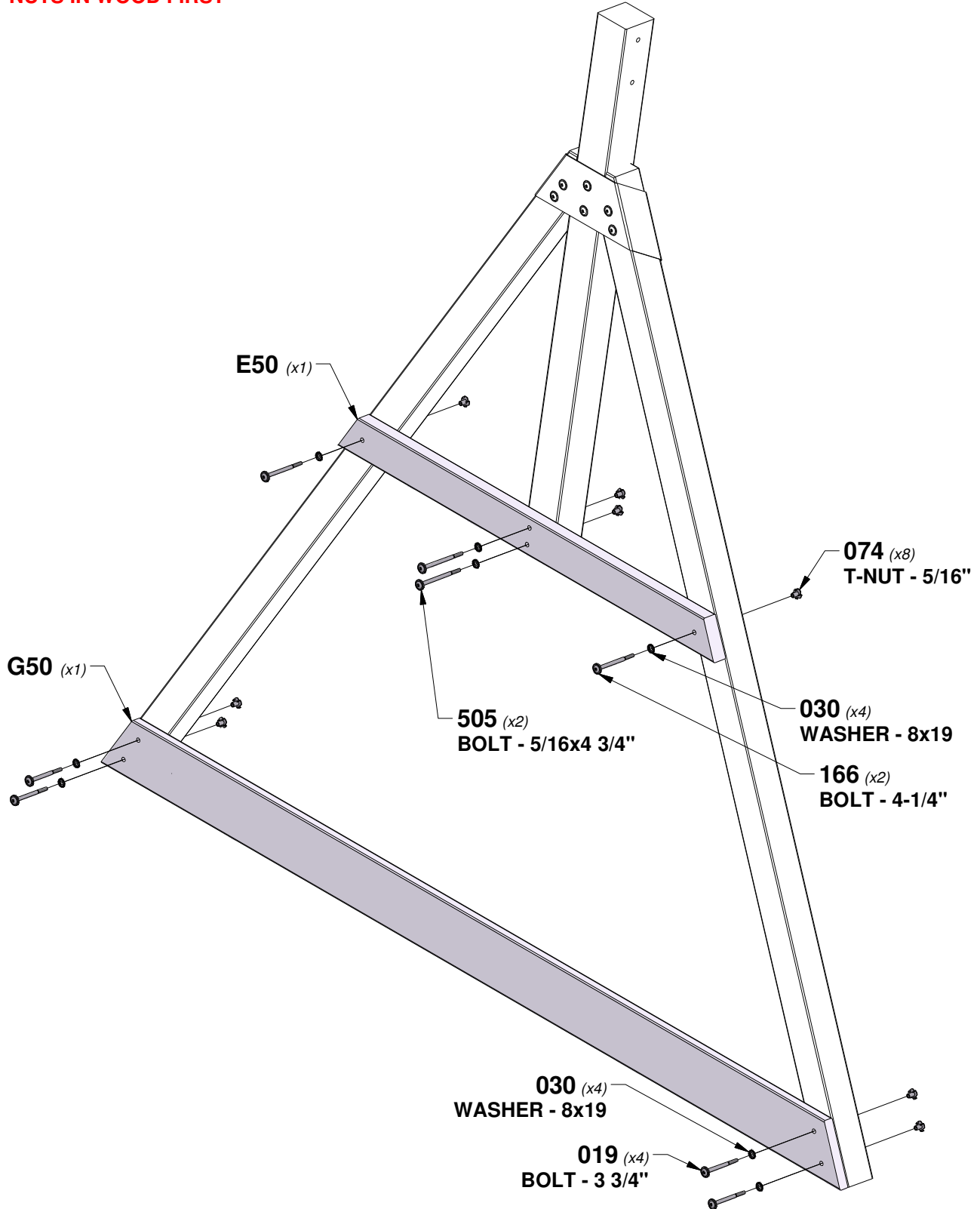

STEP 6 - SWING BEAM ASSEMBLY

QTY	PART NUMBER	DESCRIPTION
2	H100192	NUT BARREL WH 5/16x7/8 BLK
2	H100416	BOLT WH 5/16x3 BLK

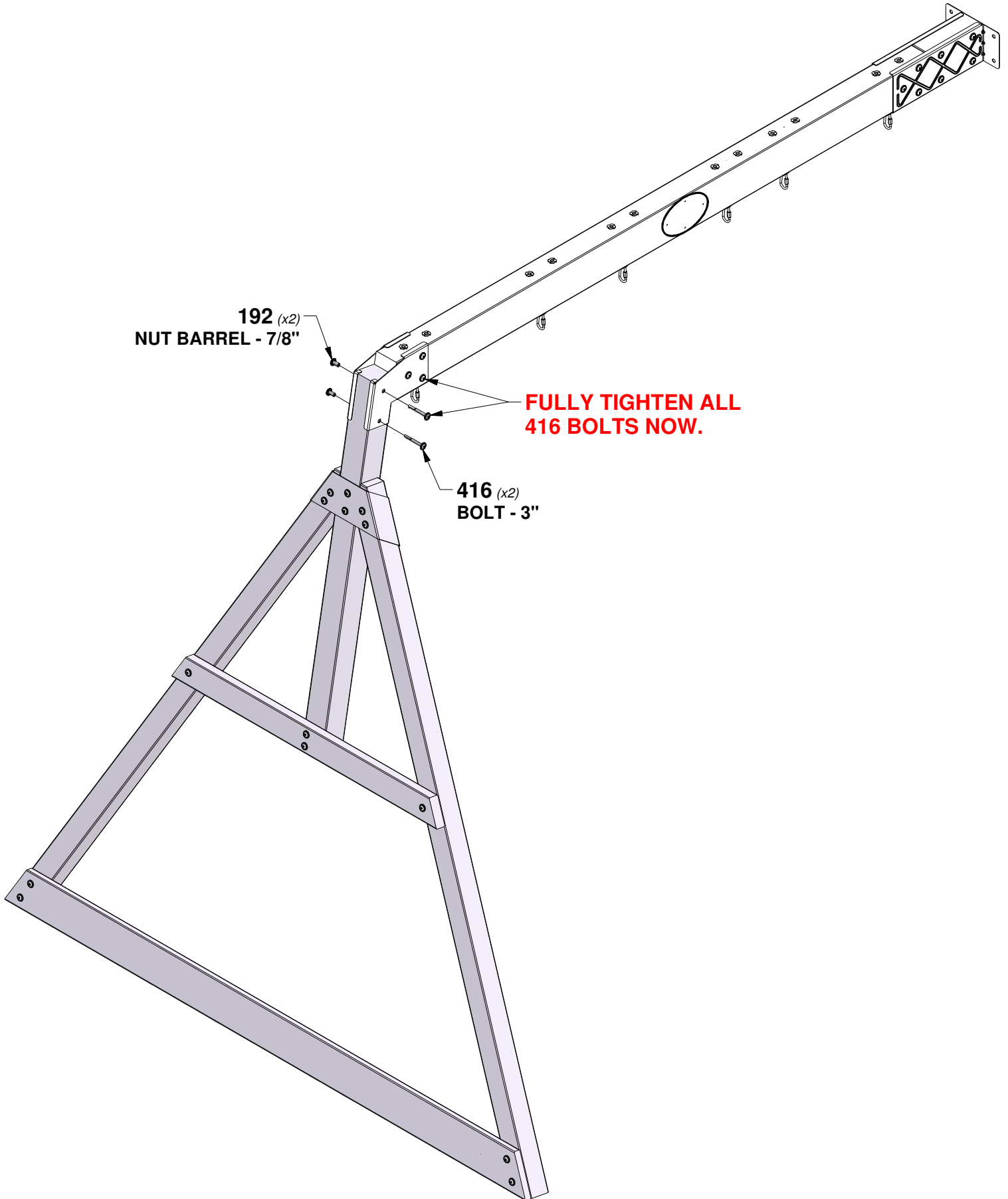

STEP 1 - FORT ASSEMBLY

QTY	PART NUMBER	DESCRIPTION
10	H100019	BOLT WH 5/16x3 3/4
14	H100030	WASHER LOCK EXT 8x19
20	H100074	T-NUT 5/16
4	H100166	BOLT WH 5/16x4-1/4
2	H100416	BOLT WH 5/16x3 BLK



G04 | WALL RAIL - W4L16443
(x1) | 1"x5 1/4"x50 3/8" (24x134x1280)

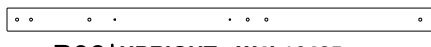

B06 | UPRIGHT - W4L16425
(x2) | 3"x3"x55 1/2" (76x76x1410)



H08 | WALL RAIL - W4L16454
(x1) | 1"x3 3/8"x52 1/4" (24x86x1328)



D01 | WALL RAIL - W4L16426
(x1) | 1 3/8"x5 1/4"x50 3/8" (36x134x1280)



Q01 | FLOOR RAIL - W4L16173
(x1) | 1"x4 3/8"x67 5/8" (24x112x1718)

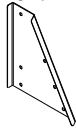

A4M01481 | A-FRAME
BRACKET-RT
(x1)

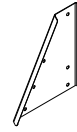

A4M01482 | A-FRAME
BRACKET-LT
(x1)

TIP:
INSTALL T-NUTS IN WOOD FIRST

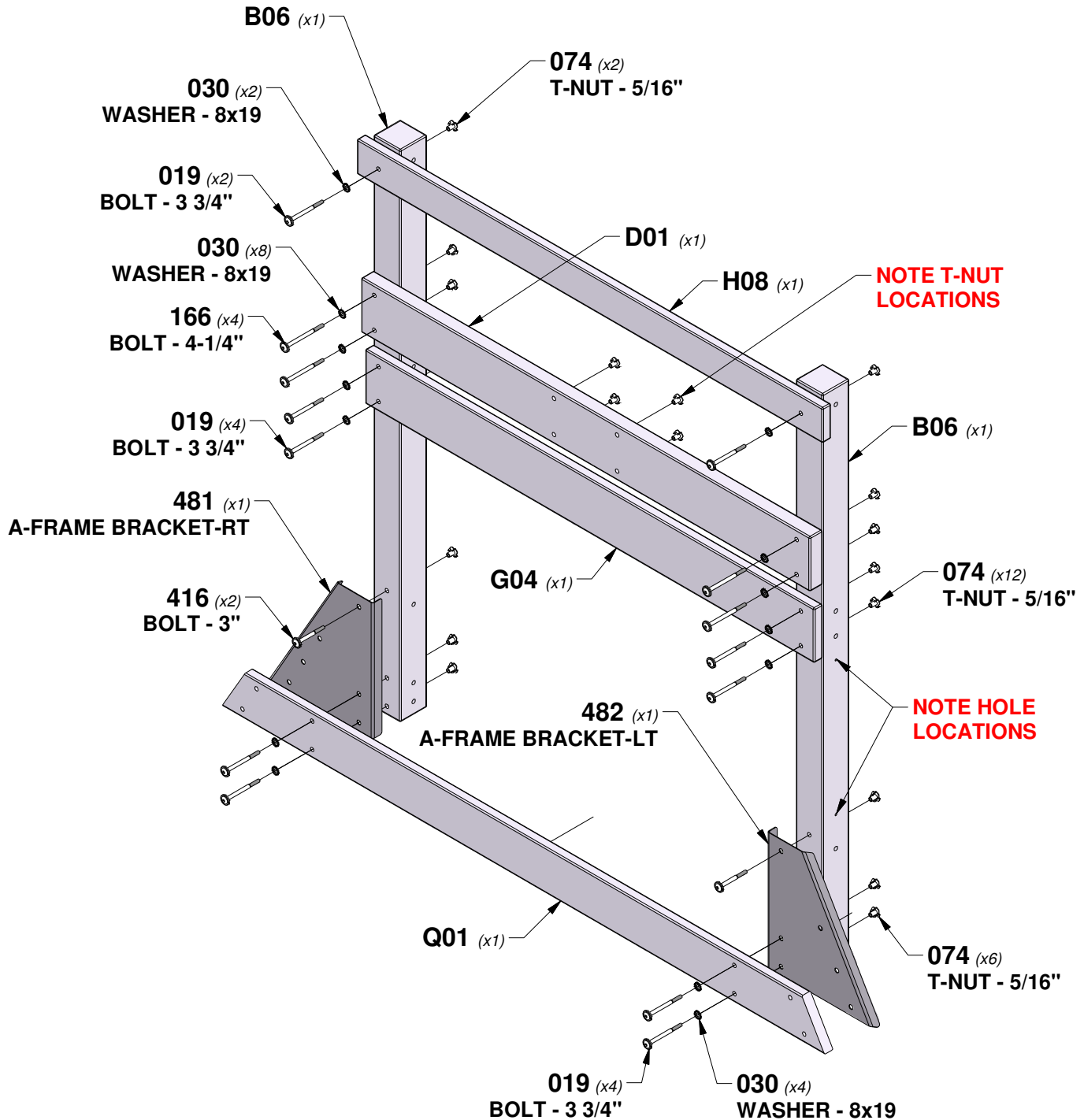

STEP 2 - FORT ASSEMBLY

QTY	PART NUMBER	DESCRIPTION
4	H100019	BOLT WH 5/16x3 3/4
2	H100022	BOLT WH 5/16x5
6	H100030	WASHER LOCK EXT 8x19
6	H100074	T-NUT 5/16

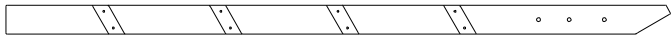

B13 | LEG - W4L16476
(x1) | 3"x3"x69 1/4" (76x76x1760)

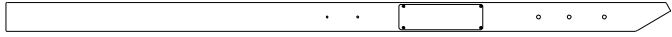

B03 | LEG - W2A03278
(x1) | 3"x3"x79 3/8" (76x76x2015)

TIP:
INSTALL T-NUTS IN WOOD FIRST

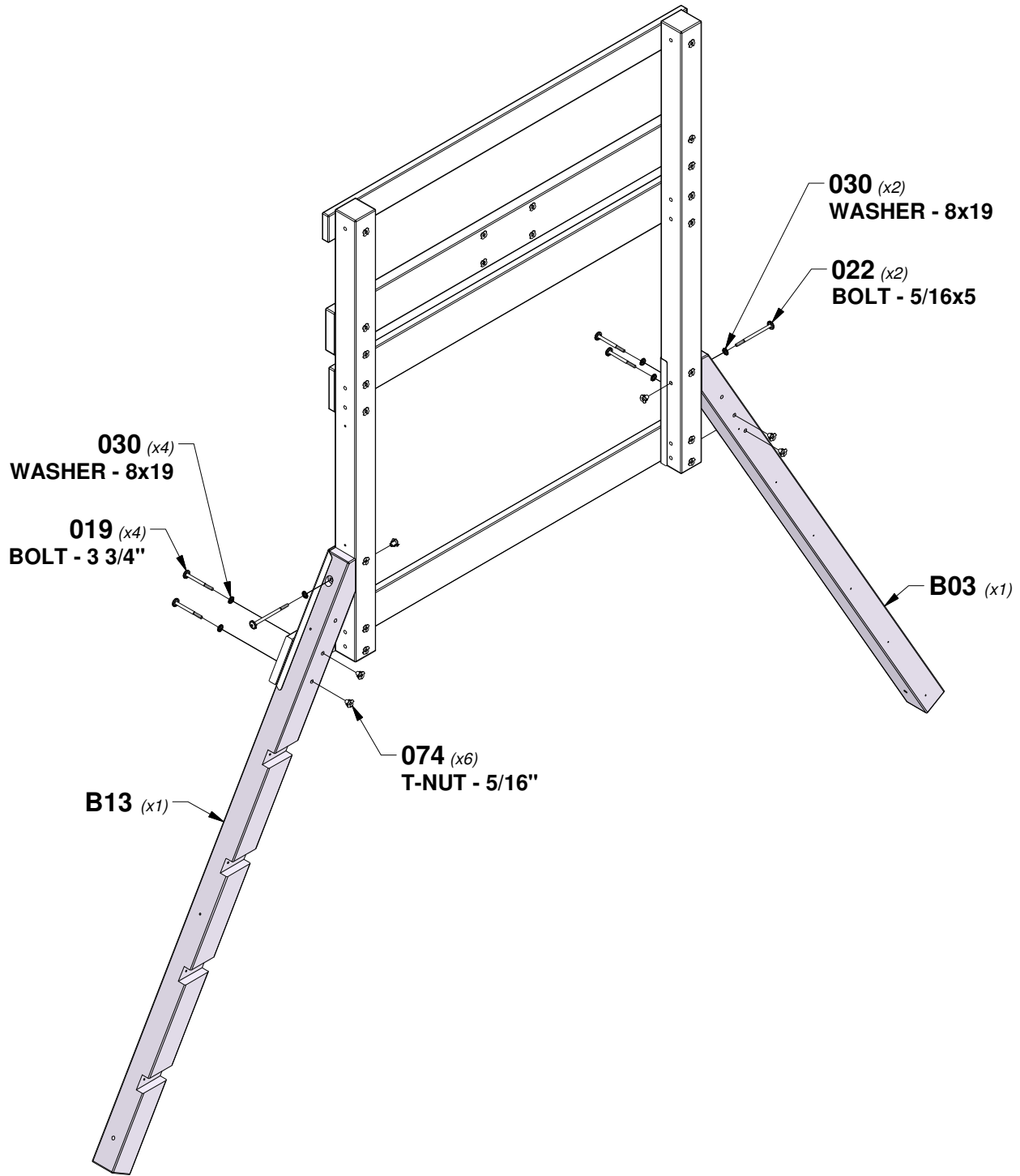

STEP 3 - FORT ASSEMBLY

QTY	PART NUMBER	DESCRIPTION
10	H100019	BOLT WH 5/16x3 3/4
10	H100030	WASHER LOCK EXT 8x19
12	H100074	T-NUT 5/16
2	H100416	BOLT WH 5/16x3 BLK

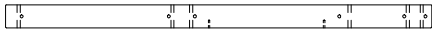

B10 UPRIGHT - W4L16435
(x2) 3"x3"x55 1/2" (76x76x1410)



G02 WALL RAIL - W4L16423
(x1) 1"x5 1/4"x50 3/8" (24x134x1280)



H08 WALL RAIL - W4L16454
(x1) 1"x3 3/8"x52 1/4" (24x86x1328)



Q01 FLOOR RAIL - W4L16173
(x1) 1"x4 3/8"x67 5/8" (24x112x1718)

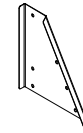

A4M01481 A-FRAME
(x1) BRACKET-RT

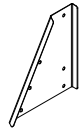

A4M01482 A-FRAME
(x1) BRACKET-LT

TIP:
INSTALL T-NUTS IN WOOD FIRST

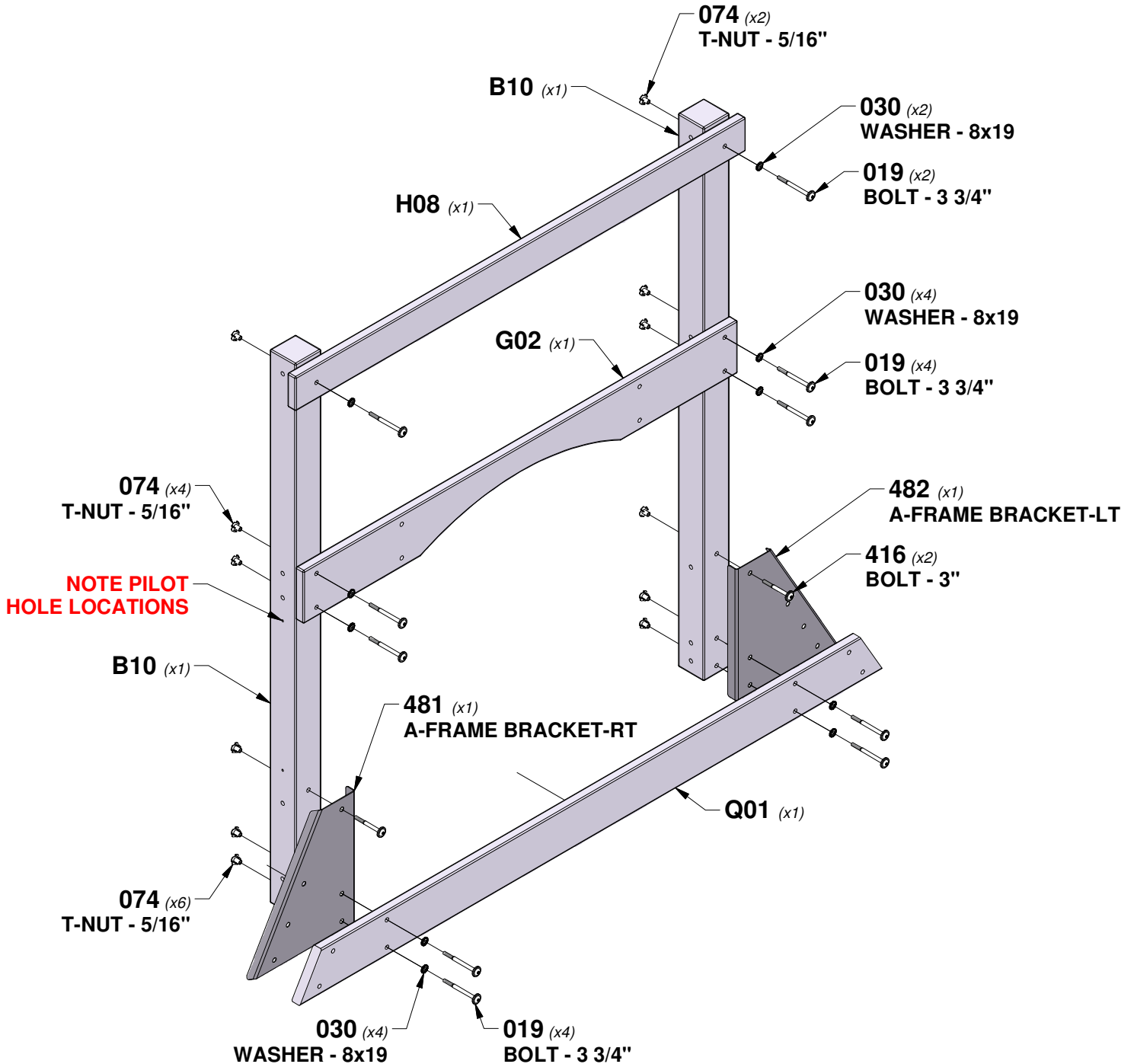

STEP 4 - FORT ASSEMBLY

QTY	PART NUMBER	DESCRIPTION
4	H100019	BOLT WH 5/16x3 3/4
2	H100022	BOLT WH 5/16x5
6	H100030	WASHER LOCK EXT 8x19
6	H100074	T-NUT 5/16

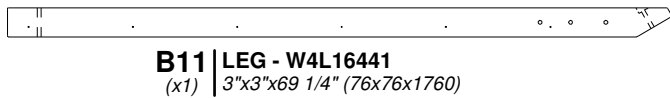
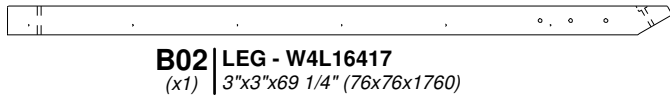

TIP:
INSTALL T-NUTS IN WOOD FIRST

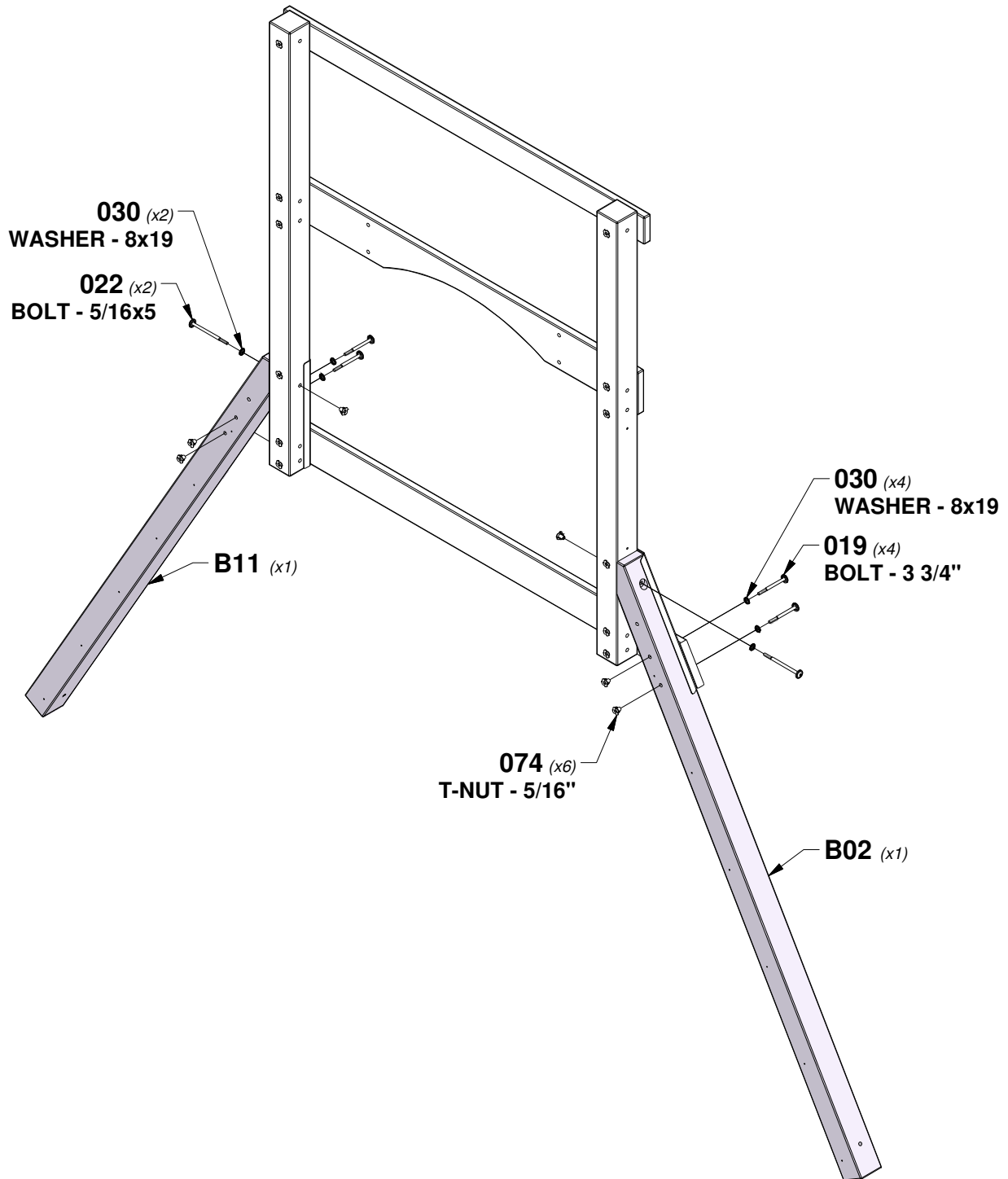

STEP 5 - FORT ASSEMBLY

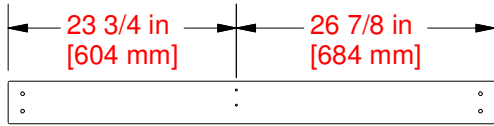

Q03 | FLOOR RAIL - W4L16421
 (x1) | 1"x4 3/8"x50 3/4" (24x112x1288)

QTY	PART NUMBER	DESCRIPTION
2	H100019	BOLT WH 5/16x3 3/4
2	H100030	WASHER LOCK EXT 8x19
2	H100074	T-NUT 5/16

TIP:
INSTALL T-NUTS IN WOOD FIRST

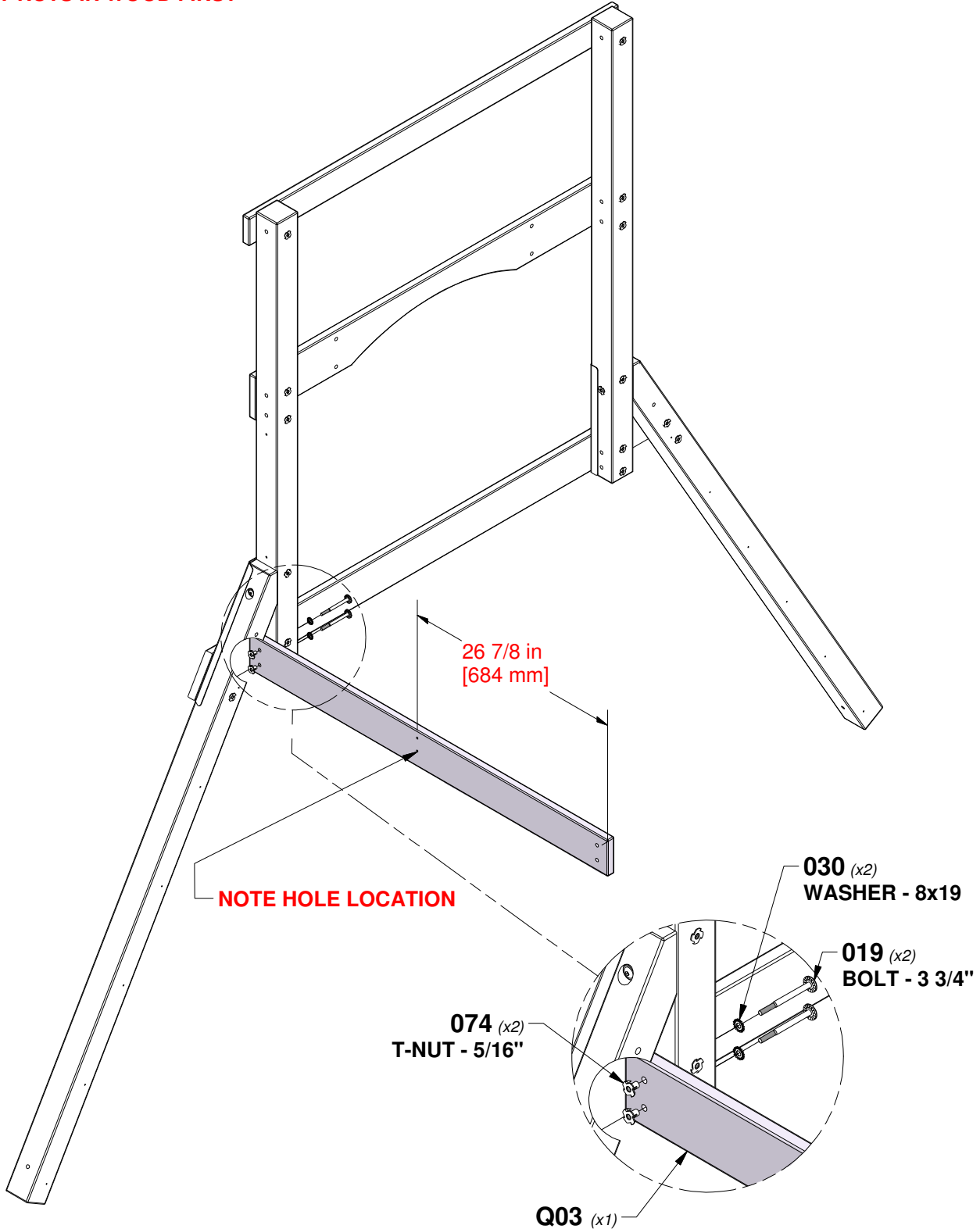

STEP 6 - FORT ASSEMBLY

QTY	PART NUMBER	DESCRIPTION
2	H100019	BOLT WH 5/16x3 3/4
2	H100030	WASHER LOCK EXT 8x19
2	H100074	T-NUT 5/16

TIP:
INSTALL T-NUTS IN WOOD FIRST

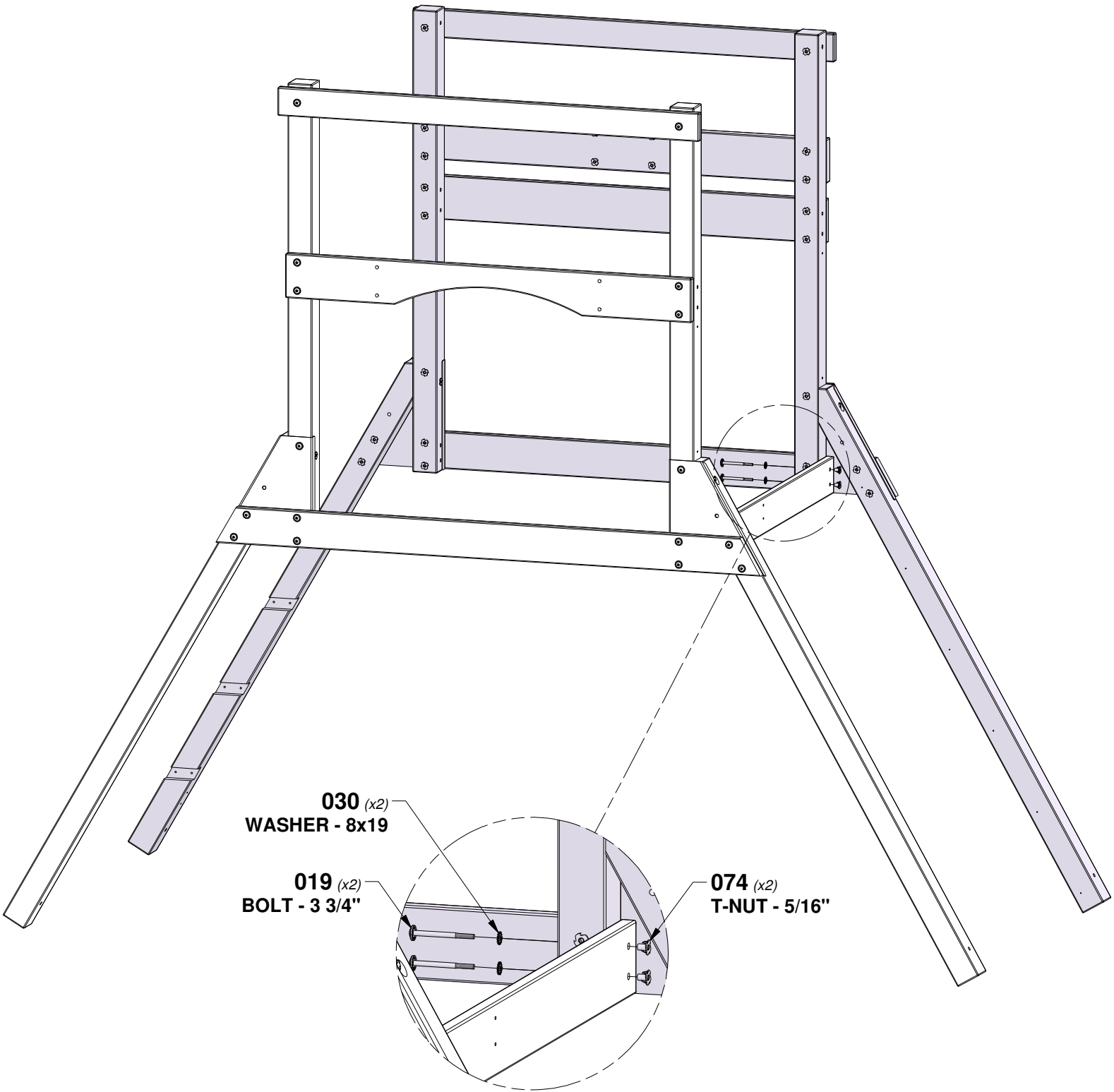

STEP 7 - FORT ASSEMBLY



Q02 | FLOOR RAIL - W4L16418
 (x1) | 1"x4 3/8"x50 3/4" (24x112x1288)

QTY	PART NUMBER	DESCRIPTION
4	H100019	BOLT WH 5/16x3 3/4
4	H100030	WASHER LOCK EXT 8x19
4	H100074	T-NUT 5/16

TIP:
INSTALL T-NUTS IN WOOD FIRST

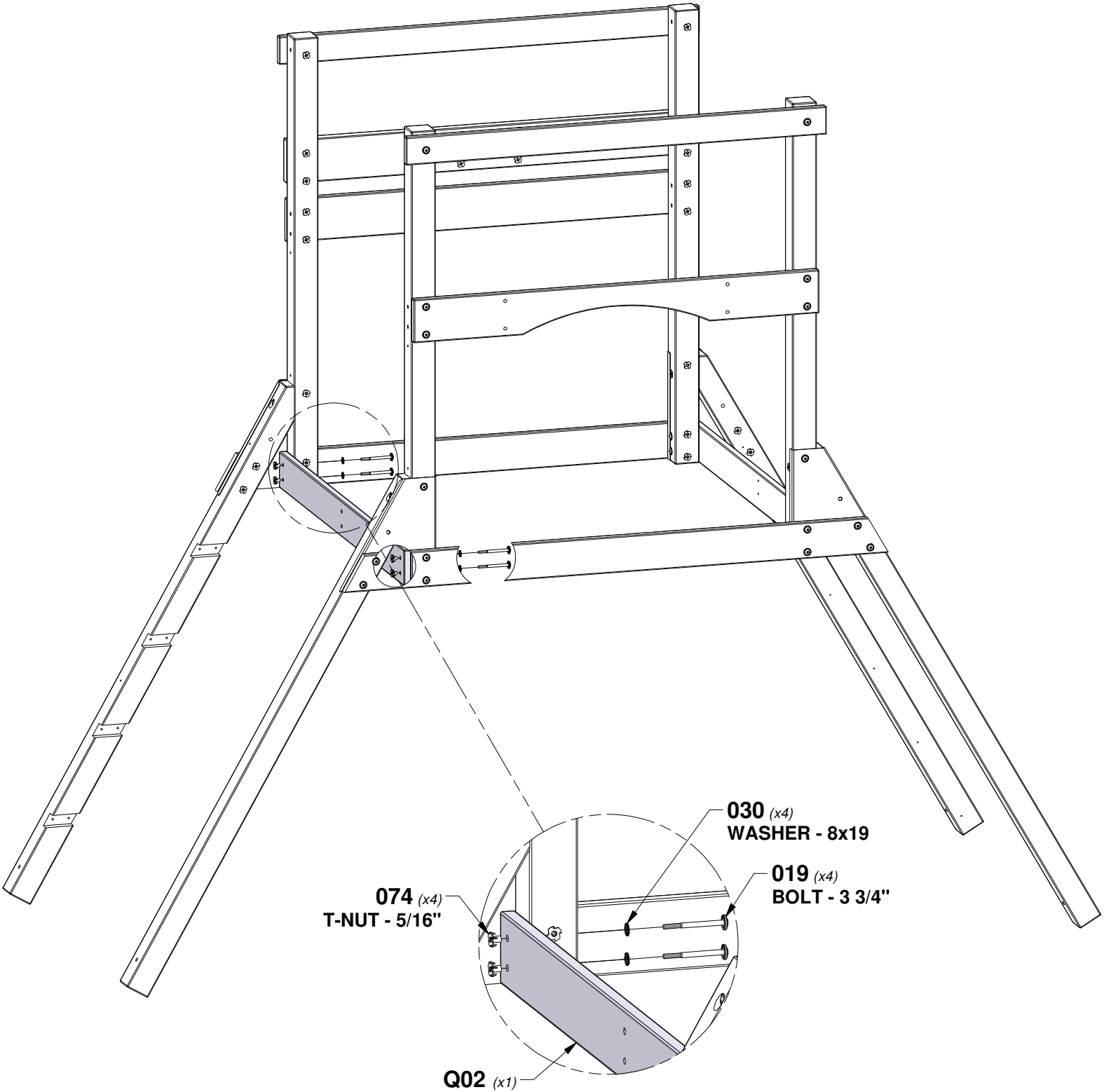

STEP 8 - FORT ASSEMBLY

QTY	PART NUMBER	DESCRIPTION
4	H100023	BOLT WH 5/16X6
4	H100030	WASHER LOCK EXT 8x19
4	H100074	T-NUT 5/16

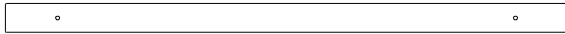

B12 | GROUND BOARD - W4L16446
(x1) | 3"x3"x58 5/8" (76x76x1488)



B07 | GROUND BOARD - W4L16427
(x1) | 3"x3"x58 5/8" (76x76x1488)

TIP:
INSTALL T-NUTS IN WOOD FIRST

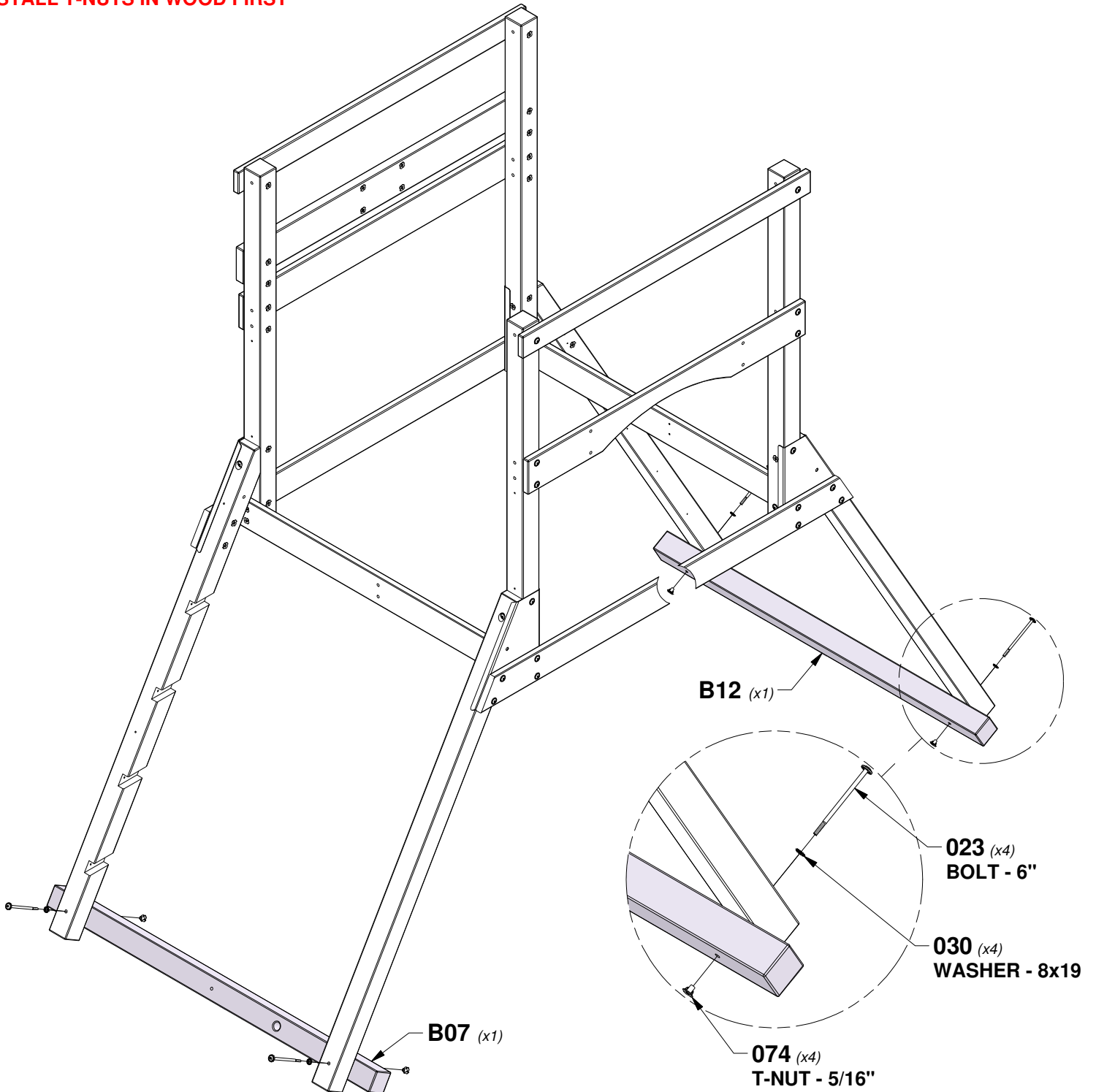

STEP 9 - FORT ASSEMBLY

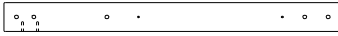

B04 UPRIGHT - W4L16419
(x1) | 3"x3"x35" (76x76x888)

QTY	PART NUMBER	DESCRIPTION
2	H100019	BOLT WH 5/16x3 3/4
2	H100030	WASHER LOCK EXT 8x19
2	H100074	T-NUT 5/16

TIP:
INSTALL T-NUTS IN WOOD FIRST

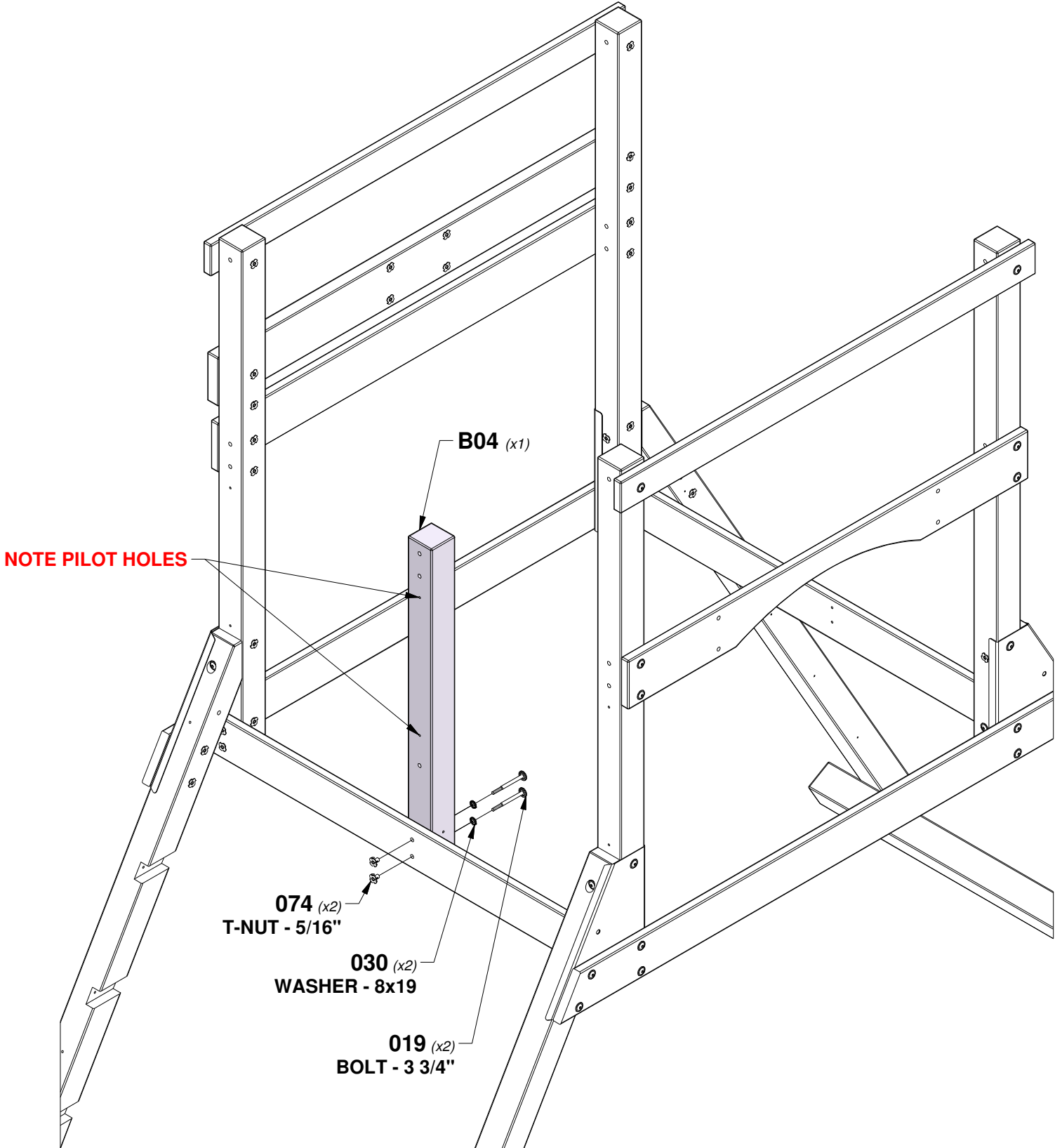

STEP 10 - FORT ASSEMBLY

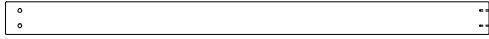

E01 | FLOOR JOIST - W4L16420
 (x1) | 1 3/8"x3 3/8"x50 3/8" (36x86x1280)

QTY	PART NUMBER	DESCRIPTION
2	H100029	LAG SCREW WH 5/16x3
2	H100030	WASHER LOCK EXT 8x19
2	H100092	SCREW PFH 8x3

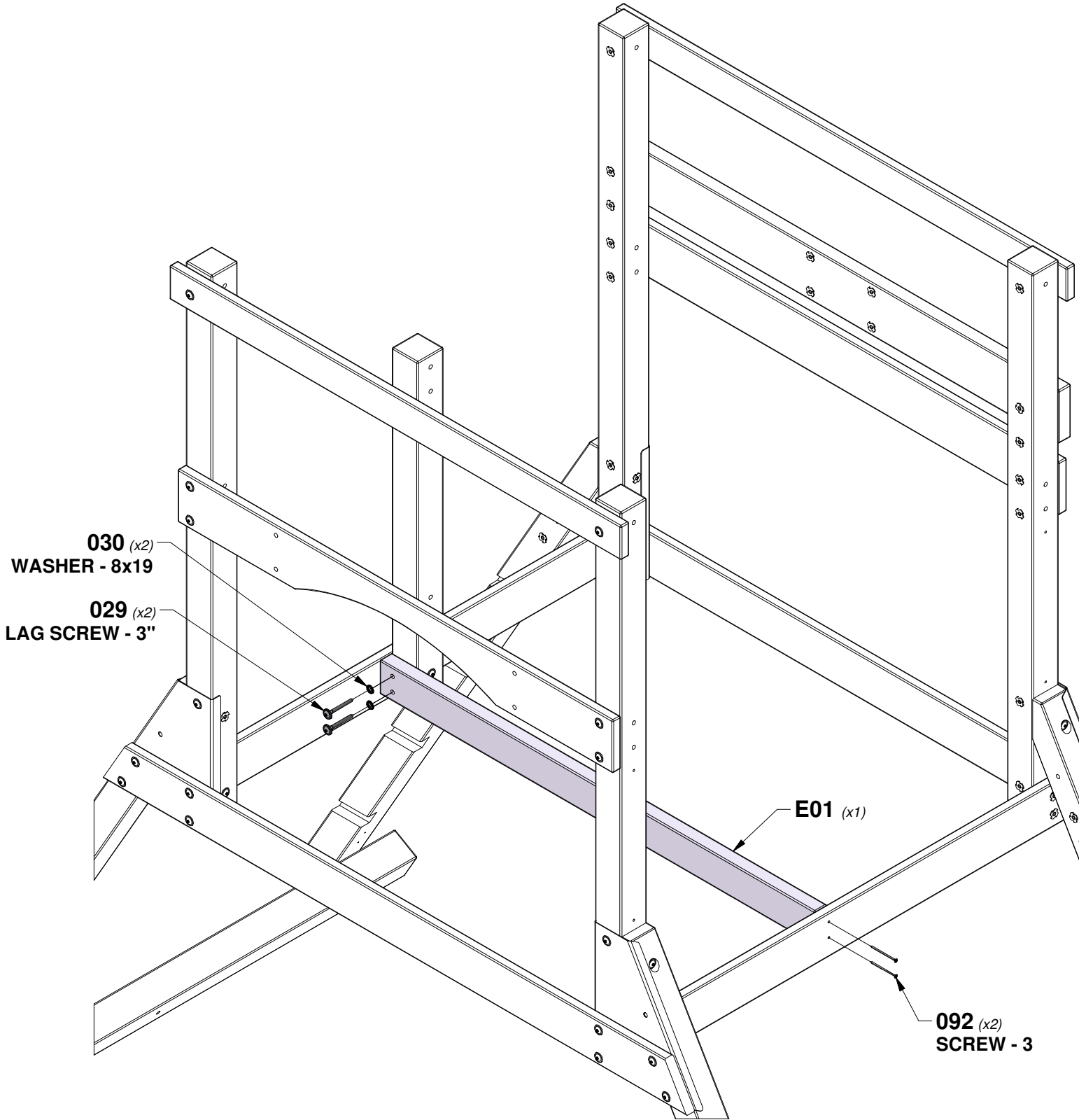

STEP 11 - FORT ASSEMBLY

QTY	PART NUMBER	DESCRIPTION
10	H100091	SCREW PFH 8x2 1/4



H03 FLOOR RAIL - W4L16430
(x5) 1"x3"x3 3/8" (24x76x86)

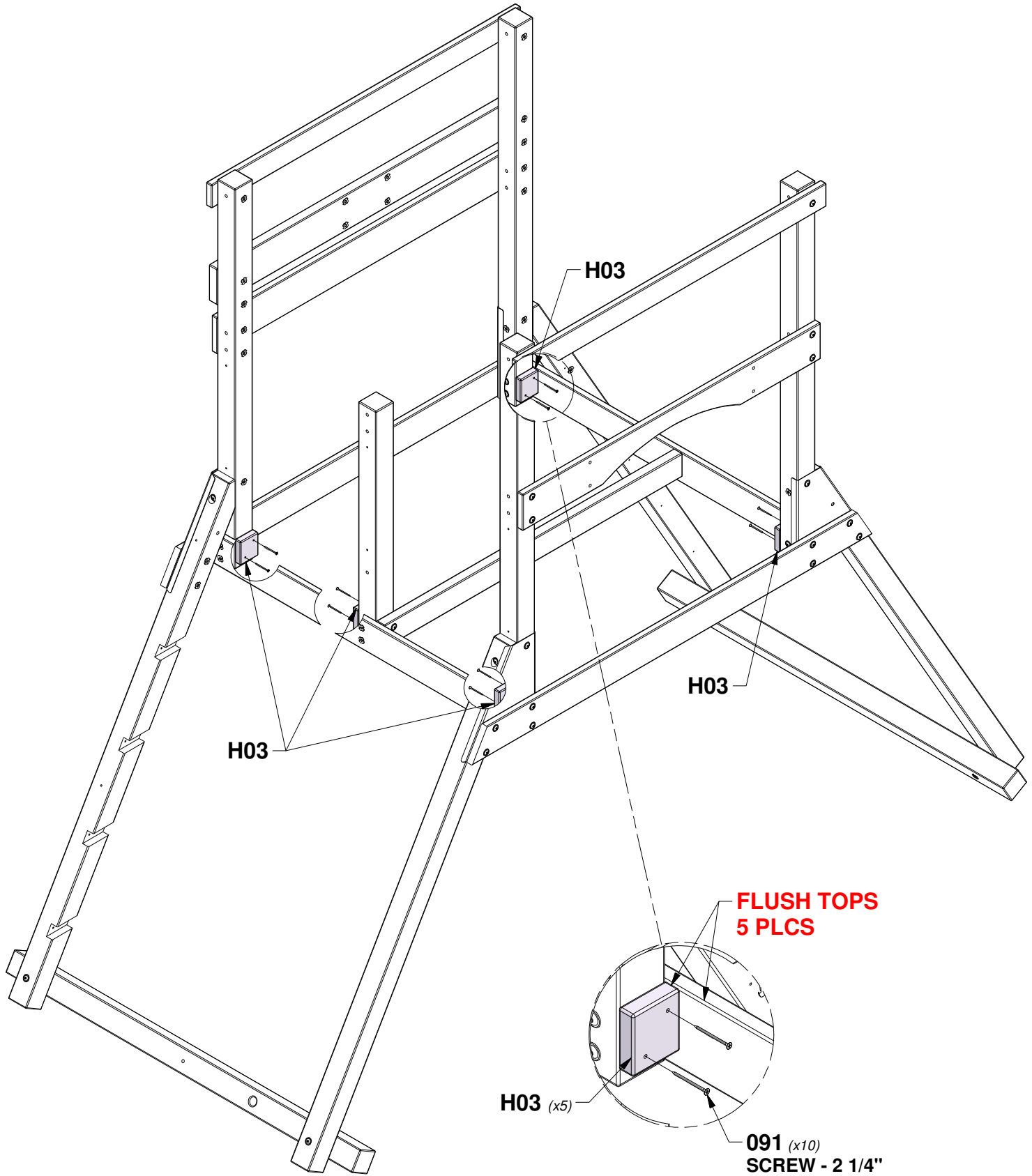

STEP 12 - FORT ASSEMBLY

QTY	PART NUMBER	DESCRIPTION
1	H100022	BOLT WH 5/16x5
1	H100023	BOLT WH 5/16X6
2	H100030	WASHER LOCK EXT 8x19
2	H100074	T-NUT 5/16

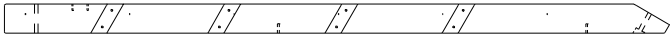

B08 | LEG - W4L16433
(x1) | 3"x3"x69 1/4" (76x76x1760)

TIP:
INSTALL T-NUTS IN WOOD FIRST

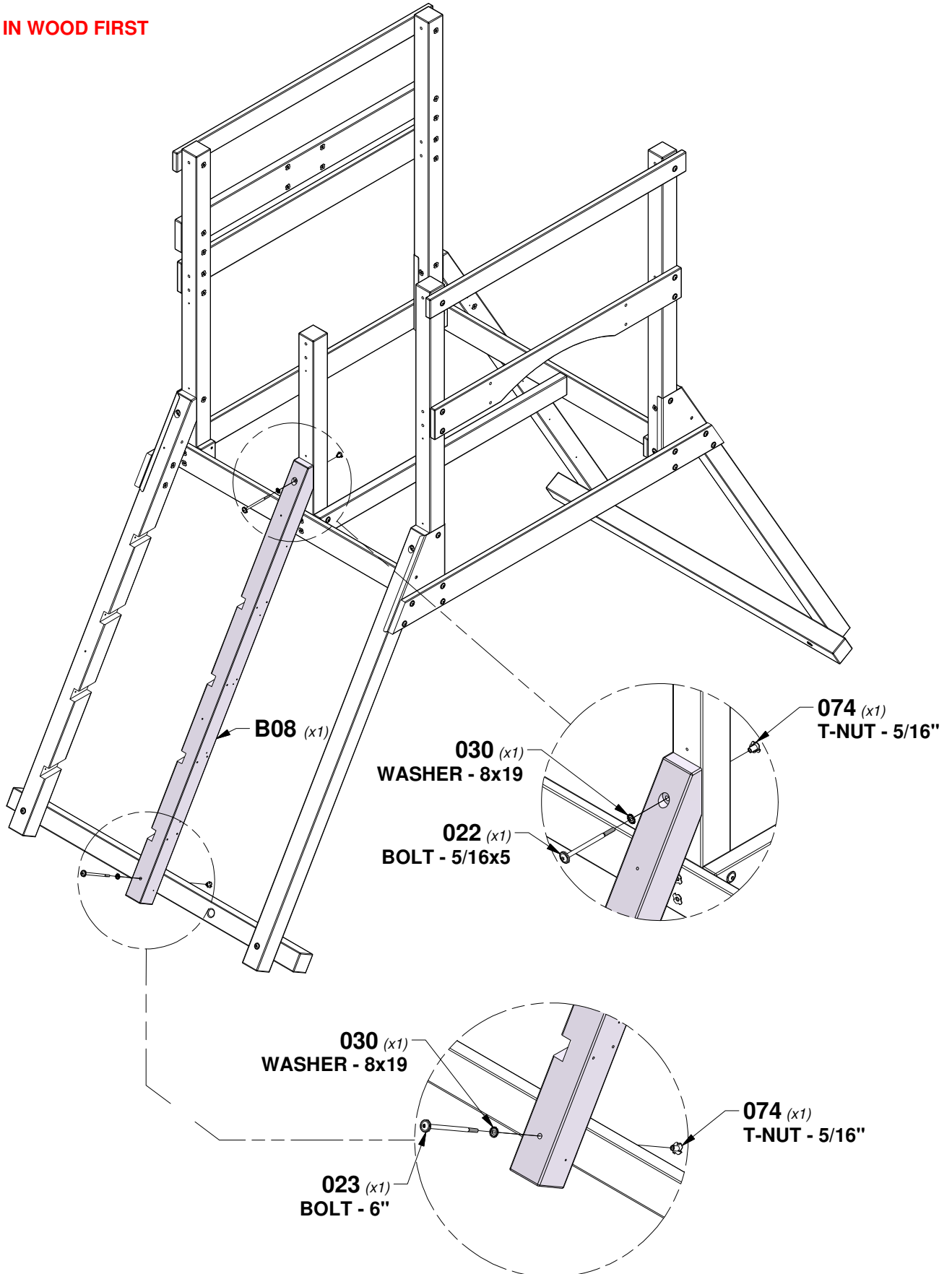

STEP 13 - FORT ASSEMBLY

QTY	PART NUMBER	DESCRIPTION
16	H100092	SCREW PFH 8x3



AL01 | STEP - W4L16431
(x4) | 1 3/8"x4 3/8"x22 3/4" (36x112x579)

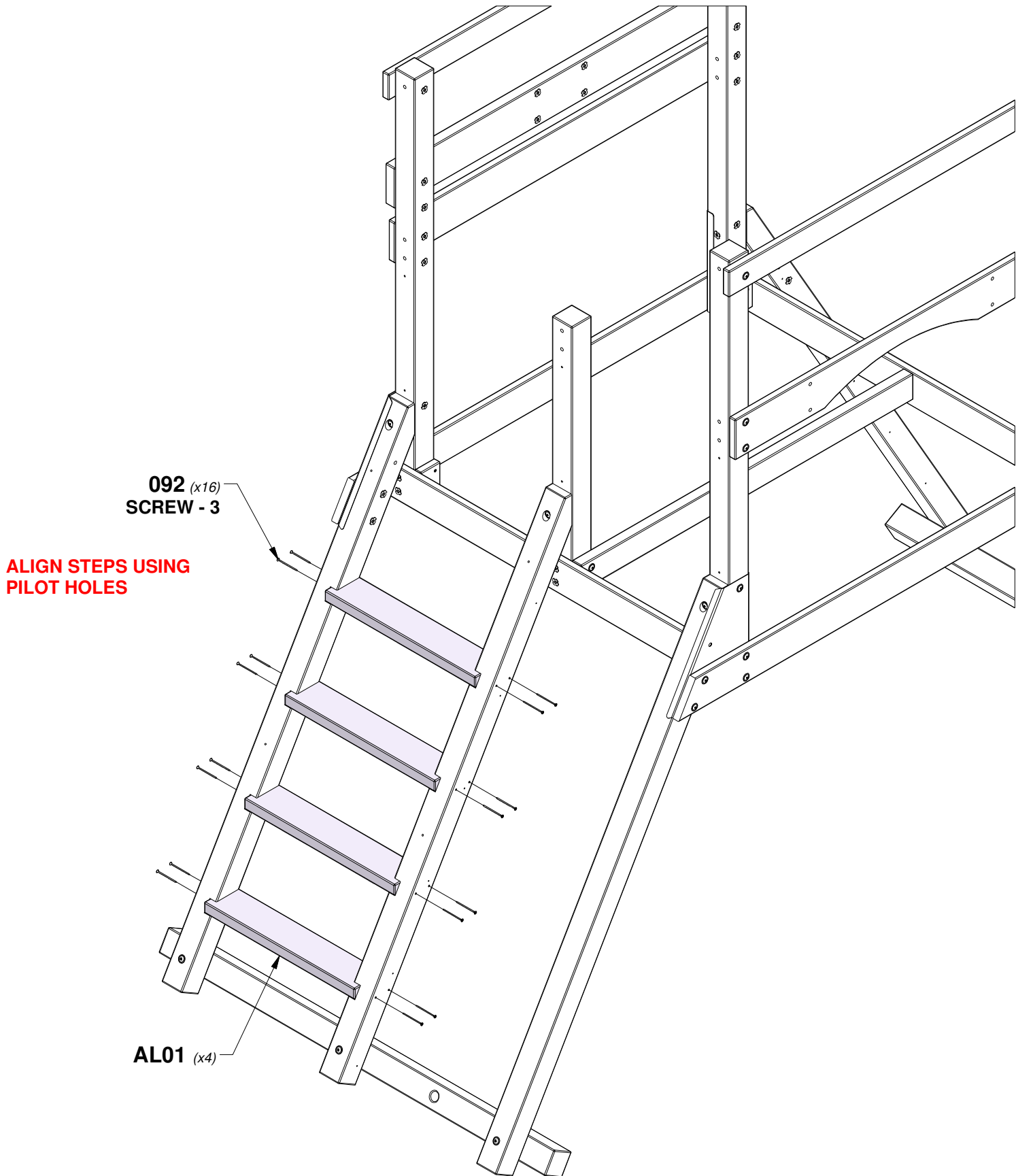

STEP 14A - FORT ASSEMBLY

QTY	PART NUMBER	DESCRIPTION
3	H100089	SCREW PFH 8x1-3/4"
12	H100092	SCREW PFH 8x3

T01 | CLEAT - W4L16442
(x1) | 1"x1 3/8"x21 1/2" (24x34x546)

F01 | CLEAT - W4L16440
(x2) | 1 3/8"x2"x59 1/2" (36x52x1510)

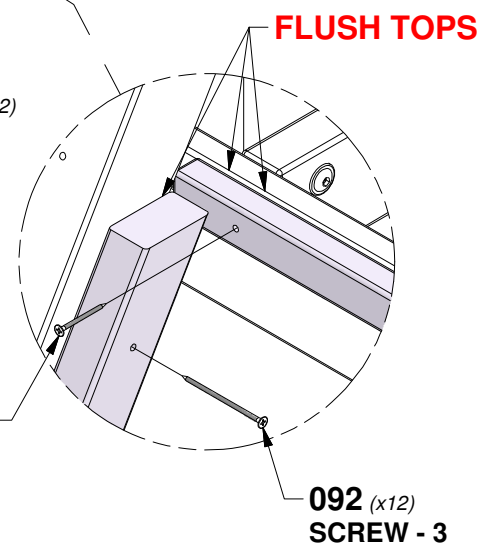
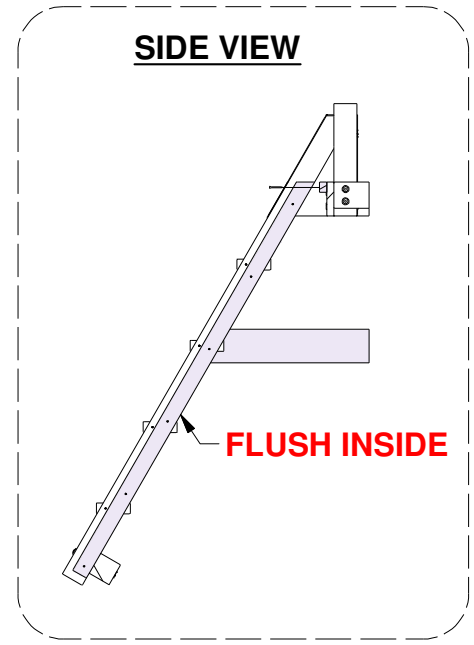
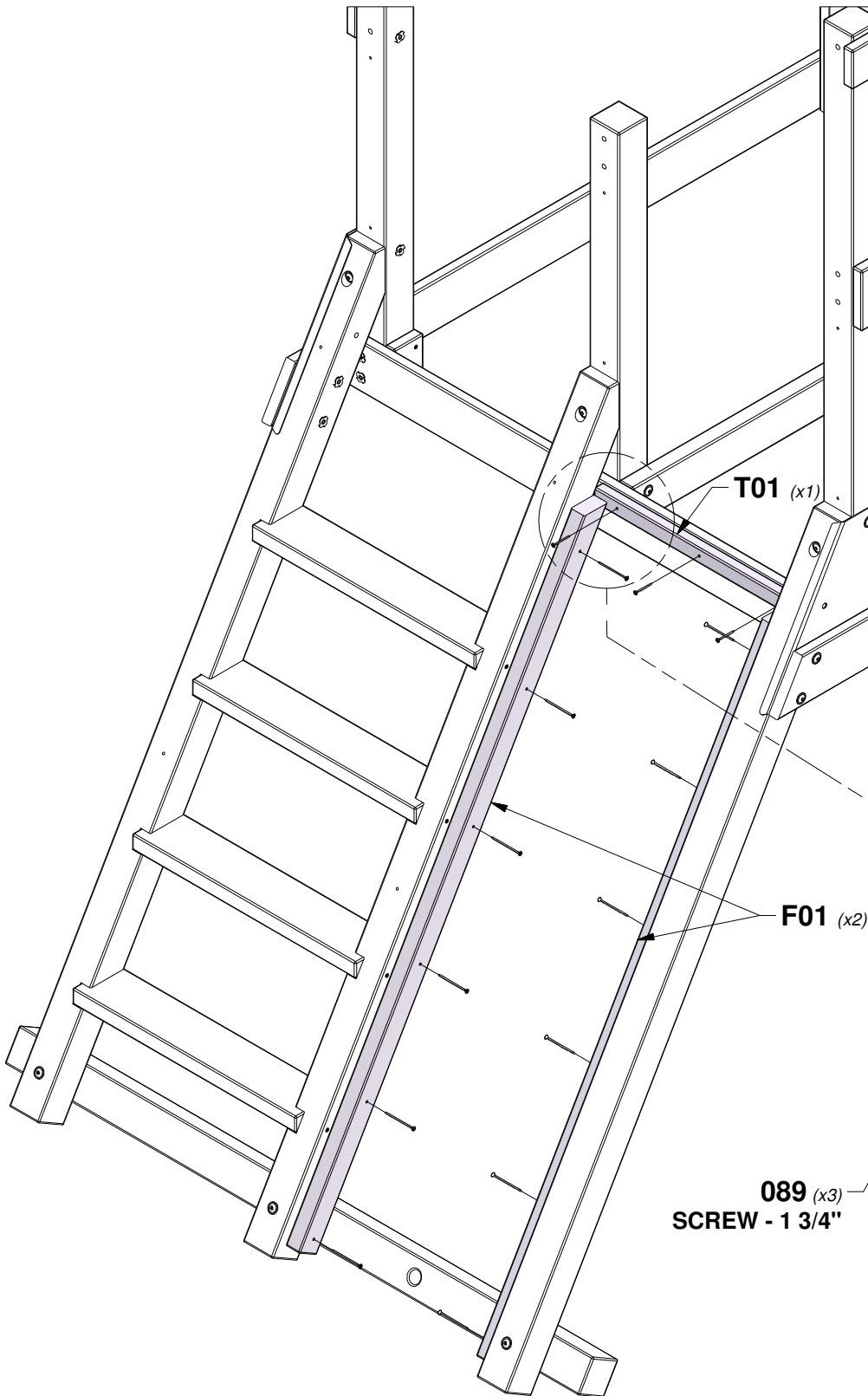

STEP 14B - FORT ASSEMBLY

QTY	PART NUMBER	DESCRIPTION
4	H100027	LAG SCREW WH 5/16x2
4	H100030	WASHER LOCK EXT 8x19



Q04 | SAFETY RAIL - W4L16475
 (x1) | 1"x4 3/8"x89 1/2" (24x112x2274)

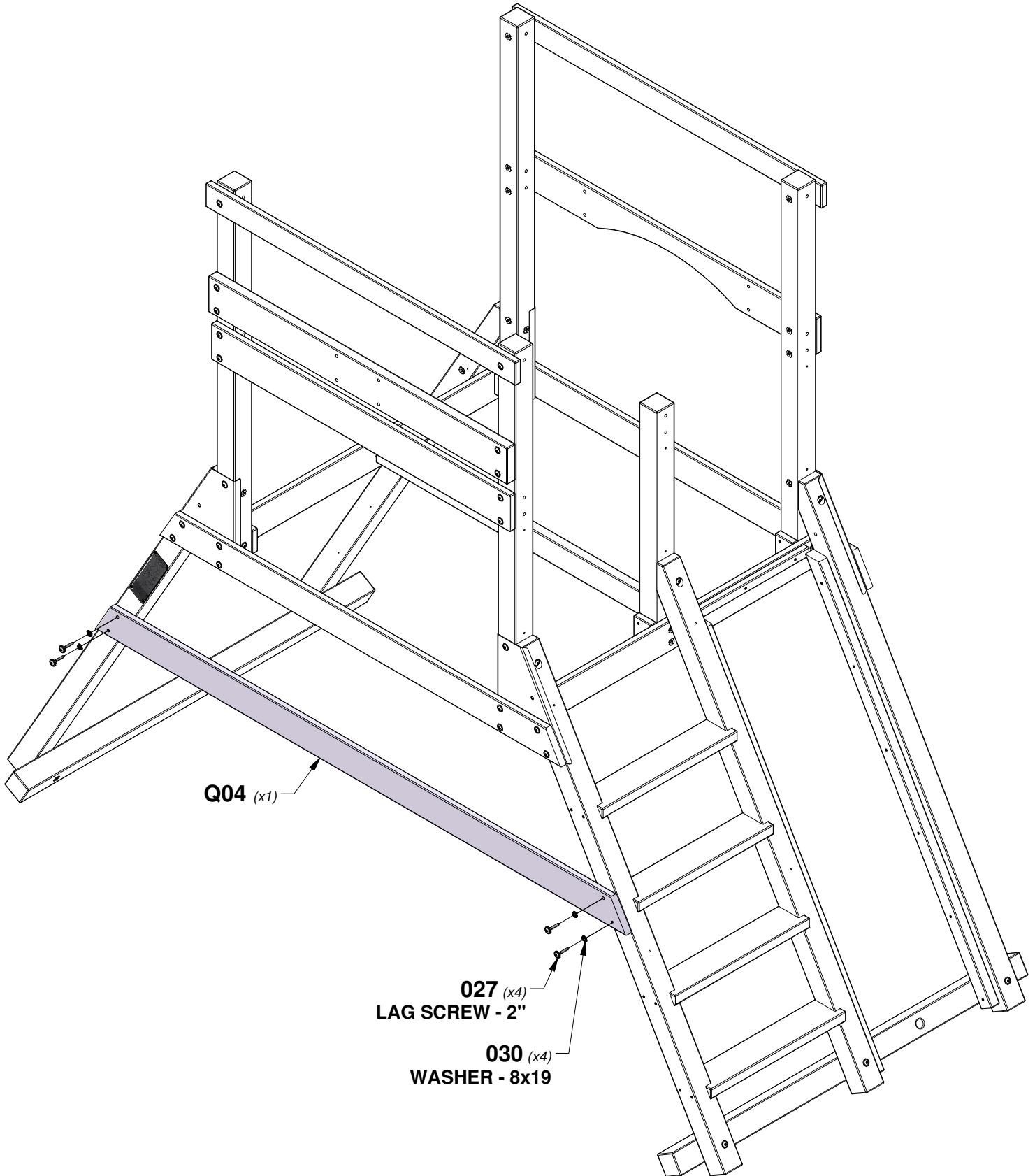

STEP 15 - FORT ASSEMBLY

QTY	PART NUMBER	DESCRIPTION
36	H100086	SCREW PFH 8x1-1/2"
32	H100111	SCREW PFH 8x2



H04 ROPE WALL BOARD - W4L16438
(x8) 1"x3 3/8"x20 7/8" (24x86x529)

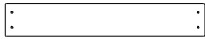

M02 ROPE WALL BOARD - W4L16436
(x8) 5/8"x3 3/8"x20 7/8" (16x86x529)

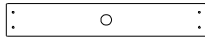

M03 ROPE WALL BOARD - W4L16451
(x1) 5/8"x3 3/8"x20 7/8" (16x86x529)

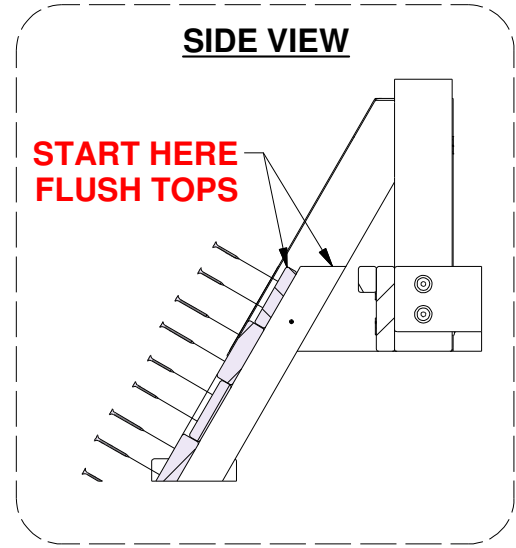
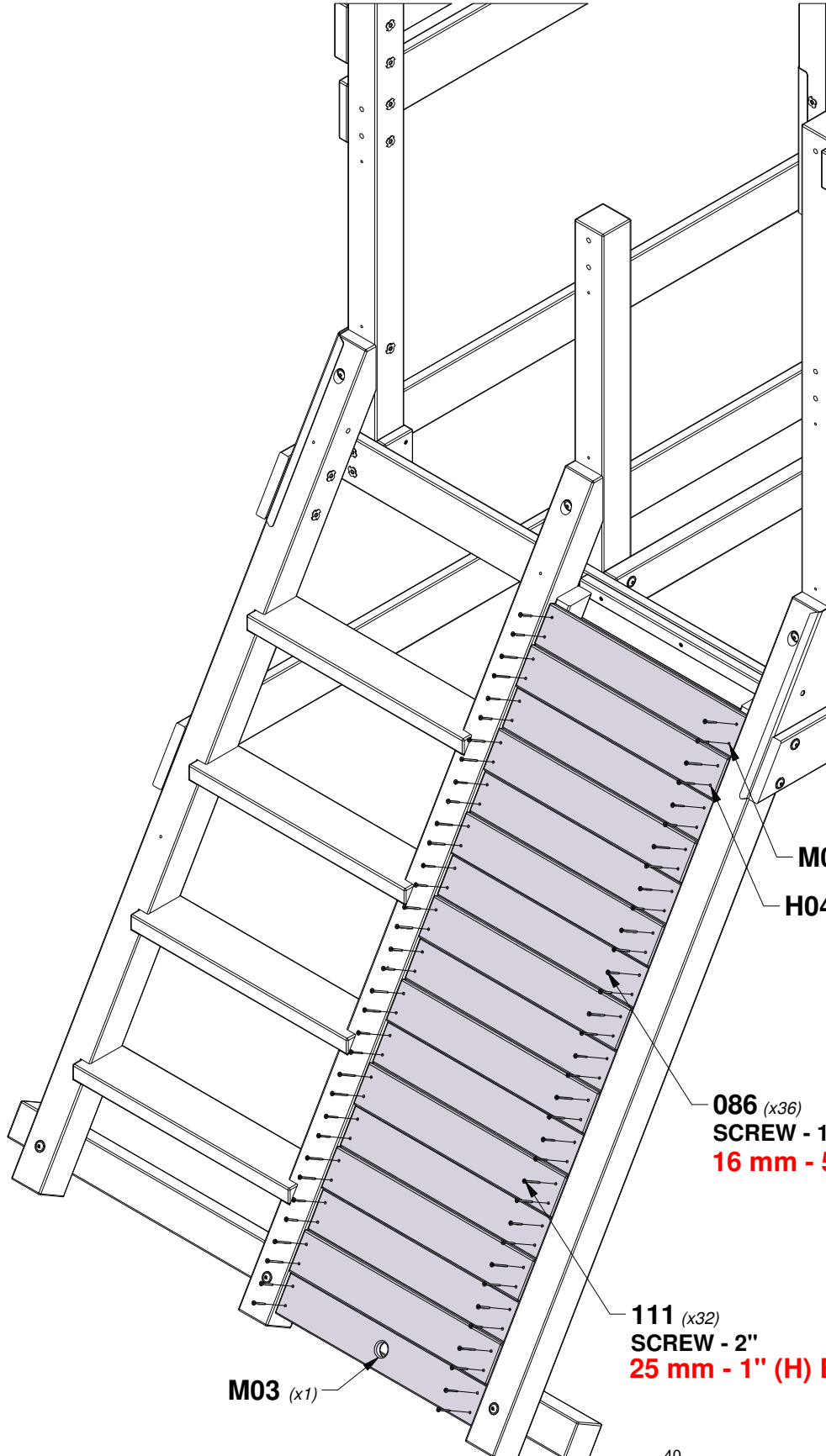

M02 (x8)
H04 (x8) **ALTERNATE (M02) & (H04) PATTERN AS YOU GO DOWN**

086 (x36)
SCREW - 1 1/2"
16 mm - 5/8" (M) BOARDS

111 (x32)
SCREW - 2"
25 mm - 1" (H) BOARDS

M03 (x1)

STEP 16 - FORT ASSEMBLY

QTY	PART NUMBER	DESCRIPTION
6	H100089	SCREW PFH 8x1-3/4"
12	H100092	SCREW PFH 8x3

T01 | CLEAT - W4L16442
(x2) | 1"x1 3/8"x21 1/2" (24x34x546)

F01 | CLEAT - W4L16440
(x2) | 1 3/8"x2"x59 1/2" (36x52x1510)

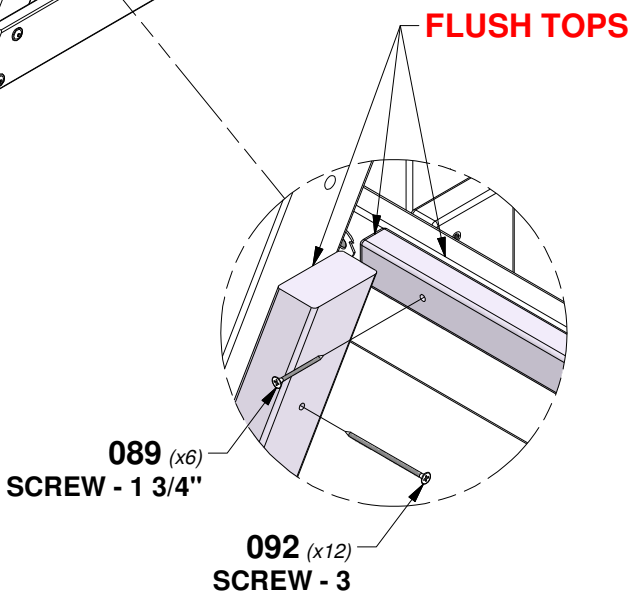
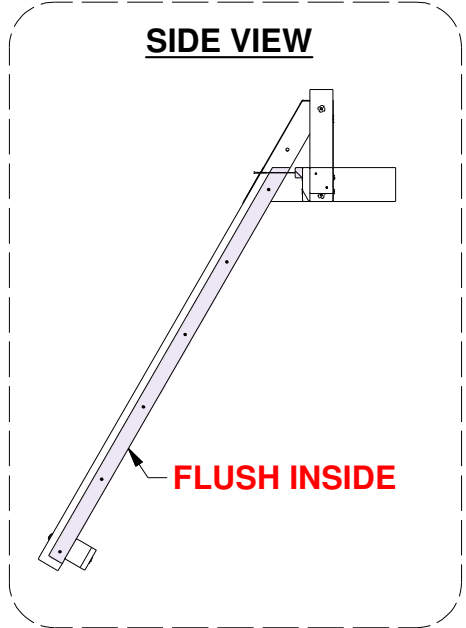
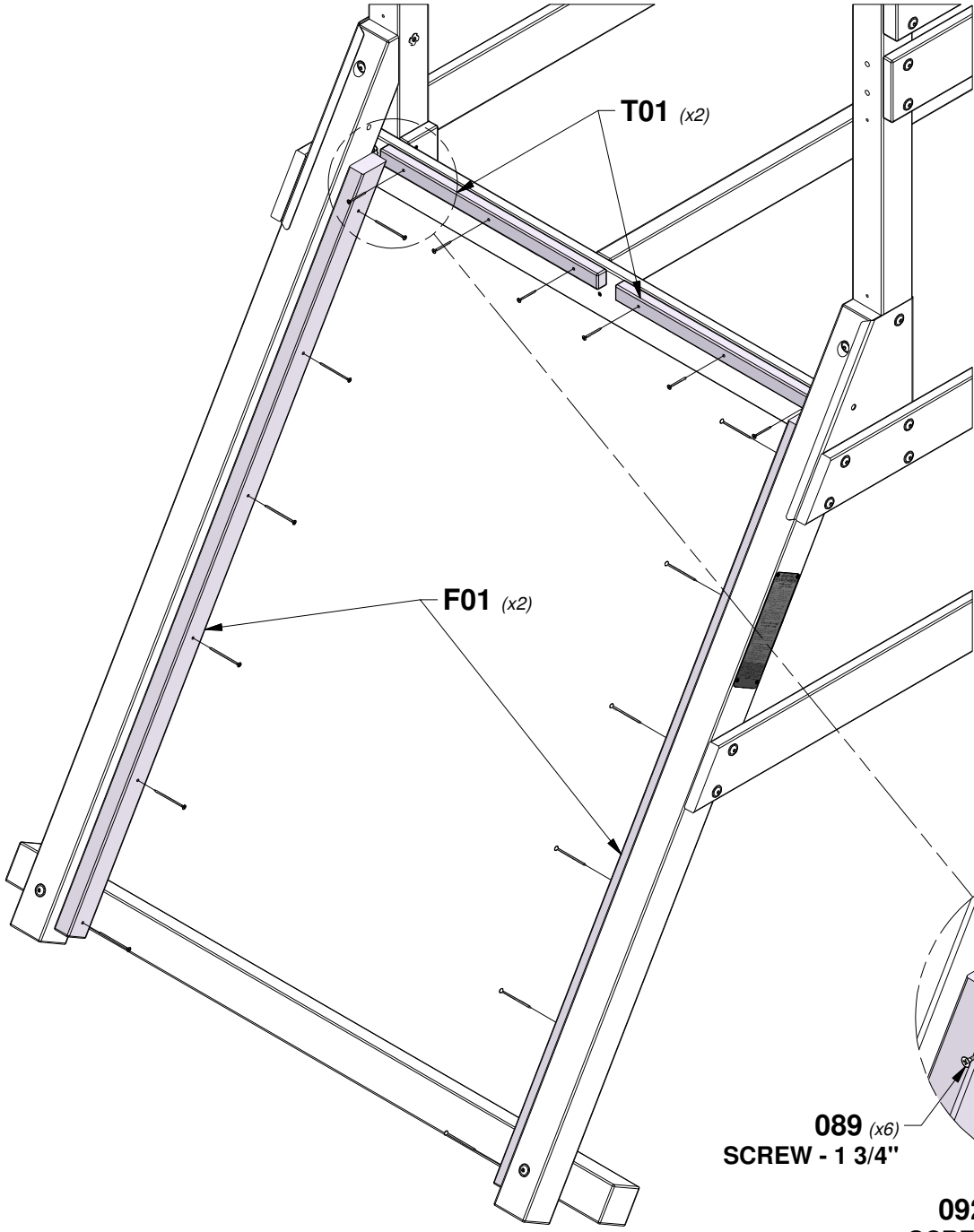

STEP 17A - FORT ASSEMBLY

QTY	PART NUMBER	DESCRIPTION
26	H100072	T-NUT 1/4
26	H100108	WASHER LOCK INT 8x15
26	H100137	BOLT WH 1/4x1



G05 | ROCK WALL BOARD - W4L16444
(x5) | 1"x5 1/4"x44 5/8" (24x134x1135)



G06 | ROCK WALL BOARD - W4L16445
(x4) | 1"x5 1/4"x44 5/8" (24x134x1135)



A6P00037 | GREEN HC ROCK
(x6) | #2



A6P00036 | GREEN HC ROCK
(x7) | #1

TIP:
INSTALL T-NUTS IN WOOD FIRST

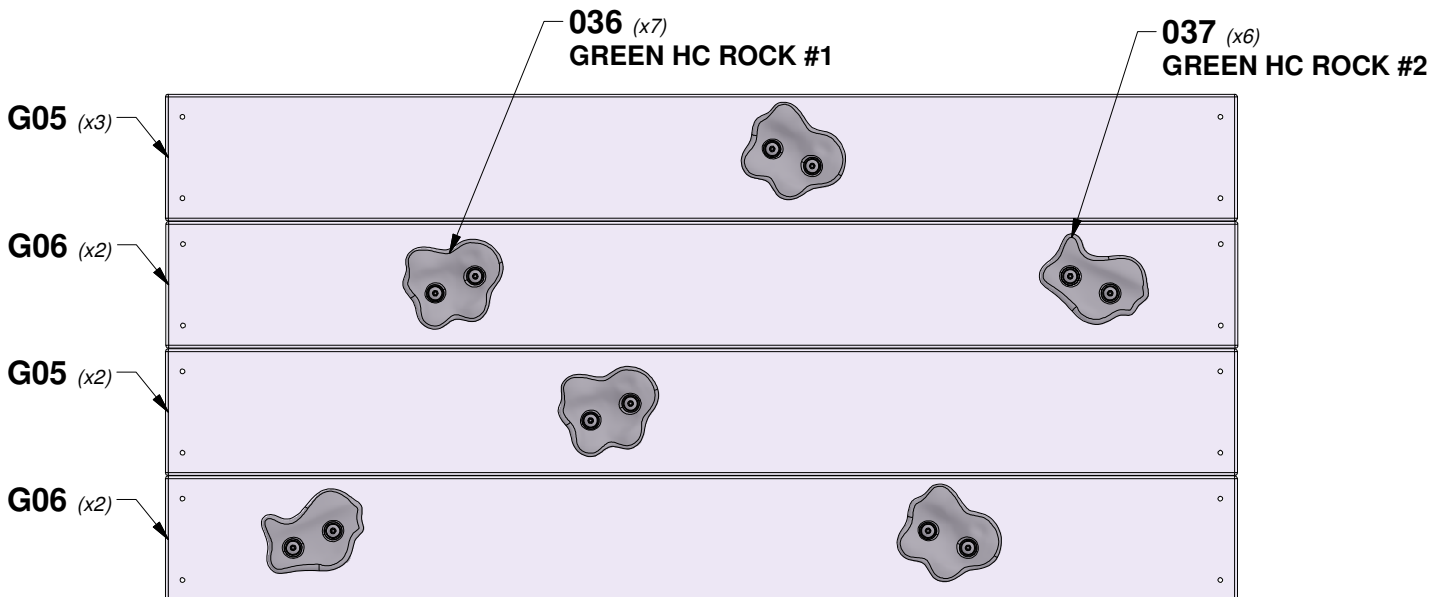
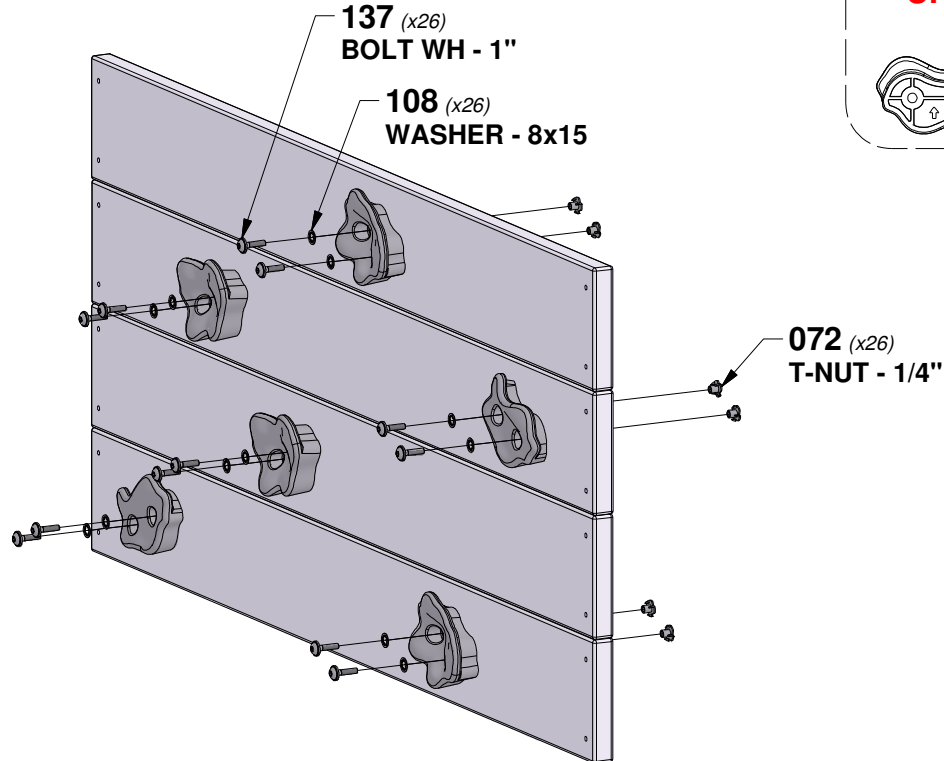
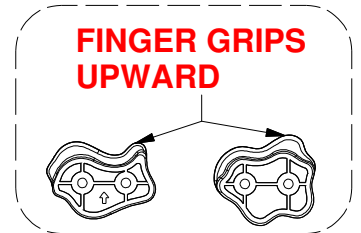

PLACE ROCKS RANDOMLY

STEP 17B - FORT ASSEMBLY

QTY	PART NUMBER	DESCRIPTION
44	H100111	SCREW PFH 8x2"



G01 | ROCK WALL BOARD - W4L16452
(x2) | 1"x5 1/4"x44 5/8" (24x134x1135)

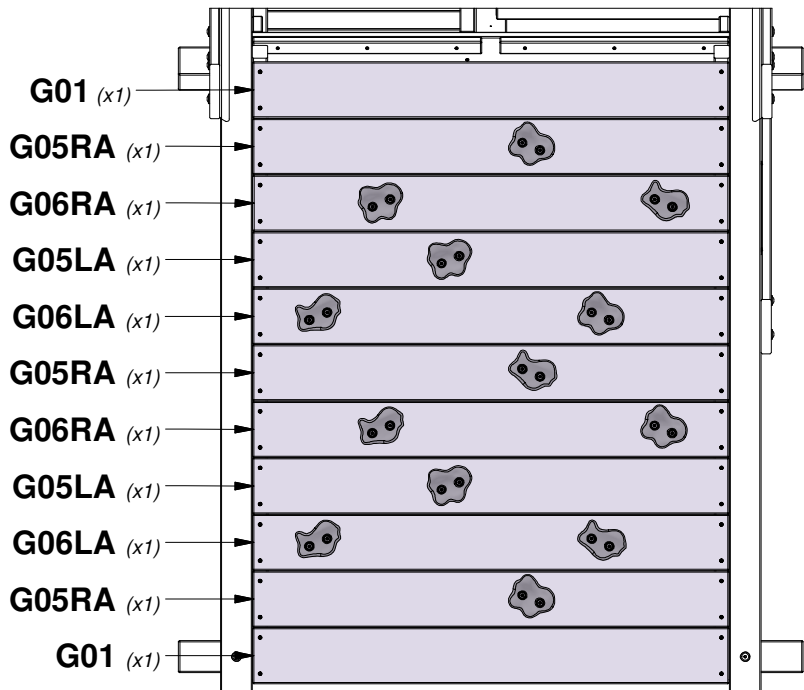
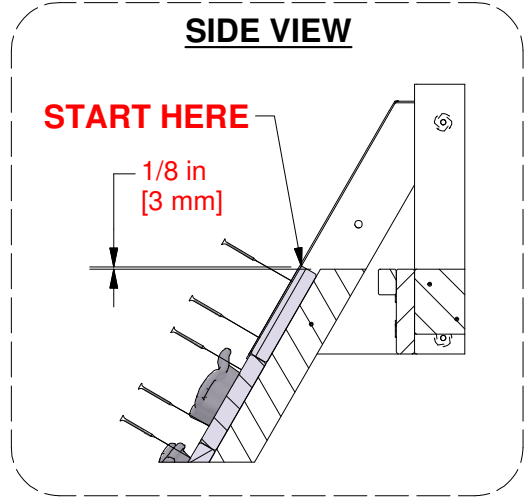
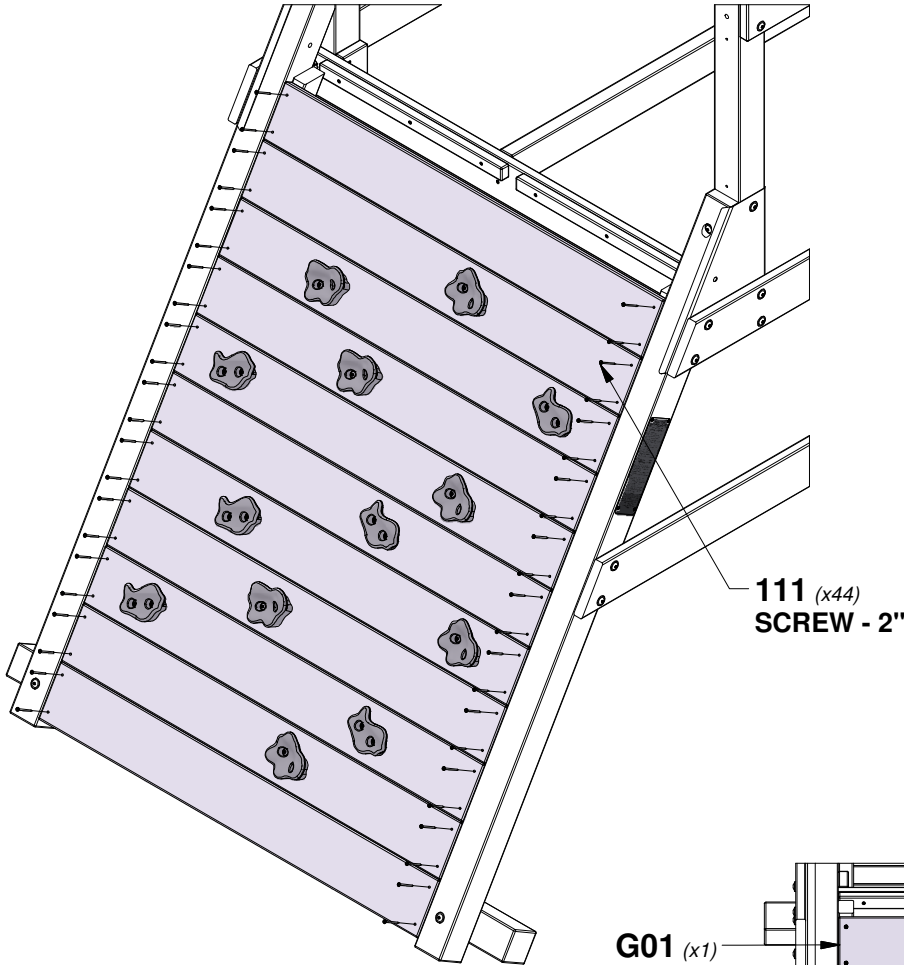
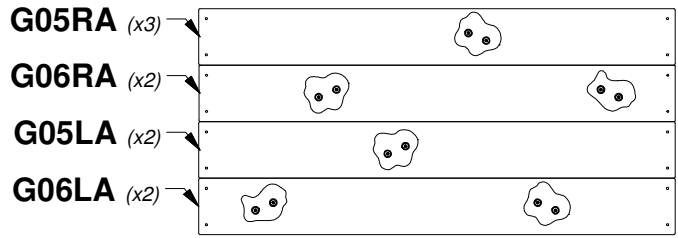

STEP 18 - FORT ASSEMBLY

QTY	PART NUMBER	DESCRIPTION
20	H100086	SCREW PFH 8x1-1/2"

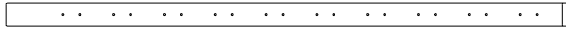

J01 | ROCK WALL CLEAT - W4L16447
 (x1) 1"x2 3/8"x58 1/2" (24x60x1486)

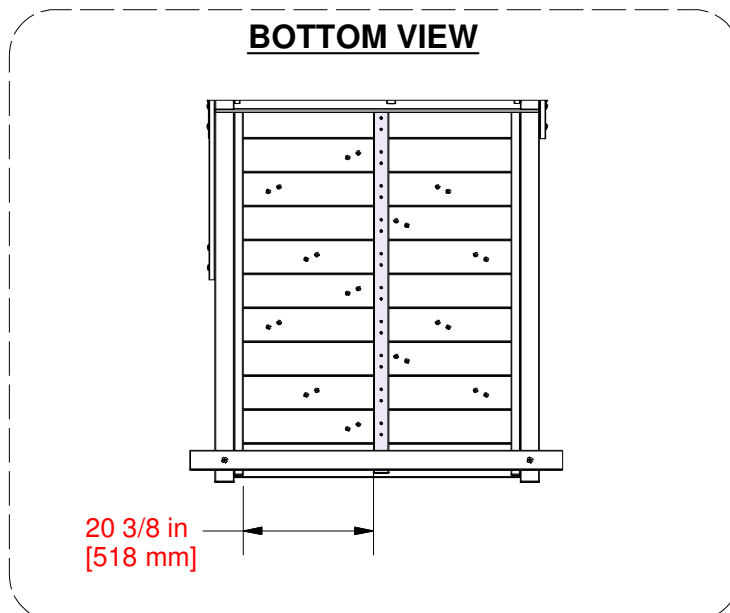
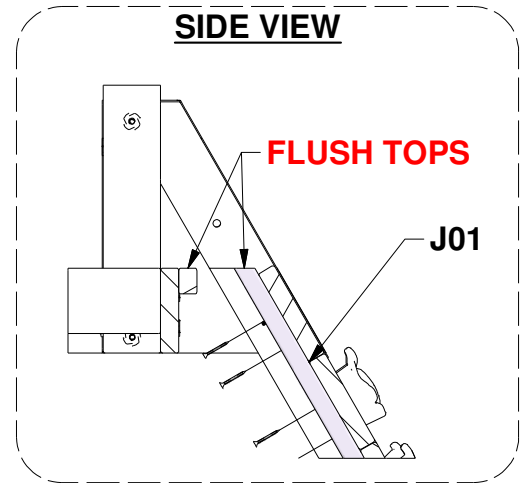
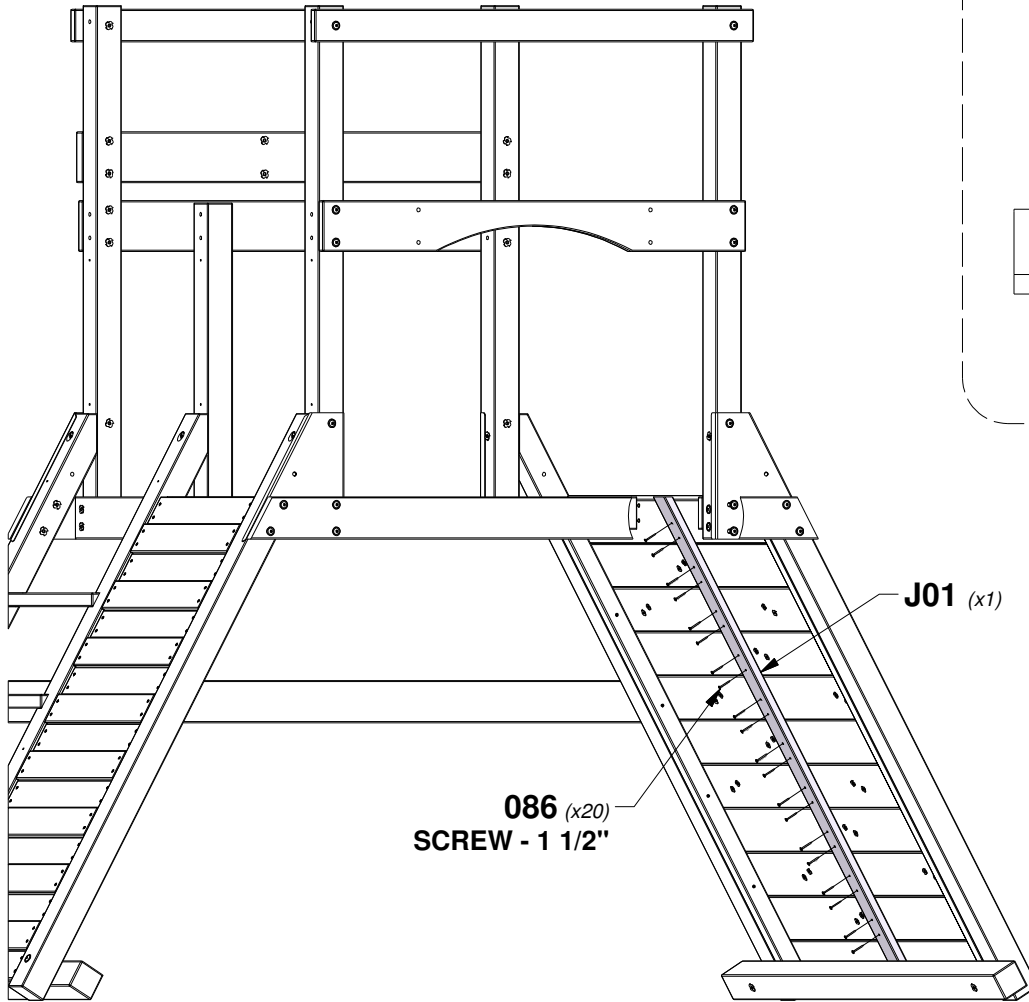

STEP 19 - FORT ASSEMBLY

QTY	PART NUMBER	DESCRIPTION
78	H100086	SCREW PFH 8x1-1/2"

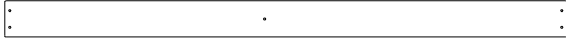

M01 | FLOOR BOARD - W4L16437
(x13) | 5/8"x3 3/8"x52 3/4" (16x86x1339)



Y01 | FLOOR BOARD - W4L16432
(x2) | 5/8"x4"x20 7/8" (16x102x529)



Y02 | FLOOR BOARD - W4L16439
(x1) | 5/8"x4"x44 5/8" (16x102x1135)

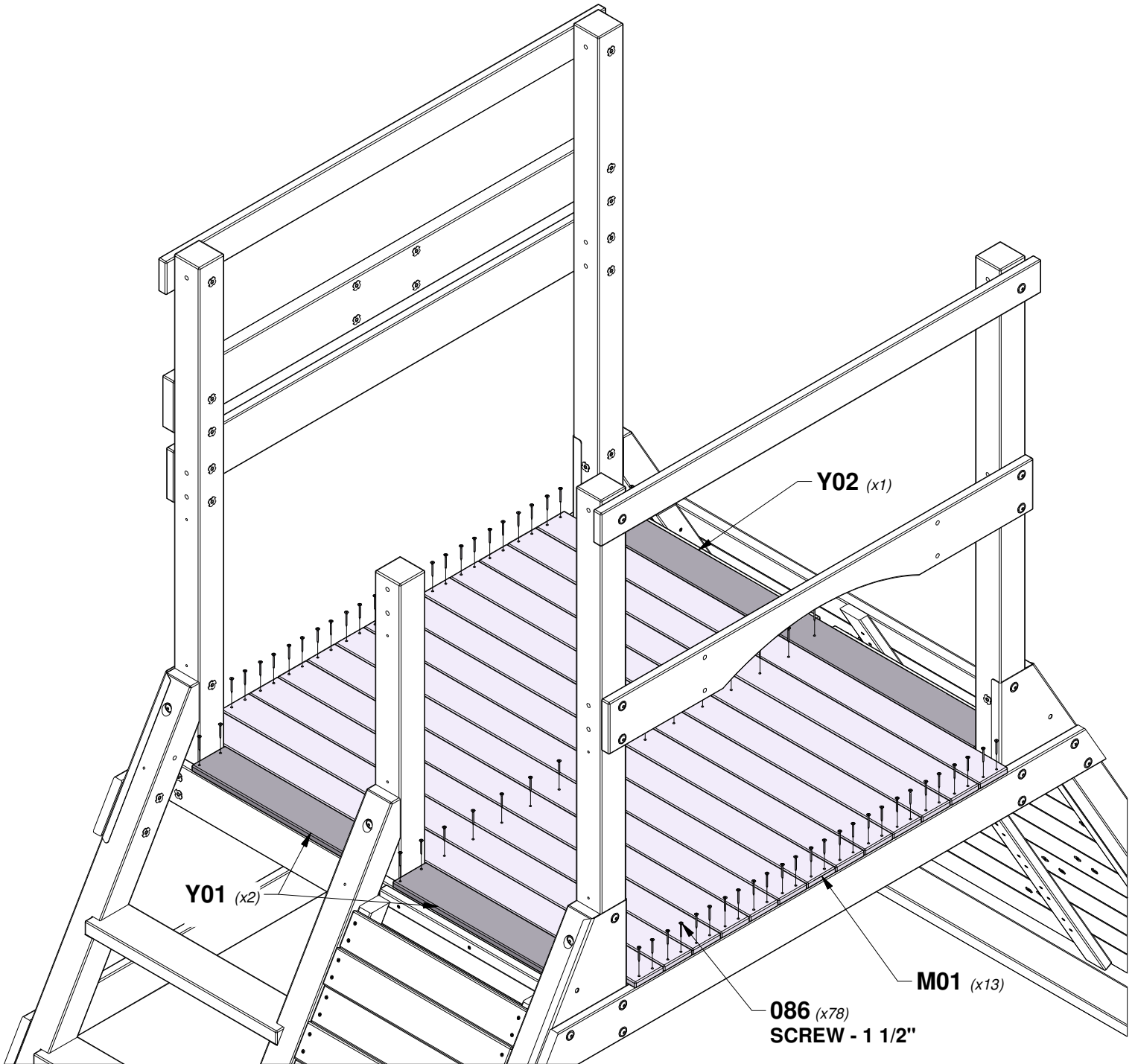

STEP 20 - FORT ASSEMBLY

QTY	PART NUMBER	DESCRIPTION
11	H100086	SCREW PFH 8x1-1/2"



K04 | FLOOR BOARD - W4L16448
 (x1) | 5/8"x4 3/4"x44 5/8" (16x120x1135)

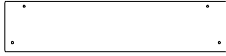

K05 | FLOOR BOARD - W4L16449
 (x1) | 5/8"x4 3/4"x20 7/8" (16x120x529)

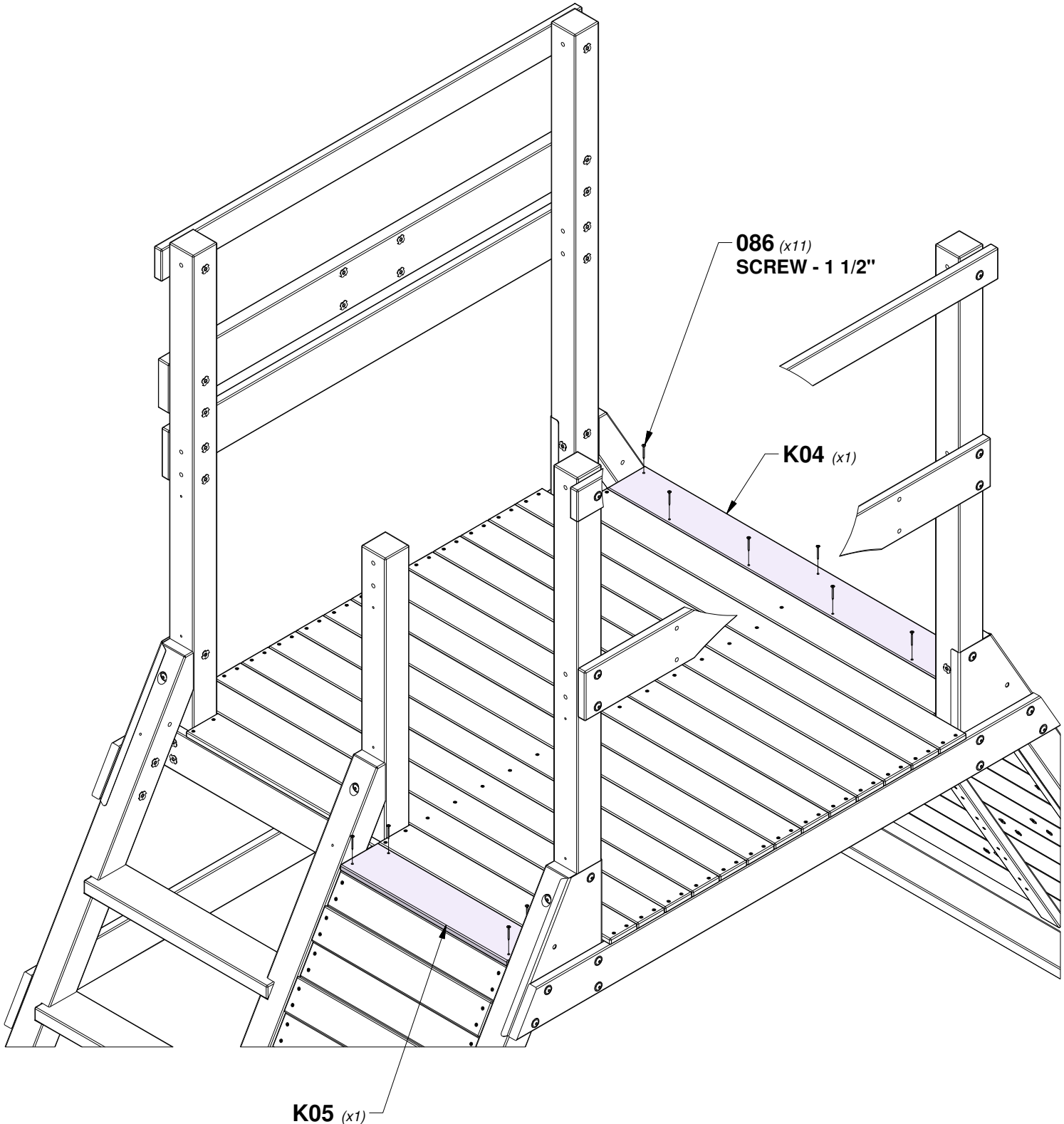

086 (x11)
 SCREW - 1 1/2"

K04 (x1)

K05 (x1)

STEP 21 - FORT ASSEMBLY

QTY	PART NUMBER	DESCRIPTION
4	H100019	BOLT WH 5/16x3 3/4
4	H100030	WASHER LOCK EXT 8x19
4	H100074	T-NUT 5/16



H01 | FLOOR RAIL - W4L16428
(x1) | 1"x3 3/8"x61 3/4" (24x86x1569)



H02 | FLOOR RAIL - W4L16429
(x2) | 1"x3 3/8"x18 3/4" (24x86x477)

TIP:
INSTALL T-NUTS IN WOOD FIRST

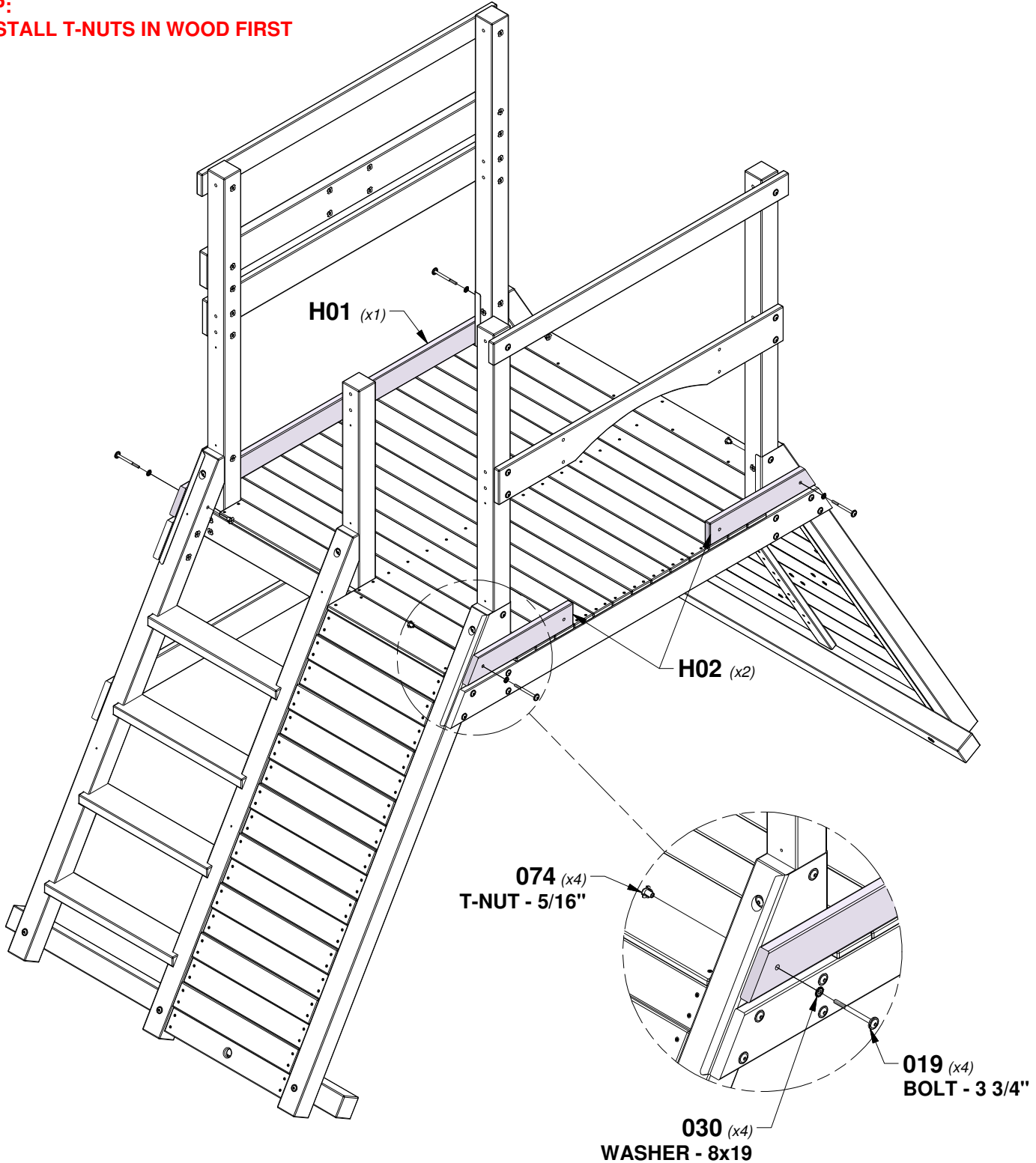

STEP 22 - FORT ASSEMBLY



H05 | WALL RAIL - W4L16450
(x2) | 1"x3 3/8"x29 7/8" (24x86x760)



A4M01047 | L BRACKET
(x2) | 2.5x38x55x55

QTY	PART NUMBER	DESCRIPTION
2	H100005	NUT BARREL WH 5/16x7/8
4	H100011	BOLT WH 5/16x1 3/4
4	H100030	WASHER LOCK EXT 8x19
2	H100031	WASHER LOCK EXT 12x19
4	H100074	T-NUT 5/16
2	H100379	T-NUT 5/16 BLK
2	H100396	BOLT WH 5/16x1/2 BLK
2	H100407	BOLT WH 5/16x1 1/2 BLK

TIP:
INSTALL T-NUTS IN WOOD FIRST

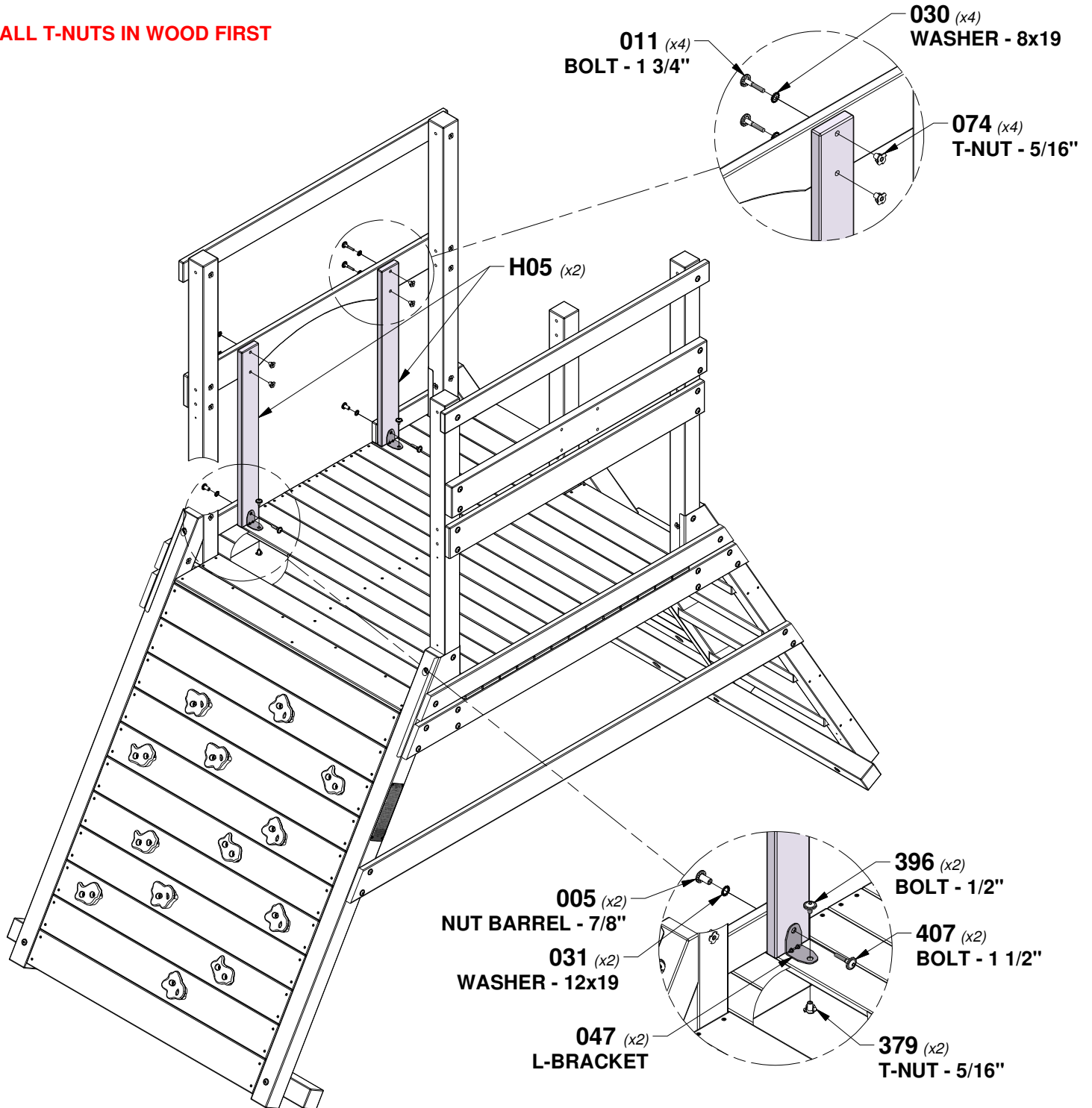

USING BRACKETS AS A GUIDE, DRILL (2) 3/8" (10mm) HOLES THRU FLOOR FOR HARDWARE.

STEP 23 - FORT ASSEMBLY

QTY	PART NUMBER	DESCRIPTION
4	H100019	BOLT WH 5/16x3 3/4
4	H100030	WASHER LOCK EXT 8x19
4	H100074	T-NUT 5/16

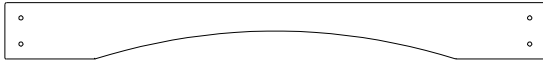

G03 | WALL RAIL - W4L16424
(x1) 1"x5 1/4"x50 3/4" (24x134x1288)

TIP:
INSTALL T-NUTS IN WOOD FIRST

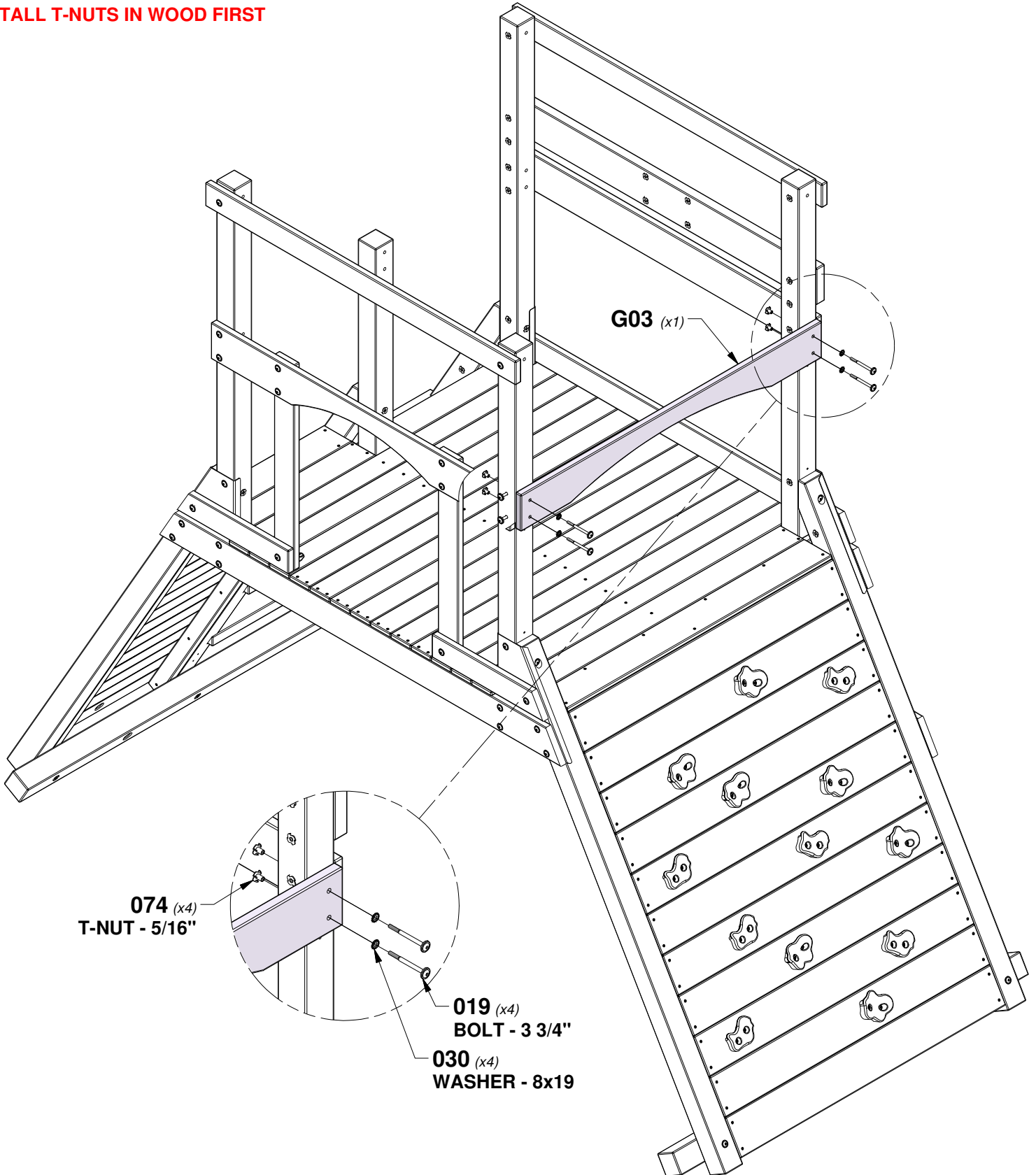

074 (x4)
T-NUT - 5/16"

019 (x4)
BOLT - 3 3/4"

030 (x4)
WASHER - 8x19

STEP 24 - FORT ASSEMBLY

QTY	PART NUMBER	DESCRIPTION
6	H100030	WASHER LOCK EXT 8x19
6	H100074	T-NUT 5/16
6	H100166	BOLT WH 5/16x4 1/4

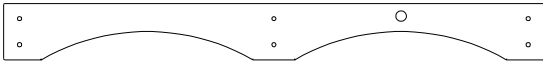

D02 | WALL RAIL - W4L16422
(x1) | 1 3/8"x5 1/4"x50 3/4" (36x134x1288)

TIP:
INSTALL T-NUTS IN WOOD FIRST

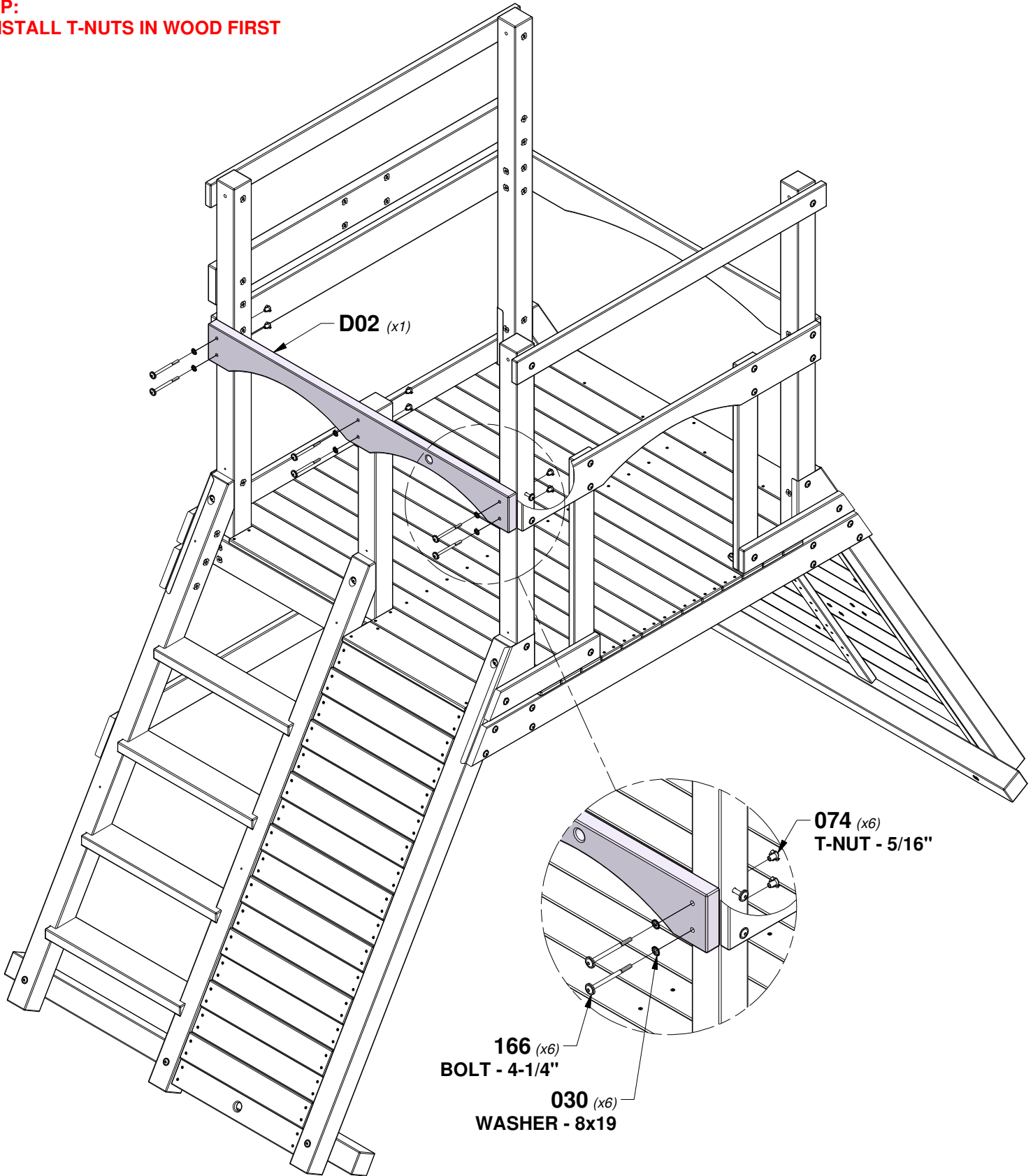

STEP 25 - FORT ASSEMBLY

QTY	PART NUMBER	DESCRIPTION
4	H100086	SCREW PFH 8x1-1/2"



M05 | SAFETY BOARD - W4L16467
 (x1) | 5/8"x3 3/8"x26 7/8" (16x86x682)

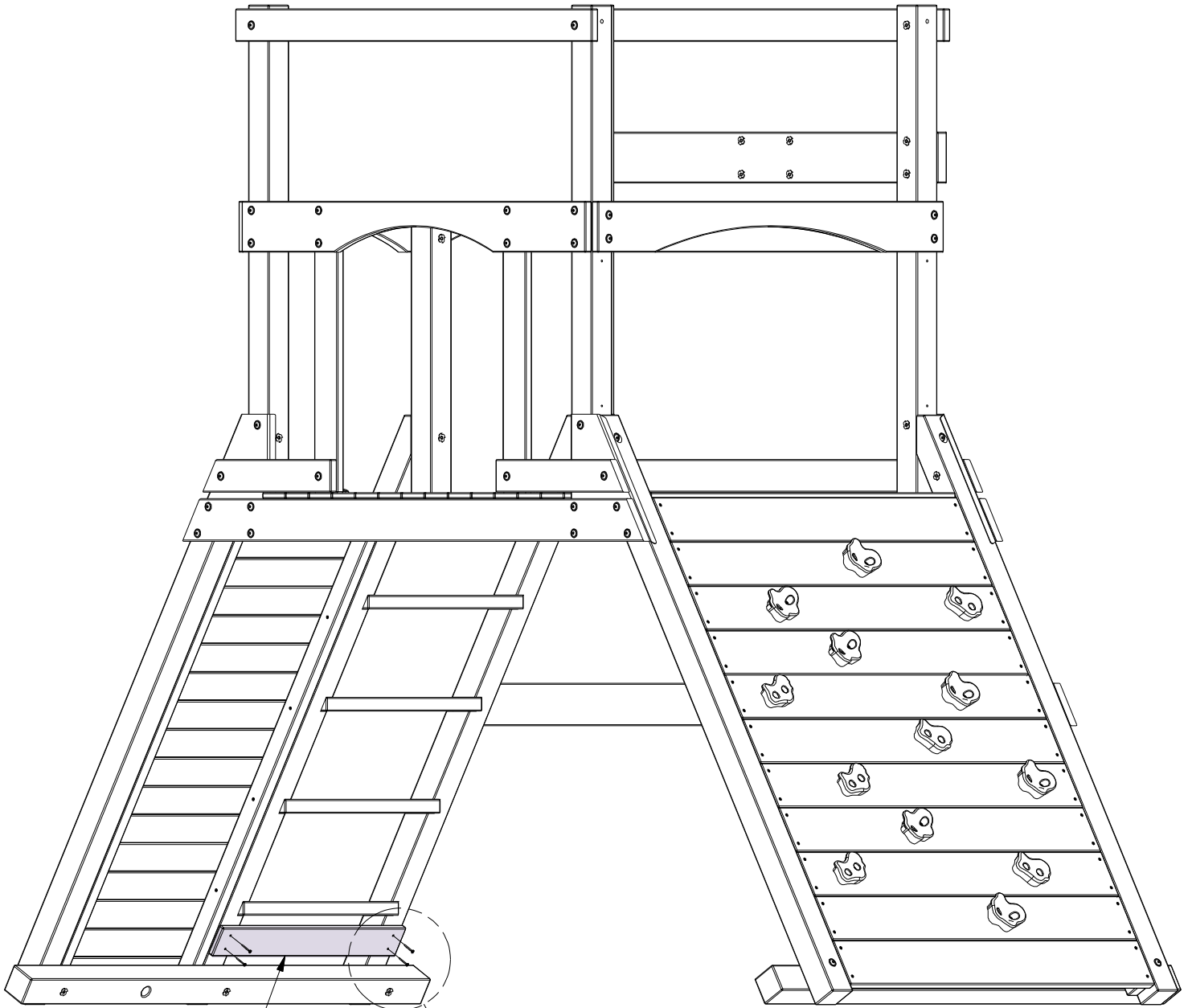

M05 (x1)

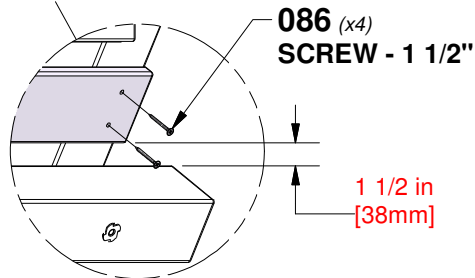

STEP 26 - FORT ASSEMBLY

QTY	PART NUMBER	DESCRIPTION
8	H100086	SCREW PFH 8x1-1/2"



M04 PICKET - W4L16466
(x2) 5/8"x3 3/8"x29 7/8" (16x86x760)

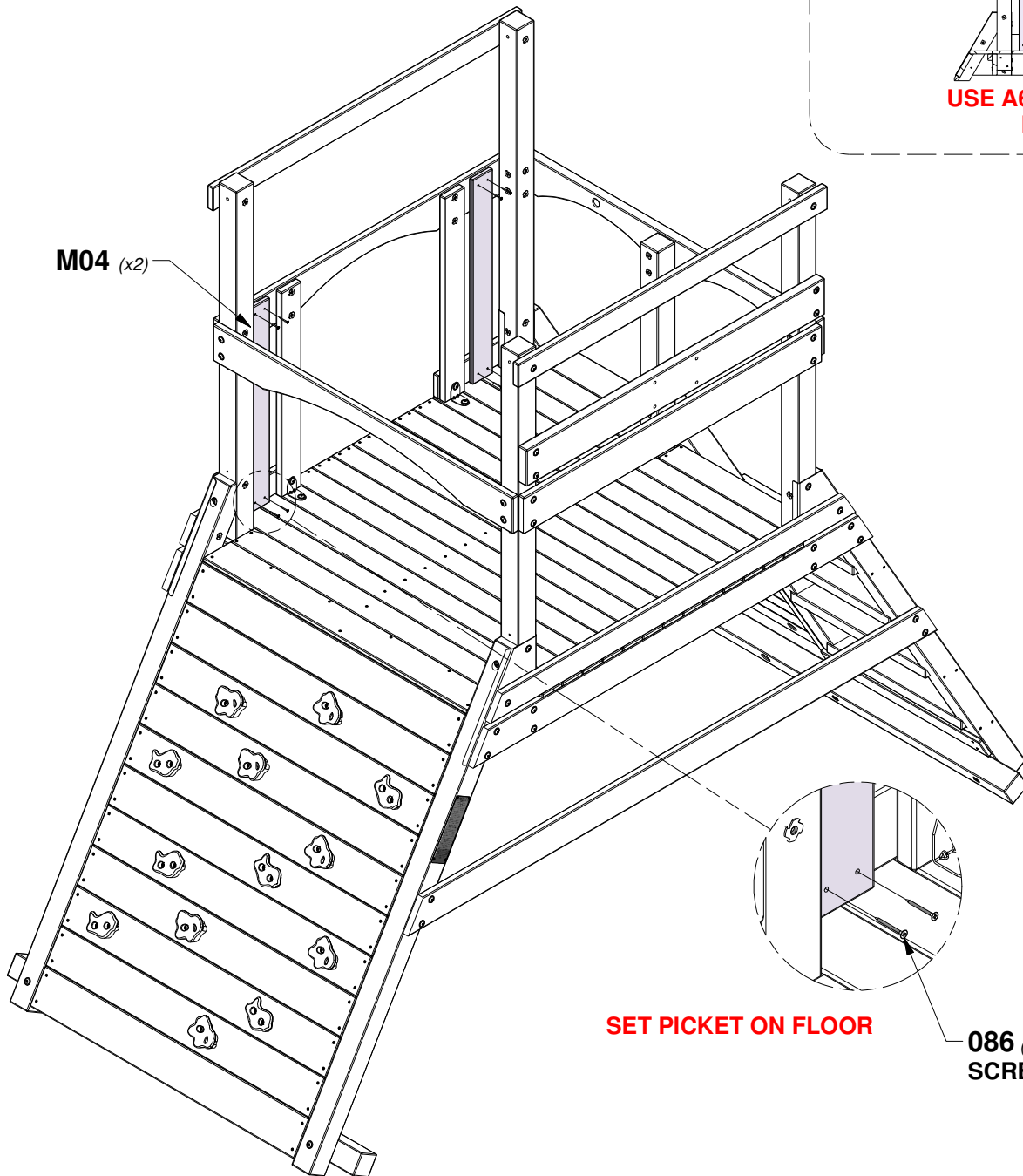
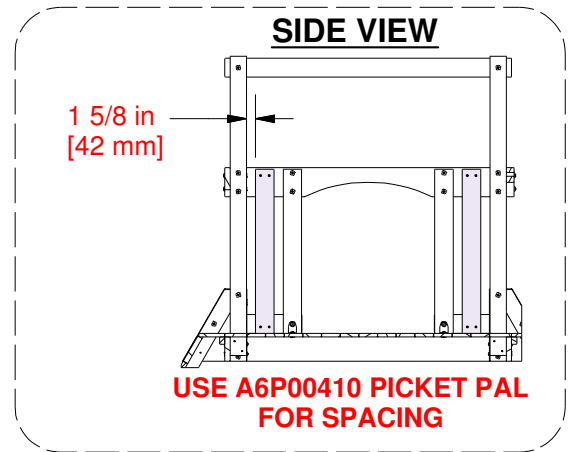

STEP 27 - FORT ASSEMBLY

QTY	PART NUMBER	DESCRIPTION
28	H100086	SCREW PFH 8x1-1/2"



M04 PICKET - W4L16466
(x7) 5/8"x3 3/8"x29 7/8" (16x86x760)

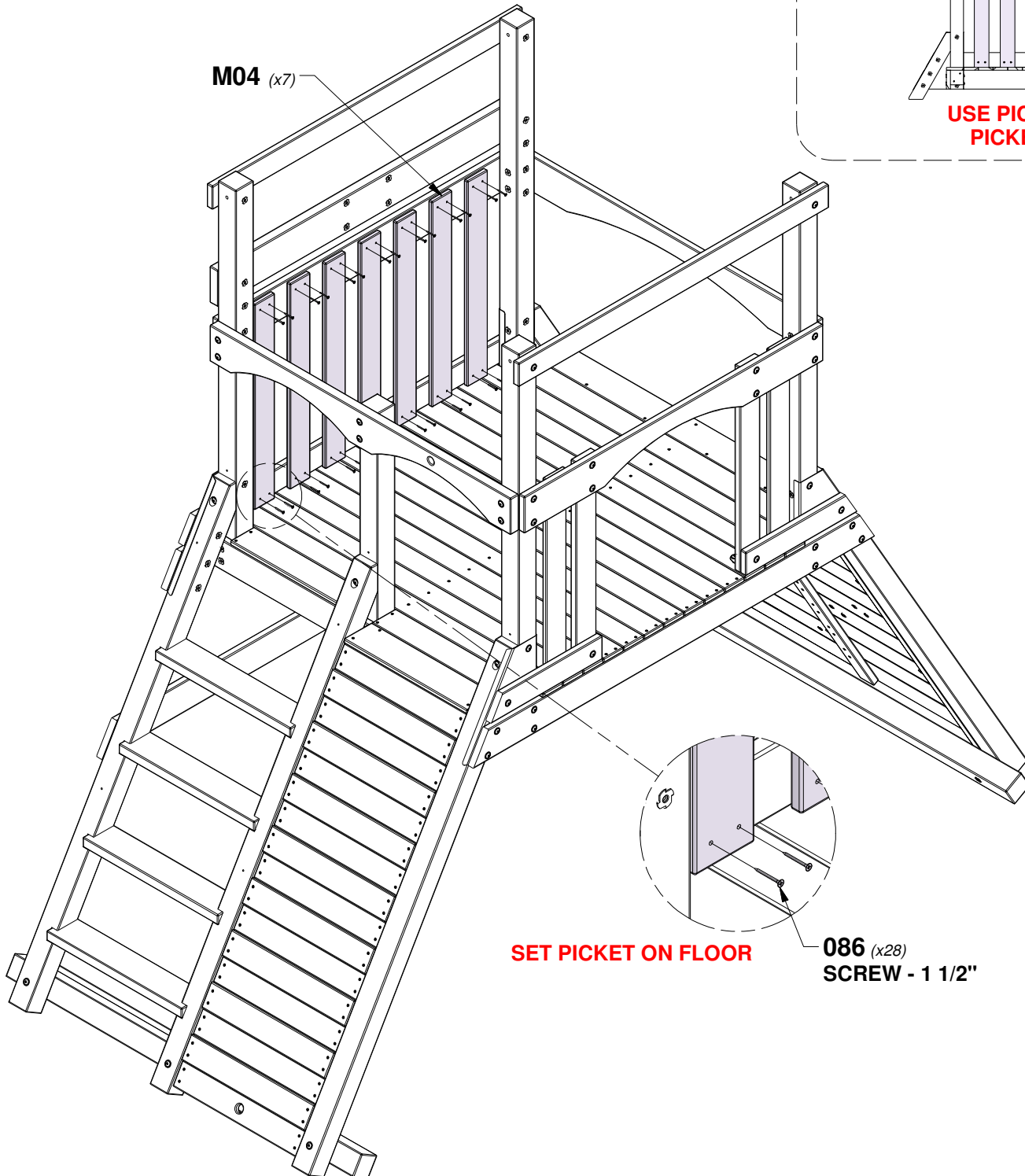
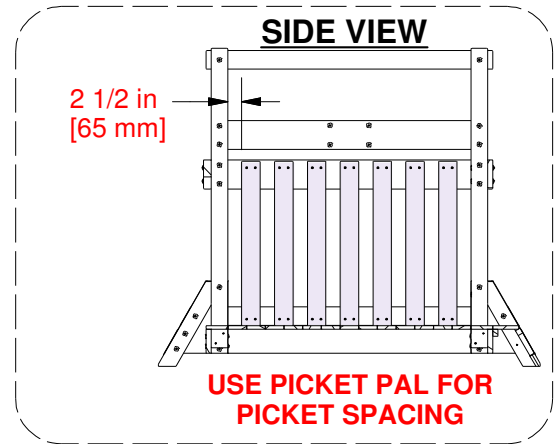

STEP 28 - FORT ASSEMBLY

QTY	PART NUMBER	DESCRIPTION
4	H100030	WASHER LOCK EXT 8x19
4	H100074	T-NUT 5/16
4	H100505	BOLT WH 5/16x4 3/4

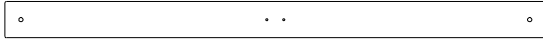

H07 | WALL RAIL - W4L16453
(x2) | 1"x3 3/8"x50 3/4" (24x86x1288)



H09 | ROOF RAIL - W4L16455
(x4) | 1"x3 3/8"x34 1/2" (24x86x877)

TIP:
INSTALL T-NUTS IN WOOD FIRST

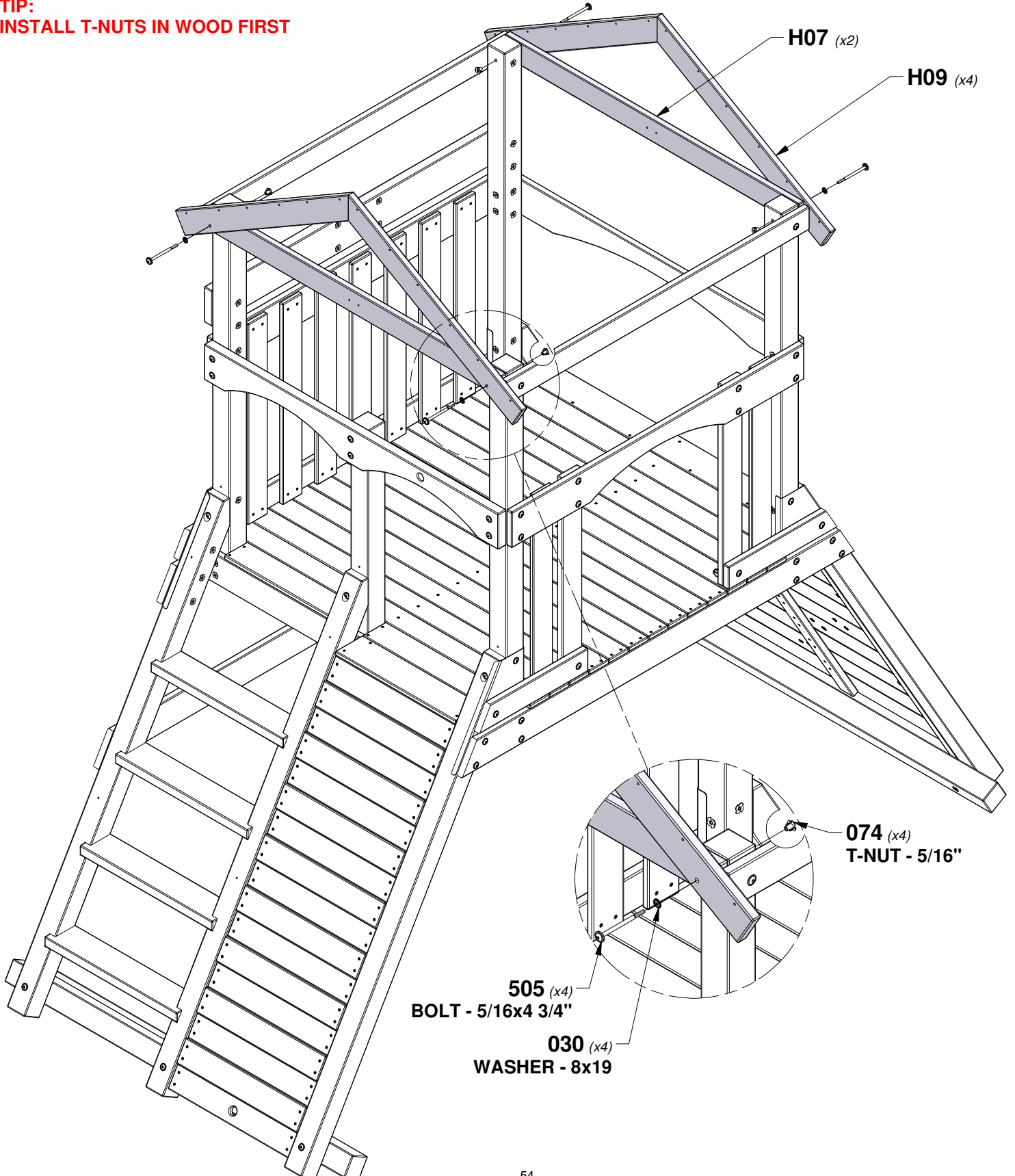

H07 (x2)

H09 (x4)

074 (x4)
T-NUT - 5/16"

505 (x4)
BOLT - 5/16x4 3/4"

030 (x4)
WASHER - 8x19

STEP 29 - FORT ASSEMBLY

QTY	PART NUMBER	DESCRIPTION
12	H100089	SCREW PFH 8x1-3/4"



H10 | GABLE BOARD - W4L16456
(x2) | 1"x3 3/8"x15 3/4" (24x86x400)



H11 | GABLE CLEAT - W4L16457
(x2) | 1"x3"x3 3/8" (24x76x86)

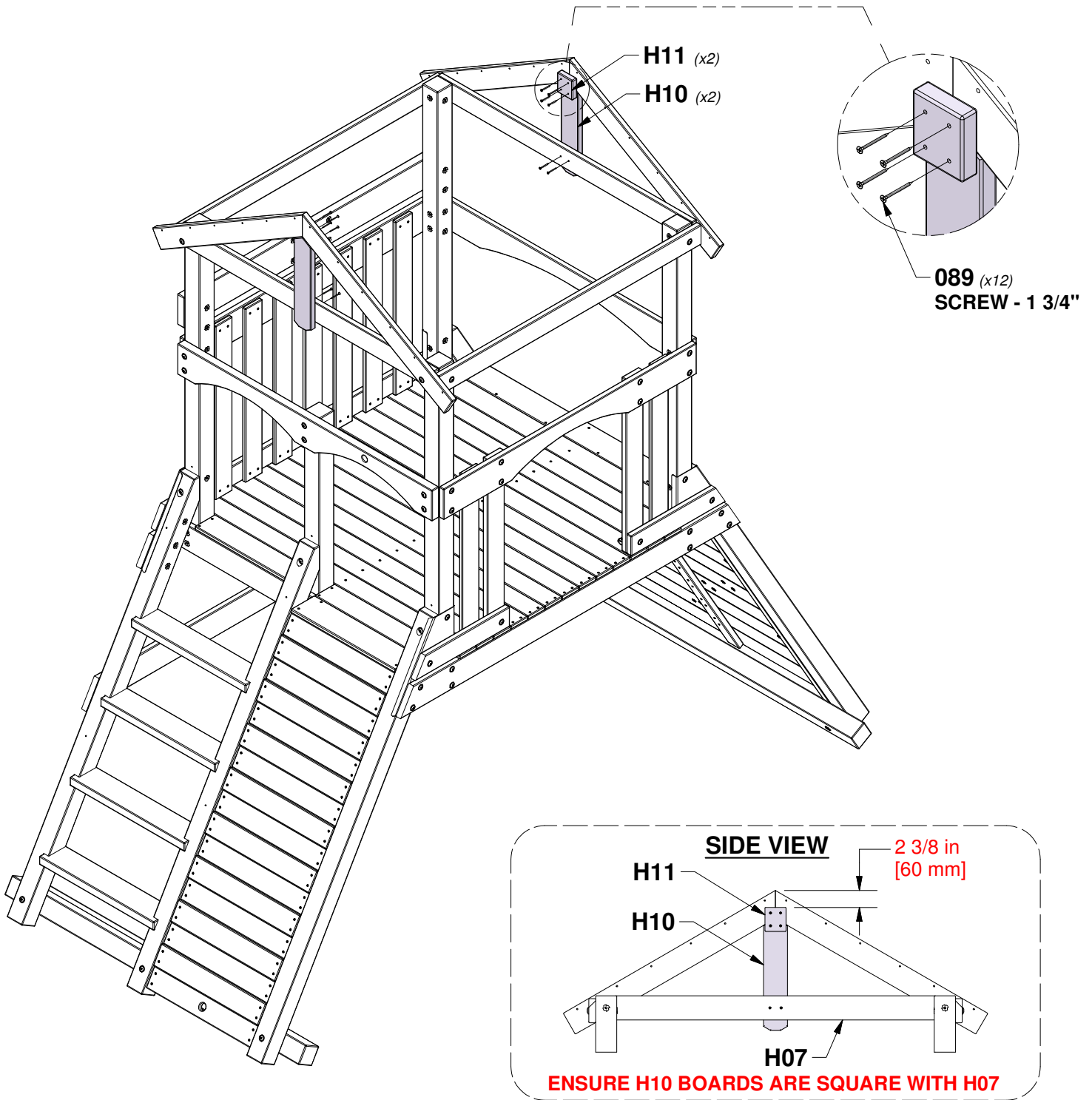

STEP 30 - FORT ASSEMBLY

QTY	PART NUMBER	DESCRIPTION
12	H100089	SCREW PFH 8x1-3/4"



H12 GABLE BOARD - W4L16458
(x4) 1"x3 3/8"x14 5/8" (24x86x370)

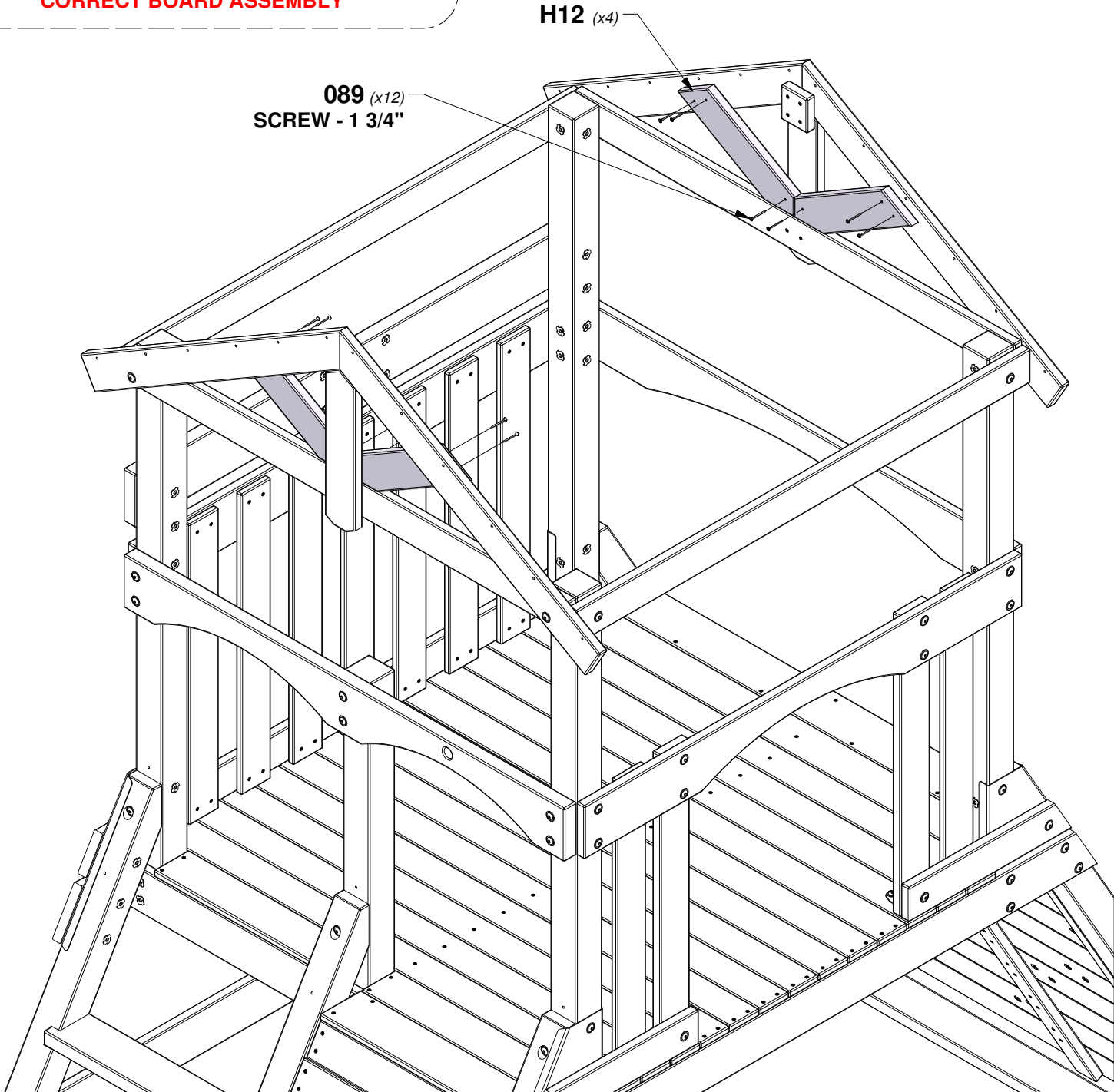
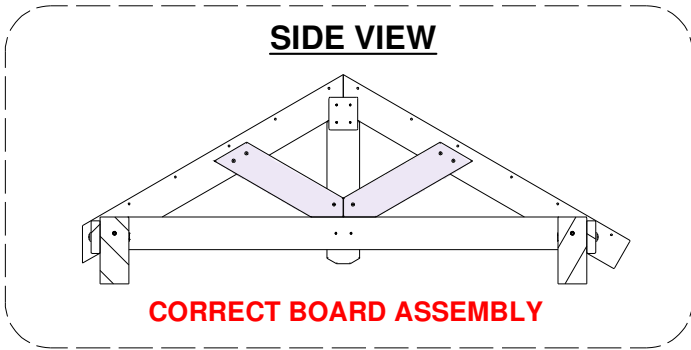

STEP 31 - FORT ASSEMBLY

QTY	PART NUMBER	DESCRIPTION
12	H100091	SCREW PFH 8x2-1/4"



RP1 | ROOF PANEL - W2A03410
(x2) | 1 5/8"x15"x59 1/8" (42x382x1503)

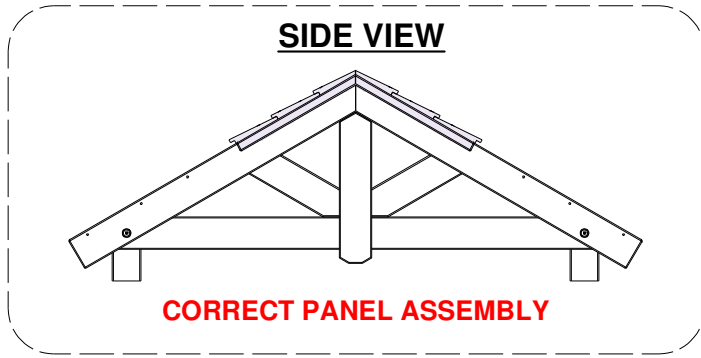

091 (x12)
SCREW - 2 1/4"

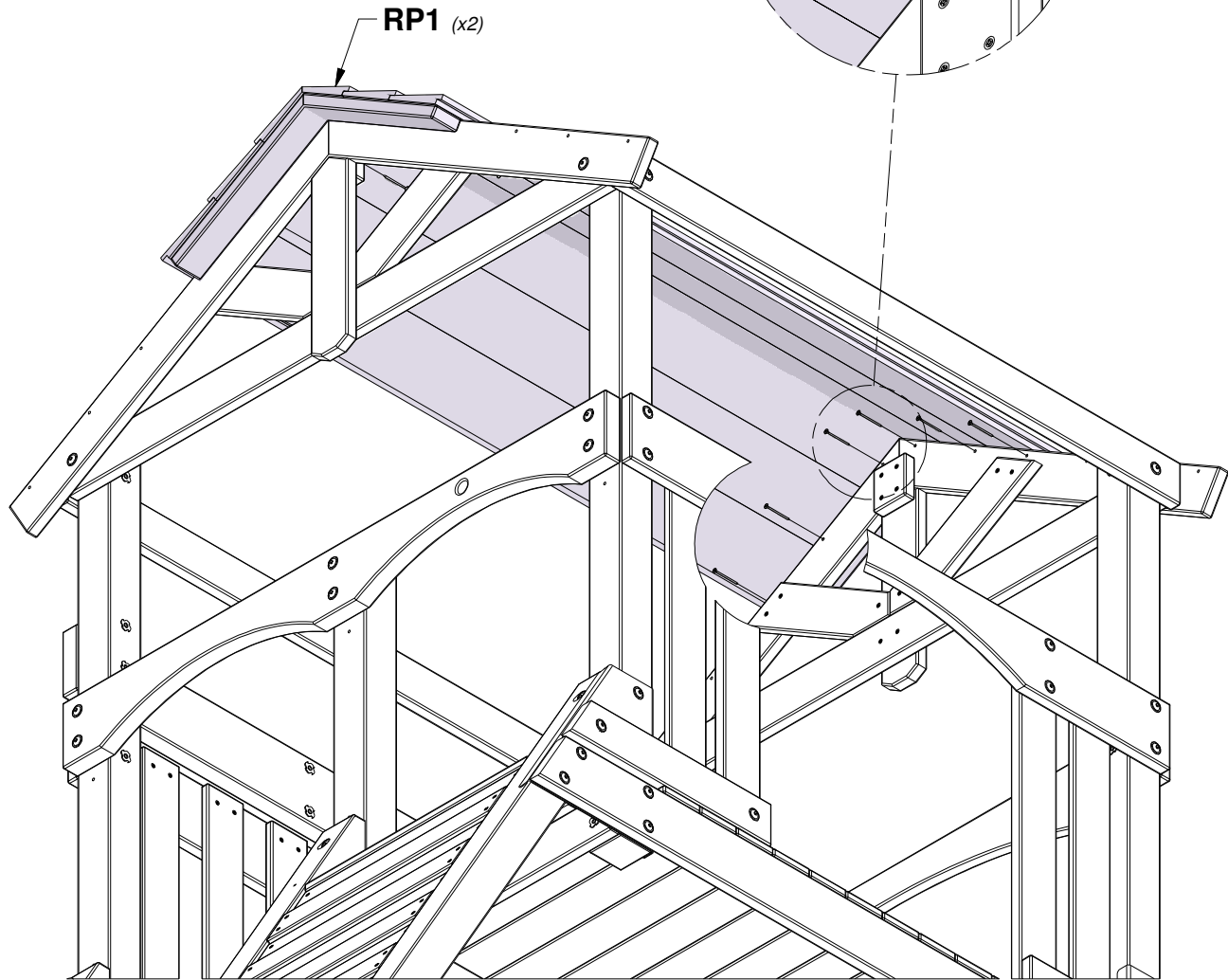
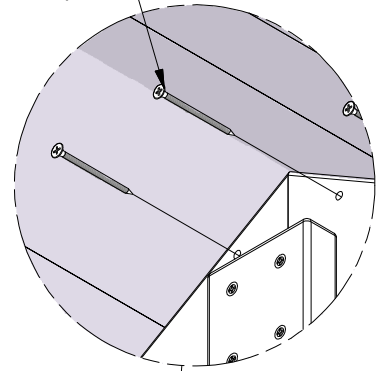

STEP 32 - FORT ASSEMBLY

QTY	PART NUMBER	DESCRIPTION
12	H100091	SCREW PFH 8x2-1/4"

•	•
•	•
•	•
•	•
•	•
•	•
•	•

RP2 | ROOF PANEL - W2A03411
 (x2) | 1 5/8"x20 5/8"x66" (42x524x1503)

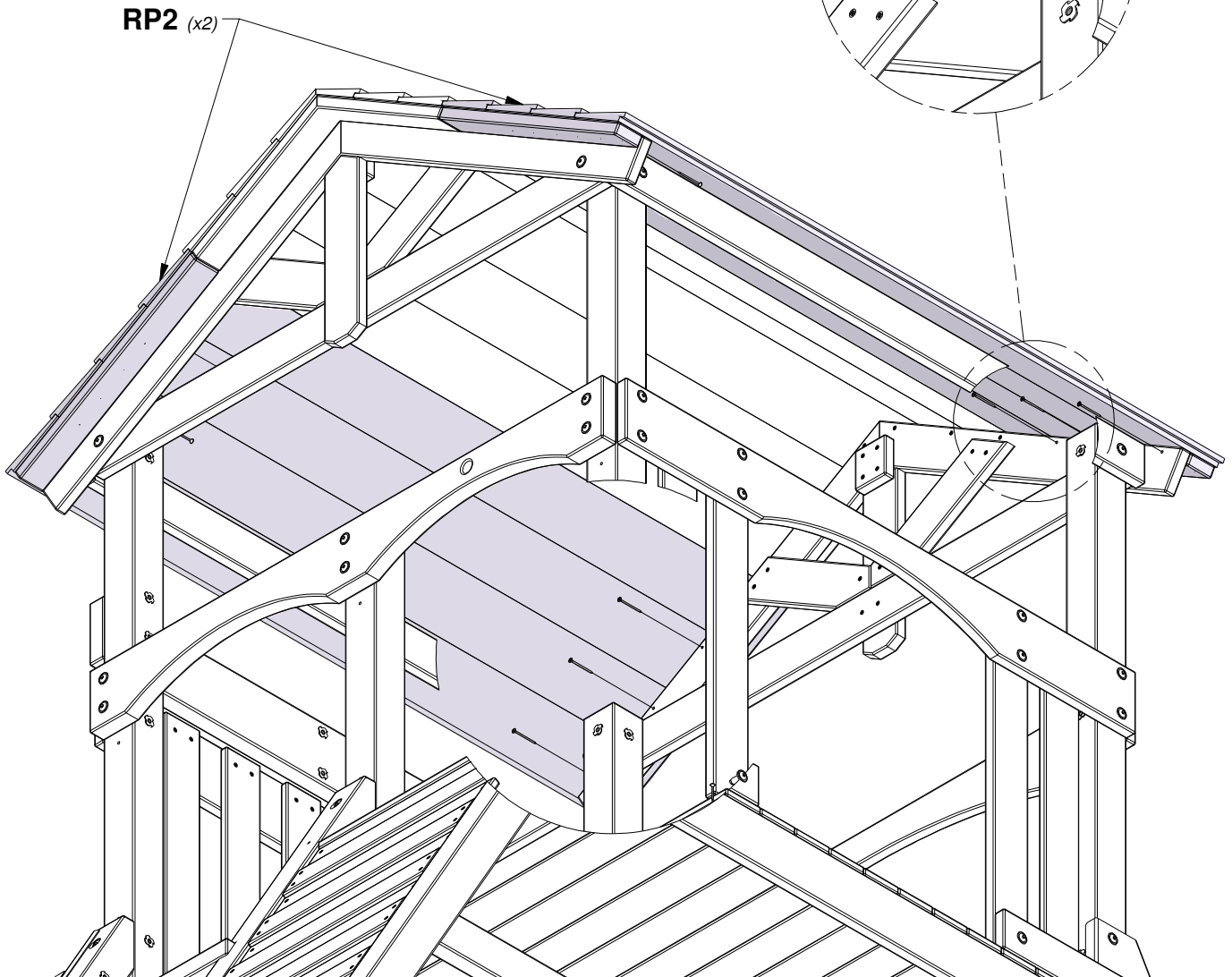
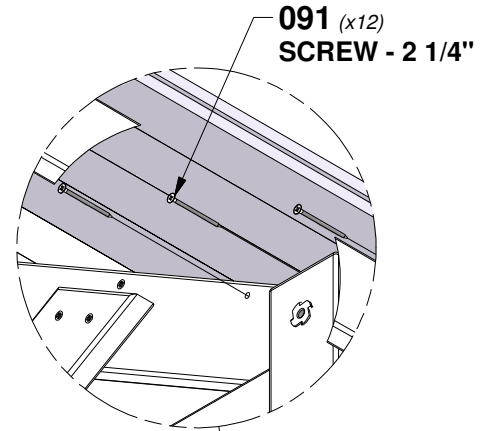
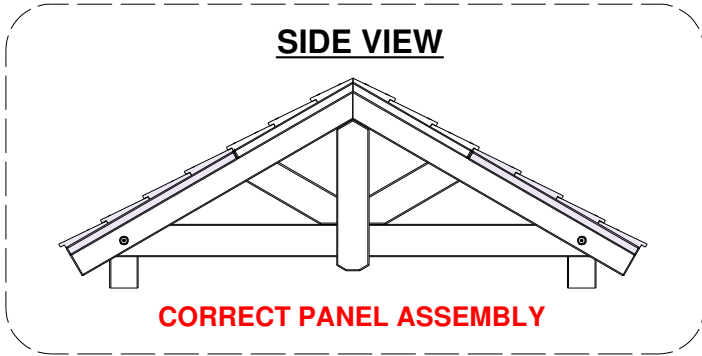

STEP 33 - FORT ASSEMBLY

QTY	PART NUMBER	DESCRIPTION
24	H100380	SCREW PFH 8x1 1/8 BLK



N01 | ROOF CLEAT - W4L16460
 (x4) | 5/8"x2 3/8"x26 5/8" (16x60x675)

BOTTOM VIEW

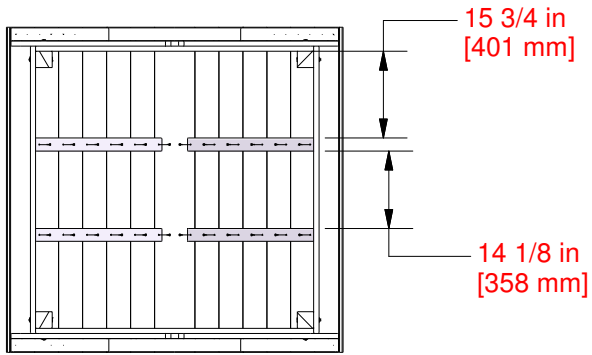

CORRECT BOARD ASSEMBLY

FRONT VIEW

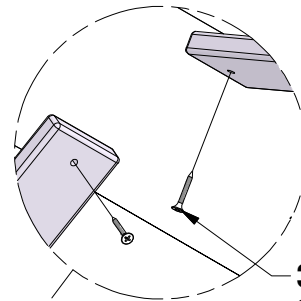
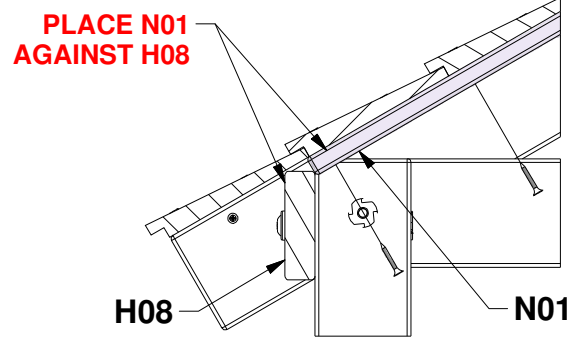

380 (x24)
SCREW - 1 1/8"

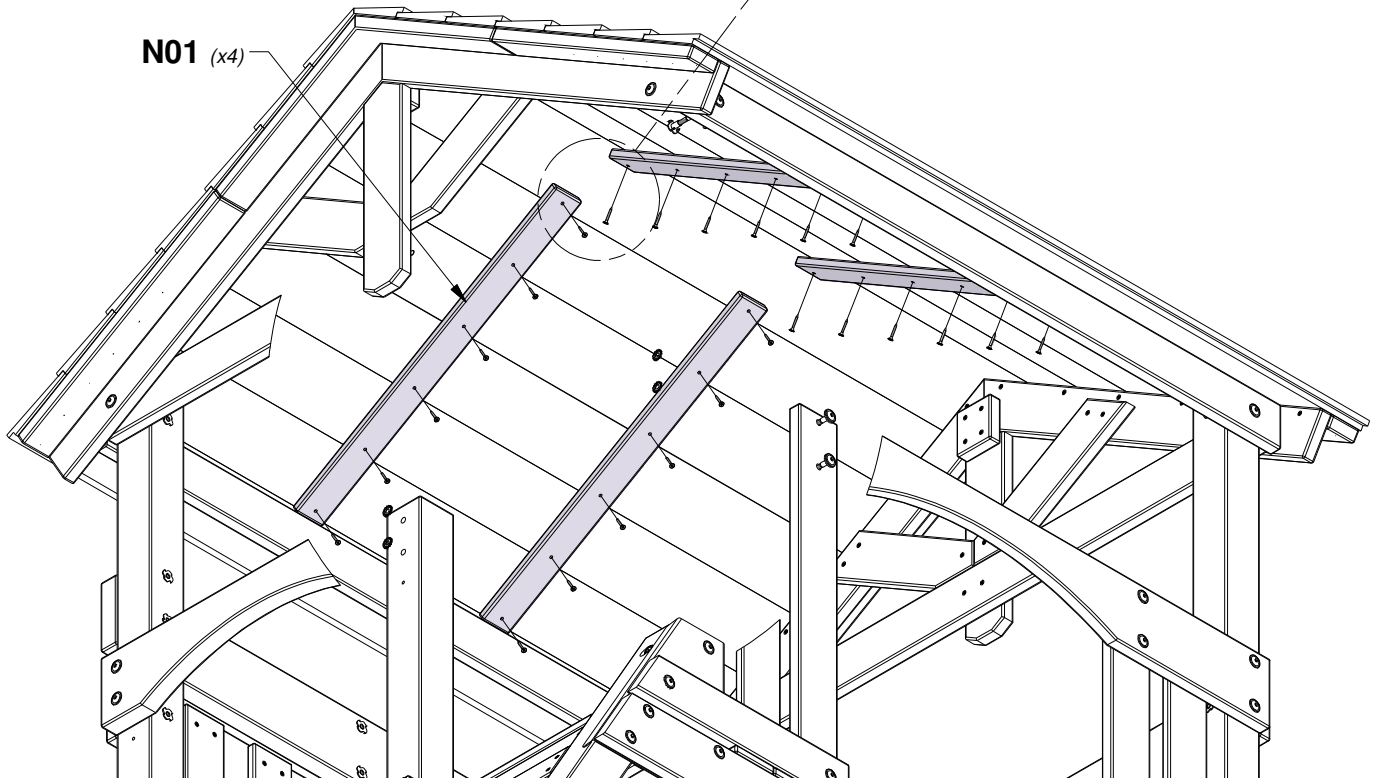

STEP 34 - FORT ASSEMBLY

QTY	PART NUMBER	DESCRIPTION
4	H100027	LAG SCREW WH 5/16x2



A100118 | **HAND GRIP**
(x2) | **METAL GREEN**
381 c/c

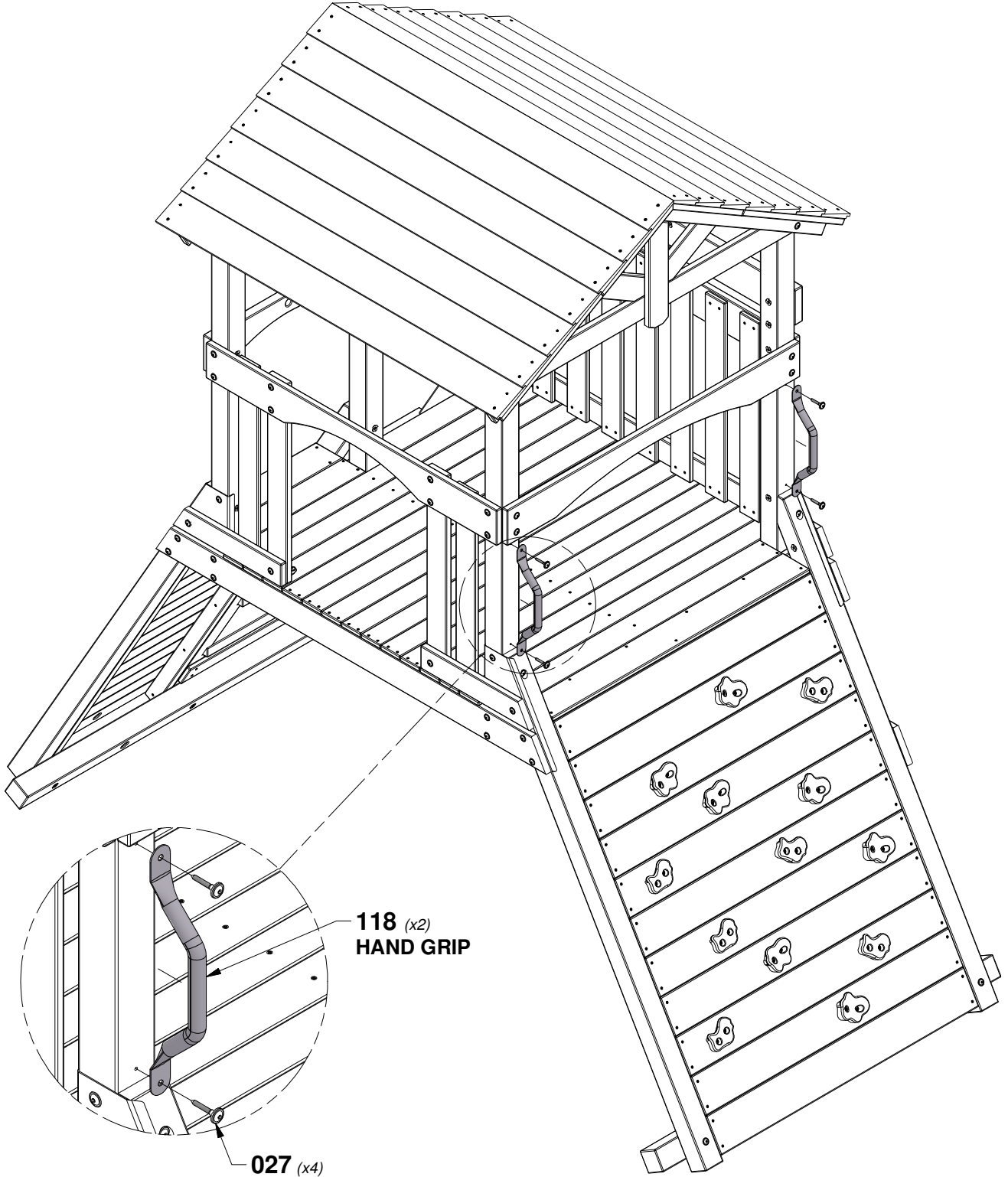

118 *(x2)*
HAND GRIP

027 *(x4)*
LAG SCREW - 2"

STEP 35 - FORT ASSEMBLY

QTY	PART NUMBER	DESCRIPTION
6	H100027	LAG SCREW WH 5/16x2



A100118 | **HAND GRIP**
(x3) | **METAL GREEN**
381 c/c

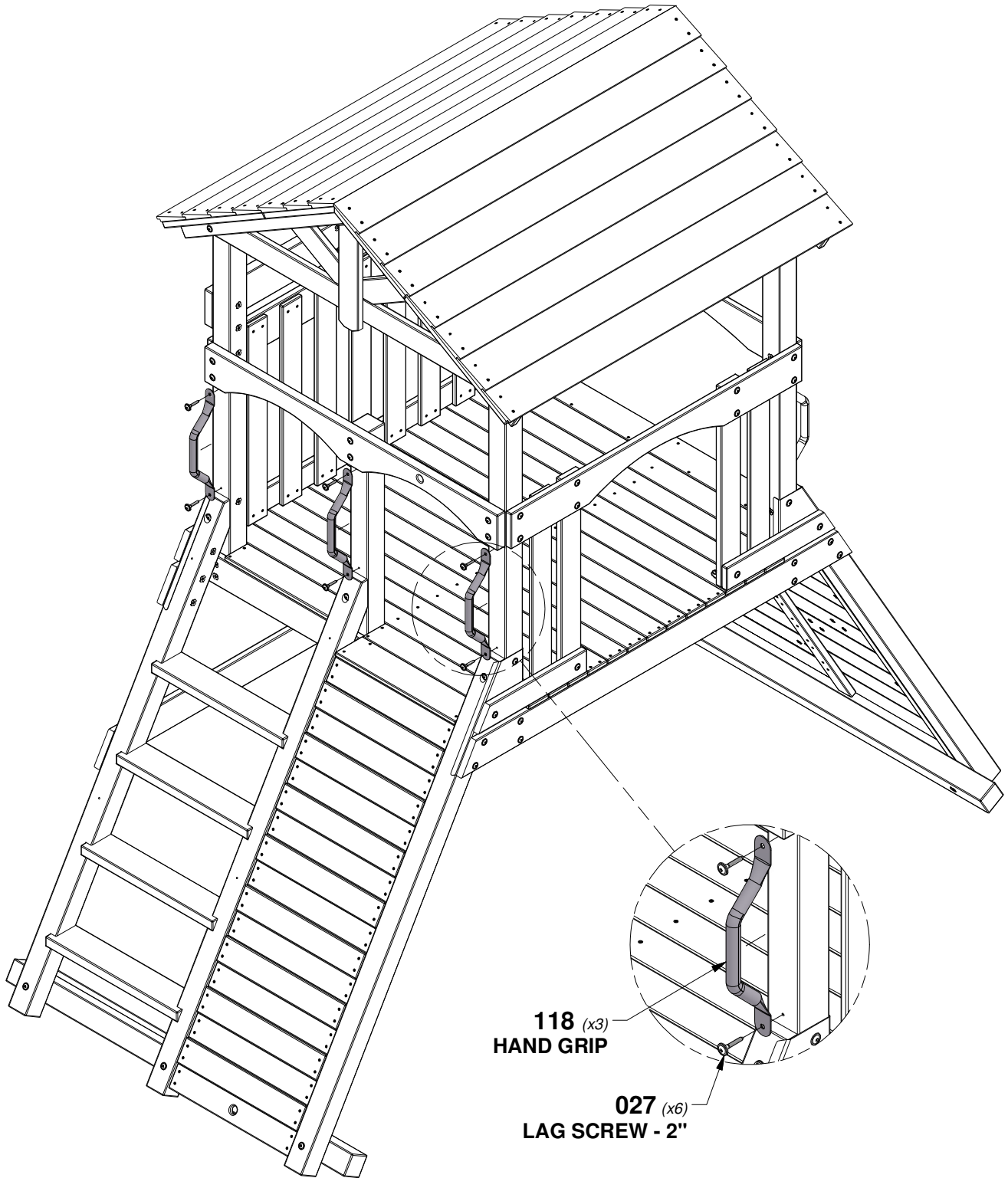

118 *(x3)*
HAND GRIP

027 *(x6)*
LAG SCREW - 2"

STEP 36 - FORT ASSEMBLY

QTY	PART NUMBER	DESCRIPTION
4	H100027	LAG SCREW WH 5/16x2

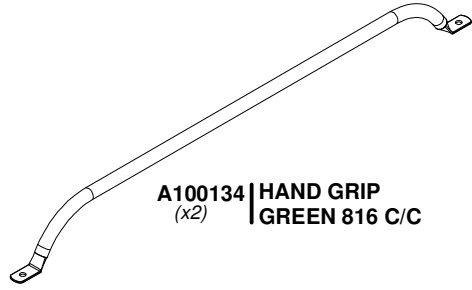

A100134 | **HAND GRIP**
(x2) | **GREEN 816 C/C**

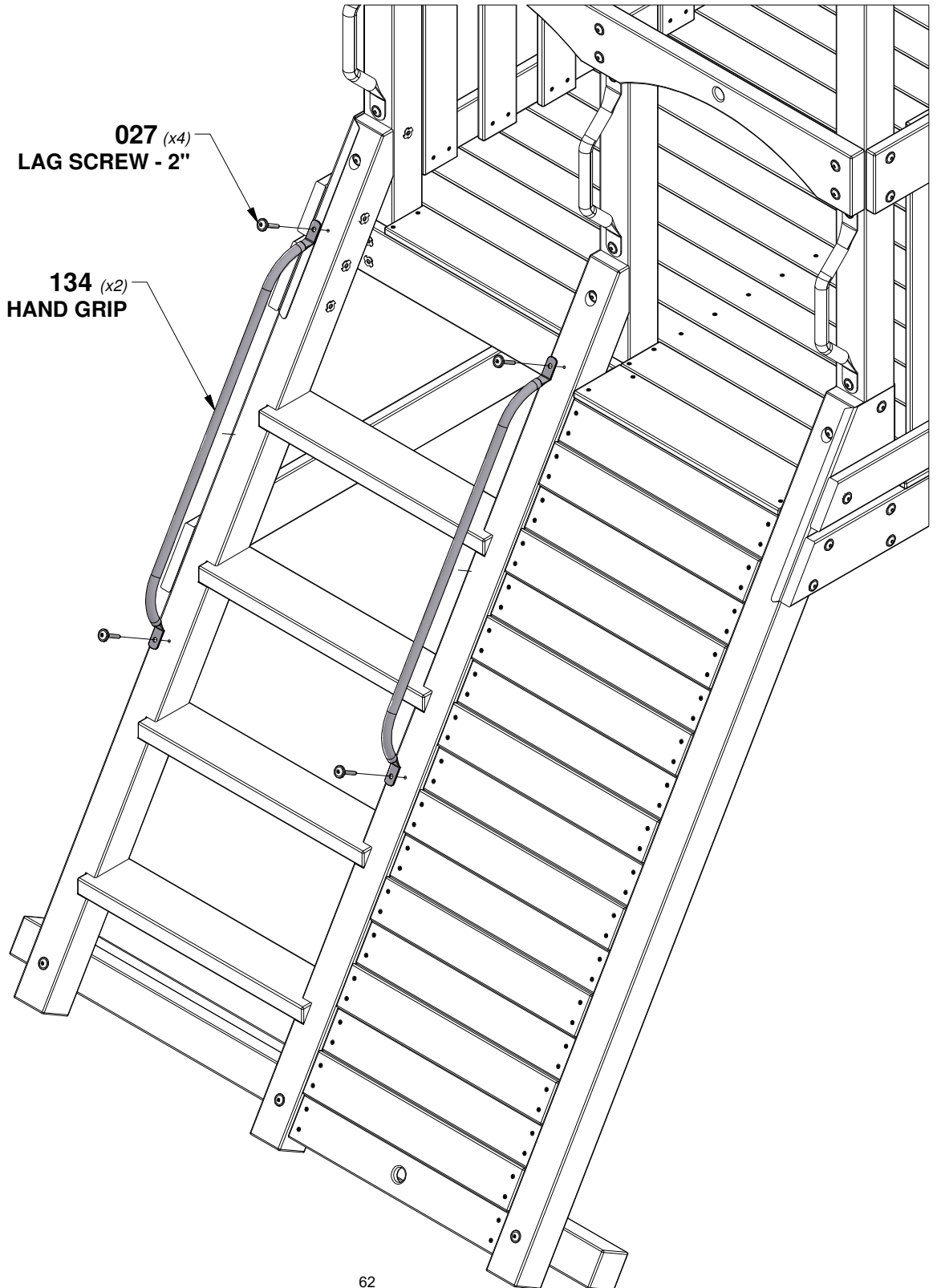

027 *(x4)*
LAG SCREW - 2"

134 *(x2)*
HAND GRIP

STEP 38 - FORT ASSEMBLY

QTY	PART NUMBER	DESCRIPTION
4	H100477	WASHER SPLIT 5/16 BLK
4	H100478	WASHER FLAT 8x27 BLK
4	H100498	BOLT HEX 5/16x1-1/2 - BLK

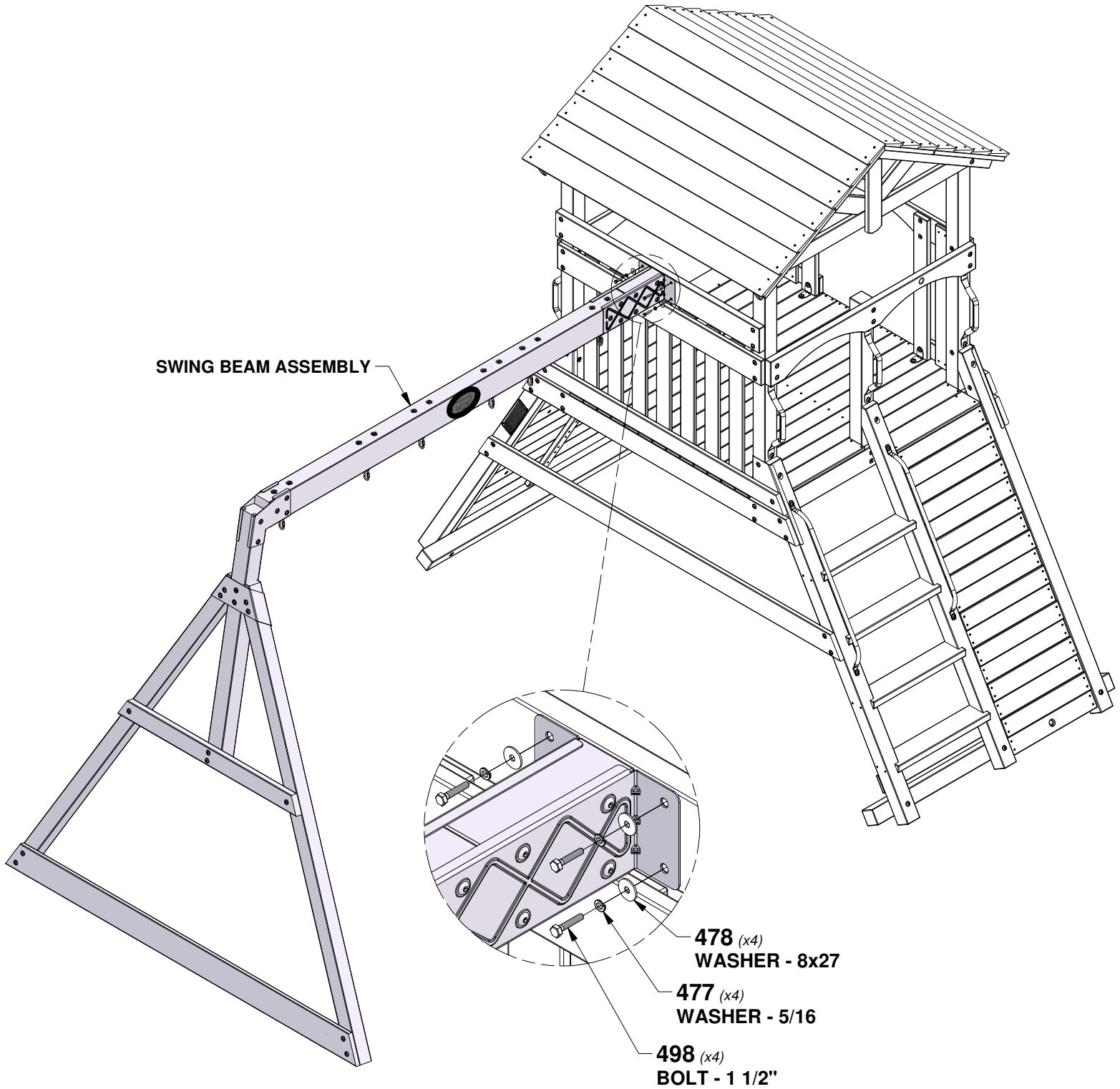
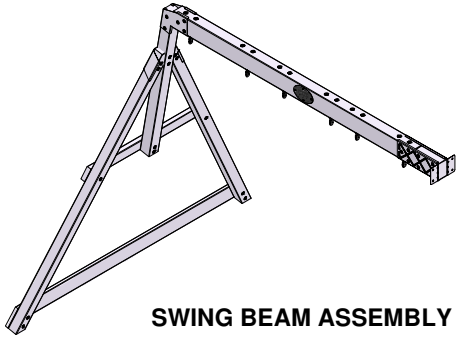

STEP 1 - WEB SWING ASSEMBLY

QTY	PART NUMBER	DESCRIPTION
4	H100831	NUT BARREL PTH BLK 1/4x3/4
4	H100832	BOLT PTH 1/4x3/4

IMPORTANT: SLIDE ROPE LOOPS OVER TUBE ENDS FIRST!

SLIDE NARROW END OF TUBES INTO LARGER OPENING AFTER SLIDING ROPE LOOPS ONTO TUBES.

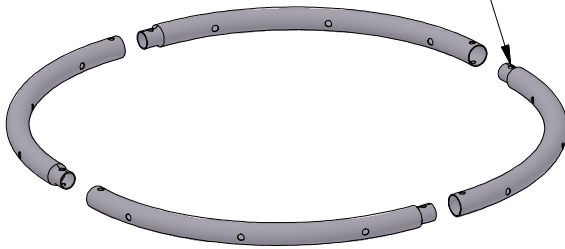

NOTE: ROPE WEBBING NOT SHOWN IN ILLUSTRATION FOR CLARITY.

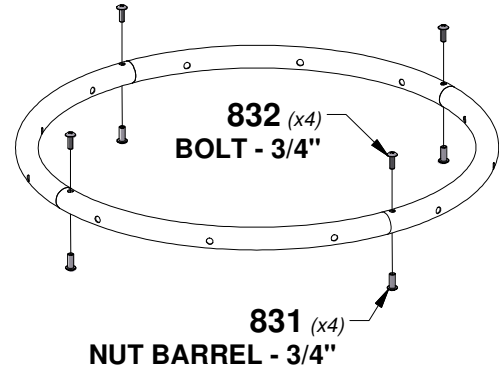

NOTE: IT IS IMPORTANT THAT THE WEB SWING HANG LEVEL.

TO ENSURE STRAIGHT SWINGING MOTION, ADJUST BOTH "S" BRACKETS UNTIL WEB SEAT IS LEVEL.

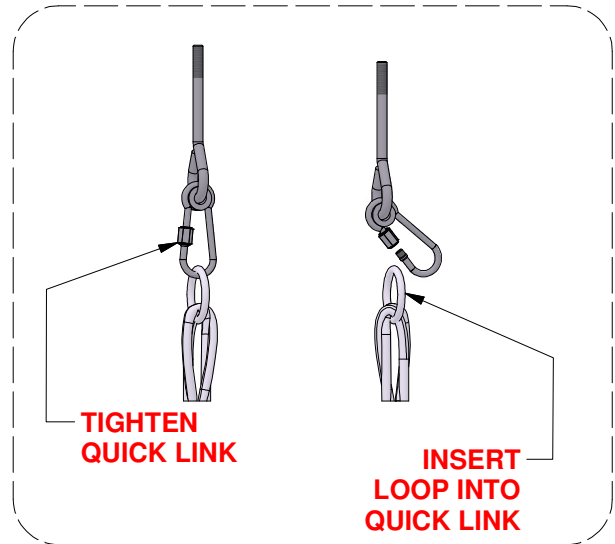

SWING MUST BE SET AT A MINIMUM OF 8 INCHES OFF THE GROUND WHEN INSTALLED.

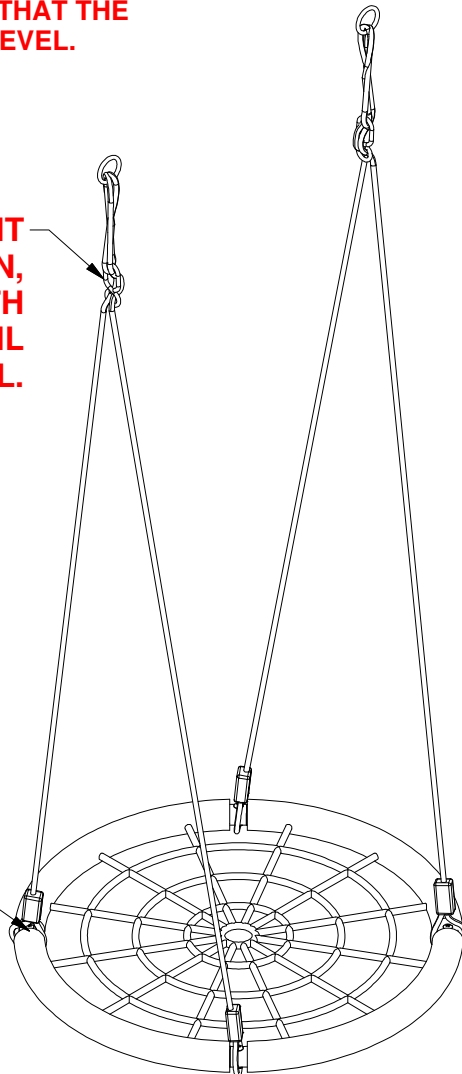

STEP 39 - FORT ASSEMBLY



A100027 | SWING SEAT
(x2) | GREEN 26"



A100069 | QUICK LINK
(x4)

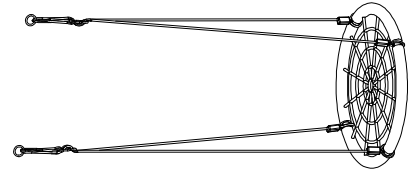

A4M01126 | 26" WEB SWING
(x1) | SEAT ROPE

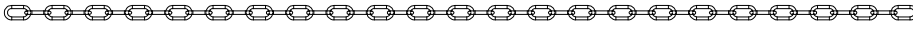

A100047 | CHAIN GREEN
(x4) | 57"

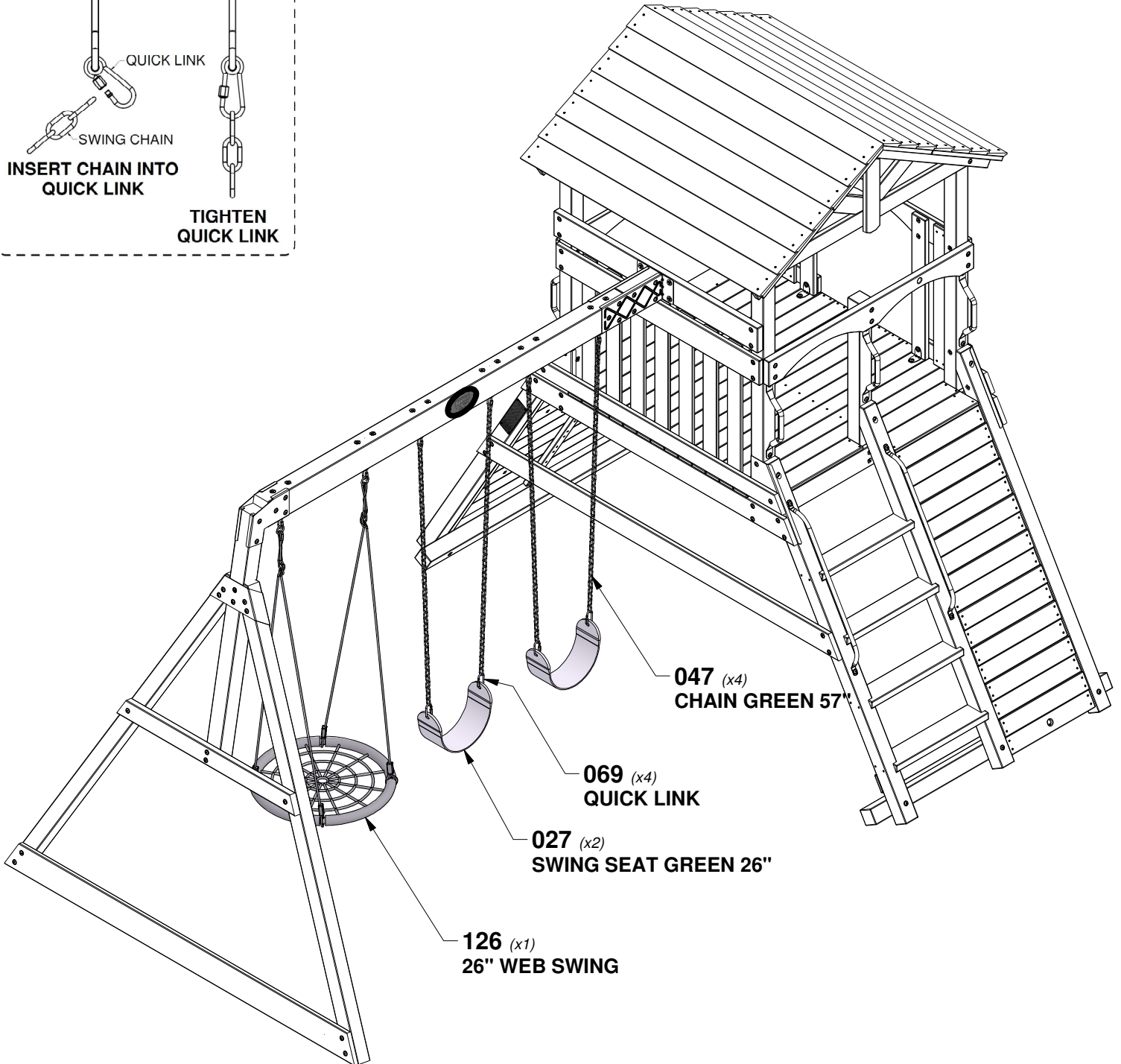
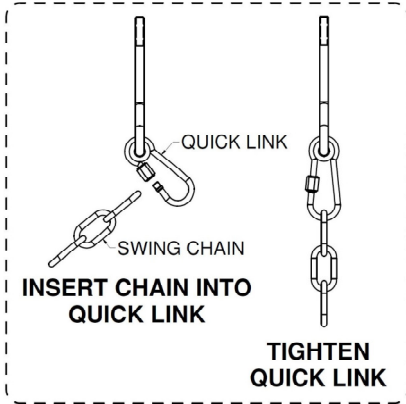

STEP 1 - ROPE CLAMP ASSEMBLY

ROPE CLAMP ATTACHED IN NEXT STEP.

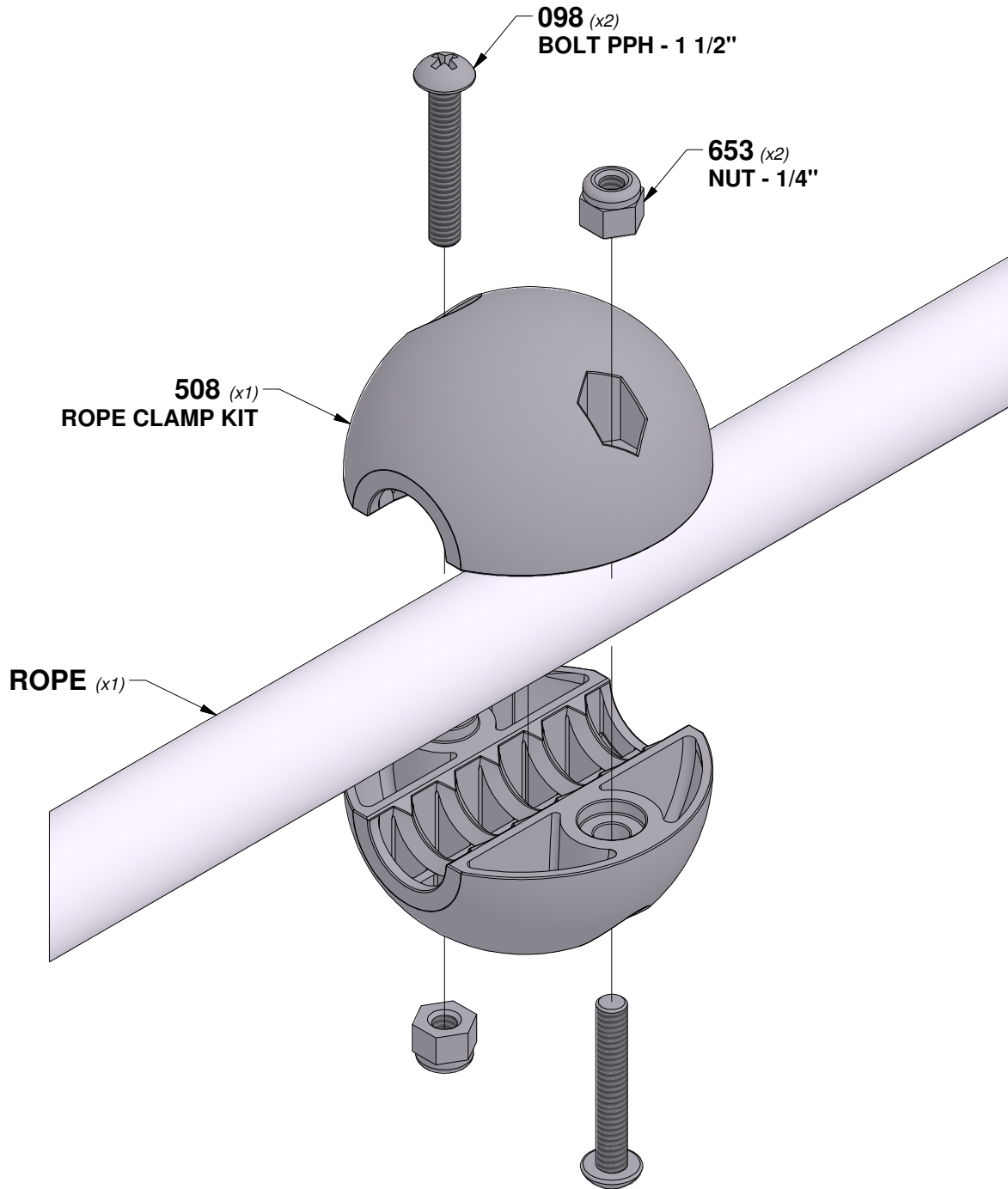

STEP 40 - FORT ASSEMBLY

A6P00508
(x7) ROPE CLAMP KIT

A6P00520
(x1) ROPE

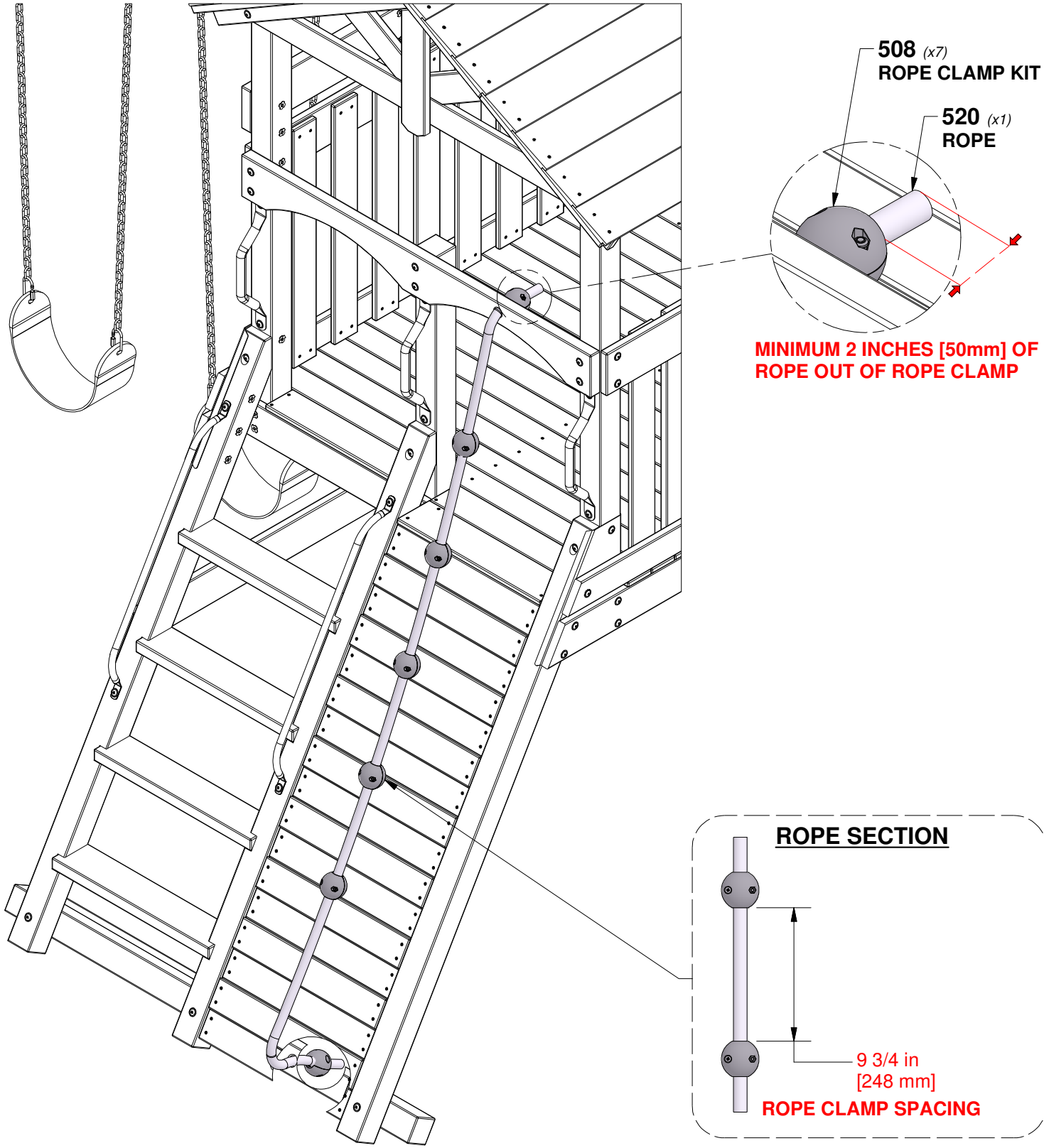

STEP 41 - FORT ASSEMBLY

QTY	PART NUMBER	DESCRIPTION
2	H100086	SCREW PFH 8x1-1/2"

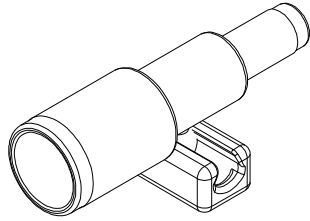

A6P00096 | TELESCOPE
(x1)

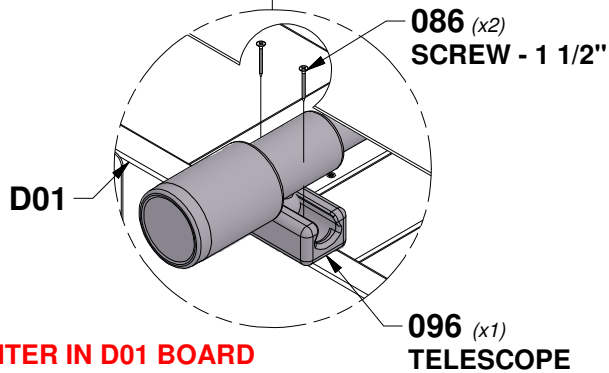
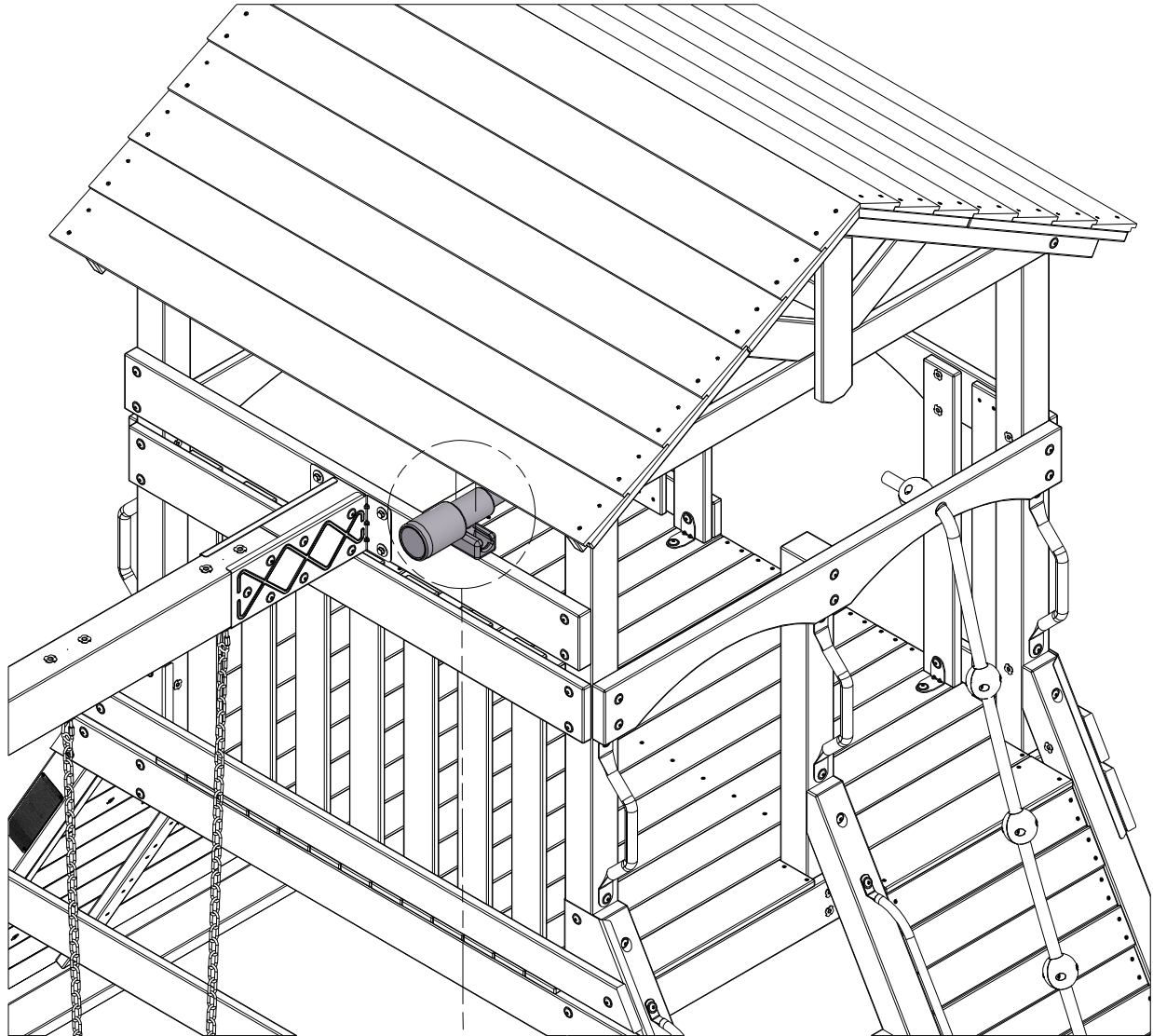

CENTER IN D01 BOARD

STEP 42 - FORT ASSEMBLY

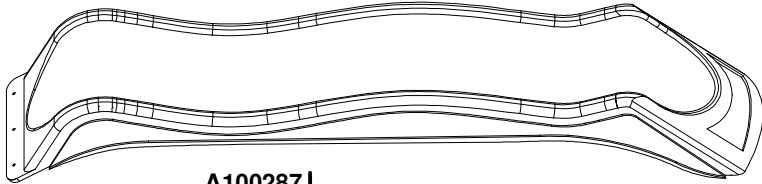

A100287 (x1) | **SLIDE VF 10 FT**

QTY	PART NUMBER	DESCRIPTION
3	H100009	BOLT WH 5/16x1 1/4
3	H100074	T-NUT 5/16"
4	H100088	SCREW PFH 8x1 1/8

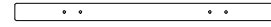

O70 (x1) | **SLIDE MOUNTING BOARD - W4L09040**
(x1) | 5/8"x1 3/8"x20 3/8" (16x34x517)

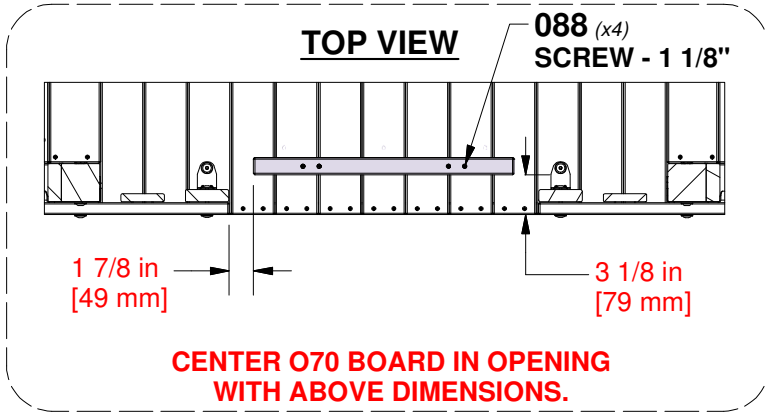

CENTER SLIDE IN OPENING OVER O70 BOARD. USING SLIDE & O70 AS A GUIDE, DRILL (3) 3/8" [10 mm] HOLES THRU FLOOR FOR HARDWARE.

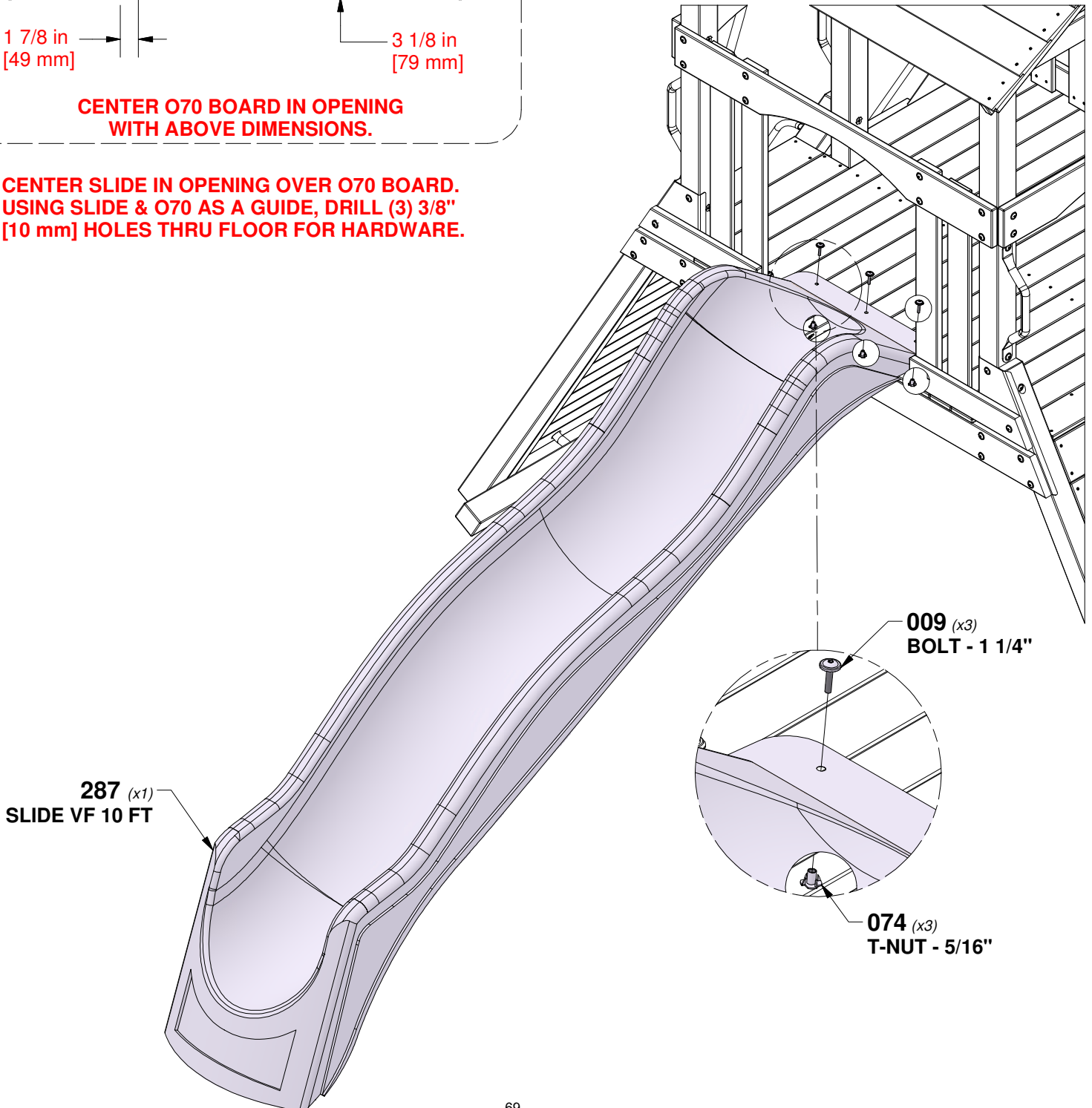

STEP 43 - FORT ASSEMBLY

QTY	PART NUMBER	DESCRIPTION
2	H100004	NUT BARREL WH 5/16x5/8
2	H100008	BOLT WH 5/16x1
4	H100028	LAG SCREW WH 5/16x2 1/2
2	H100031	WASHER LOCK EXT 12x19

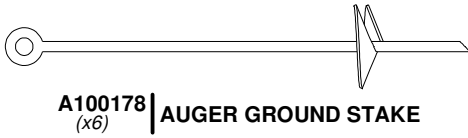

A100178
(x6) | AUGER GROUND STAKE

DETAIL - A

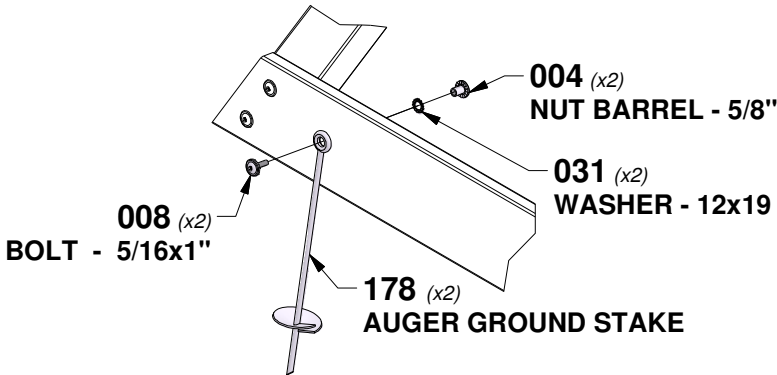

TWIST GROUND STAKE INTO GROUND AT LOCATIONS SHOWN. USING GROUND STAKE AS A GUIDE, DRILL A 7/16" [10mm] HOLE FOR HARDWARE.

DETAIL - A

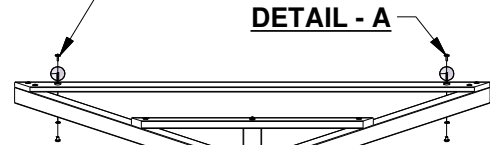

DETAIL - A

DETAIL - B

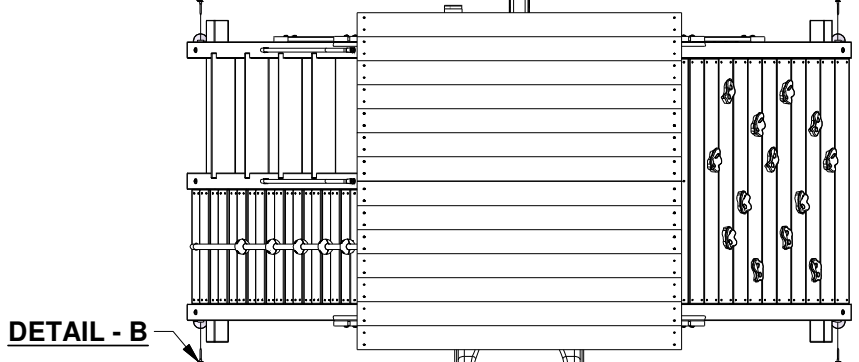

DETAIL - B

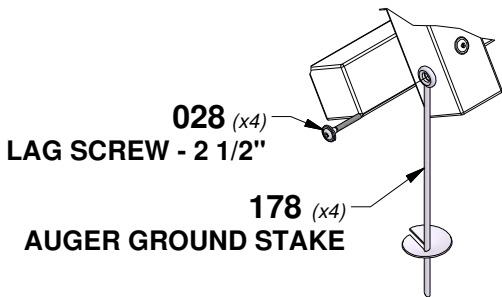

TWIST GROUND STAKE INTO GROUND AT LOCATIONS SHOWN. USING GROUND STAKE AS A GUIDE, DRILL A 3/16" [5mm] PILOT HOLE FOR LAG BOLT.