

Product Specifications

20.0 Liter Square Tight Head with Integrated Handle

Product Uses

Liquid Products

Product Codes

Container: **STH Series**

Description: 20L Square Tighthead

Features

UN Rating: 3H1/Y1.8/100

Nominal capacity: 5.3 USG / 20.0L

Maximum capacity: 5.65 USG / 21.4 L

Tare weights: 2.73 lbs / 1.24 kgs

Colors

Standard: White, Black, Blue and Natural

Custom: Available at manufacturer's discretion

Decorating Options

Maximum Label Area:

Perimeter: 38-1/4" x 8-11/16" H

See Salesperson for Options

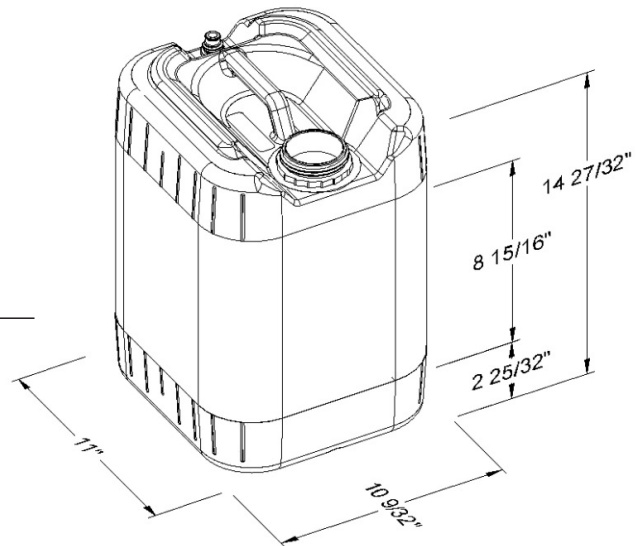

Shipping Data

Qty. per floor spot:

Gross Weight (lbs./kgs)*:

Length (in./cm.):

Width (in./cm.):

Height (in./cm.):

Containers

112

306 / 139

44 / 112

33 / 84

107 / 273

Filled Containers

Refer to BWAY document # ETS-CD-1002 for storage and shipping recommendations.

Estimated truckload quantity of 3,360 containers**

Notes: *Weight does not include pallet / packaging
**Truckload quantity based on 53' trailer

Materials

FDA approved materials

Resin: Body: High-Density Polyethylene (HDPE)

MSDS Sheets available upon request

Optional Carrying Handle

Integral

DISTRIBUTED BY:



REF NO.:

DWG31693

DESCRIPTION:

20 Liter HDPE Square TH Pail, 70mm TE Opening with Integrated Handle

DISCLAIMER

THIS INFORMATION IS PROVIDED AS A GENERAL GUIDE, INCLUDING DIMENSIONS. IT IS THE CUSTOMER'S RESPONSIBILITIES TO SELECT THE PROPER CONTAINER FOR PRODUCT AND APPLICATION COMPATIBILITY.