

Features an integrated overflow.

MODEL 222
66.75" x 28.75" x 19.5"/20.5"
FREESTANDING 69 gal to overflow
<b>SculptureStone®</b>
213 lbs / 97 kg soaker 243 lbs / 110 kg airbath
Filling this tub to the maximum may require an above average size or dedicated water heater.

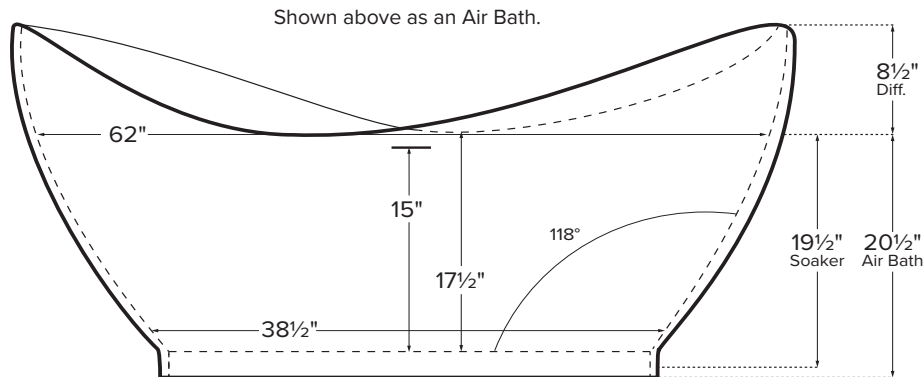
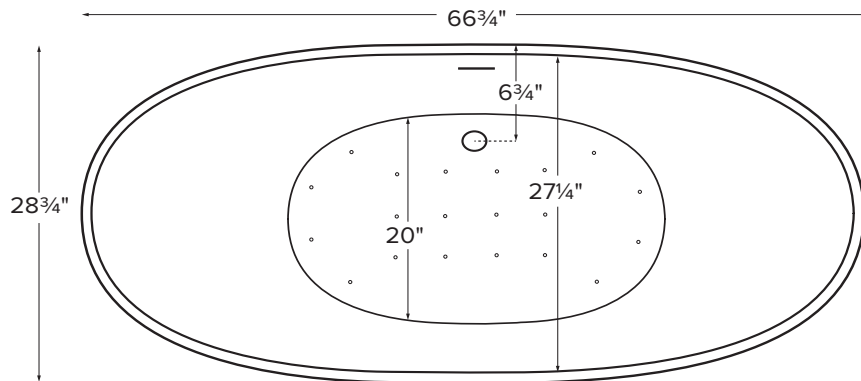

Shown above as an Air Bath.

**ELECTRICAL COMPONENTS & SPECIFICATIONS**

Required Electrical Service - 110 Volt

Hydrotherapy Package	Components Included	GFCI
Air Massage	heated blower	1-15 amp

Electrical requirements may change with the addition of optional therapy components. See specific option details or installation information. CSA Certified C/US; ANSI Z124.1 and ANSI 112.19.7 and ANSI 112.19.7

See the Installation & Operation Manual for more details. MTI's Customer Service: Monday-Friday 8am-6pm EST **800-783-8827** or [service@mtibaths.com](mailto:service@mtibaths.com)

**IMPORTANT ORDERING & INSTALLATION INFORMATION**

- Before ordering or installing, please consider future access to equipment.
- Includes an integrated overflow with toe tap drain in chrome finish. May be specified without an overflow (see local codes before ordering without an overflow).
- Air baths require job site preparation for remote installation of the blower and required check valve. Check valve must be installed higher than the rim of the tub.
- Waterproof remote control included with air bath. Keypad shipped loose may be remote mounted on nearby surface/wall.
- Faucet valves cannot be mounted on this tub model.

- Before discarding tub crate, check for accessories that may be packaged inside.
- All product measurements are ±1/2".
- Specifications and configurations are subject to change without notice.
- Measurements herein supersede all others published prior to publication date below.

