



Manufactured by:  
Backyard Discovery  
3305 Airport Drive, Pittsburg,  
KS 66762 800-856-4445

Basepoint Business Centre: Rivermead Drive, Westlea, Swindon SN5 7EX Phone: 0800-118-2476  
J.P. Coenstraat 7, The Bridge, The Hague, 2595 WP, Netherlands Phone: 08005678990

# 9x6 WHITE BELLEROSE GREENHOUSE

## MODEL # : 2304185

### For Horticulture Use Only



Please visit [www.backyarddiscovery.com](http://www.backyarddiscovery.com)  
For the most up to date assembly manual, to register your product, or to order replacement parts *Para obtener instrucciones en español, visite*  
[www.backyarddiscovery.com](http://www.backyarddiscovery.com)



EASY STEP-BY-STEP  
3D INTERACTIVE INSTRUCTIONS  
DOWNLOAD THE FREE APP



# OWNER'S MANUAL - BASIC SETUP DIMENSIONS & ASSEMBLY NOTES

It is critically important that you start with square and level footings or concrete pad to attach your structure

- Pay close attention to the items needed for each step. Make sure you are using the correct hardware for each step.
- Using incorrect hardware may result in improper assembly
- Remember to double check for underground utilities and overhead electrical lines
- The hardware to attach the post mounts to the structure is included.
- The hardware to mount the structure permanently to a concrete surface is included.

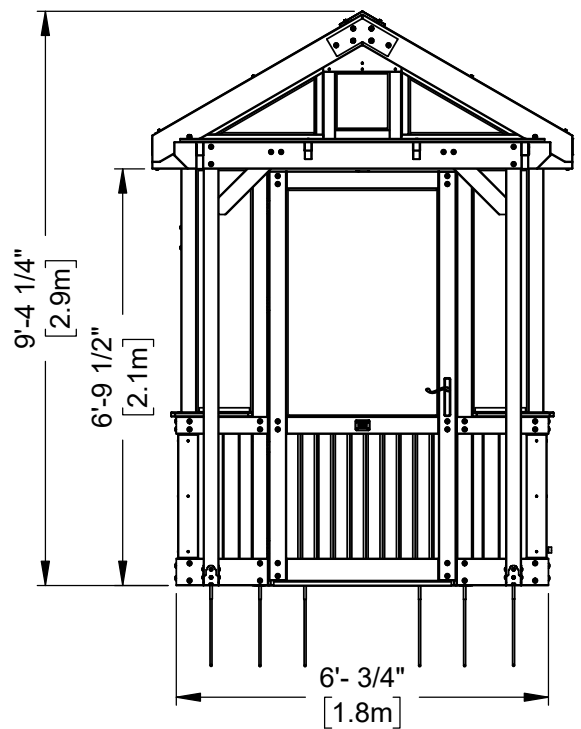
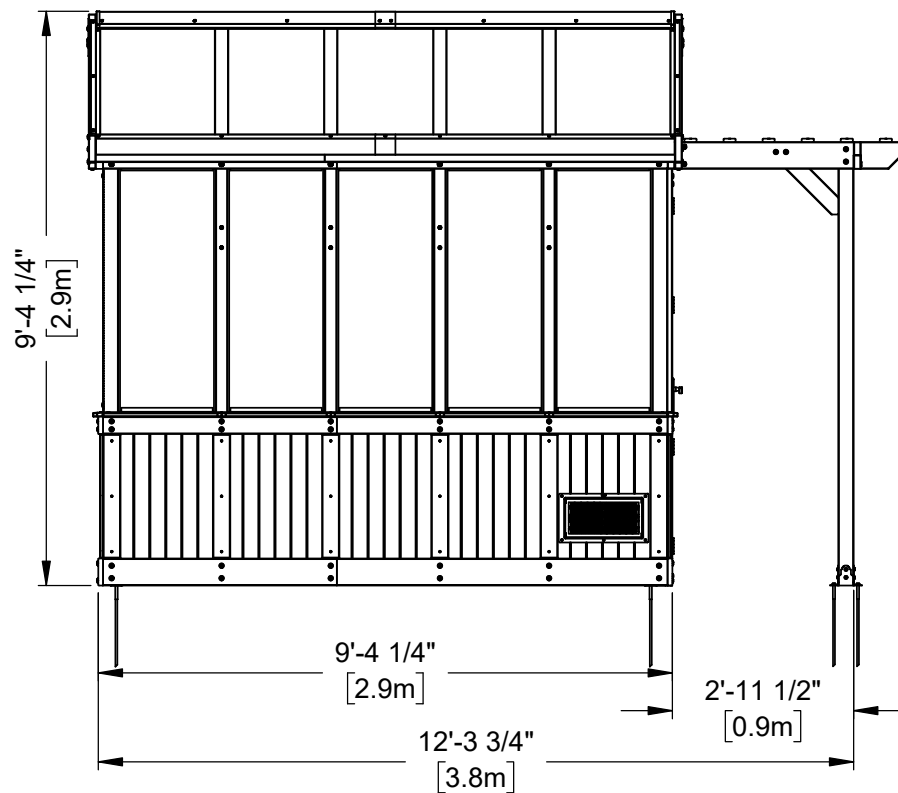
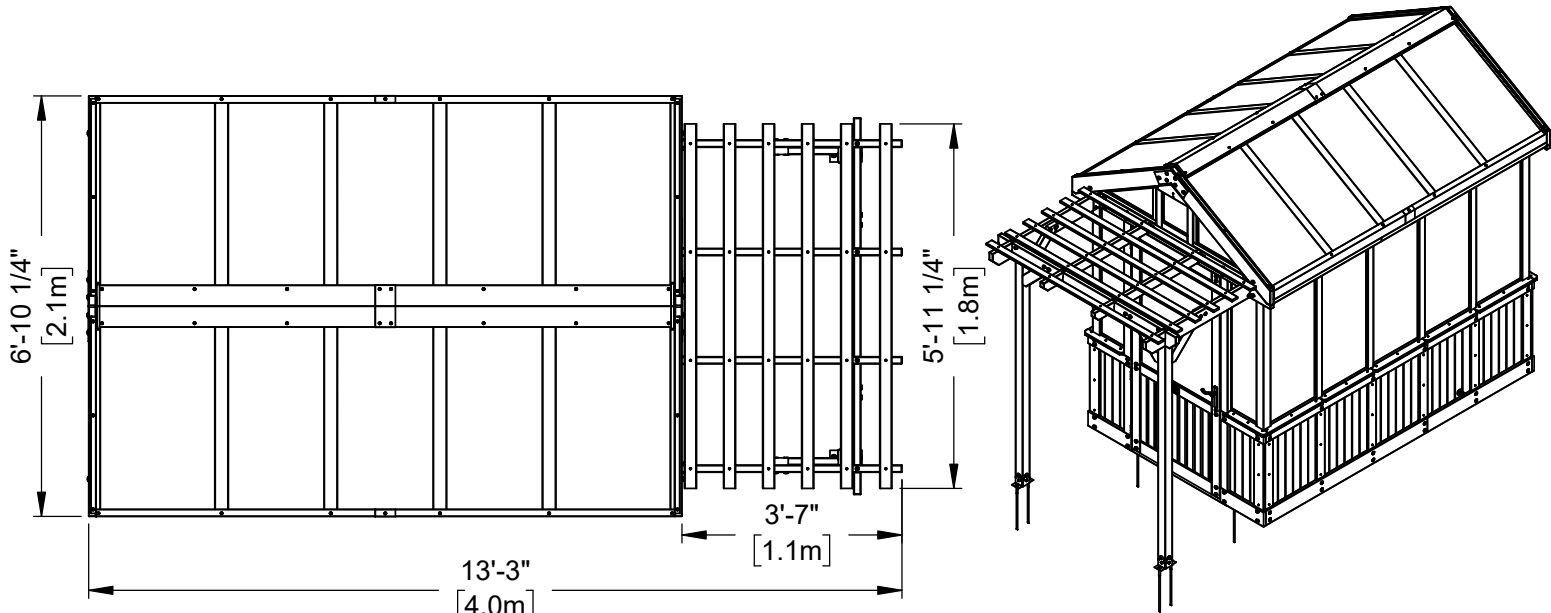

# OWNER'S MANUAL - ANCHORING LAYOUT

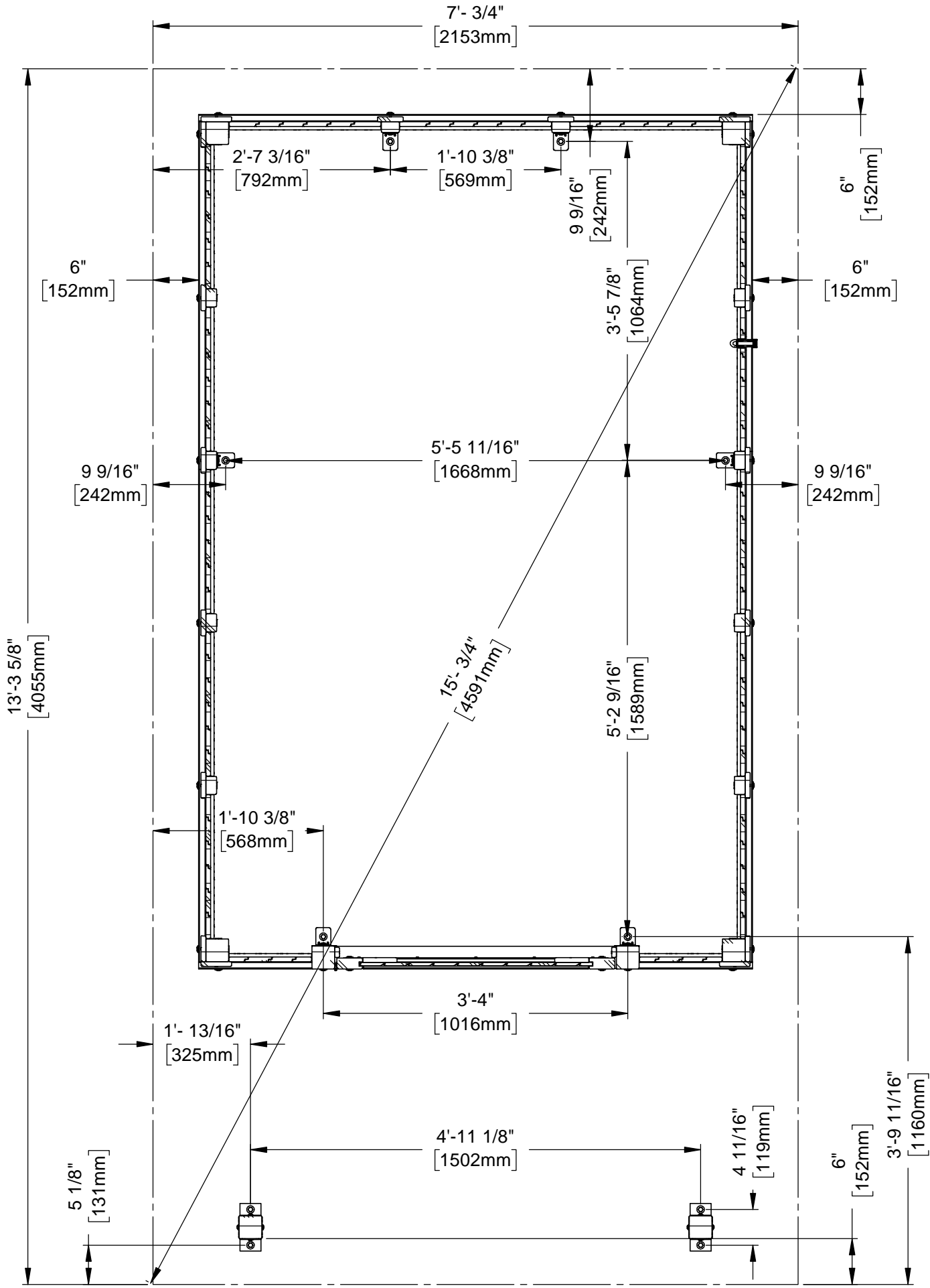

# OWNER'S MANUAL - SITE LOCATION AND PREPARATION

- A. Check your local building and city codes for permit requirements or restrictions, including any HOA restrictions.
- B. Select a location with lots of sun, good drainage, and the ability to create a level firm surface for your greenhouse.
  - A firm, level surface is critically important to the longevity of your greenhouse.
  - Ensure it is accessible on all sides to clean and conduct annual maintenance
  - Consider a site location with a close proximity to both water and electrical sources
  - Make sure site drains well and avoid low lying areas.
  - Recommended area for site preparation of the White Lilybelle Greenhouse is 13'-3 5/8" x 7'- 3/4" x 9'-4 1/4" (4055mm x 2153mm x 2848mm).
- C. Before preparing your surface – double check for possibility of any underground utilities (example: gas, cable, or sprinkler lines)
  - Remove any grass, dirt, landscaping to create a level, hard-packed surface
  - This may involve some digging to create a level spot, dependent on your site location.
- D. Determine your preferred site pad materials for your greenhouse
  - It is NOT recommended to set the greenhouse directly on soil or grass. This will shorten the lifespan of your greenhouse.
  - Site pad options include gravel, patio or brick pavers, concrete pad.
  - Anchors are included for either natural surface, such as gravel, or for a concrete foundation.
  - Manufacturer recommends installation on concrete surface or concrete post pads.

# OWNER'S MANUAL - PARTS IDENTIFICATION

## WOOD COMPONENTS (NOT TO SCALE)

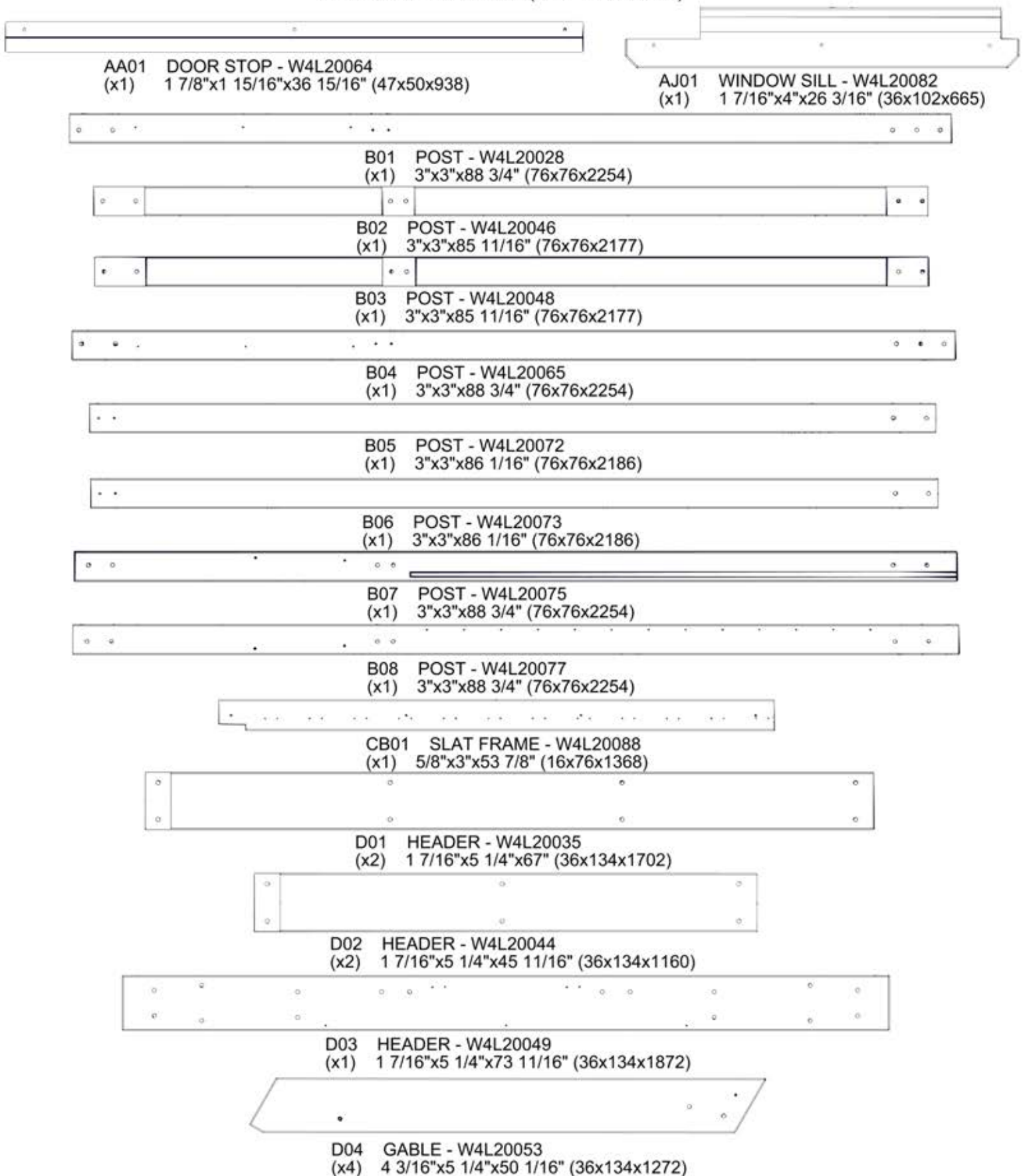

# OWNER'S MANUAL - PARTS IDENTIFICATION

## WOOD COMPONENTS (NOT TO SCALE)



D06 END TRIM - W4L20062  
(x4) 1 7/16"x134x219 (36x134x219)



D07 PERGOLA BEAM - W4L20068  
(x1) 1 7/16"x5 1/4"x73 5/8" (36x134x1870)



D08 PERGOLA RAFTER - W4L20069  
(x2) 1 7/16"x5 1/4"x44 7/16" (36x134x1128)



D09 HEADER - W4L20083  
(x1) 1 7/16"x5 1/4"x73 11/16" (36x134x1872)



E01 WINDOW SILL - W4L20032  
(x2) 1 7/16"x3 3/8"x23 1/8" (36x86x588)



E02 WINDOW SILL - W4L20033  
(x6) 1 7/16"x3 3/8"x21 5/16" (36x86x542)



E03 WINDOW SILL - W4L20034  
(x2) 1 7/16"x3 3/8"x23 1/8" (36x86x588)



E04 WINDOW SILL - W4L20051  
(x1) 1 7/16"x3 3/8"x15 7/8" (36x86x403)



E05 WINDOW SILL - W4L20052  
(x1) 1 7/16"x3 3/8"x15 7/8" (36x86x403)

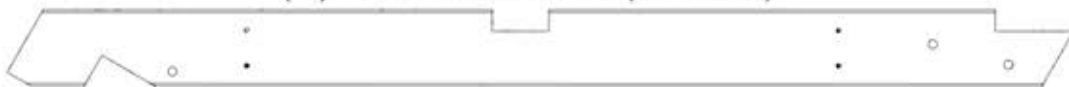

E06 RAFTER - W4L20055  
(x4) 1 7/16"x3 3/8"x47 3/8" (36x86x1203)



E07 PERGOLA RAFTER - W4L20070  
(x2) 1 7/16"x3 3/8"x44 7/16" (36x86x1128)



E08 ANGLE BRACE - W4L20074  
(x4) 1 7/16"x3 3/8"x18 11/16" (36x86x474)



E09 WINDOW SILL - W4L20081  
(x1) 1 7/16"x3 3/8"x26 3/16" (36x86x665)



E10 FAN FRAME - W4L20093  
(x1) 1 7/16"x3"x10 9/16" (36x76x268)



E11 WINDOW SILL - W4L20100  
(x1) 1 7/16"x3 3/8"x22 5/16" (36x86x567)

# OWNER'S MANUAL - PARTS IDENTIFICATION

## WOOD COMPONENTS (NOT TO SCALE)



E12 RAFTER - W4L20103  
(x4) 1 7/16"x3 3/8"x46 5/16" (36x86x1176)



E13 RAFTER - W4L20104  
(x4) 1 7/16"x3 3/8"x46 5/16" (36x86x1176)



E14 ACCESSORY TRUSS - W4L20111  
(x2) 1 7/16"x3 3/8"x54 1/8" (36x86x1375)



F01 UPRIGHT - W4L20030  
(x4) 1 7/16"x2 3/8"x86 11/16" (36x60x2202)



F02 ANGLE BRACE - W4L20039  
(x6) 1 7/16"x2 3/8"x18 1/16" (36x60x458)



F03 ANGLE BRACE - W4L20040  
(x3) 1 7/16"x2 3/8"x18 1/16" (36x60x458)



F04 WINDOW FRAME - W4L20115  
(x1) 1 7/16"x2 3/8"x16 5/8" (36x60x422)



F05 WINDOW FRAME - W4L20116  
(x1) 1 7/16"x2 3/8"x16 5/8" (36x60x422)



F07 WINDOW FRAME - W4L20056  
(x1) 1 7/16"x2 3/8"x10 9/16" (36x60x268)



F06 WINDOW FRAME - W4L20058  
(x1) 1 7/16"x2 3/8"x10 9/16" (36x60x268)



F08 UPRIGHT - W4L20066  
(x4) 1 7/16"x2 3/8"x86 11/16" (36x60x2202)



F09 UPRIGHT - W4L20079  
(x1) 1 7/16"x2 3/8"x85 11/16" (36x60x2177)



F10 UPRIGHT - W4L20080  
(x1) 1 7/16"x2 3/8"x85 11/16" (36x60x2177)



F11 WINDOW FRAME - W4L20087  
(x1) 1 7/16"x2 3/8"x20" (36x60x508)



F12 FAN FRAME - W4L20091  
(x1) 1 7/16"x2 3/8"x16 5/8" (36x60x422)



F13 FAN FRAME - W4L20092  
(x1) 1 7/16"x2 3/8"x16 5/8" (36x60x422)



F14 FAN FRAME - W4L20096  
(x1) 1 7/16"x2 3/8"x10 9/16" (36x60x268)



G01 BASE BOARD - W4L20031  
(x2) 15/16"x5 1/4"x67" (24x134x1702)



G02 BASE BOARD - W4L20045  
(x2) 15/16"x5 1/4"x45 11/16" (24x134x1160)



G03 BASE BOARD - W4L20050  
(x2) 15/16"x5 1/4"x17 7/8" (24x134x454)

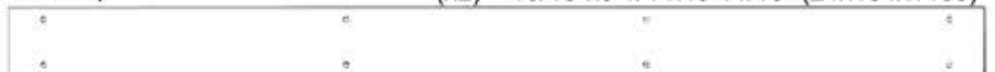

G04 BASE BOARD - W4L20076  
(x1) 15/16"x5 1/4"x72 3/4" (24x134x1848)

# OWNER'S MANUAL - PARTS IDENTIFICATION

## WOOD COMPONENTS (NOT TO SCALE)

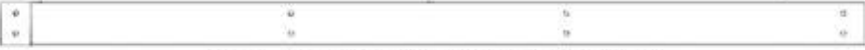

H01 RUNNING BOARD - W4L20029  
(x2) 15/16"x3 3/8"x67" (24x86x1702)



H02 RUNNING BOARD - W4L20043  
(x2) 15/16"x3 3/8"x45 11/16" (24x86x1160)



H03 RUNNING BOARD - W4L20047  
(x2) 15/16"x3 3/8"x17 7/8" (24x86x454)



H04 SHELF BOARD - W4L20067  
(x2) 15/16"x3 3/8"x68 1/4" (24x86x1734)



H05 RUNNING BOARD - W4L20078  
(x1) 15/16"x3 3/8"x72 3/4" (24x86x1848)



J01 PURLIN - W4L20105  
(x2) 15/16"x2 3/8"x67 15/16" (24x60x1725)



J02 PURLIN - W4L20106  
(x2) 15/16"x2 3/8"x46 9/16" (24x60x1183)



J03 PURLIN - W4L20108  
(x2) 15/16"x2 3/8"x67 15/16" (24x60x1725)



J04 PURLIN - W4L20107  
(x2) 15/16"x2 3/8"x46 9/16" (24x60x1183)



J05 RIDGE STIFFENER - W4L20112  
(x2) 15/16"x2 3/8"x69 3/16" (24x60x1757)



J06 RIDGE STIFFENER - W4L20113  
(x2) 15/16"x2 3/8"x43 9/16" (24x60x1107)



K01 PEAK TRIM - W4L20060  
(x2) 5/8"x5 1/4"x15 1/4" (16x134x388)



M01 TABLE TRIM - W4L20037  
(x1) 5/8"x3 3/8"x89 1/2" (16x86x2274)



M02 COVER BOARD - W4L20041  
(x14) 5/8"x3 3/8"x24 3/16" (16x86x614)



M03 TABLE TRIM - W4L20085  
(x1) 5/8"x3 3/8"x68 11/16" (16x86x1744)



N01 WINDOW TRIM - W4L20057  
(x4) 5/8"x2 3/8"x31 5/16" (16x60x796)



N02 WINDOW TRIM - W4L20054  
(x4) 5/8"x2 3/8"x13 3/16" (16x60x335)



N03 WINDOW TRIM - W4L20059  
(x4) 5/8"x2 3/8"x26" (16x60x660)



N04 PERGOLA PURLIN - W4L20071  
(x6) 5/8"x2 3/8"x71 1/4" (16x60x1810)



N05 WINDOW TRIM - W4L20086  
(x1) 5/8"x2 3/8"x19 3/8" (16x60x492)



N06 SLAT - W4L20089  
(x12) 5/8"x2 3/8"x25 3/8" (16x60x645)



N07 SLAT FRAME - W4L20094  
(x1) 5/8"x2 3/8"x53 7/8" (16x60x1368)



N08 FAN TRIM - W4L20097  
(x2) 5/8"x2 3/8"x10 9/16" (16x60x268)



N09 FAN TRIM - W4L20098  
(x1) 5/8"x2 3/8"x15 1/4" (16x60x388)



N10 SPIGOT BOARD - W4L20114  
(x1) 5/8"x2 3/8"x20 11/16" (16x60x526)

# OWNER'S MANUAL - PARTS IDENTIFICATION

## WOOD COMPONENTS (NOT TO SCALE)



O01 DOOR STOP - W4L20063  
(x2) 5/8"x1 5/16"x80 5/16" (16x34x2040)



P01 TABLE CLEAT - W4L20036  
(x3) 1 7/16"x1 7/16"x11 13/16" (36x36x300)



P02 WINDOW CAP - W4L20038  
(x10) 1 7/16"x1 7/16"x18 7/8" (36x36x480)



P03 WINDOW CAP - W4L20061  
(x2) 1 7/16"x1 7/16"x10 13/16" (36x36x274)



P04 TABLE CLEAT - W4L20084  
(x1) 1 7/16"x1 7/16"x64 13/16" (36x36x1646)



P05 WINDOW CAP - W4L20090  
(x2) 1 7/16"x1 7/16"x19 7/8" (36x36x505)



P06 TABLE CLEAT - W4L20095  
(x1) 1 7/16"x1 7/16"x87 3/8" (36x36x2220)



Q01 RIDGE BOARD - W4L20101  
(x2) 15/16"x4 7/16"x87 13/16" (24x112x2230)



Q02 RIDGE BOARD - W4L20102  
(x2) 15/16"x4 7/16"x23 3/4" (24x112x604)



Q03 FASCIA - W4L20109  
(x2) 15/16"x4 7/16"x47 1/16" (24x112x1196)



Q04 FASCIA - W4L20110  
(x2) 15/16"x4 7/16"x68 7/16" (24x112x1738)



V01 LATCH BLOCK - W4L20099  
(x1) 1 1/4"x1 1/4"x3" (32x32x76)



Y01 COVER BOARD - W4L20042  
(x4) 5/8"x4"x24 3/16" (16x102x614)

# OWNER'S MANUAL - PARTS IDENTIFICATION

## WOOD COMPONENTS (NOT TO SCALE)

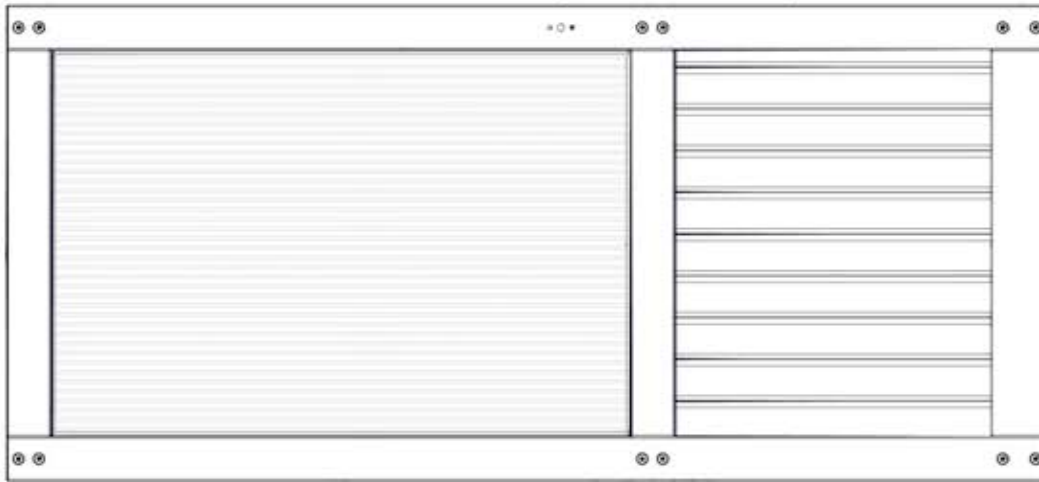

DA01 DOOR ASSEMBLY - W2A04072  
(x1) 1 7/8"x36 9/16"x80" (48x928x2032)

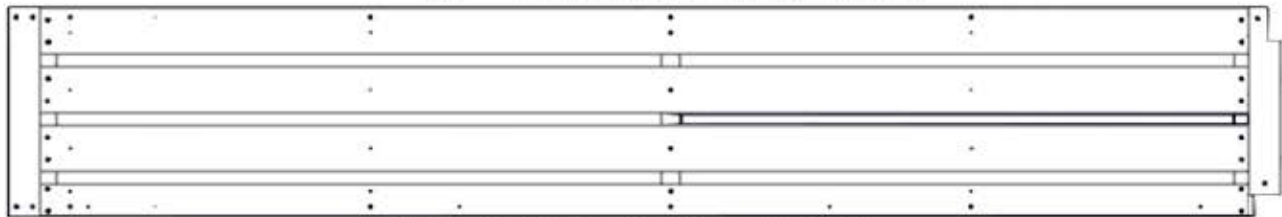

TB01 TABLE ASSEMBLY - W2A04325  
(x1) 2 1/16"x14 7/8"x89 1/2" (52x378x2274)

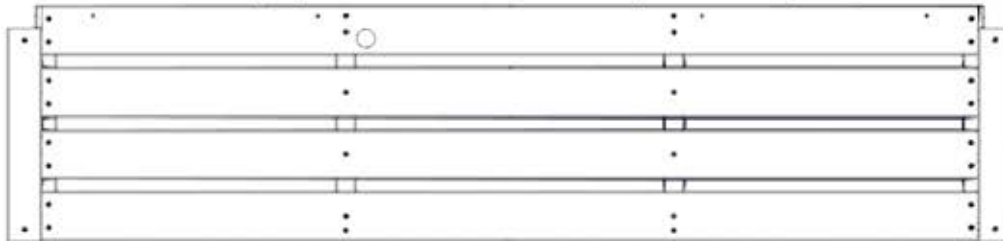

TB02 TABLE ASSEMBLY - W2A04331  
(x1) 2 1/16"x16 1/16"x68 11/16" (52x408x1744)



WA01 WINDOW ASSEMBLY - W2A04327  
(x2) 1 7/16"x15 11/16"x24 3/4" (36x398x629)

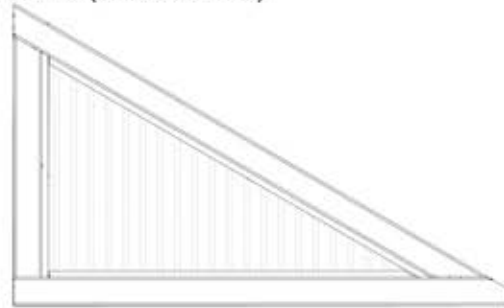

WA02 WINDOW ASSEMBLY - W2A04328  
(x2) 1 7/16"x15 11/16"x24 3/4" (36x398x629)



WA03 WINDOW ASSEMBLY - W2A04330  
(x1) 1 7/8"x19 5/8"x47 3/16" (48x498x1198)

# OWNER'S MANUAL - PARTS IDENTIFICATION

## WOOD COMPONENTS (NOT TO SCALE)

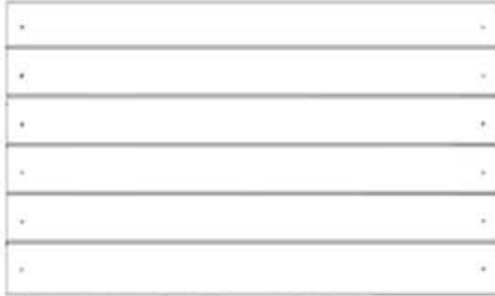

WP01 WALL PANEL - W2A04324  
(x8) 1 1/16"x18 7/8"x31 9/16" (27x480x802)

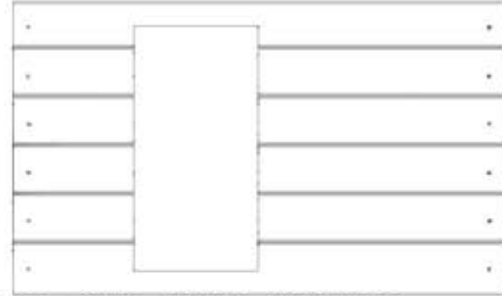

WP02 WALL PANEL - W2A04326  
(x1) 1 1/16"x18 7/8"x31 9/16" (27x480x802)



WP03 WALL PANEL - W2A04329  
(x2) 6 15/16"x10 7/8"x31 9/16" (177x276x802)

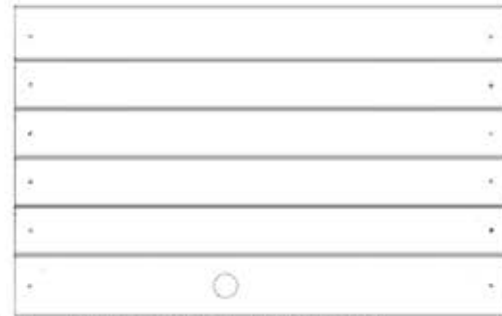

WP04 WALL PANEL - W2A04332  
(x1) 1 3/16"x19 15/16"x31 9/16" (30x507x802)

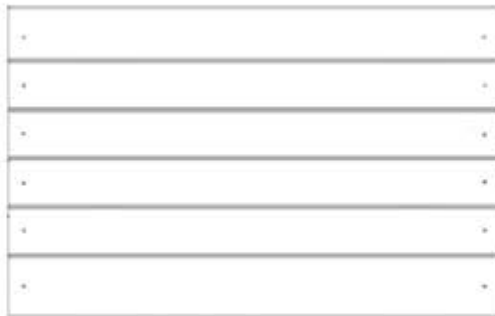

WP05 WALL PANEL - W2A04333  
(x2) 1 3/16"x19 15/16"x31 9/16" (30x507x802)

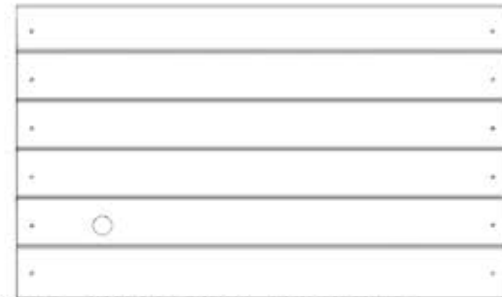

WP06 WALL PANEL - W2A04334  
(x1) 1 1/16"x18 7/8"x31 9/16" (27x480x802)

# OWNER'S MANUAL - PARTS IDENTIFICATION

## ACCESSORY COMPONENTS (NOT TO SCALE)

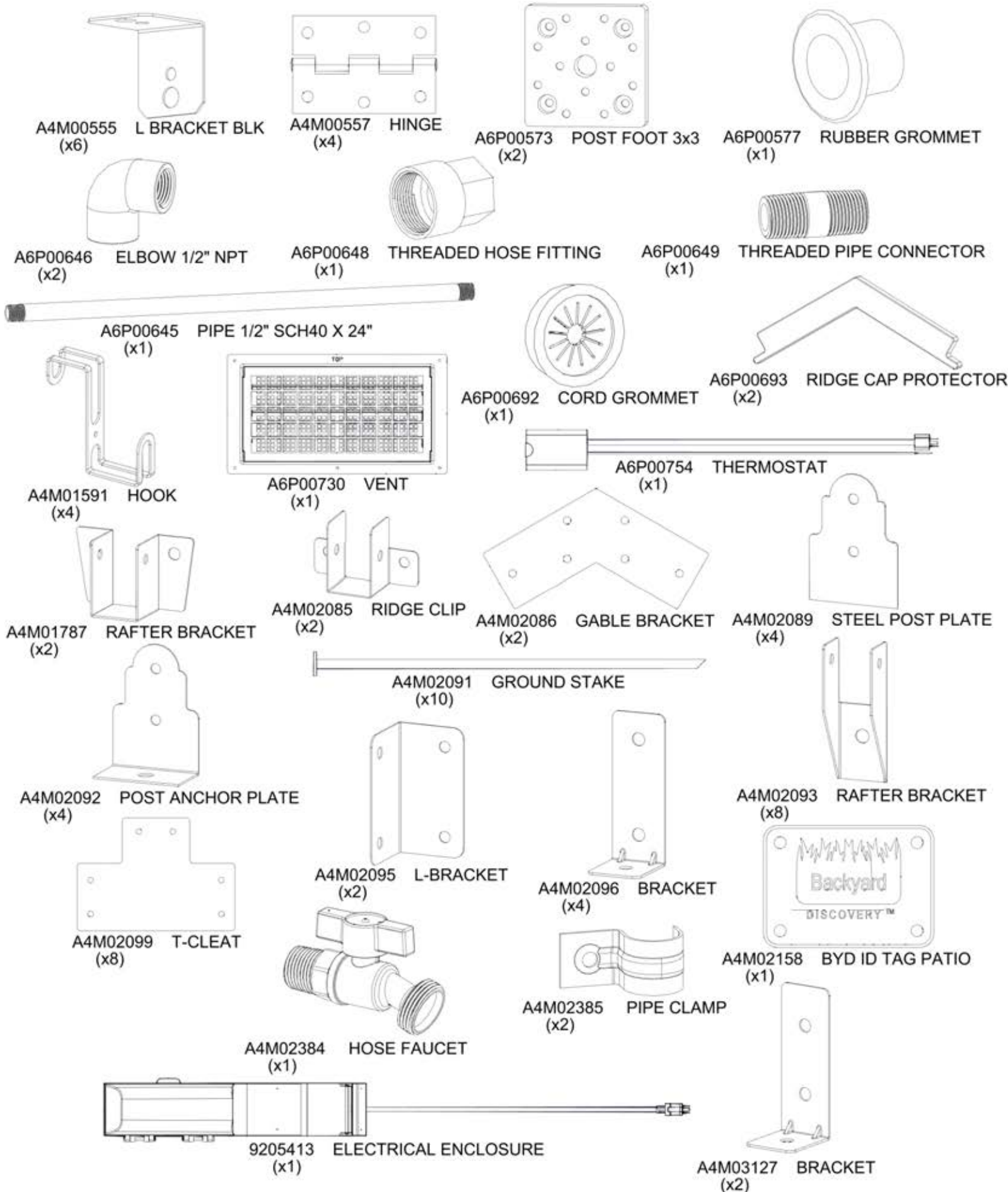

# OWNER'S MANUAL - PARTS IDENTIFICATION

ACCESSORY COMPONENTS (NOT TO SCALE)

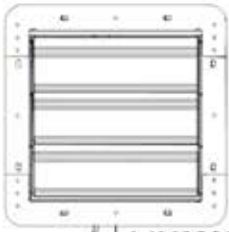

A4M02383 EXHAUST FAN  
(x1)



A4M02526 DOOR BRACKET  
(x1)

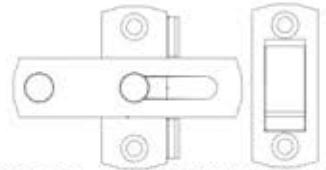

A4M02607 WINDOW LATCH LOCK  
(x1)

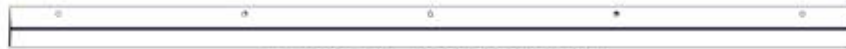

A4M02532 DOOR SWEEP  
(x1)



A4M02811 SHELF BRACKET  
(x4)



A4M02410 STORM DOOR HANDLE  
(x1)



A4M02411 DOOR PROTECTOR CHAIN  
(x1)

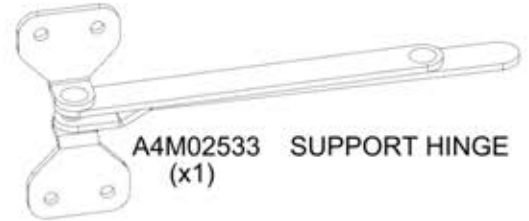

A4M02533 SUPPORT HINGE  
(x1)



A4M03137 RIDGE CAP  
(x2)



A4M03131 RIDGE CAP SPLICE  
(x1)



A4M03136 SPLICE COVER  
(x8)



A4M03135 TRIM  
(x4)



A4M03134 SOFFIT  
(x2)



A4M03133 SOFFIT  
(x2)



A4M03129 SOFFIT SPLICE  
(x2)



A4M03130 EDGE TRIM SPLICE  
(x2)

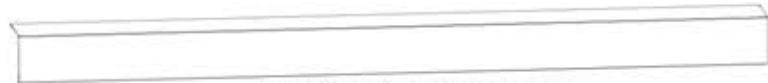

A4M03132 EDGE TRIM  
(x4)

# OWNER'S MANUAL - PARTS IDENTIFICATION

## ACCESSORY COMPONENTS (NOT TO SCALE)



A6P00870 POLY SHEET  
(x10)



A6P00914 POLY SHEET  
(x2)



A6P00916 POLY SHEET  
(x1)



A6P00924 POLY SHEET  
(x2)



A6P00931 POLY SHEET  
(x4)



A6P00932 POLY SHEET  
(x6)



A6P00929 POLY SHEET SPLICE  
(x8)



A6P00871 POLY CHANNEL  
(x20)



A6P00872 POLY CHANNEL  
(x28)



A6P00906 POLY CHANNEL  
(x8)



A6P00907 POLY CHANNEL  
(x12)



A6P00915 POLY CHANNEL  
(x4)



A6P00917 POLY CHANNEL  
(x2)



A6P00923 POLY CHANNEL  
(x2)



A6P00925 POLY CHANNEL  
(x4)



A6P00930 POLY CHANNEL  
(x4)



A6P00809 PLUMBERS TAPE  
(x1)



A6P00690 DUST SEAL TAPE  
(x1)



A6P00813 DOUBLE SIDED TAPE  
(x1)

# OWNER'S MANUAL - PARTS IDENTIFICATION

## HARDWARE COMPONENTS

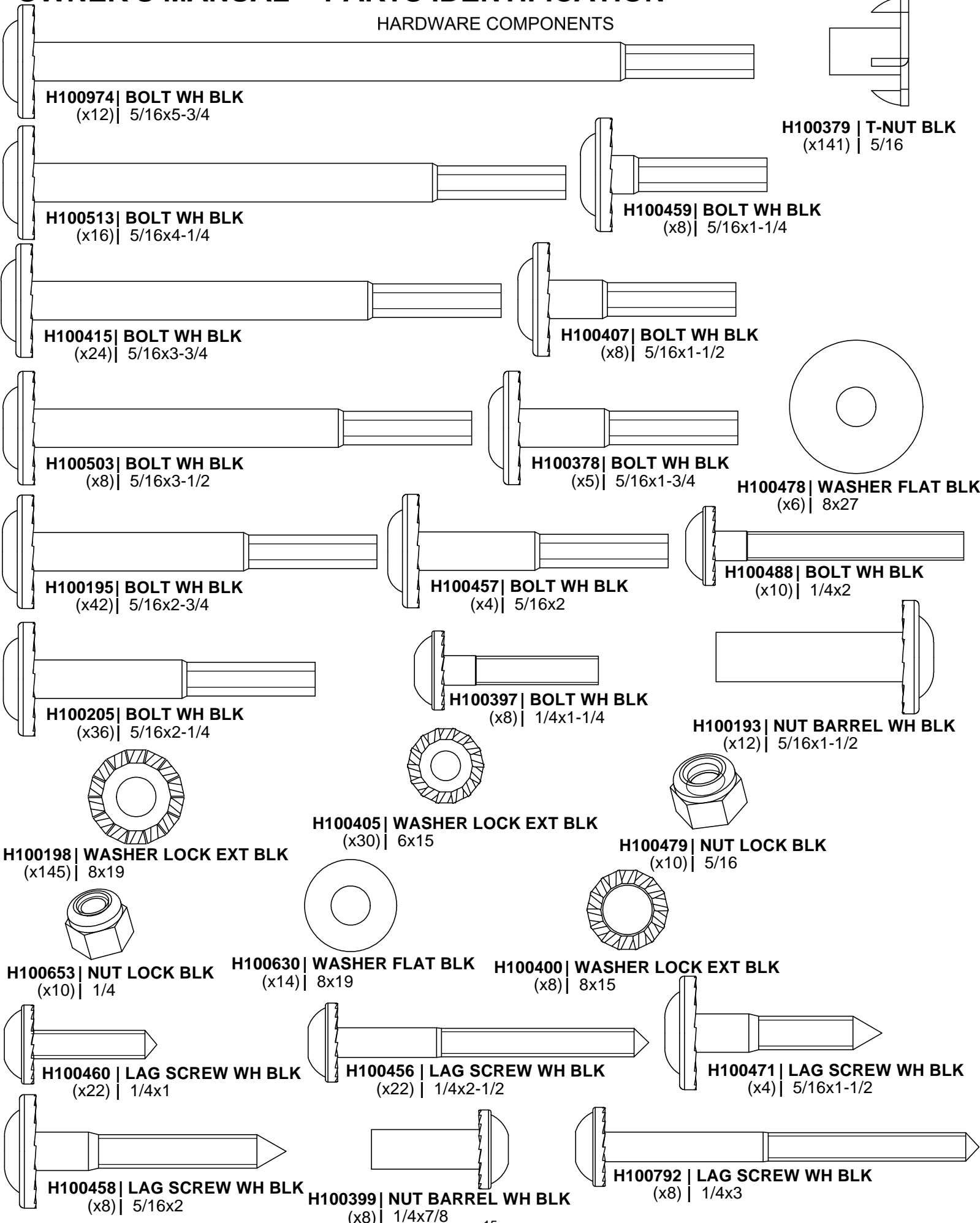

# OWNER'S MANUAL - PARTS IDENTIFICATION

## HARDWARE COMPONENTS

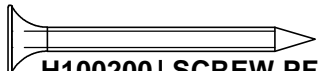

**H100200 | SCREW PFH BLK**  
(x108) | 8x1-1/2



**H100201 | SCREW PFH BLK**  
(x31) | 8x2-1/2

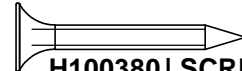

**H100380 | SCREW PFH BLK**  
(x52) | 8x1-1/8

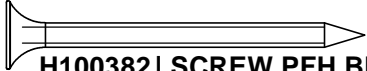

**H100382 | SCREW PFH BLK**  
(x252) | 8x1-3/4

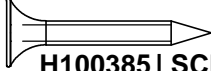

**H100385 | SCREW PFH BLK**  
(x87) | 8x1

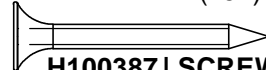

**H100387 | SCREW PFH BLK**  
(x36) | 8x1-1/4



**H100391 | SCREW PFH BLK**  
(x169) | 8x2

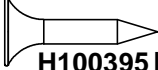

**H100395 | SCREW PFH BLK**  
(x32) | 8x3/4

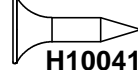

**H100411 | SCREW PFH BLK**  
(x3) | 8x5/8



**H100483 | SCREW PFH BLK**  
(x20) | 8x2-1/4



**H101109 | SCREW PFH BLK**  
(x10) | 8x3-1/2



**H100202 | SCREW PWH BLK**  
(x9) | 8x5/8

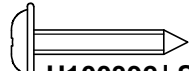

**H100392 | SCREW PWH BLK**  
(x18) | 8x3/4



**H100536 | SCREW PWH BLK**  
(x6) | 8x1-1/4

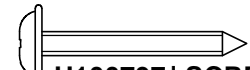

**H100797 | SCREW PWH BLK**  
(x4) | 8x1

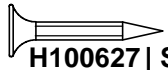

**H100627 | SCREW PFH BLK**  
(x4) | 6x3/4



**H100362 | SCREW PFH BLK**  
(x8) | 8x3



**H100777 | SCREW PFH BLK**  
(x4) | 10x 3-1/2

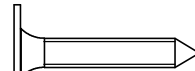

**H101207 | SCREW PWH BLK**  
(x8) | 8x7/8

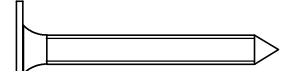

**H101203 | SCREW PWH BLK**  
(x32) | 8x1 1/4

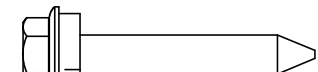

**H101206 | SCREW WOODGRIP**  
(x14) | 10x1-1/4

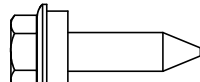

**H101117 | SCREW WOODGRIP**  
(x28) | 10x3/4

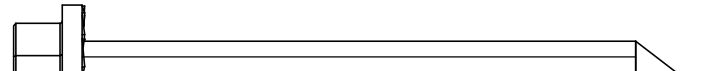

**H101165 | CONCRETE ANCHOR 3/8"x3" BLK**  
(x10) | 3/8x3

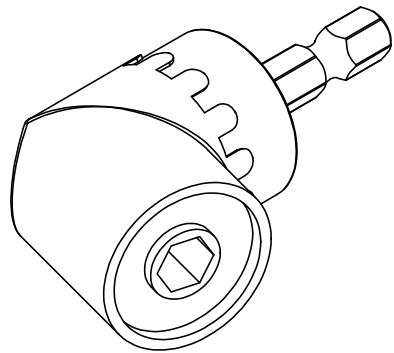

**H101114 | RIGHT HAND  
DRILL ADAPTER**  
(x1)

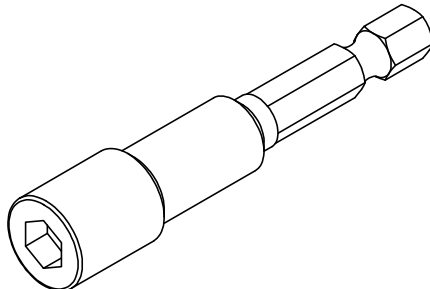

**H101106 | SOCKET DRIVER**  
(x1)

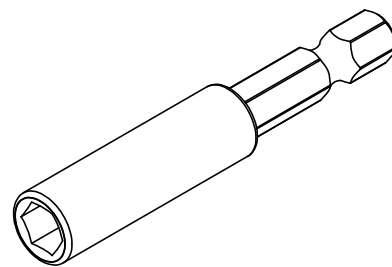

**H101100 | MAGNETIC DRIVER**  
(x1)

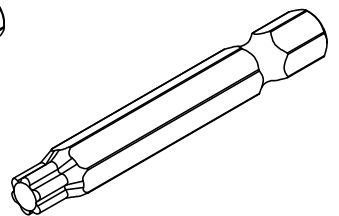

**H100147 | TORX BIT**  
(x1) | T-30

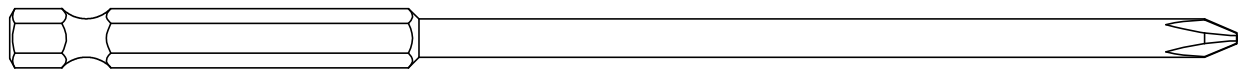

**H101261 | PHILLIPS EXTENSION BIT**  
(x1)

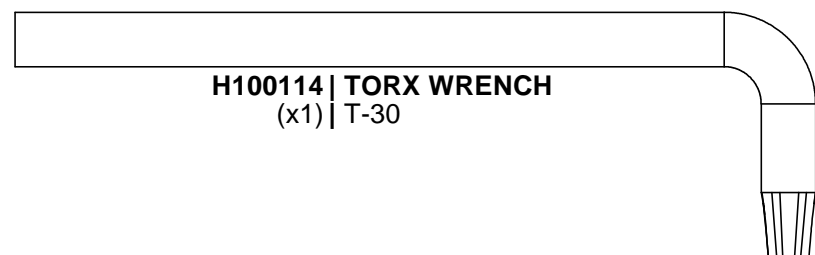

**H100114 | TORX WRENCH**  
(x1) | T-30

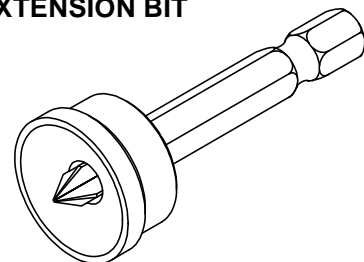

**H100764 | SCREW SETTER**  
(x1)

# PRE-ASSEMBLY STEP 1 - SORTING PARTS

It is critical for ease of assembly that you take the time to sort and organize the wood and hardware.

---

## WOOD PARTS:

- Organize wood parts by the three-digit, alpha-numeric number stamped on each board (ex. P01).
- If there are multiple boards with the same stamped number, stack those pieces together.
- Stamps can be found on the flat surface of the boards or on the end of the boards.
- Allow yourself plenty of room - the wood pieces can take up a significant amount of space.

**NOTE: CARTONS ARE NOT ORGANIZED BY BOARD NUMBER.**



## HARDWARE PARTS:

- We recommend that you have a separate table to organize the hardware.
- Hardware bags are printed with a seven-digit, alpha-numeric part number.
- You can organize your hardware by part number or group by hardware type (i.e. bolts, nuts, etc.).
- During assembly you only need to reference the last four digits of the number.

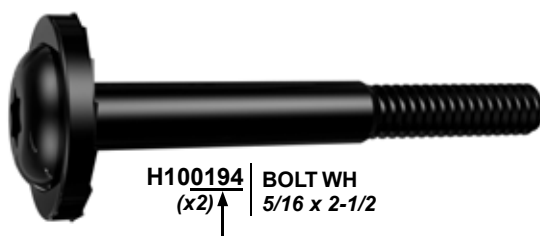

# PRE-ASSEMBLY STEP 2 - TOOLS REQUIRED



Cordless Drill  
or Electric Drill



Drill  
Attachments:  
Phillips Head

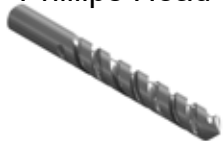

1/8", 3/16", 3/8" &  
7/16" Drill Bits



Phillips Screw Driver



Open End  
Wrenches 1/2"  
& 9/16"



3/8" Drive Ratchet, 1/2" &  
7/16" STD Sockets 1/2" & 7/16"  
Deep Sockets



Claw Hammer



Rubber Mallet  
- Optional



Tape Measure

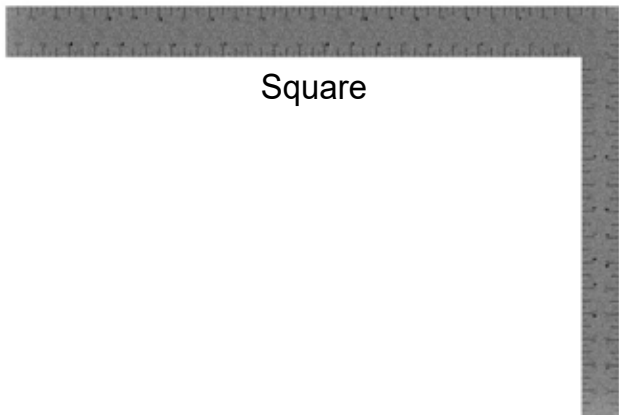

Square



Level 24"

# PRE-ASSEMBLY STEP 3 - CHOOSE YOUR ASSEMBLY METHOD

There are several types of assembly instructions available to you.

1. Printed Assembly Manual included with your set
2. BILT APP - 3D interactive instructions
3. Combination of the Printed Manual and BILT APP (Note: Step numbers can differ between the two methods)

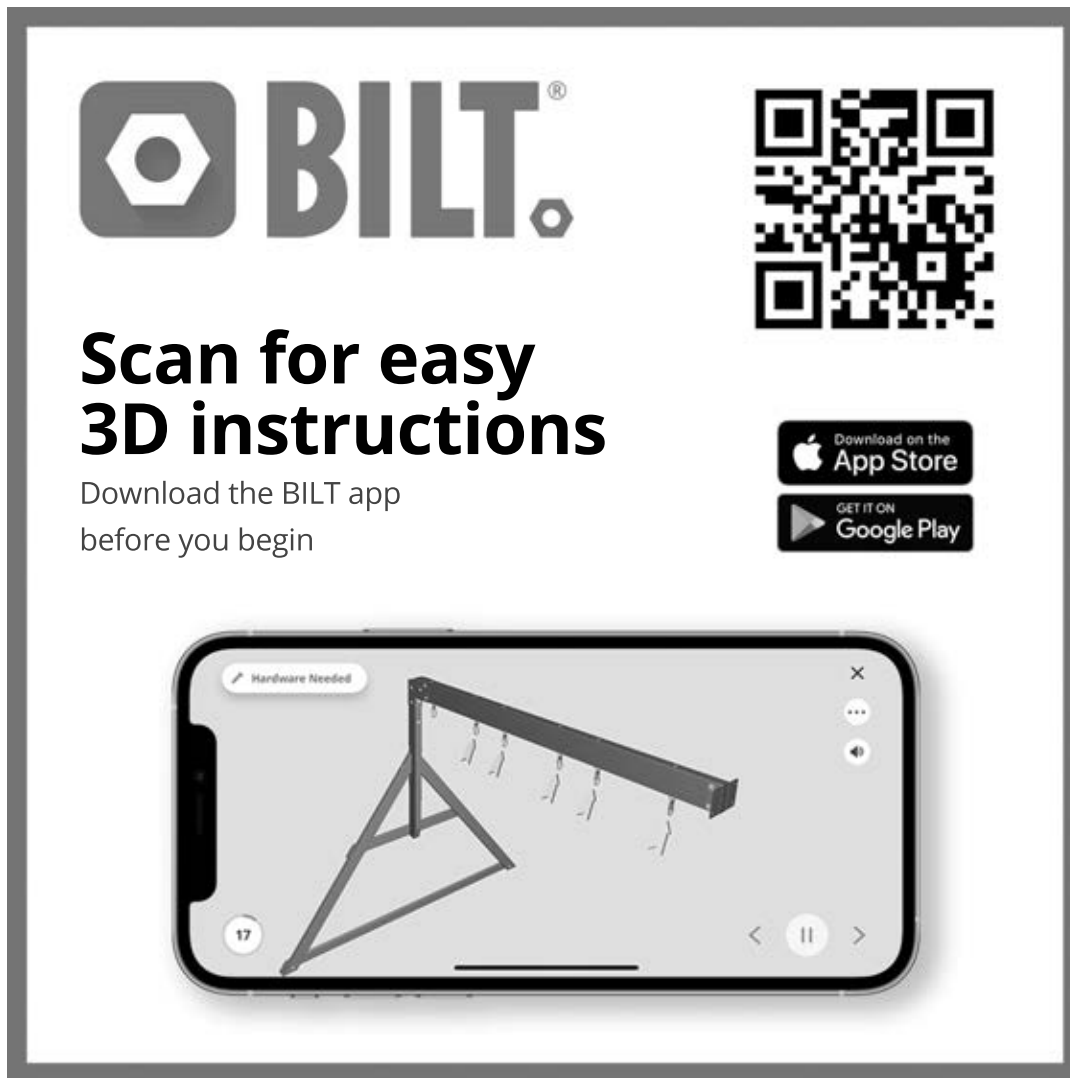

The graphic features the BILT logo (a hexagon with a bolt head inside) and the text "BILT.®" in a bold, sans-serif font. To the right is a large QR code. Below the logo, the text "Scan for easy 3D instructions" is written in a large, bold font. Underneath that, it says "Download the BILT app before you begin". To the right of this text are two buttons: "Download on the App Store" and "GET IT ON Google Play". At the bottom, a smartphone screen displays a 3D assembly instruction for step 17, showing a metal frame with a horizontal bar and several bolts. The screen has a "Hardware Needed" label at the top left, a close button (X) at the top right, and navigation arrows at the bottom.

# POLYCARBONATE SHEETING INFORMATION - IMPORTANT!

**The Polycarbonate Sheeting has UV protection on ONE (1) SIDE.**

**CRITICAL to install with the UV protection facing the OUTSIDE**

- Wear safety gloves to protect against any sharp edges during handling or install.
- Do NOT use knife or sharp object to remove protective film as it may result in damage to polycarbonate sheeting
- Leave film on during install to ensure UV side is facing outside.
- Peel protective film back from edges approximately 2" (5cm) during installation.
- Remove film completely after installation.

NOTE: Do not store polycarbonate sheeting with film outside in direct sunlight or rain. It may make removal of film more difficult.

# STEP 4 - BACK WALL ASSEMBLY

QTY	PART NUMBER	DESCRIPTION
8	H100198	WASHER LOCK EXT 8x19
4	H100379	TNUT-5/16" BLK
4	H100415	BOLT WH 5/16x3 3/4 BLK
4	H100458	LAG SCREW WH 5/16x2 BLK

G04 BASE BOARD - W4L20076  
(x1) 15/16"X5 1/4"X72 3/4" (24x134x1848)

B07 POST - W4L20075  
(x1) 3"x3"x88 3/4" (76x76x2254)

H05 RUNNING BOARD - W4L20078  
(x1) 15/16"x3 3/8"x72 3/4" (24x86x1848)

B08 POST - W4L20077  
(x1) 3"x3"x88 3/4" (76x76x2254)

- THE USE OF SAWHORSES IS RECOMMENDED DURING THE ASSEMBLY OF ALL WALL ASSEMBLIES.  
- INSERT T-NUTS FIRST.

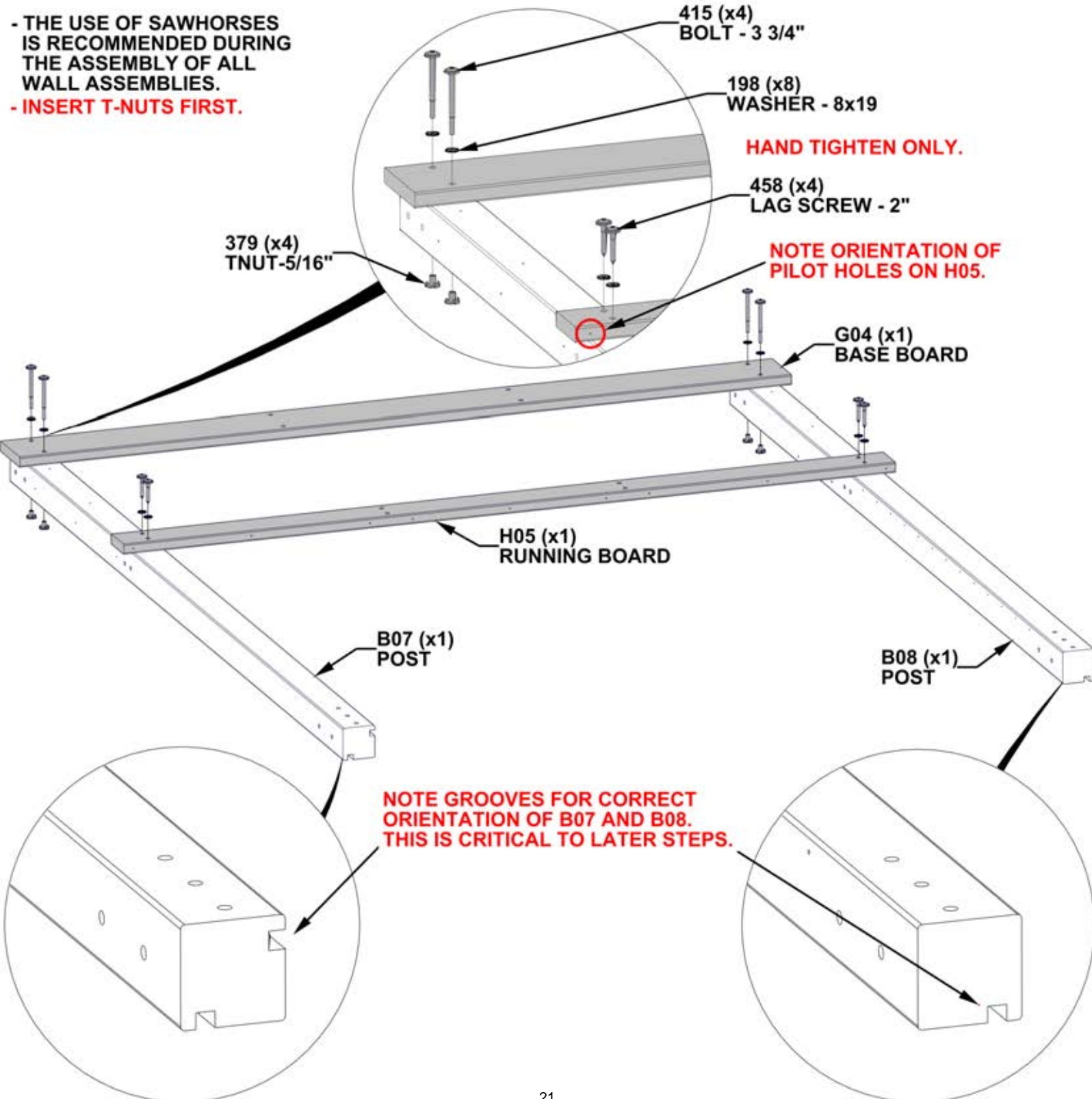

# STEP 5 - BACK WALL ASSEMBLY

QTY	PART NUMBER	DESCRIPTION
4	H100193	NUT BARREL WH 5/16 X 1 1/2 BLK
8	H100198	WASHER LOCK EXT 8x19
4	H100205	BOLT WH 5/16x2 1/4 BLK
4	H100379	TNUT-5/16" BLK
4	H100407	BOLT WH 5/16x1 1/2 BLK

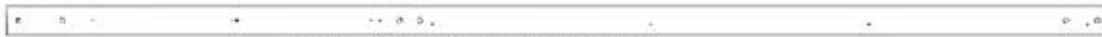

F09 UPRIGHT - W4L20079  
(x1) 1 7/16"x2 3/8"x85 11/16" (36x60x2177)



F10 UPRIGHT - W4L20080  
(x1) 1 7/16"x2 3/8"x85 11/16" (36x60x2177)



**- INSERT T-NUTS FIRST.**

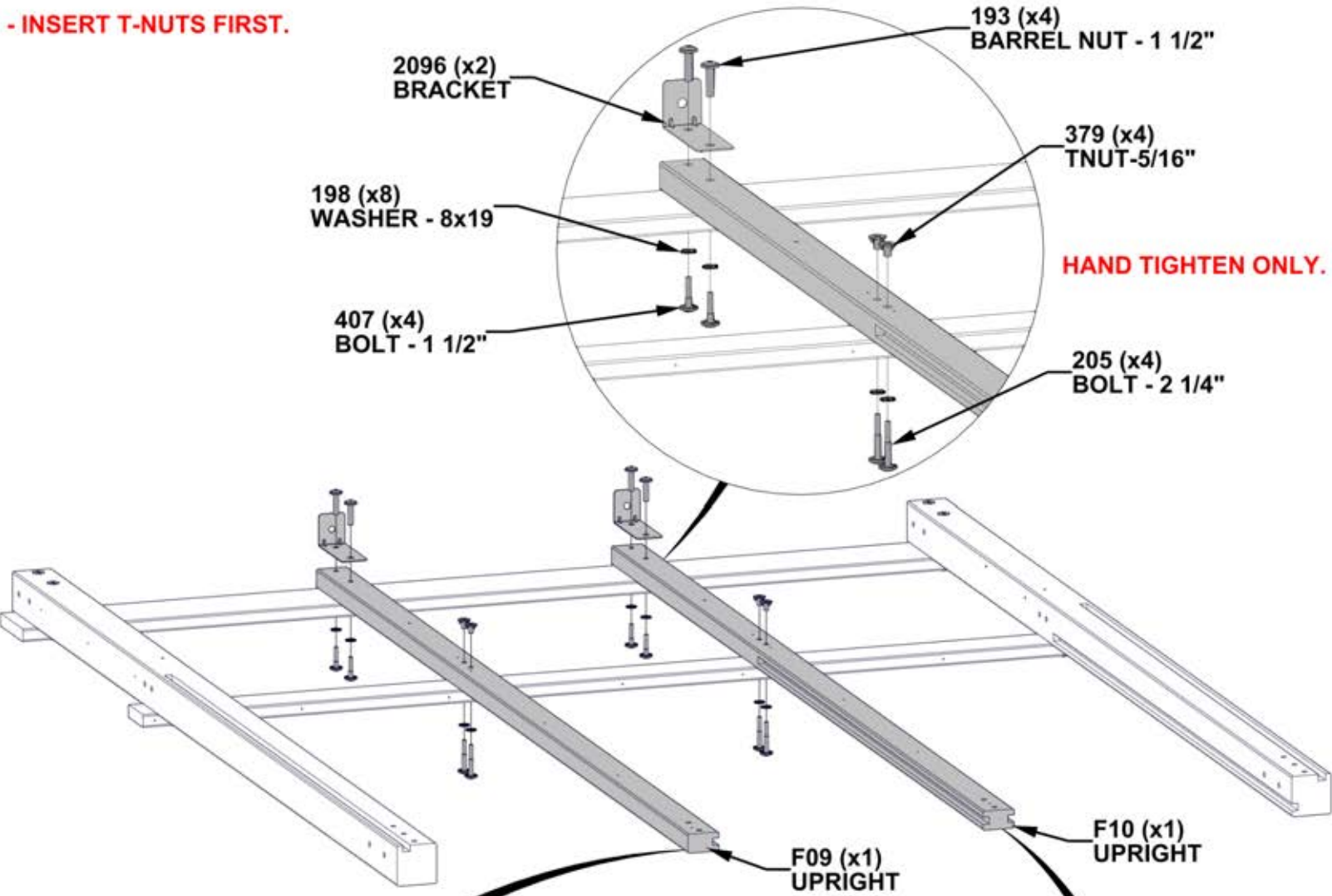

**NOTE LOCATION OF GROOVES AND PILOT HOLES FOR CORRECT ORIENTATION. THIS IS CRITICAL FOR LATER STEPS.**

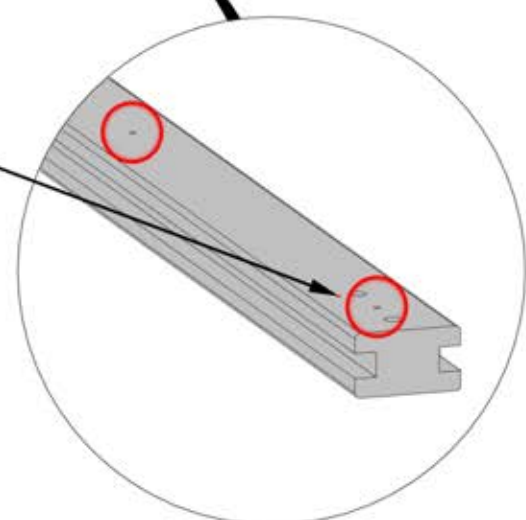
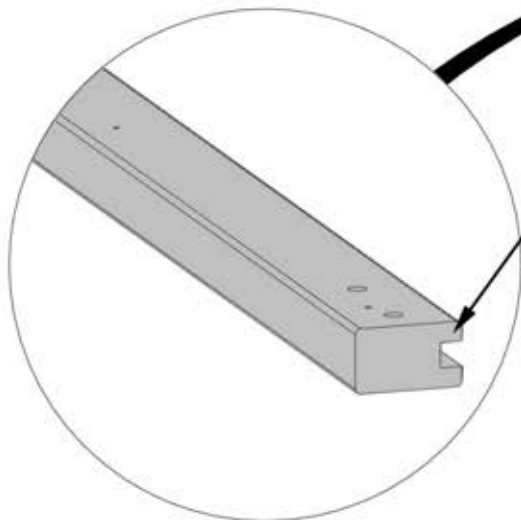

# STEP 6 - BACK WALL ASSEMBLY

QTY	PART NUMBER	DESCRIPTION
4	H100195	BOLT WH 5/16x2 3/4 BLK
8	H100198	WASHER LOCK EXT 8x19
8	H100379	TNUT-5/16" BLK
4	H100974	BOLT WH 5/16x5 3/4 BLK

D06 END TRIM - W4L20062  
(x2) 1 7/16"x134x219 (36x134x219)



D09 HEADER - W4L20083  
(x1) 1 7/16"x5 1/4"x73 11/16" (36x134x1872)

**- INSERT T-NUTS FIRST.**

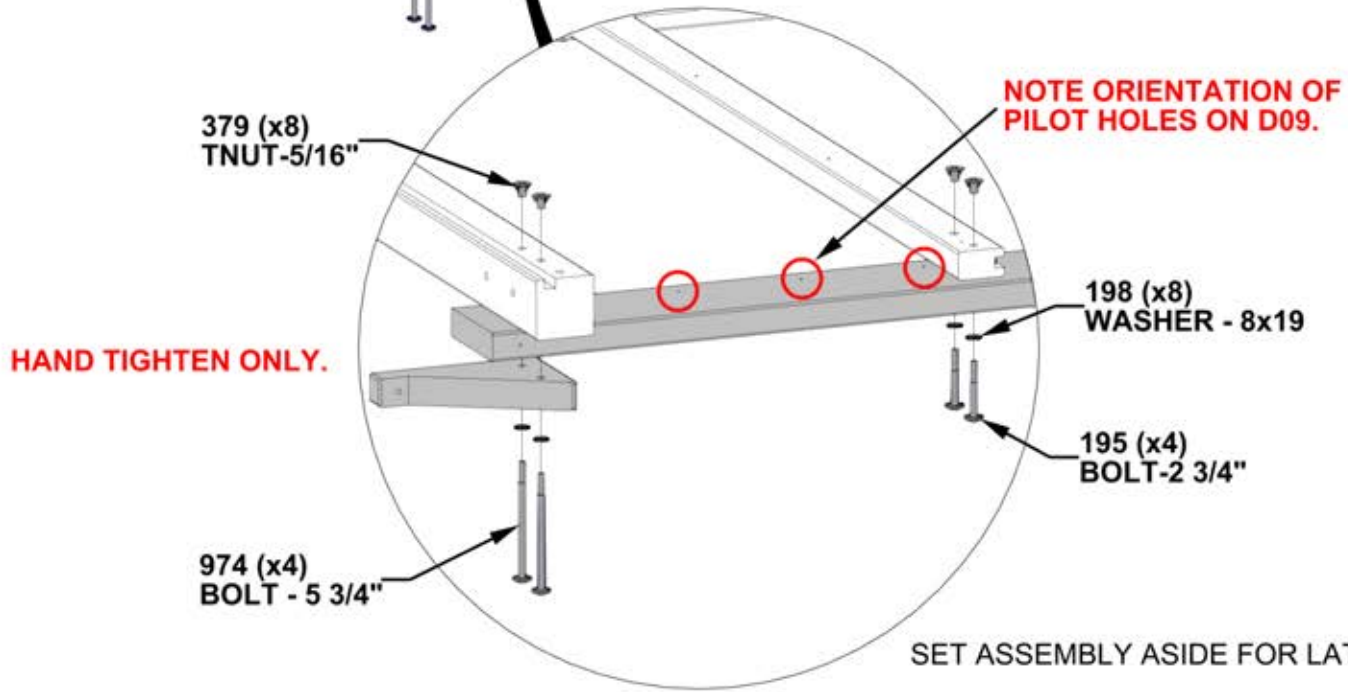
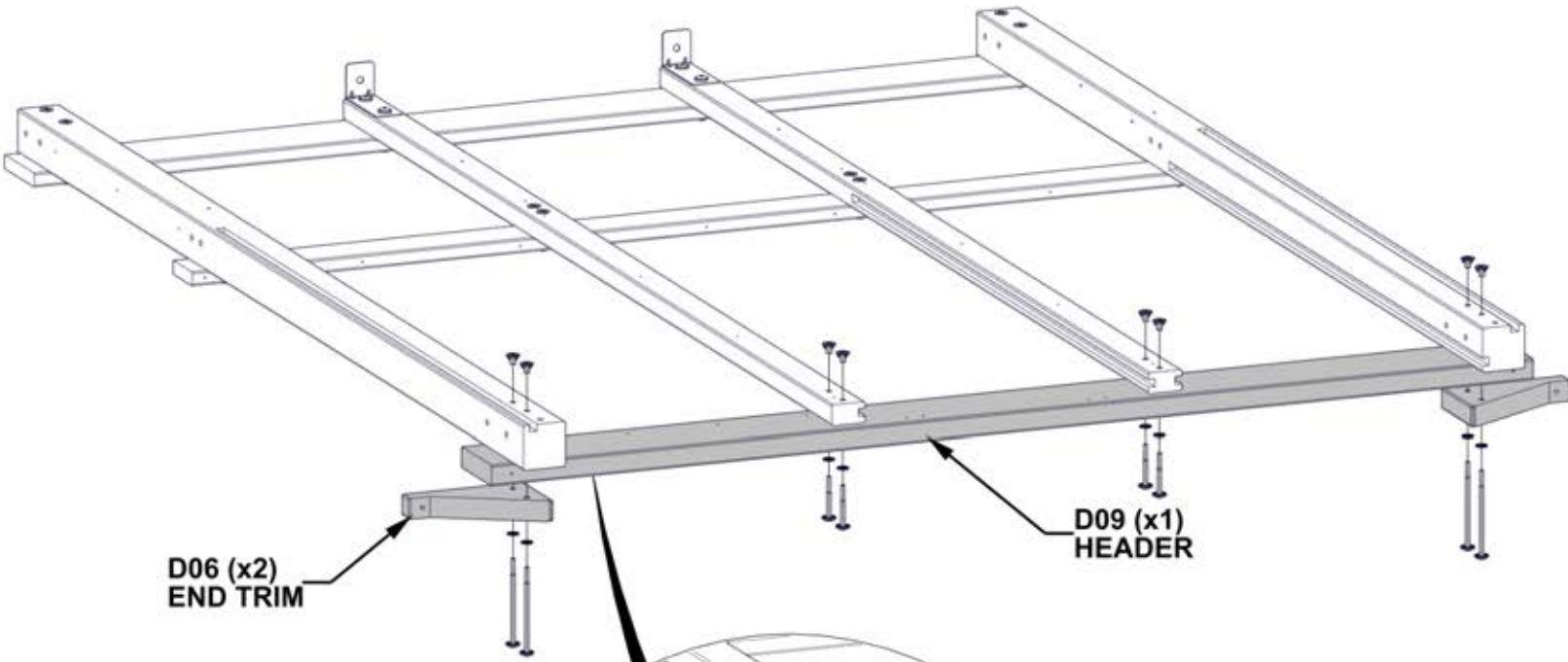

# STEP 7A - SIDE WALL ASSEMBLY

QTY	PART NUMBER	DESCRIPTION
1	H100195	BOLT WH 5/16x2 3/4 BLK
5	H100198	WASHER LOCK EXT 8x19
4	H100205	BOLT WH 5/16x2 1/4 BLK
5	H100379	TNUT-5/16" BLK

D02 HEADER - W4L20044  
(x1) 1 7/16"x5 1/4"x45 11/16" (36x134x1160)

F01 UPRIGHT - W4L20030  
(x1) 1 7/16"2 3/8"x86 11/16" (36x60x2202)

H02 RUNNING BOARD - W4L20043  
(x1) 15/16"x3 3/8"x45 11/16" (24x86x1160)

G02 BASE BOARD - W4L20045  
(x1) 15/16"x5 1/4"x45 11/16" (24x134x1160)

- INSERT T-NUTS FIRST.  
- HAND TIGHTEN ONLY.

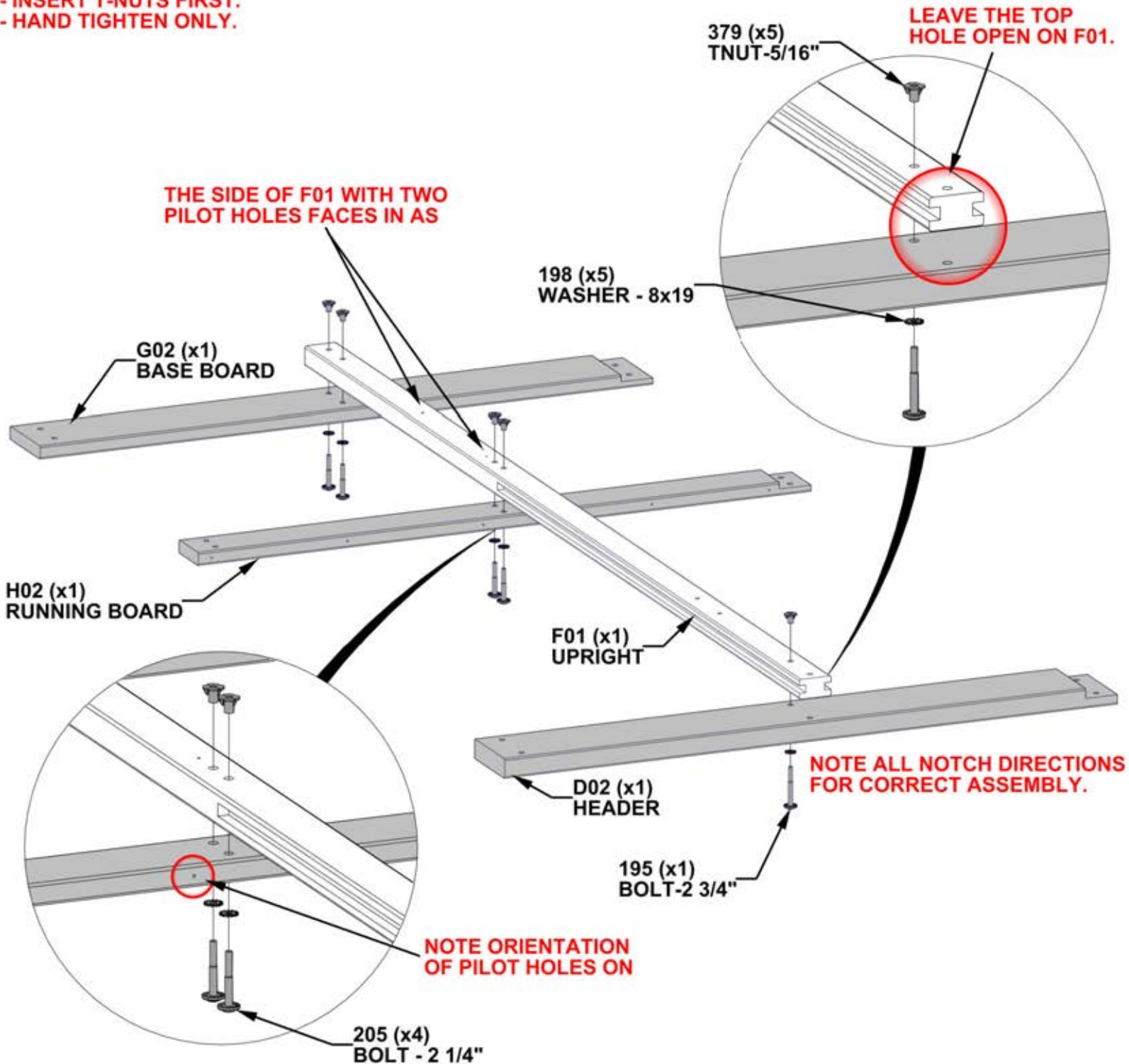

# STEP 7B - SIDE WALL ASSEMBLY

QTY	PART NUMBER	DESCRIPTION
2	H100195	BOLT WH 5/16x2 3/4 BLK
10	H100198	WASHER LOCK EXT 8x19
8	H100205	BOLT WH 5/16x2 1/4 BLK
10	H100379	TNUT-5/16" BLK

D01 HEADER - W4L20035  
(x1) 1 7/16"x5 1/4"x67" (36x134x1702)

F01 UPRIGHT - W4L20030  
(x2) 1 7/16"2 3/8"x86 11/16" (36x60x2202)

H01 RUNNING BOARD - W4L20029  
(x1) 15/16"x3 3/8"x67" (24x86x1702)

G01 BASE BOARD - W4L20031  
(x1) 15/16"x5 1/4"x67" (24x134x1702)

- INSERT T-NUTS FIRST.  
- HAND TIGHTEN ONLY.

LEAVE THE TOP HOLES OPEN ON F01 BOARDS.

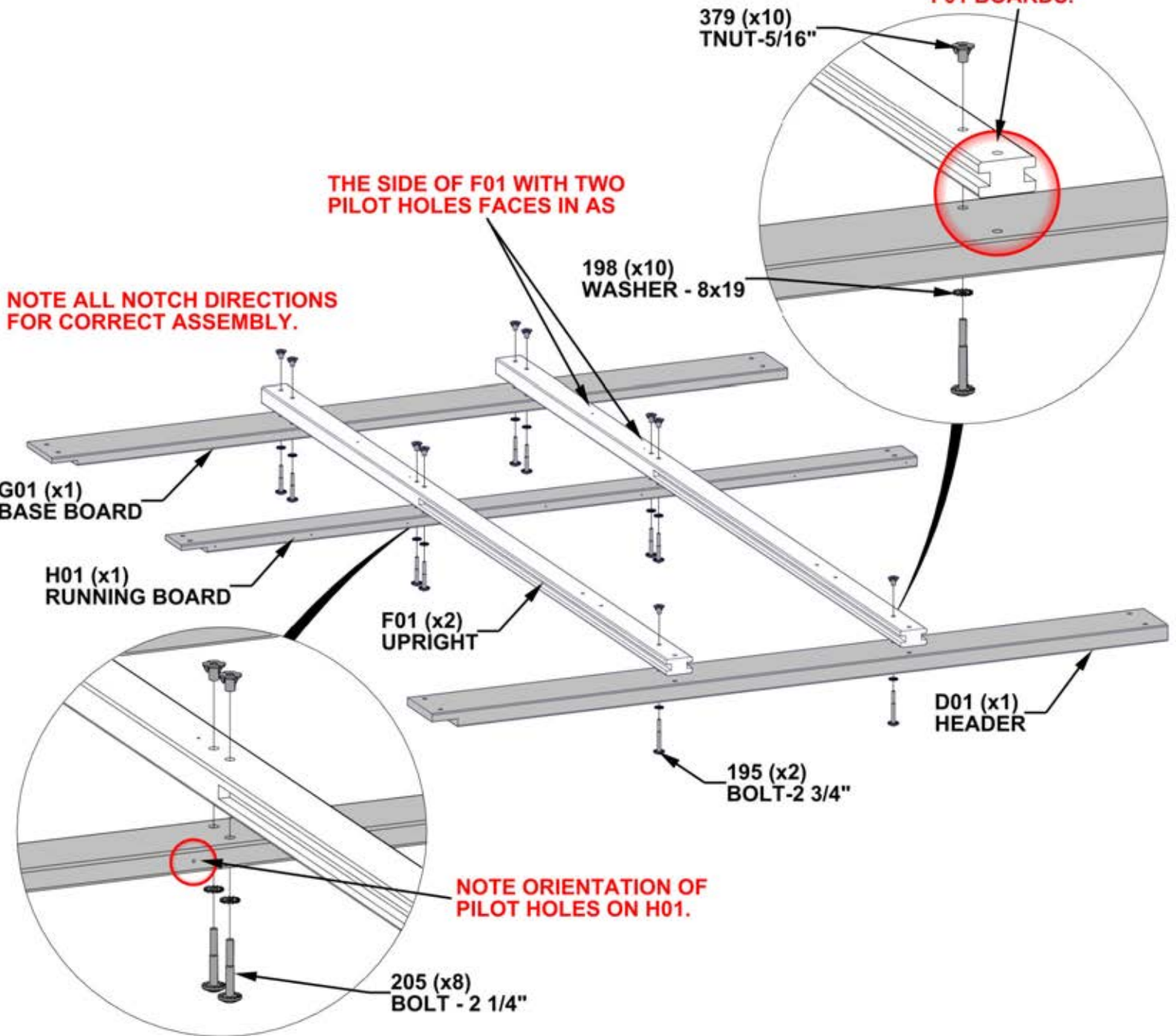

# STEP 7C - SIDE WALL ASSEMBLY

QTY	PART NUMBER	DESCRIPTION
2	H100193	NUT BARREL WH 5/16 X 1 1/2 BLK
1	H100195	BOLT WH 5/16x2 3/4 BLK
5	H100198	WASHER LOCK EXT 8x19
2	H100205	BOLT WH 5/16x2 1/4 BLK
3	H100379	TNUT-5/16" BLK
2	H100407	BOLT WH 5/16x1 1/2 BLK

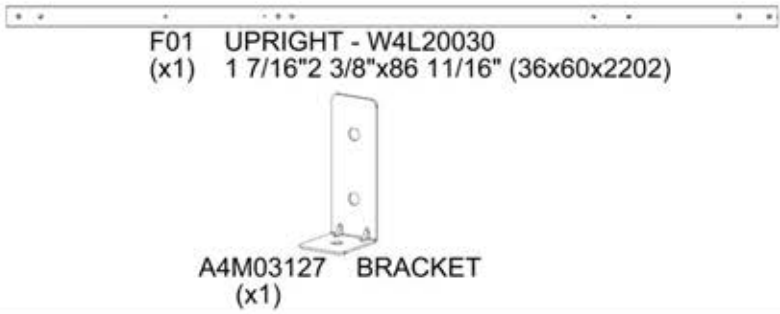

**- INSERT T-NUTS FIRST.**

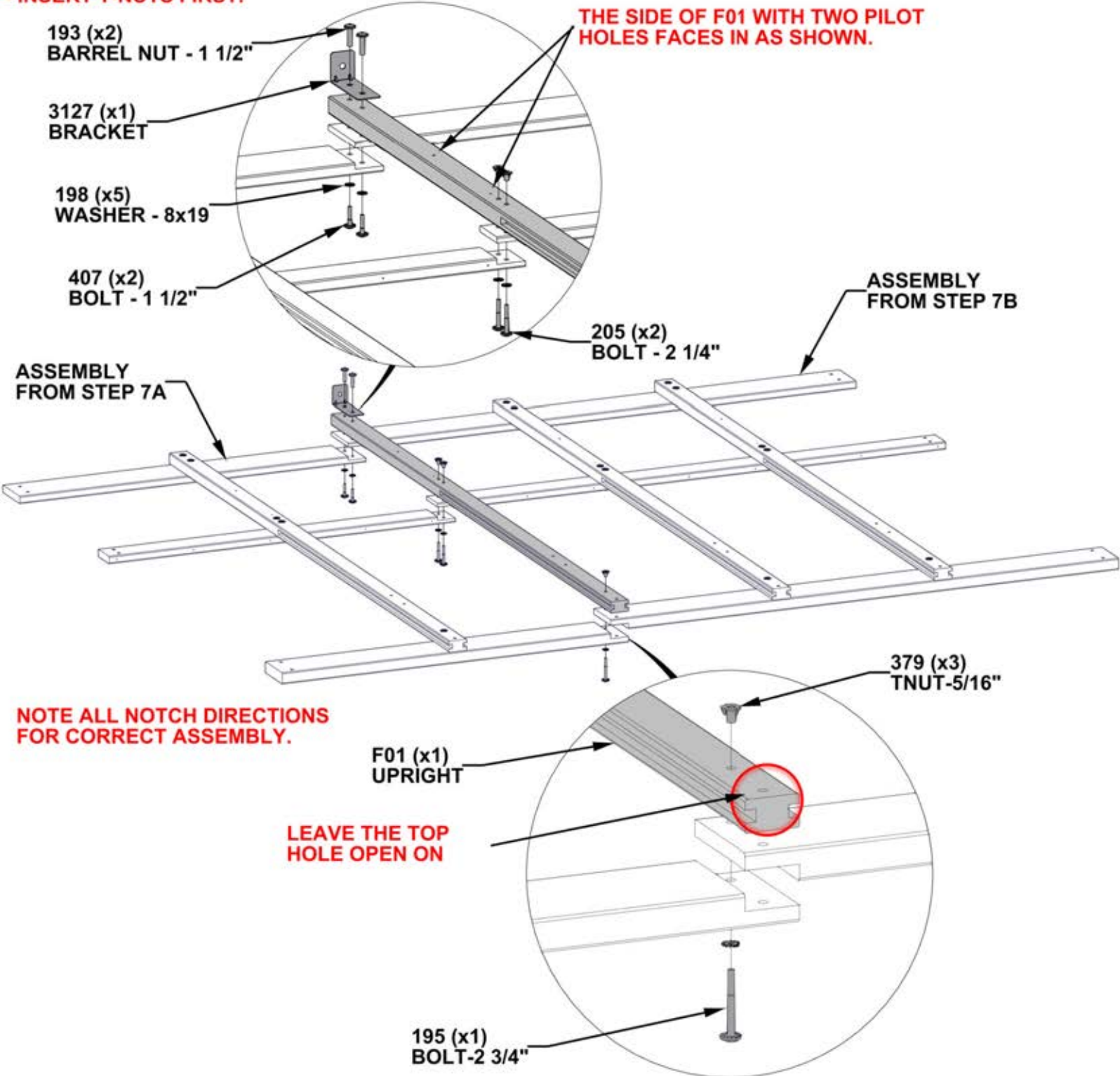

# STEP 8 - GREENHOUSE ASSEMBLY

QTY	PART NUMBER	DESCRIPTION
6	H100198	WASHER LOCK EXT 8x19
6	H100379	TNUT-5/16" BLK
4	H100415	BOLT WH 5/16x3 3/4 BLK
2	H100513	BOLT WH 5/16x4 1/4 BLK

**- INSERT T-NUTS FIRST.**

**STAND UP THE SIDE AND BACK ASSEMBLIES AND BOLT TOGETHER AS SHOWN.**

**HAND TIGHTEN ONLY.**

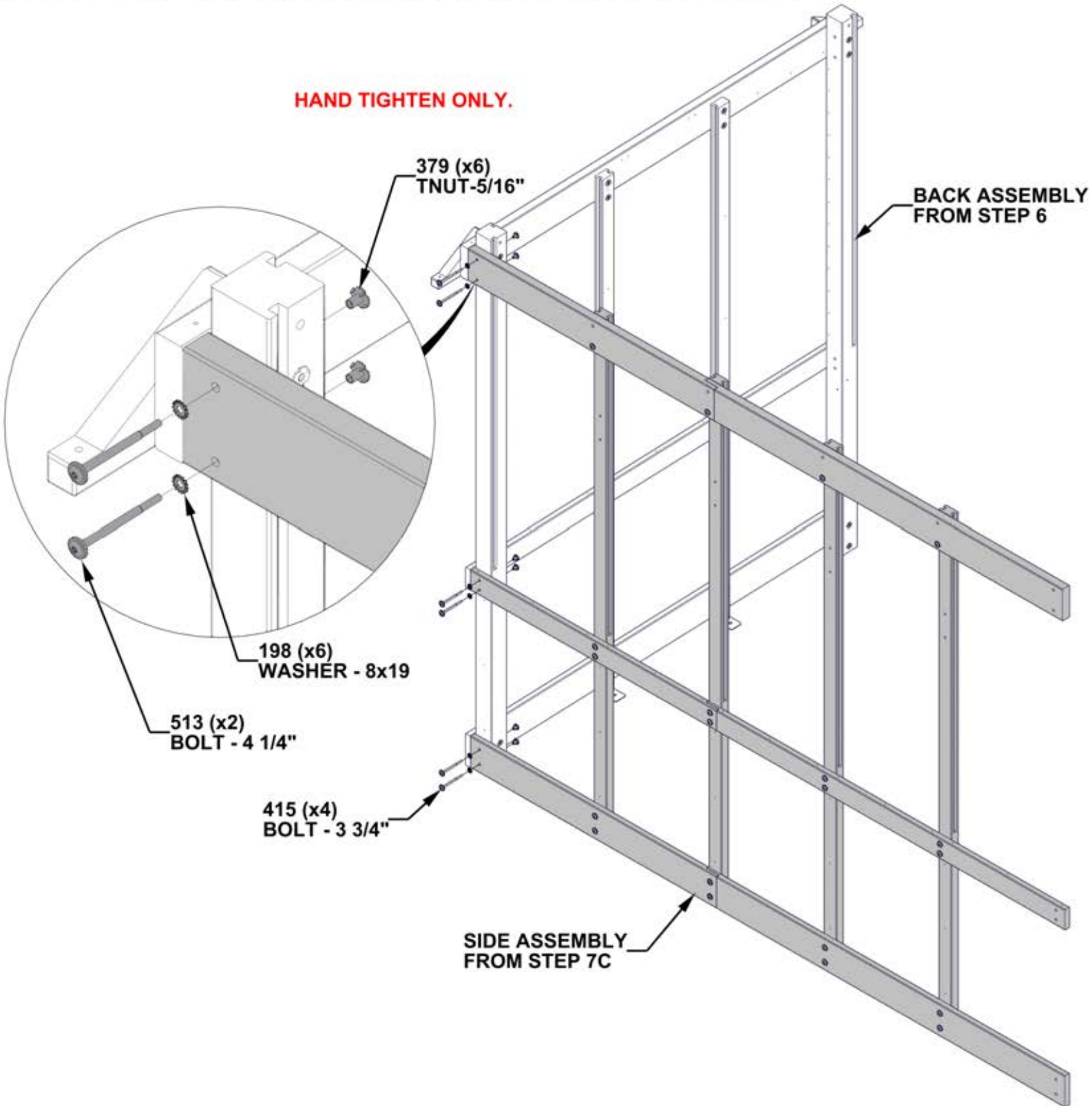

# STEP 9A - SIDE WALL ASSEMBLY

QTY	PART NUMBER	DESCRIPTION
1	H100195	BOLT WH 5/16x2 3/4 BLK
5	H100198	WASHER LOCK EXT 8x19
4	H100205	BOLT WH 5/16x2 1/4 BLK
5	H100379	TNUT-5/16" BLK

D02 HEADER - W4L20044  
(x1) 1 7/16"x5 1/4"x45 11/16" (36x134x1160)

F08 UPRIGHT - W4L20066  
(x1) 1 7/16"2 3/8"x86 11/16" (36x60x2202)

H02 RUNNING BOARD - W4L20043  
(x1) 15/16"x3 3/8"x45 11/16" (24x86x1160)

G02 BASE BOARD - W4L20045  
(x1) 15/16"x5 1/4"x45 11/16" (24x134x1160)

**- INSERT T-NUTS FIRST.**

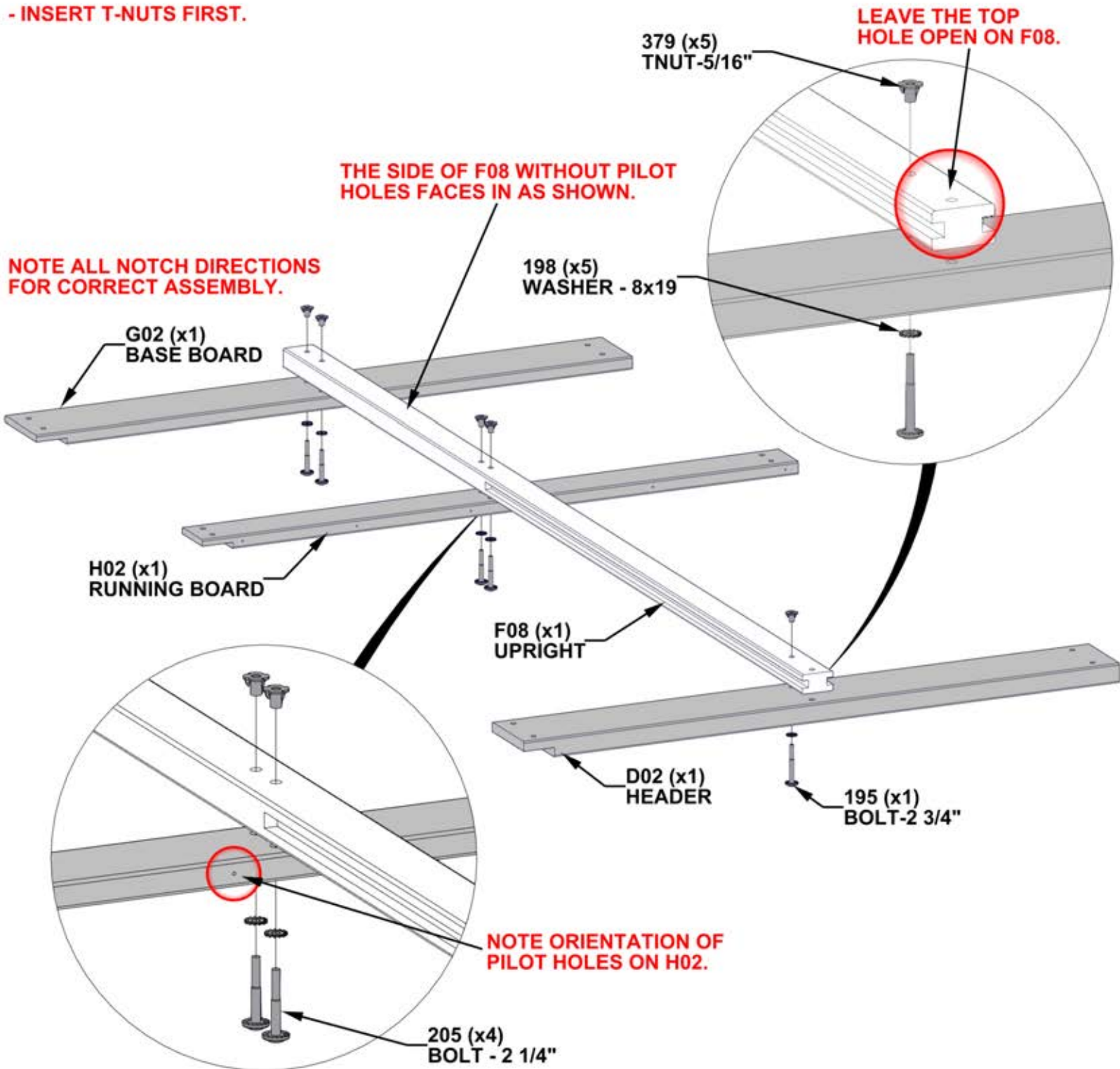

# STEP 9B - SIDE WALL ASSEMBLY

QTY	PART NUMBER	DESCRIPTION
2	H100195	BOLT WH 5/16x2 3/4 BLK
10	H100198	WASHER LOCK EXT 8x19
8	H100205	BOLT WH 5/16x2 1/4 BLK
10	H100379	TNUT-5/16" BLK

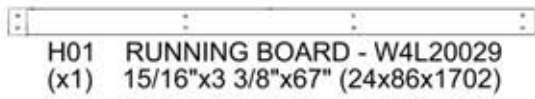
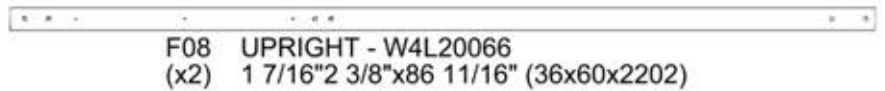
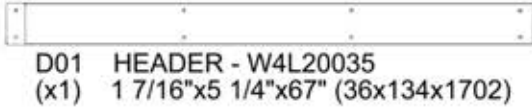

**- INSERT T-NUTS FIRST.**

**LEAVE THE TOP HOLES OPEN ON F08 BOARDS.**

**THE SIDE OF F08 WITHOUT PILOT HOLES FACES IN AS SHOWN.**

379 (x10)  
TNUT-5/16"

198 (x10)  
WASHER - 8x19

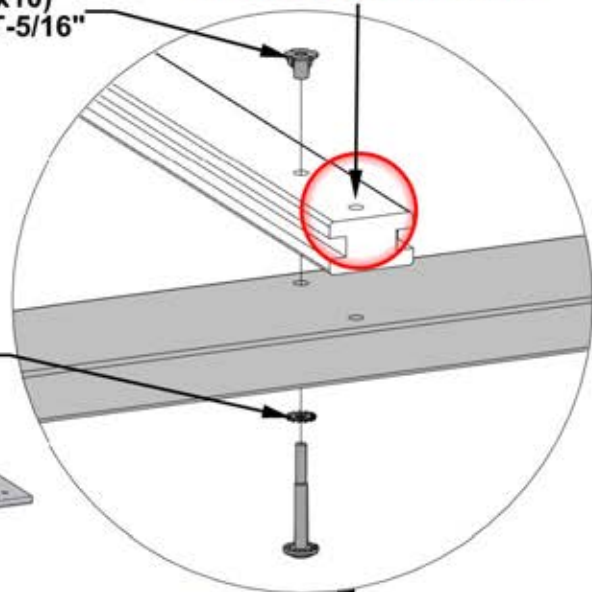

G01 (x1)  
BASE BOARD

H01 (x1)  
RUNNING BOARD

F08 (x2)  
UPRIGHT

D01 (x1)  
HEADER

195 (x2)  
BOLT-2 3/4"

**NOTE ALL NOTCH DIRECTIONS FOR CORRECT ASSEMBLY.**

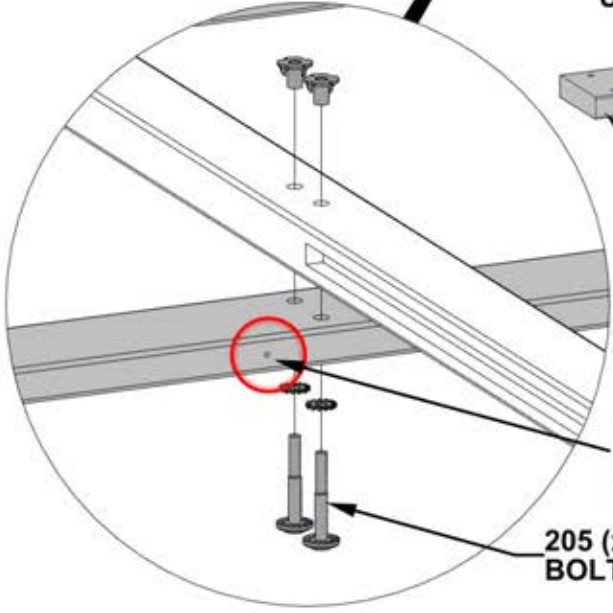

**NOTE ORIENTATION OF PILOT HOLES ON H01.**

205 (x8)  
BOLT - 2 1/4"

# STEP 9C - SIDE WALL ASSEMBLY

QTY	PART NUMBER	DESCRIPTION
2	H100193	NUT BARREL WH 5/16 X 1 1/2 BLK
1	H100195	BOLT WH 5/16x2 3/4 BLK
5	H100198	WASHER LOCK EXT 8x19
2	H100205	BOLT WH 5/16x2 1/4 BLK
3	H100379	TNUT-5/16" BLK
2	H100407	BOLT WH 5/16x1 1/2 BLK

F08 UPRIGHT - W4L20066  
(x1) 1 7/16"2 3/8"x86 11/16" (36x60x2202)



A4M03127 BRACKET  
(x1)

**- INSERT T-NUTS FIRST.**

193 (x2)  
BARREL NUT - 1 1/2"

3127 (x1)  
BRACKET

198 (x5)  
WASHER - 8x19

407 (x2)  
BOLT - 1 1/2"

**THE SIDE OF F08 WITHOUT PILOT HOLES FACES IN AS SHOWN.**

205 (x2)  
BOLT - 2 1/4"

ASSEMBLY FROM STEP 9B

ASSEMBLY FROM STEP 9A

**NOTE ALL NOTCH DIRECTIONS FOR CORRECT ASSEMBLY.**

**LEAVE THE TOP HOLE OPEN ON F08.**

F08 (x1)  
UPRIGHT

379 (x3)  
TNUT-5/16"

195 (x1)  
BOLT-2 3/4"

# STEP 10 - GREENHOUSE ASSEMBLY

QTY	PART NUMBER	DESCRIPTION
6	H100198	WASHER LOCK EXT 8x19
6	H100379	TNUT-5/16" BLK
4	H100415	BOLT WH 5/16x3 3/4 BLK
2	H100513	BOLT WH 5/16x4 1/4 BLK

STAND UP AND ATTACH SIDE ASSEMBLY AS SHOWN.

**- INSERT T-NUTS FIRST.**

**HAND TIGHTEN ONLY.**

379 (x6)  
TNUT-5/16"

513 (x2)  
BOLT - 4 1/4"

198 (x6)  
WASHER - 8x19

415 (x4)  
BOLT - 3 3/4"

SIDE ASSEMBLY  
FROM PREVIOUS STEP

# STEP 11 - FRONT WALL ASSEMBLY

QTY	PART NUMBER	DESCRIPTION
2	H100195	BOLT WH 5/16x2 3/4 BLK
6	H100198	WASHER LOCK EXT 8x19
4	H100379	TNUT-5/16" BLK
2	H100415	BOLT WH 5/16x3 3/4 BLK
2	H100458	LAG SCREW WH 5/16x2 BLK

B01 POST - W4L20028  
(x1) 3"x3"x88 3/4" (76x76x2254)

B02 POST - W4L20046  
(x1) 3"x3"x85 11/16" (76x76x2177)

G03 BASE BOARD - W4L20050  
(x1) 15/16"x5 1/4"x17 7/8" (24x134x454)

H03 RUNNING BOARD - W4L20047  
(x1) 15/16"x3 3/8"x17 7/8" (24x86x454)

**- INSERT T-NUTS FIRST.**

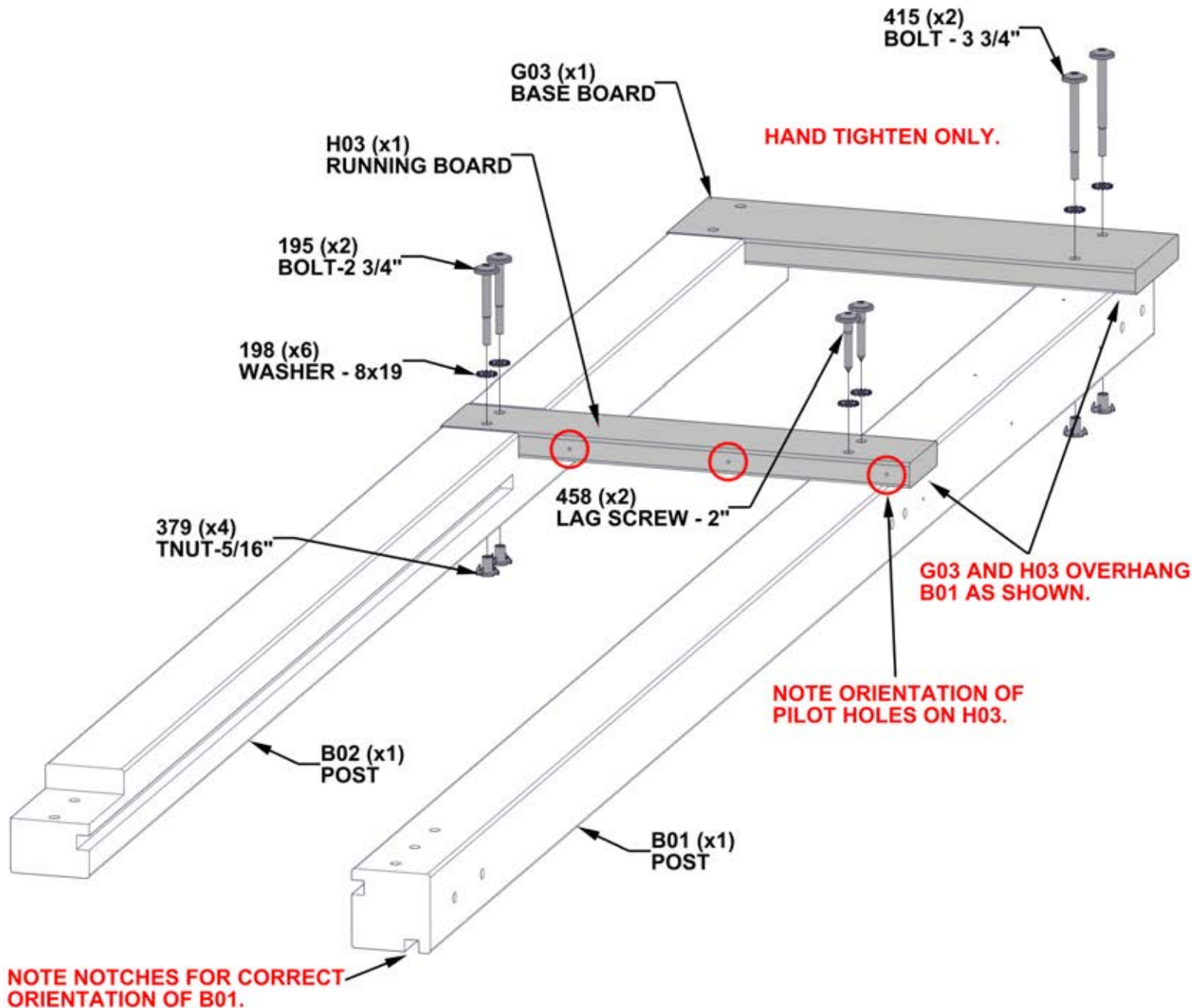

# STEP 12 - FRONT WALL ASSEMBLY

QTY	PART NUMBER	DESCRIPTION
2	H100195	BOLT WH 5/16x2 3/4 BLK
6	H100198	WASHER LOCK EXT 8x19
4	H100379	TNUT-5/16" BLK
2	H100415	BOLT WH 5/16x3 3/4 BLK
2	H100458	LAG SCREW WH 5/16x2 BLK

B03 POST - W4L20048  
(x1) 3"x3"x85 11/16" (76x76x2177)

B04 POST - W4L20065  
(x1) 3"x3"x88 3/4" (76x76x2254)

G03 BASE BOARD - W4L20050  
(x1) 15/16"x5 1/4"x17 7/8" (24x134x454)

H03 RUNNING BOARD - W4L20047  
(x1) 15/16"x3 3/8"x17 7/8" (24x86x454)

**- INSERT T-NUTS FIRST.**

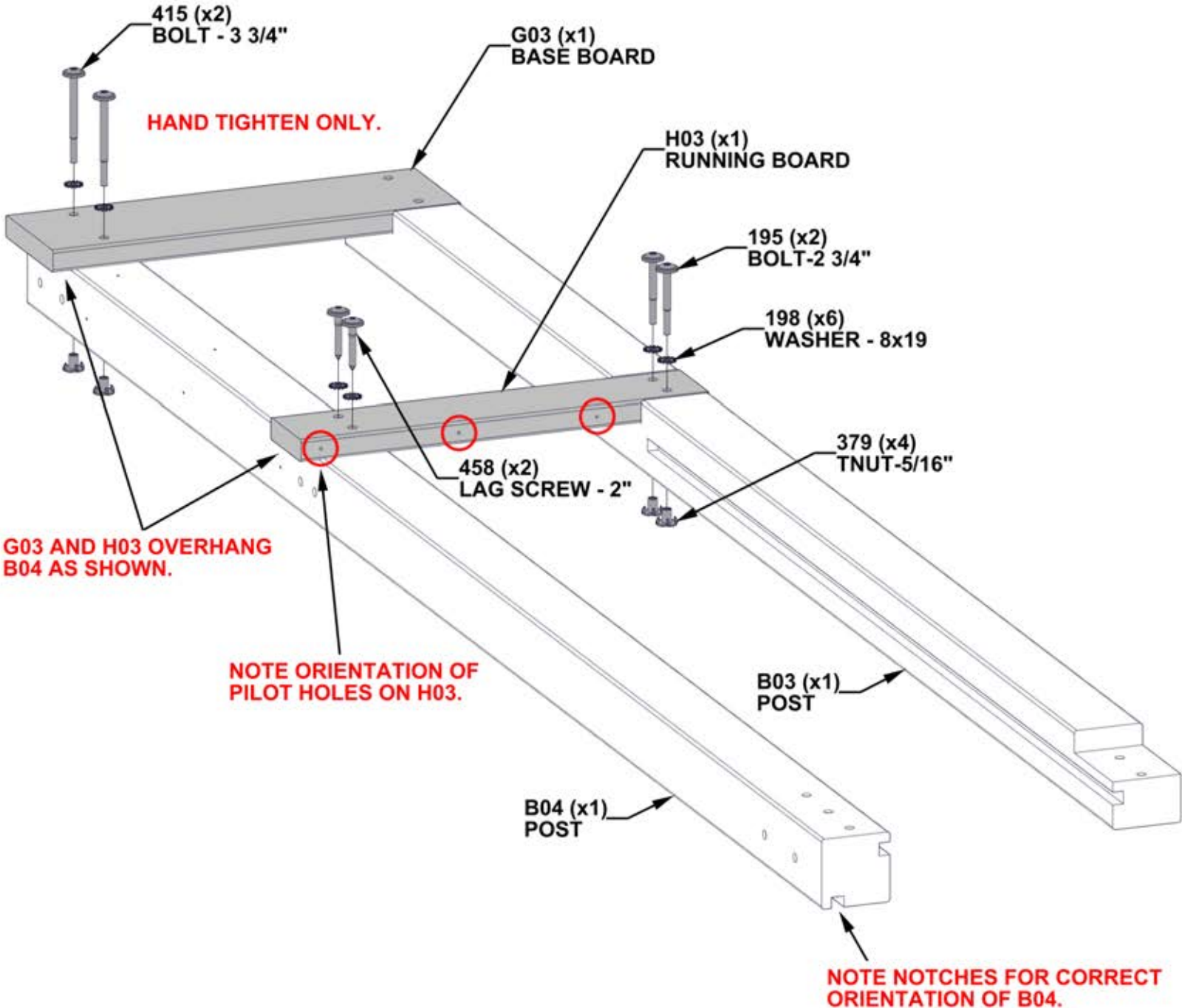

# STEP 13 - FRONT WALL ASSEMBLY

QTY	PART NUMBER	DESCRIPTION
8	H100198	WASHER LOCK EXT 8x19
8	H100379	TNUT-5/16" BLK
4	H100503	BOLT WH 5/16x3 1/2 BLK
4	H100974	BOLT WH 5/16x5 3/4 BLK



D03 HEADER - W4L20049  
(x1) 1 7/16"x5 1/4"x73 11/16" (36x134x1872)



D06 END TRIM - W4L20062  
(x2) 1 7/16"x134x219 (36x134x219)

**- INSERT T-NUTS FIRST.**

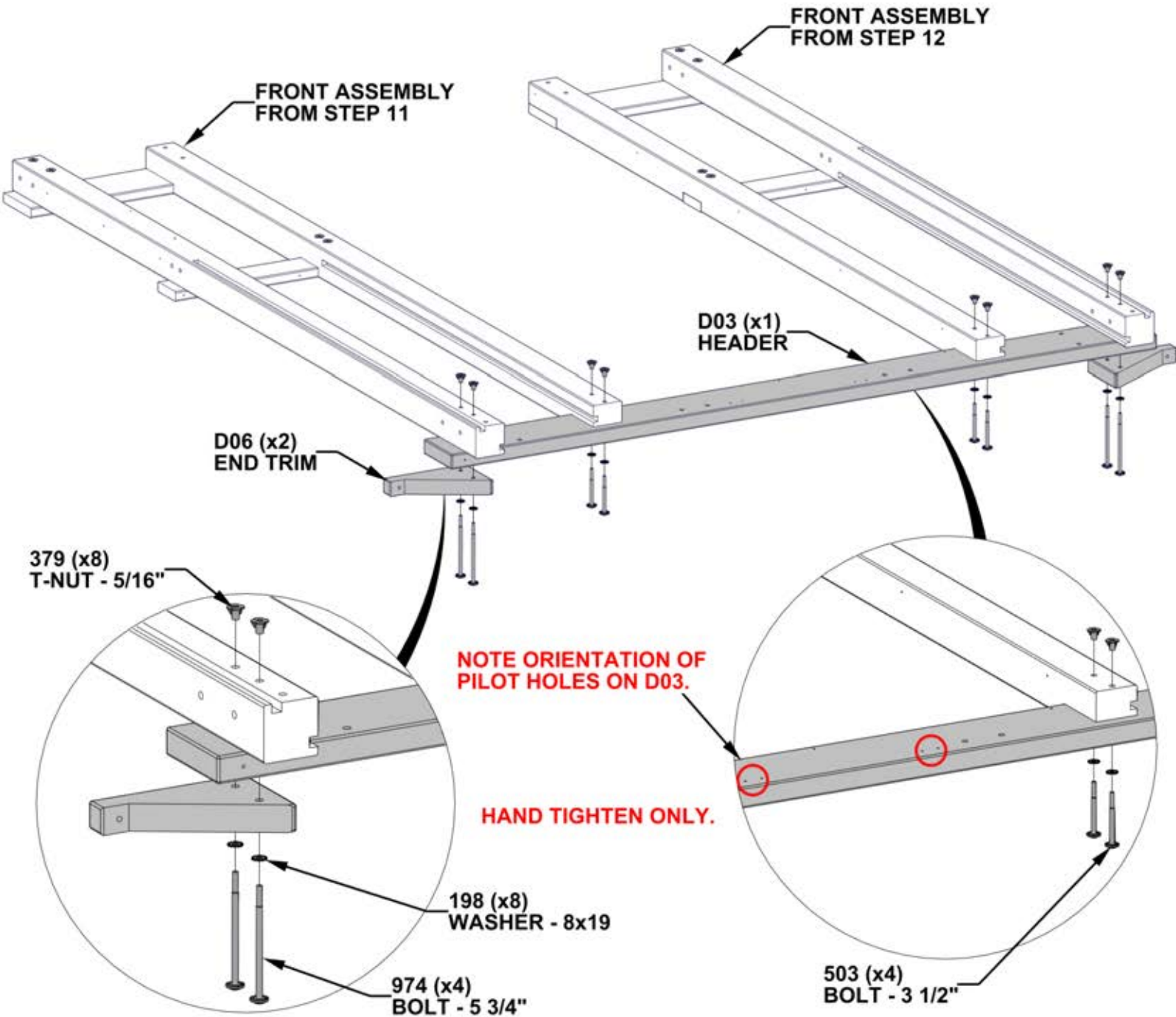

# STEP 14 - FRONT WALL ASSEMBLY

QTY	PART NUMBER	DESCRIPTION
4	H100193	NUT BARREL WH 5/16 X 1 1/2 BLK
4	H100198	WASHER LOCK EXT 8x19
4	H100205	BOLT WH 5/16x2 1/4 BLK

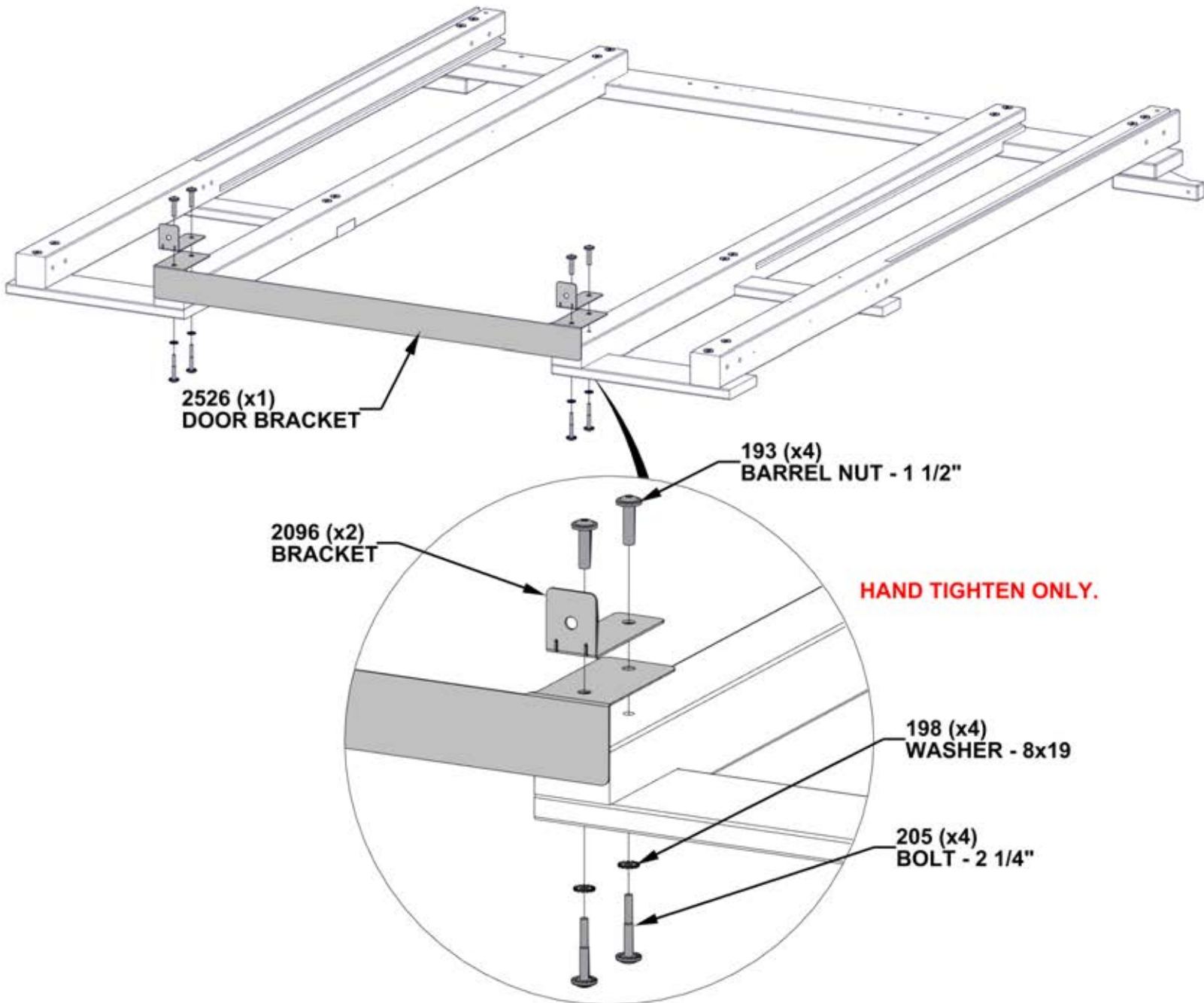
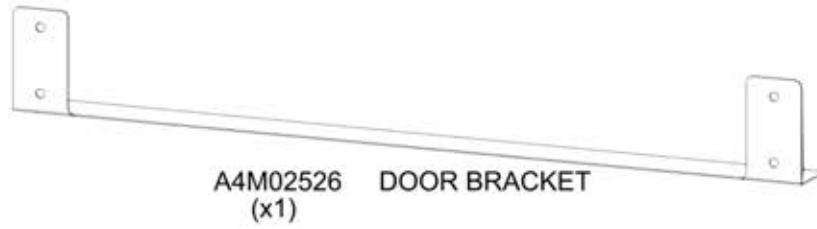
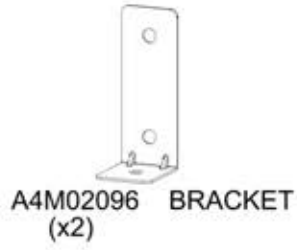

# STEP 15 - FRONT WALL ASSEMBLY

QTY	PART NUMBER	DESCRIPTION
8	H100379	T-NUT 5/16 BLK
8	H100459	BOLT WH 5/16x1 1/4 BLK

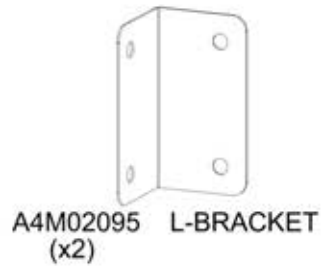

**- INSERT T-NUTS FIRST.**

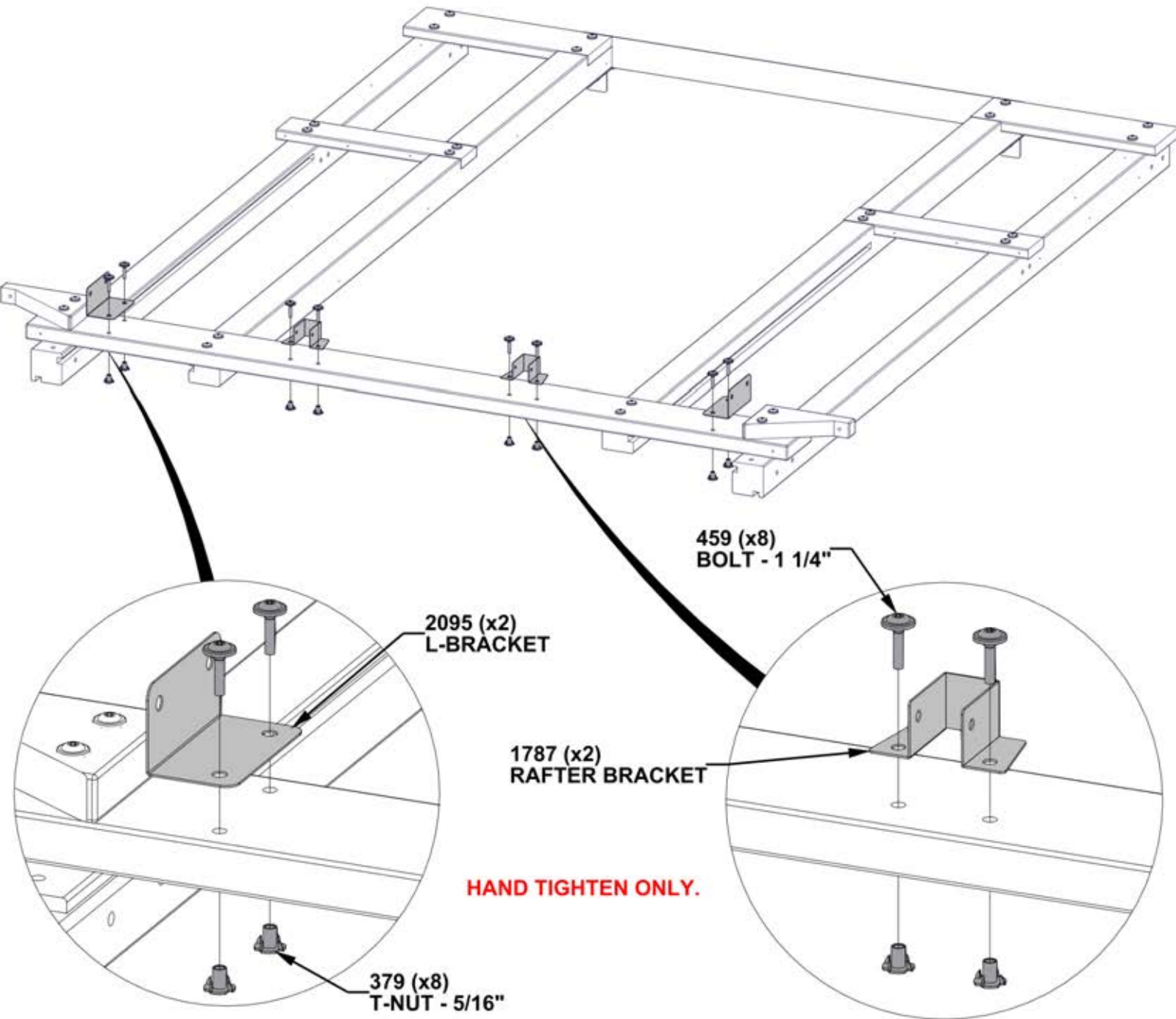

**ENSURE CORRECT ORIENTATION OF BRACKETS AS SHOWN.**

# STEP 16 - GREENHOUSE ASSEMBLY

QTY	PART NUMBER	DESCRIPTION
12	H100198	WASHER LOCK EXT 8x19
12	H100379	TNUT-5/16" BLK
8	H100415	BOLT WH 5/16x3 3/4 BLK
4	H100513	BOLT WH 5/16x4 1/4 BLK

STAND UP FRONT WALL ASSEMBLY AND ATTACH AS SHOWN.

**- INSERT T-NUTS FIRST.**

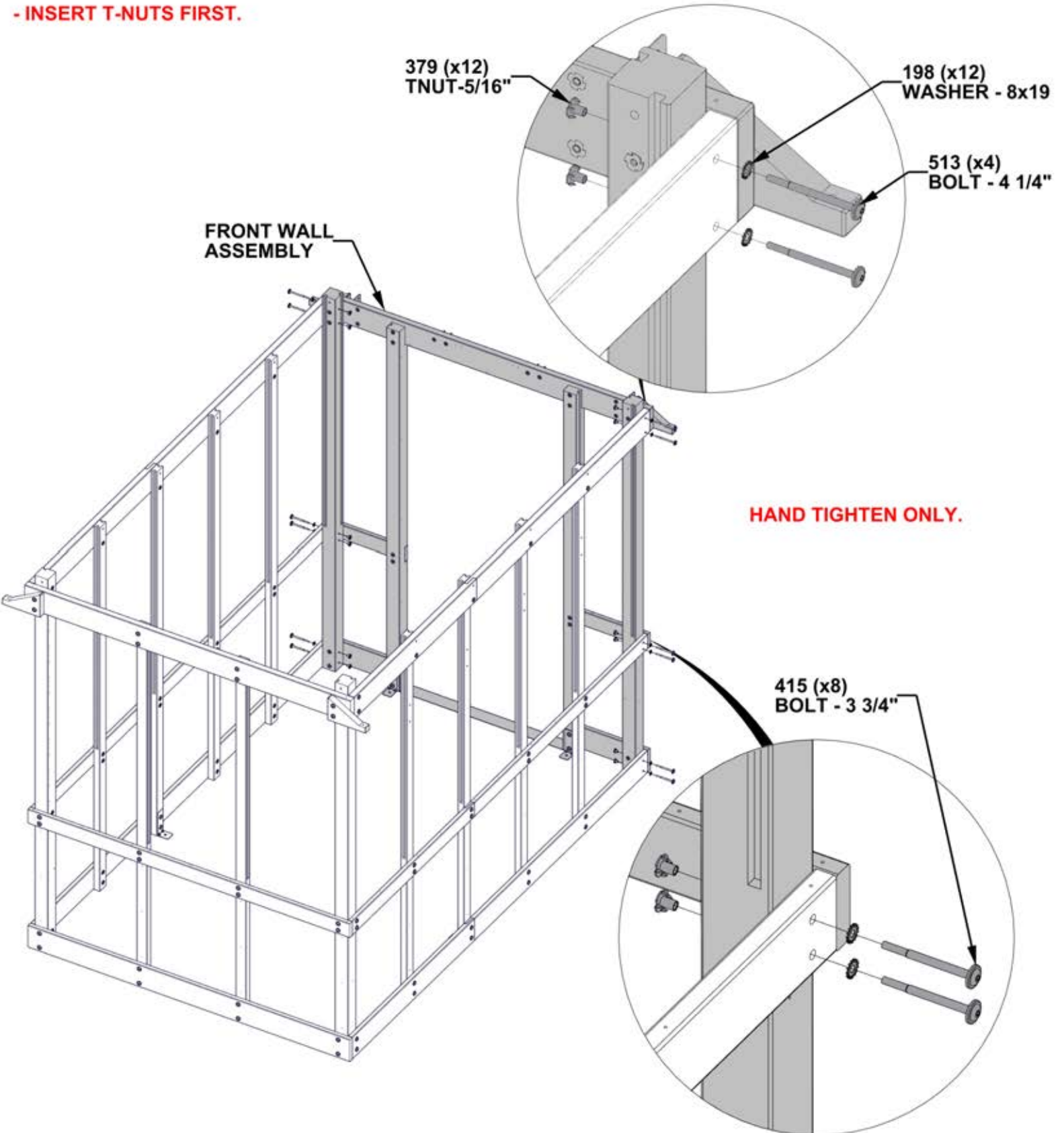

# STEP 17 - RAFTER BRACKET ASSEMBLY

QTY	PART NUMBER	DESCRIPTION
8	H100195	BOLT WH 5/16x2 3/4 BLK
8	H100379	TNUT-5/16" BLK



A4M02093 RAFTER BRACKET  
(x8)

**- INSERT T-NUTS FIRST.**

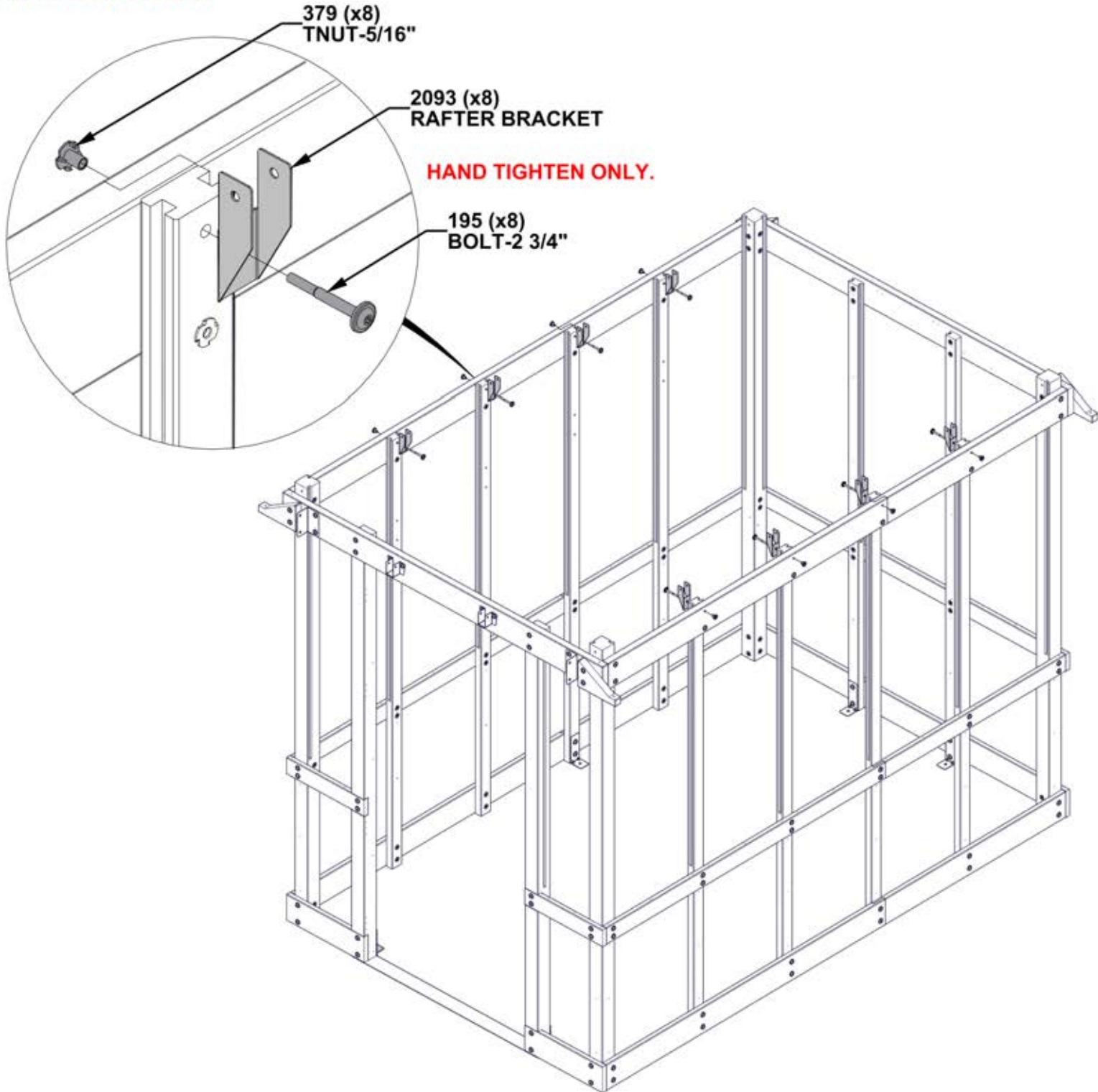

# STEP 18 - GREENHOUSE ASSEMBLY

## IMPORTANT!

STARTING WITH THE FRONT WALL ASSEMBLY, THE FOLLOWING STEPS ARE CRITICAL:

- POSTS AND UPRIGHTS ARE PLUMB (STRAIGHT UP AND DOWN) WITH A LEVEL.
- MEASUREMENTS BETWEEN POSTS AND UPRIGHTS ARE AS SHOWN +/- 1/8".
- RUNNING AND BASE BOARDS ARE SQUARED TO THE UPRIGHTS.
- ALL HARDWARE ON THIS SIDE IS FULLY TIGHTENED.

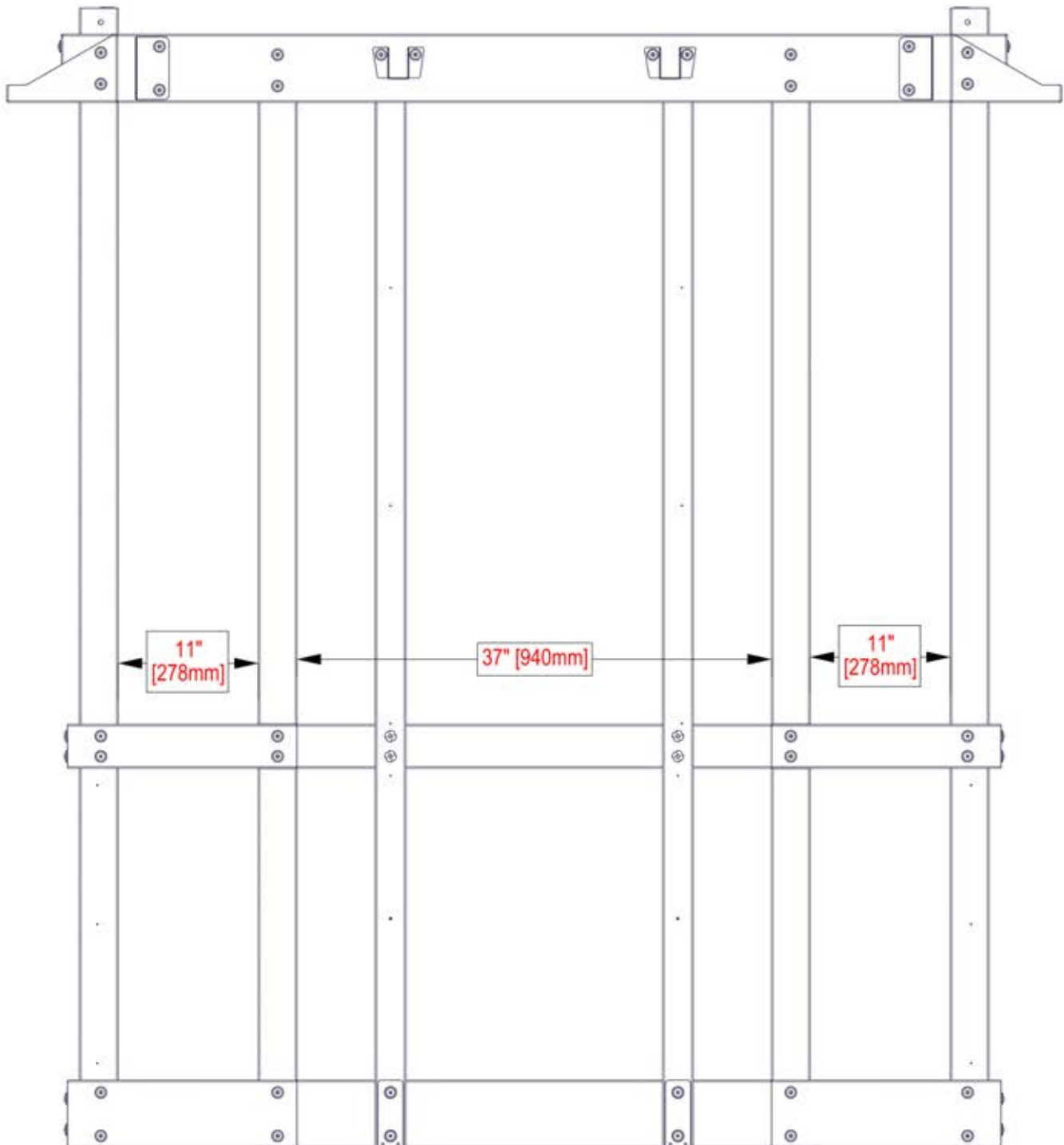

# STEP 19 - GREENHOUSE ASSEMBLY

## IMPORTANT!

ON THE SIDE WALL ASSEMBLY, THE FOLLOWING STEPS ARE CRITICAL:

- POSTS AND UPRIGHTS ARE PLUMB (STRAIGHT UP AND DOWN) WITH A LEVEL.
- MEASUREMENTS BETWEEN POSTS AND UPRIGHTS ARE 19" +/- 1/8" [482mm] AS SHOWN.
- RUNNING AND BASE BOARDS ARE SQUARED TO THE UPRIGHTS.
- ALL HARDWARE ON THIS SIDE IS FULLY TIGHTENED.



## STEP 20 - GREENHOUSE ASSEMBLY

### IMPORTANT!

- ON THE BACK WALL ASSEMBLY, THE FOLLOWING STEPS ARE CRITICAL:
- POSTS AND UPRIGHTS ARE PLUMB (STRAIGHT UP AND DOWN) WITH A LEVEL.
  - MEASUREMENTS BETWEEN POSTS AND UPRIGHTS ARE AS SHOWN +/- 1/8".
  - RUNNING AND BASE BOARDS ARE SQUARED TO THE UPRIGHTS.
  - ALL HARDWARE ON THIS SIDE IS FULLY TIGHTENED.

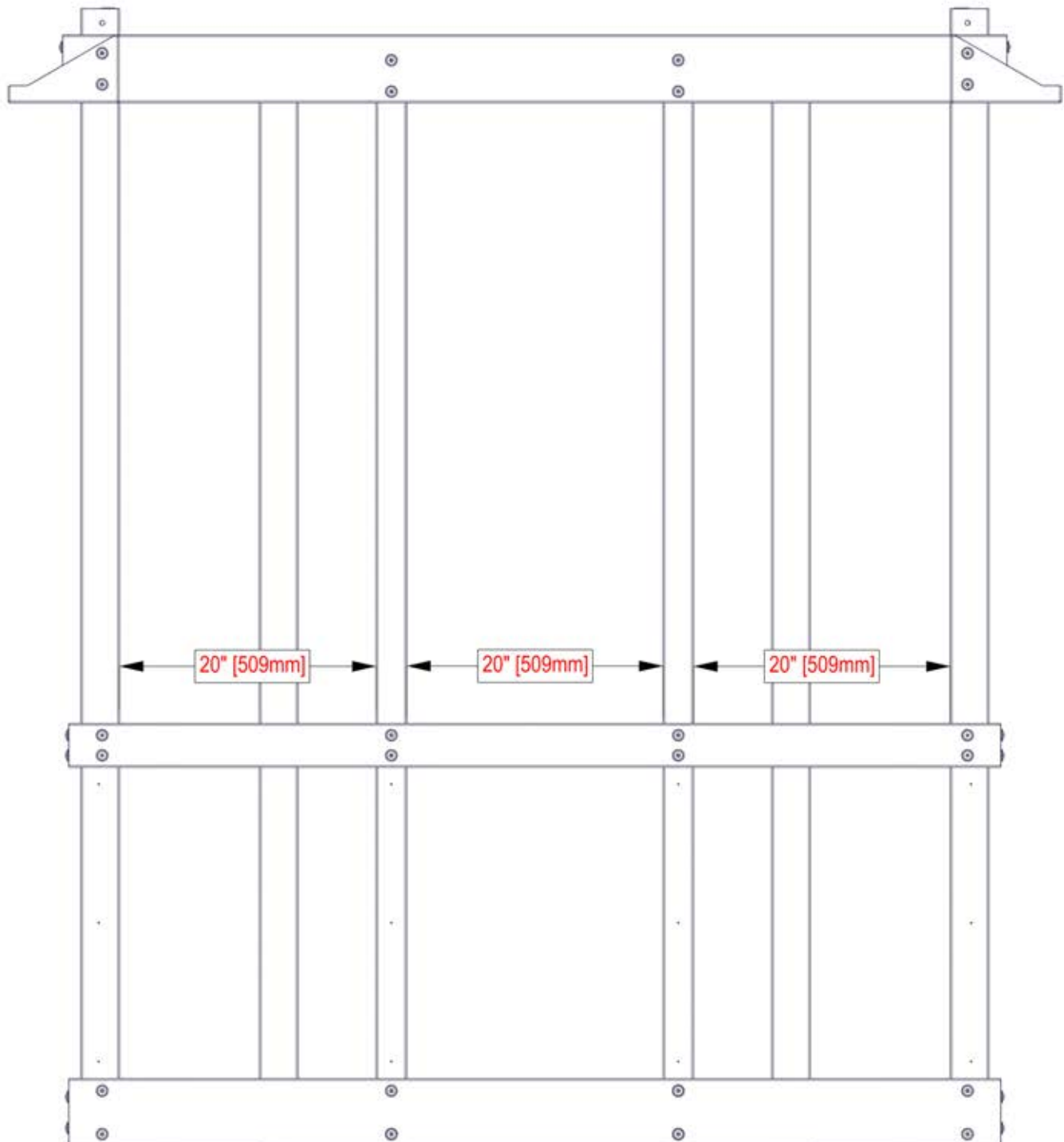

## STEP 21 - GREENHOUSE ASSEMBLY

### IMPORTANT!

ON THE REMAINING SIDE WALL ASSEMBLY, THE FOLLOWING STEPS ARE CRITICAL:

- POSTS AND UPRIGHTS ARE PLUMB (STRAIGHT UP AND DOWN) WITH A LEVEL.
- MEASUREMENTS BETWEEN POSTS AND UPRIGHTS ARE 19" +/- 1/8" [482mm] AS SHOWN.
- RUNNING AND BASE BOARDS ARE SQUARED TO THE UPRIGHTS.
- ALL HARDWARE ON THIS SIDE IS FULLY TIGHTENED.

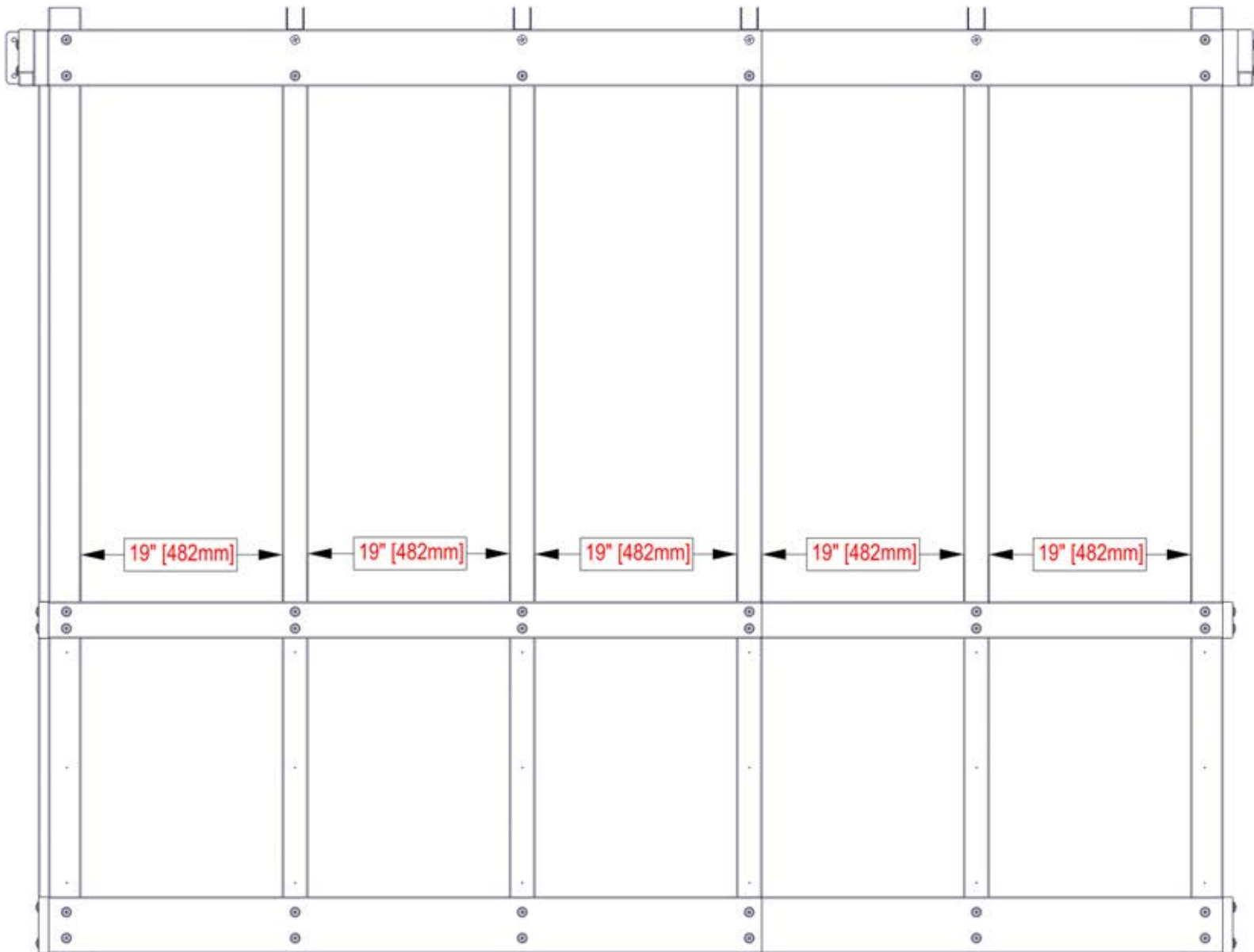

# STEP 22 - GREENHOUSE ASSEMBLY

**CRITICAL: SQUARE ASSEMBLY BEFORE PROCEEDING TO NEXT STEPS.**

**WARNING: THERE WILL BE ALIGNMENT ISSUES IF THE STRUCTURE IS NOT PROPERLY SQUARED.**

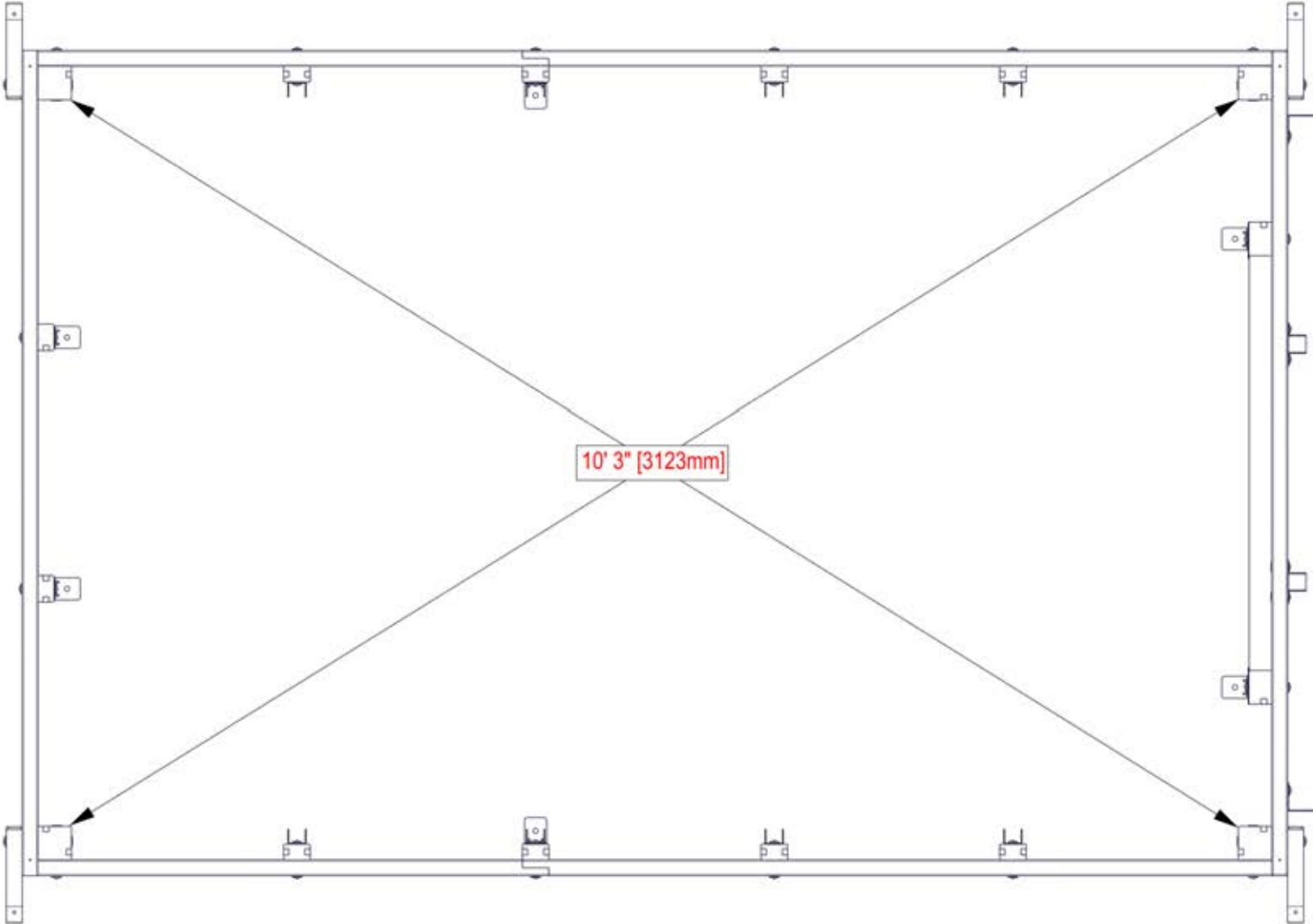

# STEP 23 - SIDE WALL ASSEMBLY

QTY	PART NUMBER	DESCRIPTION
60	H100382	SCREW PFH 8x1 3/4 BLK



WP01 WALL PANEL - W2A04324  
(x4) 1 1/16"x18 7/8"x31 9/16" (27x480x802)

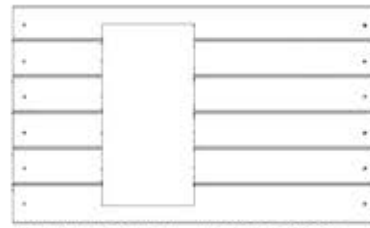

WP02 WALL PANEL - W2A04326  
(x1) 1 1/16"x18 7/8"x31 9/16" (27x480x802)

- TOP OF PANELS SHOULD BE FLUSH WITH TOP OF RUNNING BOARD.
- CENTER BETWEEN POSTS AND UPRIGHTS.
- ATTACH AS SHOWN.

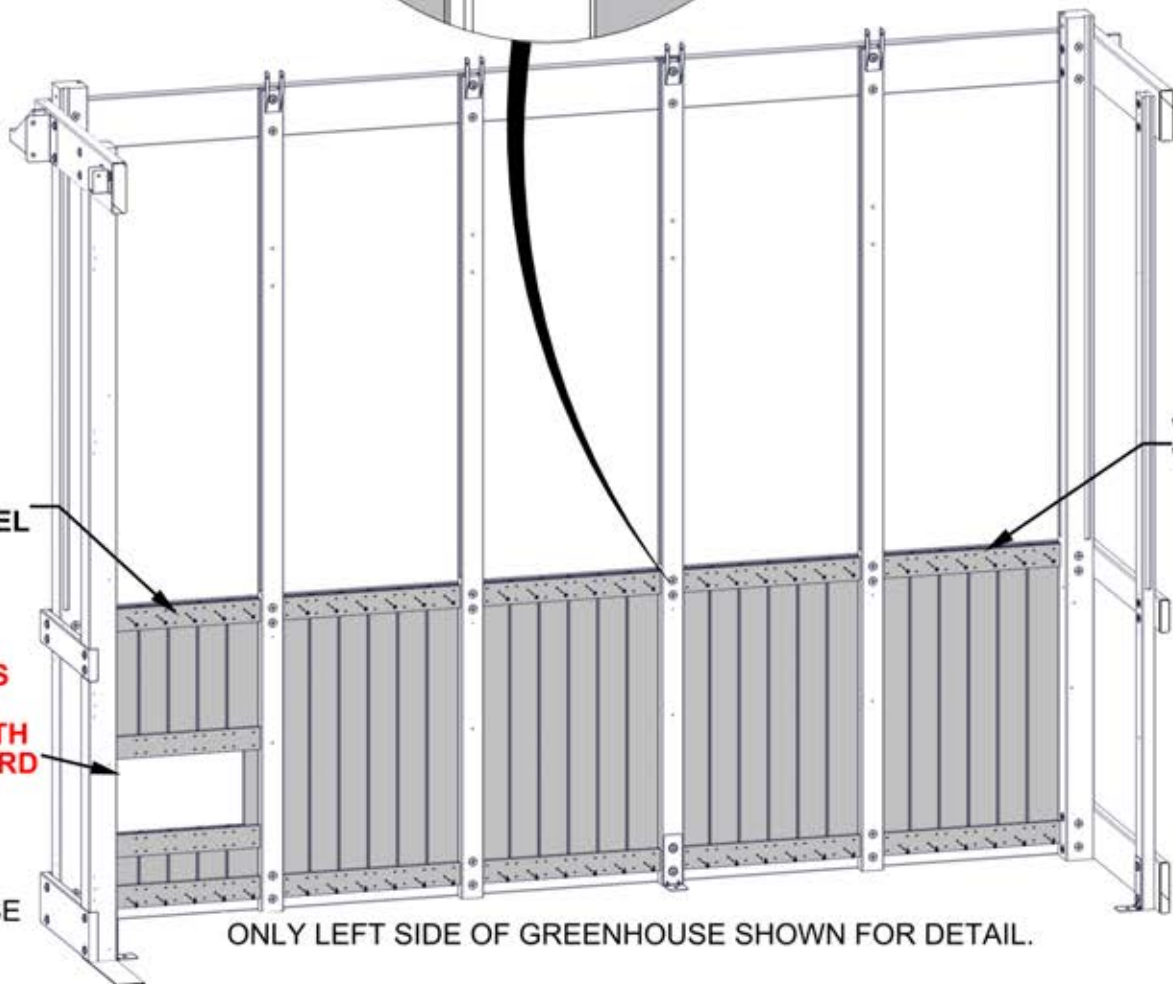
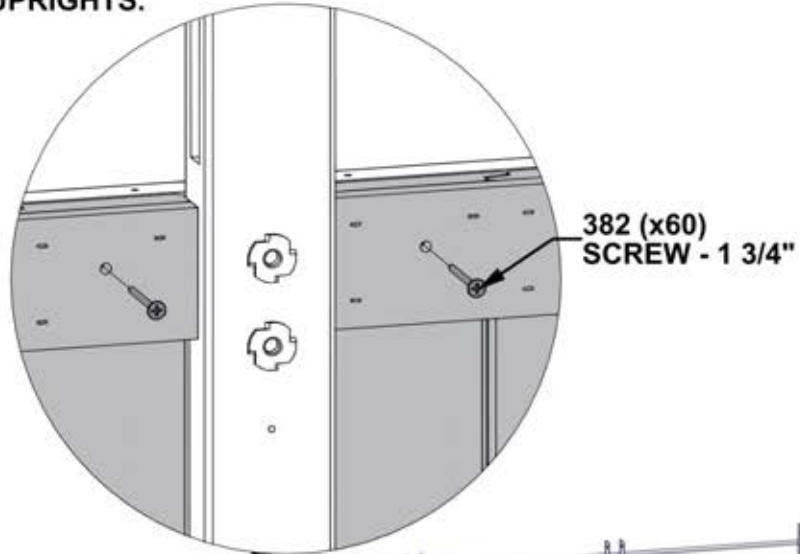

ONLY LEFT SIDE OF GREENHOUSE SHOWN FOR DETAIL.

# STEP 24 - BACK WALL ASSEMBLY

QTY	PART NUMBER	DESCRIPTION
36	H100382	SCREW PFH 8x1 3/4 BLK



WP04 WALL PANEL - W2A04332  
(x1) 1 3/16"x19 15/16"x31 9/16" (30x507x802)



WP05 WALL PANEL - W2A04333  
(x2) 1 3/16"x19 15/16"x31 9/16" (30x507x802)

- TOP OF PANELS SHOULD BE FLUSH WITH TOP OF RUNNING BOARD.
- CENTER BETWEEN POSTS AND UPRIGHTS.
- ATTACH AS SHOWN.

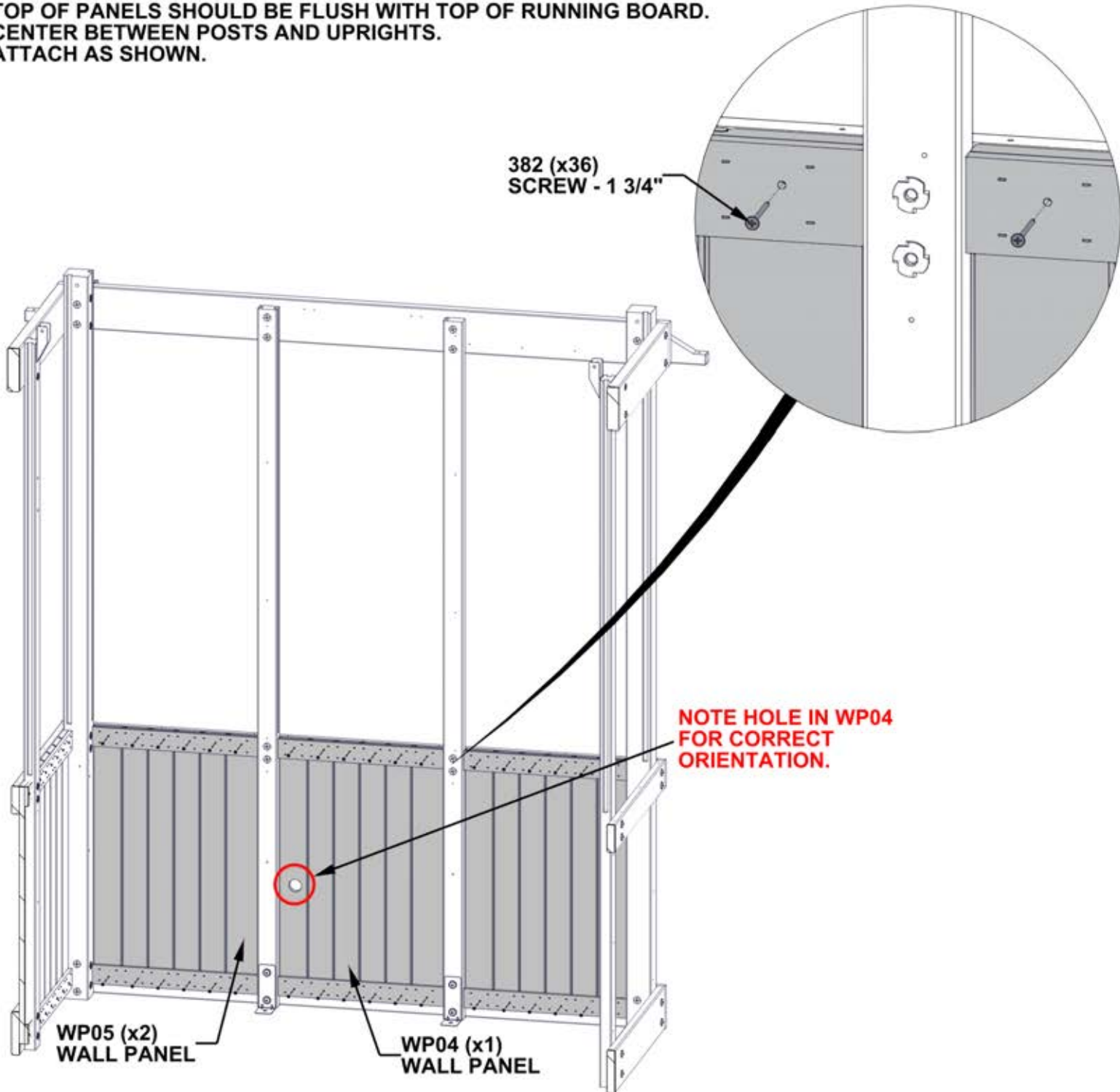

ONLY BACK SIDE OF GREENHOUSE SHOWN FOR DETAIL.

# STEP 25 - SIDE WALL ASSEMBLY

QTY	PART NUMBER	DESCRIPTION
60	H100382	SCREW PFH 8x1 3/4 BLK



WP01 WALL PANEL - W2A04324  
(x4) 1 1/16"x18 7/8"x31 9/16" (27x480x802)

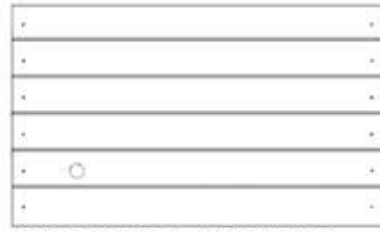

WP06 WALL PANEL - W2A04334  
(x1) 1 1/16"x18 7/8"x31 9/16" (27x480x802)

- TOP OF PANELS SHOULD BE FLUSH WITH TOP OF RUNNING BOARD.
- CENTER BETWEEN POSTS AND UPRIGHTS.
- ATTACH AS SHOWN.

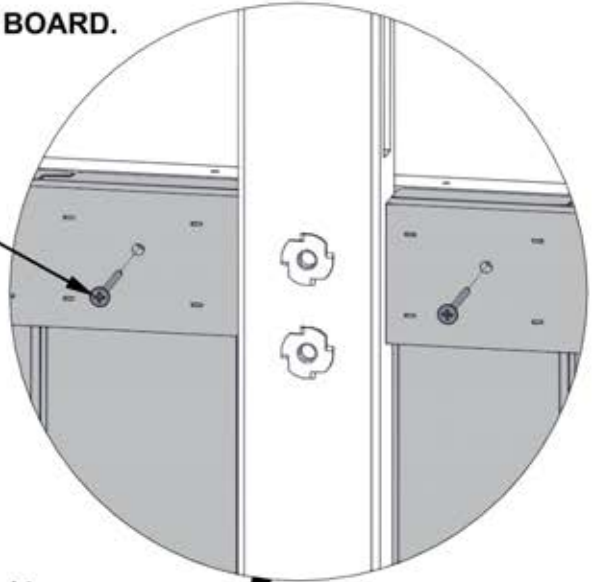

382 (x60)  
SCREW - 1 3/4"

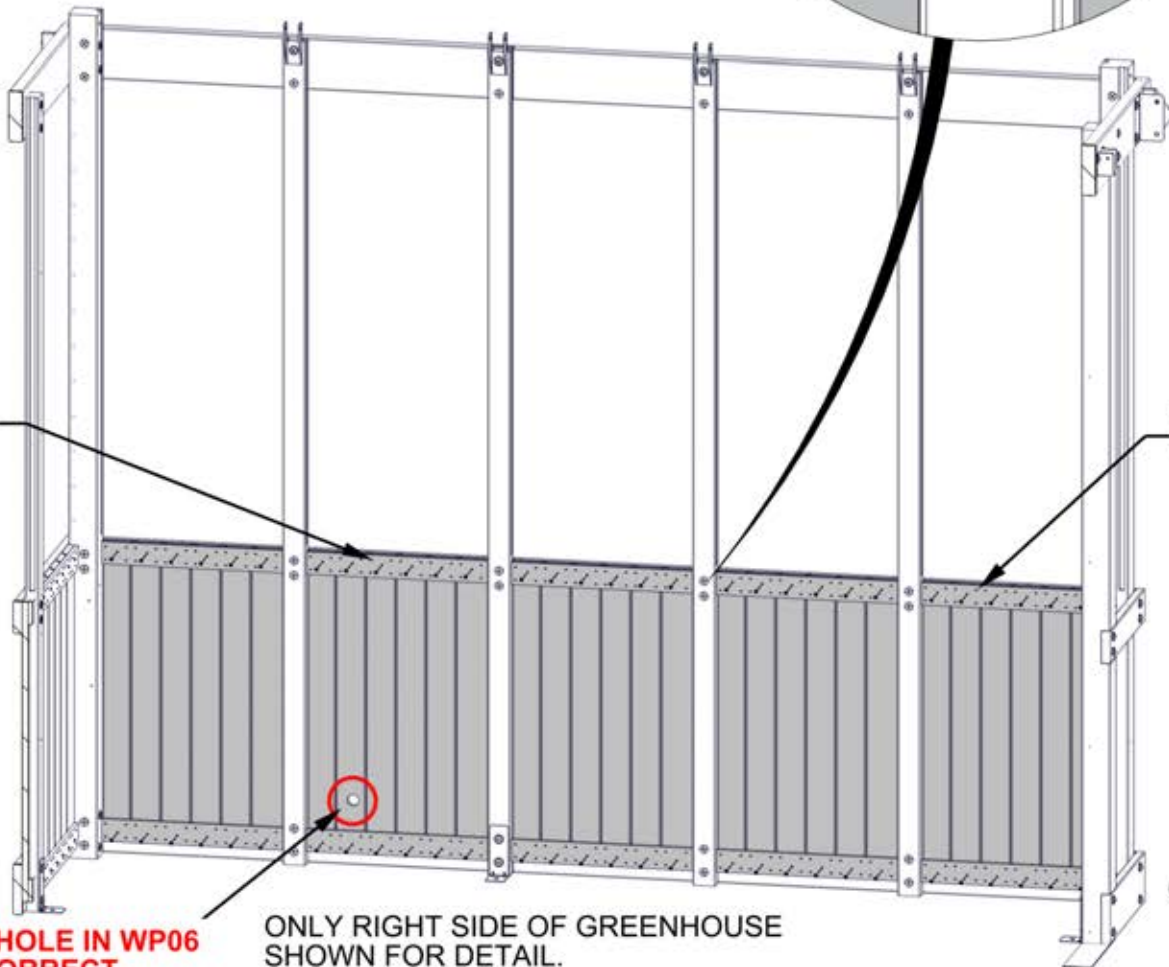

WP06 (x1)  
WALL PANEL

WP01 (x4)  
WALL PANEL

GREENHOUSE  
FRONT

**NOTE HOLE IN WP06  
FOR CORRECT  
ORIENTATION.**

ONLY RIGHT SIDE OF GREENHOUSE  
SHOWN FOR DETAIL.

# STEP 26 - FRONT WALL ASSEMBLY

QTY	PART NUMBER	DESCRIPTION
16	H100382	SCREW PFH 8x1 3/4 BLK



WP03 WALL PANEL - W2A04329  
(x2) 6 15/16"x10 7/8"x31 9/16" (177x276x802)

- TOP OF PANELS SHOULD BE FLUSH WITH TOP OF RUNNING BOARD.
- CENTER BETWEEN POSTS AND UPRIGHTS.
- ATTACH AS SHOWN.

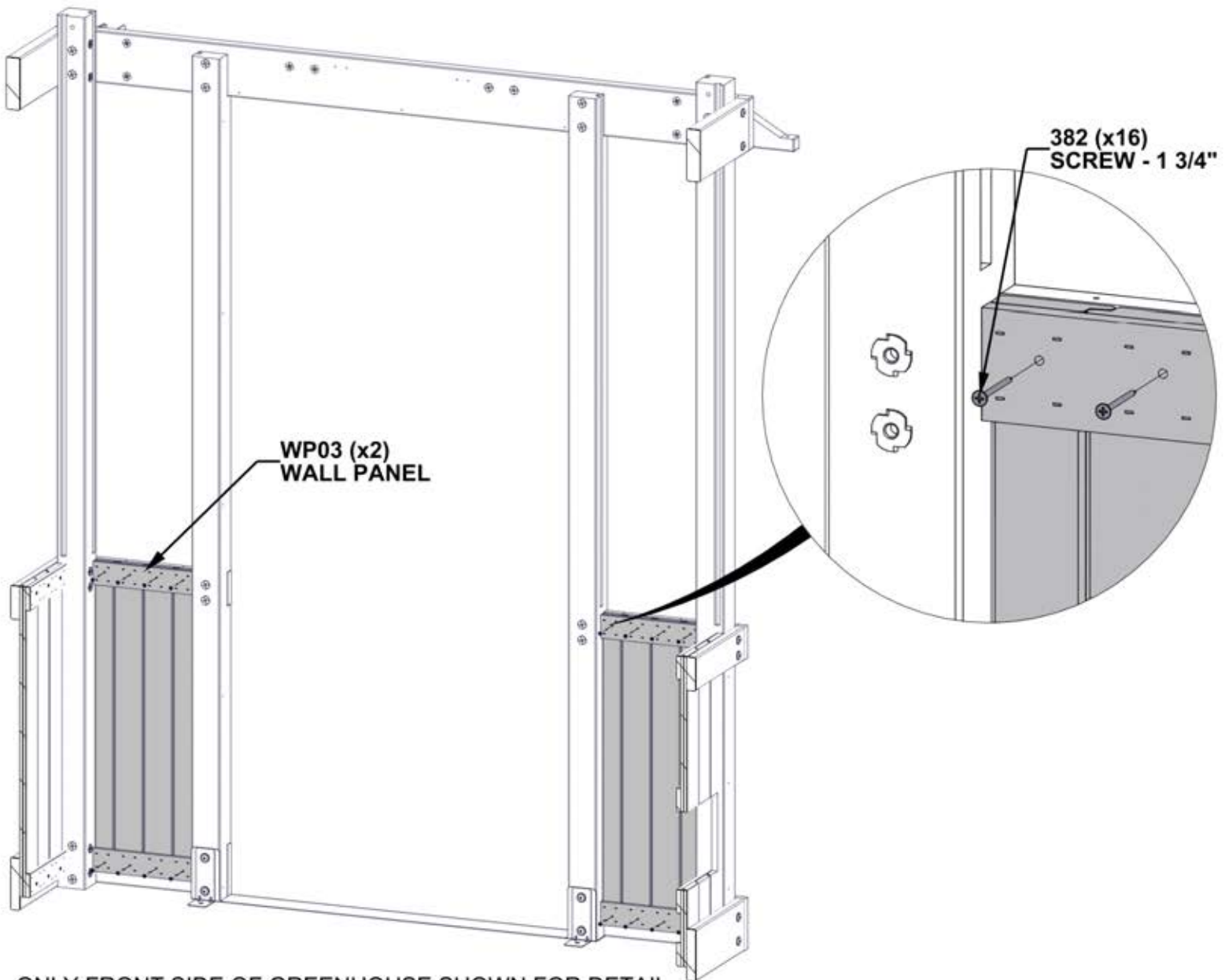

ONLY FRONT SIDE OF GREENHOUSE SHOWN FOR DETAIL.

# STEP 27 - WINDOW SILL ASSEMBLY

QTY	PART NUMBER	DESCRIPTION
15	H100391	SCREW PFH 8x2 BLK



E01 WINDOW SILL - W4L20032  
(x1) 1 7/16"x3 3/8"x23 1/8" (36x86x588)



E02 WINDOW SILL - W4L20033  
(x3) 1 7/16"x3 3/8"x21 5/16" (36x86x542)



E03 WINDOW SILL - W4L20034  
(x1) 1 7/16"x3 3/8"x23 1/8" (36x86x588)

ATTACH WINDOW SILLS USING  
PILOT HOLES IN RUNNING BOARDS.

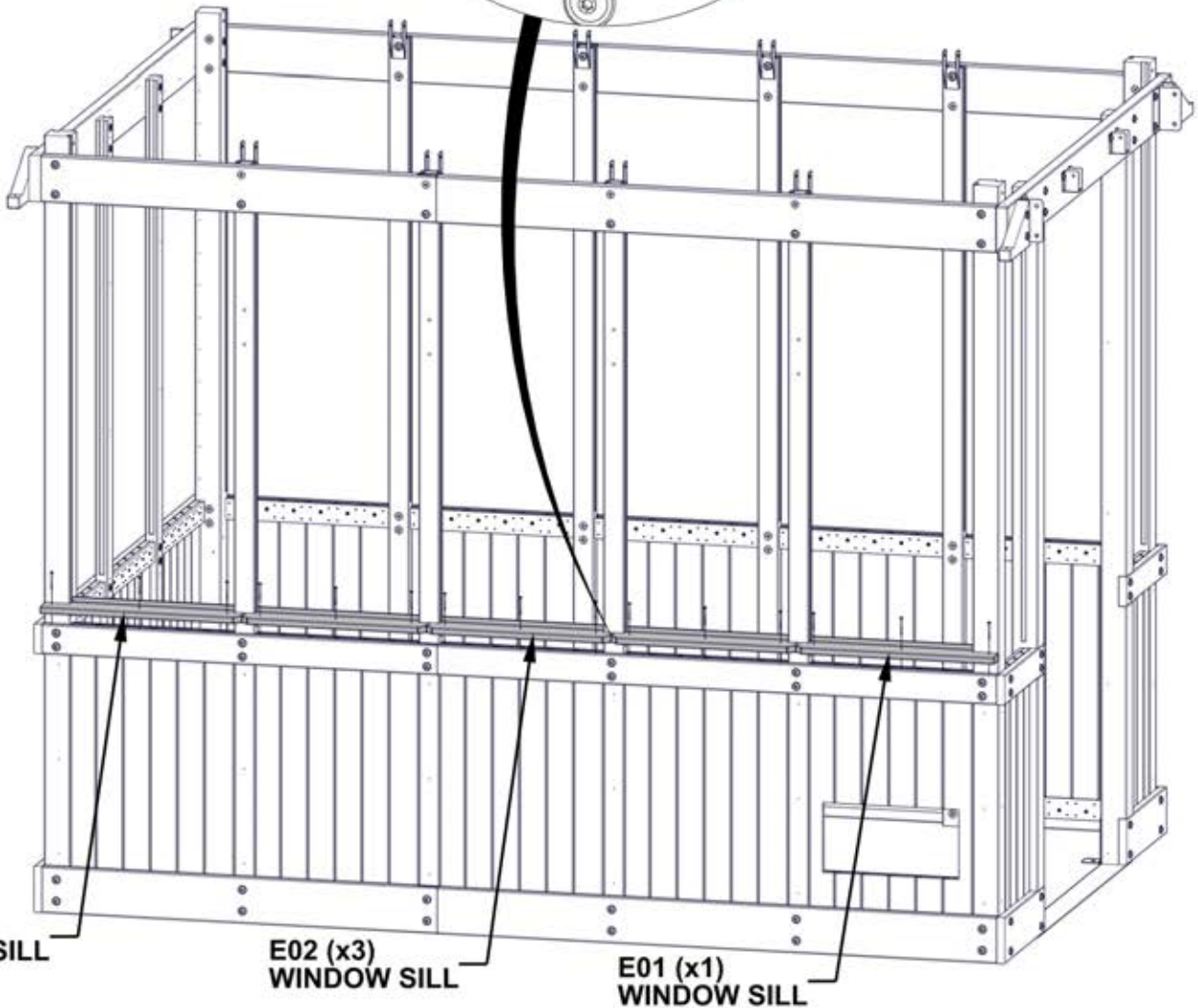
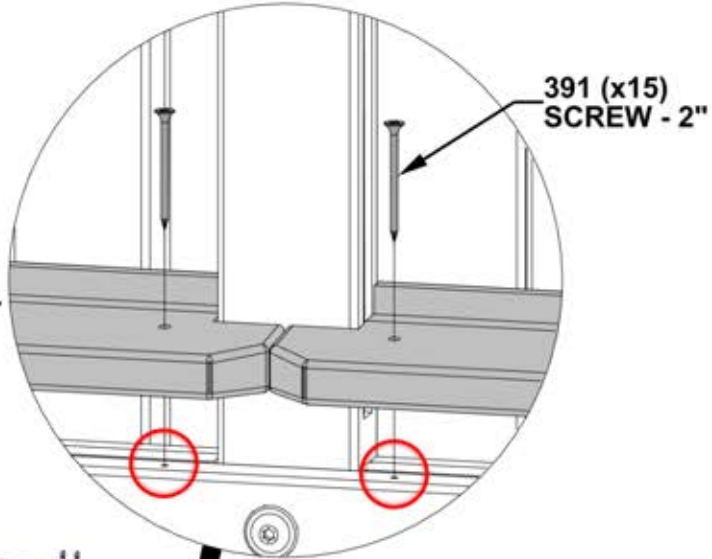

# STEP 28 - WINDOW SILL ASSEMBLY

QTY	PART NUMBER	DESCRIPTION
9	H100391	SCREW PFH 8x2 BLK

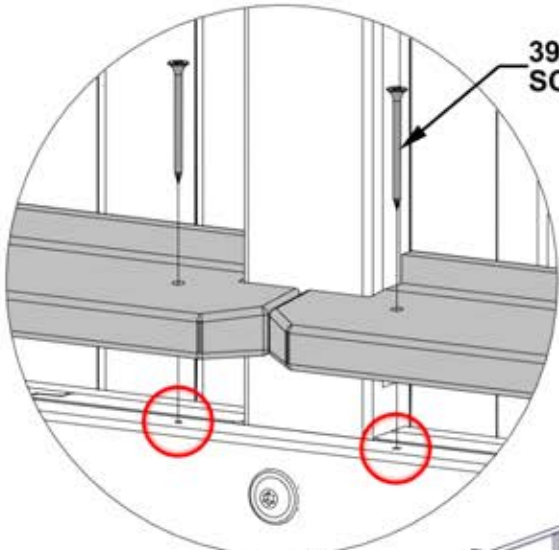
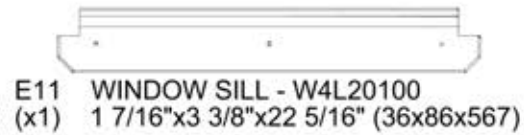
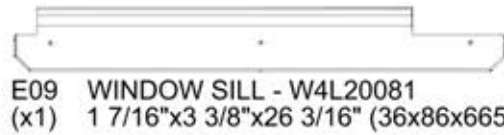
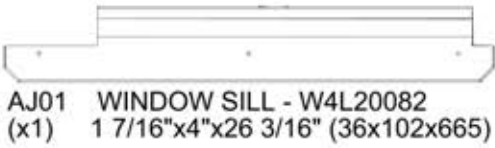

**ATTACH WINDOW SILLS USING PILOT HOLES IN RUNNING BOARD.**

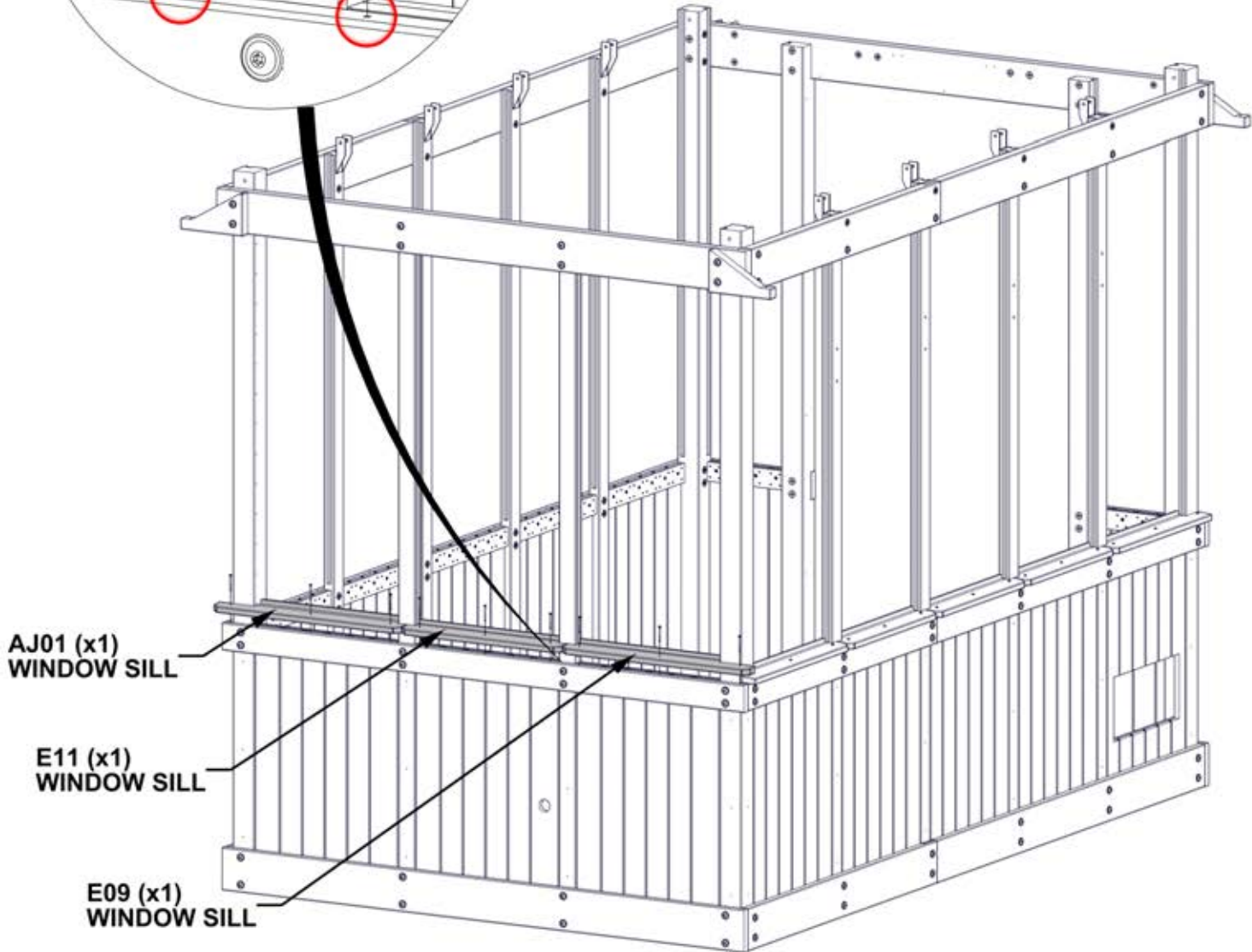

# STEP 29 - WINDOW SILL ASSEMBLY

QTY	PART NUMBER	DESCRIPTION
15	H100391	SCREW PFH 8x2 BLK



E01 WINDOW SILL - W4L20032  
(x1) 1 7/16"x3 3/8"x23 1/8" (36x86x588)



E02 WINDOW SILL - W4L20033  
(x3) 1 7/16"x3 3/8"x21 5/16" (36x86x542)



E03 WINDOW SILL - W4L20034  
(x1) 1 7/16"x3 3/8"x23 1/8" (36x86x588)

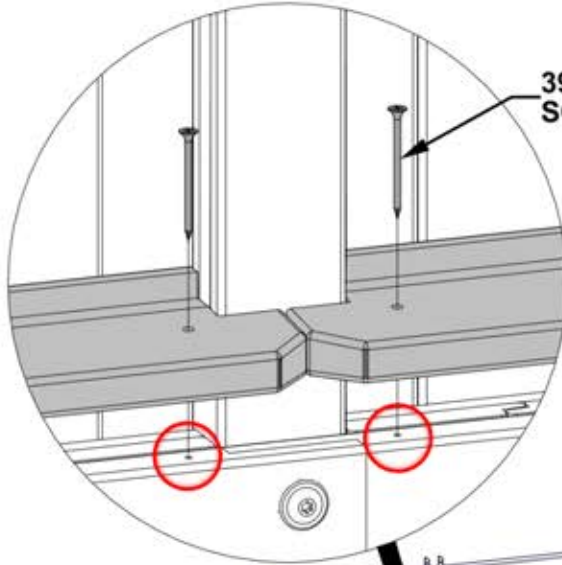

391 (x15)  
SCREW - 2"

ATTACH WINDOW SILLS USING  
PILOT HOLES IN RUNNING BOARDS.

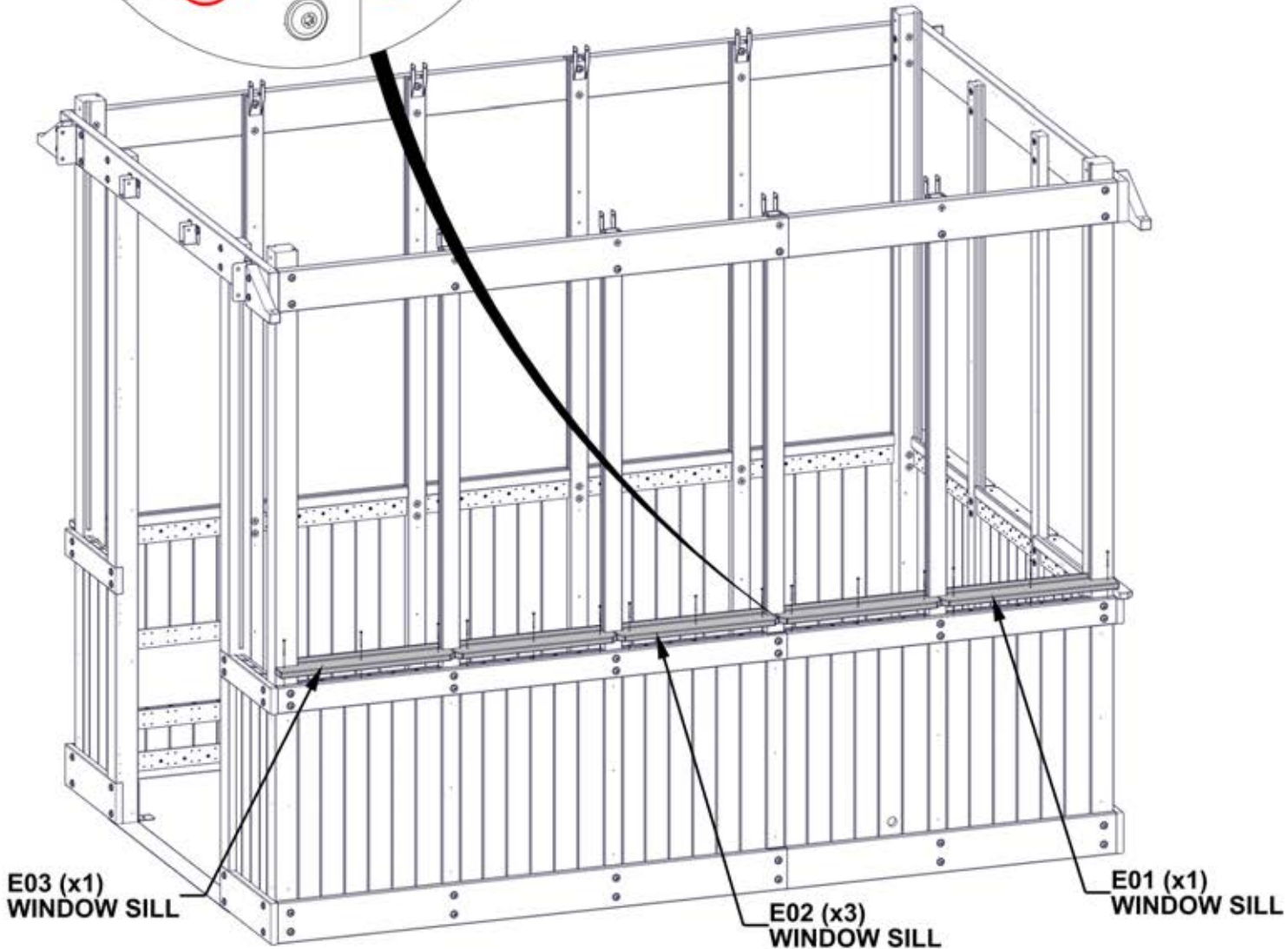

E03 (x1)  
WINDOW SILL

E02 (x3)  
WINDOW SILL

E01 (x1)  
WINDOW SILL

# STEP 30 - WINDOW SILL ASSEMBLY

QTY	PART NUMBER	DESCRIPTION
6	H100391	SCREW PFH 8x2 BLK



E04 WINDOW SILL - W4L20051  
(x1) 1 7/16"x3 3/8"x15 7/8" (36x86x403)



E05 WINDOW SILL - W4L20052  
(x1) 1 7/16"x3 3/8"x15 7/8" (36x86x403)

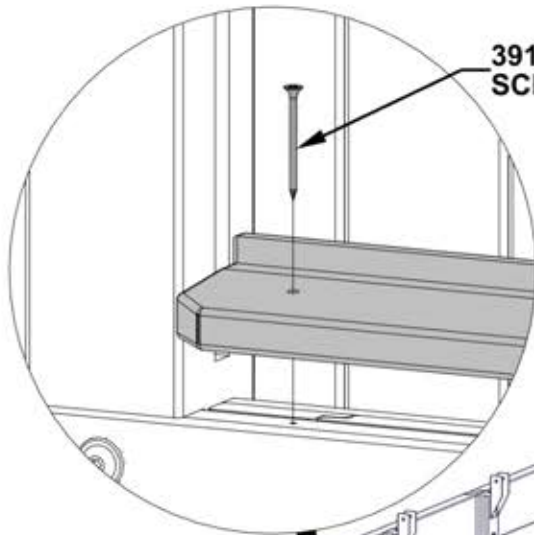

391 (x6)  
SCREW - 2"

ATTACH WINDOW SILLS USING  
PILOT HOLES IN RUNNING BOARDS.

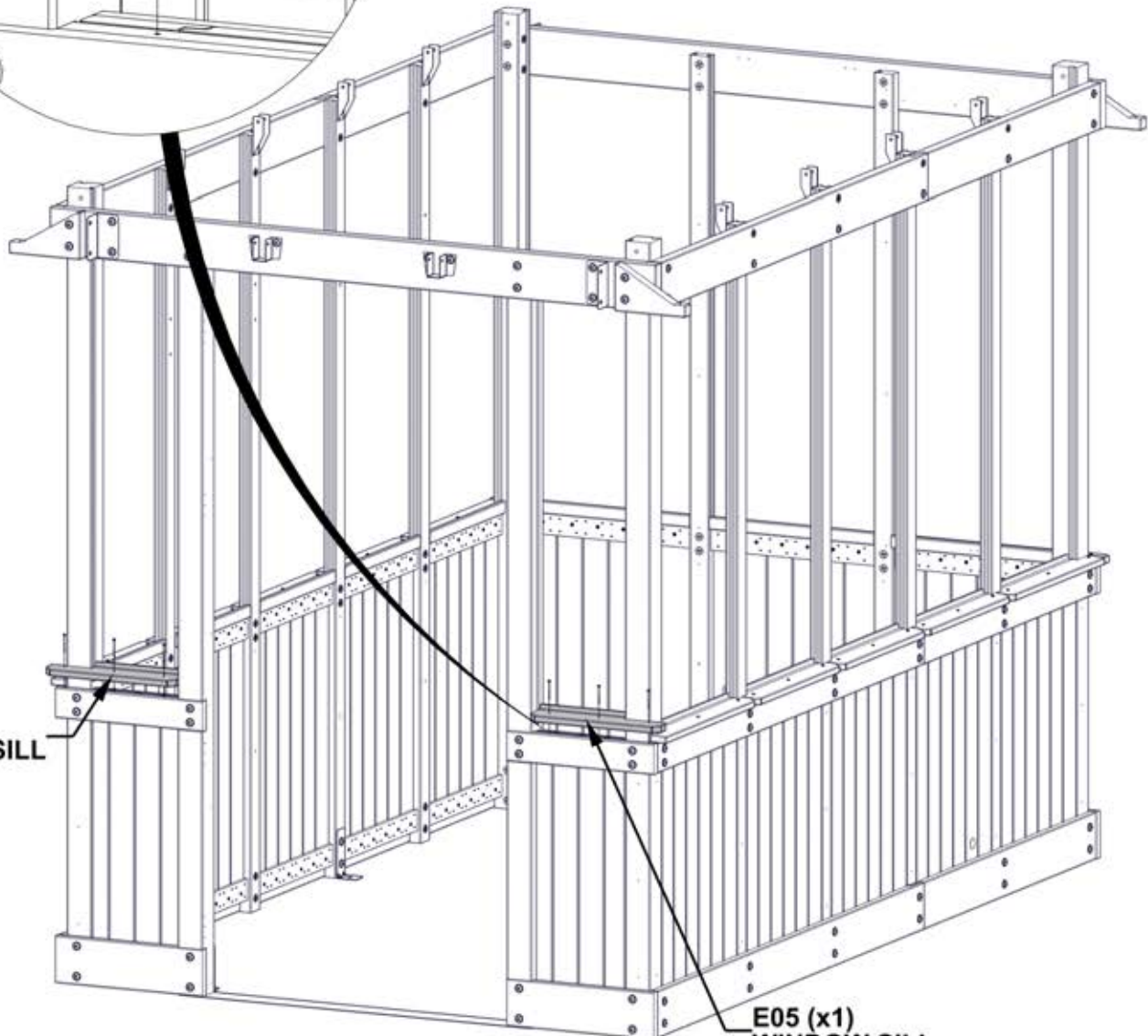

E04 (x1)  
WINDOW SILL

E05 (x1)  
WINDOW SILL

# STEP 31 - VENT ASSEMBLY

QTY	PART NUMBER	DESCRIPTION
6	H100392	SCREW PWH 8x3/4 BLK

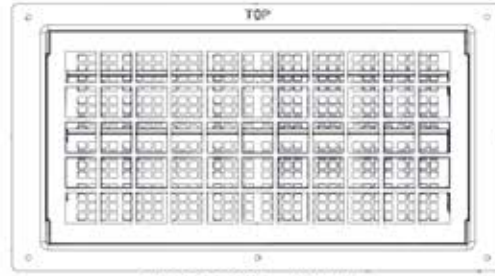

A6P00730 VENT  
(x1)

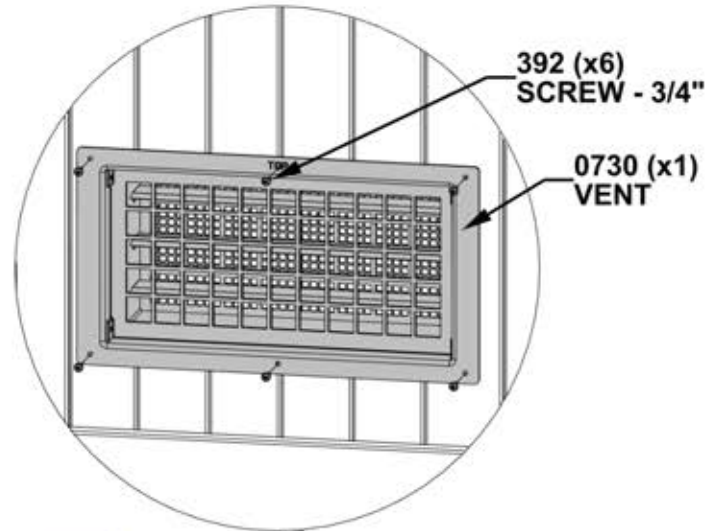

- SLIDE VENT INTO OPENING
- USE VENT FLANGE AS A GUIDE AND AN 1/8" [3mm] DRILL BIT TO CREATE PILOT HOLES INTO WALL PANEL
- DO NOT DRILL ALL THE WAY THROUGH THE WALL PANEL
- ATTACH AS SHOWN

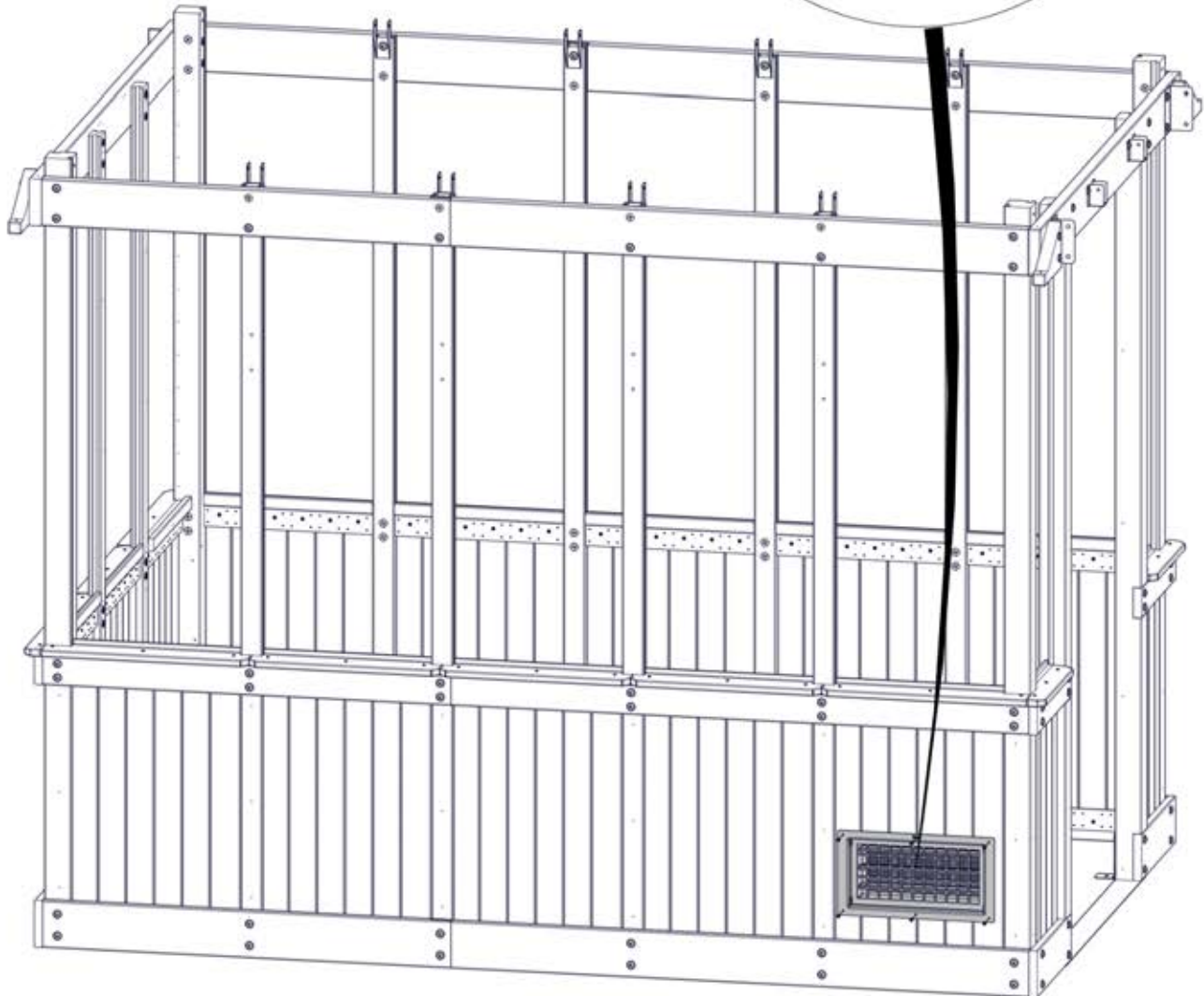

# STEP 32 - WINDOW ASSEMBLY

QTY	PART NUMBER	DESCRIPTION
2	H100391	SCREW PFH 8x2 BLK
2	H100627	SCREW PFH 6x3/4 BLK



WA03 WINDOW ASSEMBLY - W2A04330  
(x1) 1 7/8"x19 5/8"x47 3/16" (48x498x1198)



V01 LATCH BLOCK - W4L20099  
(x1) 1 1/4"x1 1/4"x3" (32x32x76)

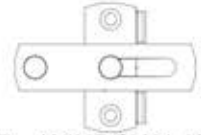

A4M02607 WINDOW LATCH LOCK  
(x1)

ALIGN TWO MIDDLE PILOT HOLES IN LATCH BLOCK WITH PILOT HOLES IN WINDOW ASSEMBLY AS SHOWN.

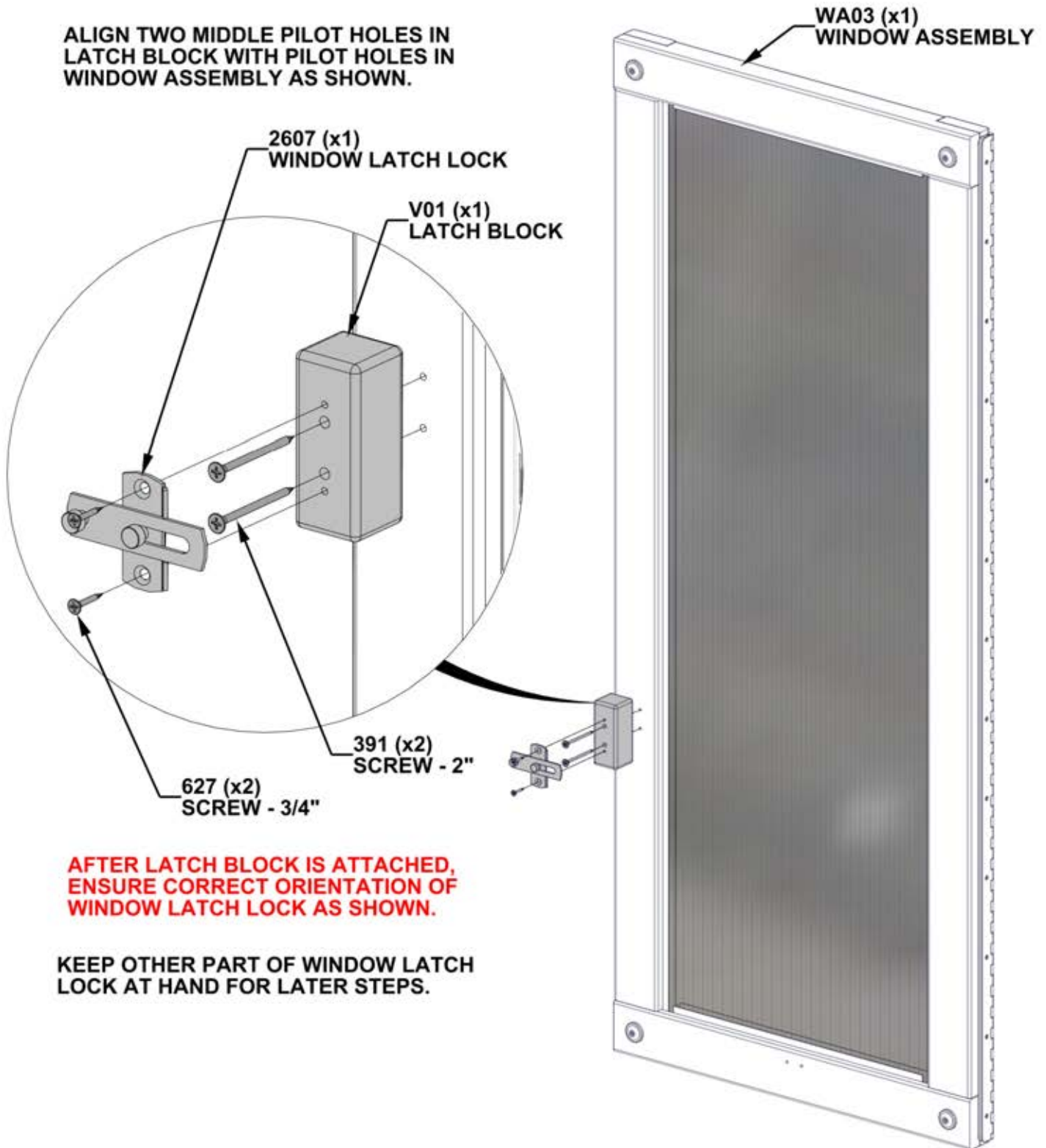

# STEP 33 - WINDOW ASSEMBLY

QTY	PART NUMBER	DESCRIPTION
13	H100385	SCREW PFH 8x1 BLK

WINDOW ASSEMBLY

385 (x13)  
SCREW - 1"

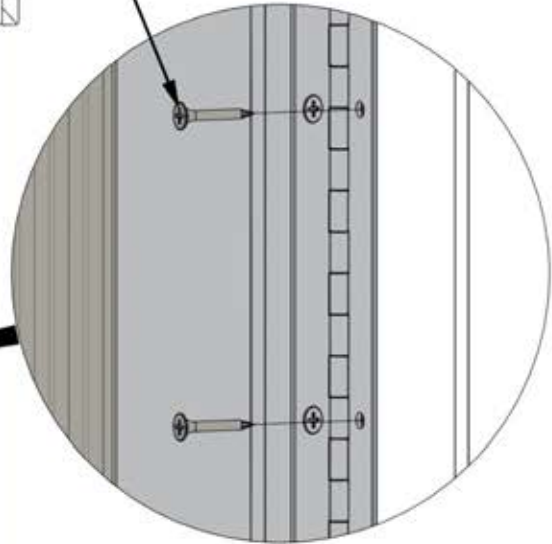

ATTACH WINDOW ASSEMBLY USING  
PILOT HOLES IN POST AS SHOWN.

ONLY BACK OF GREENHOUSE SHOWN FOR DETAIL.

# STEP 34 - WINDOW ASSEMBLY

QTY	PART NUMBER	DESCRIPTION
4	H100797	SCREW PWH 8x1 BLK

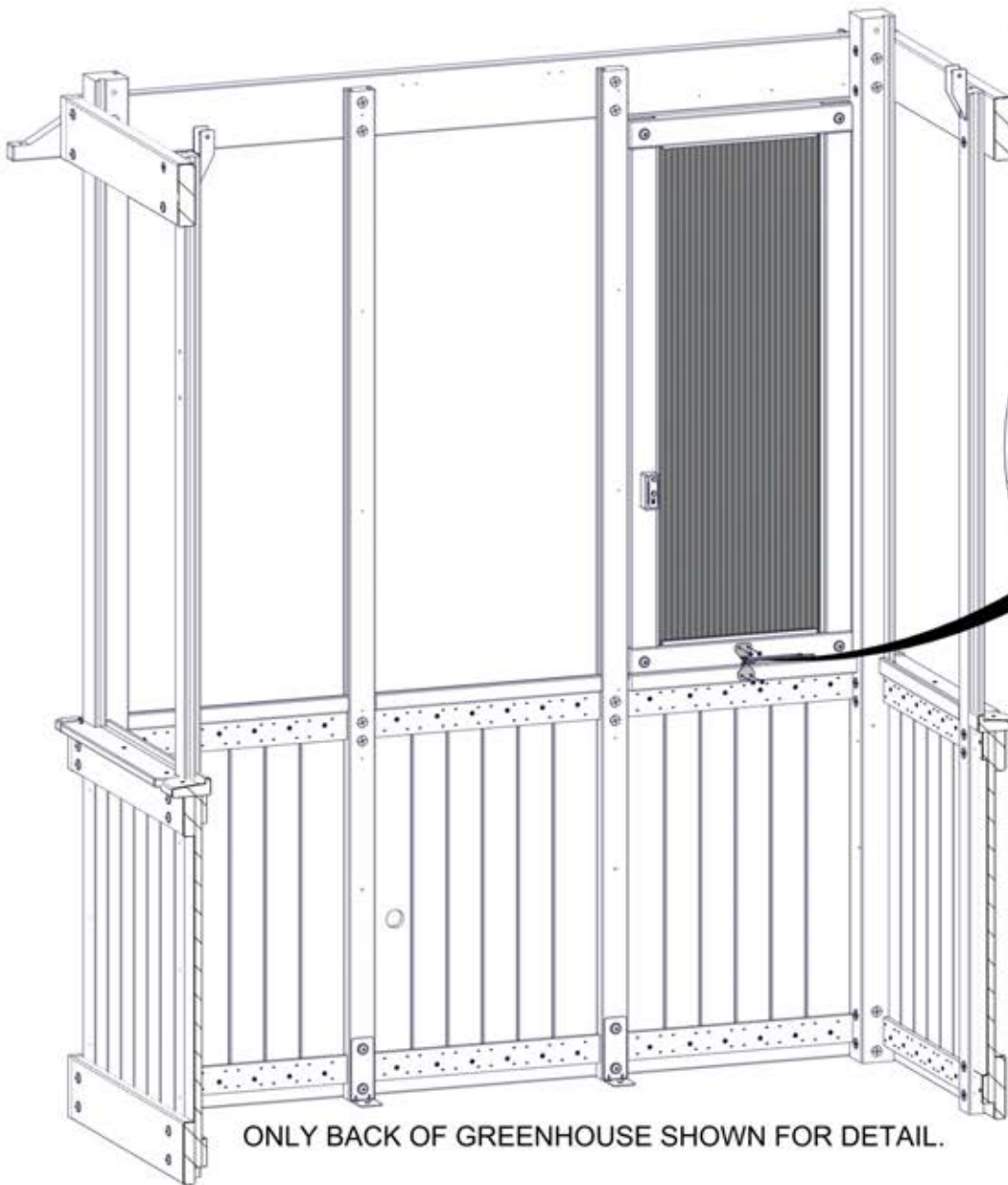
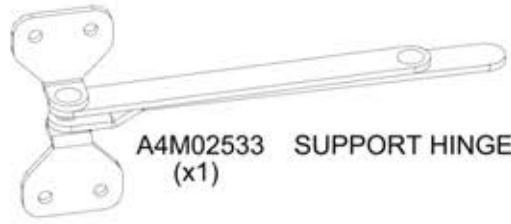

ATTACH SUPPORT HINGE USING PILOT HOLES IN WINDOW ASSEMBLY AND WINDOW SILL AS SHOWN.

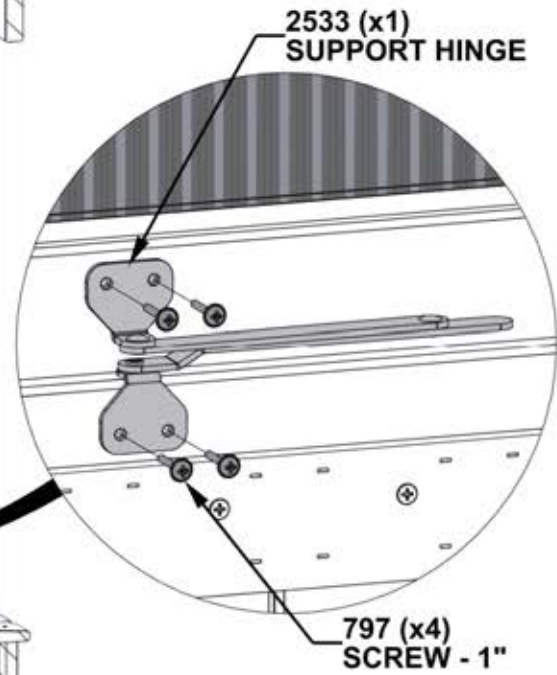

# STEP 35 - WINDOW ASSEMBLY

A6P00872 POLY CHANNEL  
(x4)

**REMOVE TAPE LINER ON POLY CHANNELS BEFORE INSTALLING.**

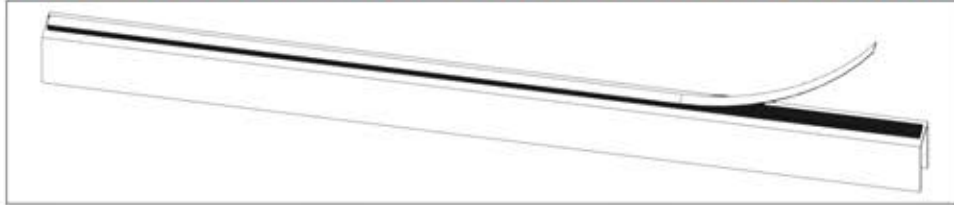

0872 (x4)  
POLY CHANNEL

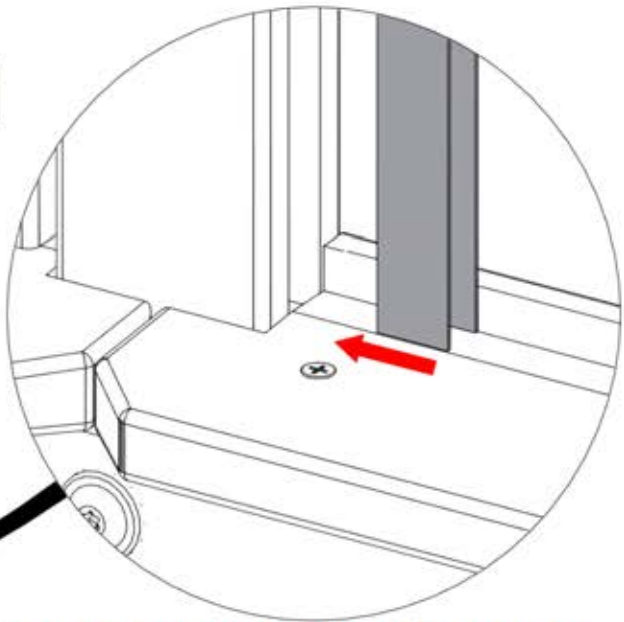

- INSERT POLY CHANNEL INTO GROOVE STARTING AT THE WINDOW SILL AND WORK UPWARDS.
- FIRMLY PRESS CHANNEL INTO GROOVE TO ENSURE TAPE ADHESION.

ONLY BACK OF GREENHOUSE  
SHOWN FOR DETAIL.

# STEP 36 - WINDOW ASSEMBLY



A6P00924 POLY SHEET  
(x2)



A6P00925 POLY CHANNEL  
(x4)



A6P00690 DUST SEAL TAPE

## TO APPLY DUST SEAL TAPE AND POLY CHANNEL:

- CUT 2 STRIPS OF DUST SEAL TAPE THE SAME WIDTH AS THE POLY SHEET.
- WRAP DUST SEAL TAPE ALONG EDGE OF POLY SHEET WIDTH.
- AFTER TAPE IS SECURE, PUSH CHANNEL ON OVER THE TAPE, CENTERING ON THE POLY SHEET.
- REPEAT ON THE BOTTOM SIDE OF POLY SHEET.
- **REPEAT FOR BOTH WINDOW ASSEMBLIES.**

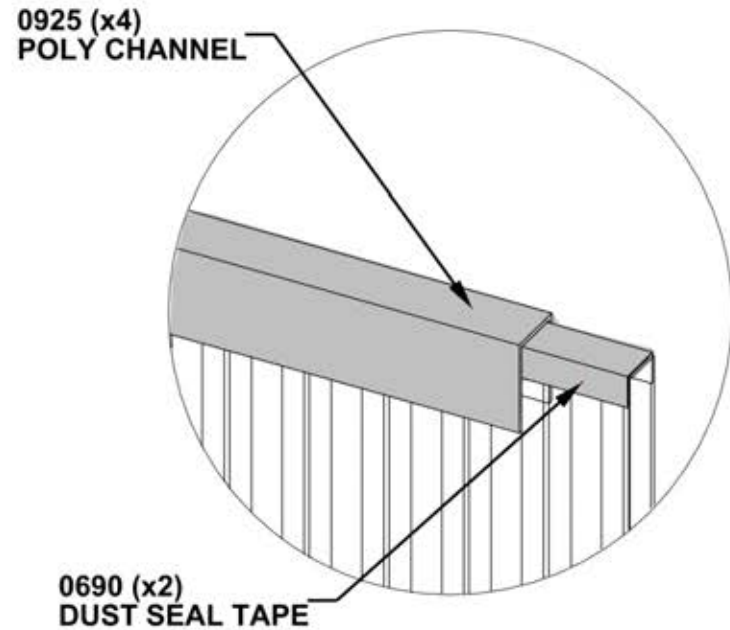

0925 (x4)  
POLY CHANNEL

0690 (x2)  
DUST SEAL TAPE

0924 (x2)  
POLY SHEET



# STEP 37 - WINDOW ASSEMBLY

## IMPORTANT!

- ENSURE UV SIDE OF WINDOW IS FACING OUTSIDE.
- ONCE WINDOW IS INSTALLED, IT IS SAFE TO REMOVE THE PROTECTIVE FILM.

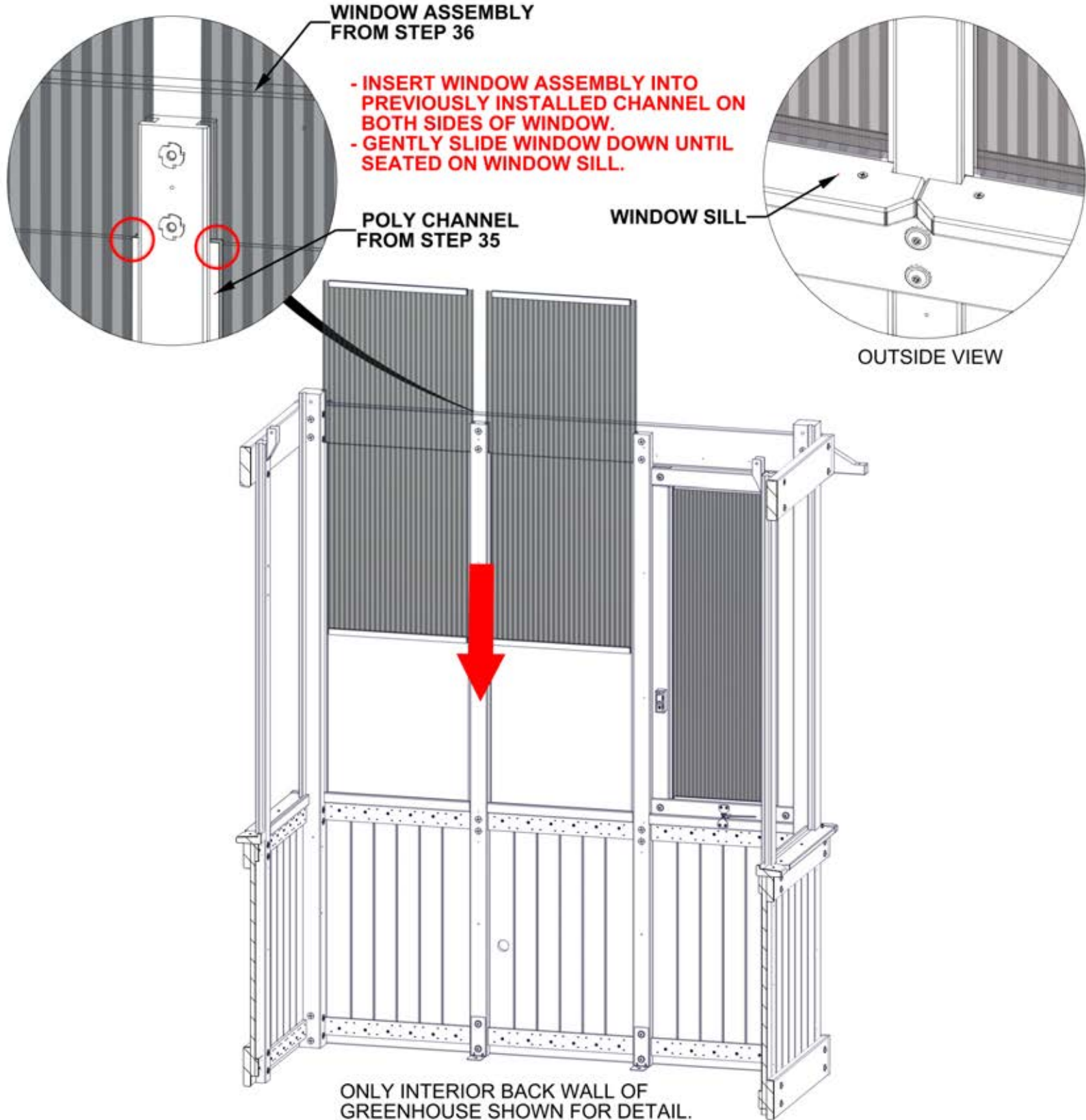

# STEP 38 - WINDOW ASSEMBLY

QTY	PART NUMBER	DESCRIPTION
4	H100391	SCREW PFH 8x2 BLK



P05 WINDOW CAP - W4L20090  
(x2) 1 7/16"x1 7/16"x19 7/8" (36x36x505)

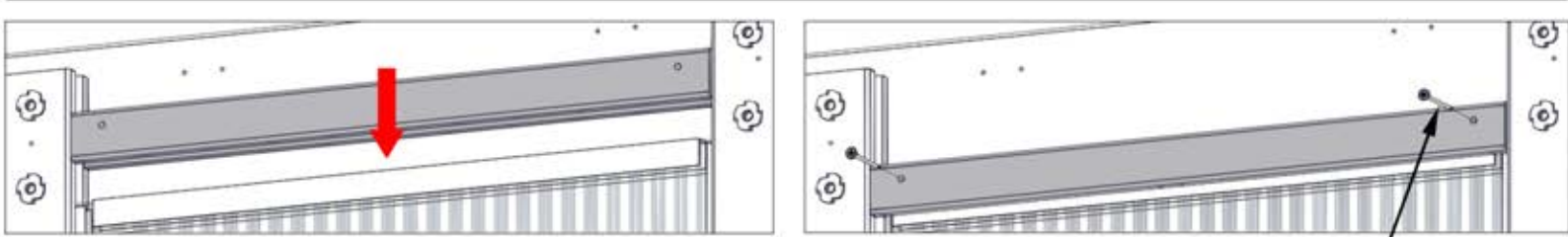

SLIDE GROOVE IN WINDOW CAP OVER WINDOW ASSEMBLY THEN SCREW INTO PLACE.

391 (x4)  
SCREW - 2"

P05 (x2)  
WINDOW CAP

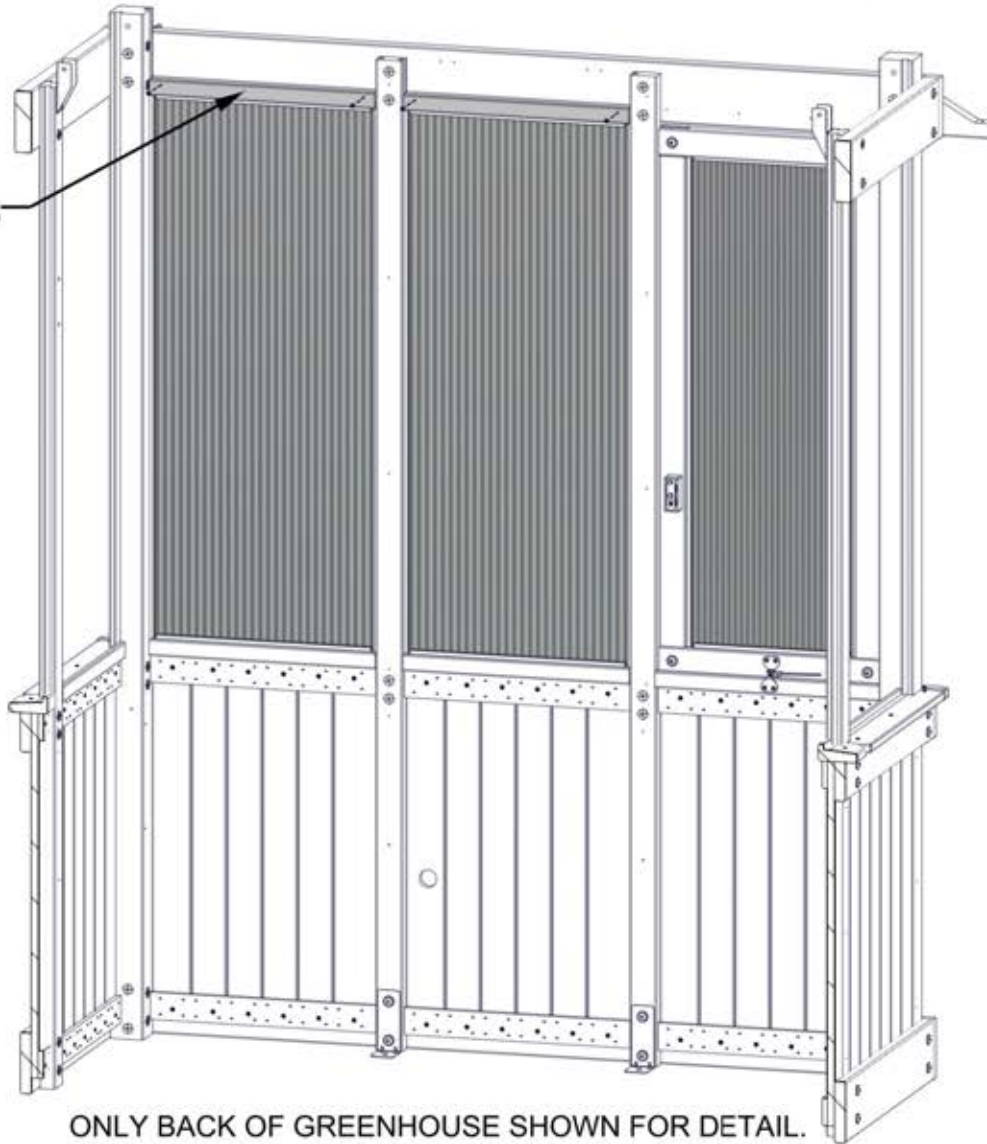

ONLY BACK OF GREENHOUSE SHOWN FOR DETAIL.

# STEP 39 - BACK WALL ASSEMBLY

QTY	PART NUMBER	DESCRIPTION
4	H100391	SCREW PFH 8x2 BLK



F11 WINDOW FRAME - W4L20087  
(x1) 1 7/16"x2 3/8"x20" (36x60x508)

ALIGN PILOT HOLES  
IN F11 WITH PILOT  
HOLES IN HEADER.

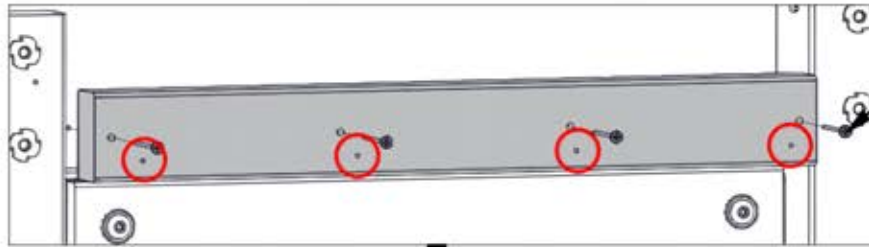

391 (x4)  
SCREW - 2"

**NOTE PILOT HOLES IN F11  
FOR CORRECT ORIENTATION.**

F11 (x1)  
WINDOW FRAME

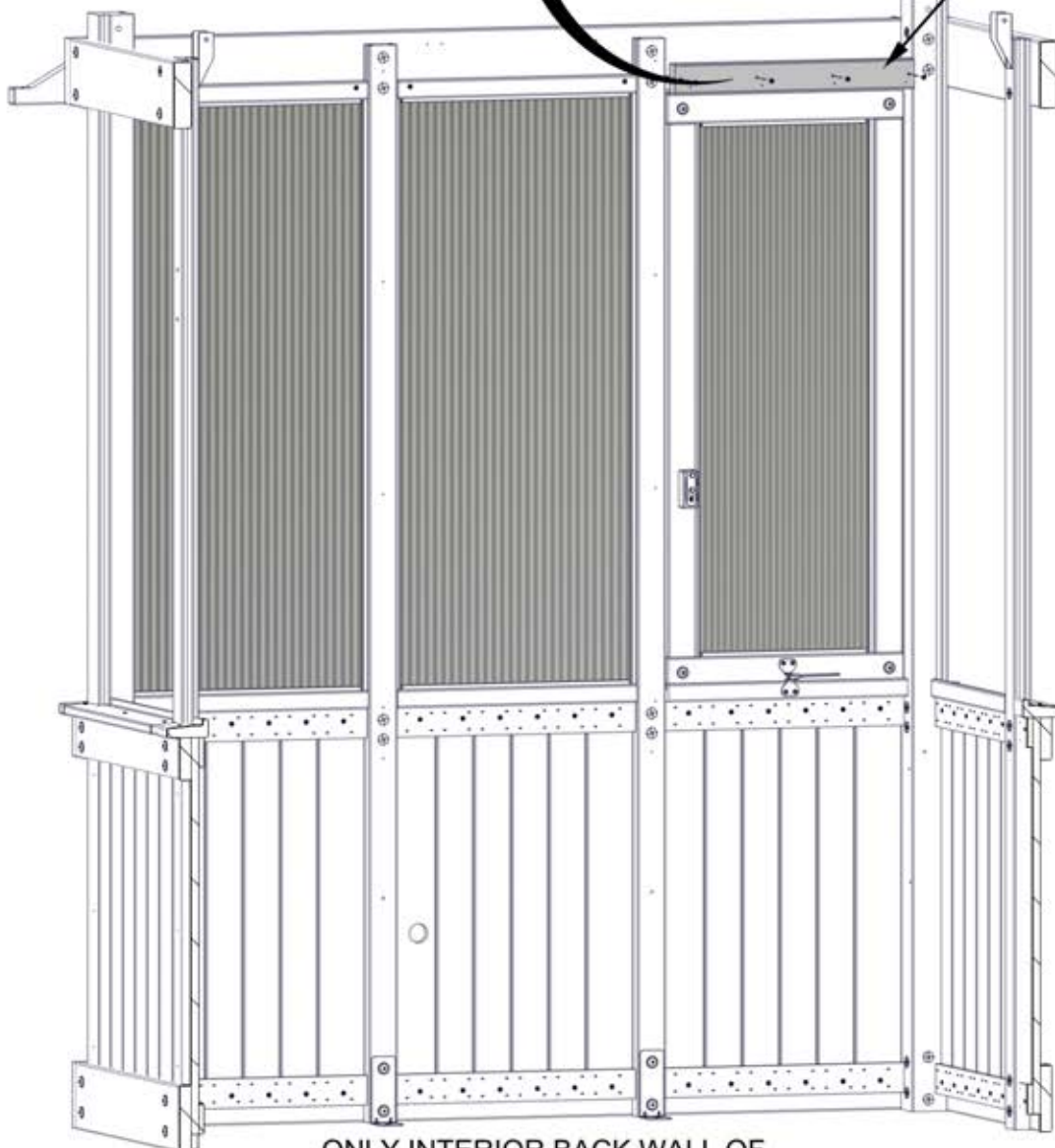

ONLY INTERIOR BACK WALL OF  
GREENHOUSE SHOWN FOR DETAIL.

# STEP 40 - BACK WALL ASSEMBLY

QTY	PART NUMBER	DESCRIPTION
4	H100200	SCREW PFH 8x1 1/2 BLK

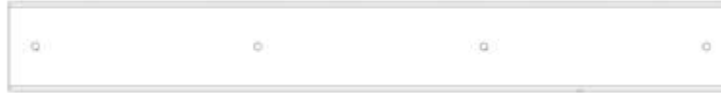

N05 WINDOW TRIM - W4L20086  
(x1) 5/8"x2 3/8"x19 3/8" (16x60x492)

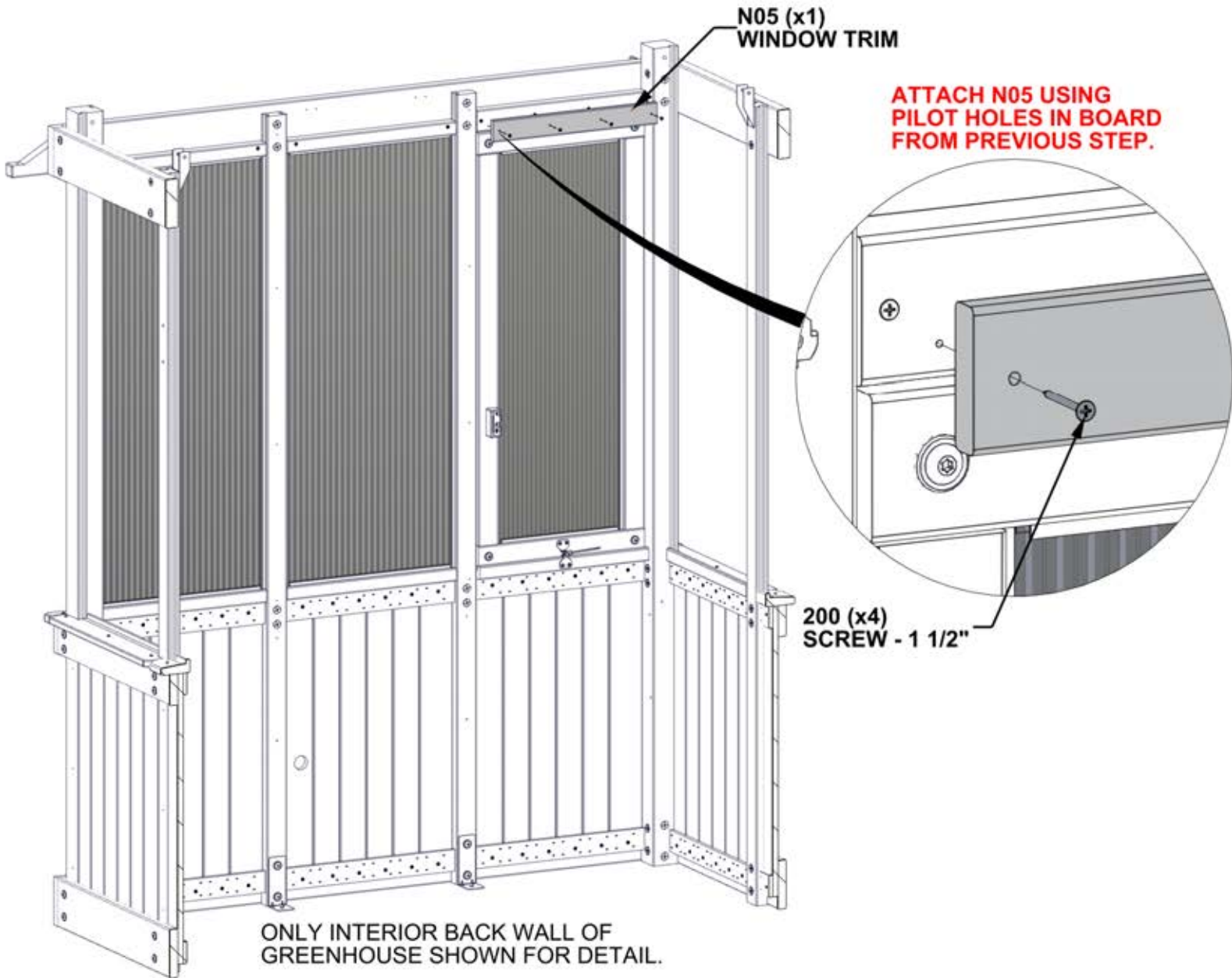

# STEP 41 - BACK WALL ASSEMBLY

QTY	PART NUMBER	DESCRIPTION
8	H100200	SCREW PFH 8x1 1/2 BLK

CB01 SLAT FRAME - W4L20088  
(x1) 5/8"x3"x53 7/8" (16x76x1368)

N07 SLAT FRAME - W4L20094  
(x1) 5/8"x2 3/8"x53 7/8" (16x60x1368)

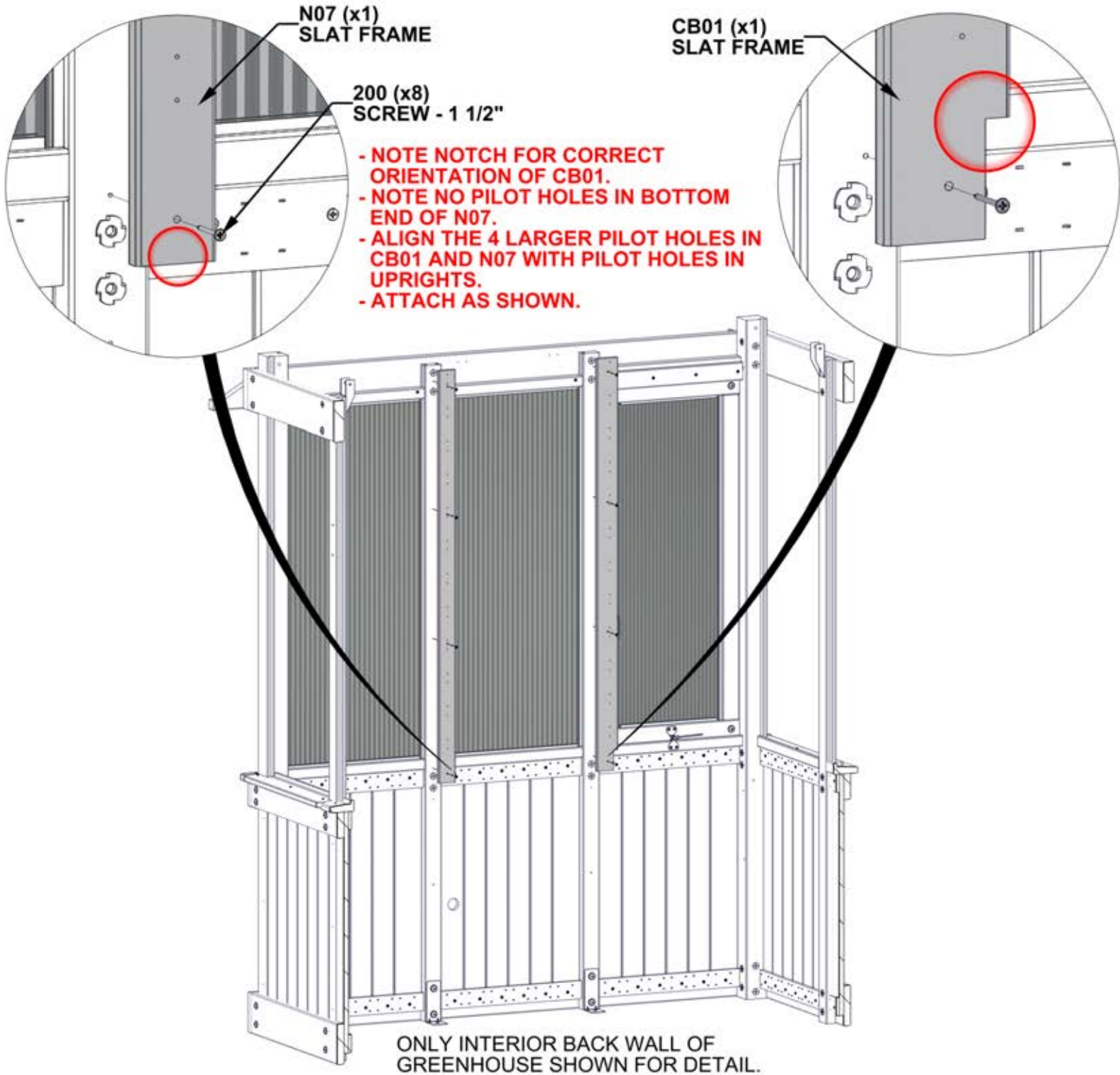

# STEP 42 - BACK WALL ASSEMBLY

QTY	PART NUMBER	DESCRIPTION
44	H100380	SCREW PFH 8x1 1/8 BLK



N06 SLAT - W4L20089  
(x11) 5/8"x2 3/8"x25 3/8" (16x60x645)

STARTING FROM THE BOTTOM, ALIGN 11 SLAT BOARDS WITH PILOT HOLES ON UPRIGHTS AND ATTACH AS SHOWN.

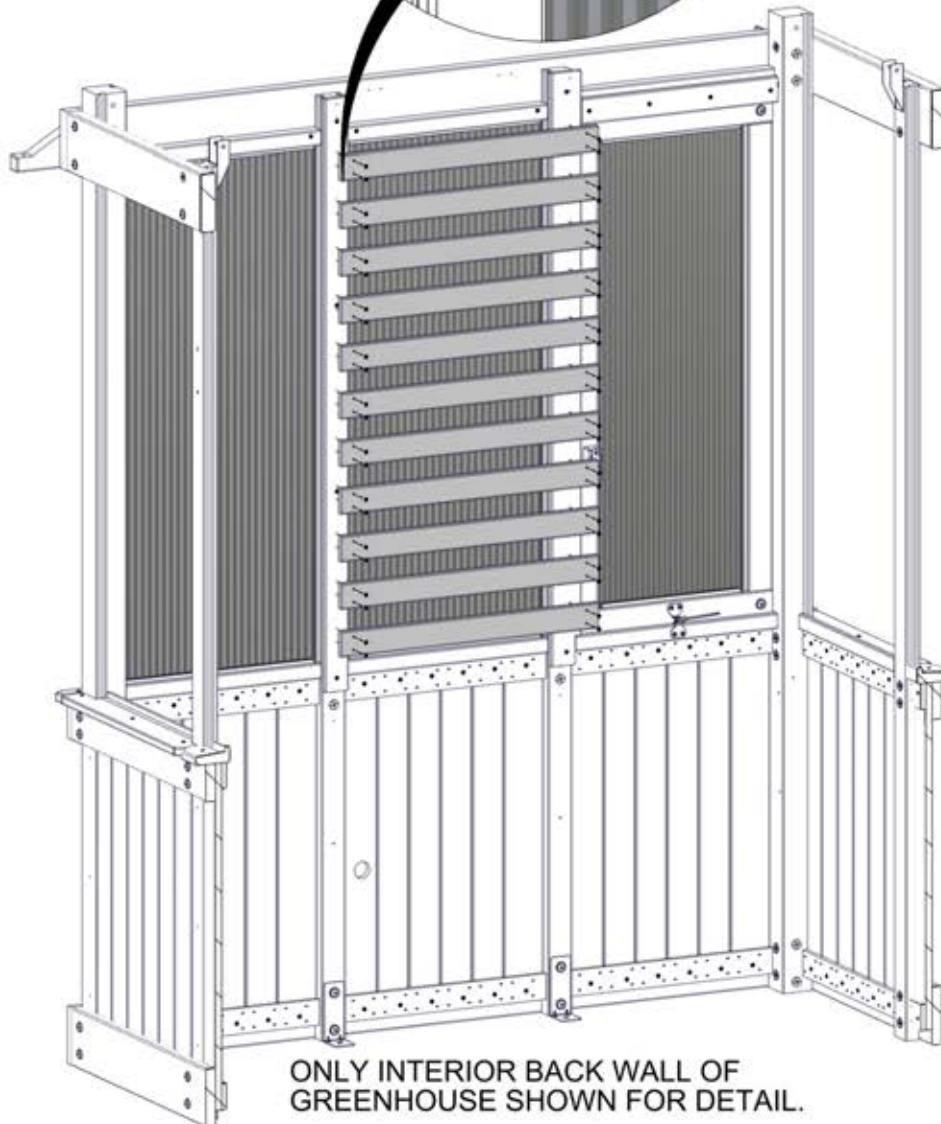
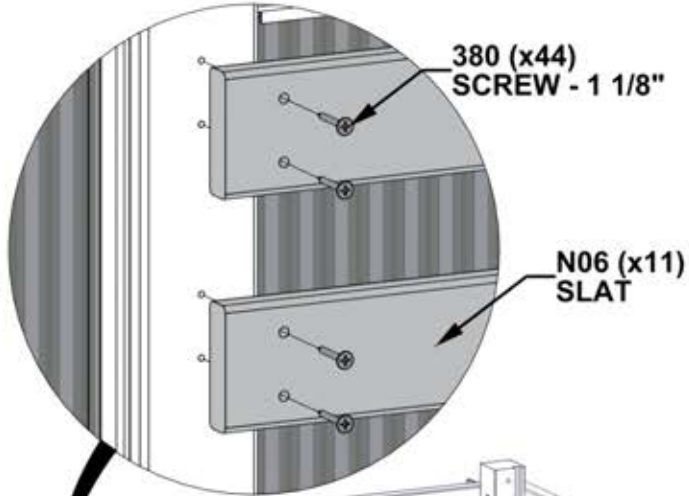

ONLY INTERIOR BACK WALL OF GREENHOUSE SHOWN FOR DETAIL.

# STEP 43 - BACK WALL ASSEMBLY

QTY	PART NUMBER	DESCRIPTION
2	H100627	SCREW PFH 6x3/4 BLK

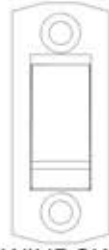

A4M02607 (x1) WINDOW LATCH LOCK (SET ASIDE IN STEP 32)

**WITH WINDOW CLOSED, ALIGN LATCH LOCK AS SHOWN. MARK HOLE LOCATIONS AND PRE-DRILL WITH 1/8" [3mm] DRILL BIT.**

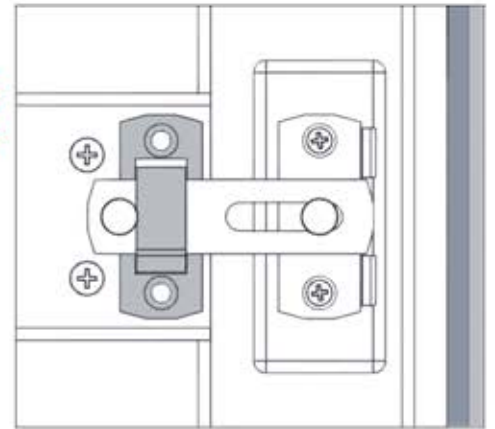

**ATTACH LATCH LOCK USING PRE-DRILLED HOLES.**

627 (x2)  
SCREW - 3/4"

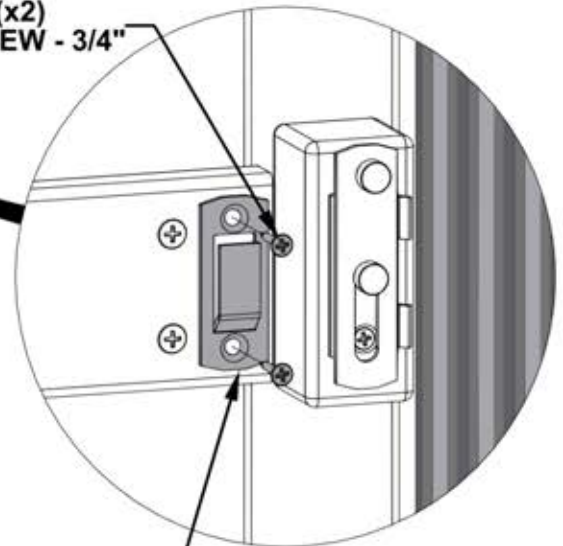

ONLY INTERIOR BACK WALL OF GREENHOUSE SHOWN FOR DETAIL.

2607 (x1)  
WINDOW LATCH LOCK

# STEP 44 - TABLE ASSEMBLY

QTY	PART NUMBER	DESCRIPTION
2	H100201	SCREW PFH 8x2 1/2 BLK
2	H100460	LAG SCREW WH 1/4x1 BLK
2	H100536	SCREW PWH 8x1 1/4 BLK

P04 TABLE CLEAT - W4L20084  
 (x1) 1 7/16"x1 7/16"x64 13/16" (36x36x1646)



A4M00555 L BRACKET BLK  
 (x2)

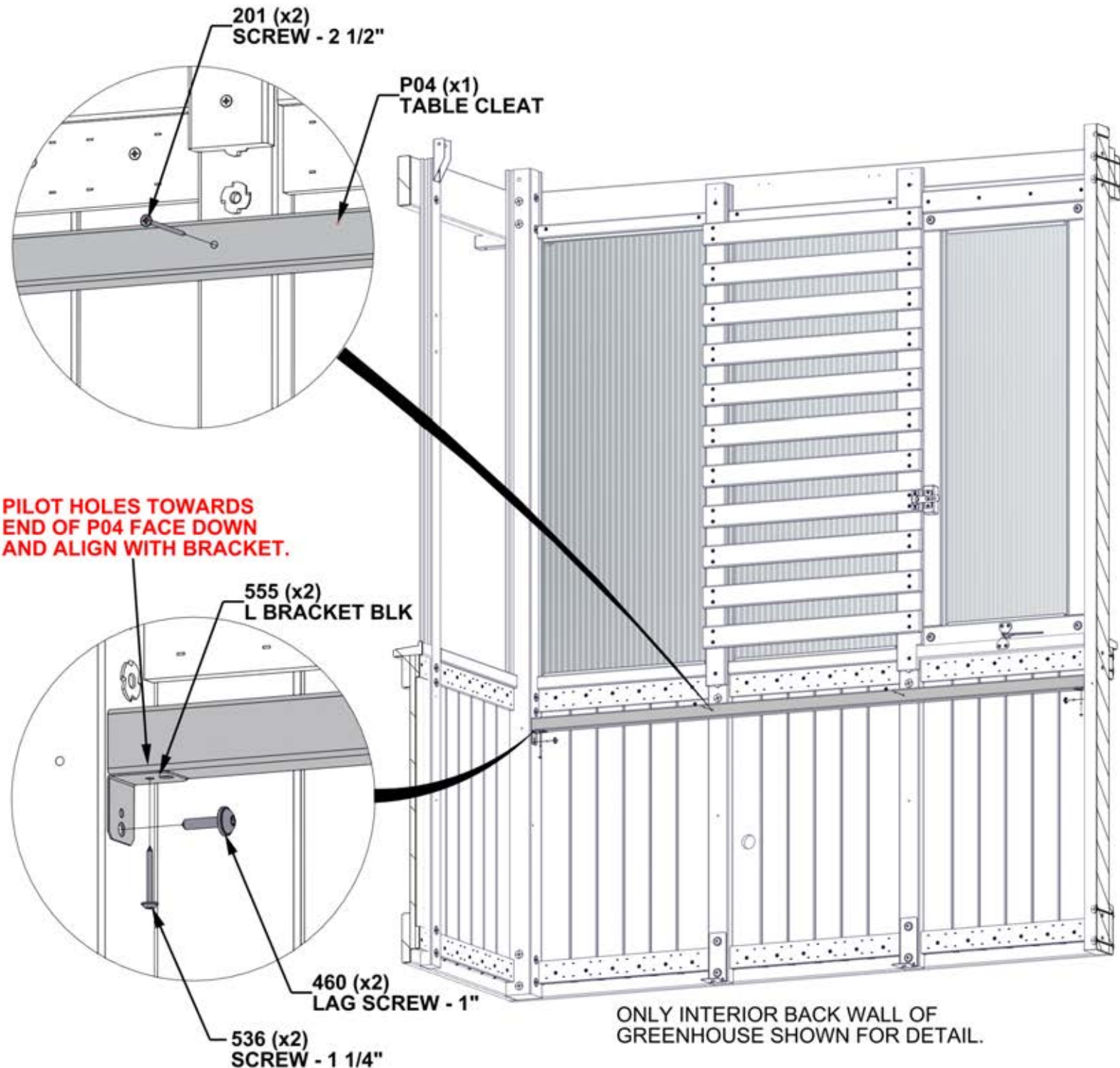

# STEP 45 - TABLE ASSEMBLY

QTY	PART NUMBER	DESCRIPTION
5	H100200	SCREW PFH 8x1 1/2 BLK
2	H100536	SCREW PWH 8x1 1/4 BLK

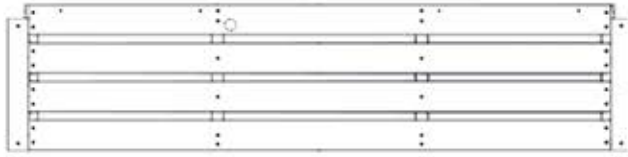

TB02 TABLE ASSEMBLY - W2A04331  
(x1) 2 1/16"x16 1/16"x68 11/16" (52x408x1744)



M03 TABLE TRIM - W4L20085  
(x1) 5/8"x3 3/8"x68 11/16" (16x86x1744)



A4M00555 L BRACKET BLK  
(x2)

ALIGN PILOT HOLES AND ATTACH TRIM AND BRACKETS TO TABLE ASSEMBLY AS SHOWN.

**TOP OF M03 IS FLUSH WITH TABLE TOP.**

555 (x2)  
L BRACKET BLK

**DO NOT FULLY TIGHTEN SCREWS ON BRACKETS.**

200 (x5)  
SCREW - 1 1/2"

536 (x2)  
SCREW - 1 1/4"

M03 (x1)  
TABLE TRIM

TB02 (x1)  
TABLE ASSEMBLY

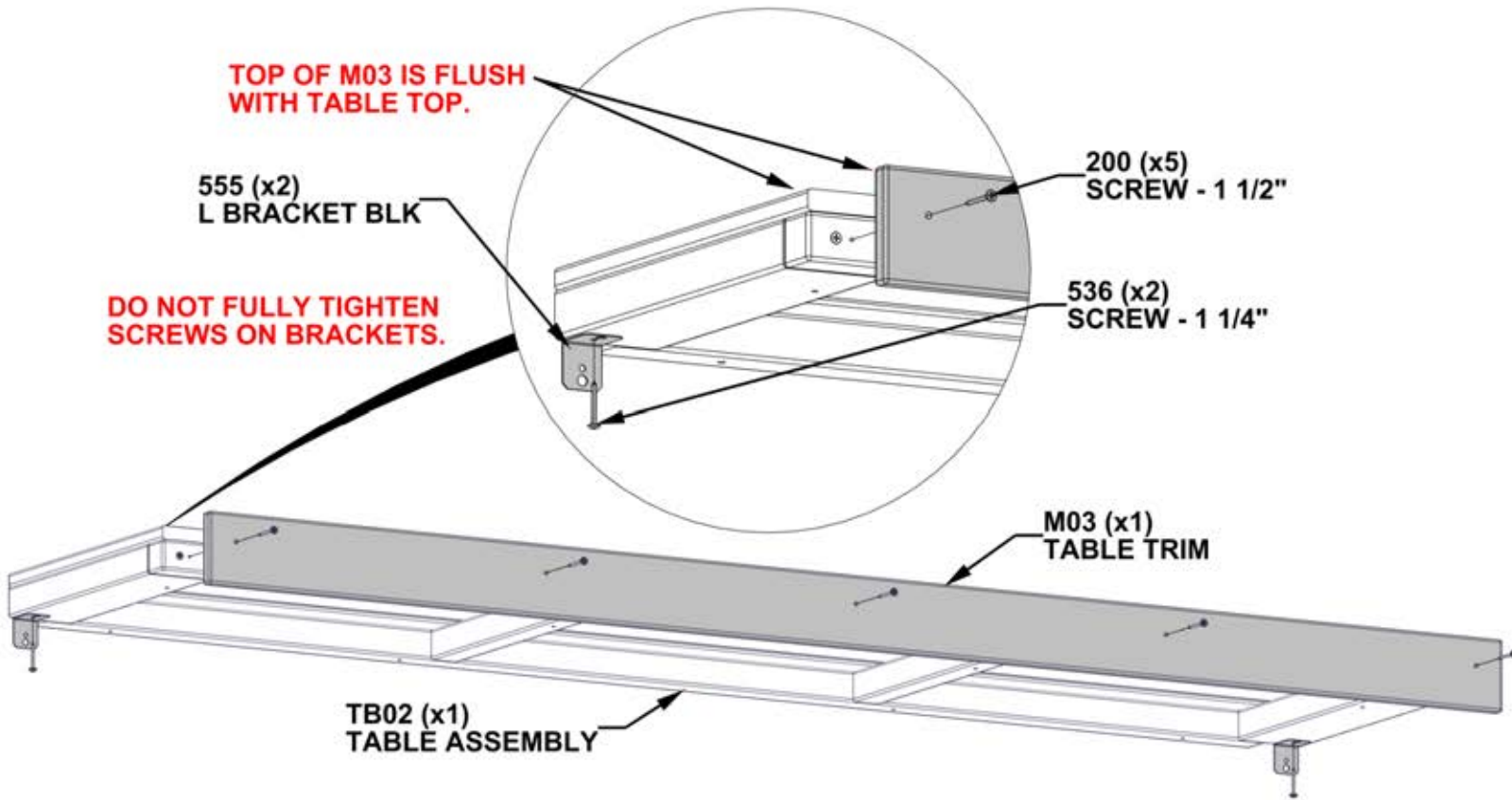

# STEP 46 - TABLE ASSEMBLY

QTY	PART NUMBER	DESCRIPTION
4	H100362	SCREW PFH 8x3 BLK
2	H100460	LAG SCREW WH 1/4x1 BLK



TABLE ASSEMBLY - FROM STEP 45

**DO NOT LEAN ON OR PUT ANY WEIGHT ON TABLE UNTIL ANGLE BRACES ARE INSTALLED IN NEXT STEPS.**

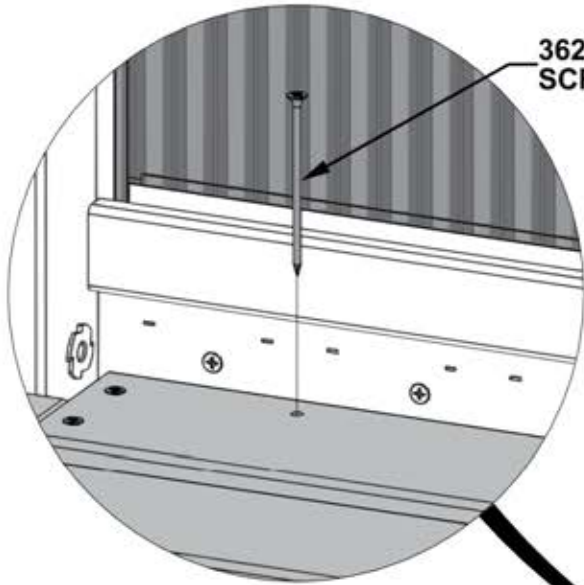

362 (x4)  
SCREW - 3"

**ATTACH TABLE ASSEMBLY AS SHOWN.**

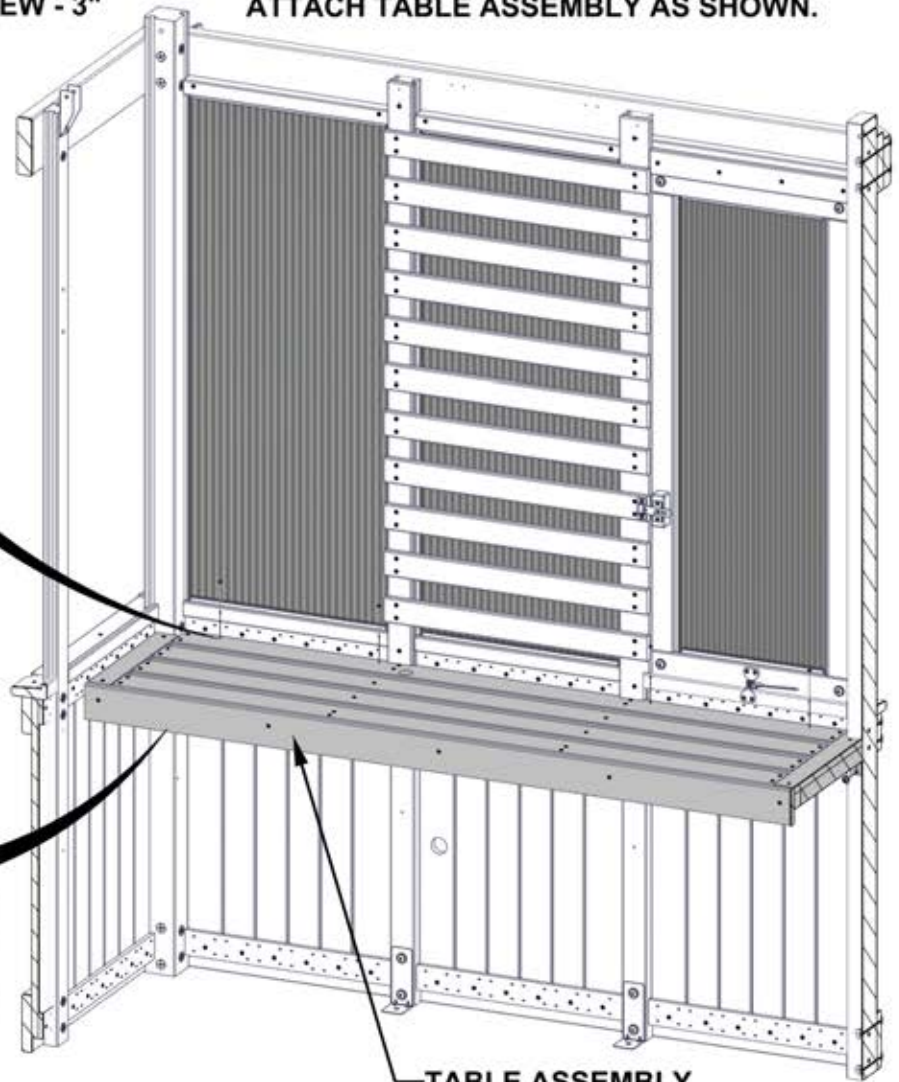
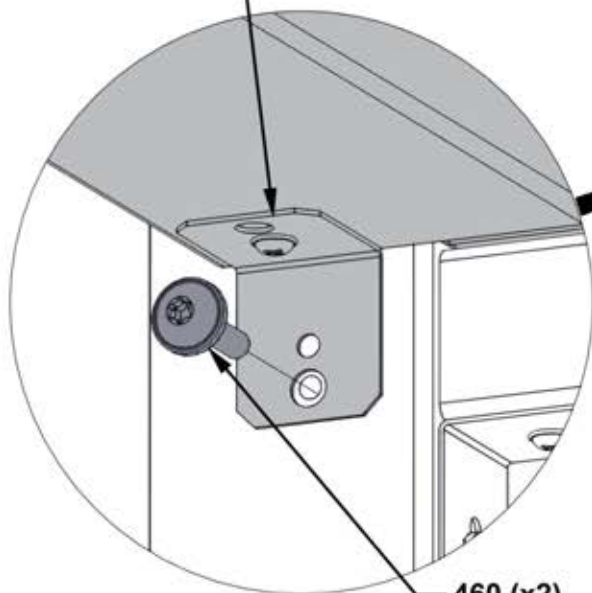

TABLE ASSEMBLY

**ONCE LAG SCREWS ARE ATTACHED, FULLY TIGHTEN SCREWS ON BRACKETS.**



460 (x2)  
LAG SCREW - 1"

ONLY INTERIOR BACK WALL OF GREENHOUSE SHOWN FOR DETAIL.

HAVE A SECOND PERSON HOLD TABLE IN PLACE UNTIL ANGLE BRACES ARE INSTALLED IN NEXT STEP.

# STEP 47 - TABLE ASSEMBLY

QTY	PART NUMBER	DESCRIPTION
8	H100405	WASHER LOCK EXT 6x15
8	H100456	LAG SCREW WH 1/4x2 1/2 BLK



F02 ANGLE BRACE - W4L20039  
(x2) 1 7/16"x2 3/8"x18 1/16" (36x60x458)



F03 ANGLE BRACE - W4L20040  
(x2) 1 7/16"x2 3/8"x18 1/16" (36x60x458)

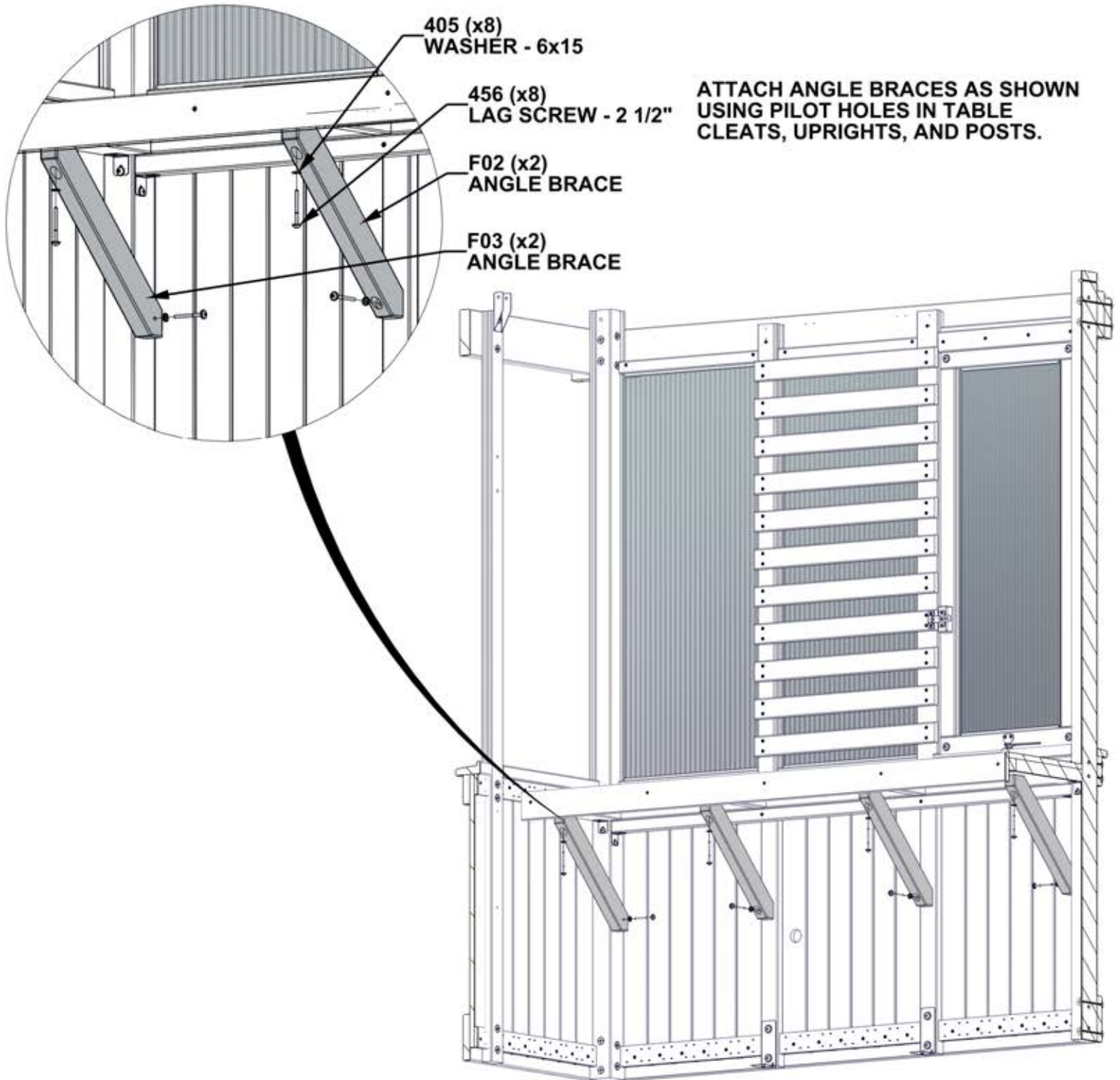

**ATTACH ANGLE BRACES AS SHOWN USING PILOT HOLES IN TABLE CLEATS, UPRIGHTS, AND POSTS.**

**ONLY INTERIOR BACK WALL OF GREENHOUSE SHOWN FOR DETAIL.**

# STEP 48 - TABLE ASSEMBLY

QTY	PART NUMBER	DESCRIPTION
4	H100201	SCREW PFH 8x2 1/2 BLK
1	H100460	LAG SCREW WH 1/4x1 BLK
1	H100536	SCREW PWH 8x1 1/4 BLK



P06 TABLE CLEAT - W4L20095  
(x1) 1 7/16"x1 7/16"x87 3/8" (36x36x2220)



A4M00555 L BRACKET BLK  
(x1)

**PILOT HOLE TOWARDS END OF P06 FACES DOWN AND ALIGN WITH BRACKET.**

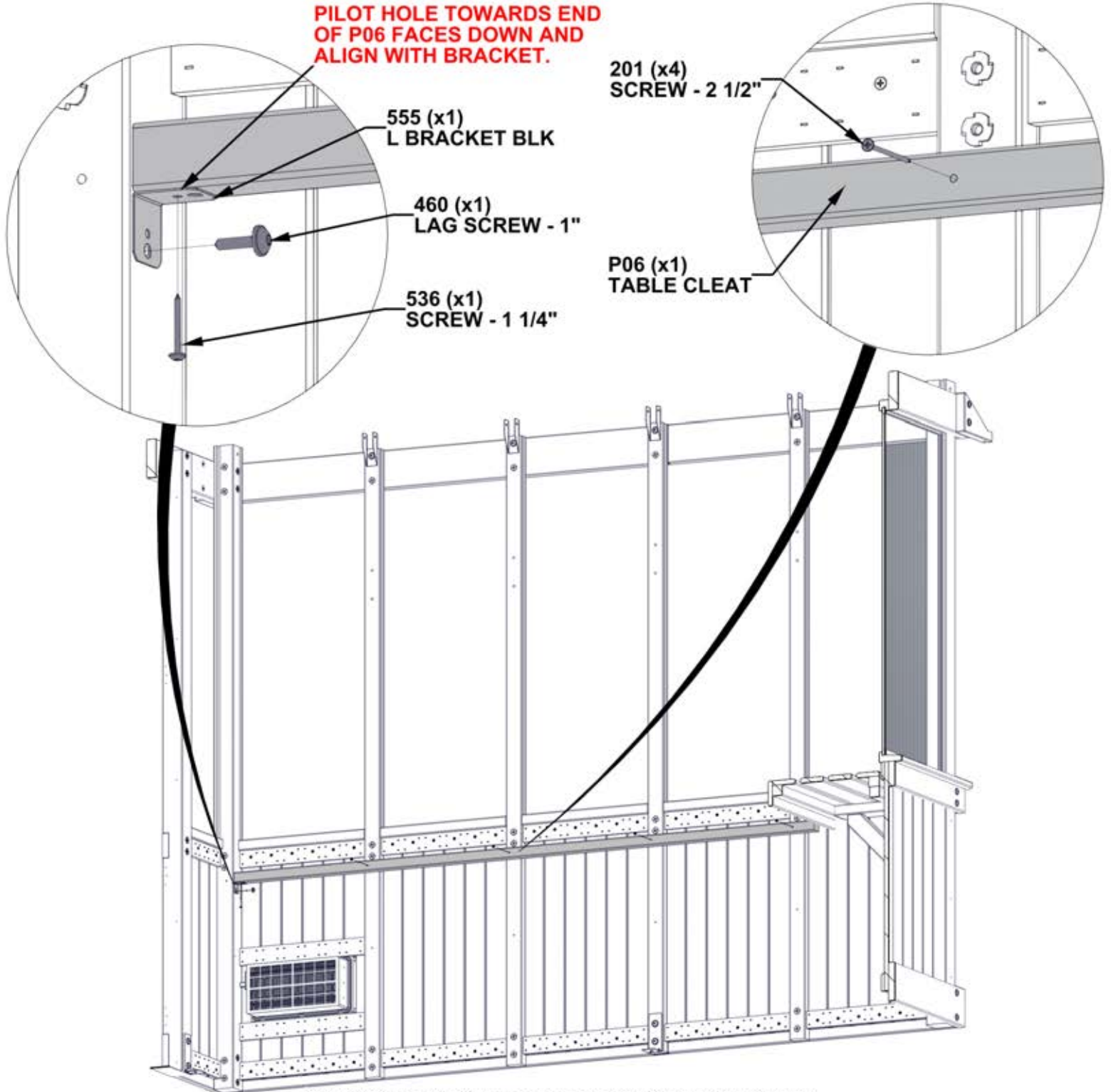

ONLY SIDE OF GREENHOUSE SHOWN FOR DETAIL.

# STEP 49 - TABLE ASSEMBLY

QTY	PART NUMBER	DESCRIPTION
6	H100201	SCREW PFH 8x2 1/2 BLK
12	H100387	SCREW PFH 8x1 1/4 BLK

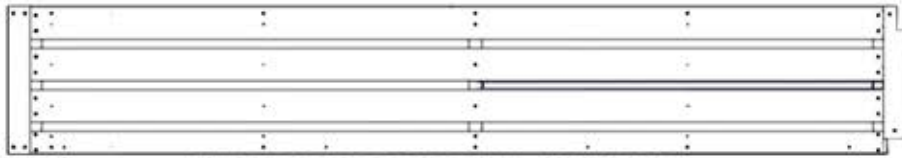

TB01 TABLE ASSEMBLY - W2A04325  
(x1) 2 1/16"x14 7/8"x89 1/2" (52x378x2274)



P01 TABLE CLEAT - W4L20036  
(x3) 1 7/16"x1 7/16"x11 13/16" (36x36x300)

**PAY CLOSE ATTENTION TO PILOT HOLES FOR CORRECT INSTALLATION.**

FIRST, ATTACH P01 BOARDS TO TABLE ASSEMBLY AS SHOWN.

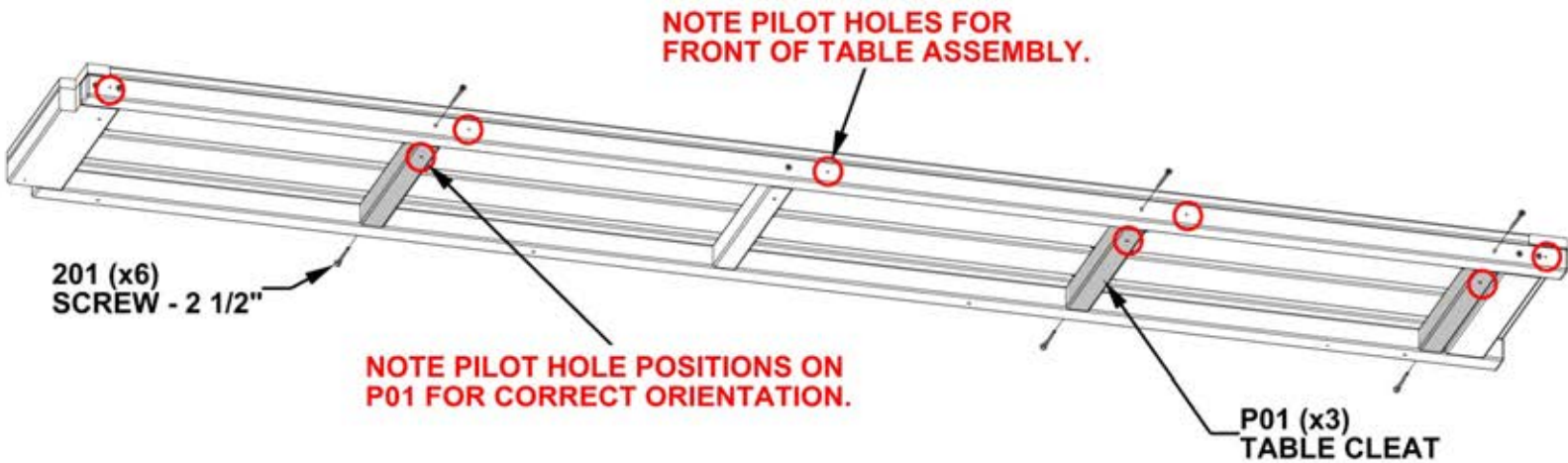

SECOND, INSTALL SCREWS THROUGH PILOT HOLES ON TABLE TOP INTO TABLE CLEATS AS SHOWN.

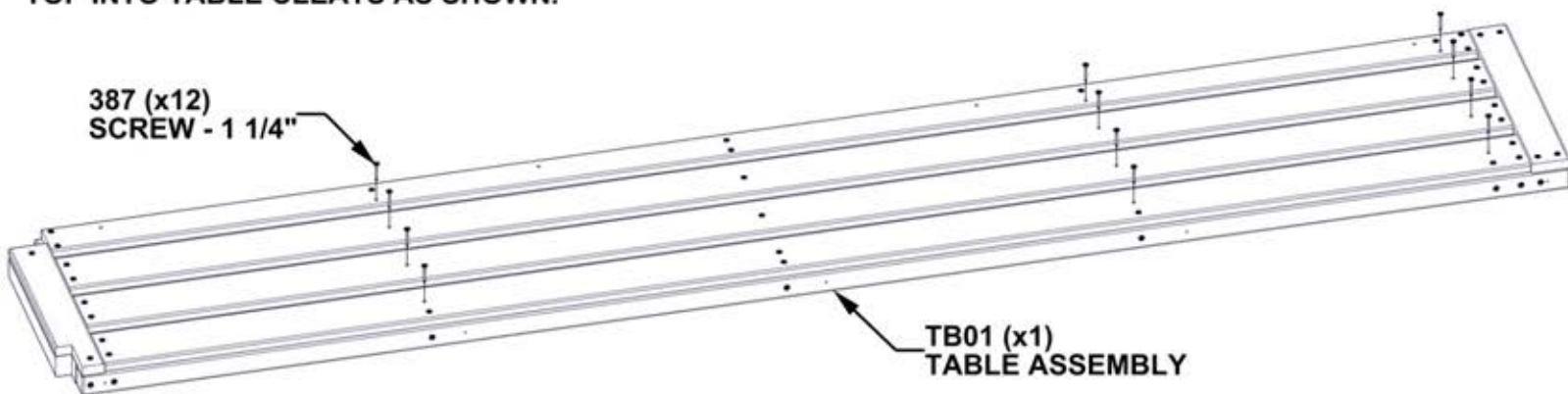

# STEP 50 - TABLE ASSEMBLY

QTY	PART NUMBER	DESCRIPTION
5	H100200	SCREW PFH 8x1 1/2 BLK
1	H100536	SCREW PWH 8x1 1/4 BLK



M01 TABLE TRIM - W4L20037  
 (x1) 5/8"x3 3/8"x89 1/2" (16x86x2274)



A4M00555 L BRACKET BLK  
 (x1)

ALIGN PILOT HOLES AND ATTACH TRIM AND BRACKETS TO TABLE ASSEMBLY AS SHOWN.

TOP OF M01 IS FLUSH WITH TABLE TOP.

200 (x5)  
 SCREW - 1 1/2"

555 (x1)  
 L BRACKET BLK

DO NOT FULLY TIGHTEN SCREWS ON BRACKETS.

536 (x1)  
 SCREW - 1 1/4"

M01 (x1)  
 TABLE TRIM

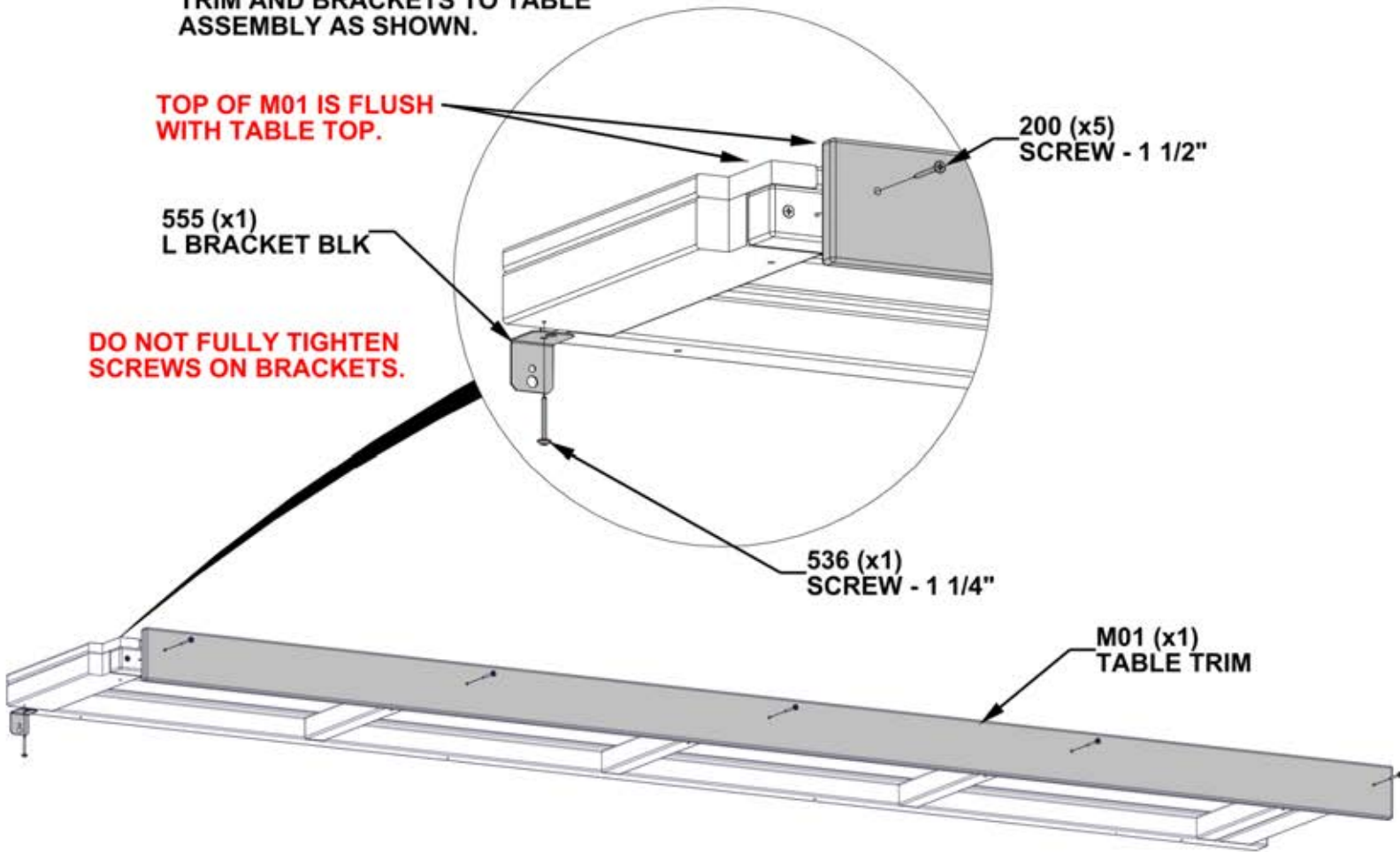

# STEP 51 - TABLE ASSEMBLY

QTY	PART NUMBER	DESCRIPTION
4	H100362	SCREW PFH 8x3 BLK
1	H100460	LAG SCREW WH 1/4x1 BLK

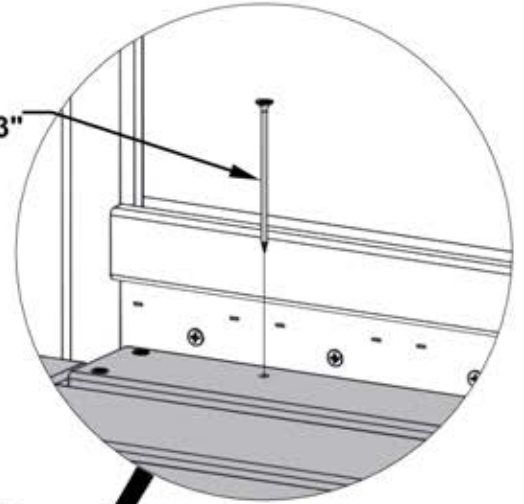

TABLE ASSEMBLY - FROM STEPS 49 & 50

**DO NOT LEAN ON OR PUT ANY WEIGHT ON TABLE UNTIL ANGLE BRACES ARE INSTALLED IN NEXT STEPS.**

ATTACH TABLE ASSEMBLY AS SHOWN.

362 (x4)  
SCREW - 3"



460 (x1)  
LAG SCREW - 1"



**ONCE LAG SCREWS ARE ATTACHED, FULLY TIGHTEN SCREWS ON BRACKETS.**

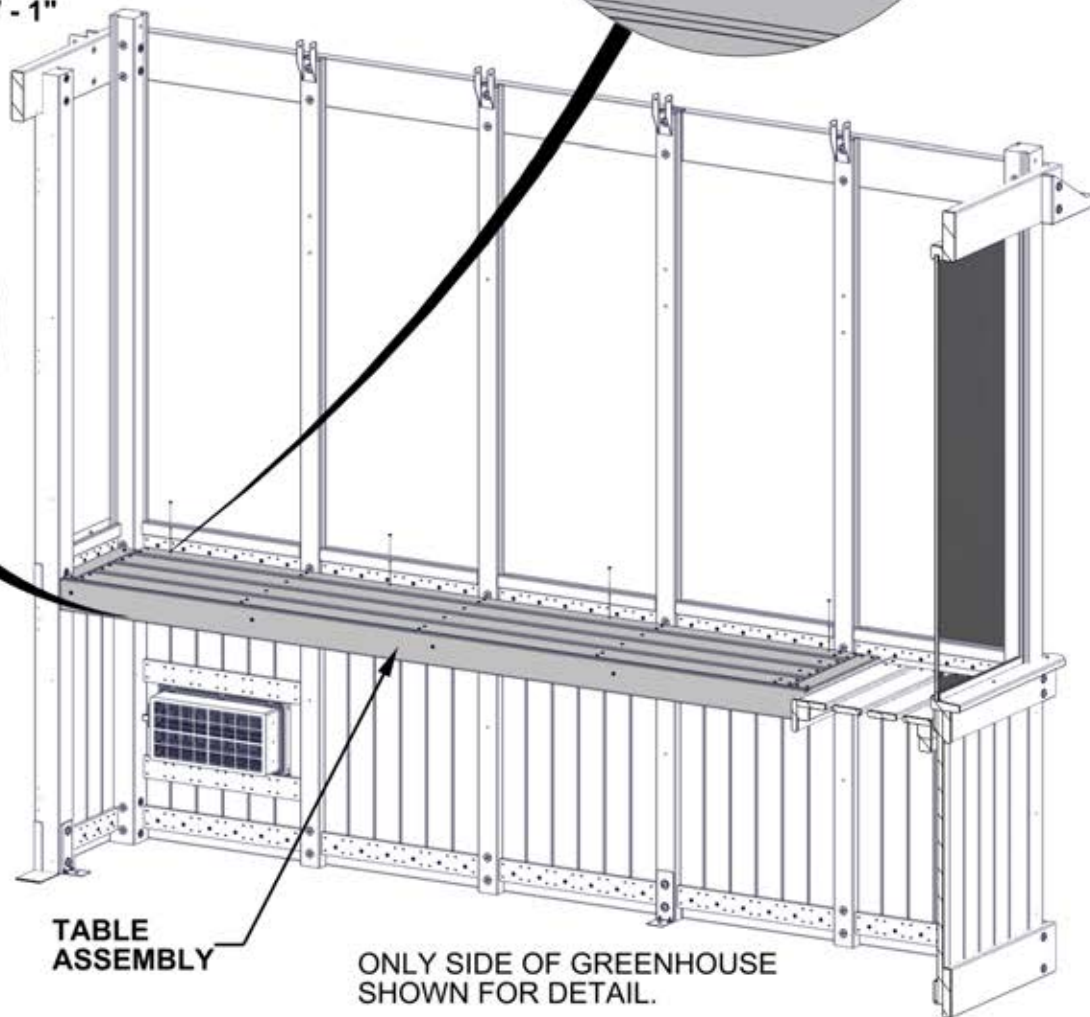

TABLE  
ASSEMBLY

ONLY SIDE OF GREENHOUSE  
SHOWN FOR DETAIL.

HAVE A SECOND PERSON HOLD TABLE IN PLACE UNTIL ANGLE BRACES ARE INSTALLED IN NEXT STEP.

# STEP 52 - TABLE ASSEMBLY

QTY	PART NUMBER	DESCRIPTION
10	H100405	WASHER LOCK EXT 6x15
10	H100456	LAG SCREW WH 1/4x2 1/2 BLK



**F02 ANGLE BRACE - W4L20039**  
(x4) 1 7/16"x2 3/8"x18 1/16" (36x60x458)



**F03 ANGLE BRACE - W4L20040**  
(x1) 1 7/16"x2 3/8"x18 1/16" (36x60x458)

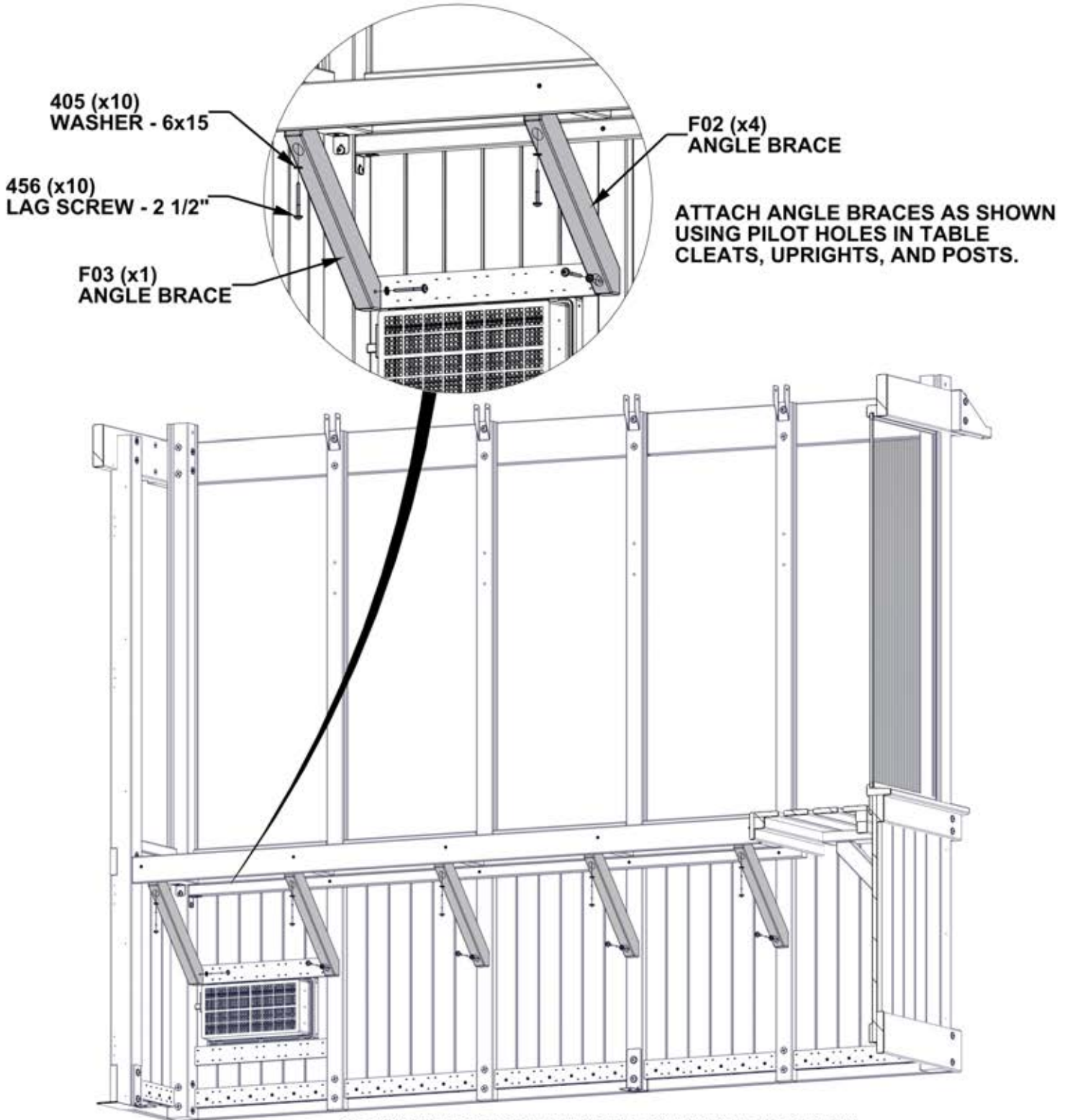

ONLY SIDE OF GREENHOUSE SHOWN FOR DETAIL.

# STEP 53 - SHELF ASSEMBLY

QTY	PART NUMBER	DESCRIPTION
8	H100397	BOLT WH 1/4x1 1/4 BLK
8	H100399	NUT BARREL WH 1/4X7/8 BLK
8	H100400	WASHER LOCK EXT 8x15



A4M02811 SHELF BRACKET  
(x4)

ATTACH SHELF BRACKETS TO UPRIGHTS AS SHOWN.

USE 90 DEGREE DRILL ADAPTER OR WRENCH FOR TOP BOLT.

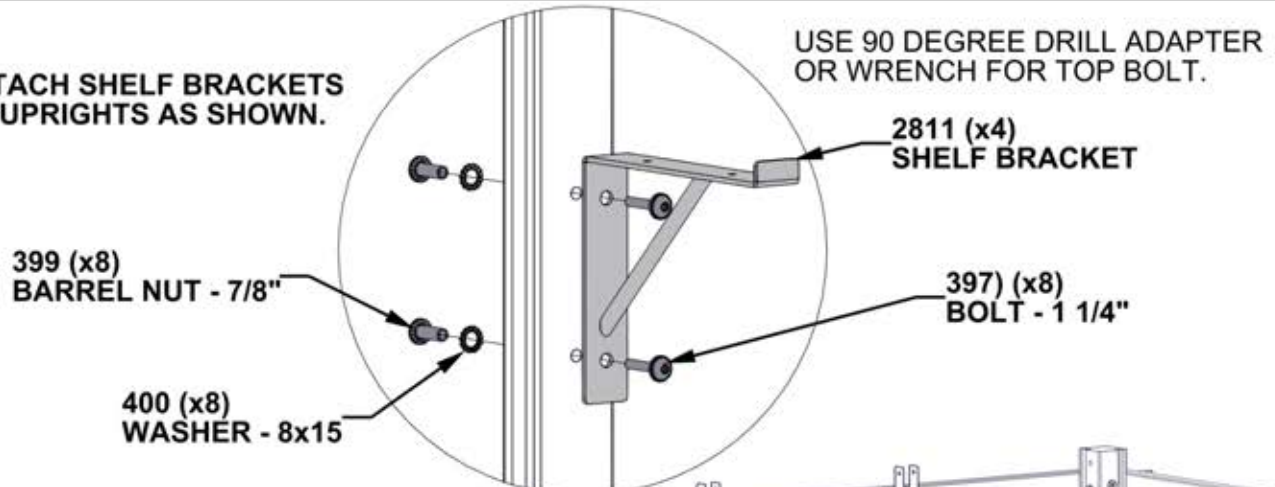

399 (x8)  
BARREL NUT - 7/8"

400 (x8)  
WASHER - 8x15

2811 (x4)  
SHELF BRACKET

397 (x8)  
BOLT - 1 1/4"

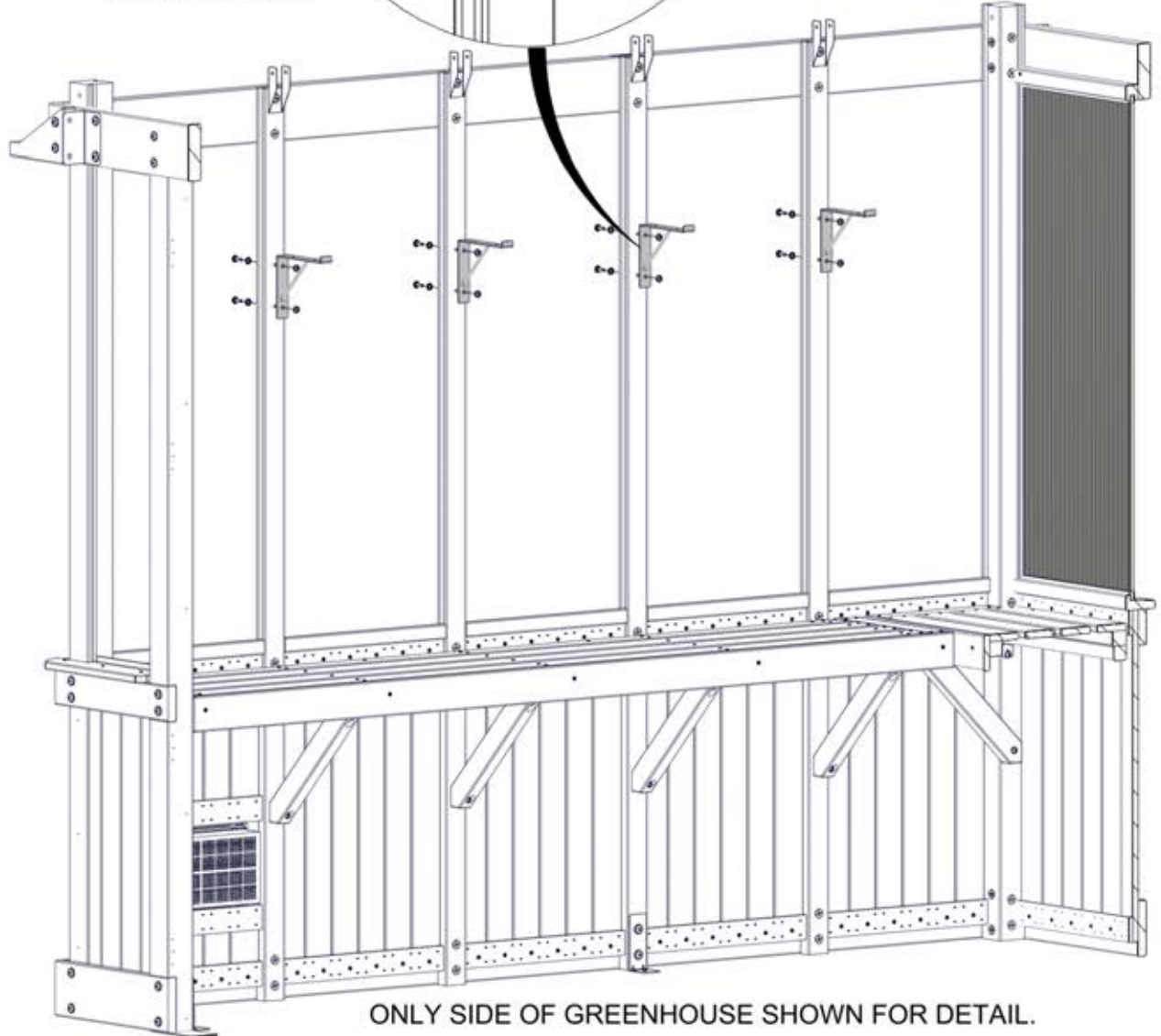

ONLY SIDE OF GREENHOUSE SHOWN FOR DETAIL.

# STEP 54 - COVER BOARD ASSEMBLY

QTY	PART NUMBER	DESCRIPTION
18	H100200	SCREW PFH 8x1 1/2 BLK



M02 COVER BOARD - W4L20041  
(x6) 5/8"x3 3/8"x24 3/16" (16x86x614)

- ALIGN PILOT HOLES IN COVER BOARDS WITH PILOT HOLES IN POSTS AND UPRIGHTS.
- ATTACH AS SHOWN.

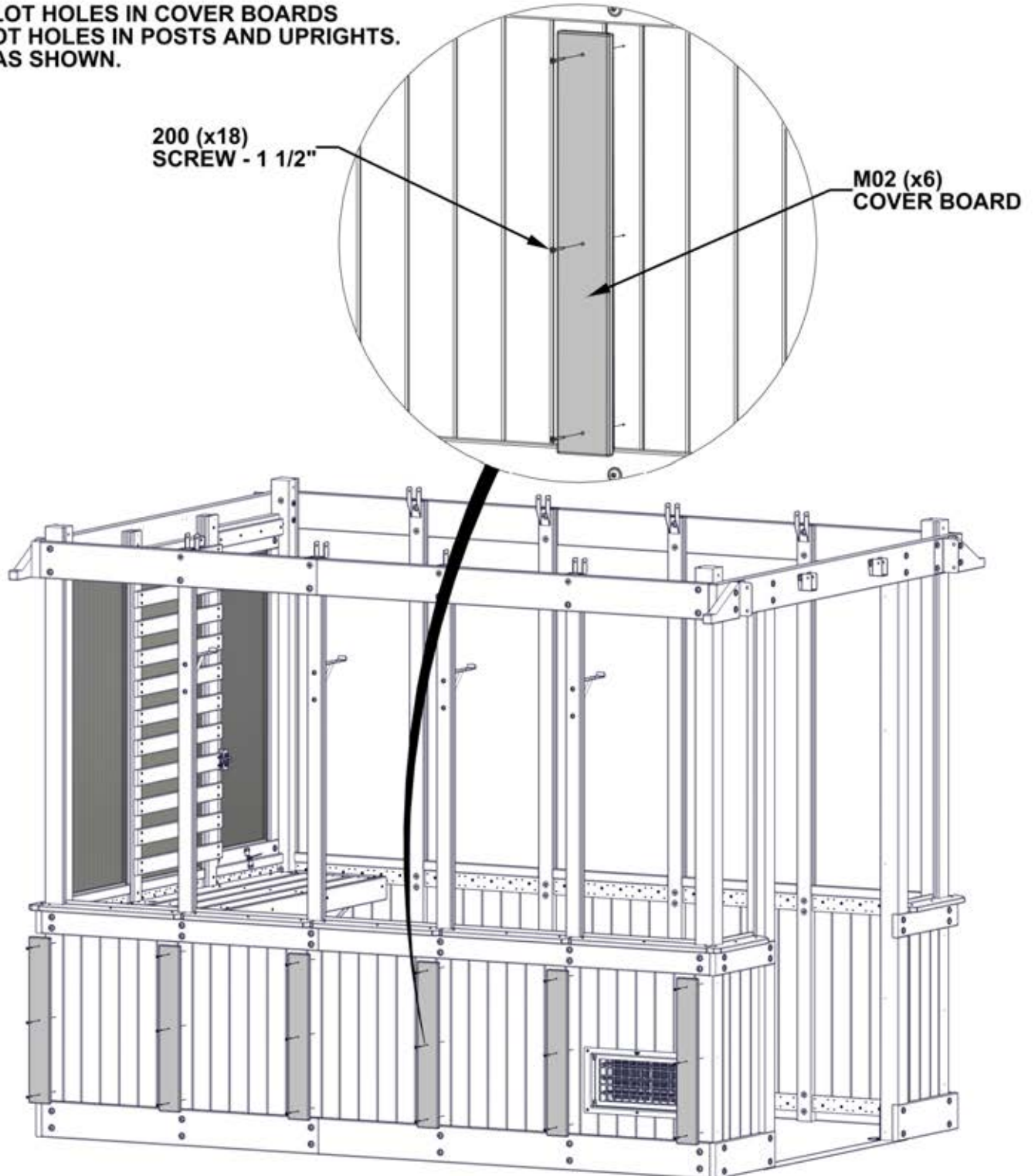

# STEP 55 - COVER BOARD ASSEMBLY

QTY	PART NUMBER	DESCRIPTION
12	H100200	SCREW PFH 8x1 1/2 BLK



M02 COVER BOARD - W4L20041  
(x2) 5/8"x3 3/8"x24 3/16" (16x86x614)

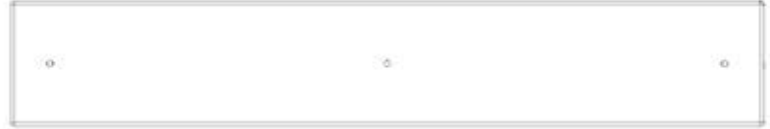

Y01 COVER BOARD - W4L20042  
(x2) 5/8"x4"x24 3/16" (16x102x614)

- ALIGN PILOT HOLES IN COVER BOARDS WITH PILOT HOLES IN POSTS AND UPRIGHTS.
- ATTACH AS SHOWN.

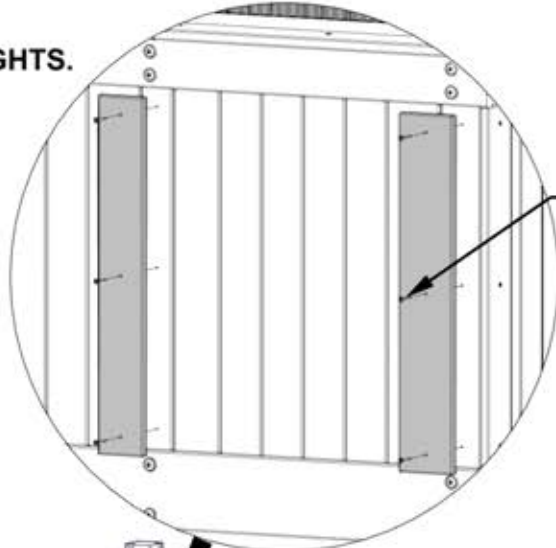

200 (x12)  
SCREW - 1 1/2"

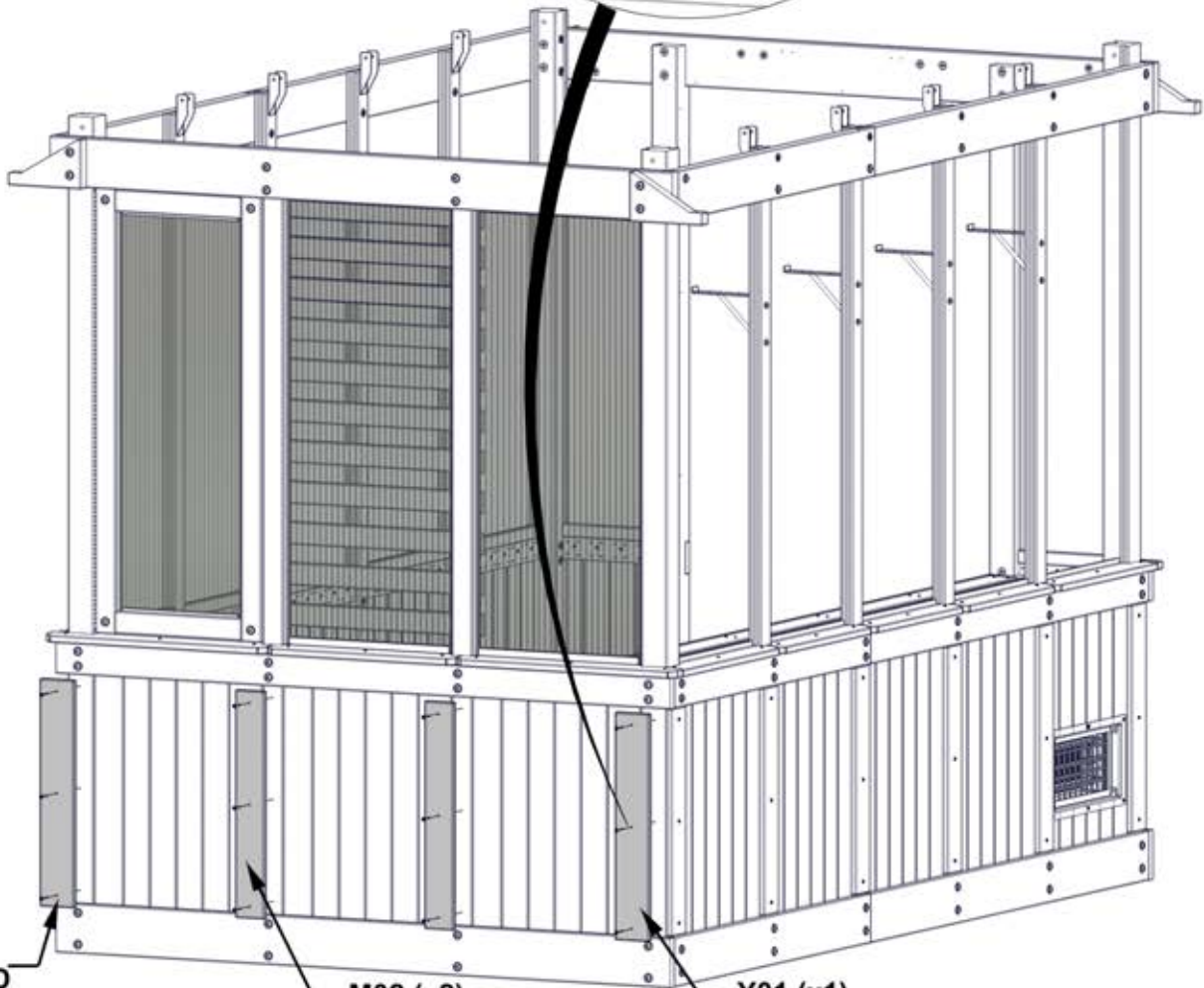

Y01 (x1)  
COVER BOARD

M02 (x2)  
COVER BOARD

Y01 (x1)  
COVER BOARD

# STEP 56 - COVER BOARD ASSEMBLY

QTY	PART NUMBER	DESCRIPTION
18	H100200	SCREW PFH 8x1 1/2 BLK



M02 COVER BOARD - W4L20041  
(x6) 5/8"x3 3/8"x24 3/16" (16x86x614)

- ALIGN PILOT HOLES IN COVER BOARDS WITH PILOT HOLES IN POSTS AND UPRIGHTS.
- ATTACH AS SHOWN.

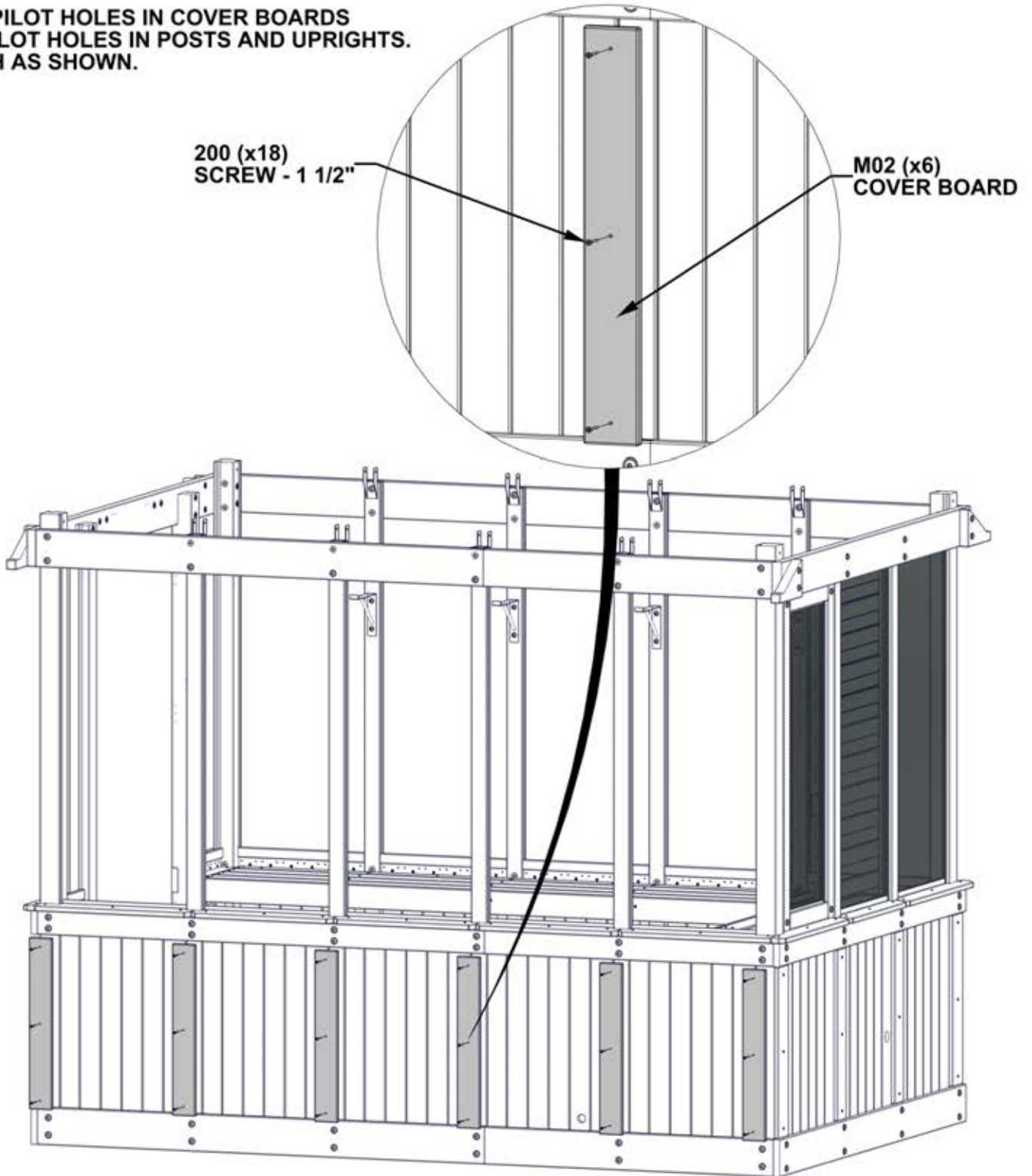

# STEP 57 - COVER BOARD ASSEMBLY

QTY	PART NUMBER	DESCRIPTION
6	H100200	SCREW PFH 8x1 1/2 BLK



Y01 COVER BOARD - W4L20042  
(x2) 5/8"x4"x24 3/16" (16x102x614)

- ALIGN PILOT HOLES IN COVER BOARDS WITH PILOT HOLES IN POSTS AND UPRIGHTS.
- ATTACH AS SHOWN.

200 (x6)  
SCREW - 1 1/2"

Y01 (x2)  
COVER BOARD

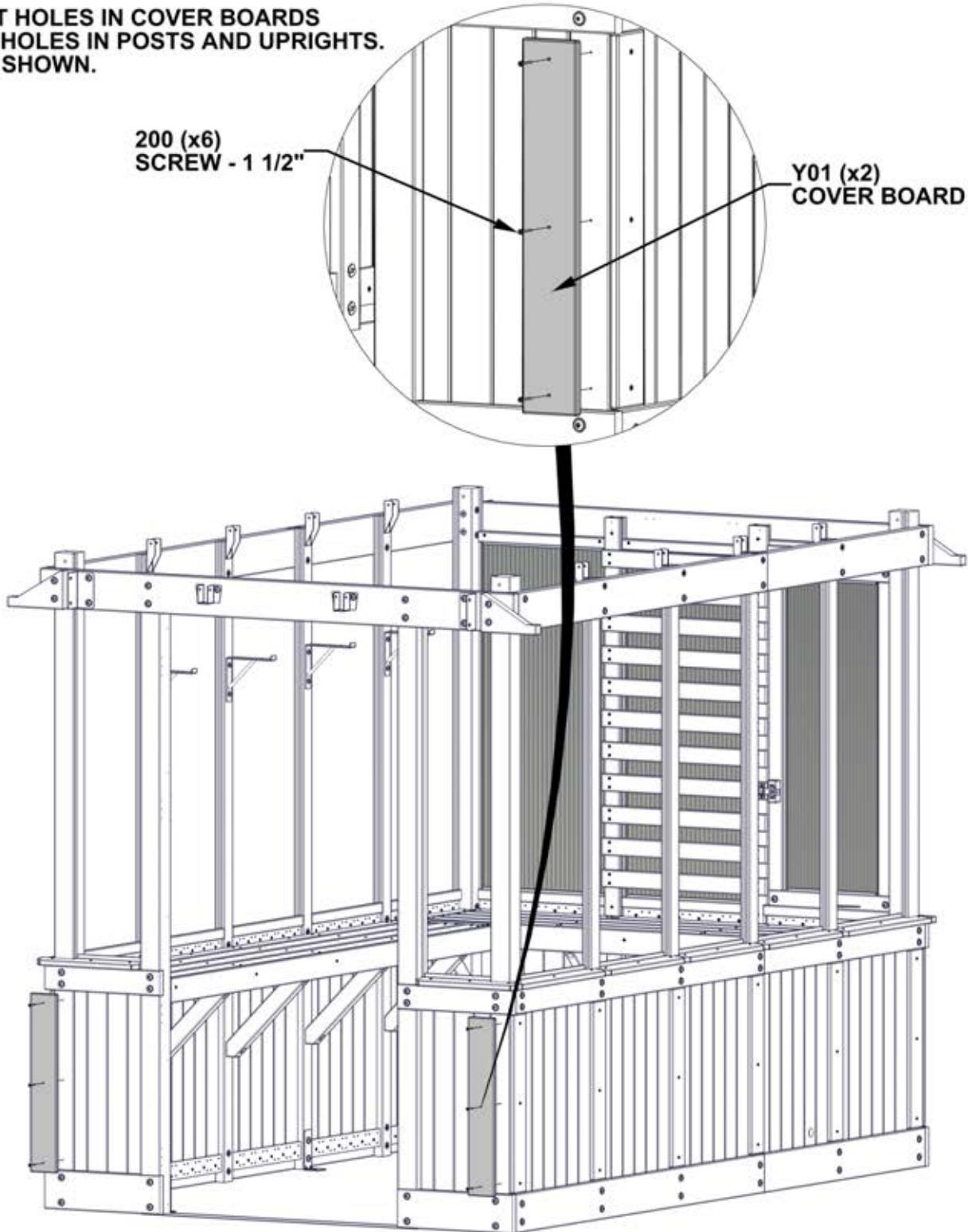

# STEP 58 - WINDOW ASSEMBLY

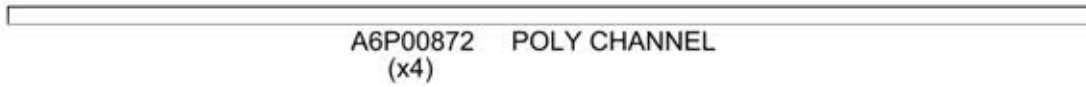

**REMOVE TAPE LINER ON POLY CHANNELS BEFORE INSTALLING.**

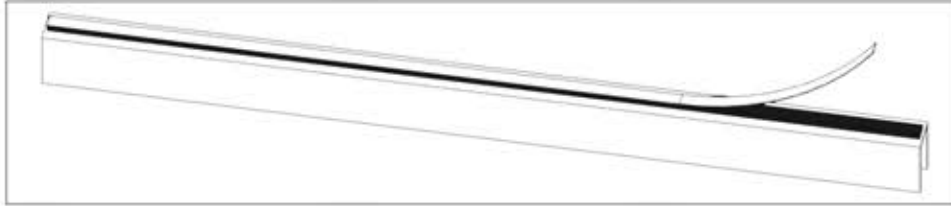

0872 (x4)  
POLY CHANNEL

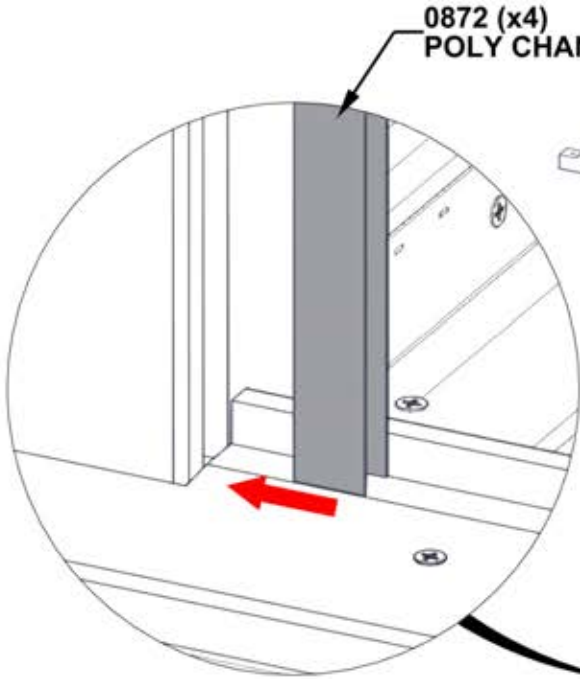

- INSERT POLY CHANNEL INTO GROOVE STARTING AT THE WINDOW SILL AND WORK UPWARDS.
- FIRMLY PRESS CHANNEL INTO GROOVE TO ENSURE TAPE ADHESION.

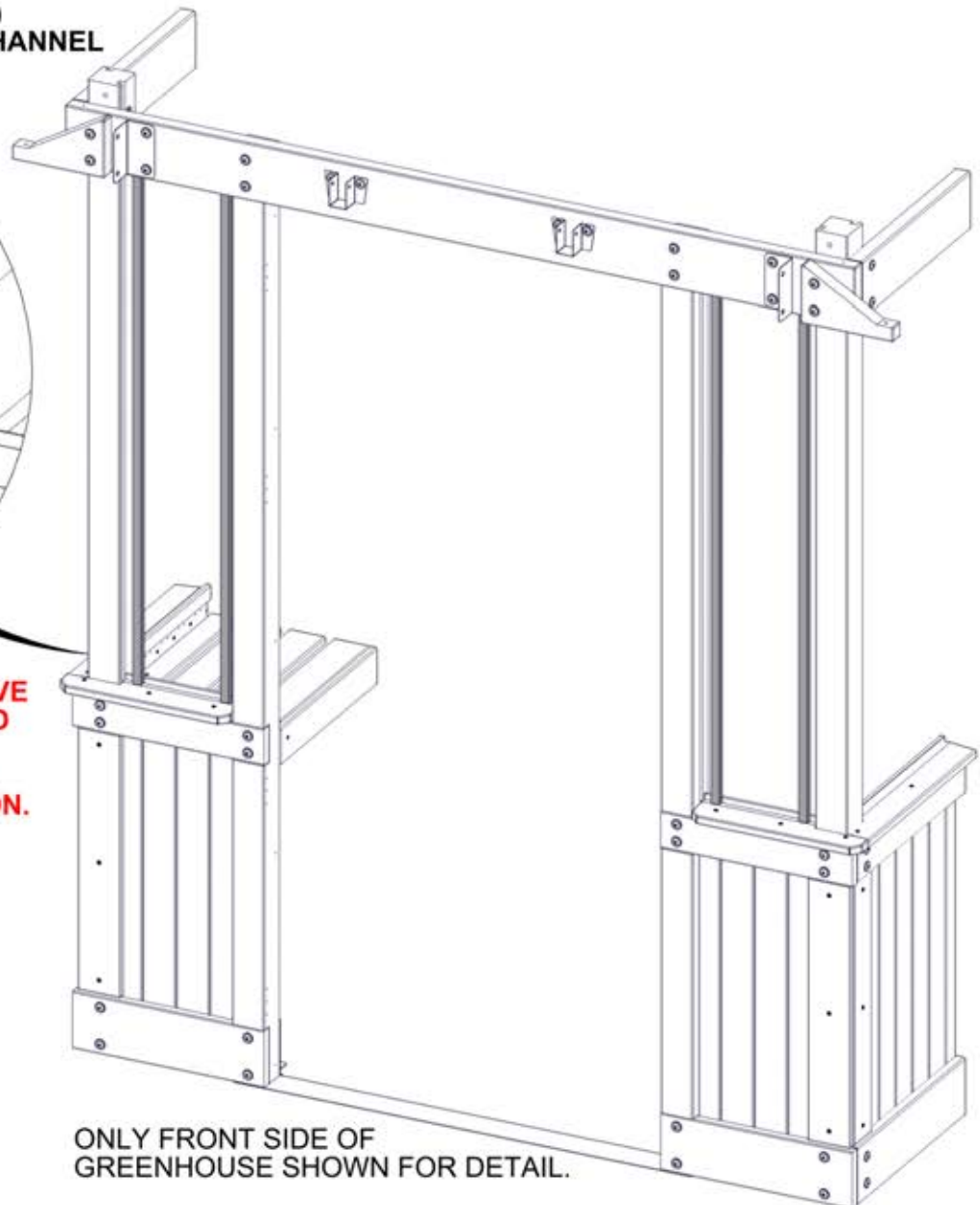

ONLY FRONT SIDE OF GREENHOUSE SHOWN FOR DETAIL.

# STEP 59 - WINDOW ASSEMBLY

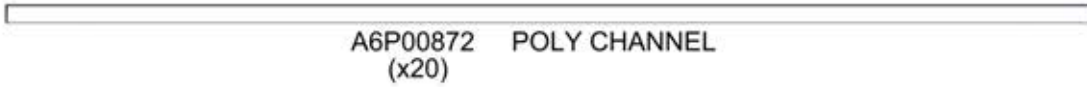

**REMOVE TAPE LINER ON POLY CHANNELS BEFORE INSTALLING.**

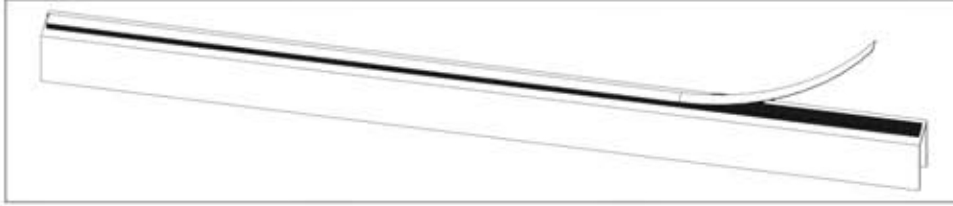

**0872 (x20)  
POLY CHANNEL**

- INSERT POLY CHANNEL INTO GROOVE STARTING AT THE WINDOW SILL AND WORK UPWARDS.
- FIRMLY PRESS CHANNEL INTO GROOVE TO ENSURE TAPE ADHESION.

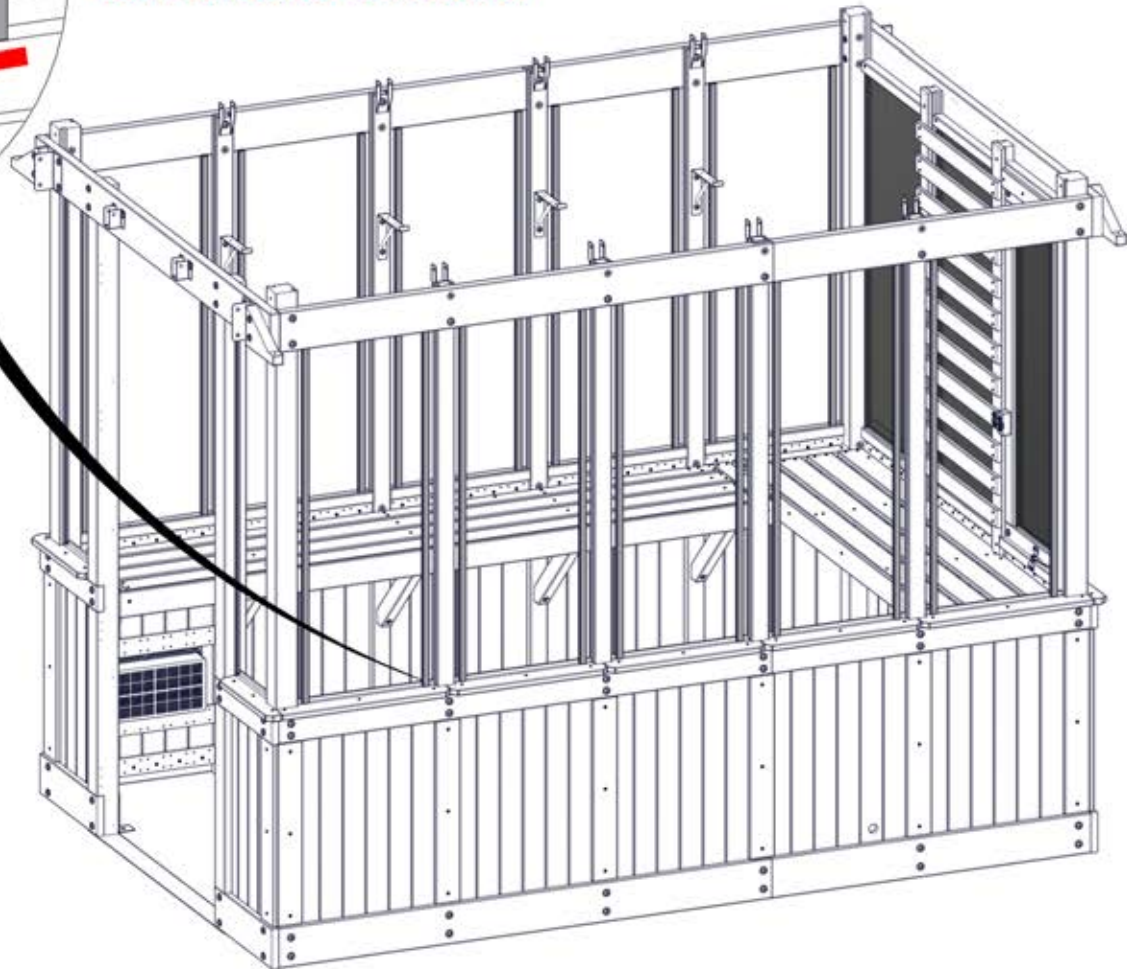
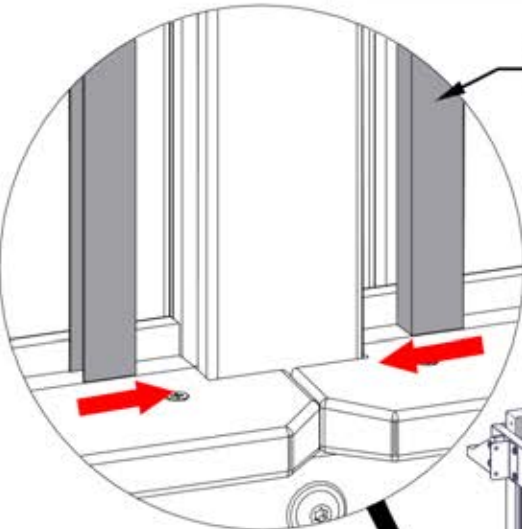

# STEP 60 - WINDOW ASSEMBLY



A6P00870 POLY SHEET  
(x10)



A6P00871 POLY CHANNEL  
(x20)



A6P00690 DUST SEAL TAPE

## TO APPLY DUST SEAL TAPE AND POLY CHANNEL:

- CUT 2 STRIPS OF DUST SEAL TAPE THE SAME WIDTH AS THE POLY SHEET.
- WRAP DUST SEAL TAPE ALONG EDGE OF POLY SHEET WIDTH.
- AFTER TAPE IS SECURE, PUSH CHANNEL ON OVER THE TAPE, CENTERING ON THE POLY SHEET.
- REPEAT ON THE BOTTOM SIDE OF POLY SHEET.
- **REPEAT FOR ALL 10 WINDOW ASSEMBLIES.**

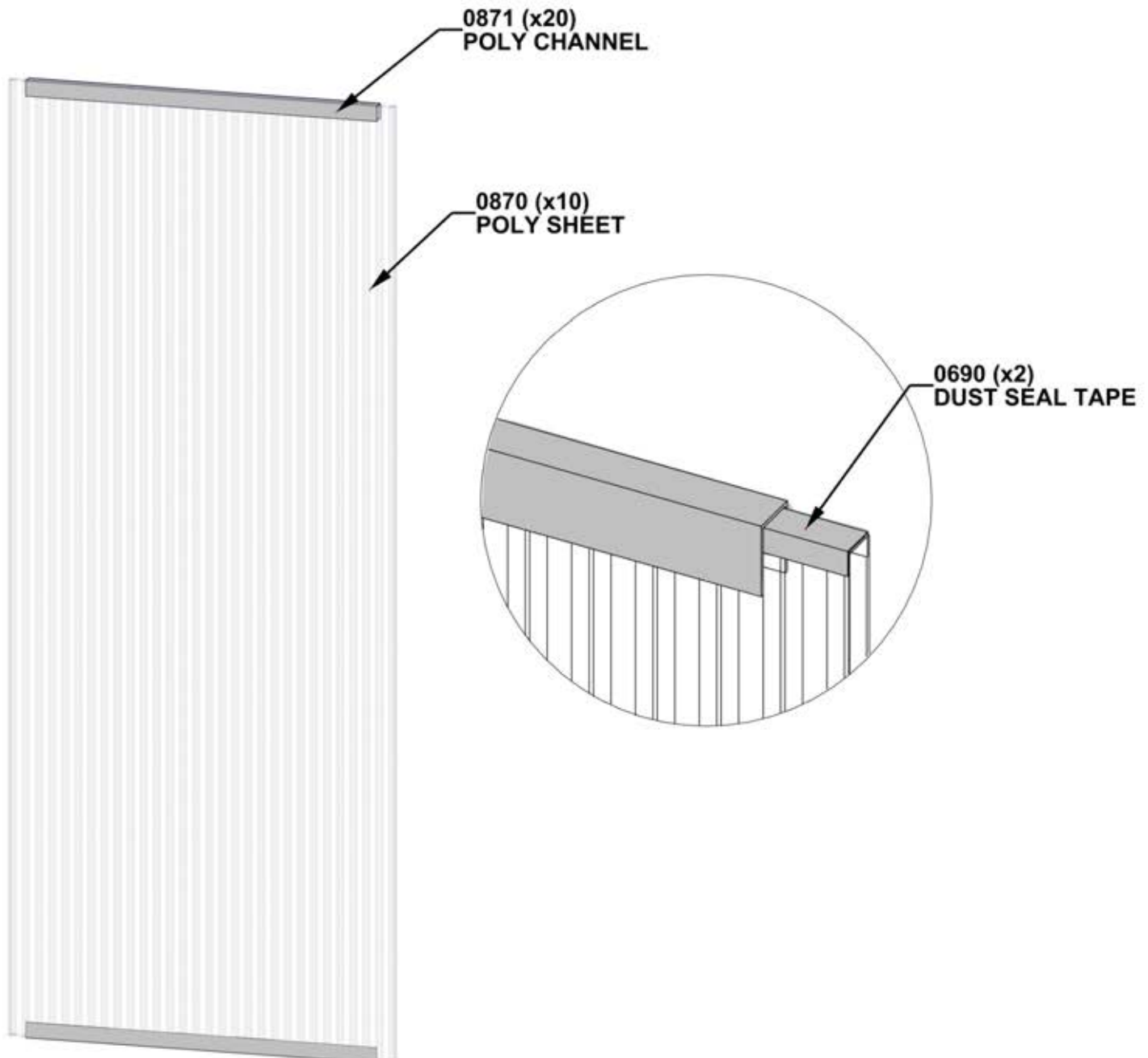

# STEP 61 - WINDOW ASSEMBLY

## IMPORTANT!

- ENSURE UV SIDE OF WINDOW IS FACING OUTSIDE.
- ONCE WINDOW IS INSTALLED, IT IS SAFE TO REMOVE THE PROTECTIVE FILM.

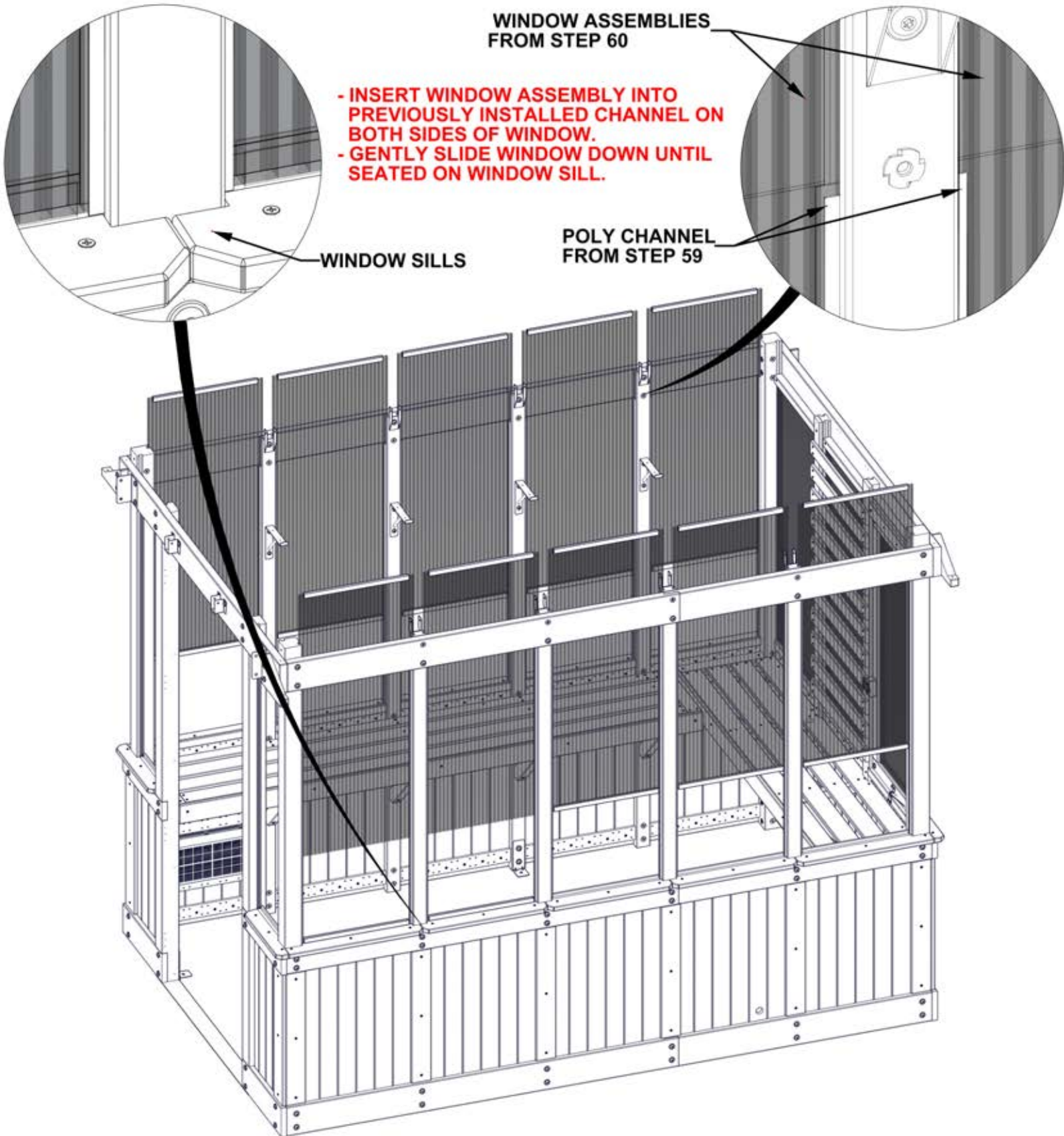

# STEP 62 - WINDOW ASSEMBLY



A6P00914 POLY SHEET  
(x2)



A6P00915 POLY CHANNEL  
(x4)



A6P00690 DUST SEAL TAPE

## TO APPLY DUST SEAL TAPE AND POLY CHANNEL:

- CUT 2 STRIPS OF DUST SEAL TAPE THE SAME WIDTH AS THE POLY SHEET.
- WRAP DUST SEAL TAPE ALONG EDGE OF POLY SHEET WIDTH.
- AFTER TAPE IS SECURE, PUSH CHANNEL ON OVER THE TAPE, CENTERING ON THE POLY SHEET.
- REPEAT ON THE BOTTOM SIDE OF POLY SHEET.
- **REPEAT FOR BOTH WINDOW ASSEMBLIES.**

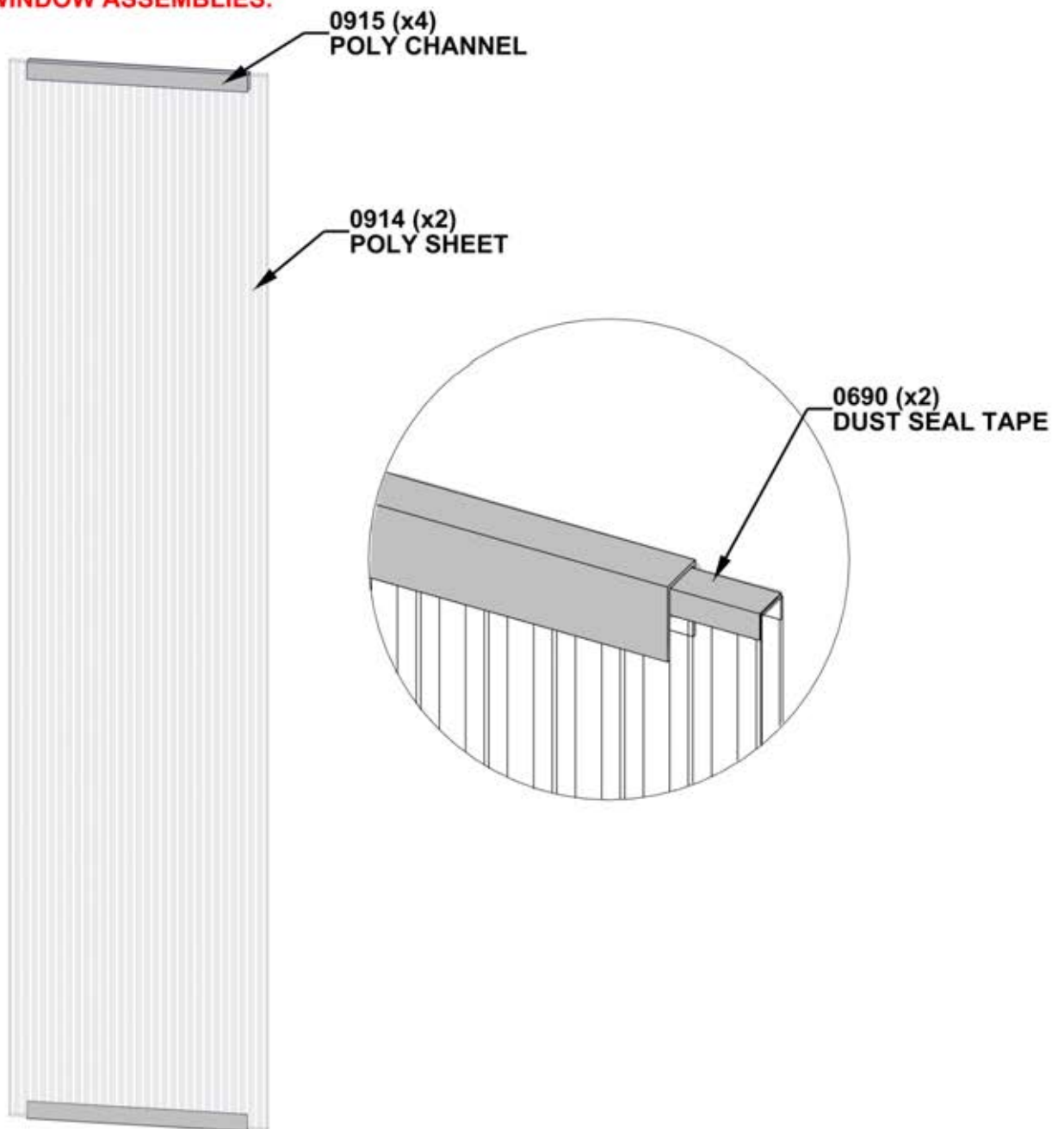

# STEP 63 - WINDOW ASSEMBLY

## IMPORTANT!

- ENSURE UV SIDE OF WINDOWS ARE FACING OUTSIDE.
- ONCE WINDOWS ARE INSTALLED, IT IS SAFE TO REMOVE THE PROTECTIVE FILM.

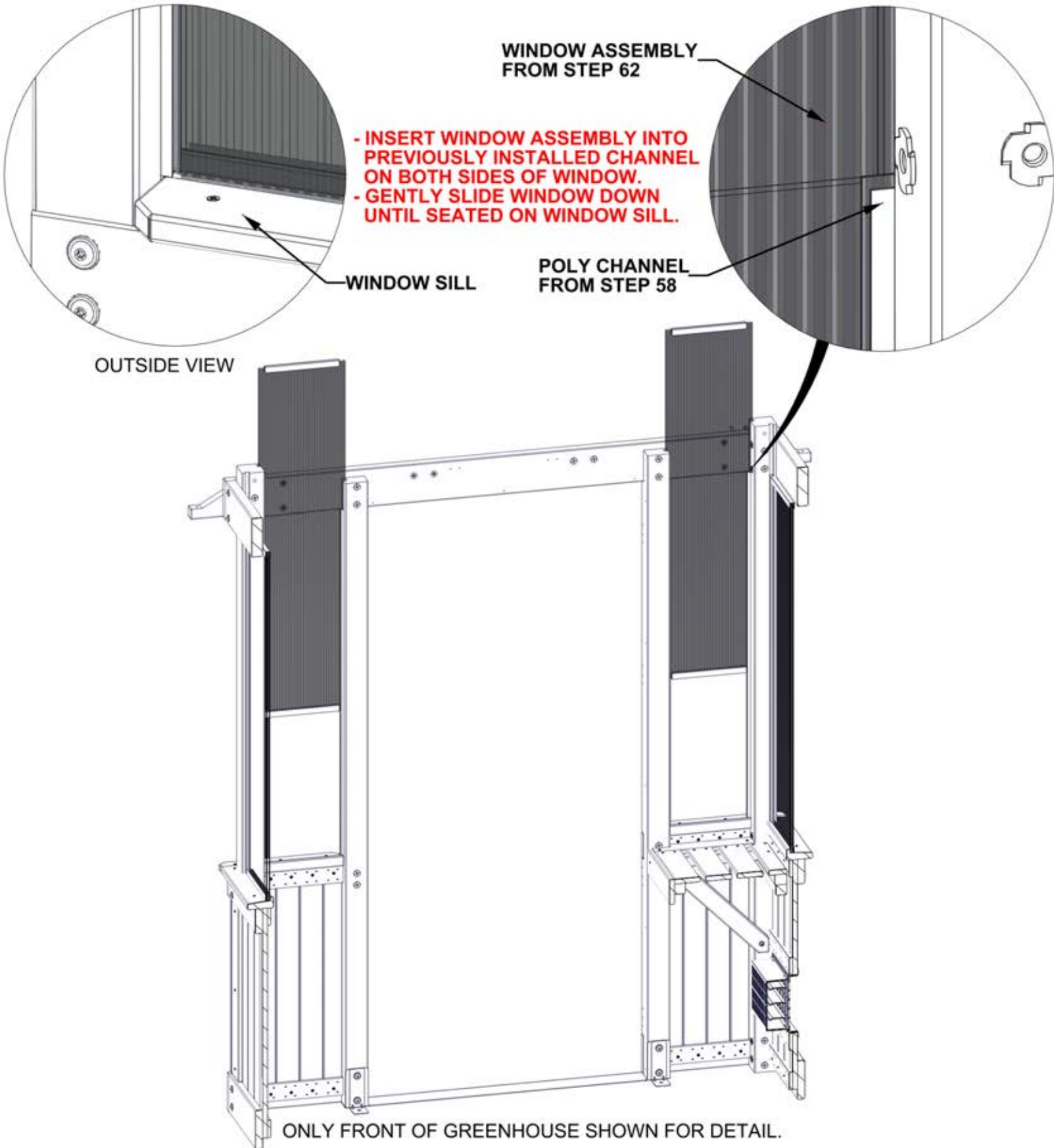

# STEP 64 - WINDOW ASSEMBLY

QTY	PART NUMBER	DESCRIPTION
20	H100391	SCREW PFH 8x2 BLK



P02 WINDOW CAP - W4L20038  
(x10) 1 7/16"x1 7/16"x18 7/8" (36x36x480)

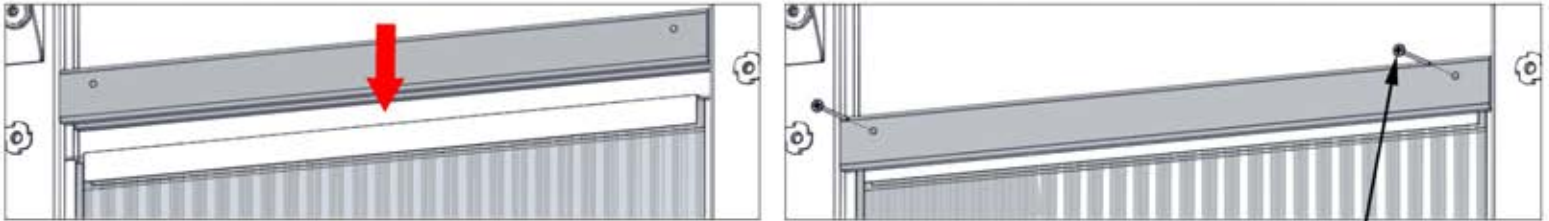

SLIDE GROOVE IN WINDOW CAP OVER WINDOW ASSEMBLY AND SCREW INTO PLACE.

391 (x20)  
SCREW - 2"

INSTALL WINDOW CAPS ON BOTH SIDES OF THE GREENHOUSE.

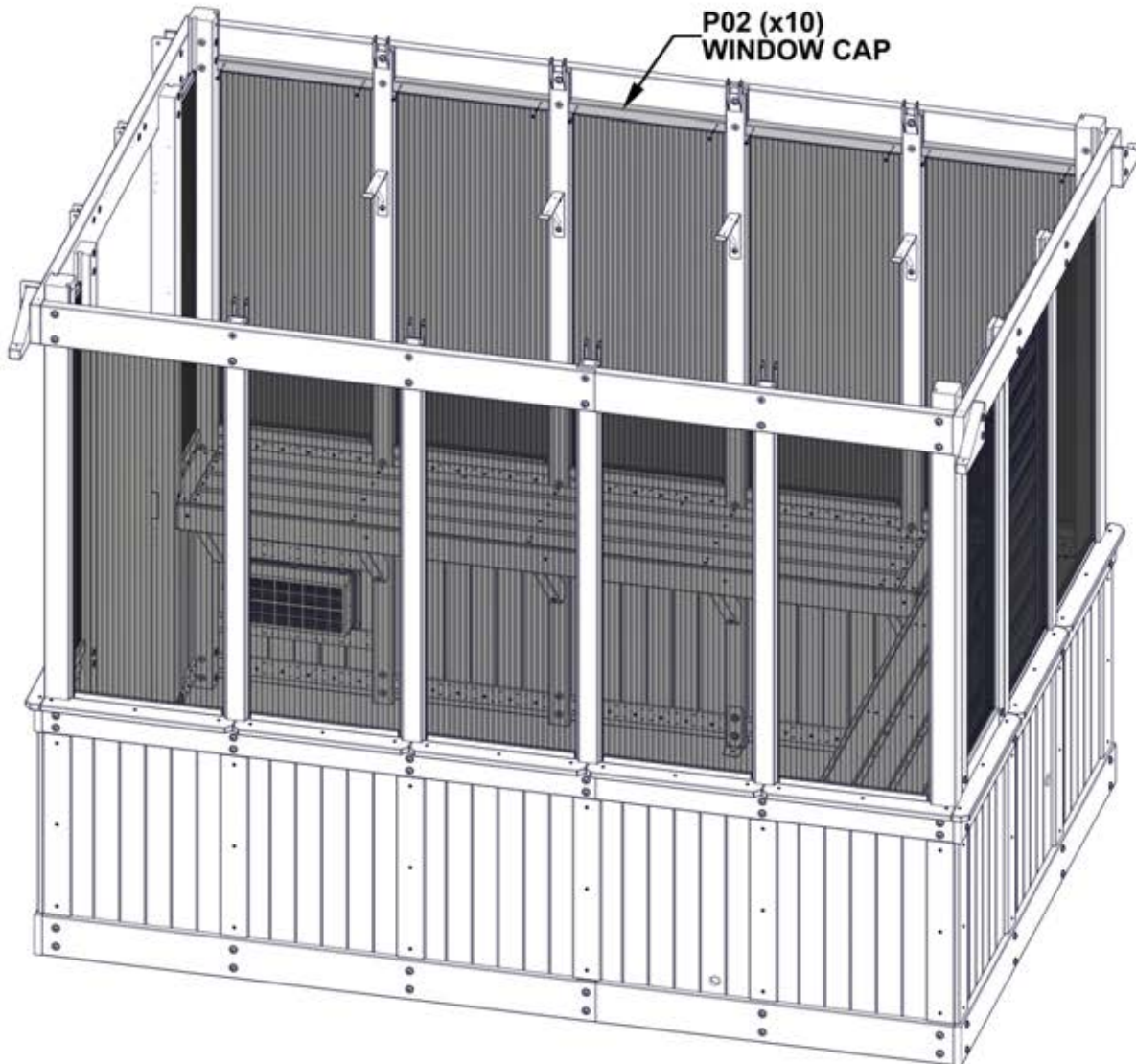

# STEP 65 - WINDOW ASSEMBLY

QTY	PART NUMBER	DESCRIPTION
4	H100391	SCREW PFH 8x2 BLK



P03 WINDOW CAP - W4L20061  
(x2) 1 7/16"x1 7/16"x10 7/8" (36x36x274)

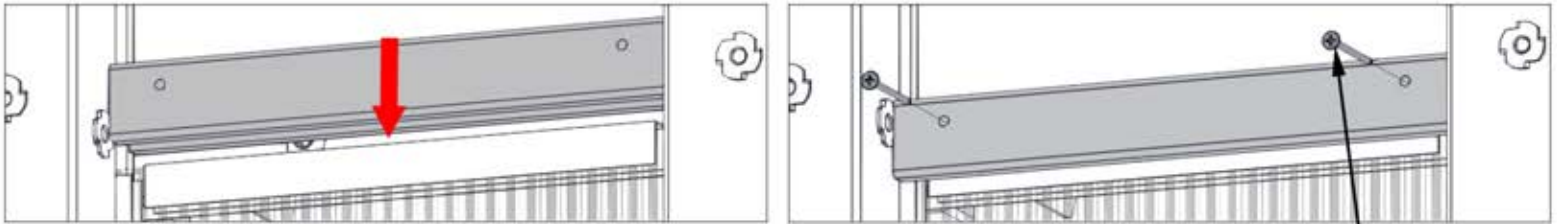

**SLIDE GROOVE IN WINDOW CAP OVER WINDOW ASSEMBLY AND SCREW INTO PLACE.**

391 (x4)  
SCREW - 2"

P03 (x2)  
WINDOW CAP

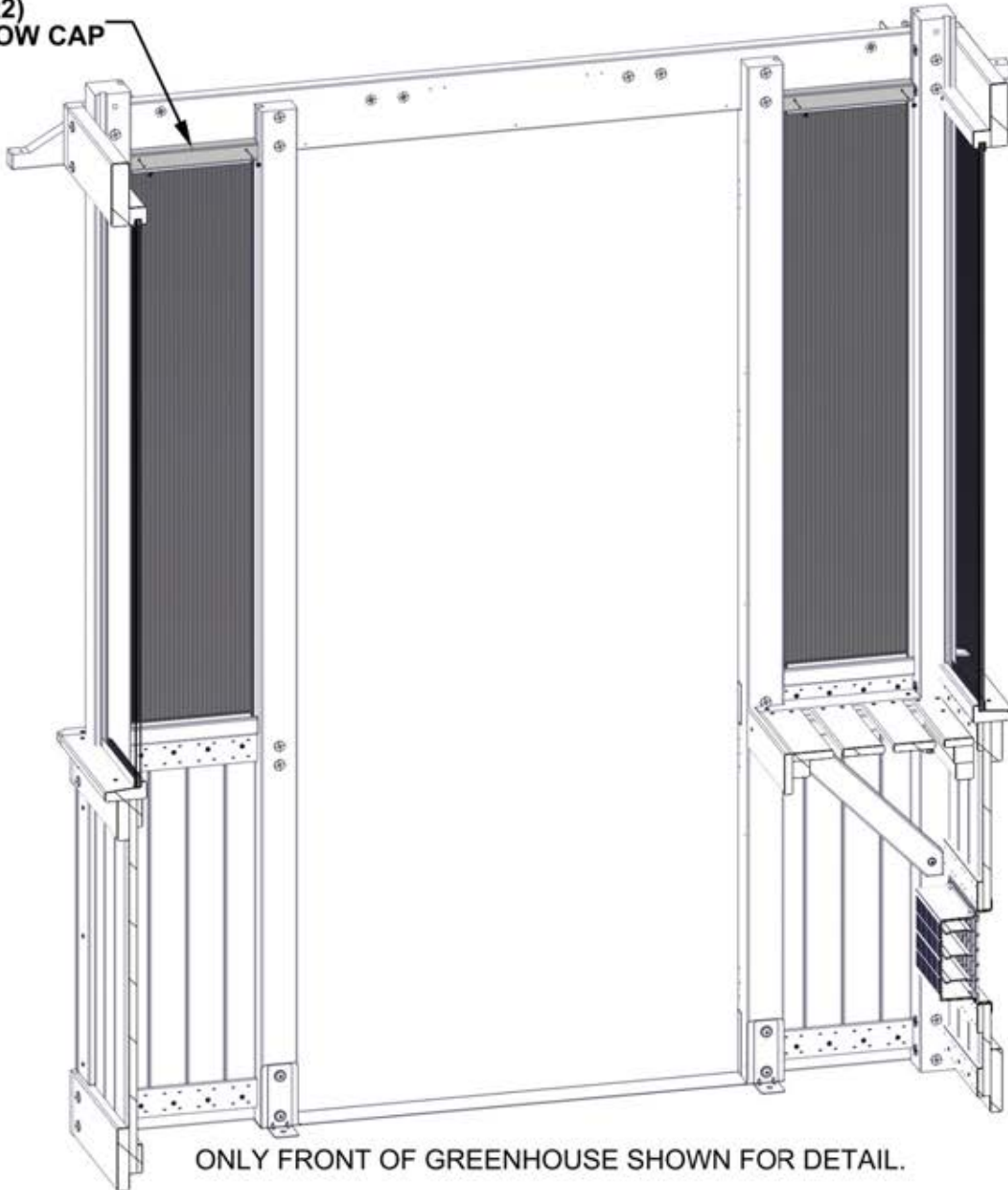

ONLY FRONT OF GREENHOUSE SHOWN FOR DETAIL.

# STEP 66 - SHELF ASSEMBLY

QTY	PART NUMBER	DESCRIPTION
8	H100392	SCREW PWH 8x3/4 BLK



H04 SHELF BOARD - W4L20067  
(x2) 15/16"x3 3/8"x68 1/4" (24x86x1734)

ALIGN PILOT HOLES IN H04 BOARDS WITH HOLES IN SHELF BRACKETS AND ATTACH.

USE PHILLIPS EXTENSION BIT FOR INSTALLING SCREWS.

392 (x8)  
SCREW - 3/4"

H04 (x2)  
SHELF BOARD

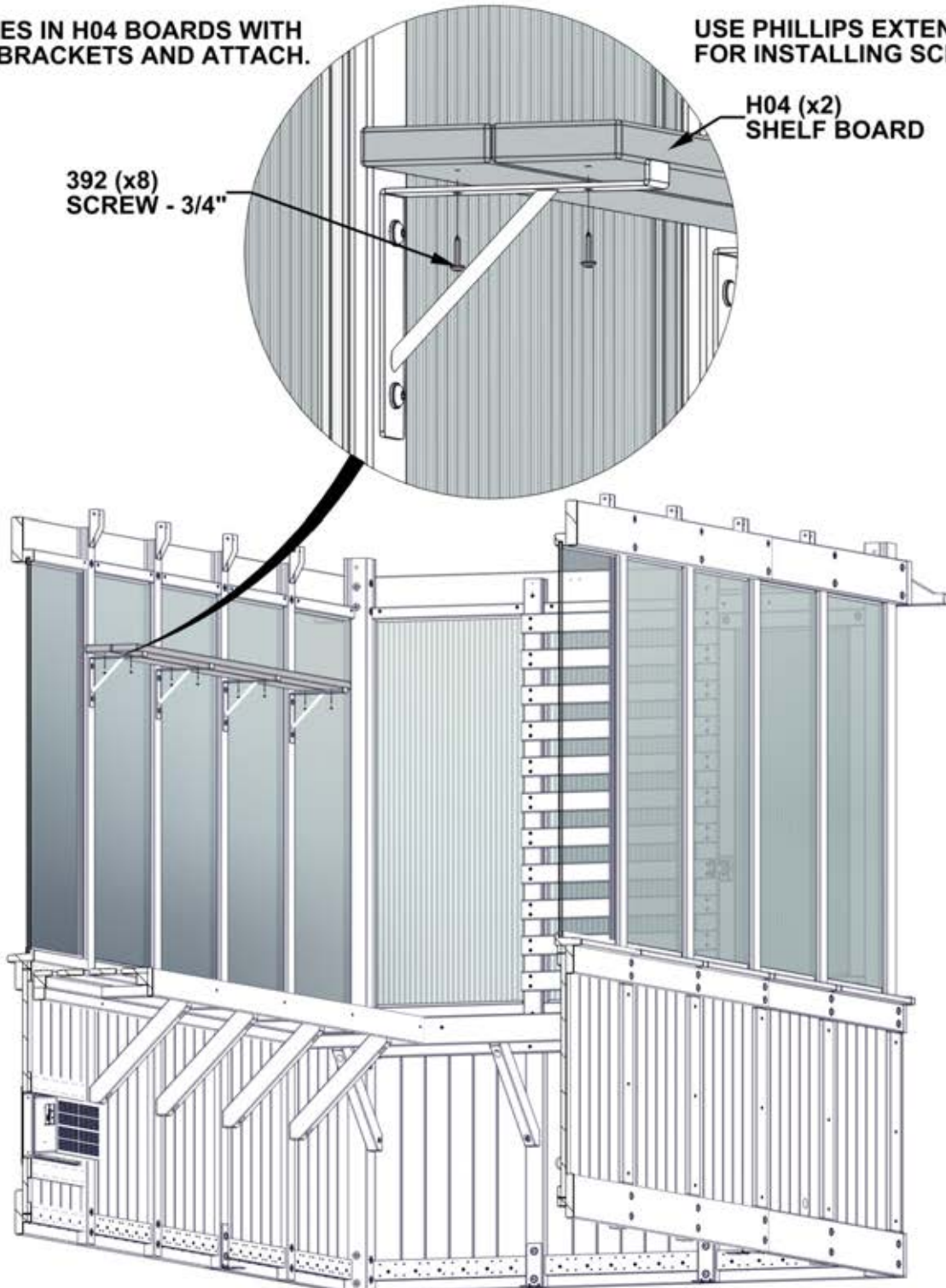

FRONT WALL OF GREENHOUSE NOT SHOWN FOR DETAIL.

# STEP 67 - DOOR TRIM ASSEMBLY

QTY	PART NUMBER	DESCRIPTION
10	H100391	SCREW PFH 8x2 BLK

O01 DOOR STOP - W4L20063  
(x2) 5/8"x1 5/16"x80 5/16" (16x34x2040)

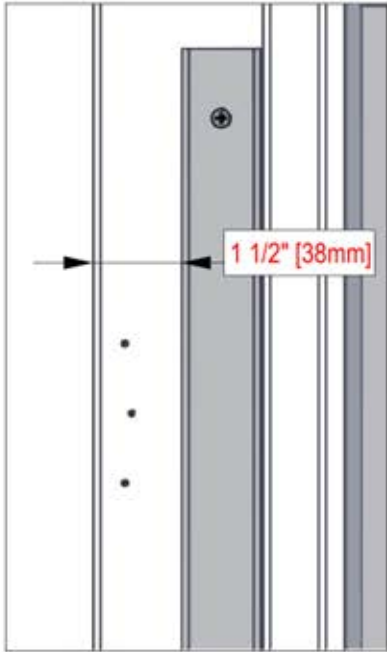

1 1/2" [38mm]

**ENSURE THAT DOOR STOP IS 1 1/2" [38mm] FROM FRONT OF POST AS SHOWN.**

**ALIGN PILOT HOLES AND ATTACH AS SHOWN.**

391 (x10)  
SCREW - 2"

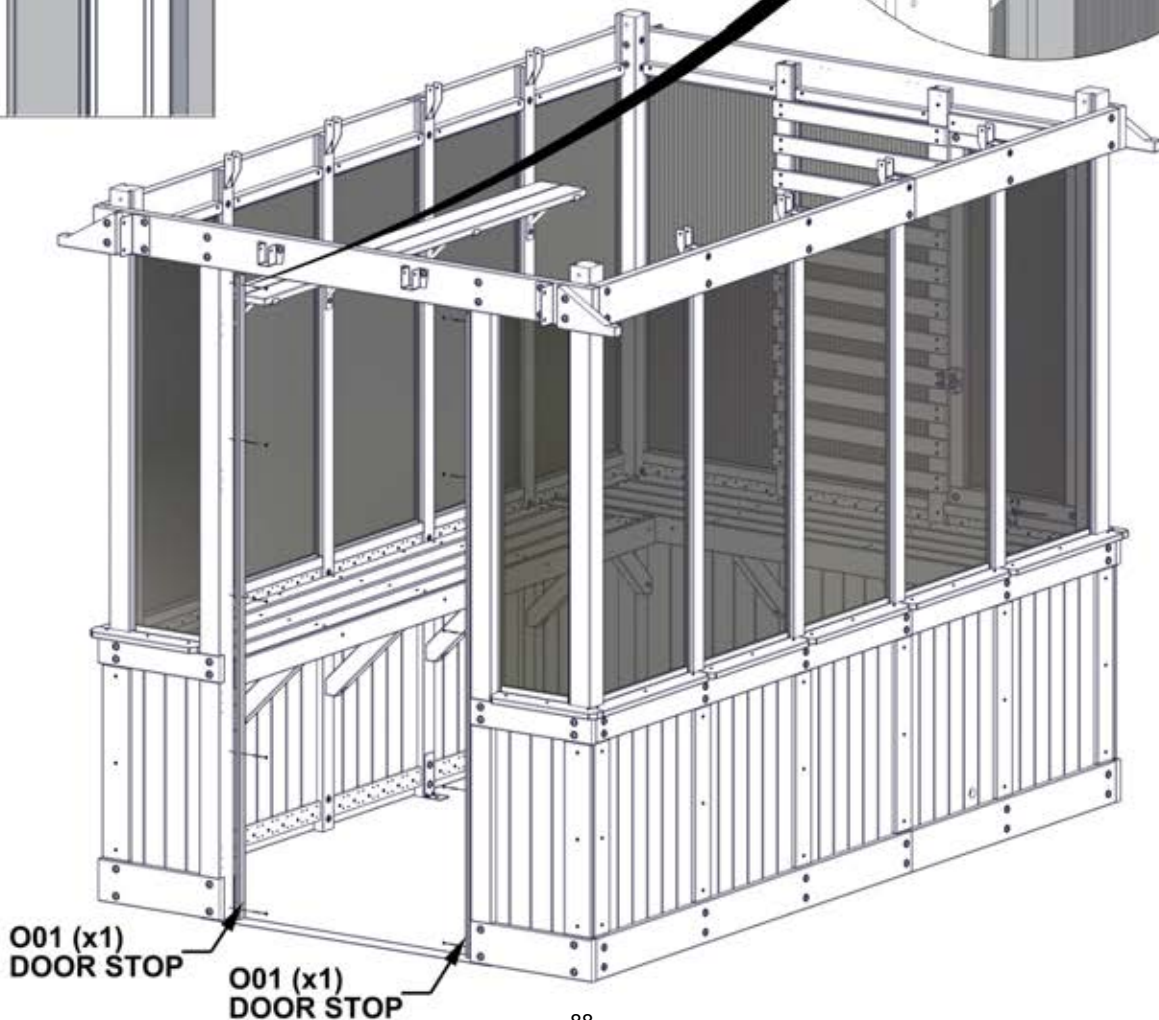
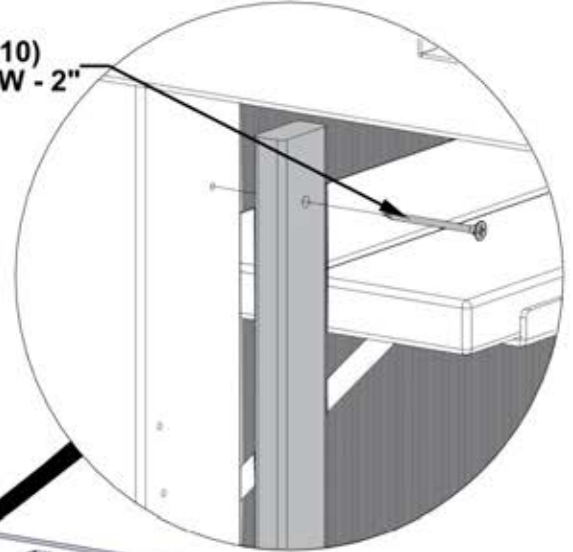

O01 (x1)  
DOOR STOP

O01 (x1)  
DOOR STOP

# STEP 68 - DOOR TRIM ASSEMBLY

QTY	PART NUMBER	DESCRIPTION
3	H100201	SCREW PFH 8x2 1/2 BLK



AA01 DOOR STOP - W4L20064  
(x1) 1 7/8"x1 15/16"x36 15/16" (47x50x938)

- NOTE NOTCH FOR CORRECT ORIENTATION.
- ALIGN PILOT HOLES AND ATTACH AS SHOWN.

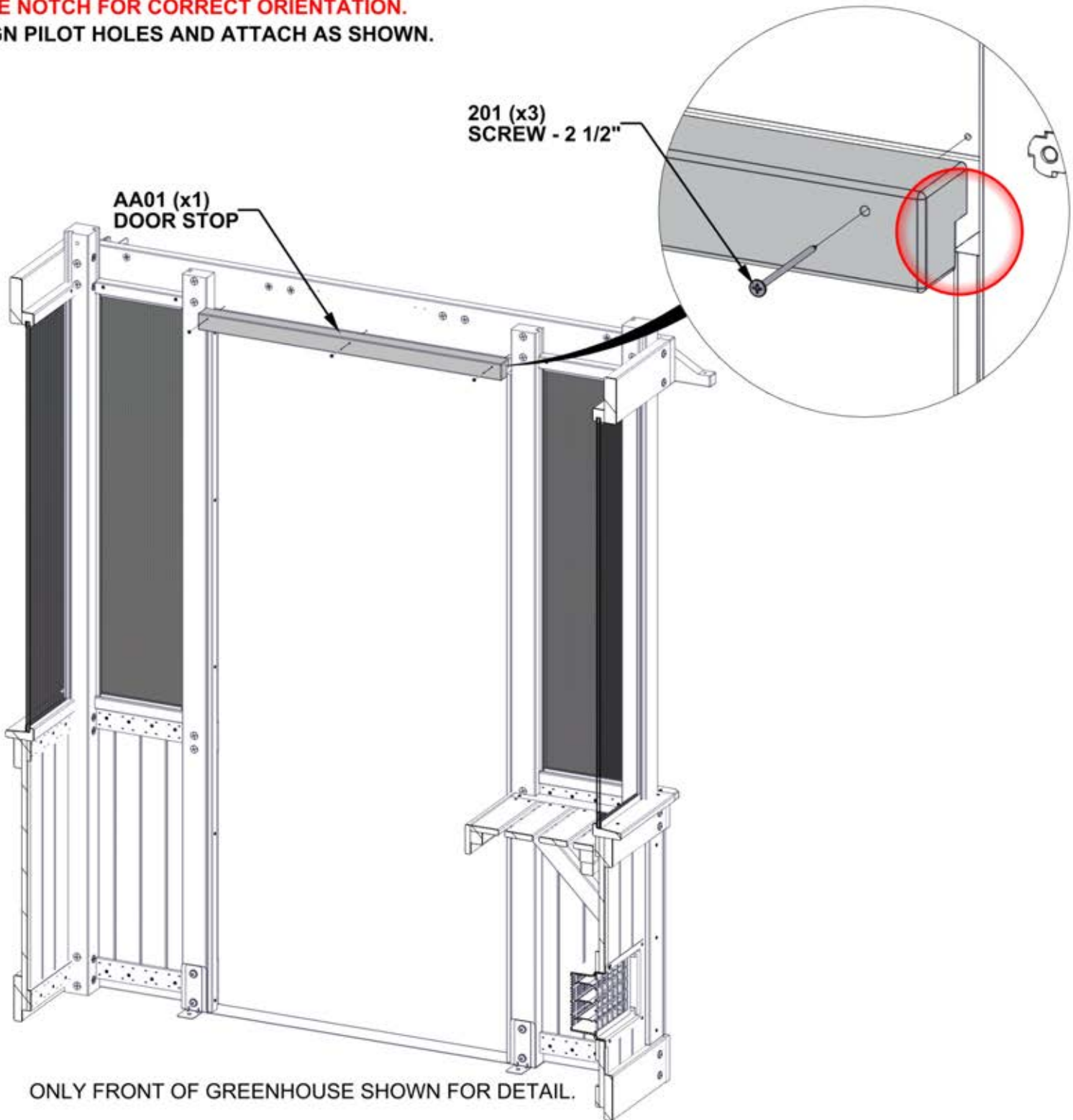

# STEP 69 - GABLE ASSEMBLY

QTY	PART NUMBER	DESCRIPTION
8	H100201	SCREW PFH 8x2 1/2 BLK



D04 GABLE - W4L20053  
(x2) 4 3/16"x5 1/4"x50 1/16" (36x134x1272)



E06 RAFTER - W4L20055  
(x2) 1 7/16"x3 3/8"x47 3/8" (36x86x1203)

FLUSH BOARDS FOR PROPER ALIGNMENT. THEY WILL BE ATTACHED IN NEXT

D04 (x2)  
GABLE

**ENSURE HOLES ALIGN WITH HOLES IN D04 BOARDS.**

E06 (x2)  
RAFTER

201 (x8)  
SCREW - 2 1/2"

3/4" [18mm]

**ENSURE MEASUREMENT IS CORRECT ON BOTH D04 BOARDS.**

# STEP 70 - GABLE ASSEMBLY

QTY	PART NUMBER	DESCRIPTION
2	H100195	BOLT WH 5/16x2 3/4 BLK
2	H100379	TNUT-5/16" BLK
2	H100471	LAG SCREW WH 5/16x1 1/2 BLK
2	H100478	WASHER FLAT 8x27 BLK
2	H100479	NUT LOCK 5/16 BLK
2	H100503	BOLT WH 5/16x3 1/2 BLK

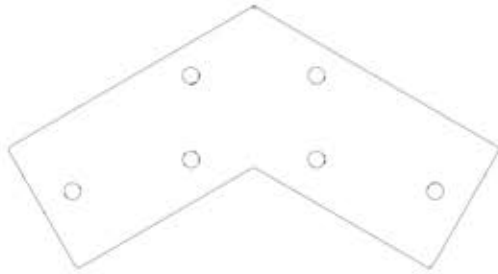

A4M02086 GABLE BRACKET (x1)

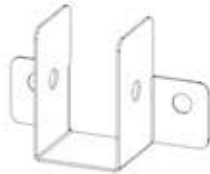

A4M02085 RIDGE CLIP (x1)

- INSERT T-NUTS FIRST.
- HAND TIGHTEN ONLY.
- ATTACH GABLES WITH GABLE BRACKET AS SHOWN.
- NOTE CORRECT ORIENTATION OF RIDGE CLIP.

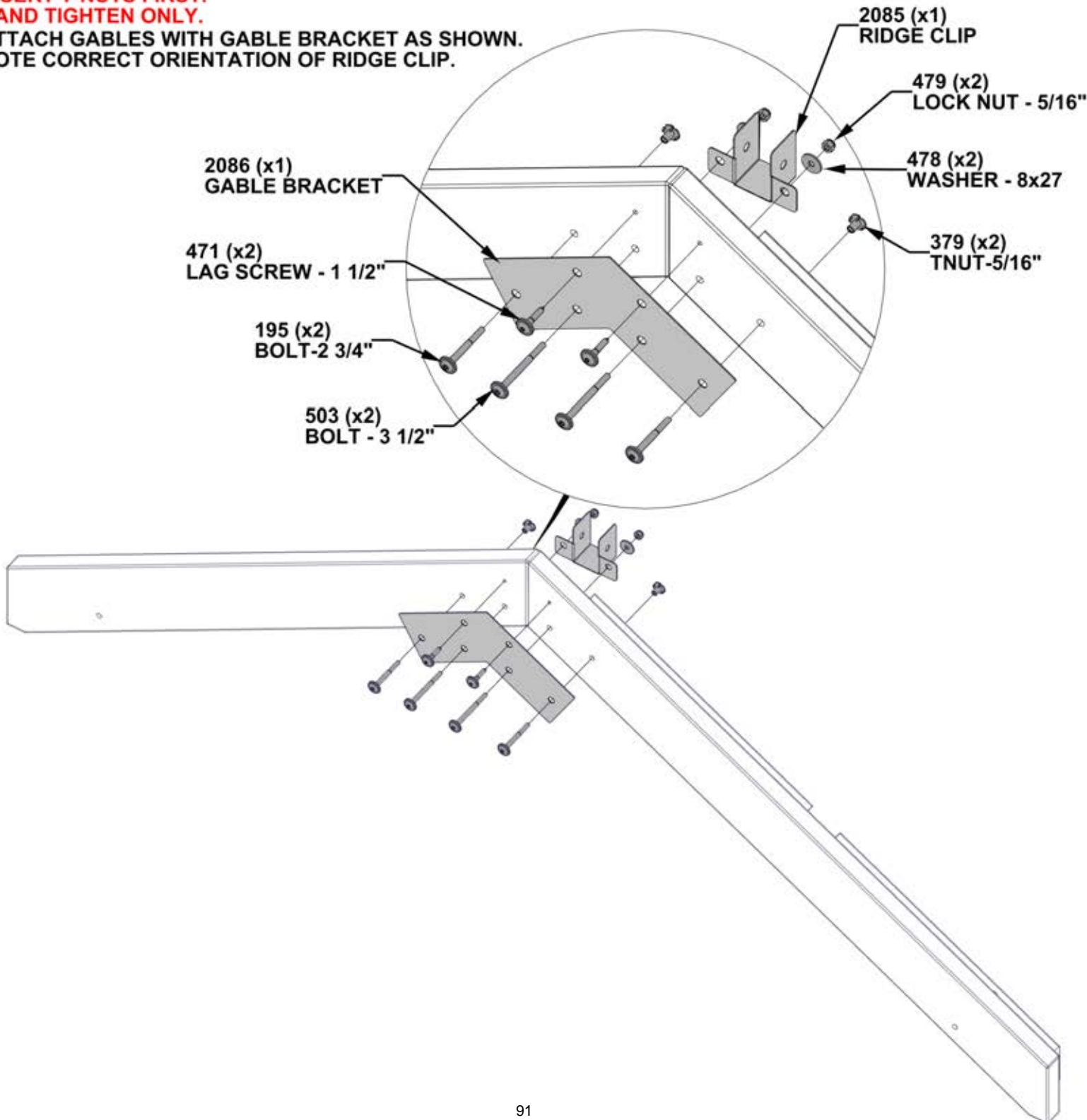

**REPEAT STEPS 69 AND 70  
FOR 2ND GABLE ASSEMBLY**

# STEP 71 - GABLE ASSEMBLY

QTY	PART NUMBER	DESCRIPTION
4	H100198	WASHER LOCK EXT 8x19
4	H100379	TNUT-5/16" BLK
4	H100405	WASHER LOCK EXT 6x15
4	H100456	LAG SCREW WH 1/4x2 1/2 BLK
4	H100777	SCREW PFH 10x3 1/2 BLK
4	H100974	BOLT WH 5/16x5 3/4 BLK

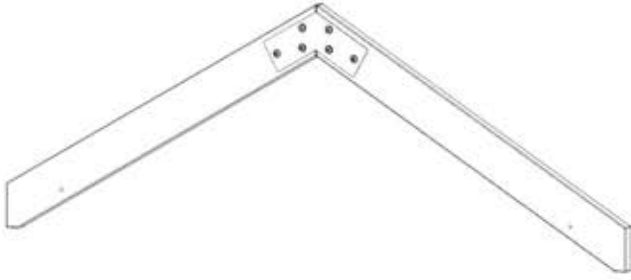

GABLE ASSEMBLY (x2) - FROM PREVIOUS STEPS

**- INSERT T-NUTS FIRST**

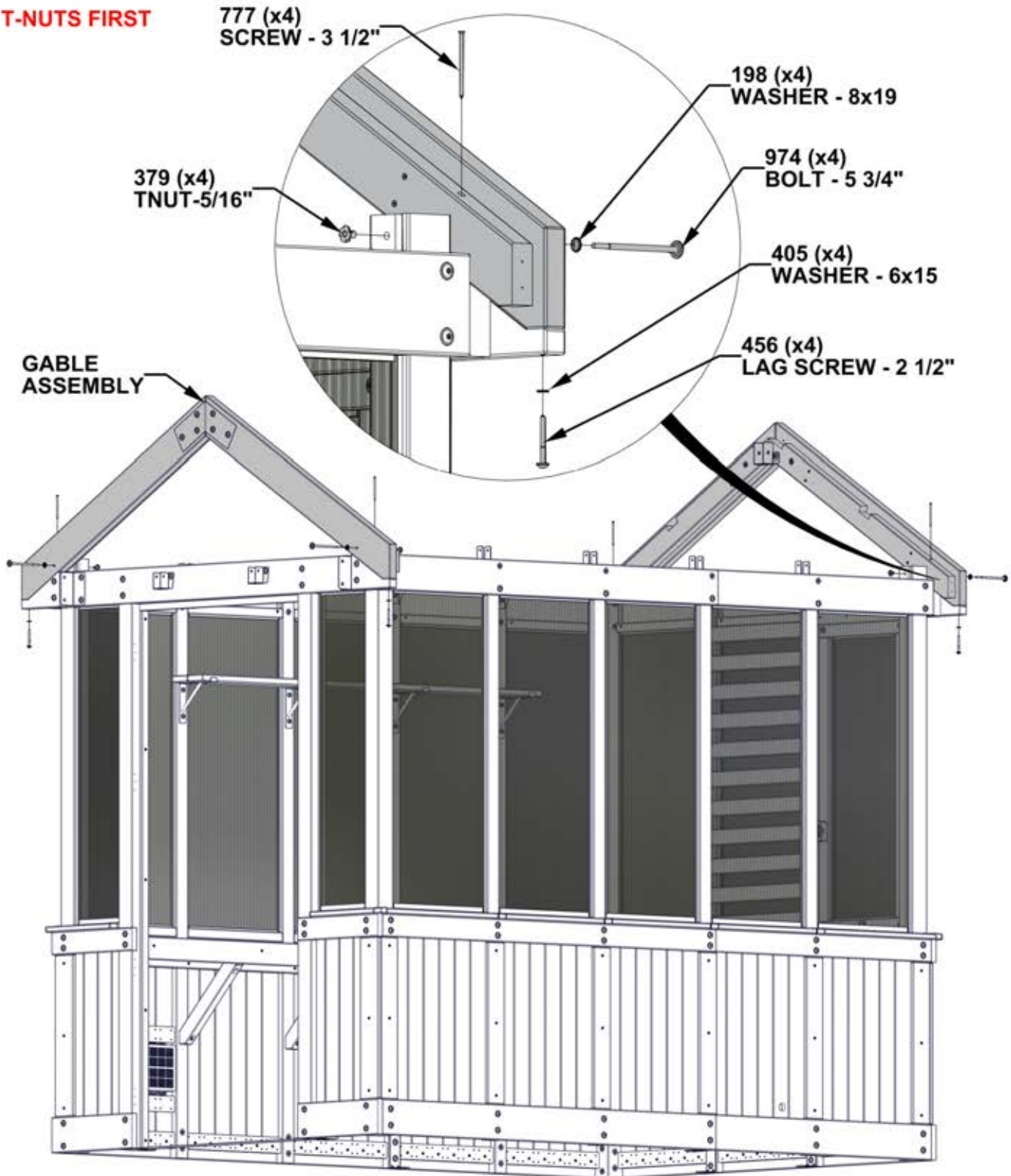

# STEP 72 - WINDOW ASSEMBLY

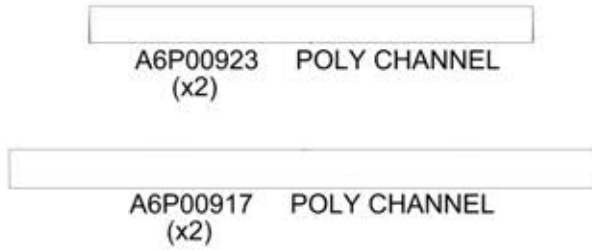

## TO APPLY DUST SEAL TAPE AND POLY CHANNEL:

- CUT 2 STRIPS OF DUST SEAL TAPE THE SAME WIDTH AS THE POLY SHEET.
- WRAP DUST SEAL TAPE ALONG EDGE OF POLY SHEET WIDTH.
- AFTER TAPE IS SECURE, PUSH CHANNEL ON OVER THE TAPE, CENTERING ON THE POLY SHEET.
- REPEAT ON THE BOTTOM SIDE OF POLY SHEET.
- ATTACH 0917 POLY CHANNEL ON SIDES.

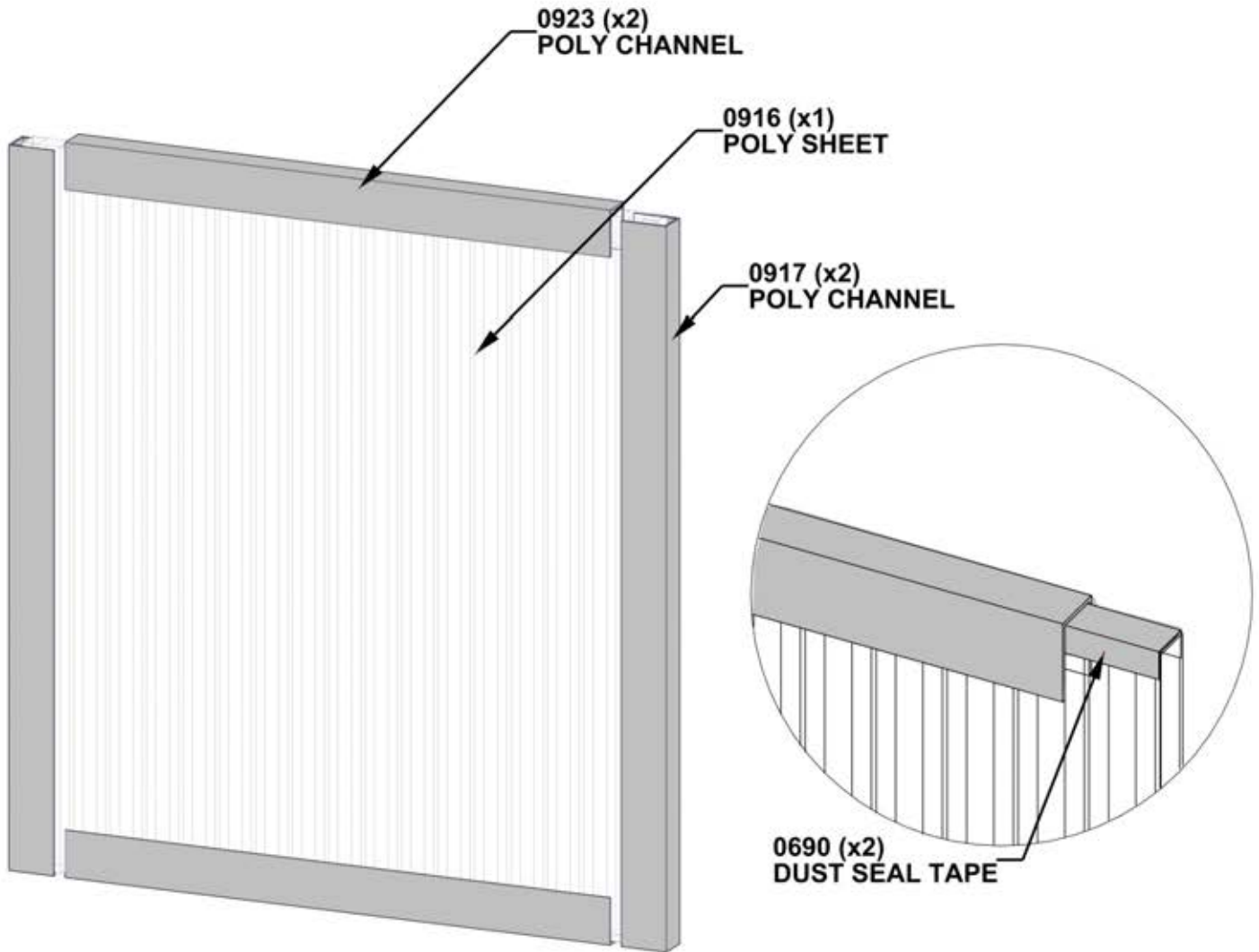

# STEP 73 - WINDOW ASSEMBLY

QTY	PART NUMBER	DESCRIPTION
4	H101109	SCREW PFH 8x3-1/2 BLK



F04 WINDOW FRAME - W4L20115  
(x1) 1 7/16"x2 3/8"x16 5/8" (36x60x422)



F05 WINDOW FRAME - W4L20116  
(x1) 1 7/16"x2 3/8"x16 5/8" (36x60x422)



F06 WINDOW FRAME - W4L20058  
(x1) 1 7/16"x2 3/8"x10 9/16" (36x60x268)



F07 WINDOW FRAME - W4L20056  
(x1) 1 7/16"x2 3/8"x10 9/16" (36x60x268)

**REMOVE TAPE LINER ON POLY CHANNELS BEFORE INSTALLING.**

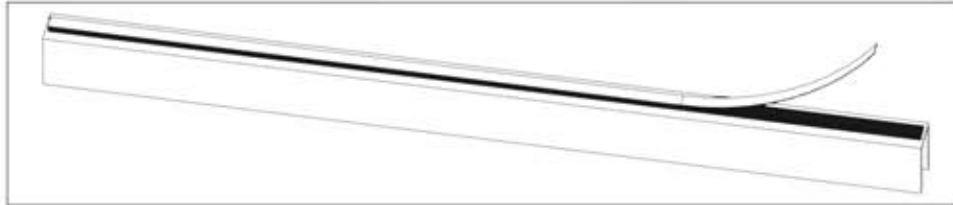

**- FIRMLY PUSH BOARDS ON ENSURING THE WINDOW ASSEMBLY SLIDES ALL THE WAY INTO THE GROOVES.**

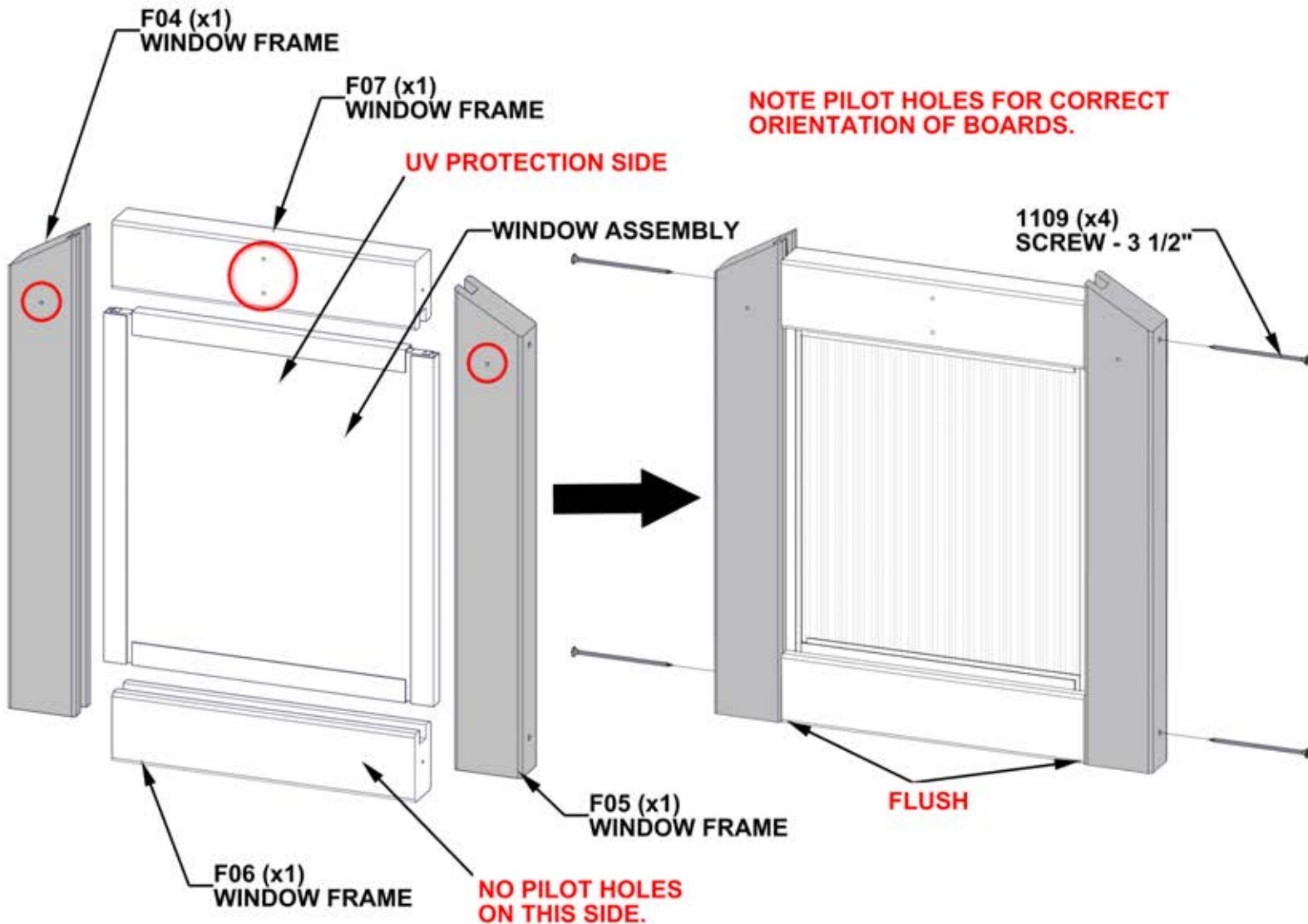

# STEP 74 - WINDOW ASSEMBLY

QTY	PART NUMBER	DESCRIPTION
16	H100385	SCREW PFH 8x1 BLK



A4M02099 T-CLEAT  
(x4)

ATTACH CLEATS USING PILOT HOLES IN WINDOW ASSEMBLY.

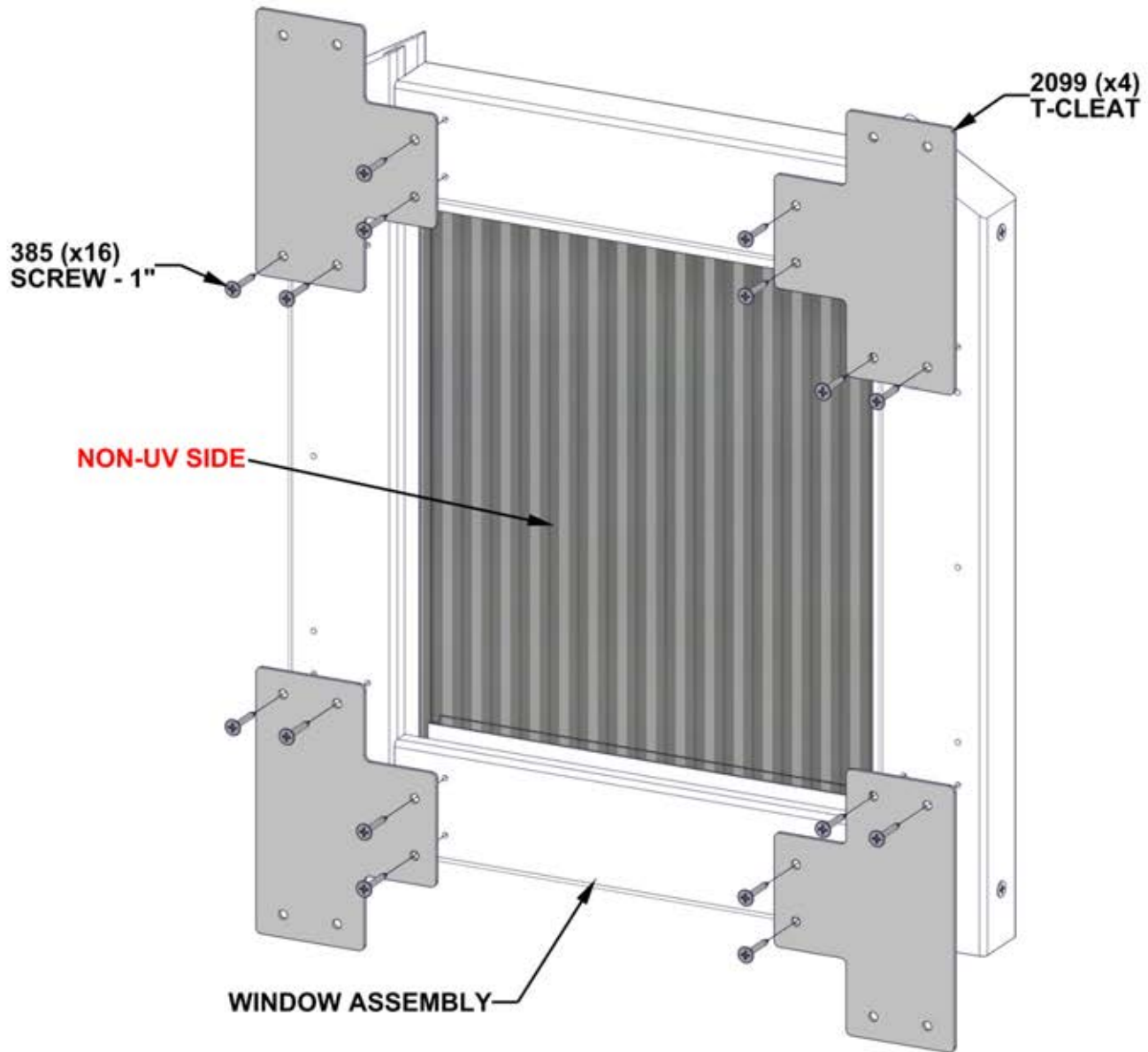

# STEP 75 - GABLE ASSEMBLY

QTY	PART NUMBER	DESCRIPTION
8	H100385	SCREW PFH 8x1 BLK

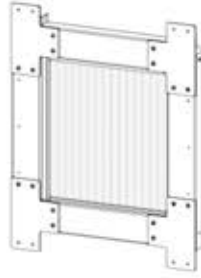

WINDOW ASSEMBLY - FROM STEP 74

- ALIGN PILOT HOLES IN HEADER WITH BOTTOM CLEAT HOLES.
- USE TOP CLEAT HOLES AS A GUIDE TO DRILL PILOT HOLES IN GABLE USING A 1/8" [3mm] DRILL BIT.
- ATTACH AS SHOWN.

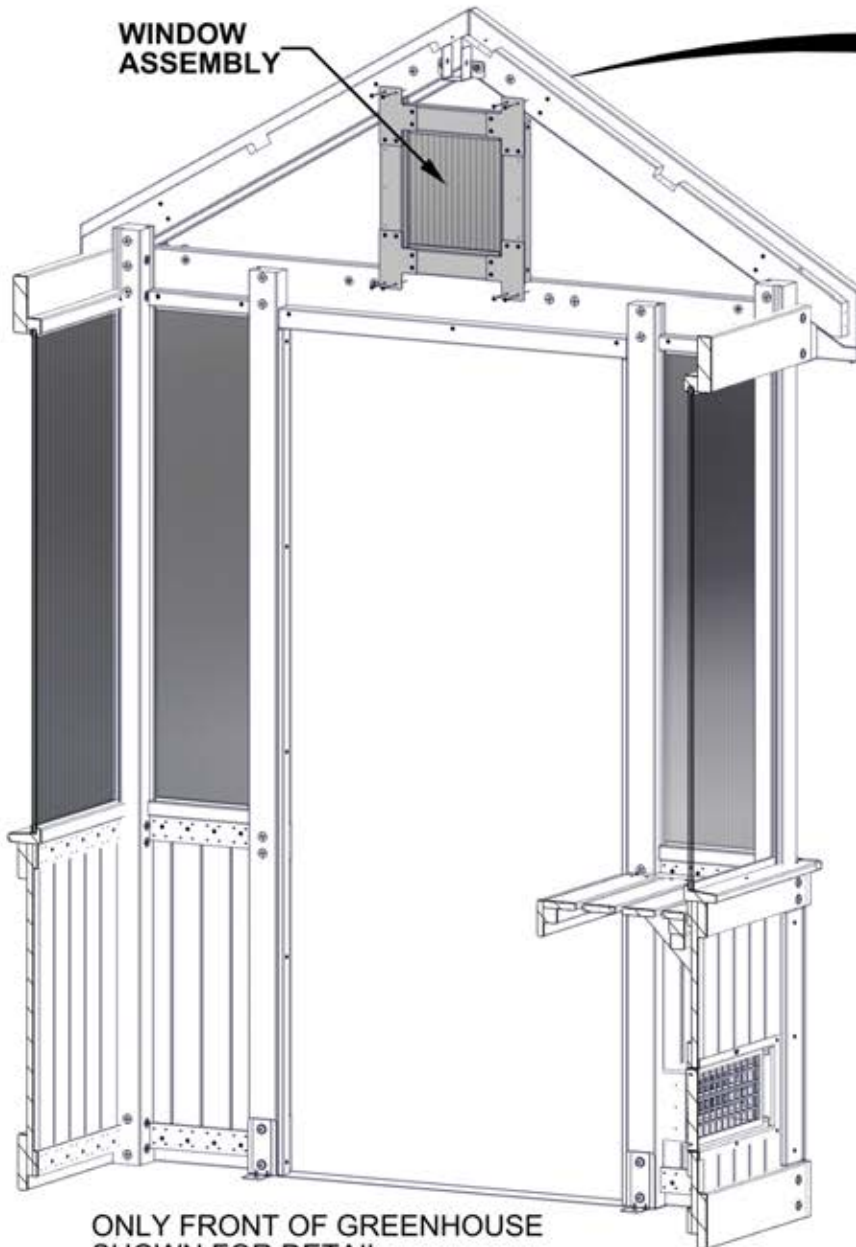

WINDOW ASSEMBLY

ONLY FRONT OF GREENHOUSE SHOWN FOR DETAIL.

385 (x8)  
SCREW - 1"

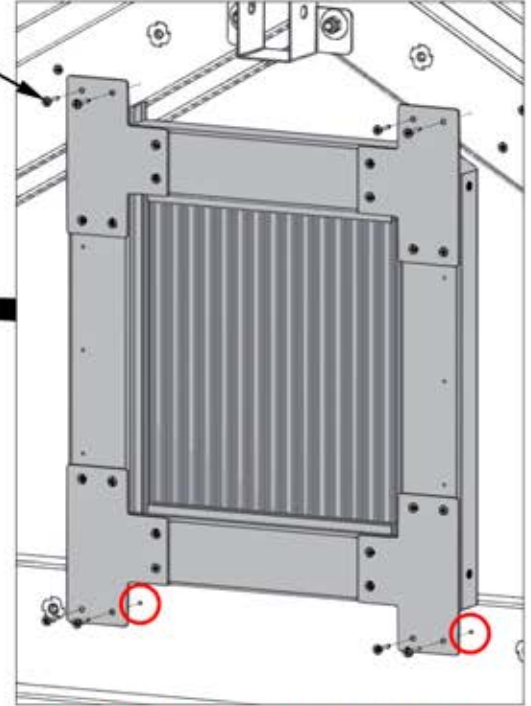

**ATTACH WINDOW ASSEMBLY  
USNG PILOT HOLES IN HEADER.**

# STEP 76 - GABLE ASSEMBLY

QTY	PART NUMBER	DESCRIPTION
4	H100200	SCREW PFH 8x1 1/2 BLK



K01 PEAK TRIM - W4L20060  
(x1) 5/8"x5 1/4"x15 1/4" (16x134x388)

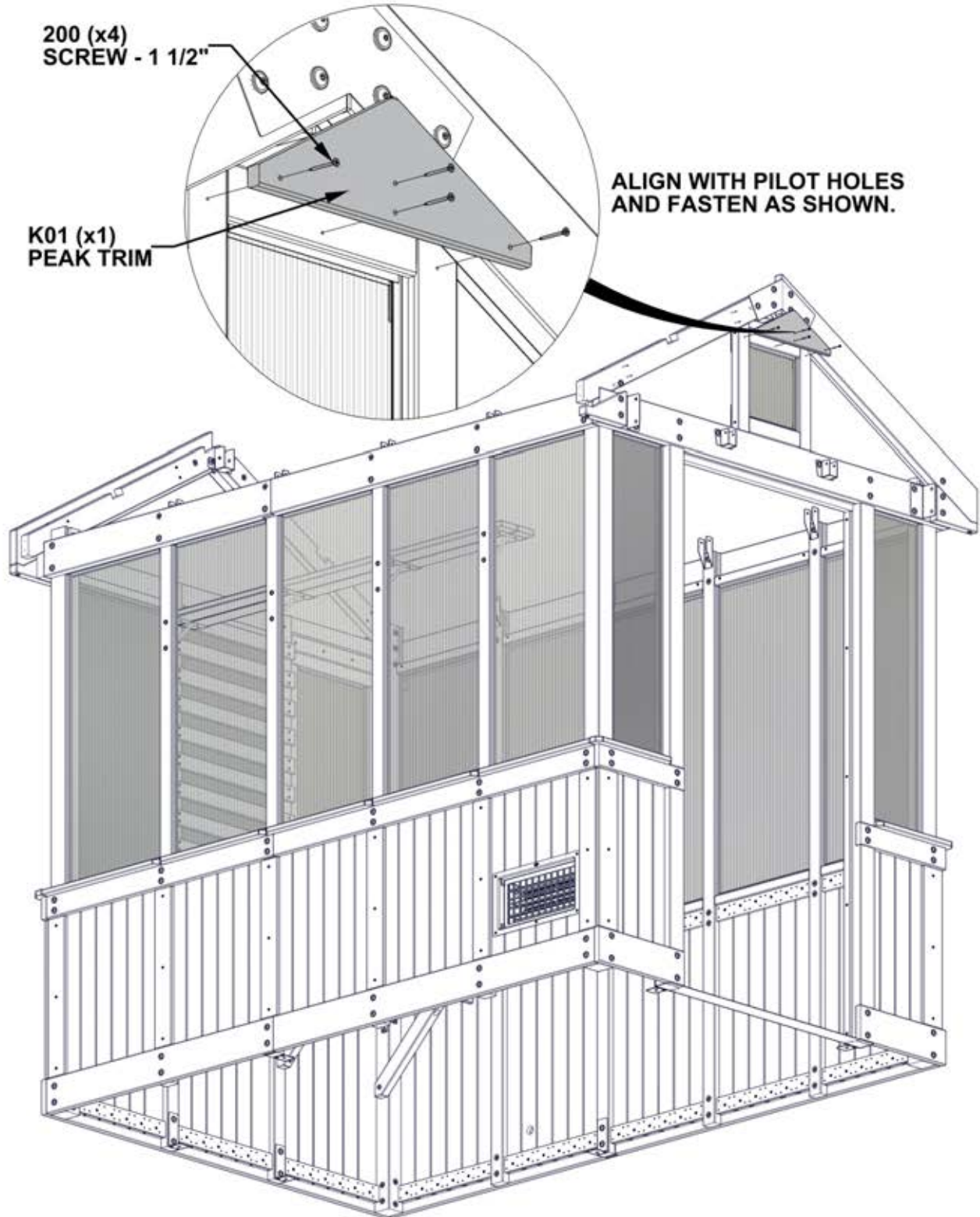

# STEP 77 - GABLE ASSEMBLY



WA01 WINDOW ASSEMBLY - W2A04327  
(x1) 1 7/16"x15 11/16"x24 3/4" (36x398x629)



WA02 WINDOW ASSEMBLY - W2A04328  
(x1) 1 7/16"x15 11/16"x24 3/4" (36x398x629)

SLIDE WINDOW ASSEMBLIES INTO OPENINGS UNTIL THEY CONTACT GABLE BOARDS.

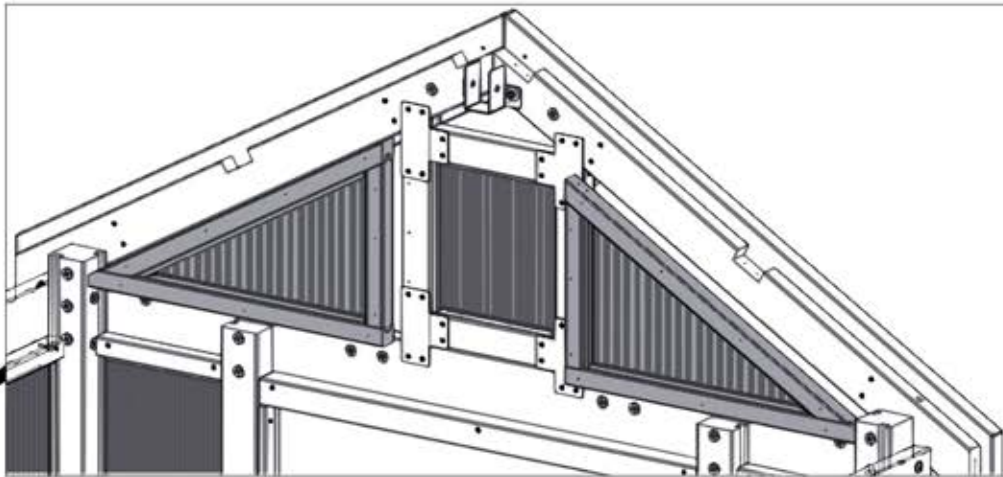

WA02 (x1)  
WINDOW ASSEMBLY

WA01 (x1)  
WINDOW ASSEMBLY

WINDOWS WILL BE FLUSH WITH FRONT OF GREENHOUSE.

GABLE BOARD

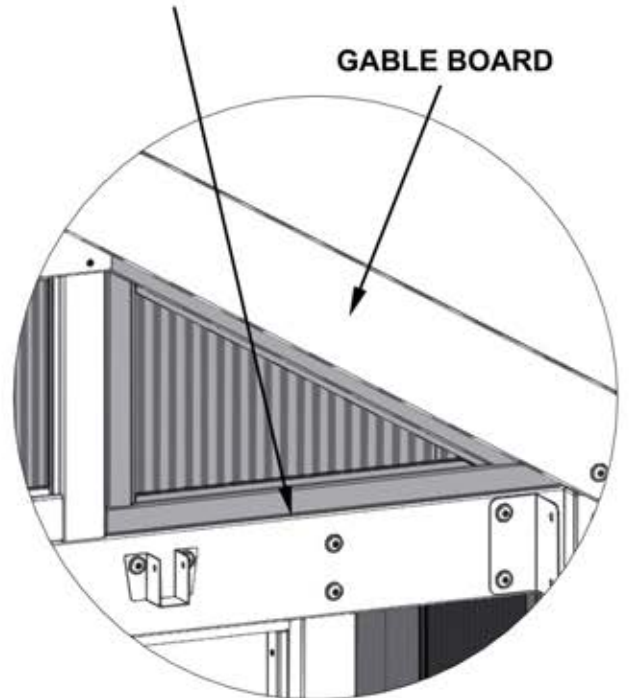

OUTSIDE VIEW



ONLY FRONT OF GREENHOUSE SHOWN FOR DETAIL.

# STEP 78 - GABLE ASSEMBLY

QTY	PART NUMBER	DESCRIPTION
40	H100382	SCREW PFH 8x1 3/4 BLK



N01 WINDOW TRIM - W4L20057  
(x2) 5/8"x2 3/8"x31 5/16" (16x60x796)



N02 WINDOW TRIM - W4L20054  
(x2) 5/8"x2 3/8"x13 3/16" (16x60x335)



N03 WINDOW TRIM - W4L20059  
(x2) 5/8"x2 3/8"x26" (16x60x660)

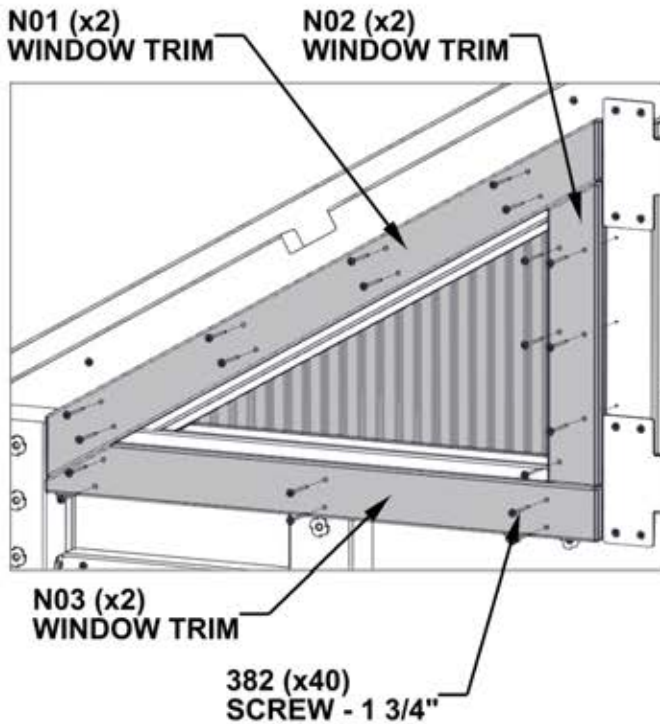

- **TWO ADULTS REQUIRED FOR THIS STEP: ONE TO HOLD WINDOW IN PLACE, ONE TO ATTACH TRIM.**
- INSTALL N02 BOARDS FIRST BY ALIGNING THROUGH HOLES IN BOARD WITH PILOT HOLES IN WINDOW ASSEMBLY AND WINDOW FRAME.
- REMAINING BOARDS BUTT UP AGAINST N02 AND ARE FLUSH ON THE OUTSIDE AS SHOWN.
- ALIGN HOLES ON N01 AND N03 WITH PILOT HOLES IN WINDOW AND ATTACH.
- USE AN 1/8" [3mm] DRILL BIT WITH N01 AND N03 AS GUIDES TO DRILL PILOT HOLES.
- ATTACH WITH REMAINING HARDWARE.

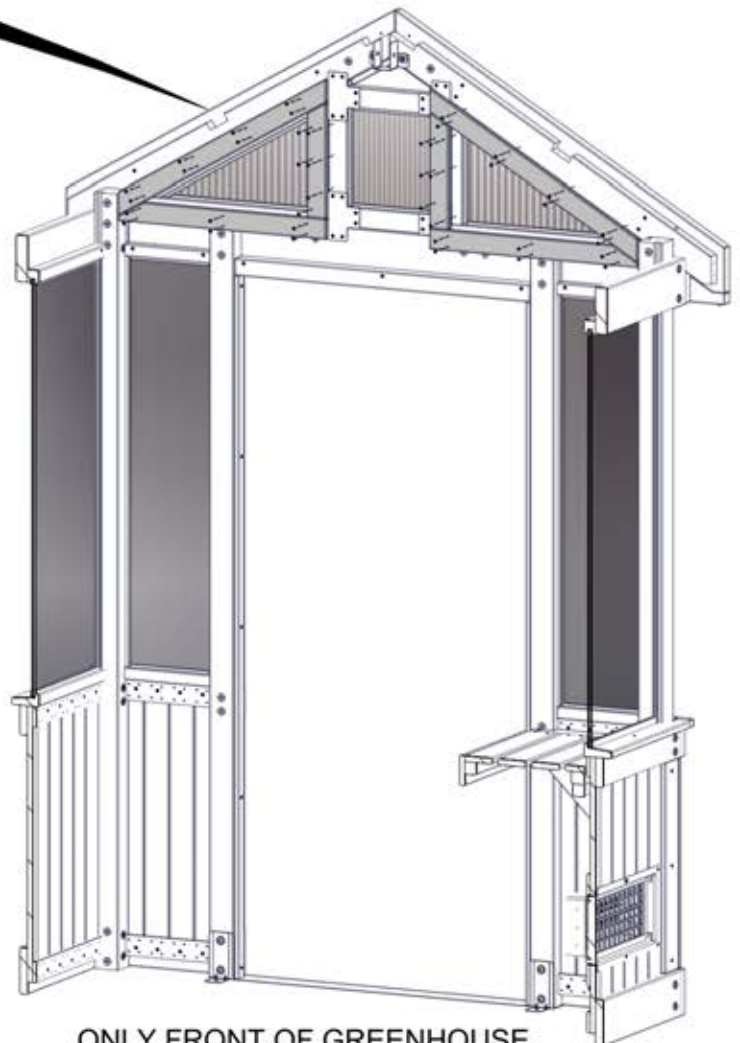

ONLY FRONT OF GREENHOUSE SHOWN FOR DETAIL.

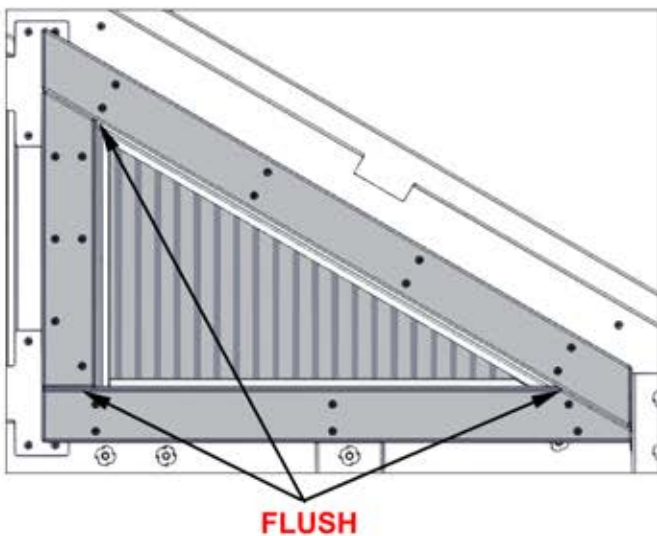

# STEP 79 - FAN SUPPORT ASSEMBLY

QTY	PART NUMBER	DESCRIPTION
6	H101109	SCREW PFH 8x3-1/2 BLK

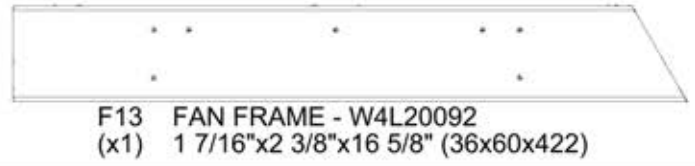
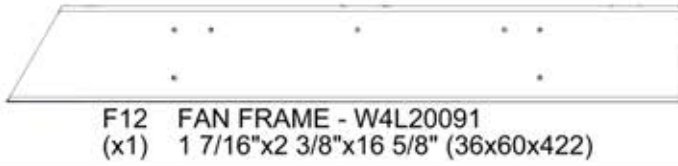
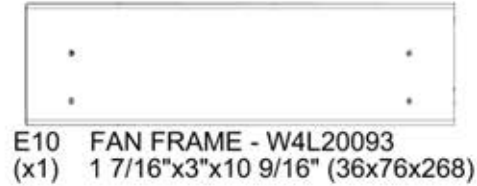
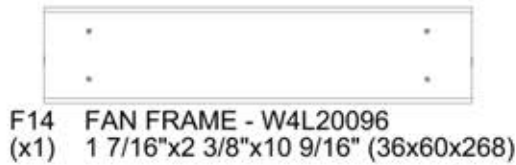

**NOTE PILOT HOLES FOR CORRECT ORIENTATION OF ALL BOARDS.**

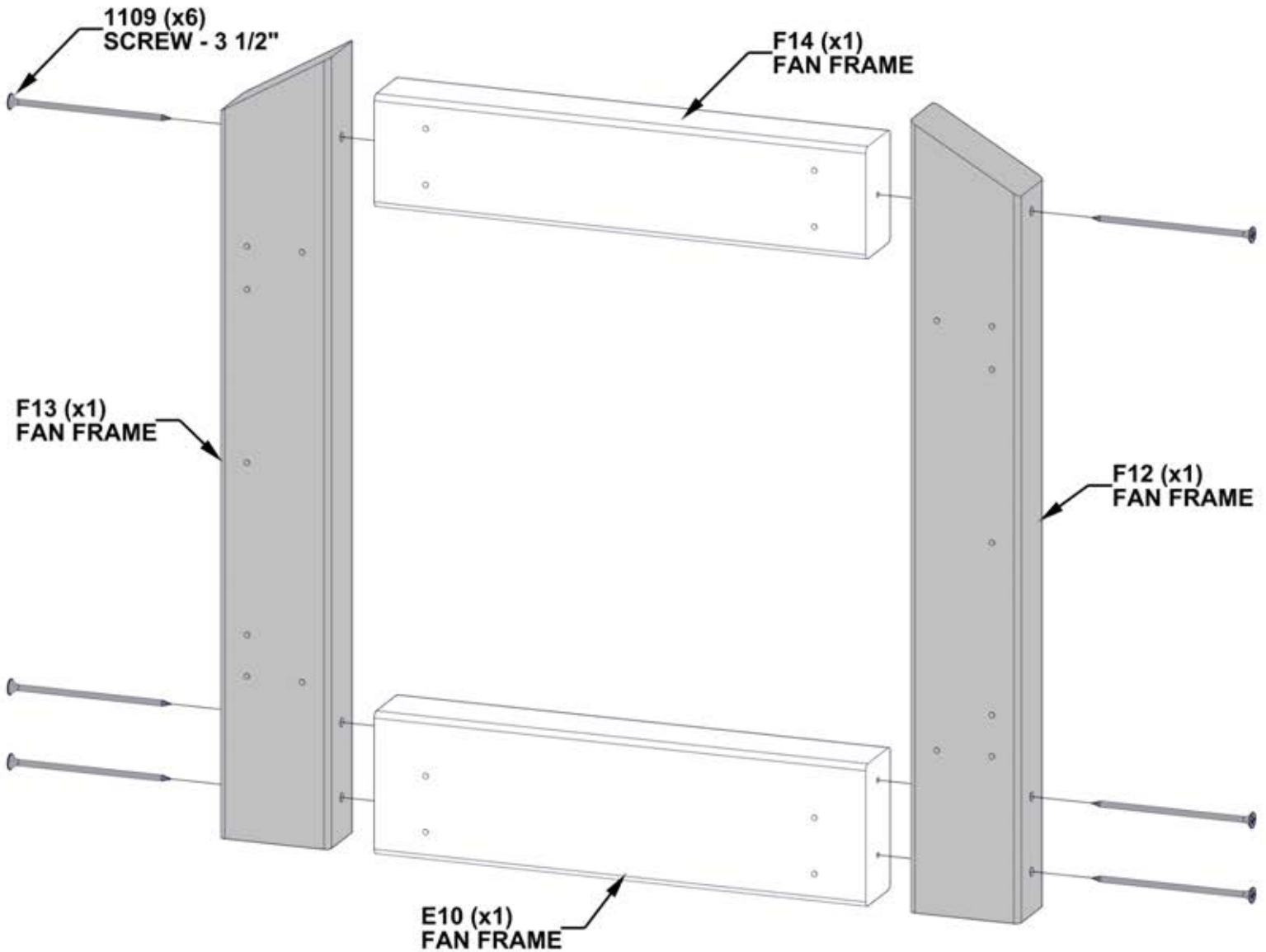

**ENSURE ASSEMBLY IS SQUARE BEFORE PROCEEDING.**

# STEP 80 - FAN SUPPORT ASSEMBLY

QTY	PART NUMBER	DESCRIPTION
16	H100385	SCREW PFH 8x1 BLK

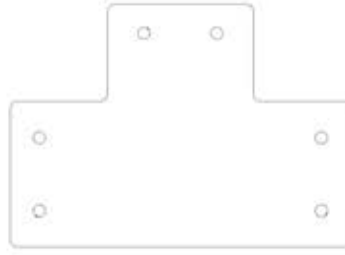

A4M02099 T-CLEAT  
(x4)

USE PILOT HOLES IN FAN SUPPORT ASSEMBLY TO ATTACH T-CLEATS.

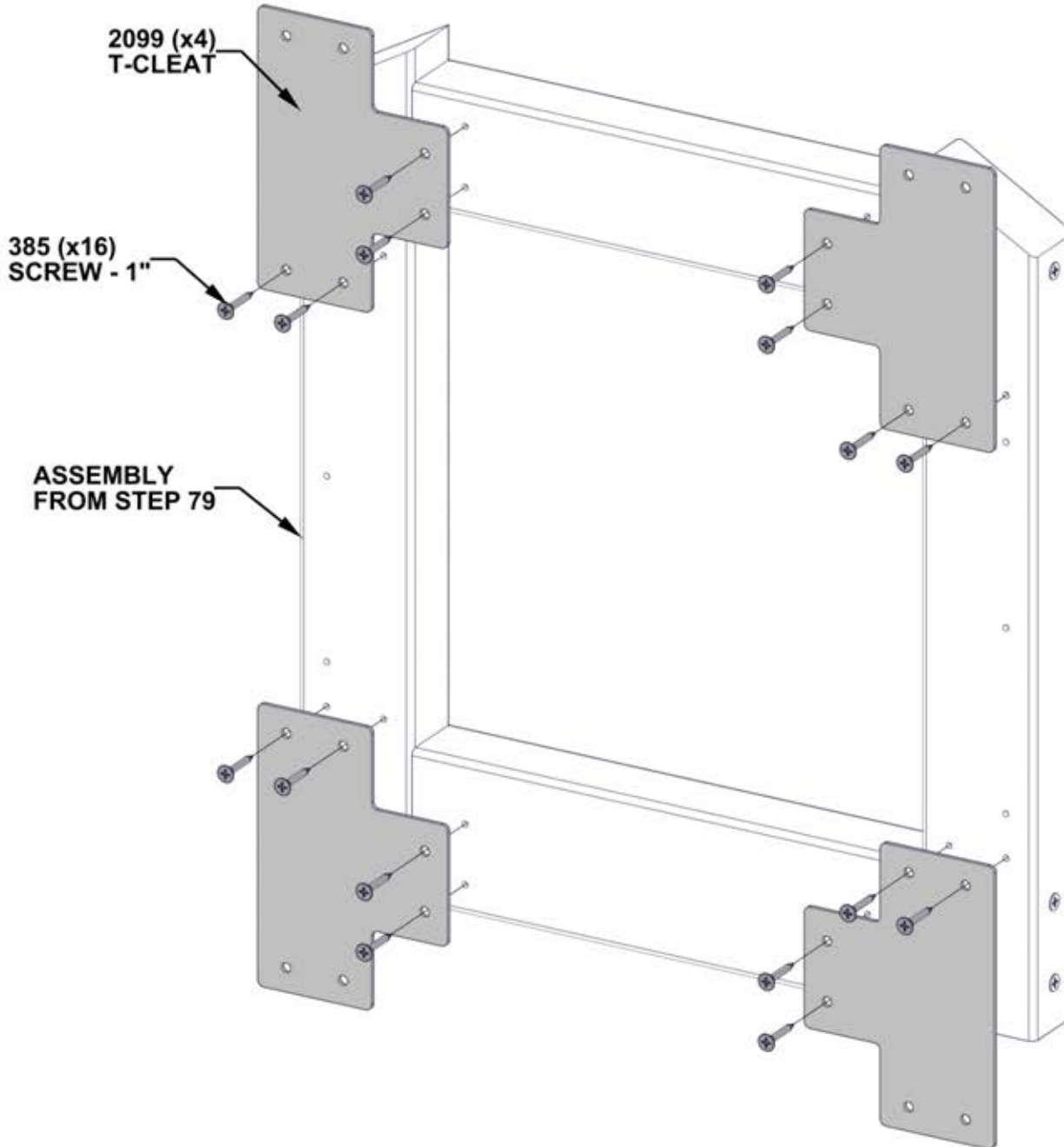

# STEP 81 - GABLE ASSEMBLY

QTY	PART NUMBER	DESCRIPTION
4	H100380	SCREW PFH 8x1 1/8 BLK
8	H100385	SCREW PFH 8x1 BLK

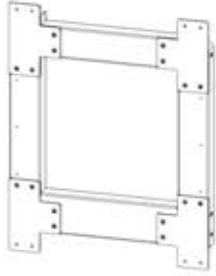

FAN SUPPORT ASSEMBLY  
- FROM STEP 80



N06 SLAT - W4L20089  
(x1) 5/8"x2 3/8"x25 3/8" (16x60x645)

- 1) INSTALL FAN SUPPORT ASSEMBLY FIRST  
- ALIGN PILOT HOLES IN HEADER WITH  
BOTTOM CLEAT HOLES  
- USE TOP CLEAT HOLES AS A GUIDE TO  
DRILL PILOT HOLES IN GABLE USING 1/8"  
[3mm] DRILL BIT.  
- ATTACH AS SHOWN

- 2) ATTACH N06 SLAT AS SHOWN.

385 (x8)  
SCREW - 1"

FAN SUPPORT  
ASSEMBLY

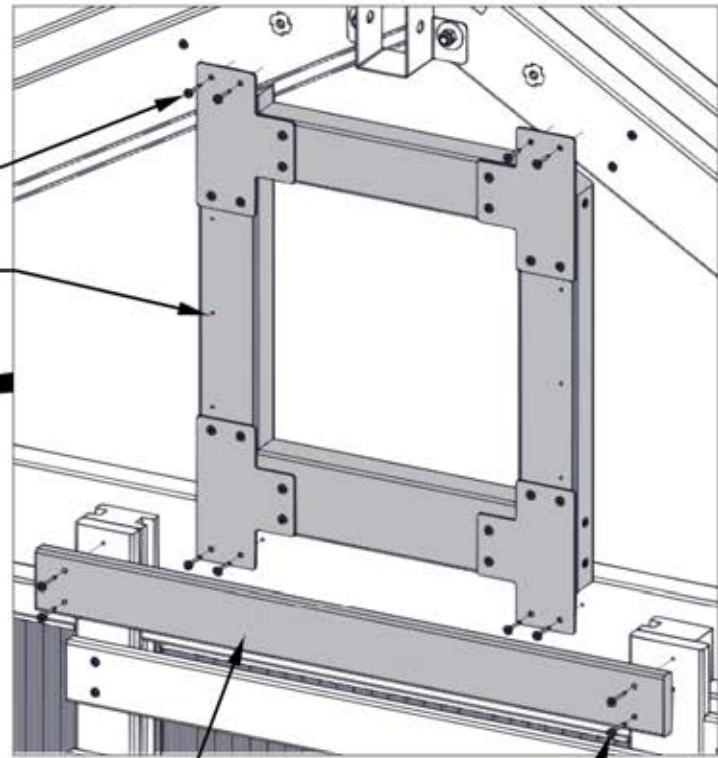

N06 (x1)  
SLAT

380 (x4)  
SCREW - 1 1/8"

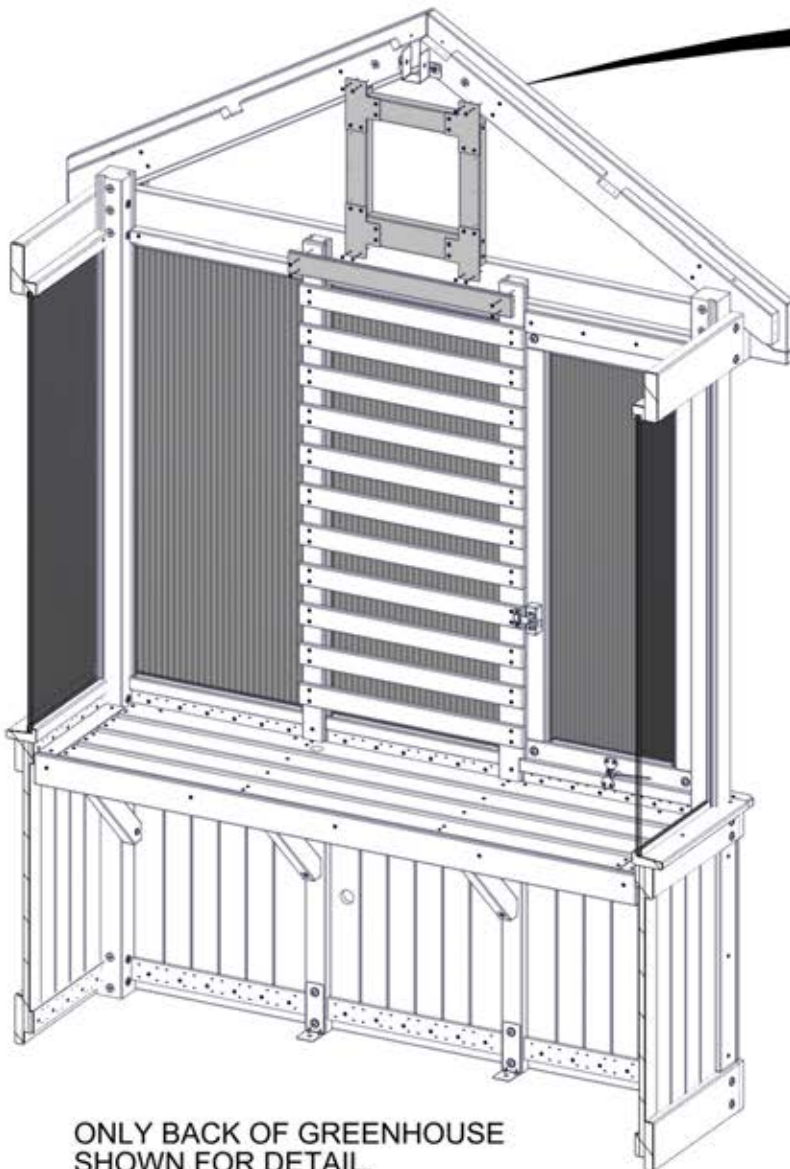

ONLY BACK OF GREENHOUSE  
SHOWN FOR DETAIL.

# STEP 82 - FAN ASSEMBLY

QTY	PART NUMBER	DESCRIPTION
8	H101207	SCREW PWH 8x15x7/8 BLK

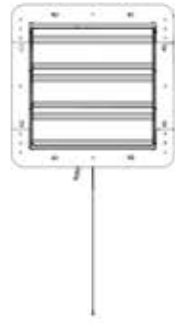

A4M02383 EXHAUST FAN (x1)

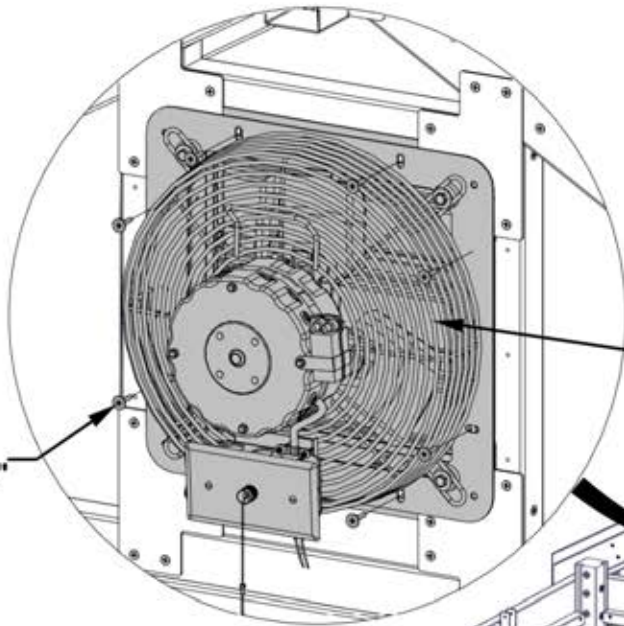

CENTER EXHAUST FAN IN THE OPENING AND ATTACH AS SHOWN.

2383 (x1) EXHAUST FAN

1207 (x8) SCREW - 7/8"

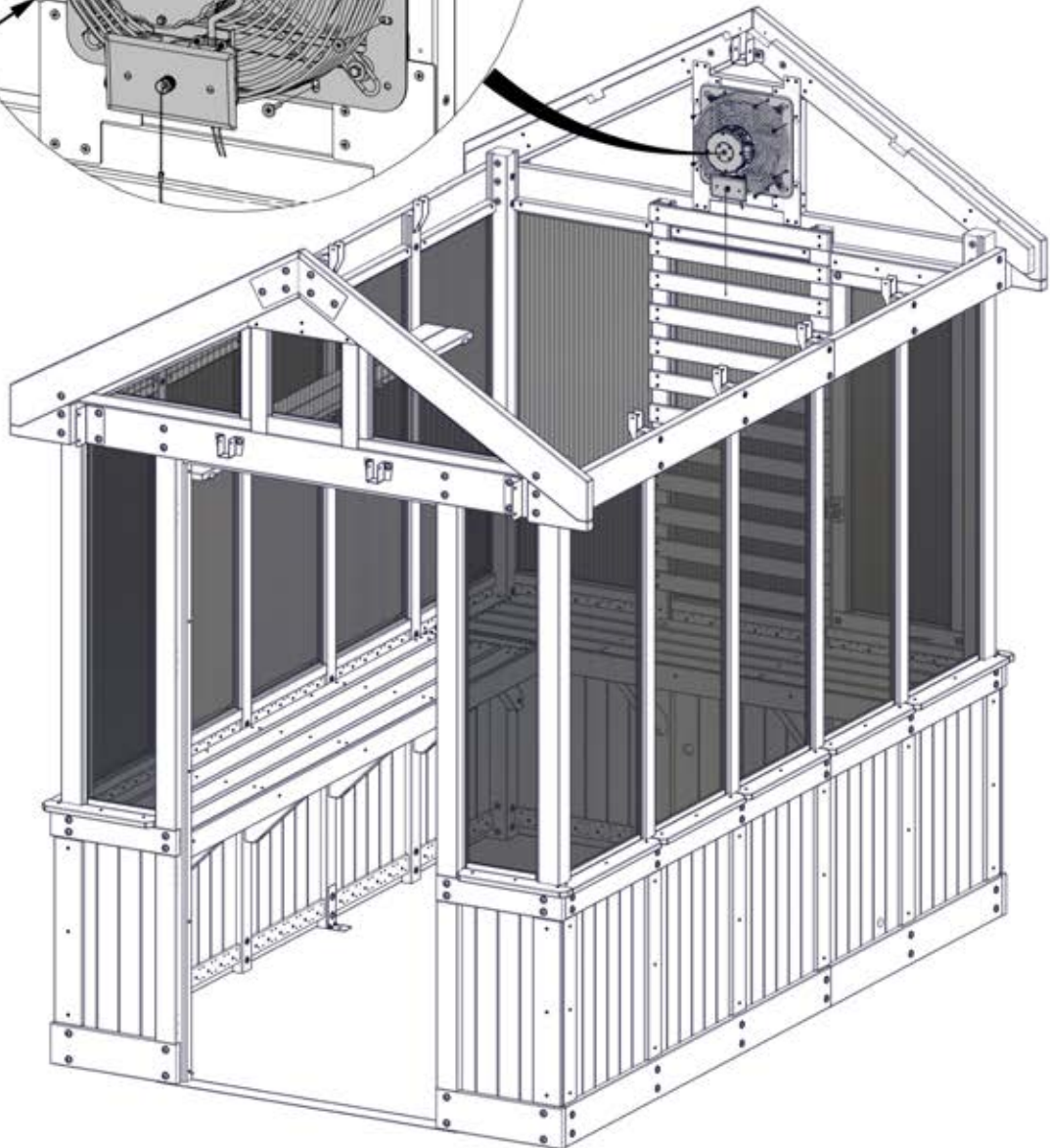

# STEP 83 - GABLE ASSEMBLY

QTY	PART NUMBER	DESCRIPTION
10	H100200	SCREW PFH 8x1 1/2 BLK

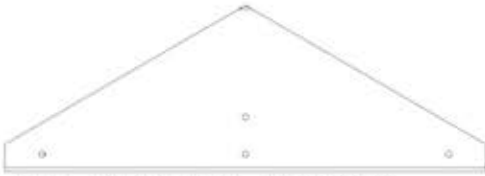

**K01 PEAK TRIM - W4L20060**  
(x1) 5/8"x5 1/4"x15 1/4" (16x134x388)



**N08 FAN TRIM - W4L20097**  
(x2) 5/8"x2 3/8"x10 9/16" (16x60x268)



**N09 FAN TRIM - W4L20098**  
(x1) 5/8"x2 3/8"x15 1/4" (16x60x388)

**ALIGN PILOT HOLES AND ATTACH AS SHOWN.**

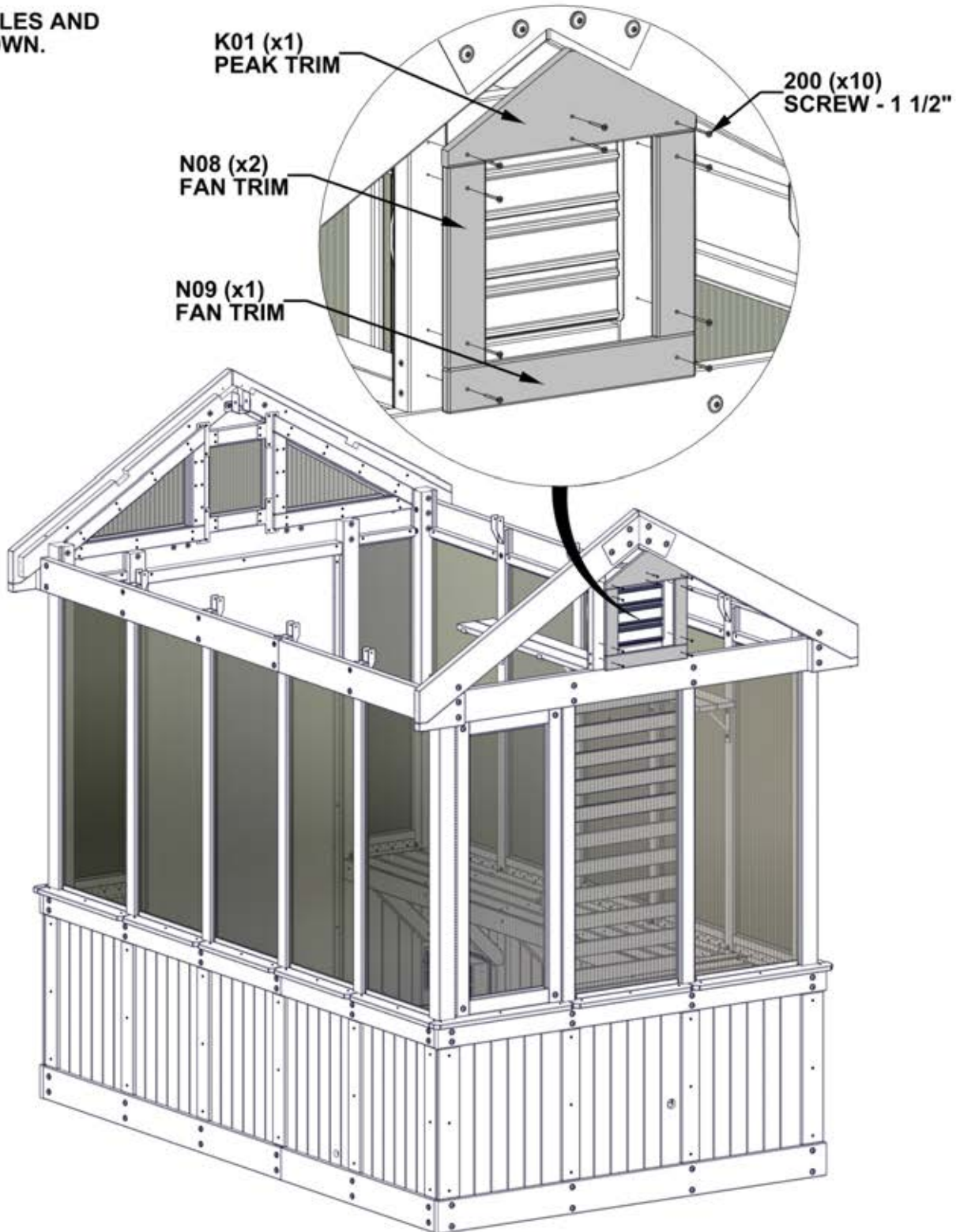

# STEP 84 - GABLE ASSEMBLY



WA01 WINDOW ASSEMBLY - W2A04327  
(x1) 1 7/16"x15 11/16"x24 3/4" (36x398x629)



WA02 WINDOW ASSEMBLY - W2A04328  
(x1) 1 7/16"x15 11/16"x24 3/4" (36x398x629)

**SLIDE WINDOW ASSEMBLIES INTO OPENINGS UNTIL THEY CONTACT GABLE BOARDS.**

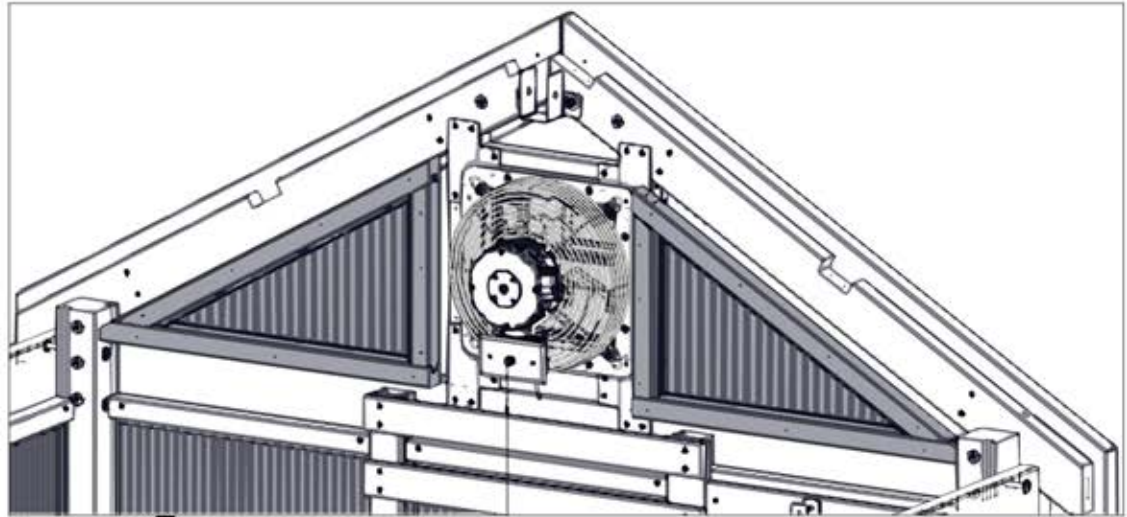

WA02 (x1)  
WINDOW ASSEMBLY

WA01 (x1)  
WINDOW ASSEMBLY

**WINDOWS WILL BE FLUSH WITH BACK OF GREENHOUSE.**

GABLE BOARD

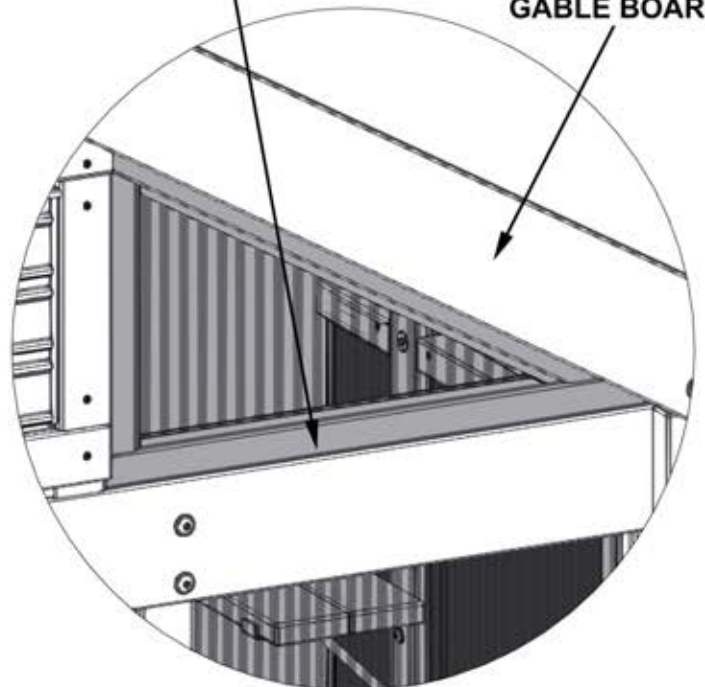

OUTSIDE VIEW

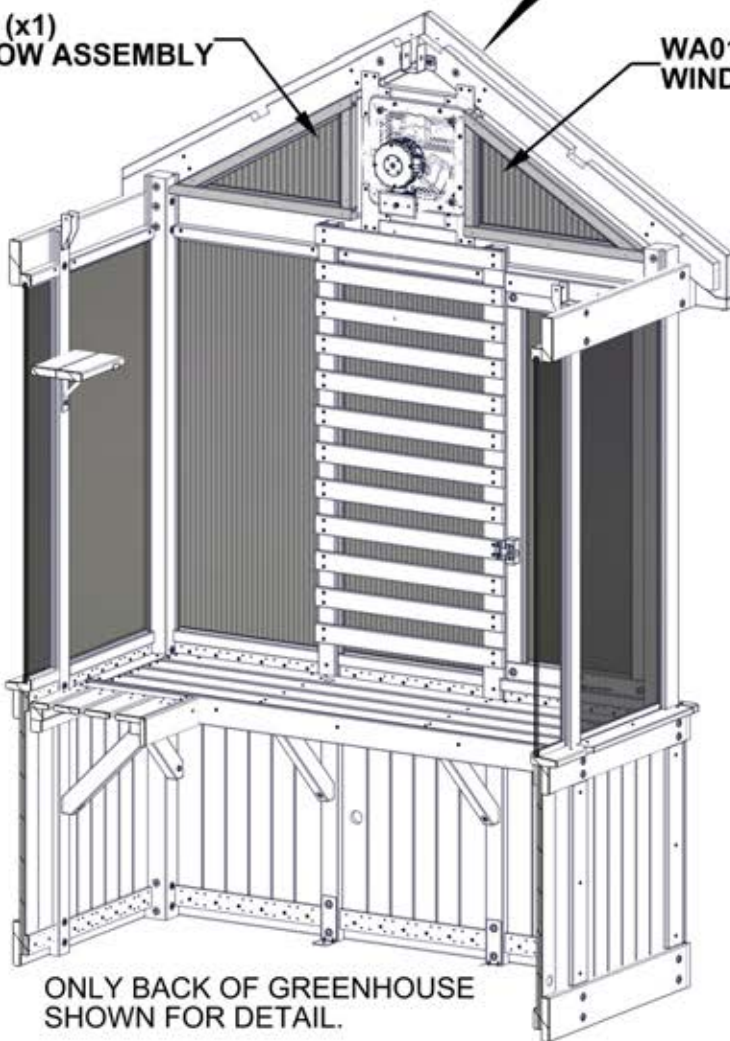

ONLY BACK OF GREENHOUSE SHOWN FOR DETAIL.

# STEP 85 - GABLE ASSEMBLY

QTY	PART NUMBER	DESCRIPTION
40	H100382	SCREW PFH 8x1 3/4 BLK



N01 WINDOW TRIM - W4L20057  
(x2) 5/8"x2 3/8"x31 5/16" (16x60x796)



N02 WINDOW TRIM - W4L20054  
(x2) 5/8"x2 3/8"x13 3/16" (16x60x335)



N03 WINDOW TRIM - W4L20059  
(x2) 5/8"x2 3/8"x26" (16x60x660)

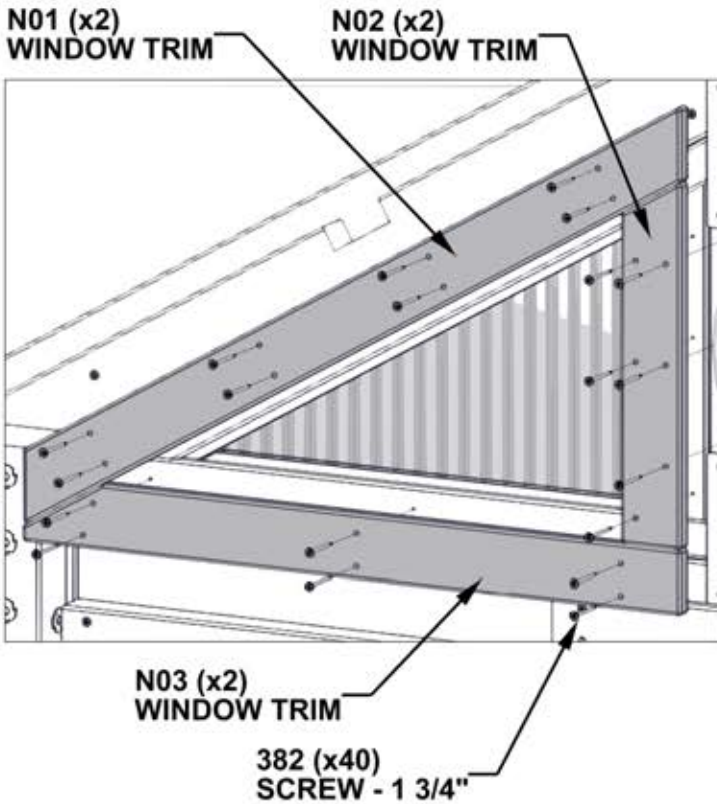

- **TWO ADULTS REQUIRED FOR THIS STEP: ONE TO HOLD WINDOW IN PLACE, ONE TO ATTACH TRIM.**
- INSTALL N02 BOARDS FIRST BY ALIGNING THROUGH HOLES IN BOARD WITH PILOT HOLES IN WINDOW ASSEMBLY AND WINDOW FRAME.
- REMAINING BOARDS BUTT UP AGAINST N02 AND ARE FLUSH ON THE OUTSIDE AS SHOWN.
- ALIGN HOLES ON N01 AND N03 WITH PILOT HOLES IN WINDOW AND ATTACH.
- USE AN 1/8" [3mm] DRILL BIT WITH N01 AND N03 AS GUIDES TO DRILL PILOT HOLES.
- ATTACH WITH REMAINING HARDWARE.

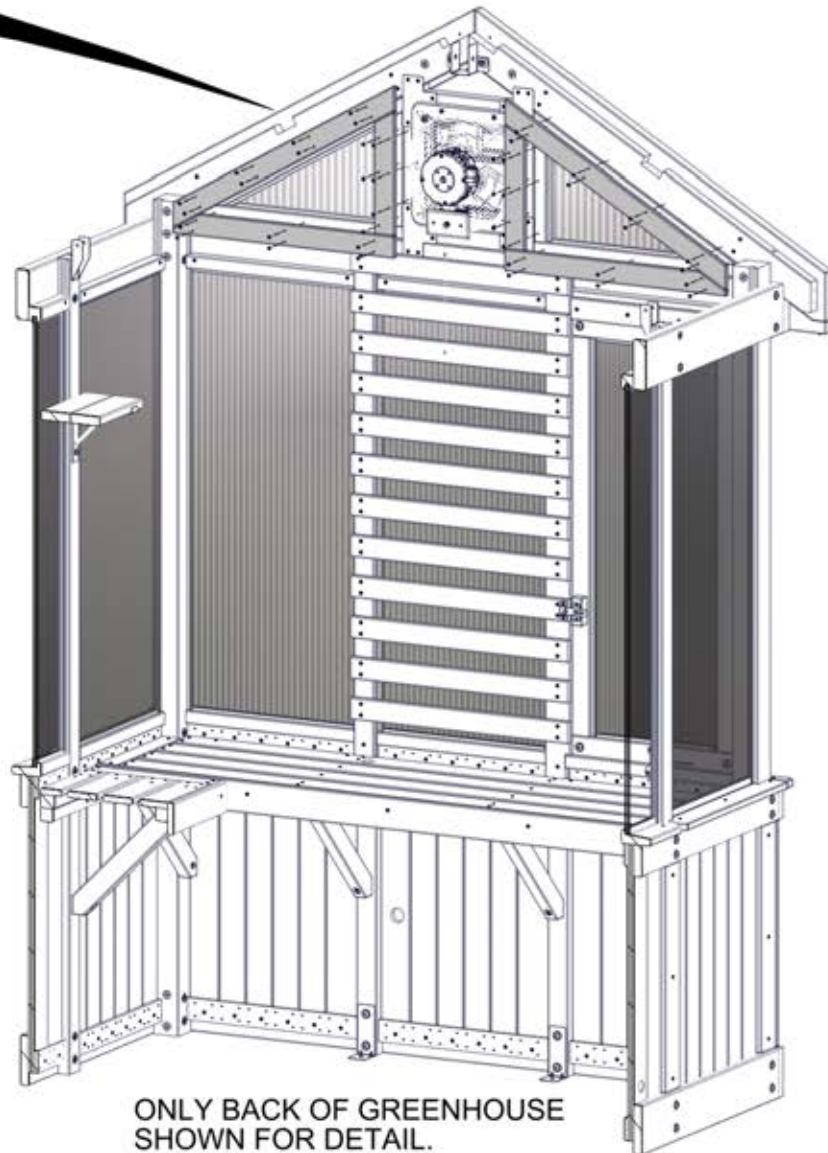
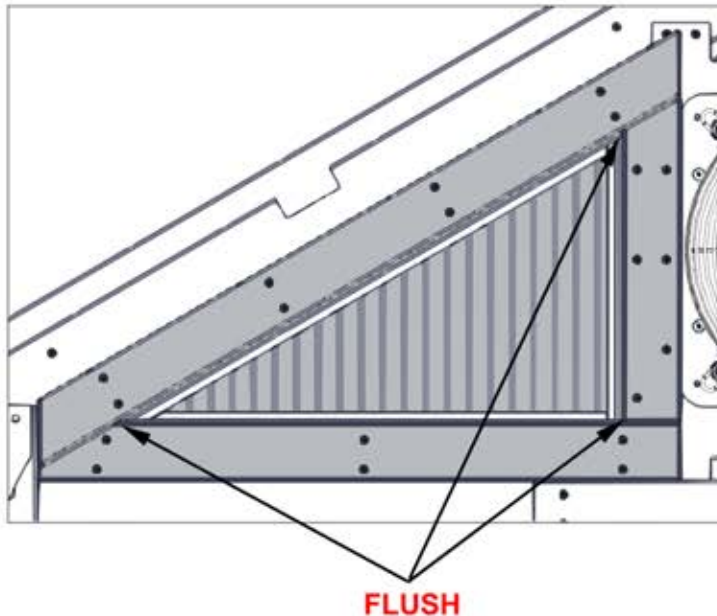

ONLY BACK OF GREENHOUSE SHOWN FOR DETAIL.

# STEP 86 - ROOF ASSEMBLY

QTY	PART NUMBER	DESCRIPTION
8	H100391	SCREW PFH 8x2 BLK

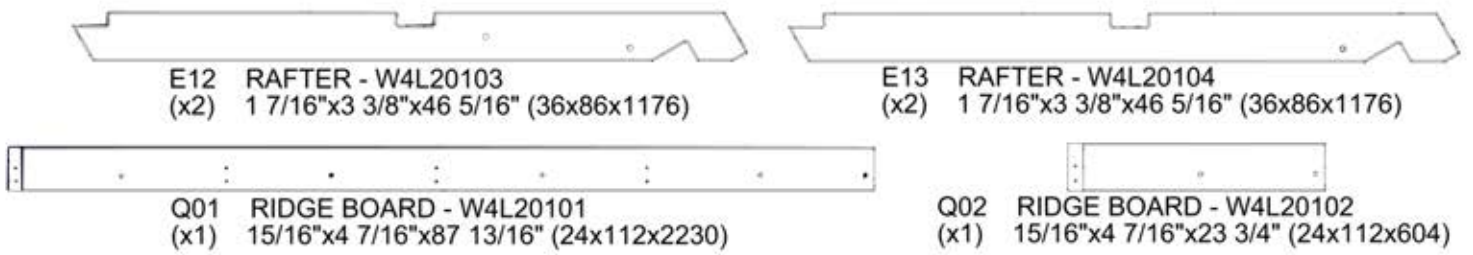

## IMPORTANT!

**NOTE ALL NOTCH DIRECTIONS AND BOARD PLACEMENT FOR CORRECT ASSEMBLY.**

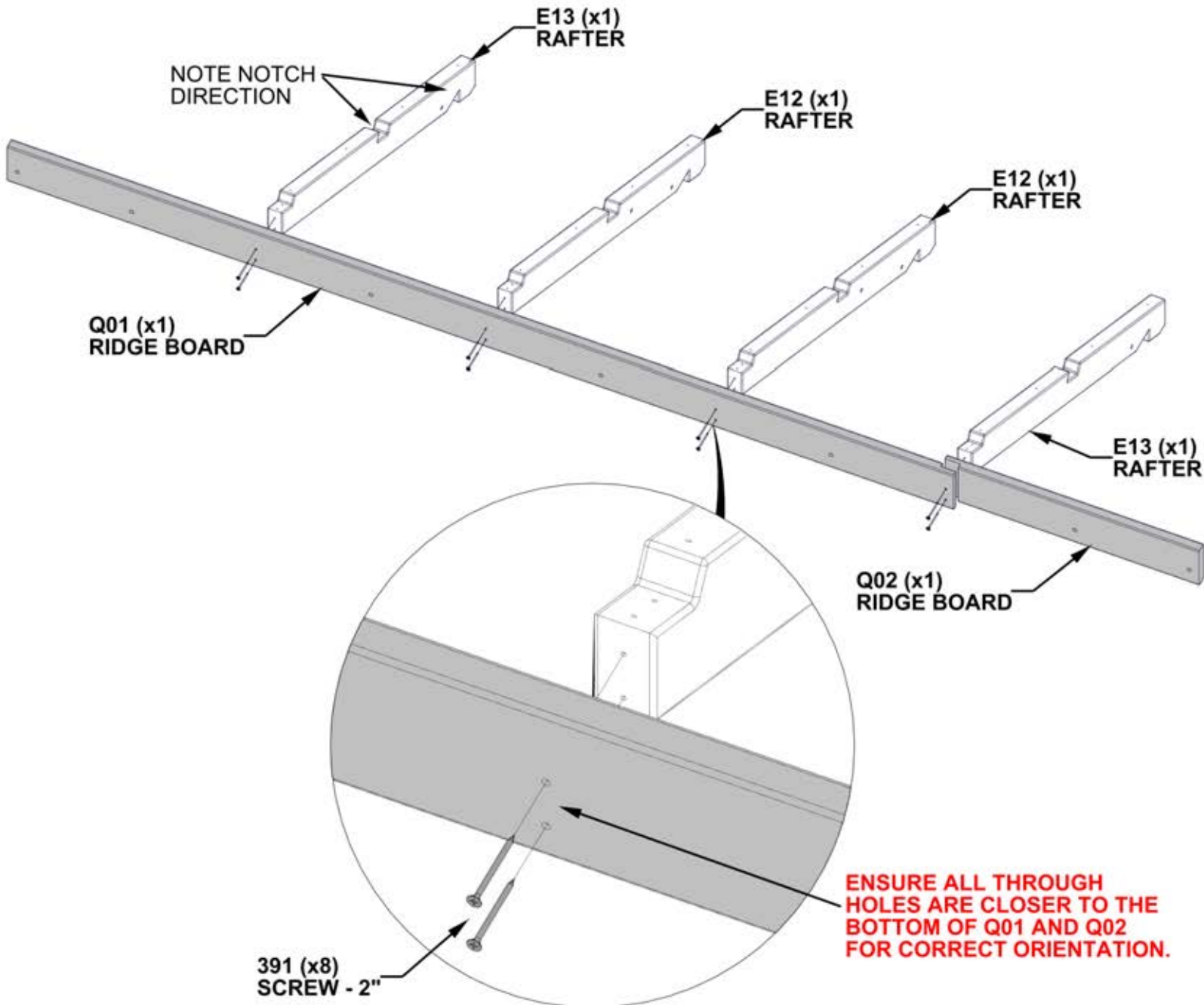

# STEP 87 - ROOF ASSEMBLY

QTY	PART NUMBER	DESCRIPTION
4	H100200	SCREW PFH 8x1 1/2 BLK
12	H100391	SCREW PFH 8x2 BLK

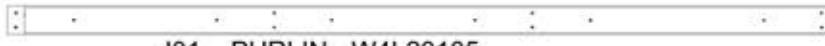

J01 PURLIN - W4L20105  
(x1) 15/16"x2 3/8"x67 15/16" (24x60x1725)

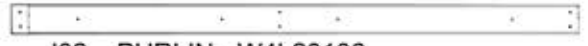

J02 PURLIN - W4L20106  
(x1) 15/16"x2 3/8"x46 9/16" (24x60x1183)

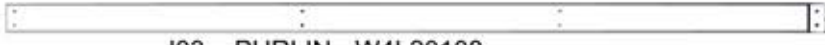

J03 PURLIN - W4L20108  
(x1) 15/16"x2 3/8"x67 15/16" (24x60x1725)

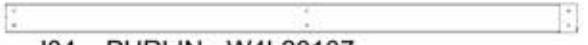

J04 PURLIN - W4L20107  
(x1) 15/16"x2 3/8"x46 9/16" (24x60x1183)

- ATTACH PURLINS USING PILOT HOLES IN RAFTERS.
- USE SHORTER SCREWS ON TOP ROW ONLY.

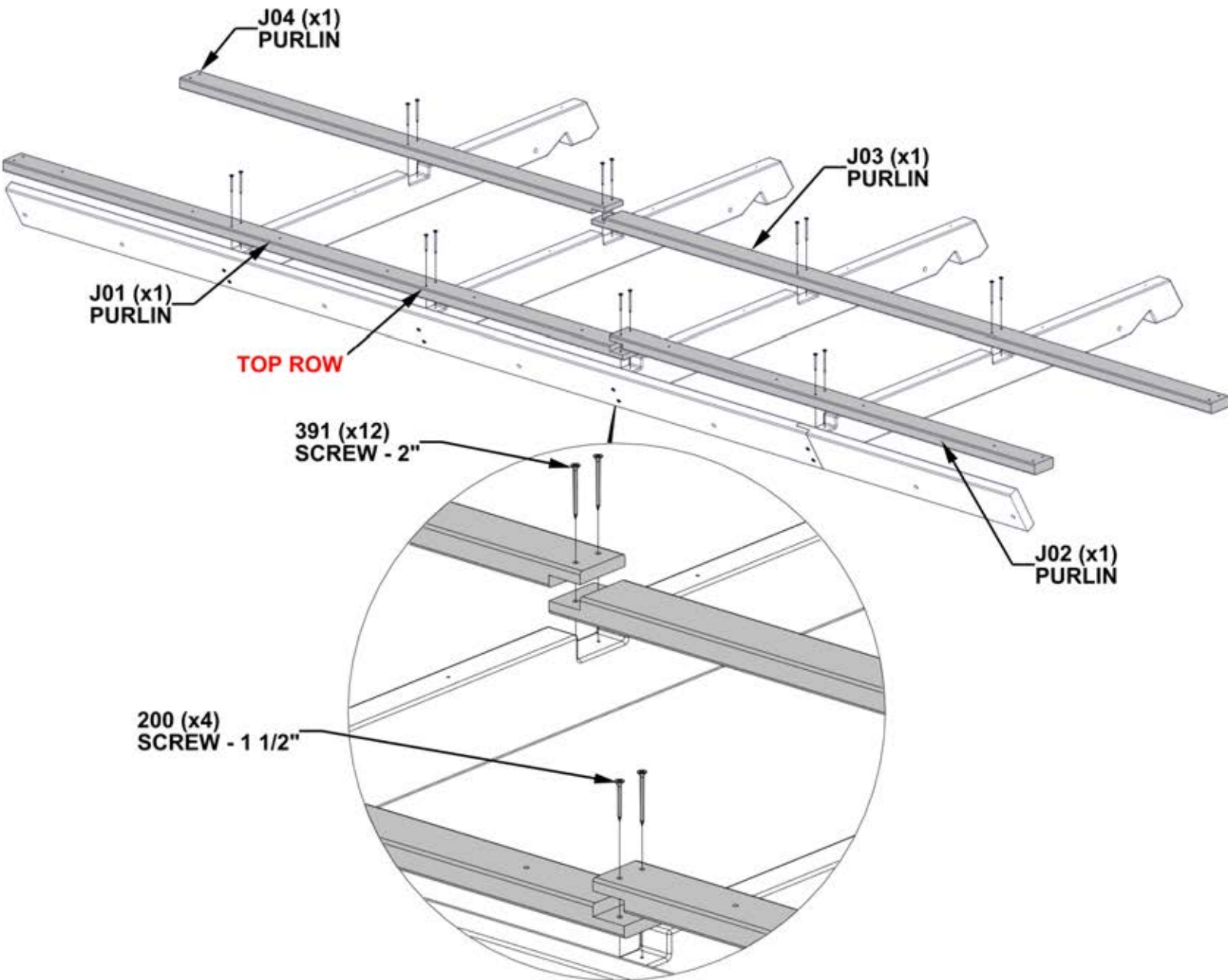

## STEP 88 - ROOF ASSEMBLY

### IMPORTANT!

#### BEFORE PROCEEDING:

- ENSURE UNIT IS SQUARE.
- THE BELOW DIMENSIONS ARE CRITICAL TO THE FINAL ROOF ASSEMBLY.
- MEASUREMENTS SHOULD BE HELD WITHIN +/- 1/4" [6mm].
- MEASUREMENTS OUTSIDE OF TOLERANCE WILL LEAD TO INABILITY TO ASSEMBLY THE ROOF.

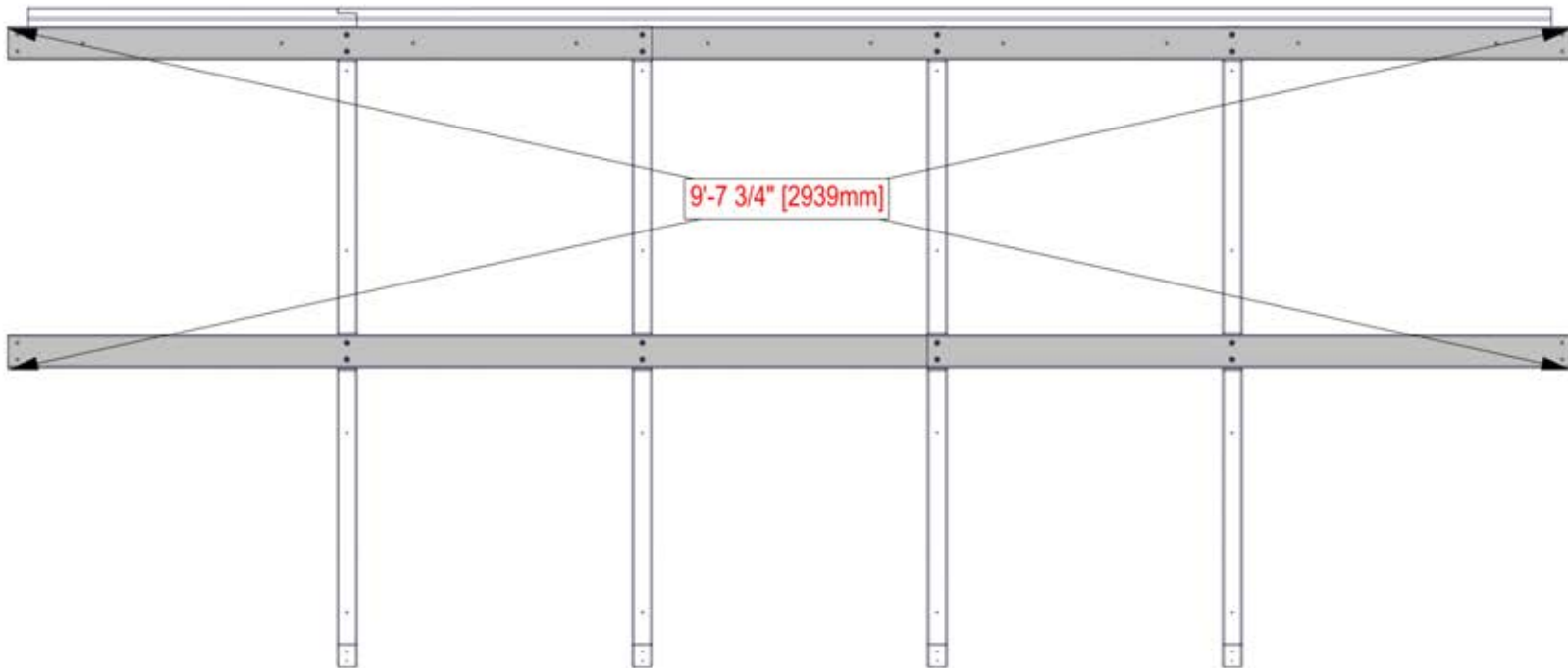

**LOOSEN HARDWARE TO ADJUST FOR SQUARING IF NEEDED.**

# STEP 89 - ROOF ASSEMBLY

QTY	PART NUMBER	DESCRIPTION
16	H101203	SCREW PWH 8x15x1 1/4 BLK

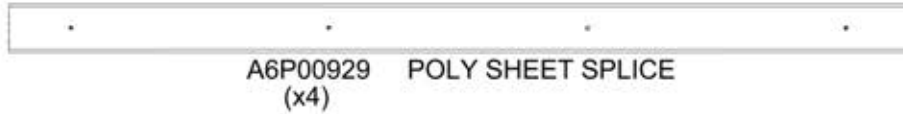

- ALIGN HOLES IN POLY SHEET SPLICES WITH PILOT HOLES IN RAFTERS.
- **DO NOT OVERTIGHTEN.**
- SET ASSEMBLY TO THE SIDE.

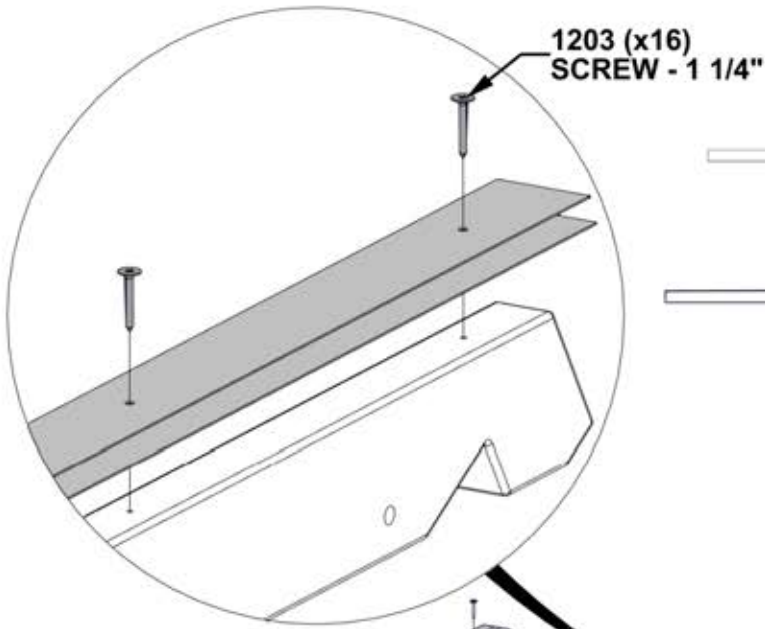

**ENSURE THE NARROWER SIDE  
OF POLY SPLICE FACES UP.**

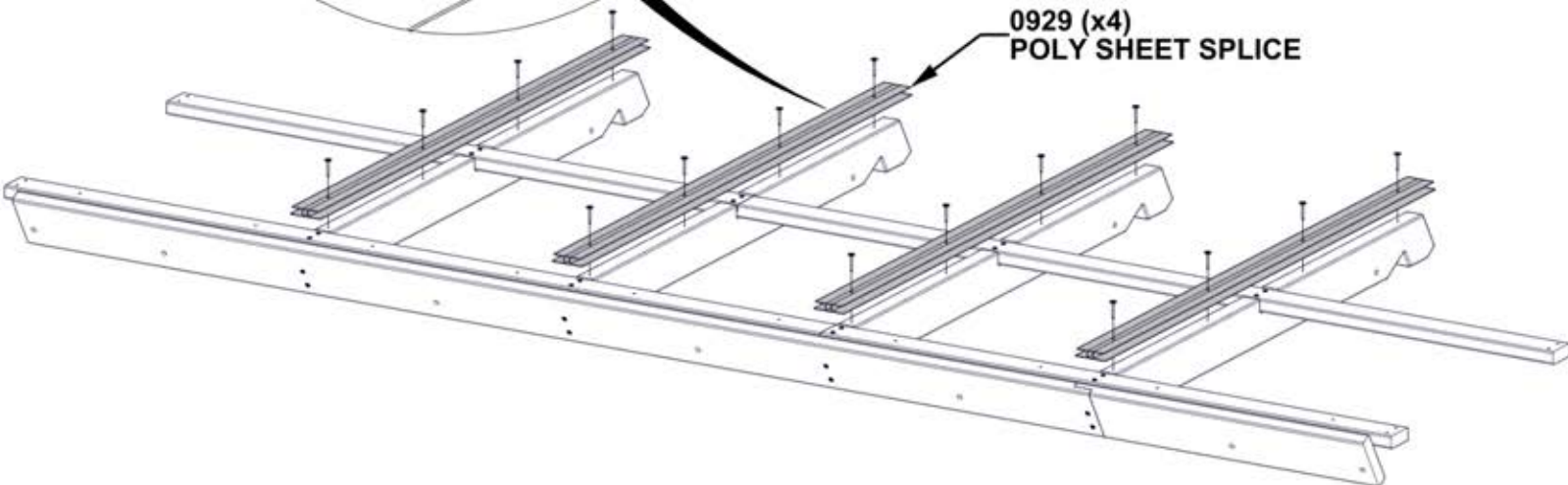
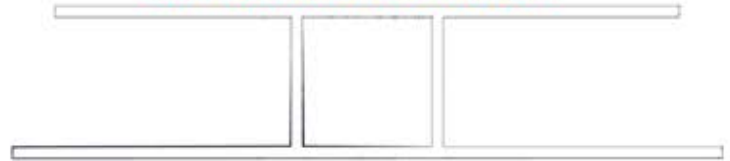

**REPEAT STEPS 86 THROUGH 89  
FOR 2ND ROOF ASSEMBLY**

# STEP 90 - ROOF ASSEMBLY



ROOF ASSEMBLY (x2) - FROM PREVIOUS STEPS

- TWO ADULTS REQUIRED FOR THIS STEP.
- PURLINS REST IN NOTCHES IN GABLE AS SHOWN.
- RIDGE RESTS IN BRACKETS AS SHOWN.
- REPEAT THIS STEP FOR OTHER SIDE WITH SECOND ROOF ASSEMBLY.

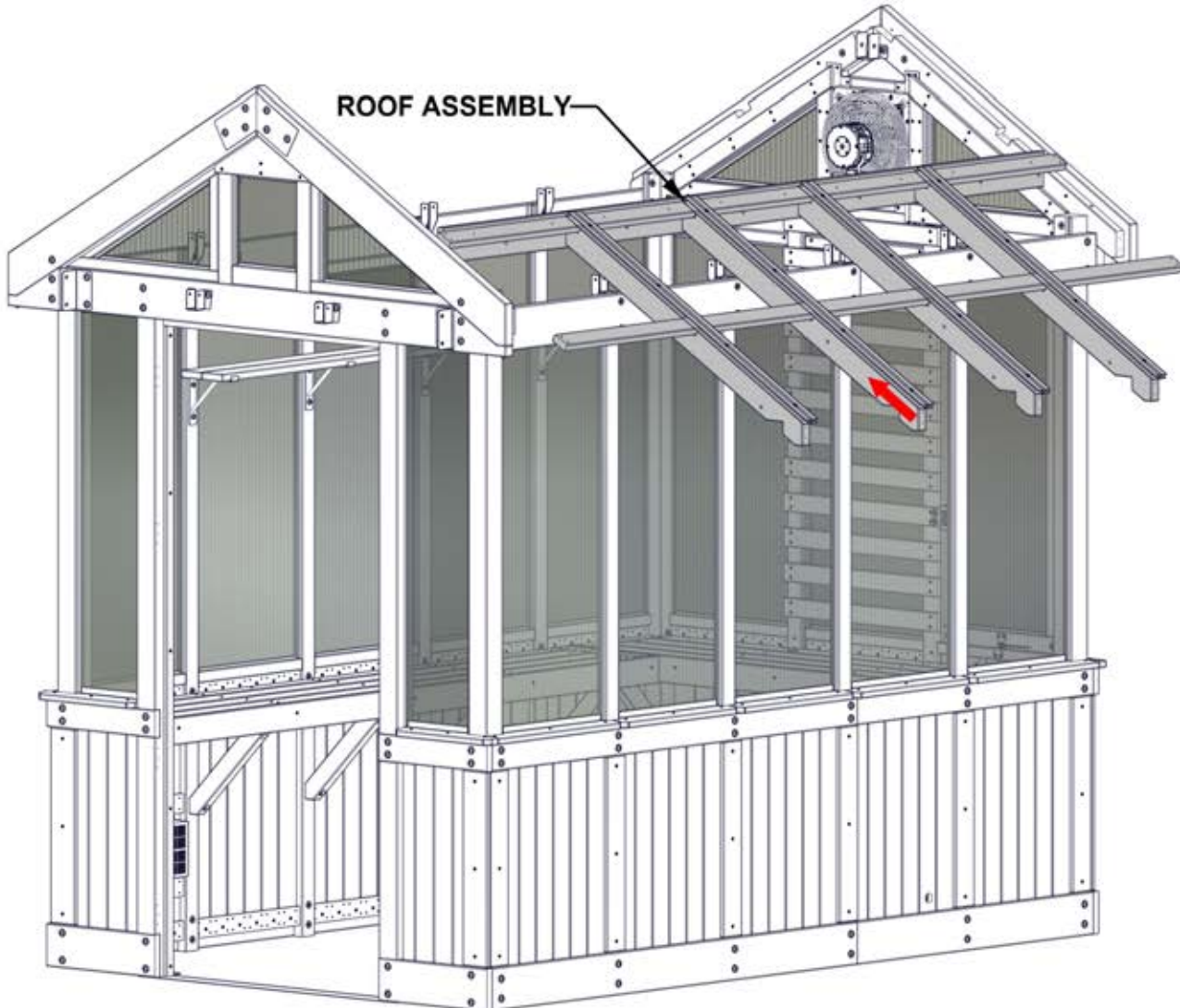
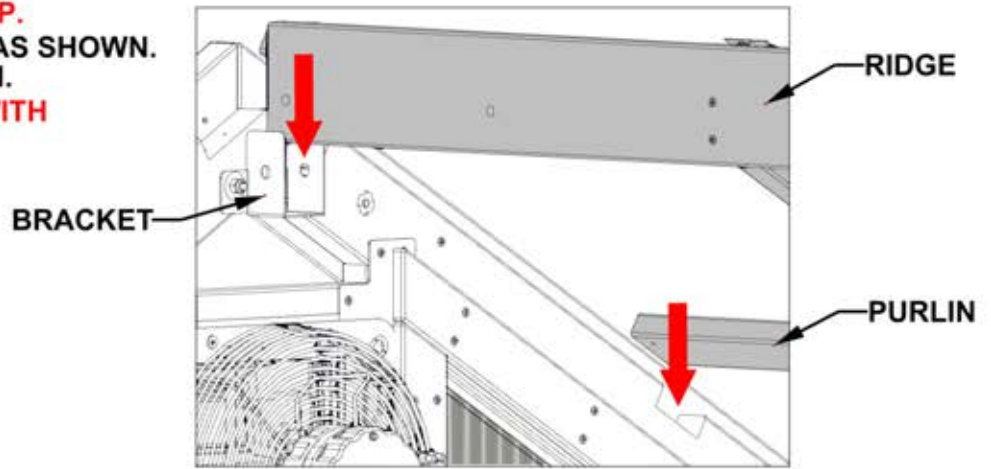

# STEP 91 - ROOF ASSEMBLY

QTY	PART NUMBER	DESCRIPTION
2	H100195	BOLT WH 5/16x2 3/4 BLK
5	H100198	WASHER LOCK EXT 8x19
5	H100378	BOLT WH 5/16x1 3/4 BLK
5	H100379	T-NUT 5/16 BLK
2	H100478	WASHER FLAT 8x27 BLK
2	H100479	NUT LOCK 5/16 BLK

**INSERT T-NUTS FIRST.**

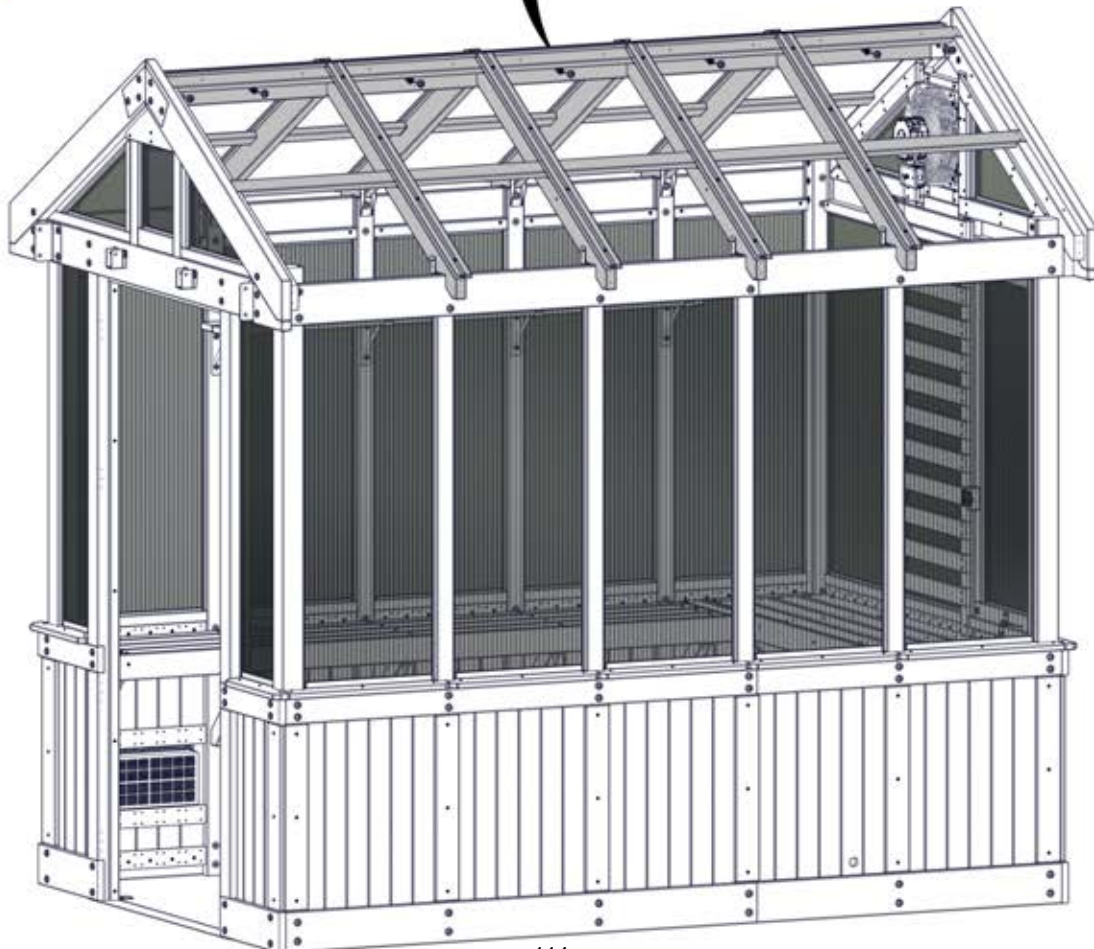
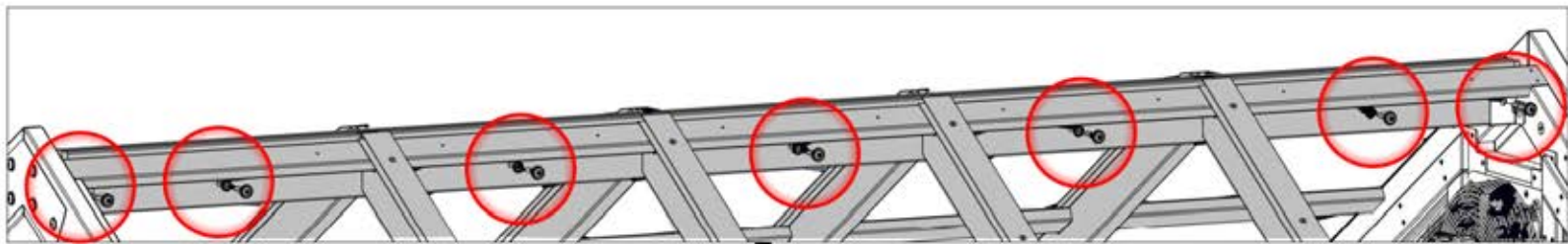
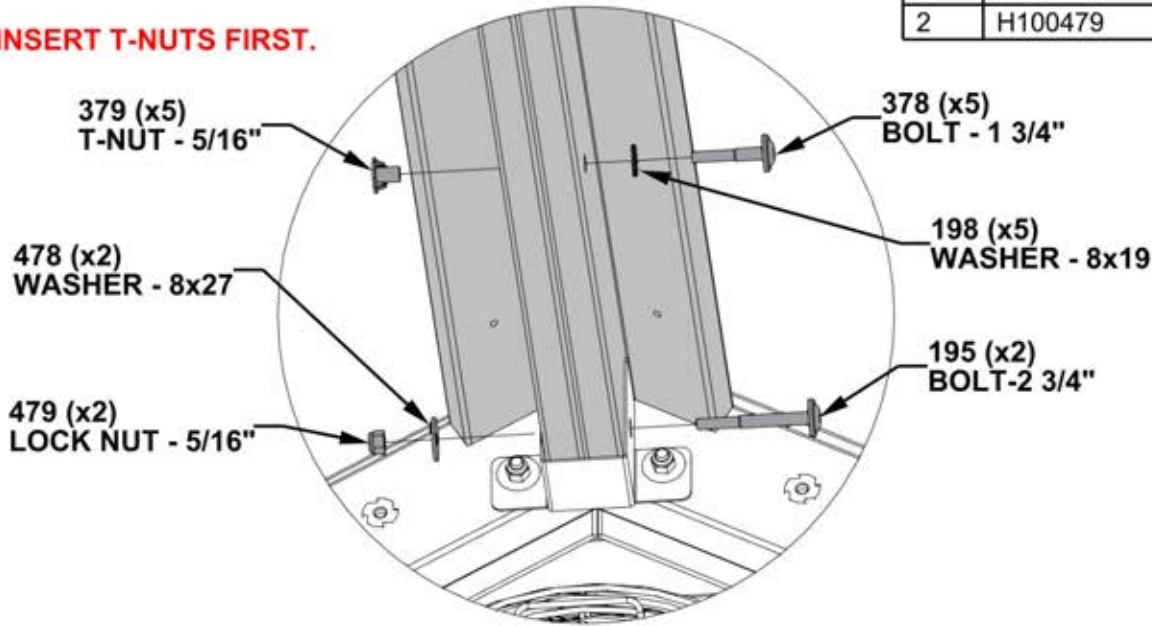

# STEP 92 - ROOF ASSEMBLY

QTY	PART NUMBER	DESCRIPTION
8	H100488	BOLT WH 1/4x2 BLK
8	H100630	WASHER FLAT 8x19 BLK
8	H100653	NUT LOCK 1/4 BLK

ATTACH HARDWARE TO ALL 8 RAFTERS.

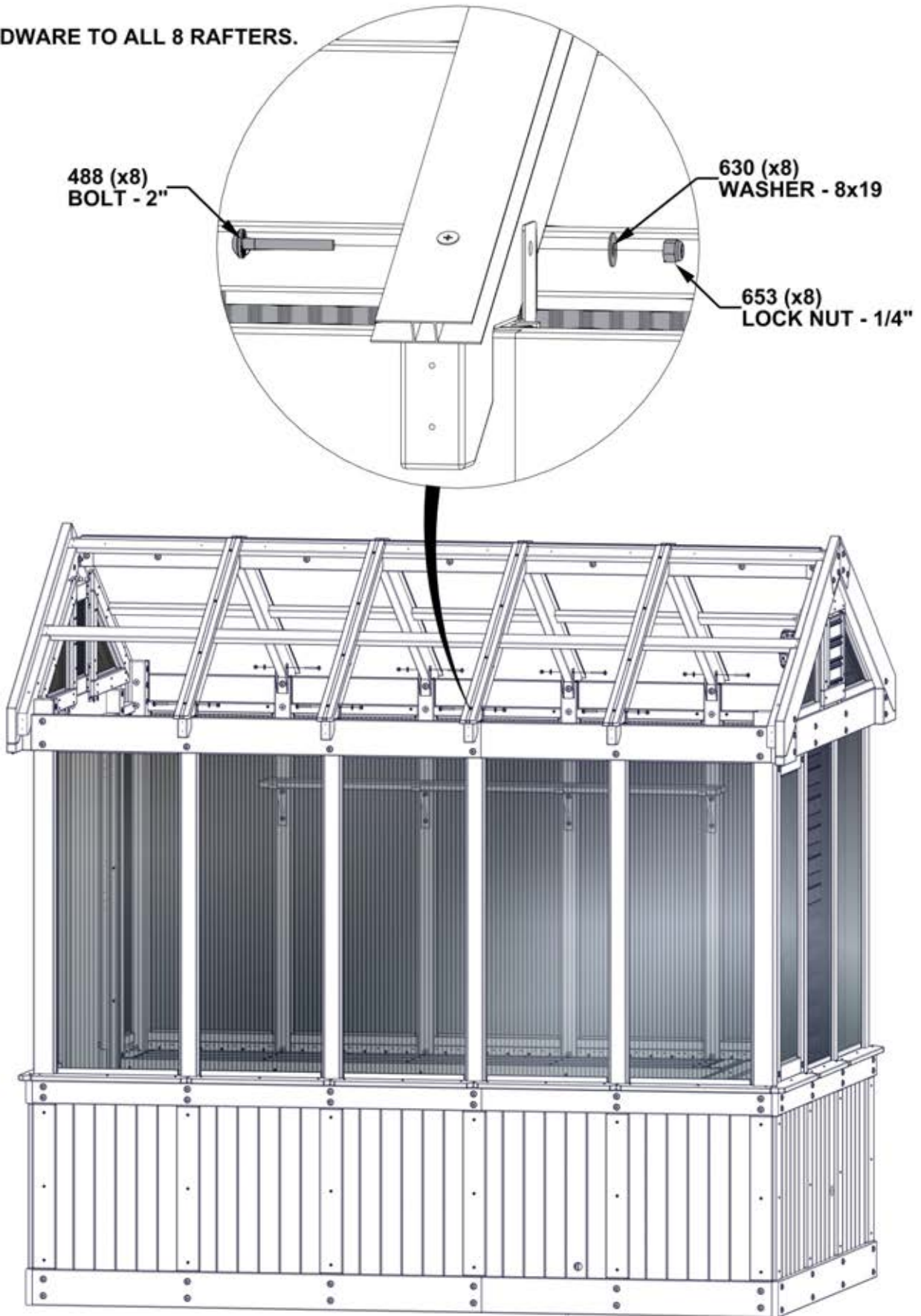

# STEP 93 - ROOF ASSEMBLY

QTY	PART NUMBER	DESCRIPTION
16	H100391	SCREW PFH 8x2 BLK

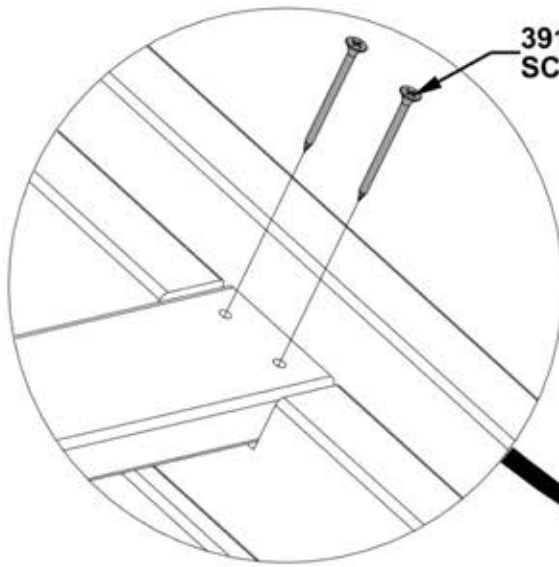

391 (x16)  
SCREW - 2"

INSERT SCREWS IN PILOT HOLES AT  
THE ENDS OF ALL PURLINS AS SHOWN.

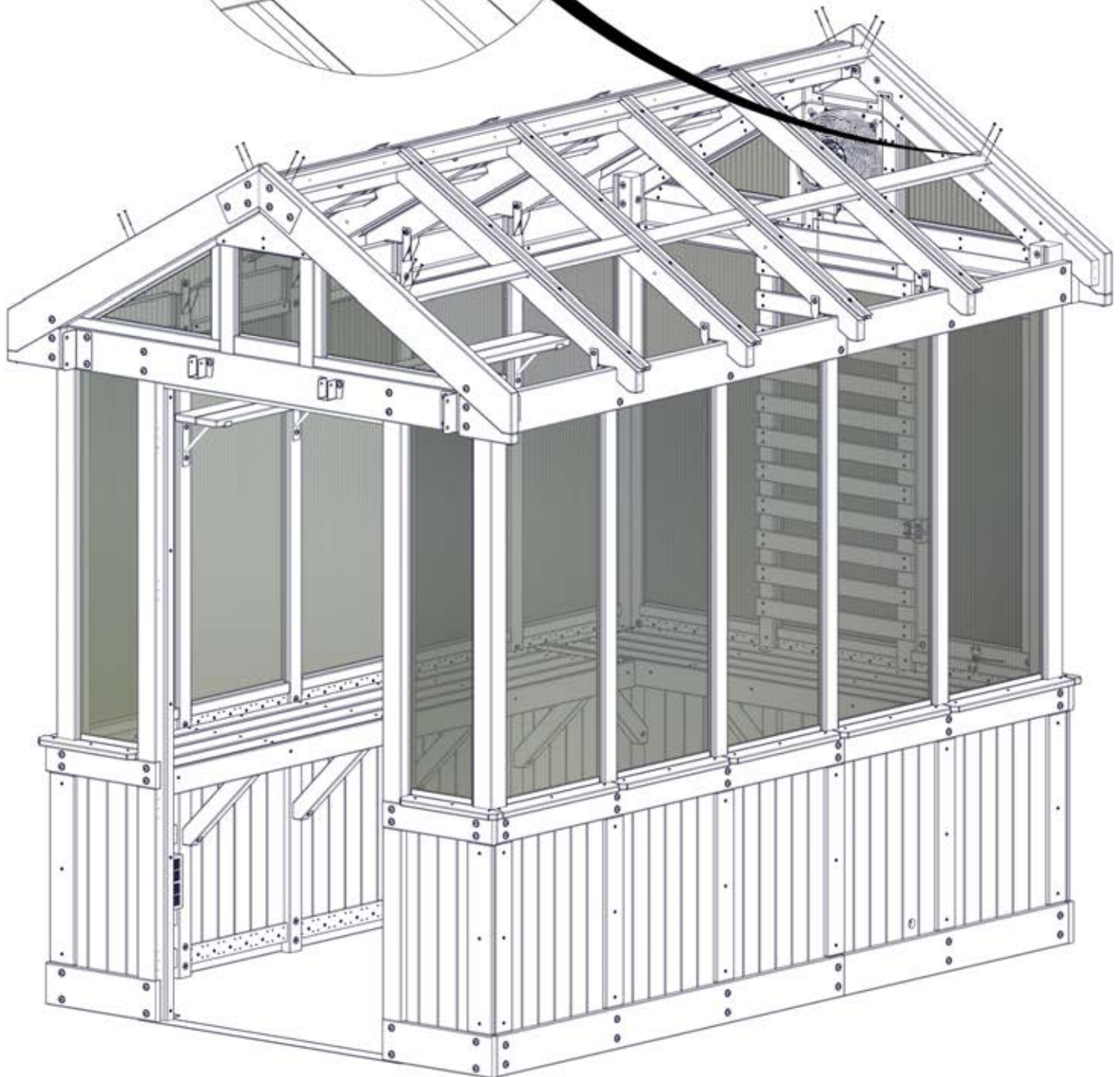

# STEP 94 - ROOF ASSEMBLY

QTY	PART NUMBER	DESCRIPTION
6	H100395	SCREW PFH 8x3/4 BLK

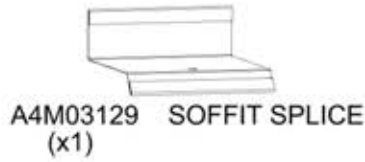
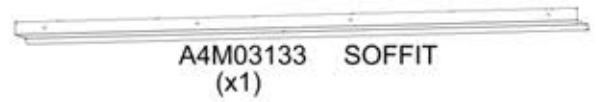
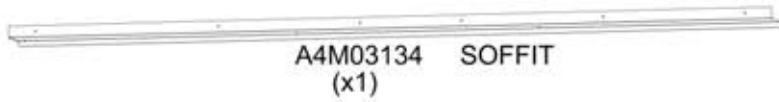

**WARNING: GLOVES ARE RECOMMENDED WHEN HANDLING STEEL.**

- REMOVE BLUE FILM FROM SOFFIT AND SOFFIT SPLICE.
- 90 DEGREE BEND ON SOFFIT BUTTS UP AGAINST HEADER AS SHOWN.
- SLIDE SOFFIT INTO SOFFIT SPLICE AS SHOWN.
- ENDS OF SOFFIT SHOULD BE FLUSH WITH GABLE END.
- ATTACH WITH SCREWS AS SHOWN.

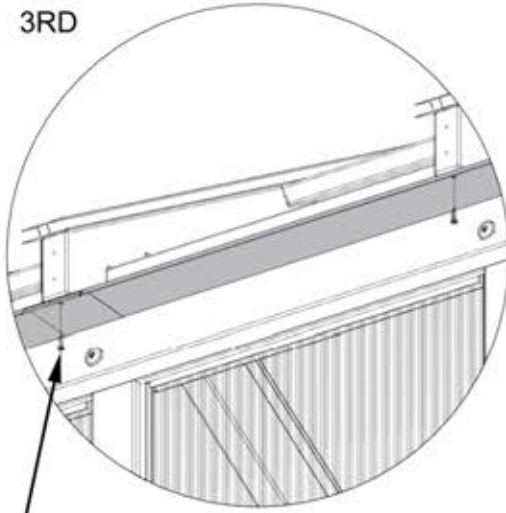
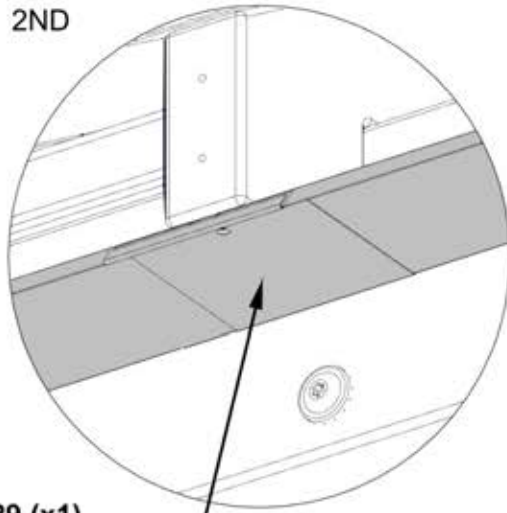
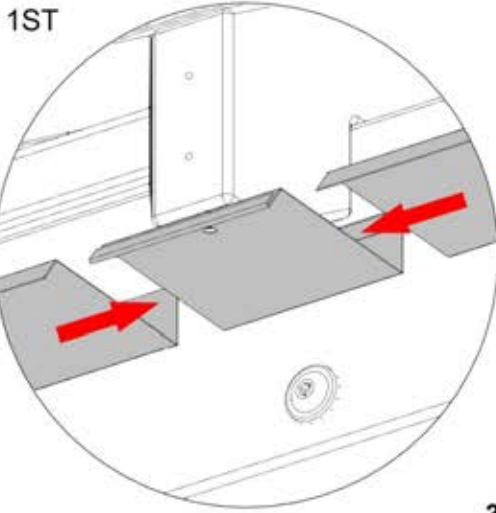

3129 (x1)  
SOFFIT SPLICE

395 (x6)  
SCREW - 3/4"

3134 (x1)  
SOFFIT

3133 (x1)  
SOFFIT

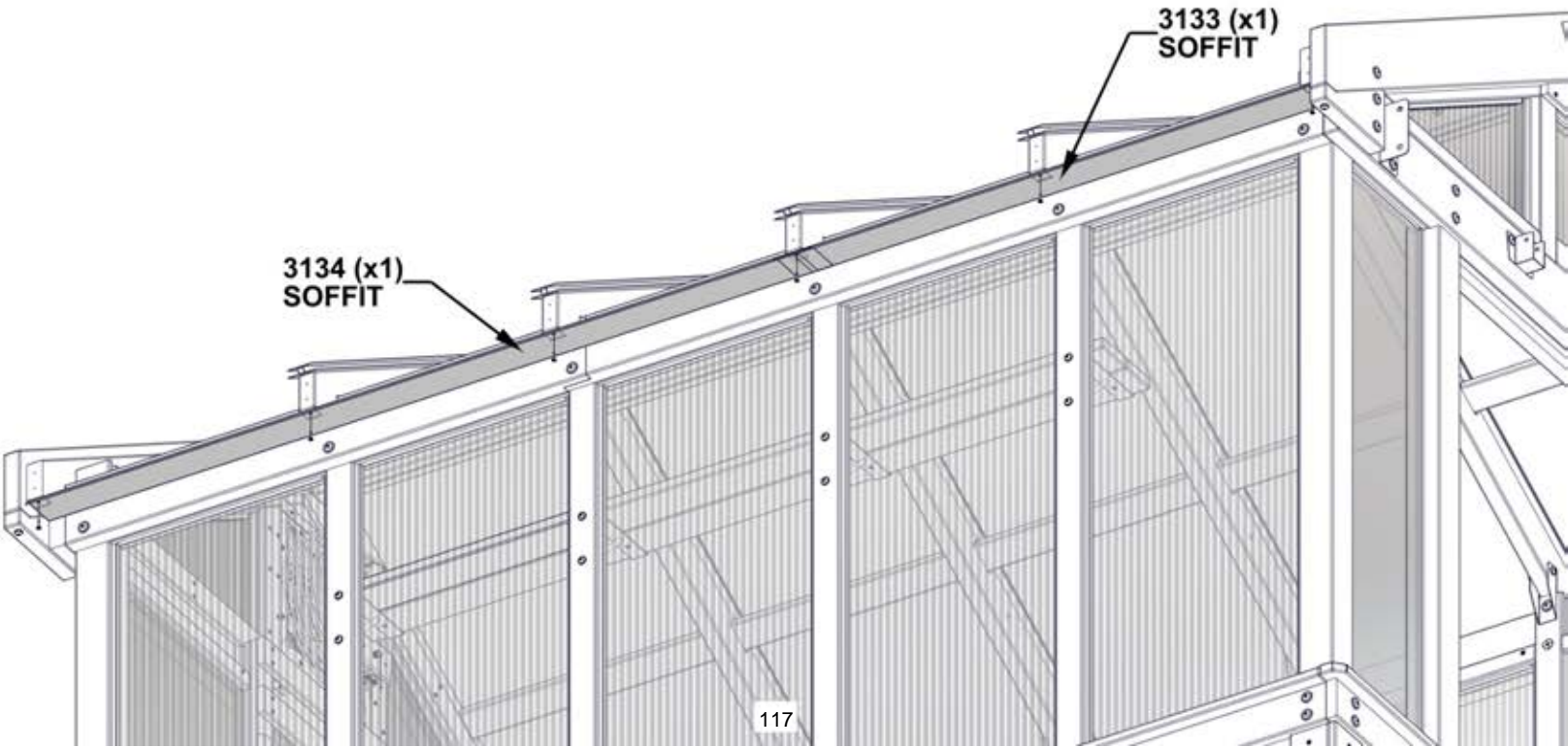

# STEP 95 - ROOF ASSEMBLY

QTY	PART NUMBER	DESCRIPTION
10	H100395	SCREW PFH 8x3/4 BLK

ATTACH SOFFIT WITH SCREWS USING THROUGH HOLES IN SOFFIT AS SHOWN.

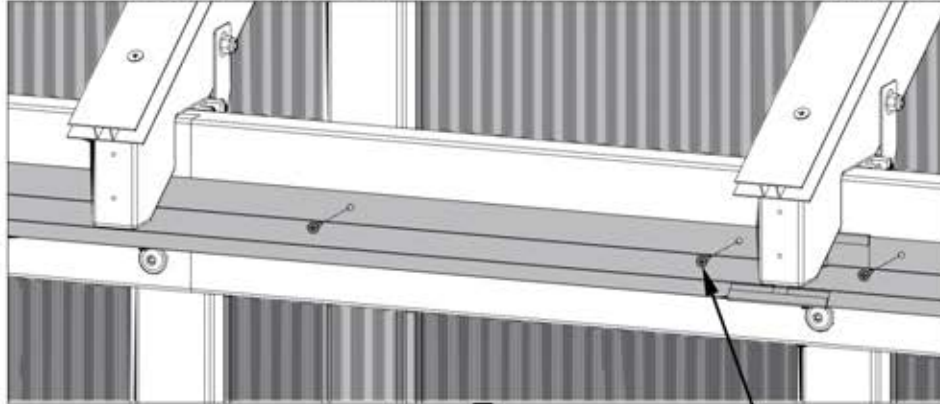

395 (x10)  
SCREW - 3/4"

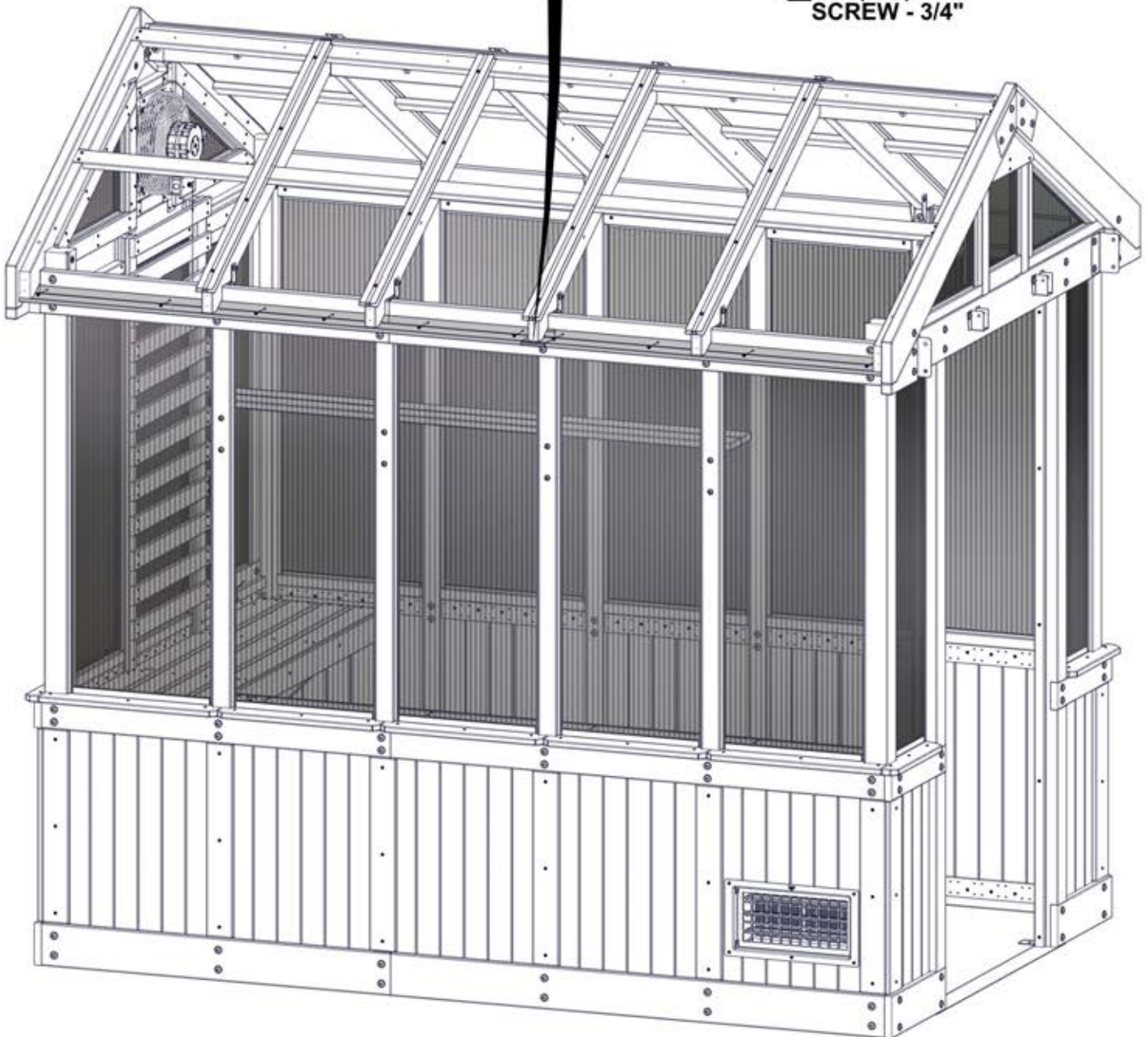

# STEP 96 - ROOF ASSEMBLY

QTY	PART NUMBER	DESCRIPTION
12	H100391	SCREW PFH 8x2 BLK



Q03 FASCIA - W4L20109  
(x1) 15/16"x4 7/16"x47 1/16" (24x112x1196)



Q04 FASCIA - W4L20110  
(x1) 15/16"x4 7/16"x68 7/16" (24x112x1738)

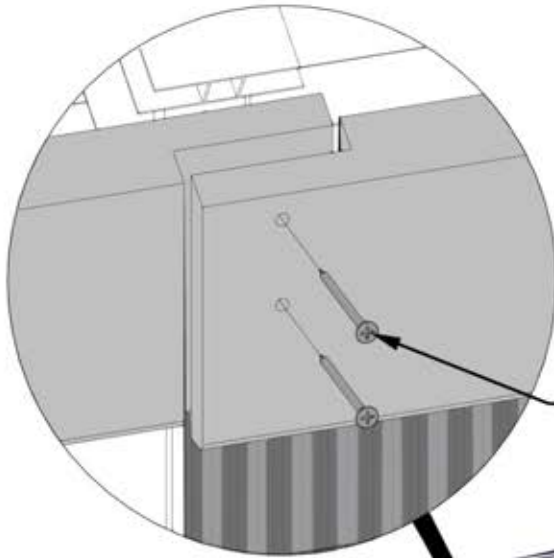

ALIGN FASCIA BOARDS WITH PILOT HOLES  
IN RAFTERS AND ATTACH AS SHOWN.

391 (x12)  
SCREW - 2"

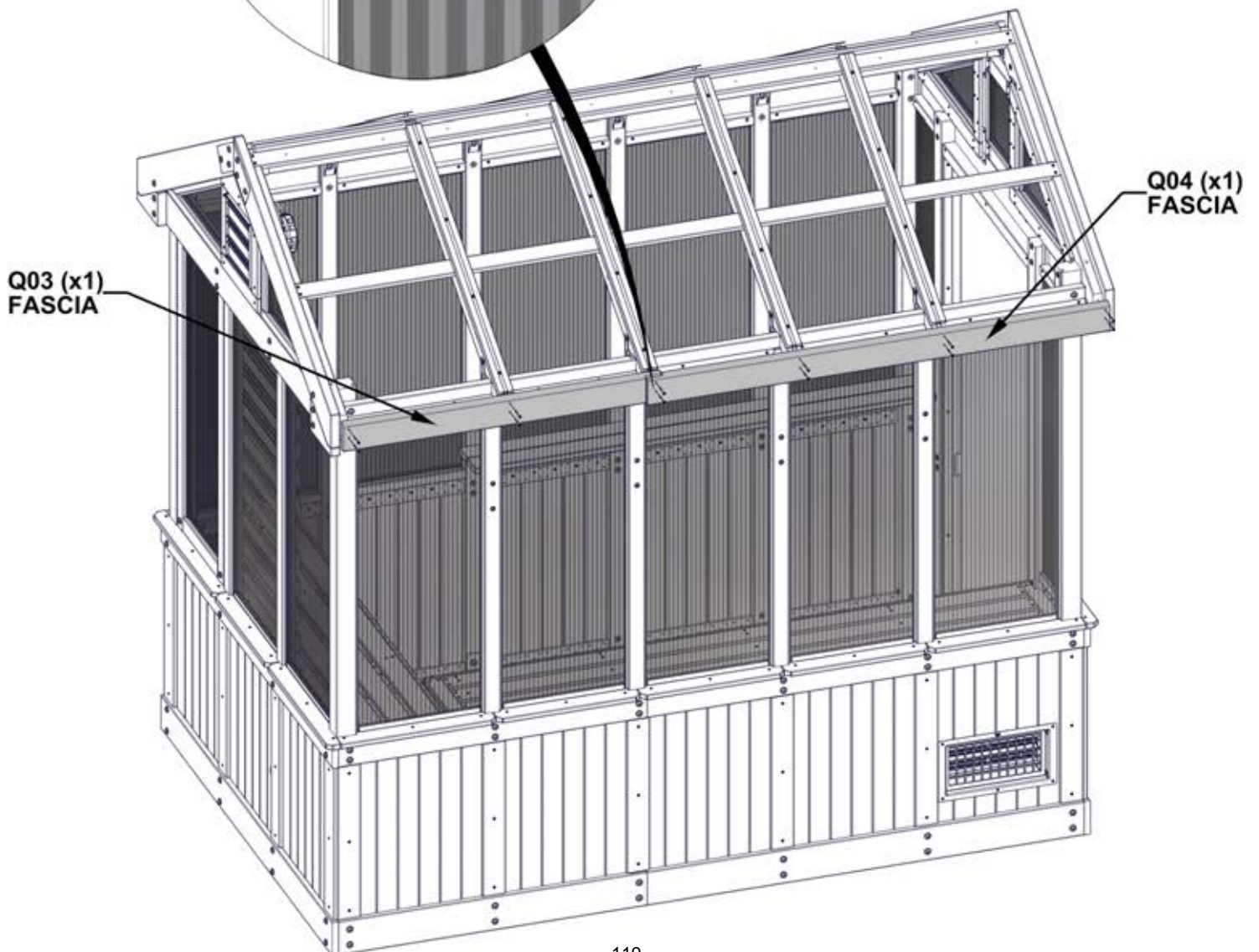

# STEP 97 - ROOF ASSEMBLY

QTY	PART NUMBER	DESCRIPTION
6	H100395	SCREW PFH 8x3/4 BLK

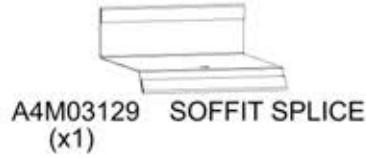
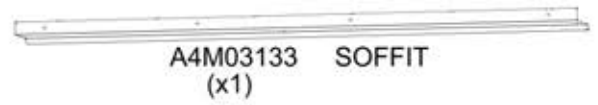
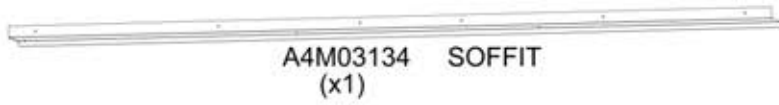

**WARNING: GLOVES ARE RECOMMENDED WHEN HANDLING STEEL.**

- REMOVE BLUE FILM FROM SOFFIT AND SOFFIT SPLICE.
- 90 DEGREE BEND ON SOFFIT BUTTS UP AGAINST HEADER AS SHOWN.
- SLIDE SOFFIT INTO SOFFIT SPLICE AS SHOWN.
- ENDS OF SOFFIT SHOULD BE FLUSH WITH GABLE END.
- ATTACH WITH SCREWS AS SHOWN.

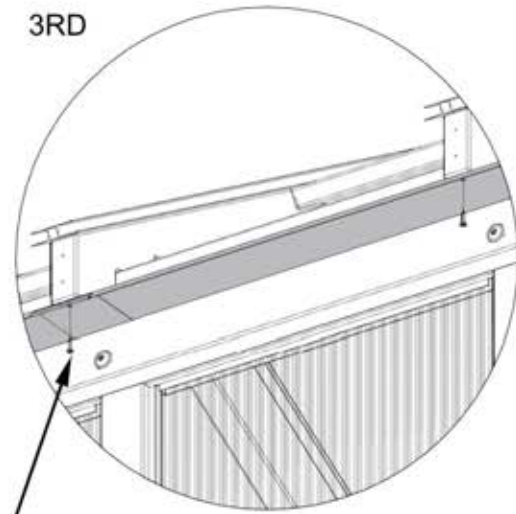
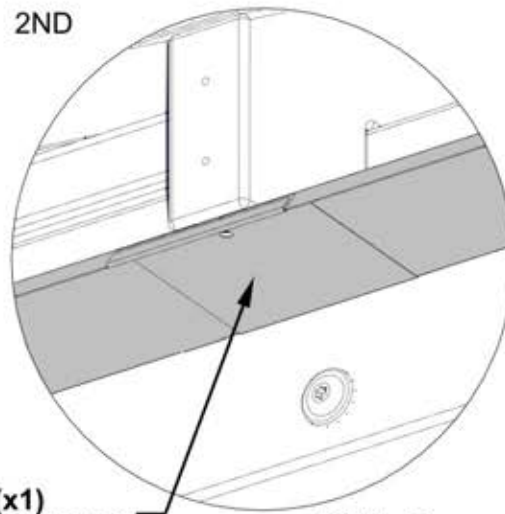
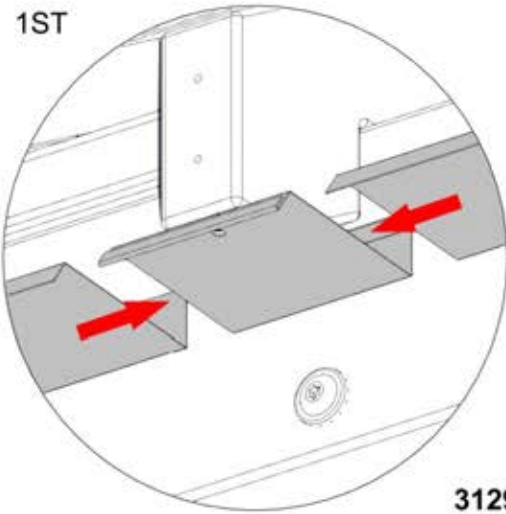

3129 (x1)  
SOFFIT SPLICE

395 (x6)  
SCREW - 3/4"

3134 (x1)  
SOFFIT

3133 (x1)  
SOFFIT

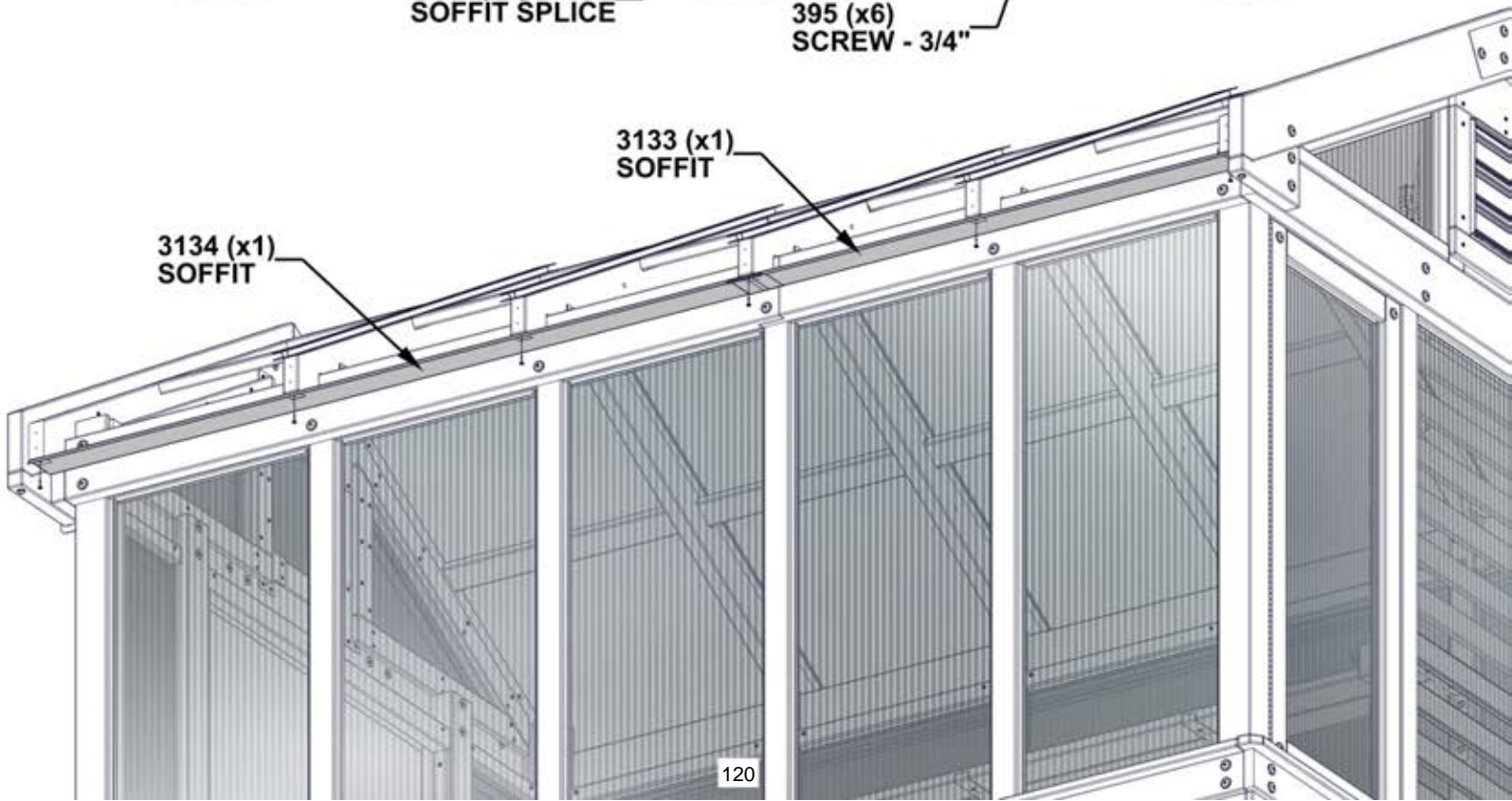

# STEP 98 - ROOF ASSEMBLY

QTY	PART NUMBER	DESCRIPTION
10	H100395	SCREW PFH 8x3/4 BLK

ATTACH SOFFIT WITH SCREWS USING THROUGH HOLES IN SOFFIT AS SHOWN.

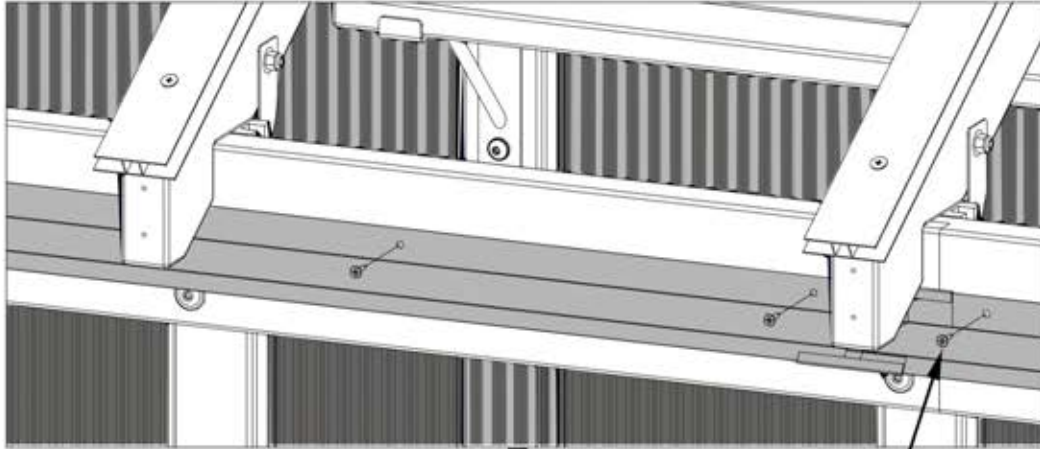

395 (x10)  
SCREW - 3/4"

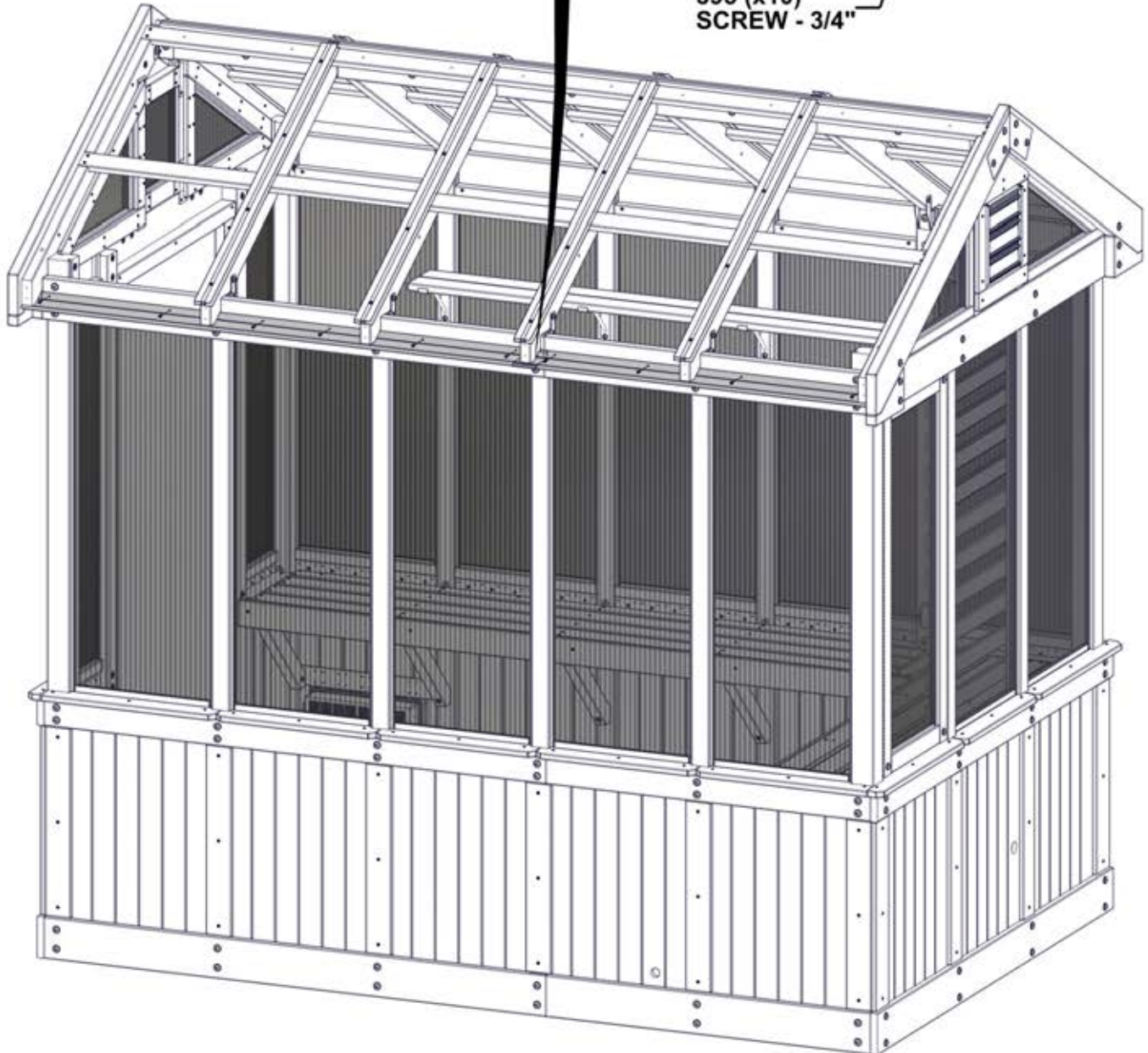

# STEP 99 - ROOF ASSEMBLY

QTY	PART NUMBER	DESCRIPTION
12	H100391	SCREW PFH 8x2 BLK



Q03 FASCIA - W4L20109  
(x1) 15/16"x4 7/16"x47 1/16" (24x112x1196)



Q04 FASCIA - W4L20110  
(x1) 15/16"x4 7/16"x68 7/16" (24x112x1738)

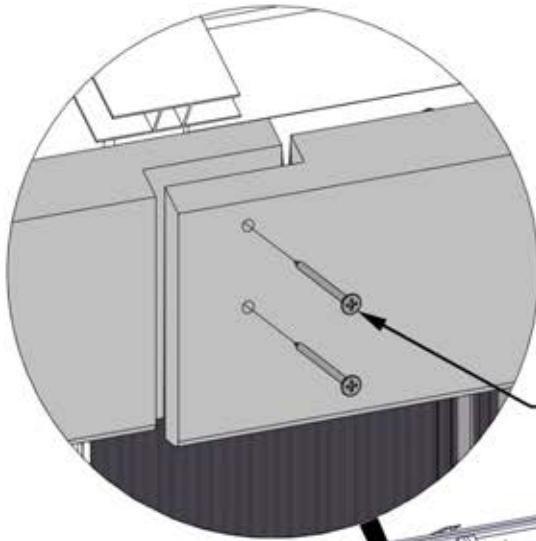

ALIGN FASCIA BOARDS WITH PILOT HOLES IN RAFTERS AND ATTACH AS SHOWN.

391 (x12)  
SCREW - 2"

Q03 (x1)  
FASCIA

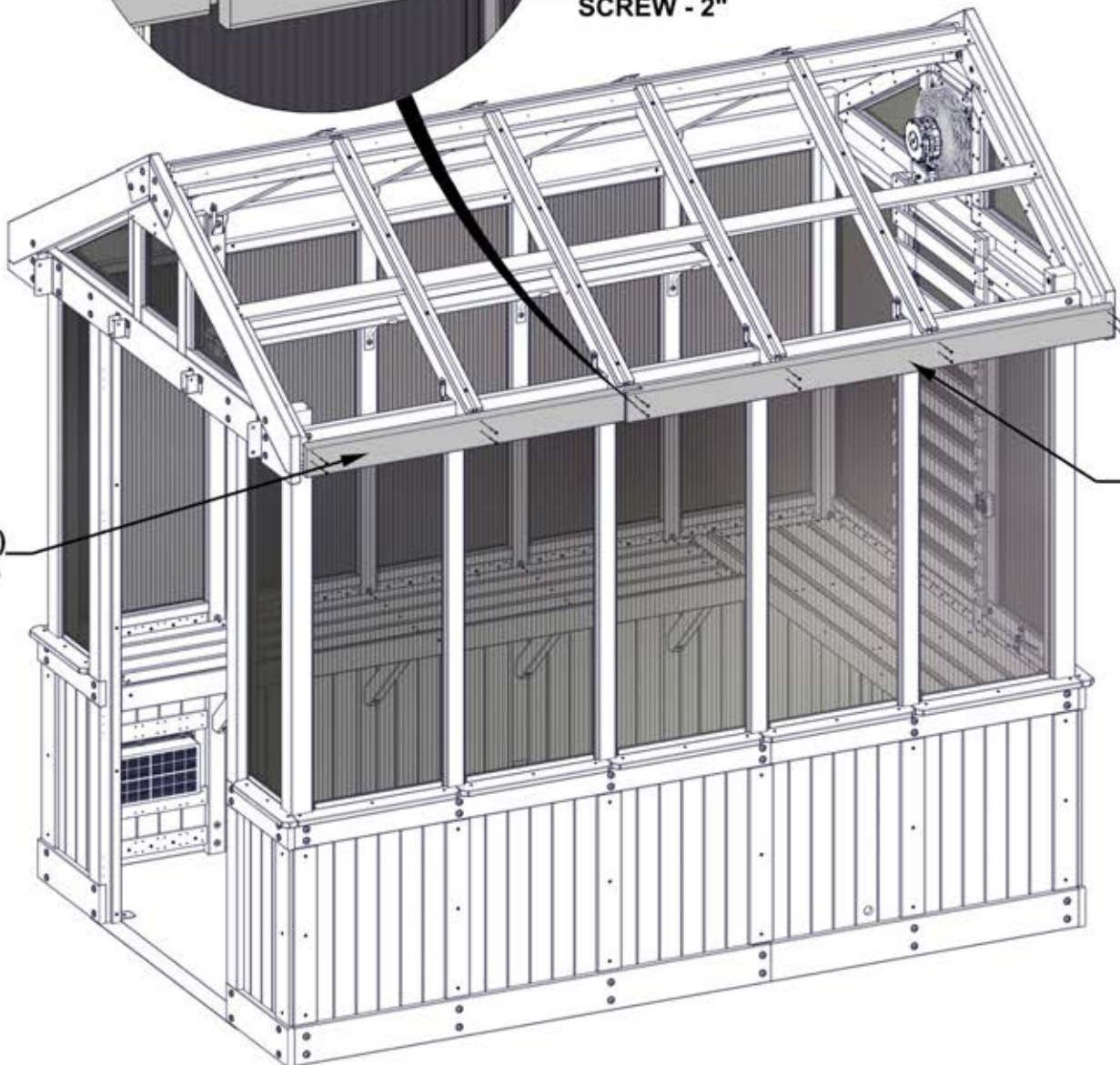

Q04 (x1)  
FASCIA

# STEP 100 - ROOF ASSEMBLY

QTY	PART NUMBER	DESCRIPTION
4	H100195	BOLT WH 5/16x2 3/4 BLK
4	H100198	WASHER LOCK EXT 8x19
4	H100379	TNUT-5/16" BLK



E14 ACCESSORY TRUSS - W4L20111  
(x2) 1 7/16"x3 3/8"x54 1/8" (36x86x1375)

**INSERT T-NUTS FIRST.**

198 (x4)  
WASHER - 8x19

195 (x4)  
BOLT-2 3/4"

**ATTACH JOISTS USING THROUGH HOLES IN MIDDLE TWO SETS OF RAFTERS AS SHOWN.**

379 (x4)  
TNUT-5/16"

E14 (x2)  
JOIST

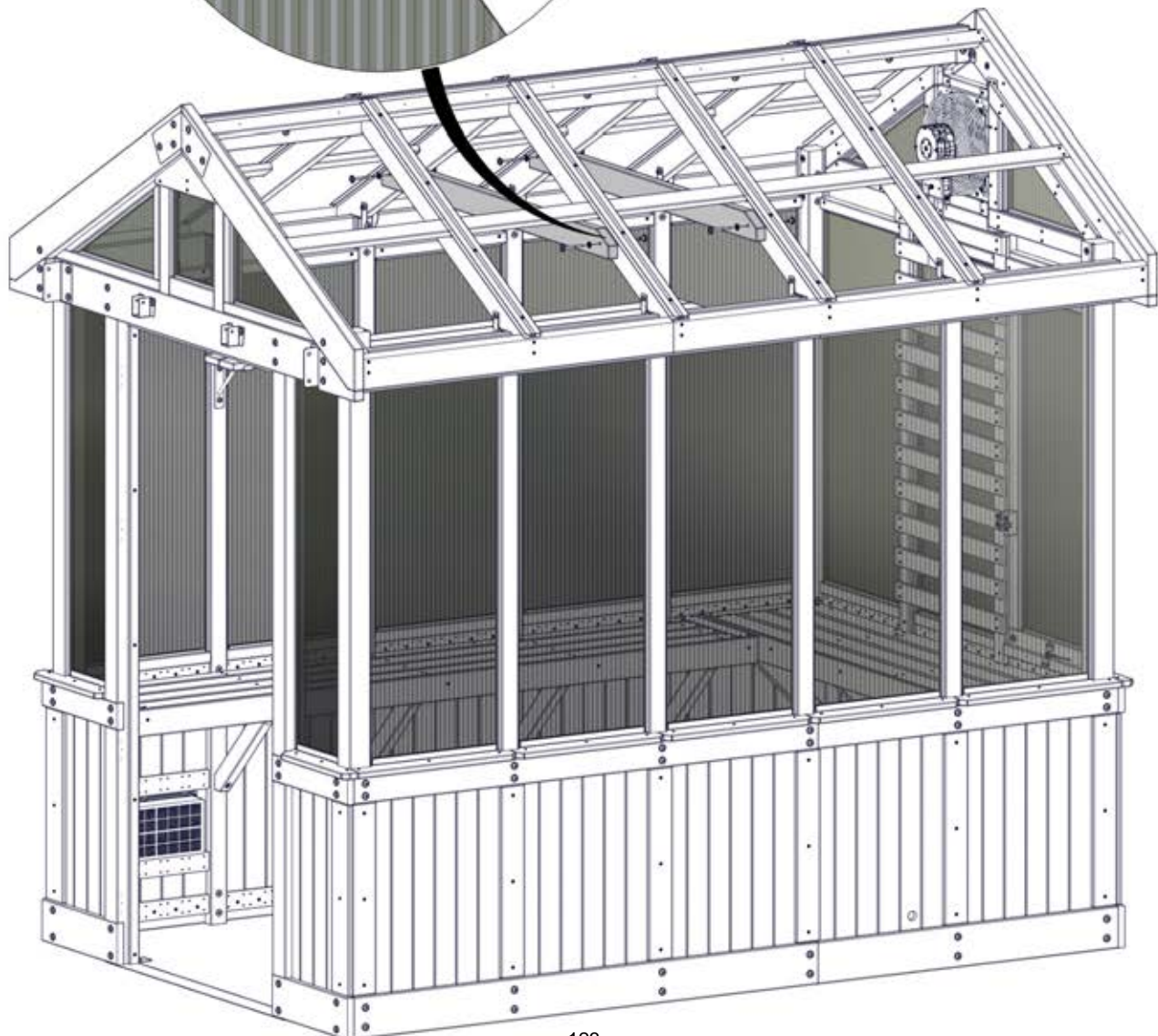

# STEP 101 - ROOF ASSEMBLY

A6P00930 POLY CHANNEL  
(x4)

**REMOVE TAPE LINER ON POLY CHANNELS BEFORE INSTALLING.**

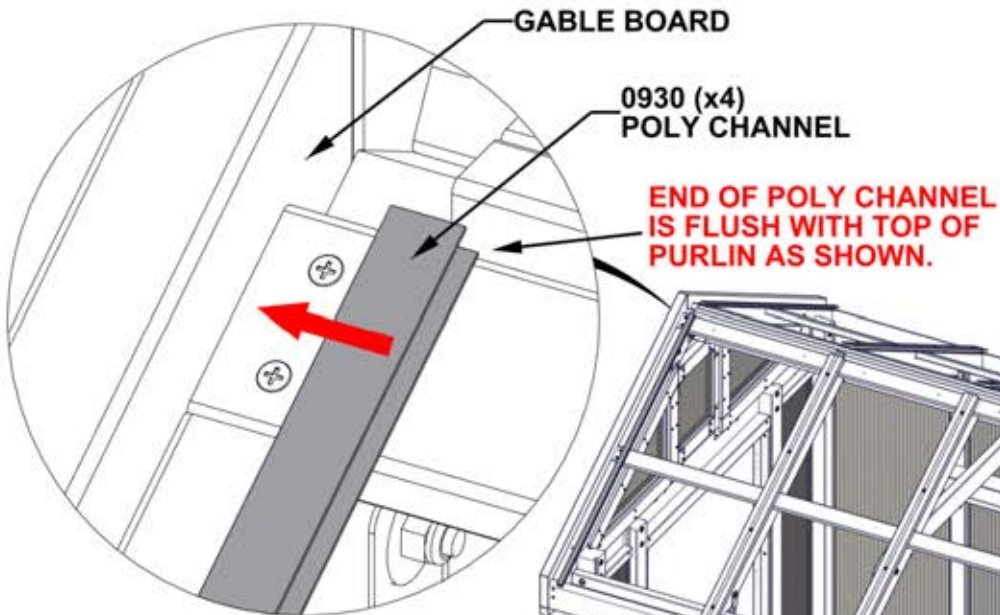
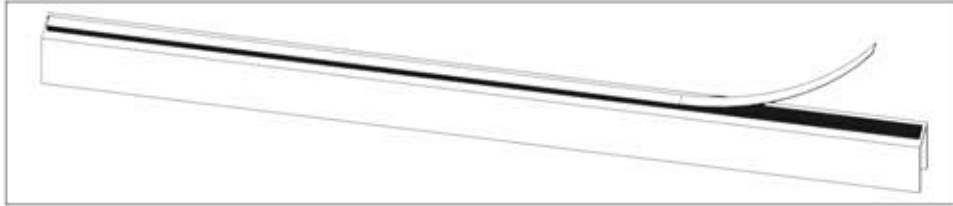

**FIRMLY PRESS POLY CHANNEL AGAINST GABLE BOARD TO ENSURE ADHESION.**

**COMPLETE AT ALL FOUR GABLE BOARDS.**

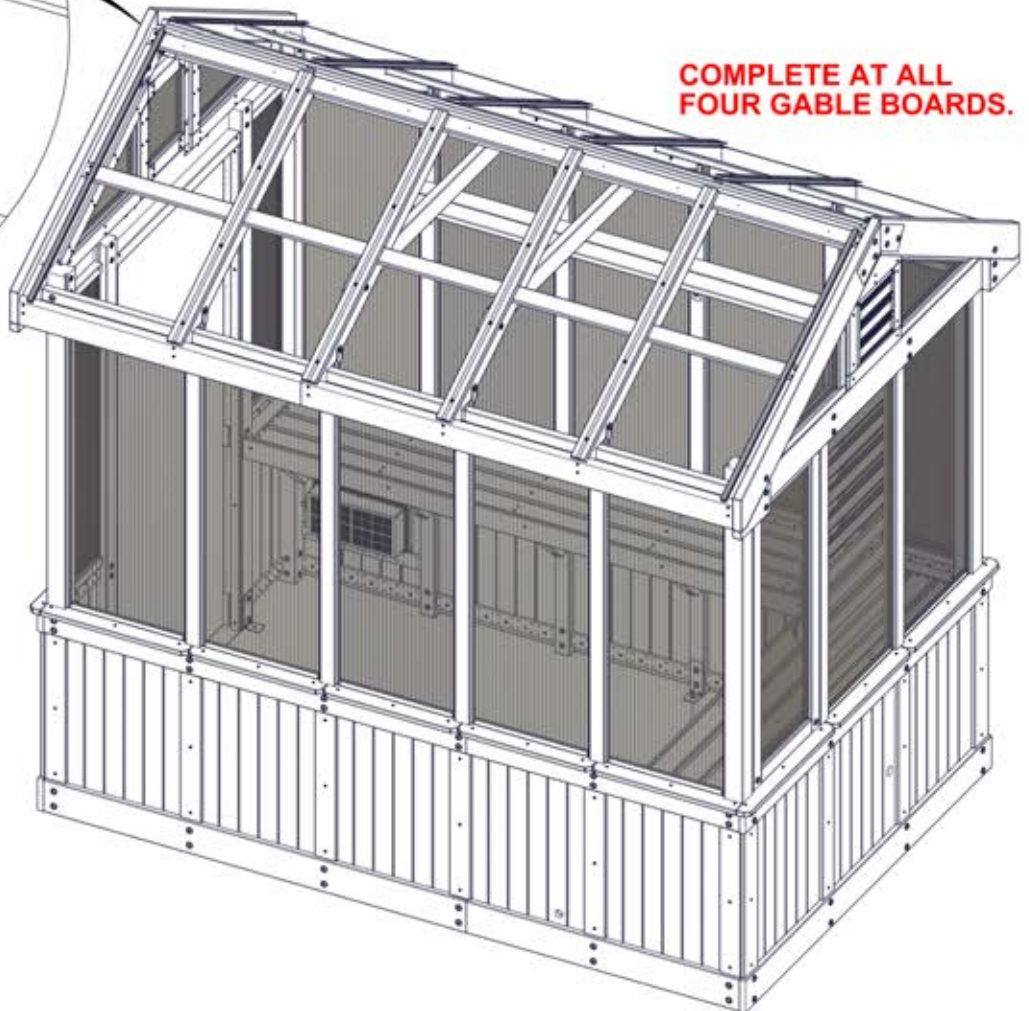

# STEP 102 - ROOF ASSEMBLY



A6P00932 POLY SHEET  
(x6)



A6P00907 POLY CHANNEL  
(x12)



A6P00690 DUST SEAL TAPE

## TO APPLY DUST SEAL TAPE AND POLY CHANNEL:

- CUT 2 STRIPS OF DUST SEAL TAPE THE SAME WIDTH AS THE POLY SHEET.
- WRAP DUST SEAL TAPE ALONG EDGE OF POLY SHEET WIDTH.
- AFTER TAPE IS SECURE, PUSH CHANNEL ON OVER THE TAPE, CENTERING ON THE POLY SHEET.
- REPEAT ON THE BOTTOM SIDE OF POLY SHEET.
- **REPEAT FOR ALL 6 ROOF ASSEMBLIES.**

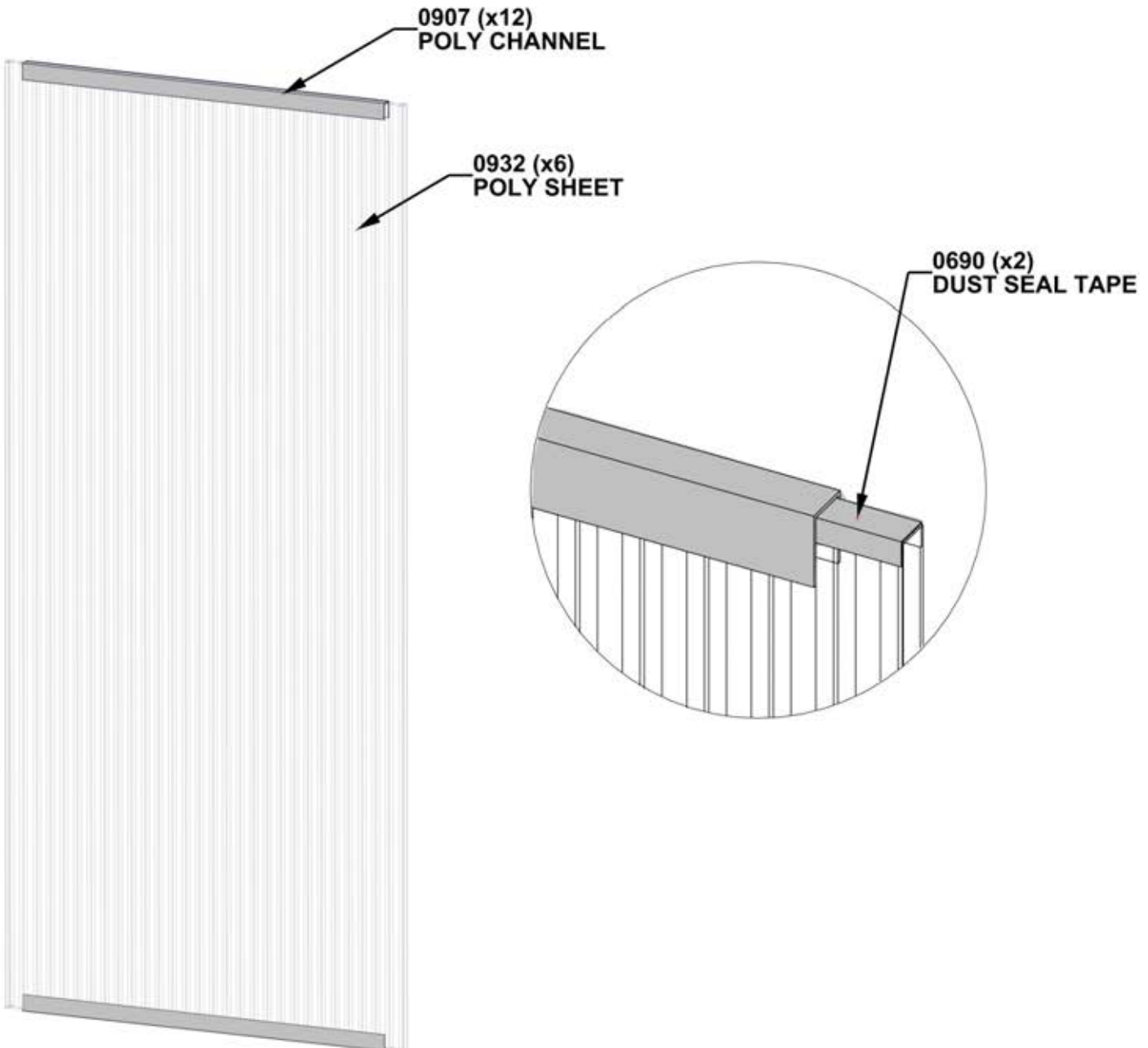

# STEP 103 - ROOF ASSEMBLY

## IMPORTANT!

- ENSURE UV SIDE OF ROOF PANELS ARE FACING OUTSIDE.
- REMOVE THE PROTECTIVE FILM PRIOR TO INSTALLATION OF ROOF PANELS.

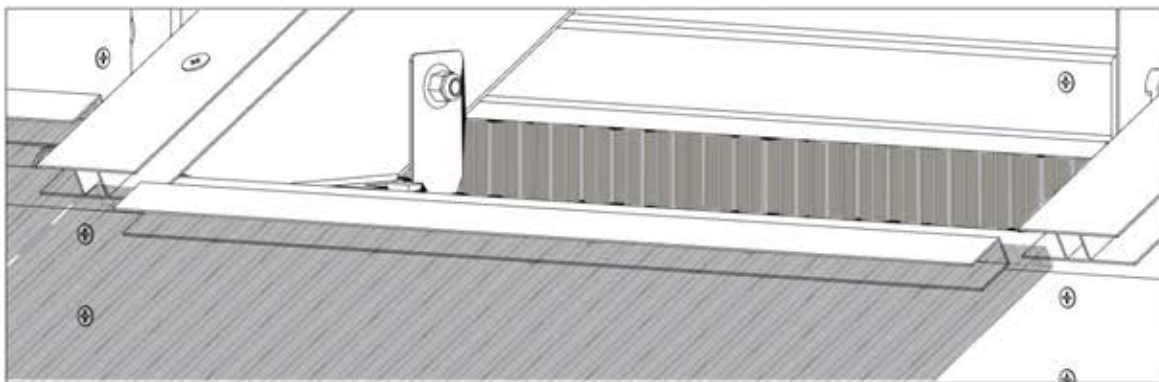

IF NECESSARY, LOOSEN THE SCREWS ON THE POLY SHEET SPLICE.

POLY SHEET SPLICE

- SLIDE POLY SHEETS INTO POLY SHEET SPLICES.
- PUSH THE SHEETS UNTIL BOTTOM OF SHEET IS FLUSH WITH POLY SHEET SPLICE AS SHOWN.

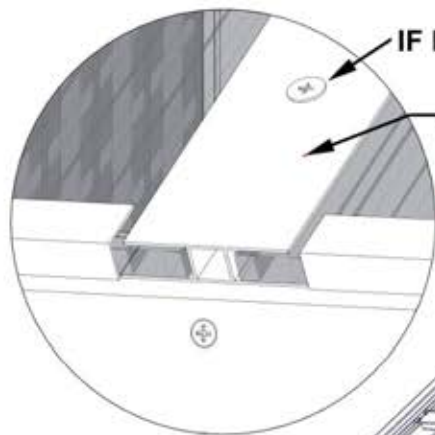

ROOF ASSEMBLIES

ROOF ASSEMBLIES

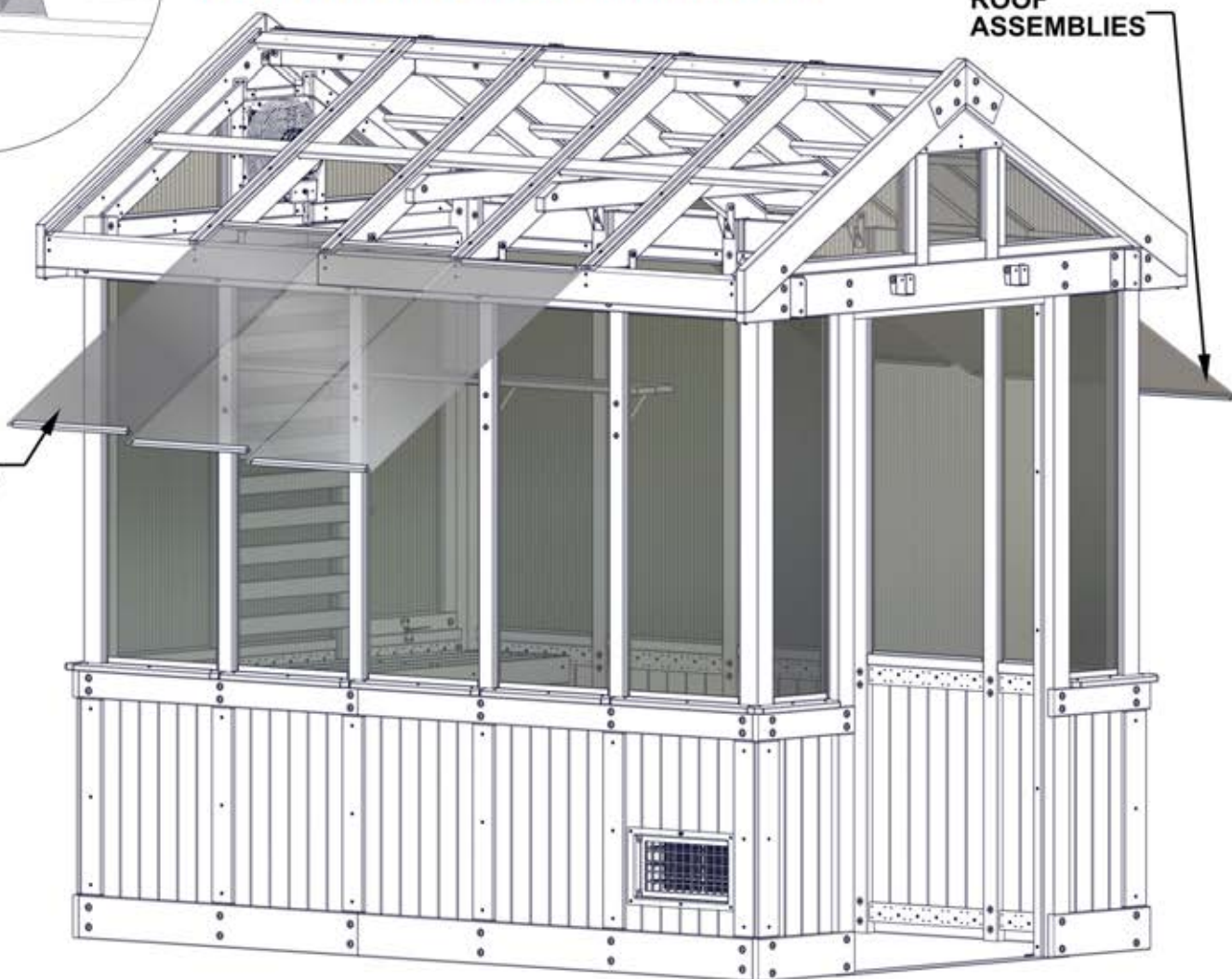

# STEP 104 - ROOF ASSEMBLY



A6P00931 POLY SHEET  
(x4)



A6P00906 POLY CHANNEL  
(x8)



A6P00690 DUST SEAL TAPE

## TO APPLY DUST SEAL TAPE AND POLY CHANNEL:

- CUT 2 STRIPS OF DUST SEAL TAPE THE SAME WIDTH AS THE POLY SHEET.
  - WRAP DUST SEAL TAPE ALONG EDGE OF POLY SHEET WIDTH.
  - AFTER TAPE IS SECURE, PUSH CHANNEL ON OVER THE TAPE, CENTERING ON THE POLY SHEET.
  - REPEAT ON THE BOTTOM SIDE OF POLY SHEET.
- REPEAT FOR ALL 4 ROOF ASSEMBLIES.**

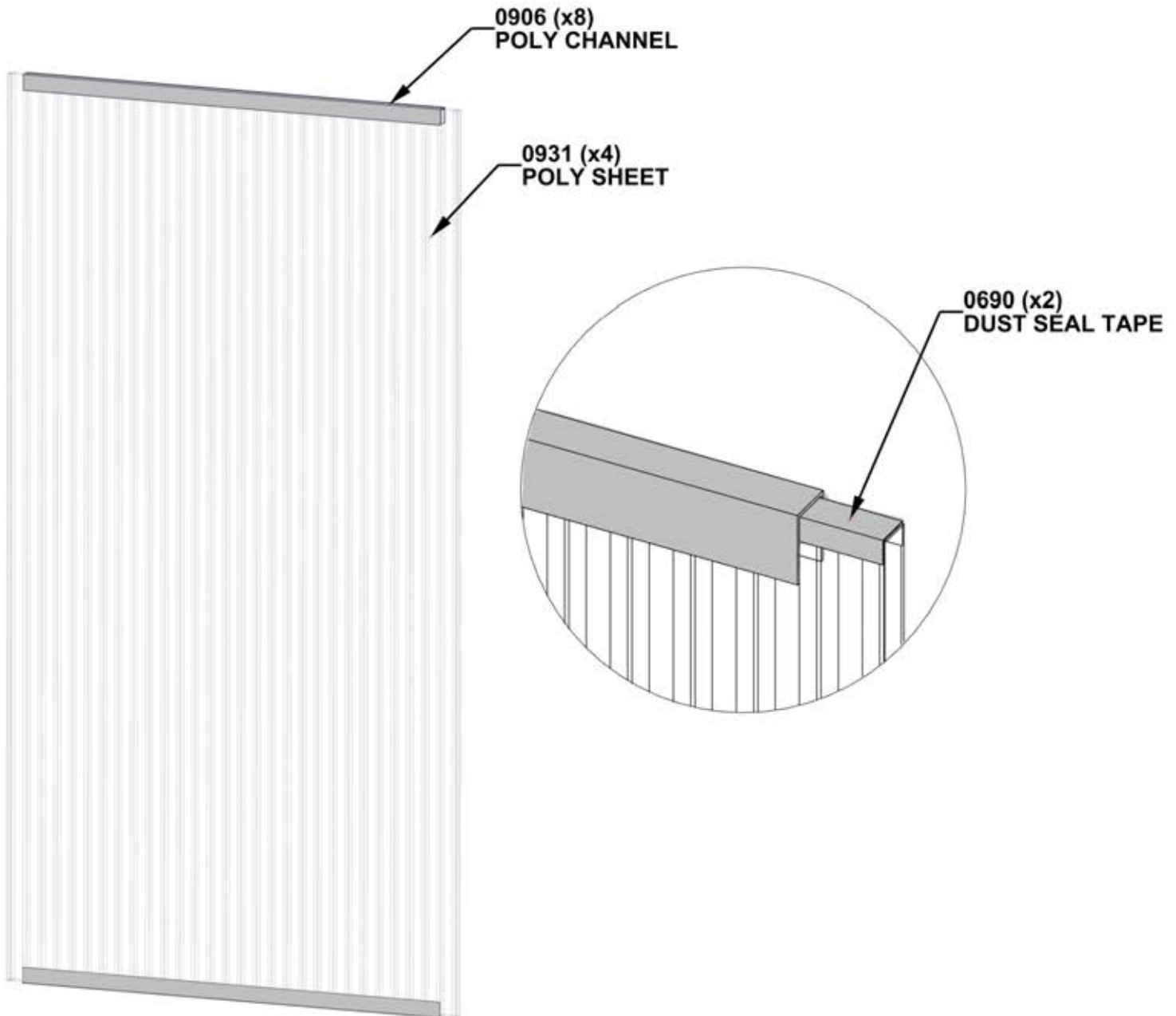

# STEP 105 - ROOF ASSEMBLY

## IMPORTANT!

- ENSURE UV SIDE OF ROOF PANELS ARE FACING OUTSIDE.
- REMOVE THE PROTECTIVE FILM PRIOR TO INSTALLATION OF ROOF PANELS.

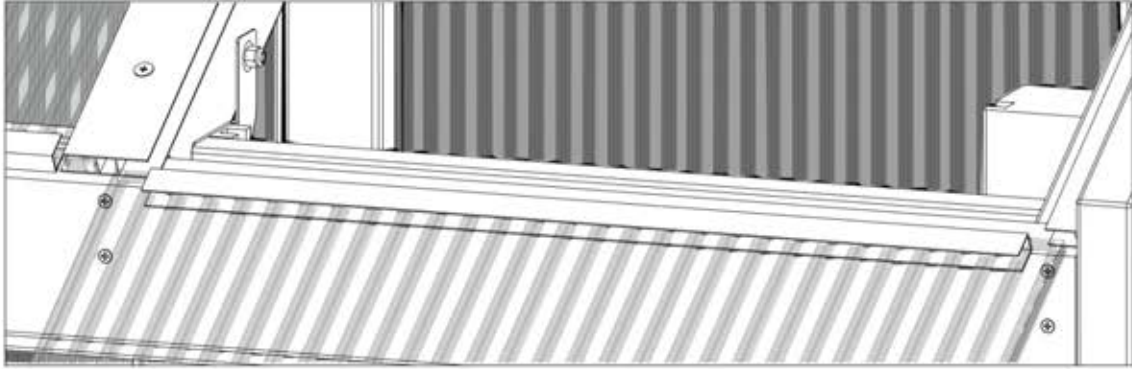

IF NECESSARY, LOOSEN THE SCREWS ON THE POLY SHEET SPLICE.

POLY SHEET SPLICE

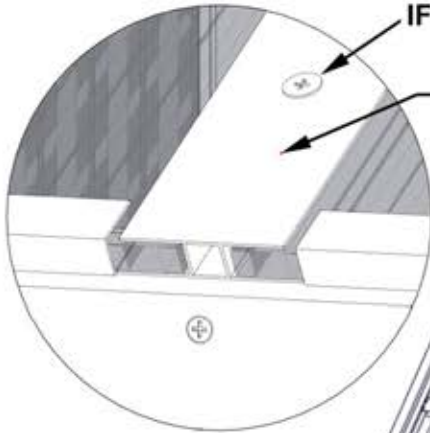

- SLIDE POLY SHEETS INTO POLY SHEET SPLICES.
- PUSH THE SHEETS UNTIL BOTTOM OF SHEET IS FLUSH WITH POLY SHEET SPLICE AS SHOWN.

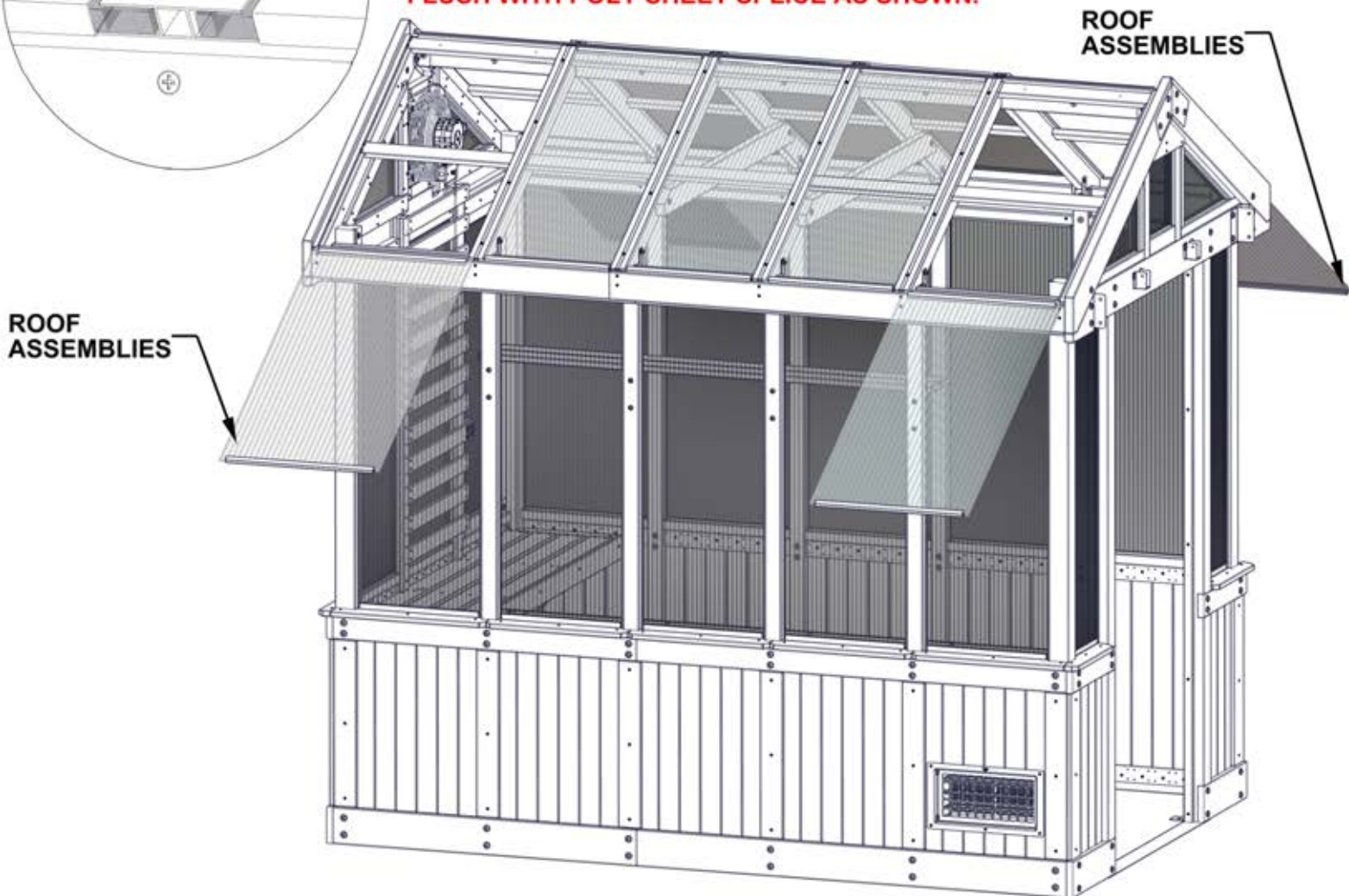

# STEP106 - ROOF ASSEMBLY



A4M03136 SPLICE COVER  
(x8)

**WARNING: GLOVES ARE RECOMMENDED WHEN HANDLING STEEL.**

**REMOVE BLUE FILM FROM SPLICE COVERS.**

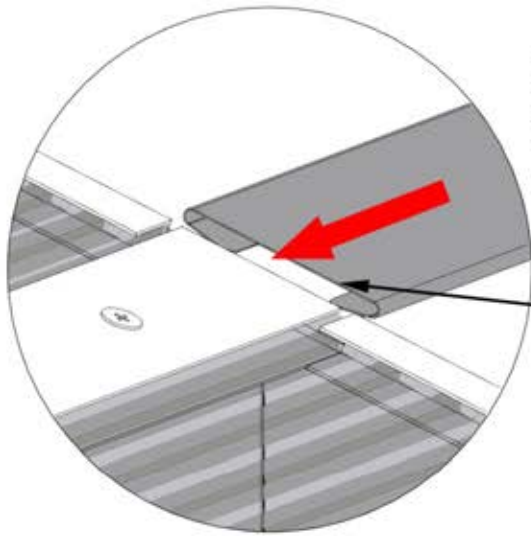

SLIDE TABS ON SPLICE COVERS  
OVER THE TABS ON THE POLY  
CHANNEL AND SLIDE UP UNTIL THE  
BOTTOM OF THE SPLICE IS FLUSH  
WITH BOTTOM OF THE CHANNEL.

**FLAT EDGE  
SLIDES ON FIRST.**

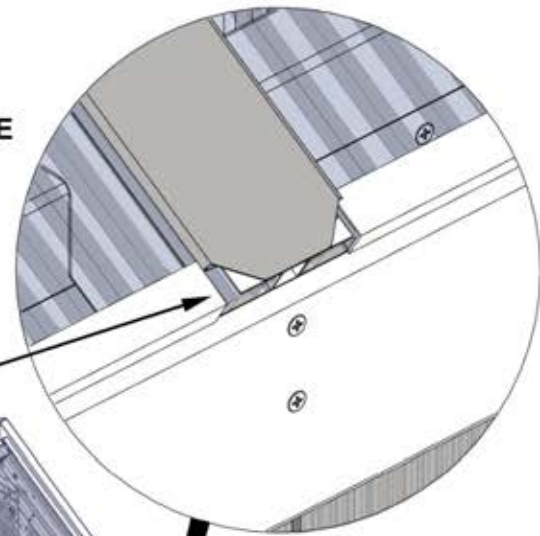

**FLUSH**

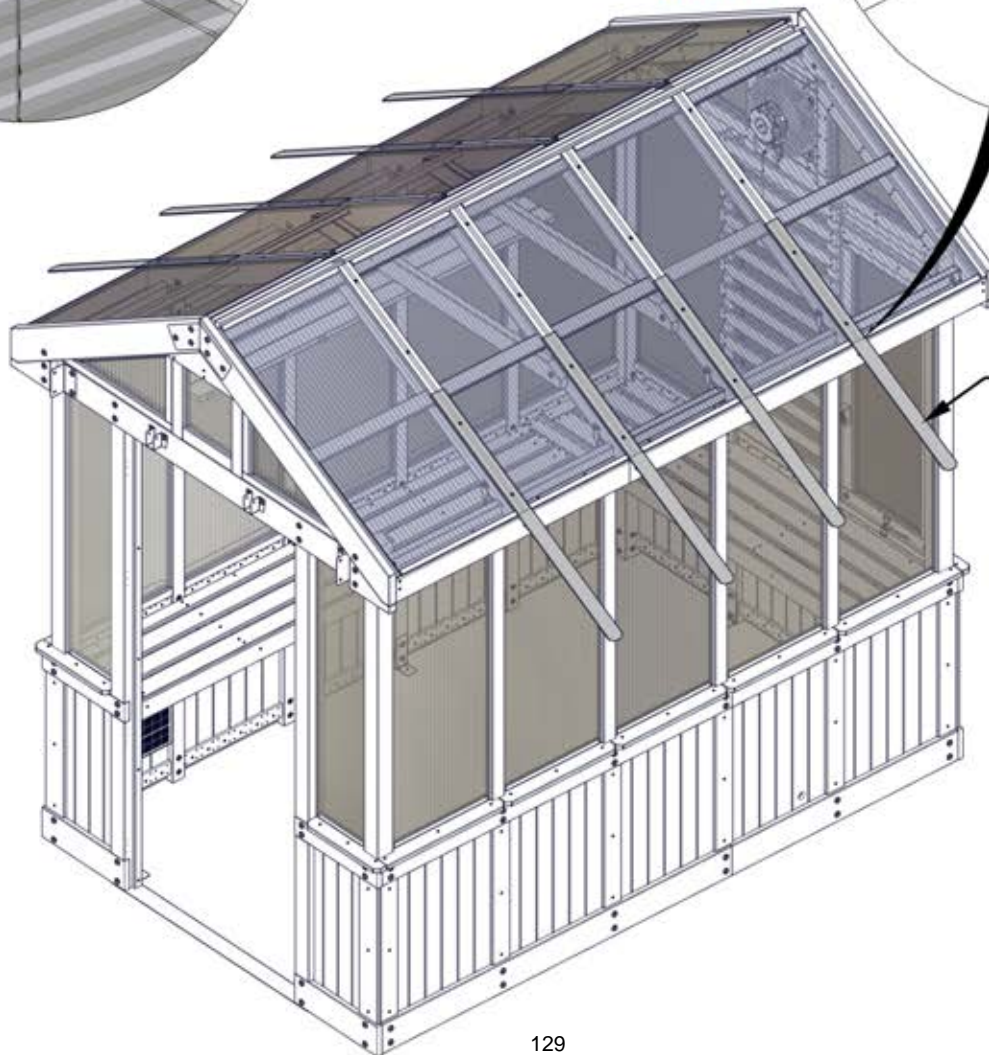

3136 (x8)  
SPLICE COVER

# STEP 107 - ROOF ASSEMBLY

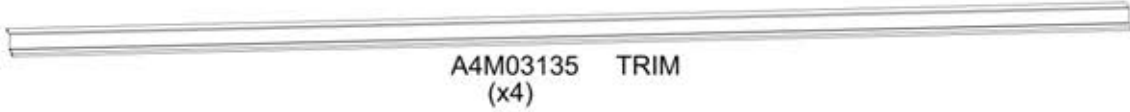

**WARNING: GLOVES ARE RECOMMENDED WHEN HANDLING STEEL.**

**REMOVE BLUE FILM FROM TRIM.**

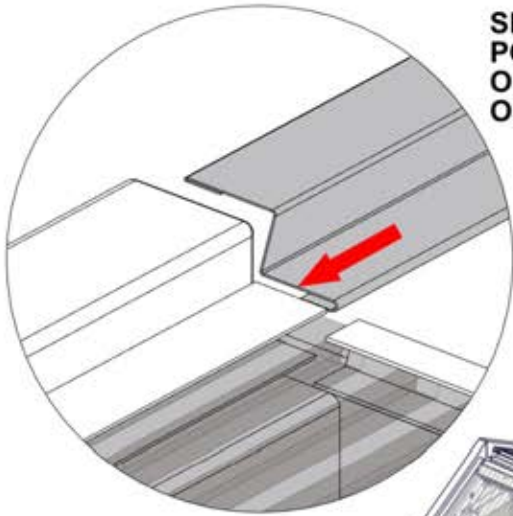

**SLIDE TRIM INTO PLACE WITH POLY CHANNEL FITTING INTO OPEN HEM. ENSURE CORRECT ORIENTATION AS SHOWN.**

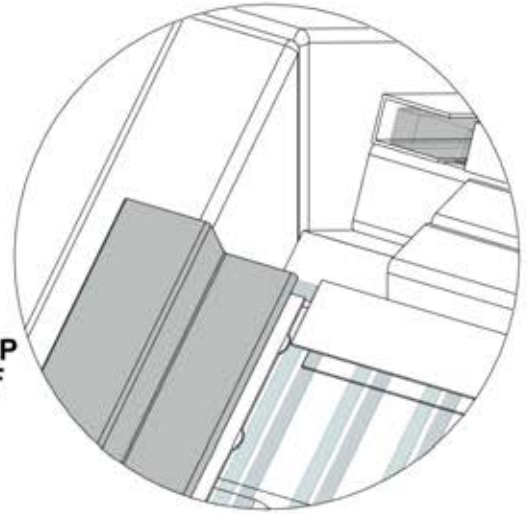

**SLIDE INTO POSITION UNTIL TOP OF TRIM IS FLUSH WITH TOP OF ROOF PANEL AS SHOWN.**

3135 (x4)  
TRIM



# STEP 108 - ROOF ASSEMBLY

QTY	PART NUMBER	DESCRIPTION
12	H101117	SCREW WOODGRIP 10-16x3/4"

INSTALL SCREWS IN CENTER OF TRIM APPROXIMATELY 1" [25mm] FROM EDGES AS SHOWN. INSTALL ANOTHER SCREW CENTERED IN BETWEEN THE TWO OUTER SCREWS.

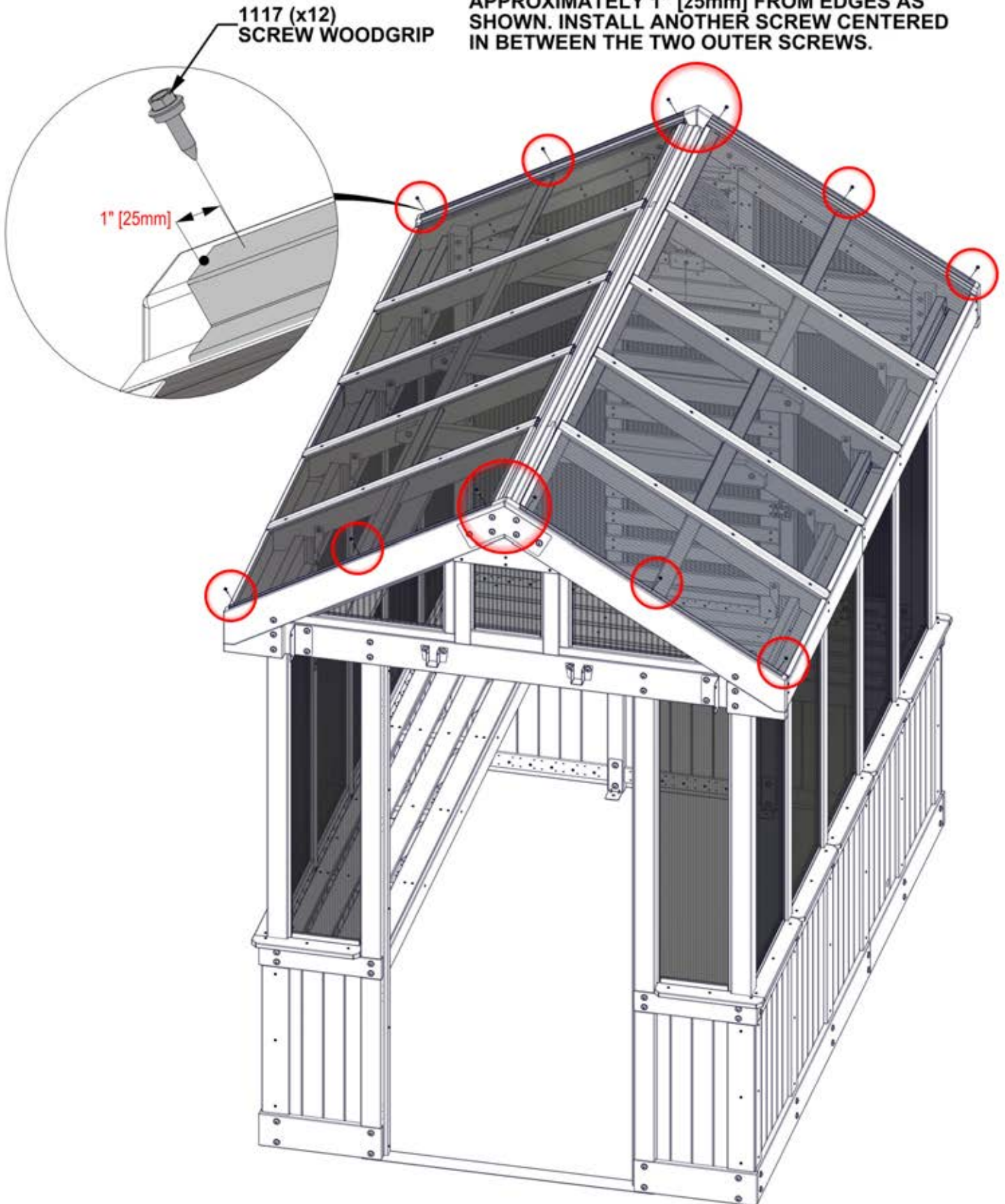

# STEP 109 - ROOF ASSEMBLY

QTY	PART NUMBER	DESCRIPTION
14	H101206	SCREW WOODGRIP 10-16x1-1/4"

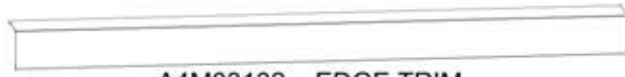

A4M03132 EDGE TRIM  
(x4)



A4M03130 EDGE TRIM SPLICE  
(x2)

**WARNING: GLOVES ARE RECOMMENDED WHEN HANDLING STEEL.**

**REMOVE BLUE FILM FROM EDGE TRIM AND EDGE TRIM SPLICE.**

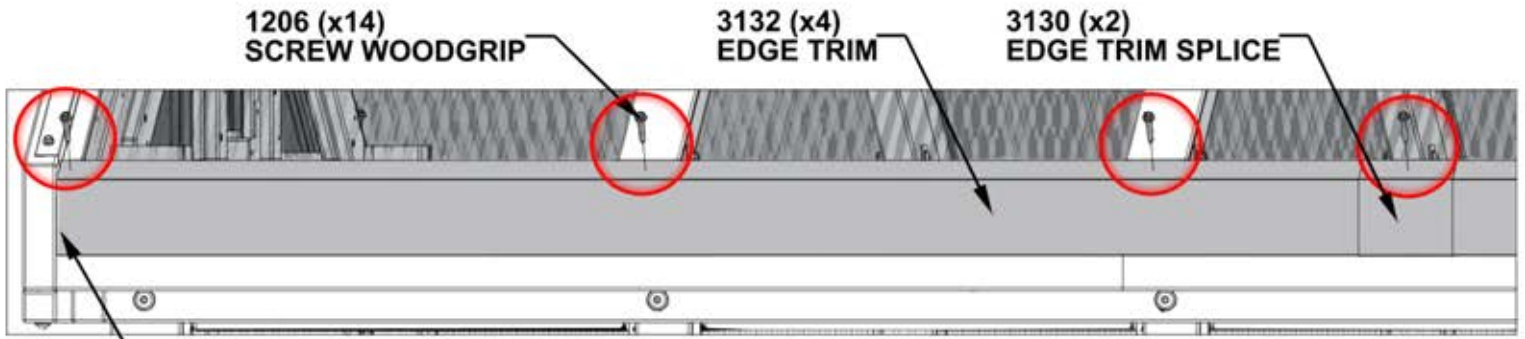

1206 (x14)  
SCREW WOODGRIP

3132 (x4)  
EDGE TRIM

3130 (x2)  
EDGE TRIM SPLICE

**EDGE TRIM IS FLUSH WITH GABLE END.**

**CENTER SCREWS ON SPLICE COVERS AND ATTACH SCREWS THROUGH TRIM AND SPLICE COVERS.**

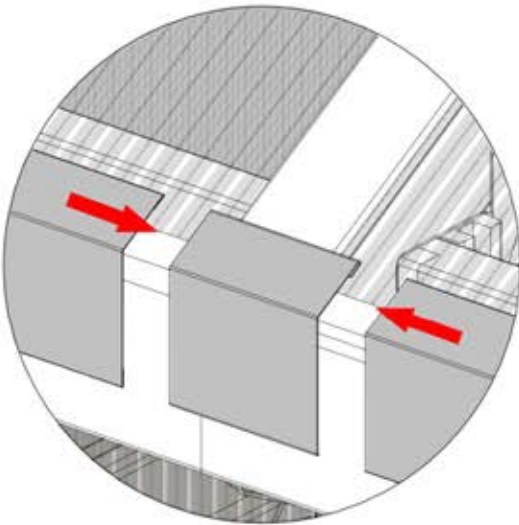

**SLIDE EDGE TRIM INTO EDGE TRIM SPLICE. ADJUST AS NEEDED.**

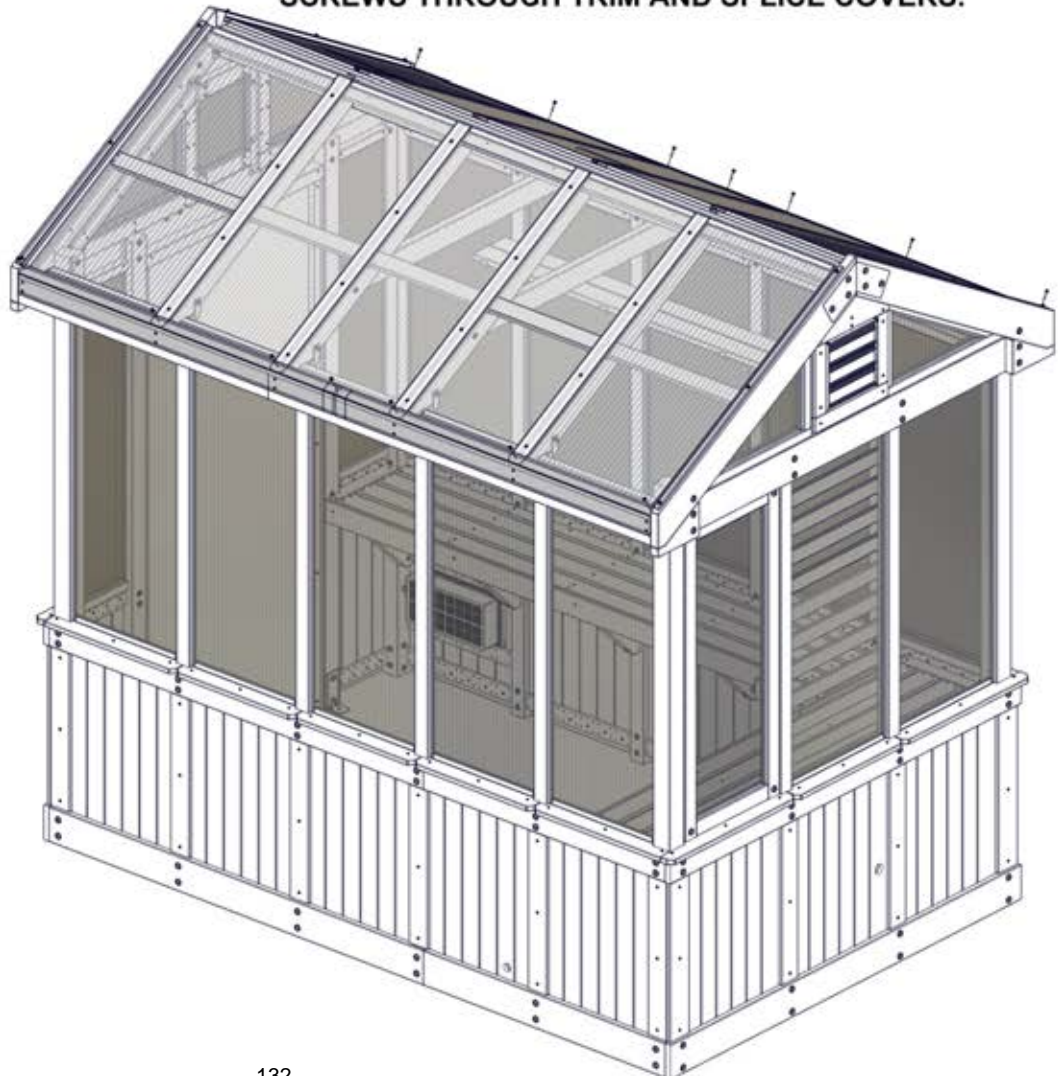

# STEP 110 - ROOF ASSEMBLY

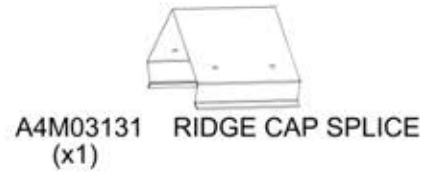
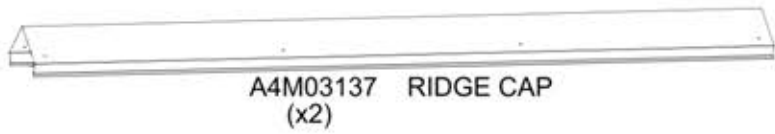

**WARNING: GLOVES ARE RECOMMENDED WHEN HANDLING STEEL.**  
**REMOVE BLUE FILM FROM RIDGE CAP AND RIDGE CAP SPLICE.**

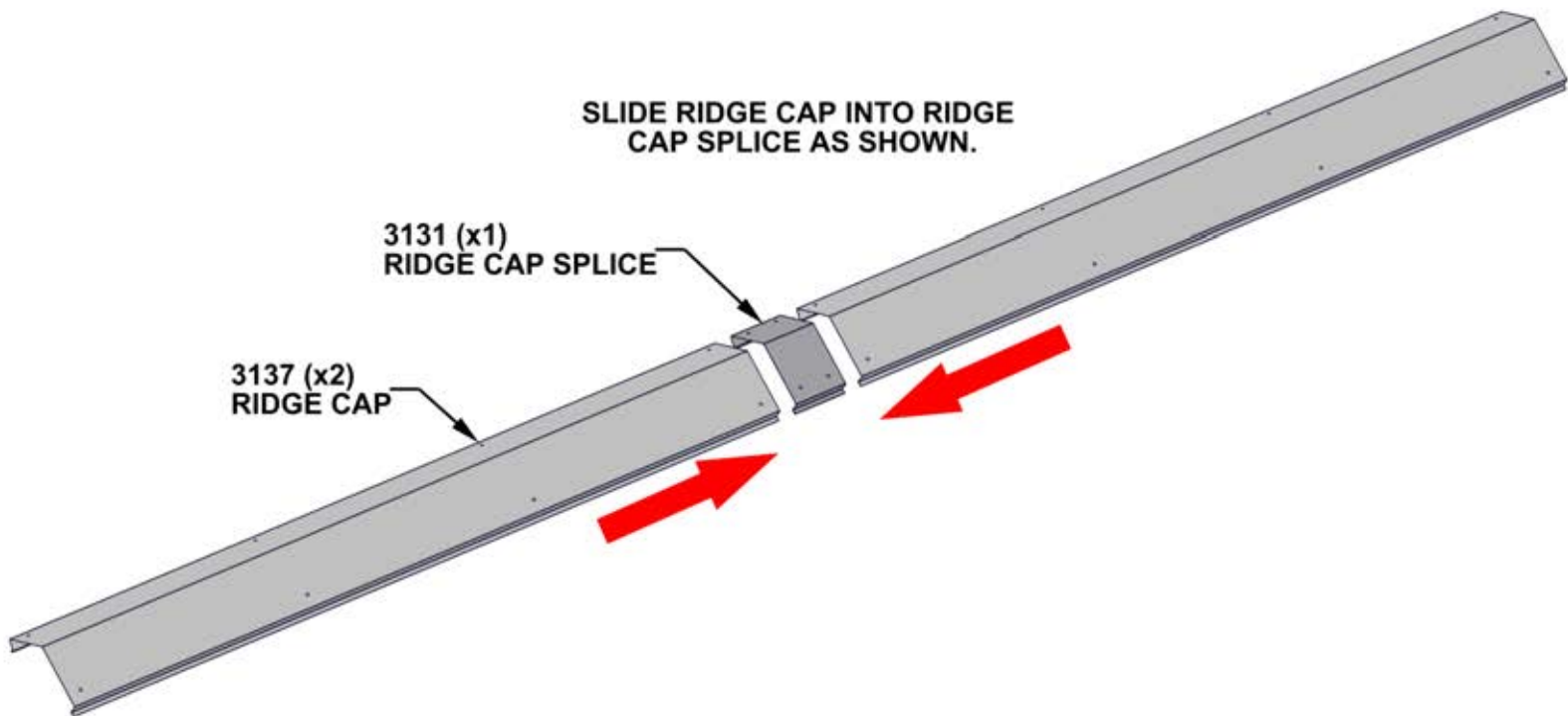

# STEP 111 - ROOF ASSEMBLY

QTY	PART NUMBER	DESCRIPTION
16	H101117	SCREW WOODGRIP 10-16x3/4"

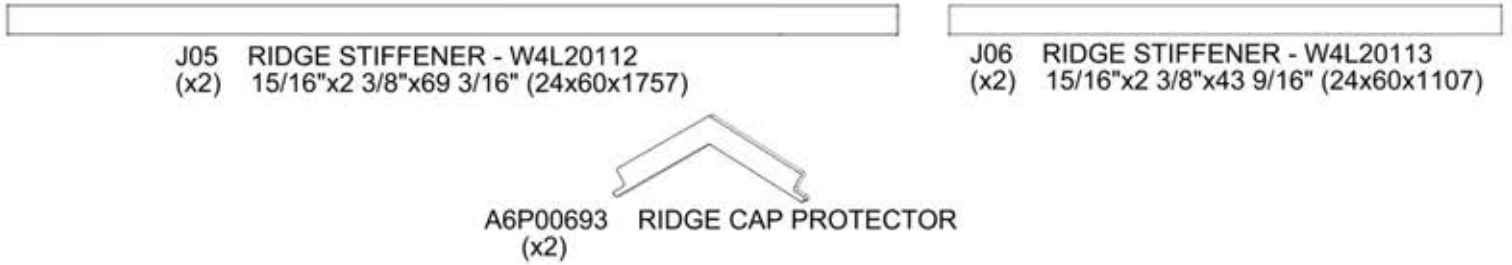

**WARNING: GLOVES ARE RECOMMENDED WHEN HANDLING STEEL.**

- ALIGN HOLES OF RIDGE CAP WITH HOLES ON RIDGE CAP SPLICE.
- ARRANGE RIDGE STIFFENERS AS SHOWN.
- ATTACH RIDGE CAP ASSEMBLY USING EIGHT SCREWS ALONG EACH SIDE.
- **CONFIRM TOTAL LENGTH OF ASSEMBLED RIDGE CAP TO BE 9'-4 7/8" +/- 1/8" [2868mm].**

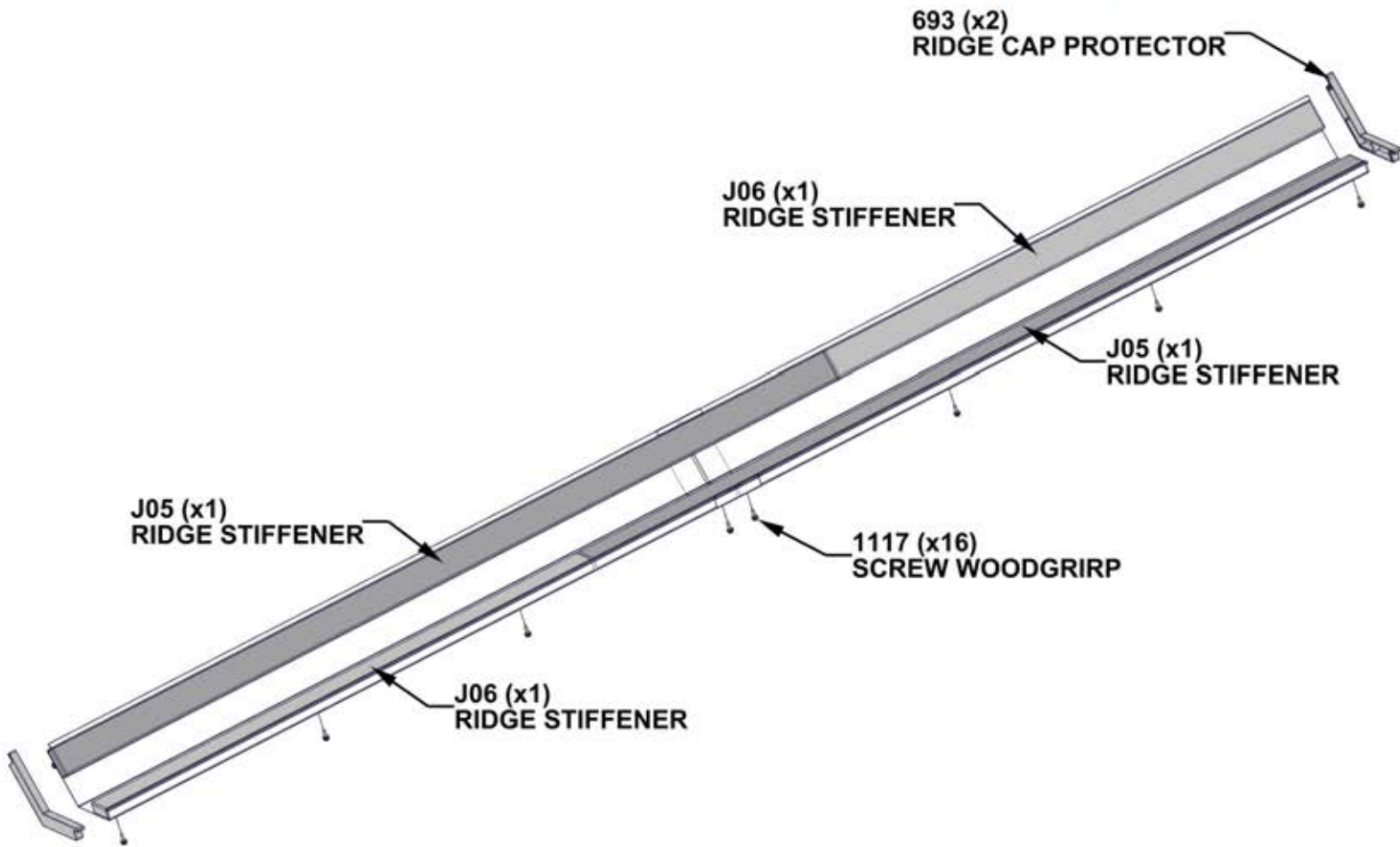

**REMOVE SPACERS FROM  
RIDGE CAP PROTECTORS  
BEFORE INSTALLING.**

# STEP 112 - ROOF ASSEMBLY

QTY	PART NUMBER	DESCRIPTION
20	H100483	SCREW PFH 8x2 1/4 BLK

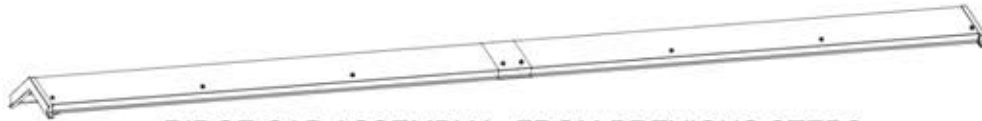

RIDGE CAP ASSEMBLY - FROM PREVIOUS STEPS

**WARNING: GLOVES ARE RECOMMENDED WHEN HANDLING STEEL.**

- TWO ADULTS WILL BE NEEDED FOR THIS STEP.
- DO NOT CLIMB ON ROOF TO INSTALL RIDGE CAP.
- RIDGE CAP HAS BEEN DESIGNED TO INSTALL WITH THE USE OF A LADDER.
- PLACE RIDGE CAP ASSEMBLY ON TOP OF ROOF RIDGE UNTIL BOTH ENDS ARE SEATED INSIDE THE GABLES AS SHOWN.
- ONE ADULT MUST KEEP DOWNWARD PRESSURE ON THE RIDGE CAP ASSEMBLY WHILE THE SECOND ADULT IS INSIDE ATTACHING THE SCREWS.
- INSTALL SCREWS THROUGH PILOT HOLES IN ROOF PANELS INTO RIDGE CAP ASSEMBLY.

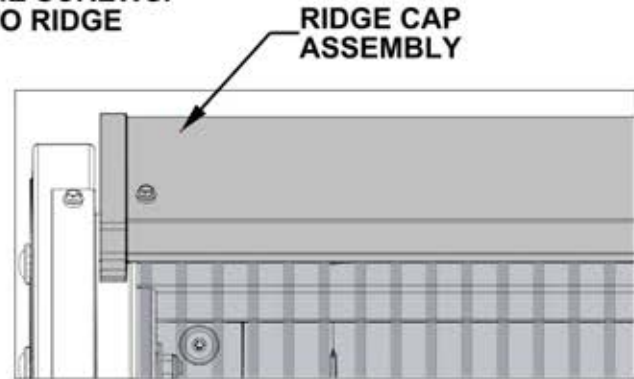
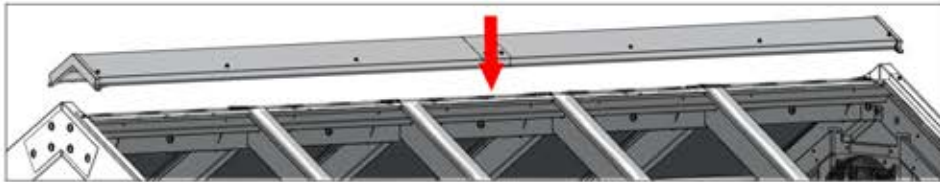

USE PHILLIPS BIT EXTENSION TO ATTACH SCREWS.

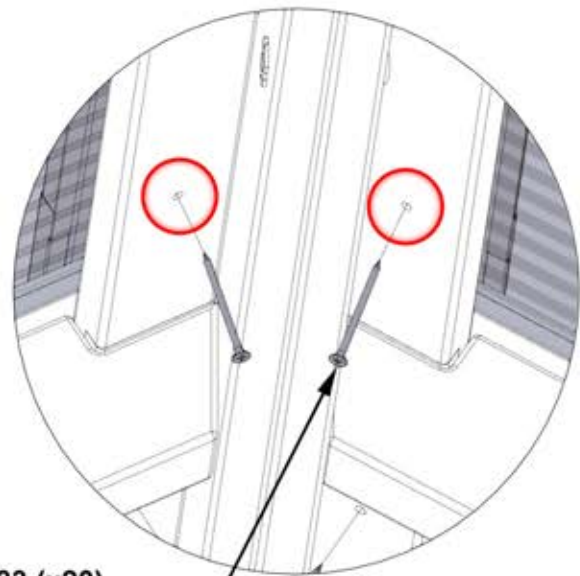
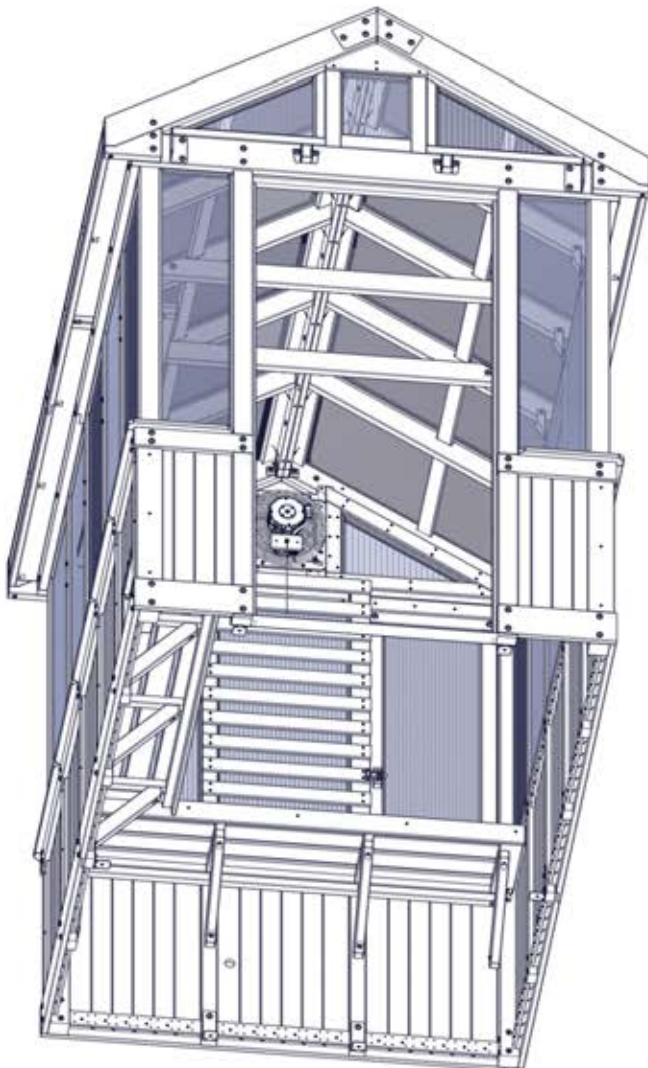

483 (x20)  
SCREW - 2 1/4"

# STEP 113 - PERGOLA ASSEMBLY

QTY	PART NUMBER	DESCRIPTION
8	H100200	SCREW PFH 8x1 1/2 BLK



B05 POST - W4L20072  
(x1) 3"x3"x86 1/16" (76x76x2186)



B06 POST - W4L20073  
(x1) 3"x3"x86 1/16" (76x76x2186)



A6P00573 POST FOOT 3x3  
(x2)

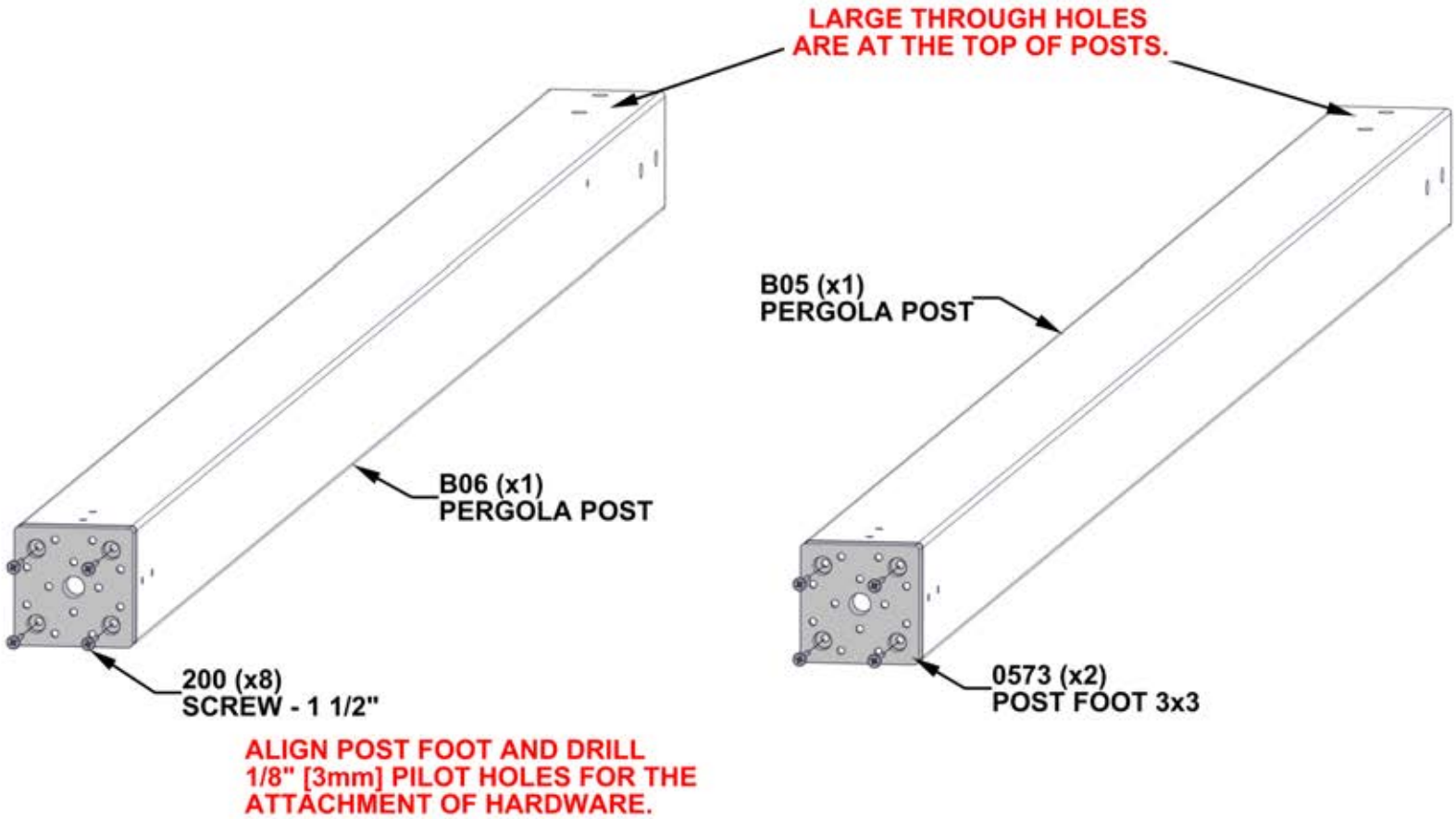

# STEP 114 - PERGOLA ASSEMBLY

QTY	PART NUMBER	DESCRIPTION
4	H100195	BOLT WH 5/16x2 3/4 BLK
8	H100198	WASHER LOCK EXT 8x19
8	H100379	TNUT-5/16" BLK
2	H100405	WASHER LOCK EXT 6x15
4	H100513	BOLT WH 5/16x4 1/4 BLK
2	H100792	LAG SCREW WH 1/4x3 BLK

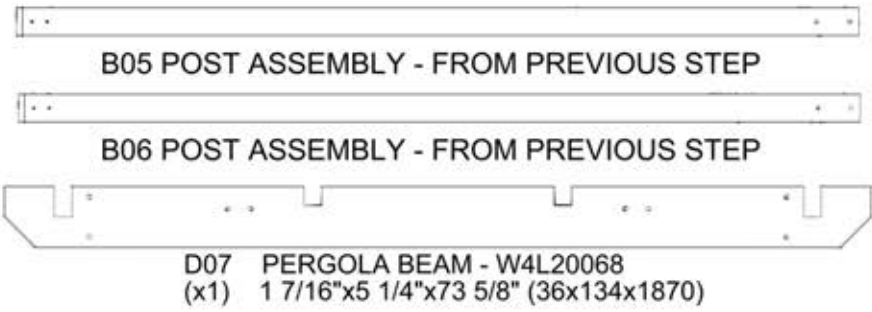

**- INSERT T-NUTS FIRST.**

- TO AVOID SPLITTING POSTS, MAKE SURE LAG SCREWS GO INTO PILOT HOLES.
- IF BOLT DOES NOT ENGAGE WITH T-NUT, CHECK FOR SAWDUST BUILD UP IN HOLES. CLEAN WITH A LONG SCREW DRIVER IF NEEDED.

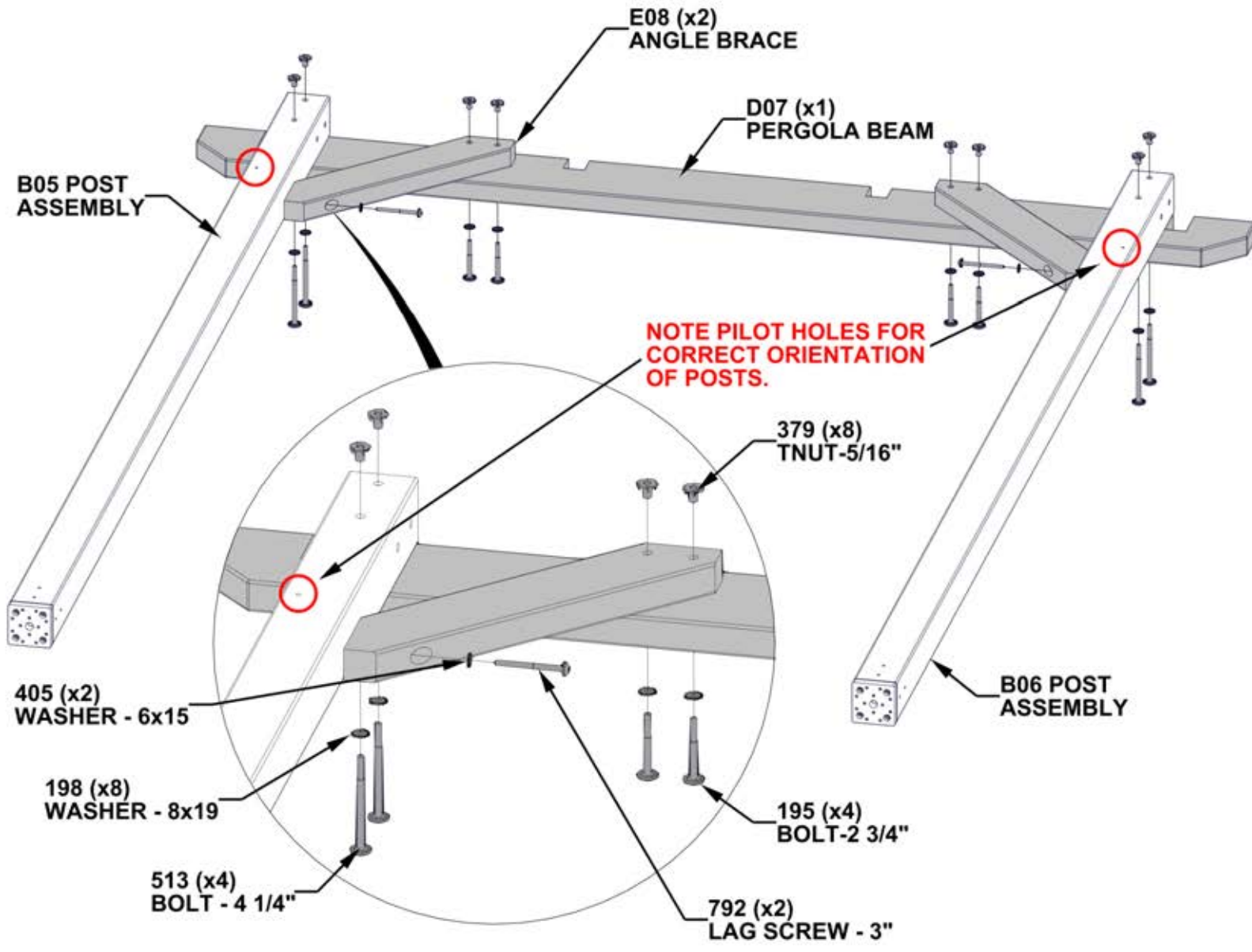

**SQUARE POSTS TO BEAM AND FULLY TIGHTEN ALL HARDWARE.**

# STEP 115 - PERGOLA ASSEMBLY

QTY	PART NUMBER	DESCRIPTION
4	H100195	BOLT WH 5/16x2 3/4 BLK
8	H100198	WASHER LOCK EXT 8x19
8	H100379	TNUT-5/16" BLK
4	H100405	WASHER LOCK EXT 6x15
4	H100513	BOLT WH 5/16x4 1/4 BLK
4	H100792	LAG SCREW WH 1/4x3 BLK



D08 PERGOLA RAFTER - W4L20069  
(x2) 1 7/16"x5 1/4"x44 7/16" (36x134x1128)



E08 ANGLE BRACE - W4L20074  
(x2) 1 7/16"x3 3/8"x18 11/16" (36x86x474)

- INSERT T-NUTS FIRST.
- TO AVOID SPLITTING POSTS, MAKE SURE LAG SCREWS GO INTO PILOTHOLES.
- IF BOLT DOES NOT ENGAGE WITH T-NUT, CHECK FOR SAWDUST BUILD UP IN HOLES. CLEAN WITH A LONG SCREW DRIVER IF NEEDED.

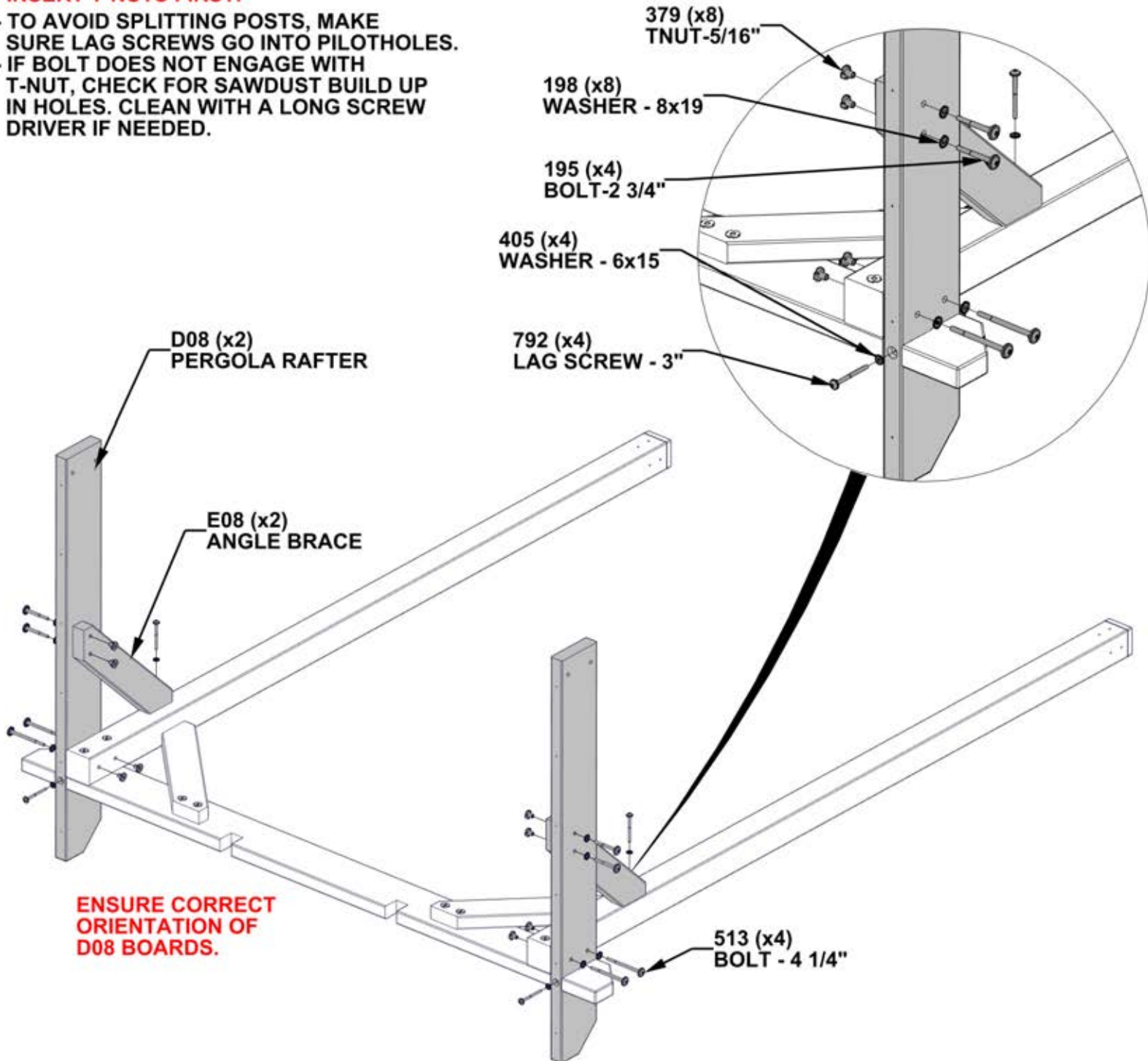

**ENSURE CORRECT ORIENTATION OF D08 BOARDS.**

**SQUARE POSTS TO BEAM AND FULLY TIGHTEN ALL HARDWARE.**

# STEP 116 - PERGOLA ASSEMBLY

QTY	PART NUMBER	DESCRIPTION
4	H100198	WASHER LOCK EXT 8x19
4	H100457	BOLT WH 5/16x2 BLK
4	H100479	NUT LOCK 5/16 BLK
4	H100630	WASHER FLAT 8x19 BLK

**TWO ADULTS WILL BE NEEDED FOR THIS STEP.**

STAND UP PERGOLA ASSEMBLY FROM PREVIOUS STEPS AND ATTACH AS SHOWN.

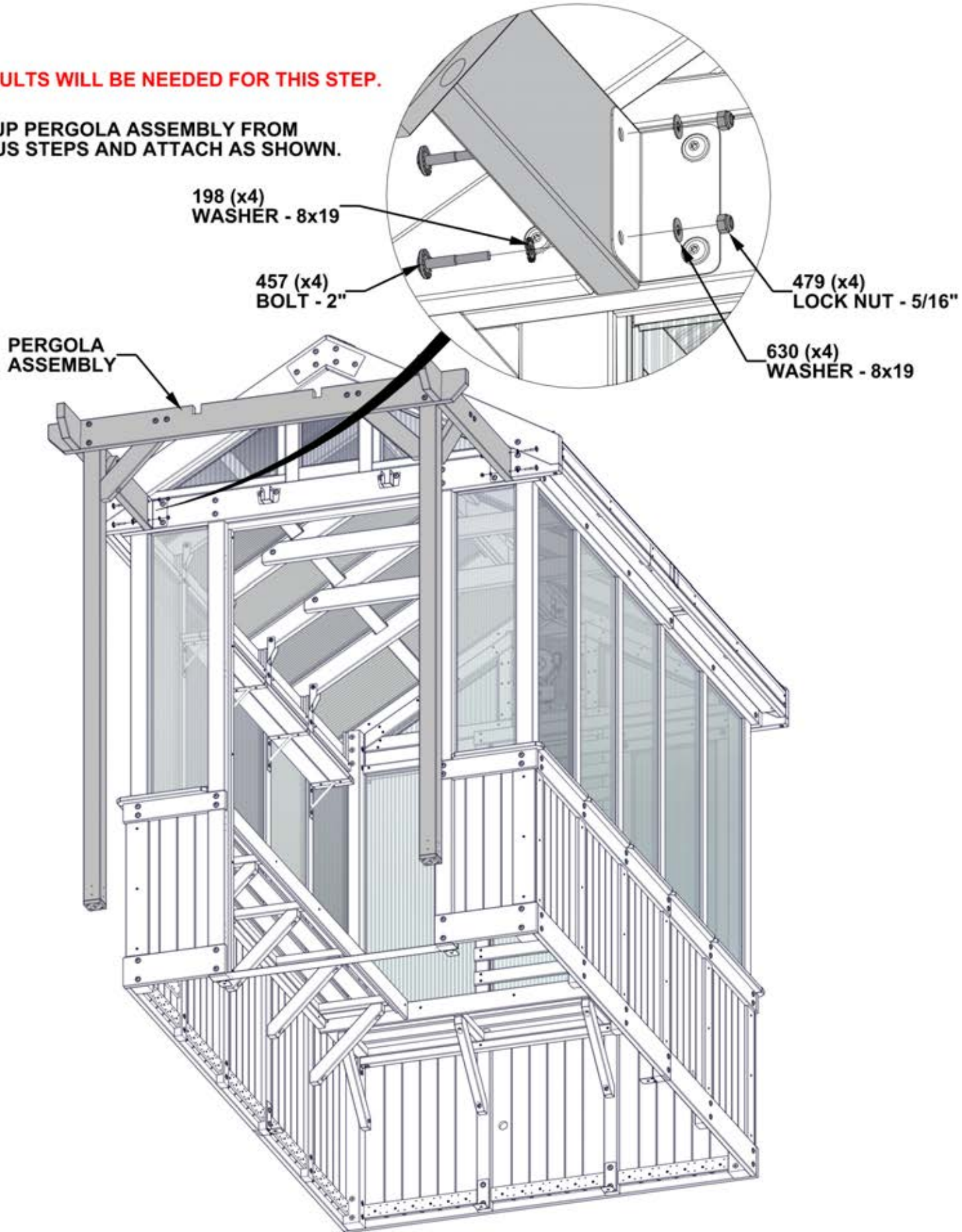

# STEP 117 - PERGOLA ASSEMBLY

QTY	PART NUMBER	DESCRIPTION
2	H100405	WASHER LOCK EXT 6x15
2	H100488	BOLT WH 1/4x2 BLK
2	H100630	WASHER FLAT 8x19 BLK
2	H100653	NUT LOCK 1/4 BLK
2	H100792	LAG SCREW WH 1/4x3 BLK



E07 PERGOLA RAFTER - W4L20070  
(x2) 1 7/16"x3 3/8"x44 7/16" (36x86x1128)

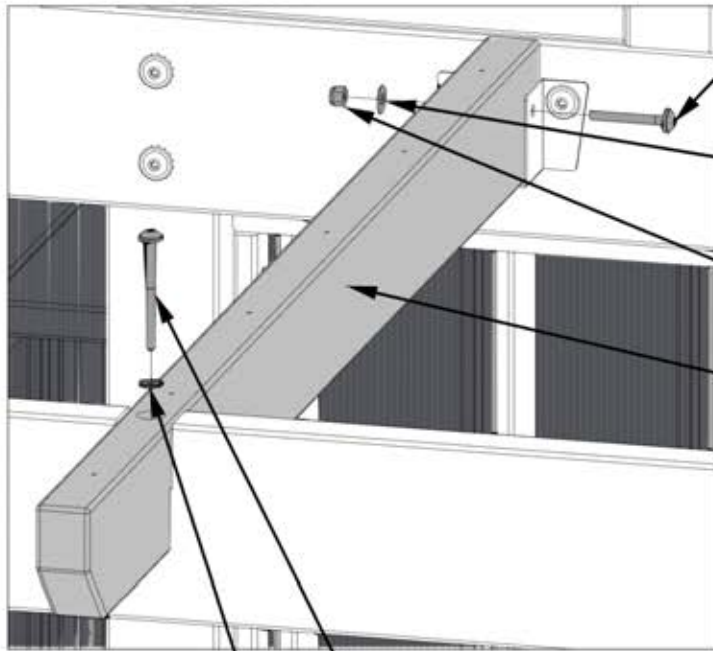

488 (x2)  
BOLT - 2"

630 (x2)  
WASHER - 8x19

653 (x2)  
LOCK NUT - 1/4"

E07 (x2)  
PERGOLA RAFTER

**ENSURE CORRECT ORIENTATION  
OF E07 BOARDS AS SHOWN.**

792 (x2)  
LAG SCREW - 3"

405 (x2)  
WASHER - 6x15

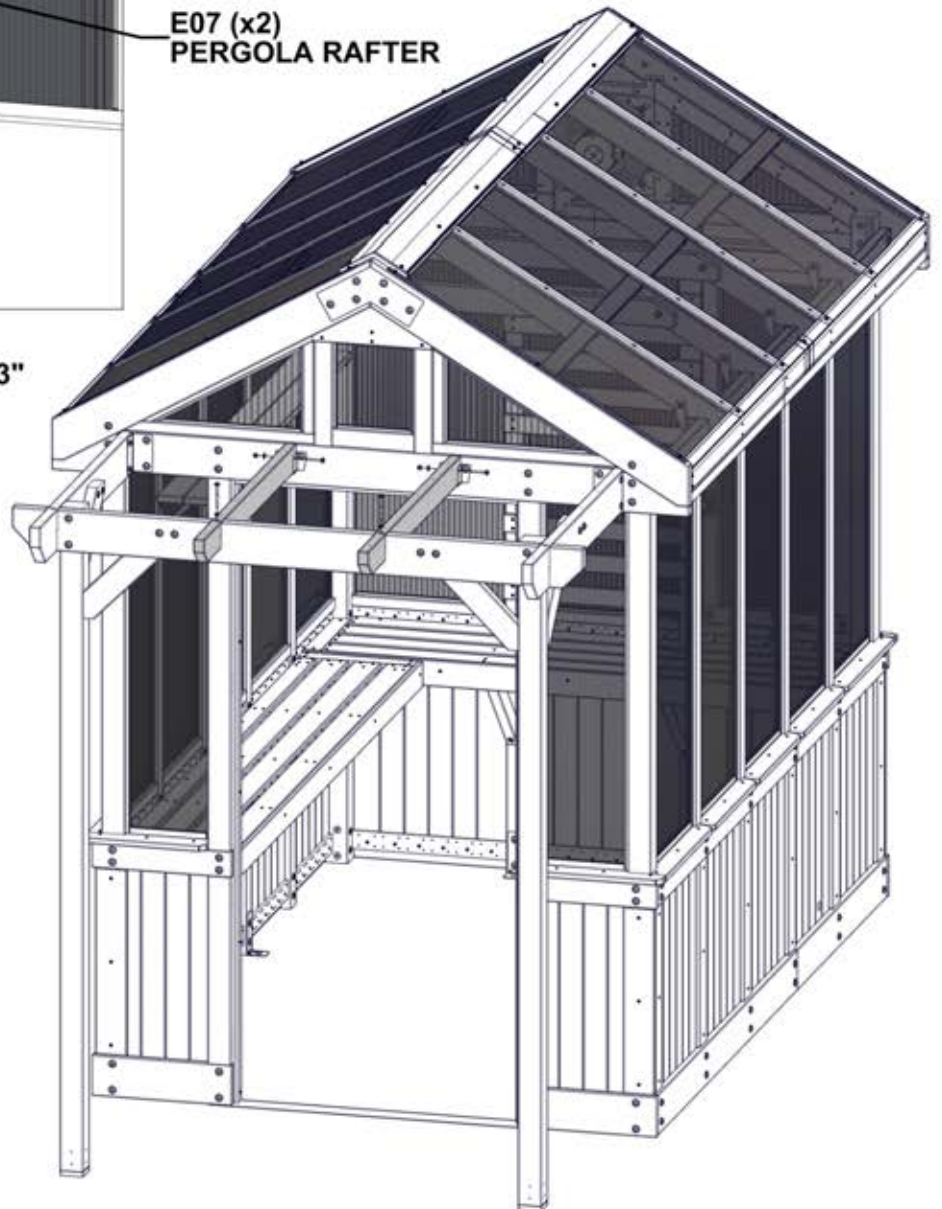

# STEP 118 - PERGOLA ASSEMBLY

QTY	PART NUMBER	DESCRIPTION
24	H100387	SCREW PFH 8x1 1/4 BLK



N04 PERGOLA PURLIN - W4L20071  
(x6) 5/8"x2 3/8"x71 1/4" (16x60x1810)

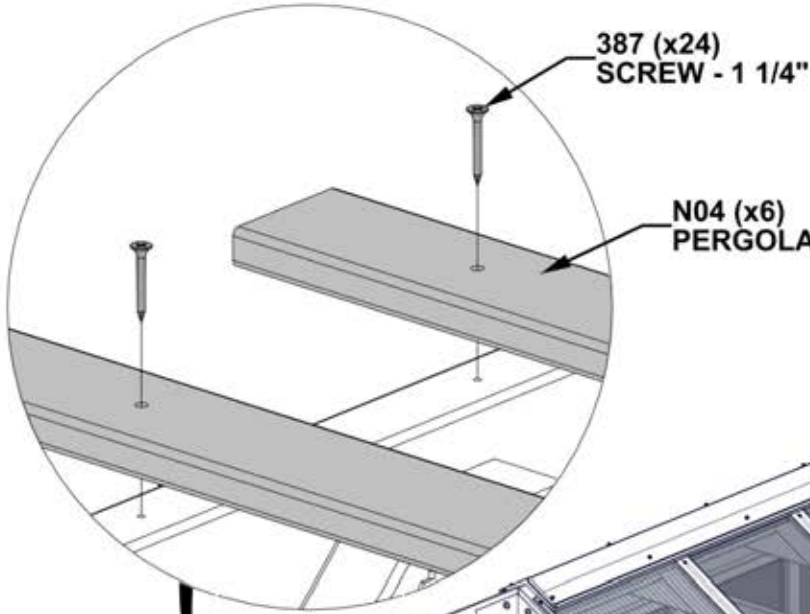

387 (x24)  
SCREW - 1 1/4"

N04 (x6)  
PERGOLA PURLIN

**ATTACH PURLINS USING PILOT HOLES IN PERGOLA RAFTERS.**

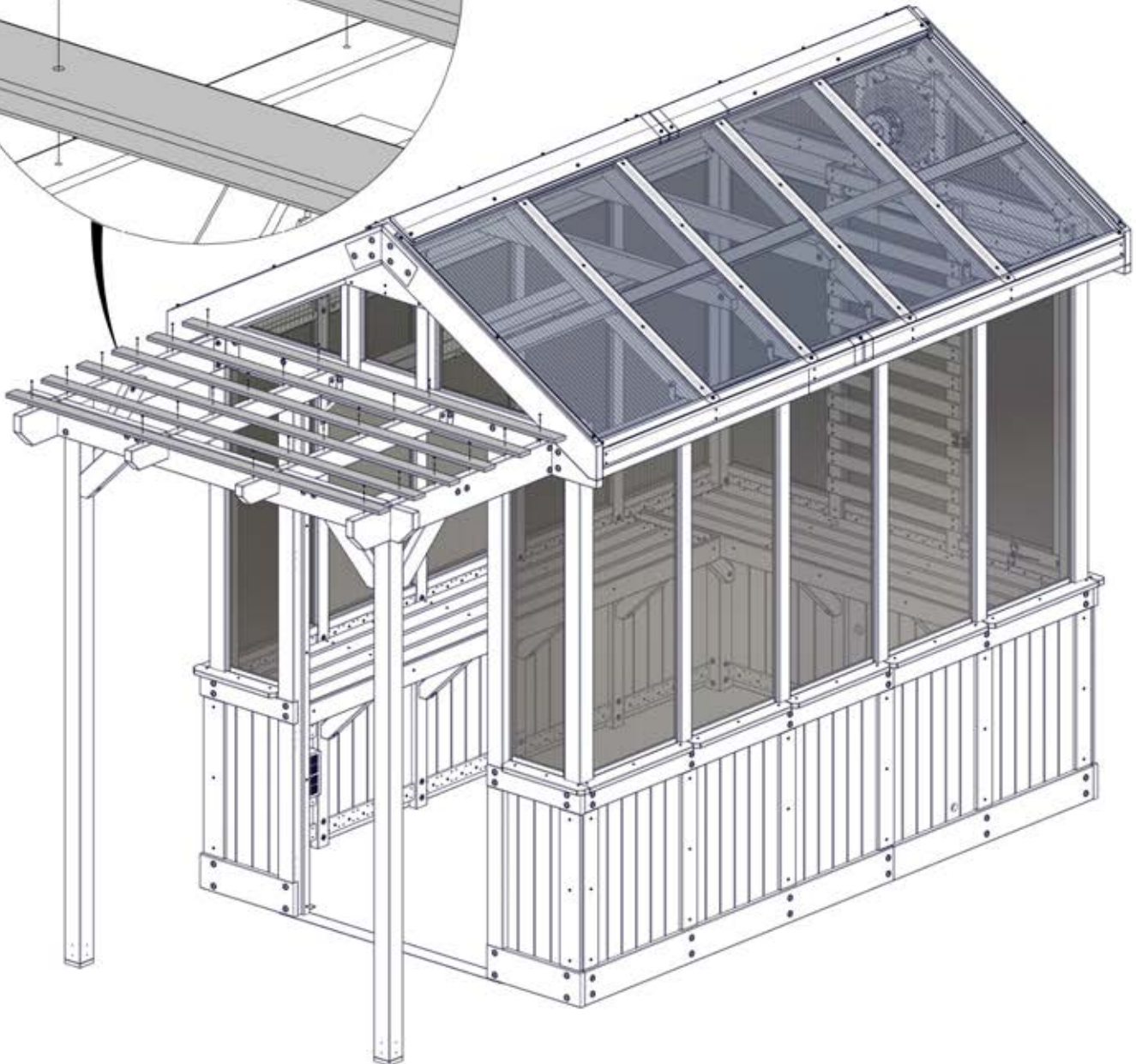

# STEP 119 - PERGOLA ASSEMBLY

QTY	PART NUMBER	DESCRIPTION
16	H100460	LAG SCREW WH 1/4x1 BLK



A4M02092 POST ANCHOR PLATE  
(x4)



A4M02089 STEEL POST PLATE  
(x4)

- 2092 POST ANCHORING PLATES GO ON FRONT AND BACK OF POSTS.
- 2089 STEEL POST PLATES GO ON BOTH SIDES OF POSTS.

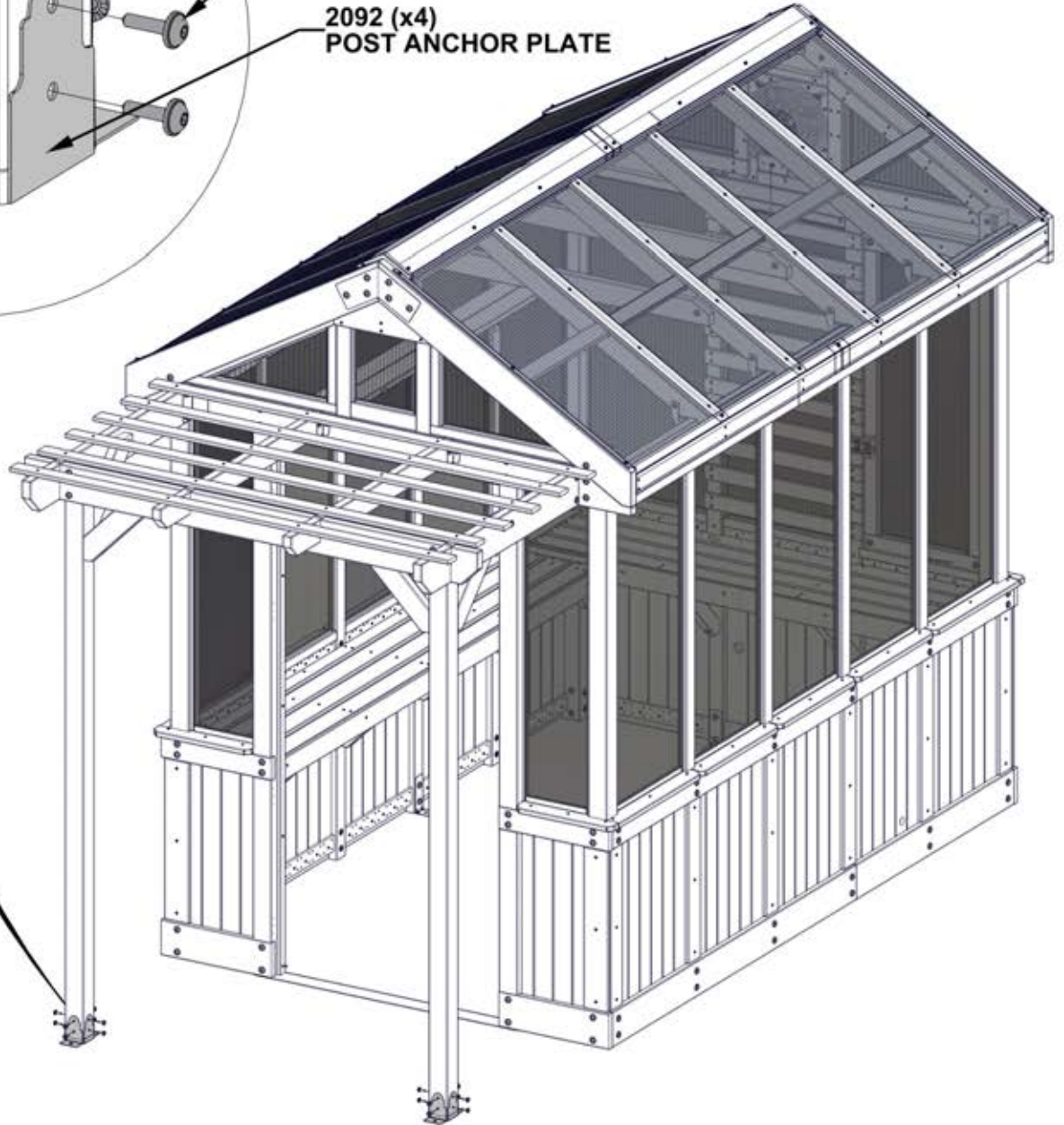
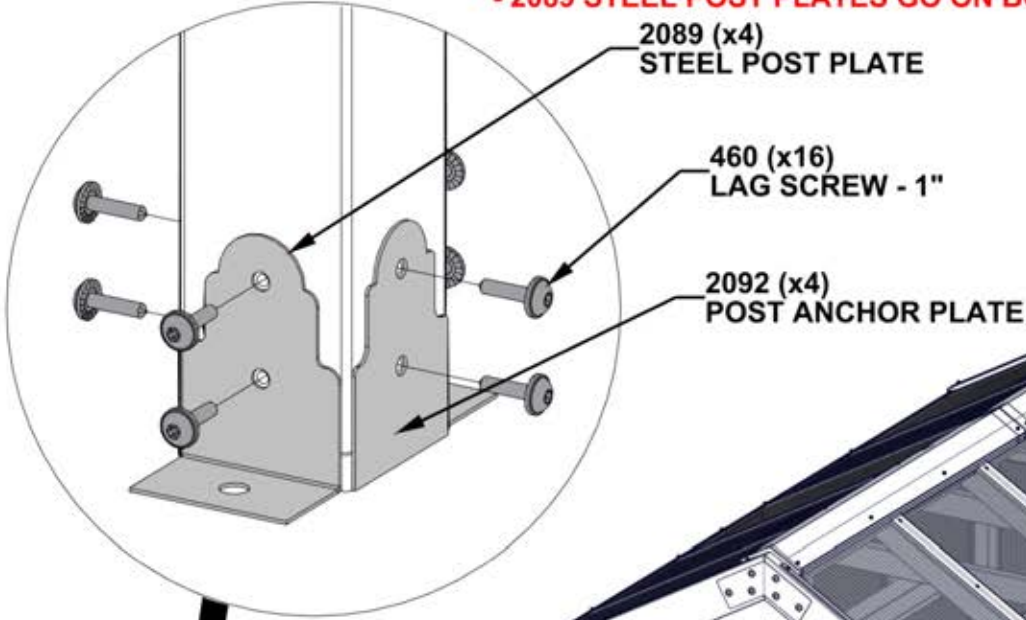

# STEP 120 - BACK WALL ASSEMBLY

QTY	PART NUMBER	DESCRIPTION
2	H100200	SCREW PFH 8x1 1/2 BLK
2	H100411	SCREW PFH 8x5/8 BLK

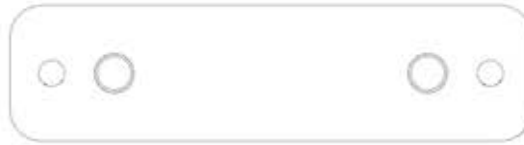

A4M01292 MOUNTING BRACKET  
(x2)

INCLUDED WITH THE ELECTRICAL ENCLOSURE

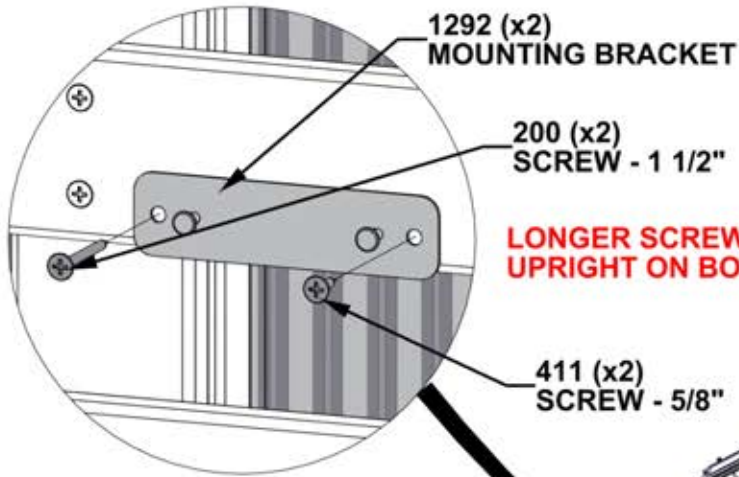

1292 (x2)  
MOUNTING BRACKET

200 (x2)  
SCREW - 1 1/2"

**LONGER SCREWS ATTACH TO UPRIGHT ON BOTH BRACKETS.**

411 (x2)  
SCREW - 5/8"

- DRILL PILOT HOLES USING AN 1/8" [3mm] DRILL BIT.
- USE MOUNTING BRACKETS AND DIMENSIONS AS A GUIDE.

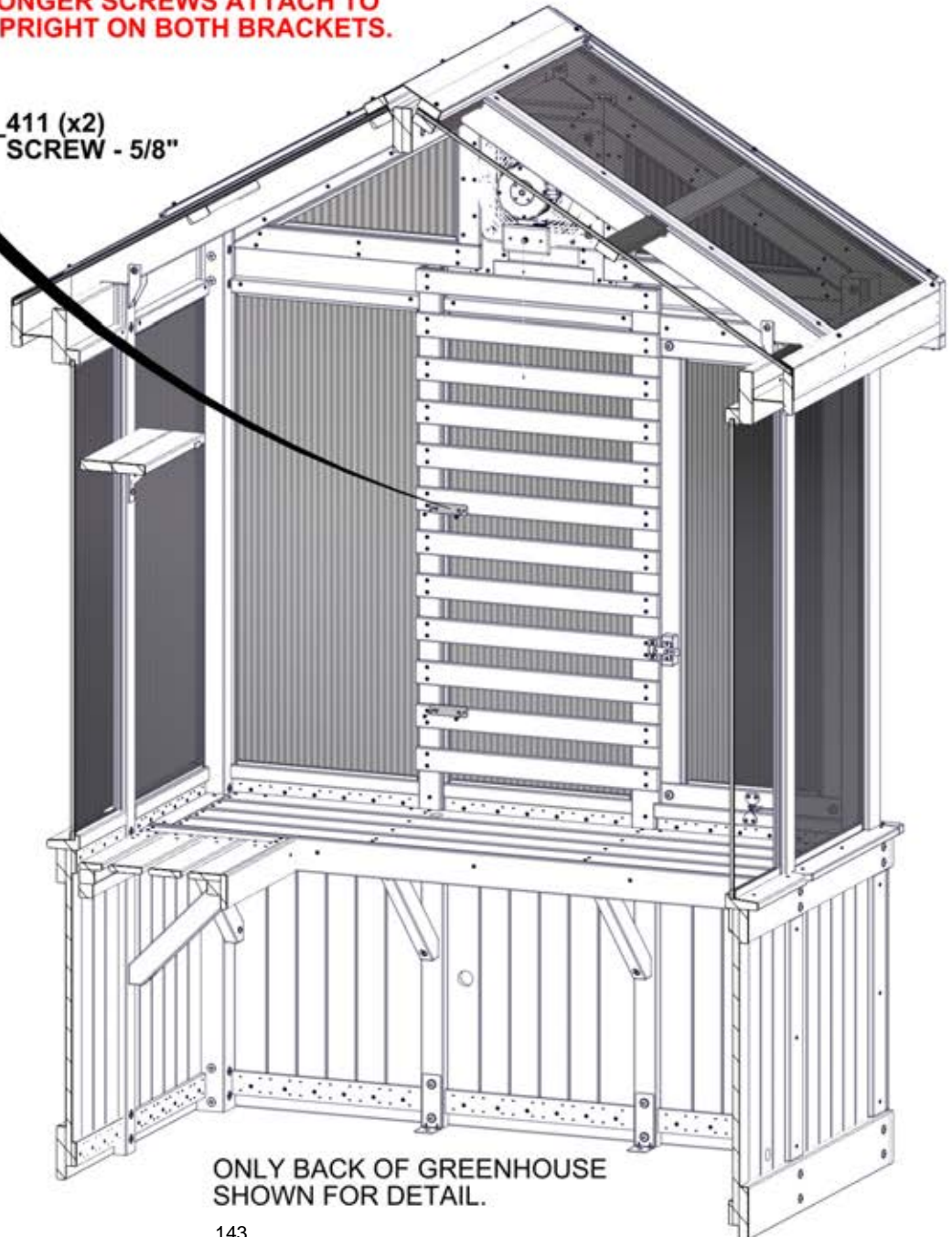
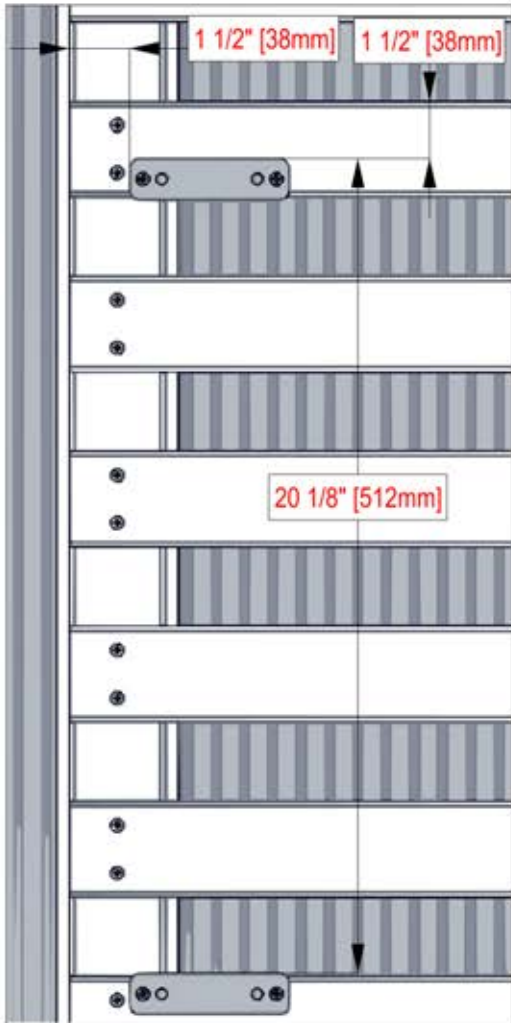

ONLY BACK OF GREENHOUSE SHOWN FOR DETAIL.

**ATTACH BRACKETS USING DIMENSIONS GIVEN.**

# STEP 121 - BACK WALL ASSEMBLY



**HANG ELECTRICAL ENCLOSURE ON THE MOUNTING BRACKETS, THEN RUN ELECTRICAL CORD THROUGH HOLE IN TABLE AS SHOWN.**

5413 (x1)  
ELECTRICAL ENCLOSURE

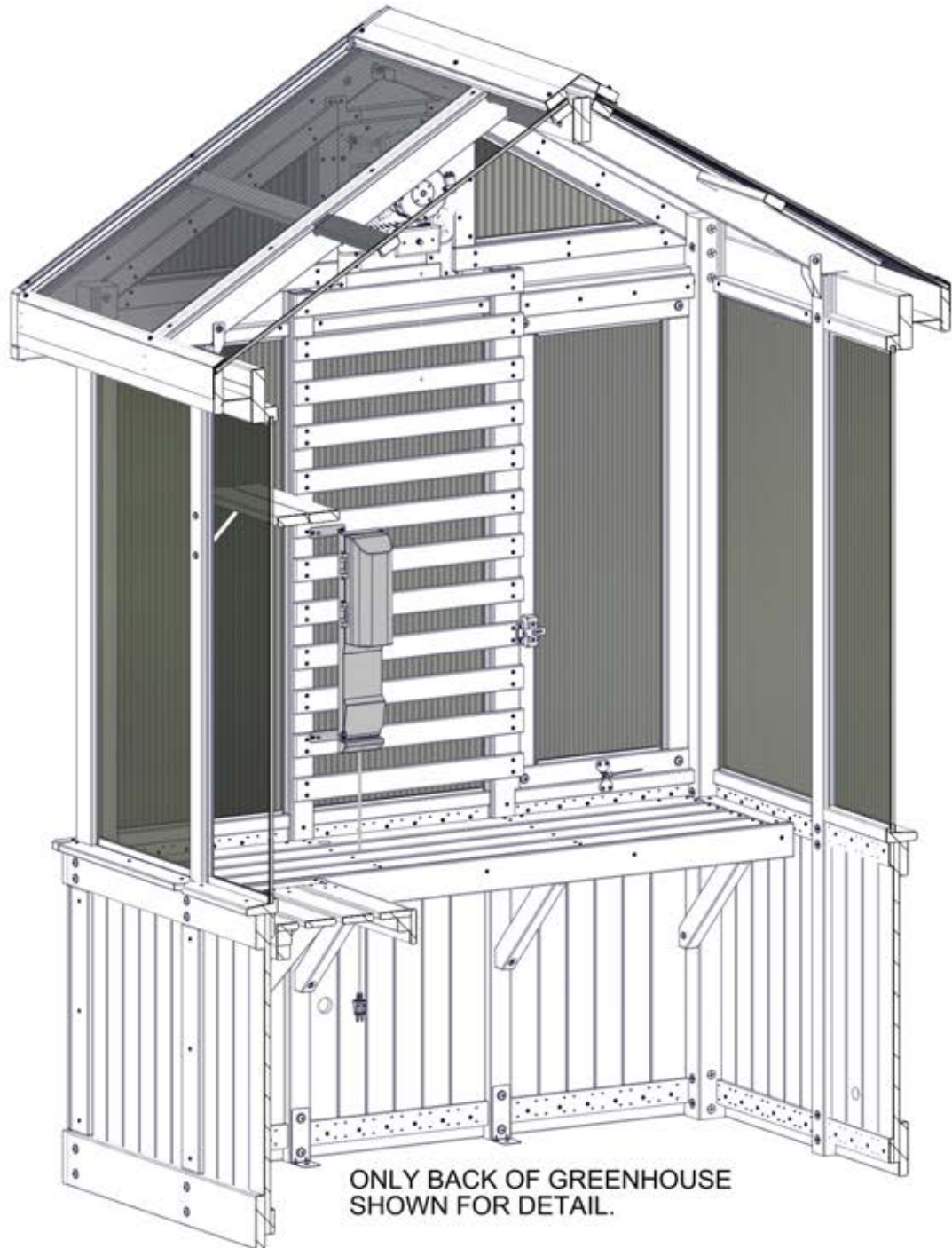
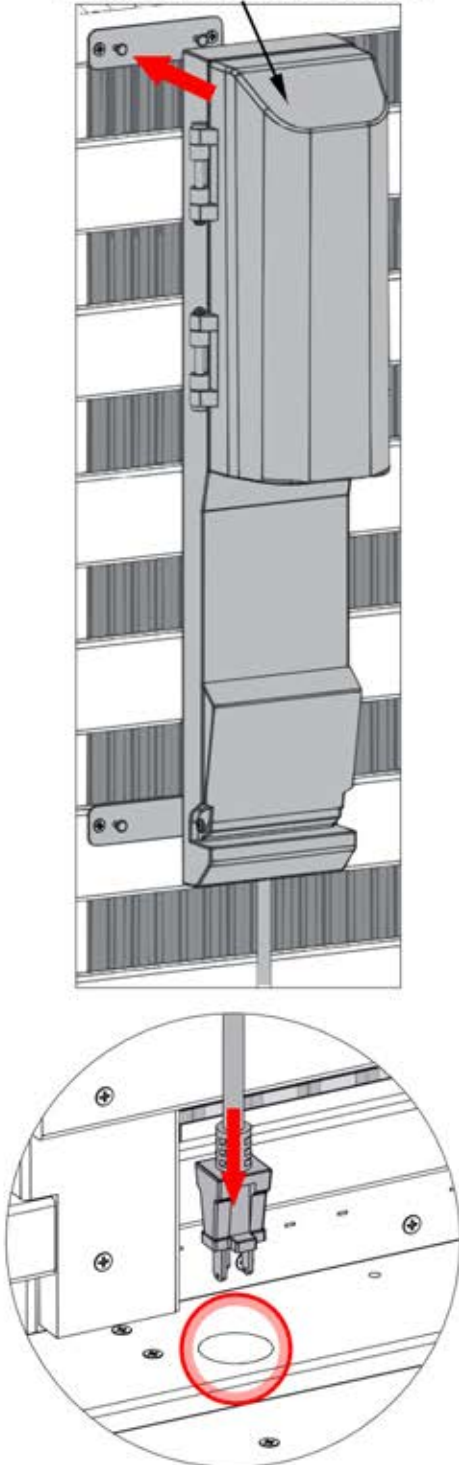

# STEP 122 - BACK WALL ASSEMBLY

QTY	PART NUMBER	DESCRIPTION
1	H100411	SCREW PFH 8x5/8 BLK

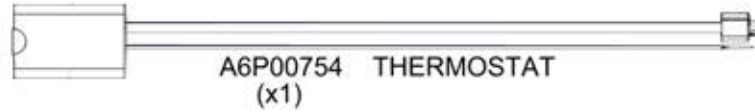

- LOCATE THERMOSTAT IN A DESIRED LOCATION CLOSE TO THE ELECTRICAL ENCLOSURE.
- INSTALL SCREW LEAVING IT PARTIALLY STICKING OUT AND HANG THERMOSTAT.
- HANG THE PROBE IN AN ELEVATED LOCATION.
- SEE THERMOSTAT MANUAL FOR OPERATING INSTRUCTIONS.

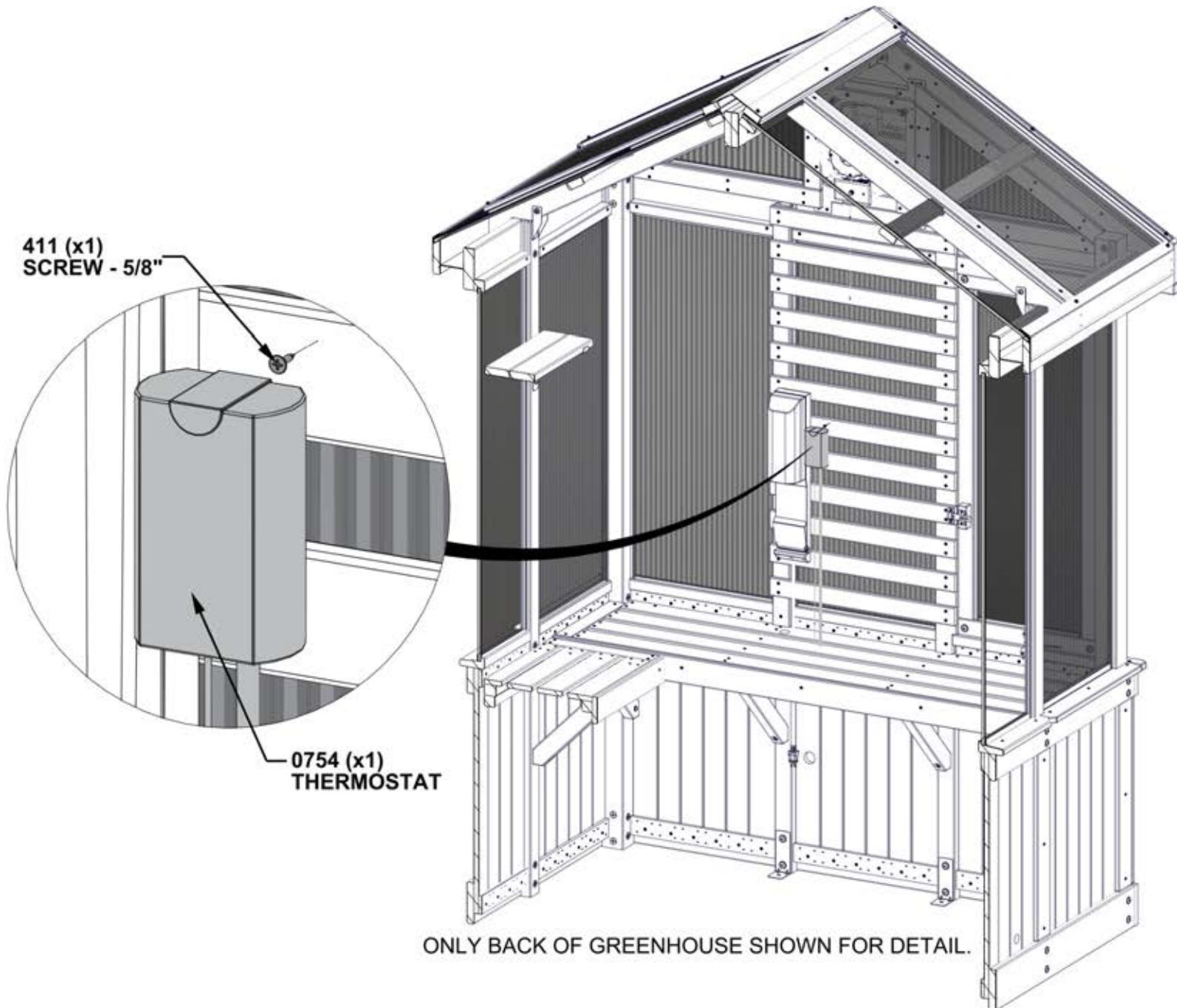

# STEP 123 - DOOR ASSEMBLY

QTY	PART NUMBER	DESCRIPTION
12	H100385	SCREW PFH 8x1 BLK



DA01 DOOR ASSEMBLY - W2A04072  
(x1) 1 7/8"x36 9/16"x80" (48x928x2032)



A4M0557 HINGE  
(x4)

ALIGN PILOT HOLES IN HINGES WITH PILOT HOLES ON DOOR.

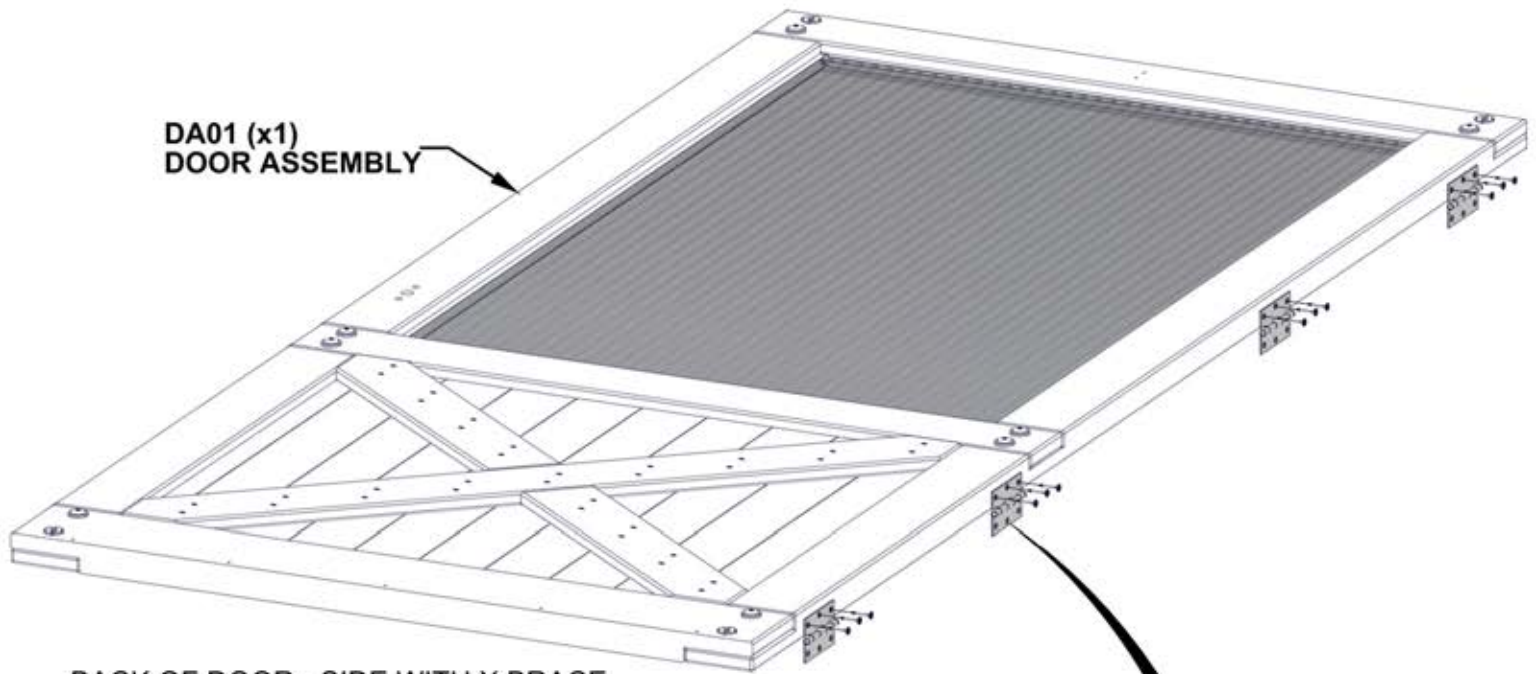

DA01 (x1)  
DOOR ASSEMBLY

BACK OF DOOR - SIDE WITH X BRACE

**WITH THE DOOR LAYING WITH THE BACK FACING UP AS SHOWN, ATTACH HINGES. CORRECT ORIENTATION OF HINGES IS CRITICAL.**

0557 (x4)  
HINGE ASSEMBLY

**NOTE DIRECTION OF BARREL ON HINGES.**

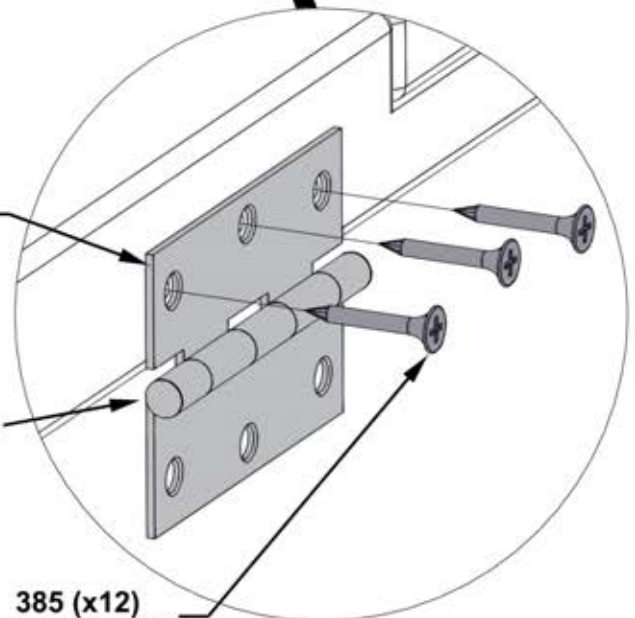

385 (x12)  
SCREW - 1"

# STEP 124 - DOOR ASSEMBLY

QTY	PART NUMBER	DESCRIPTION
12	H100385	SCREW PFH 8x1 BLK

LIFT DOOR INTO PLACE AND ATTACH AS SHOWN.

**ALIGN HOLES IN HINGES WITH  
PILOT HOLES IN DOOR FRAME.**

385 (x12)  
SCREW - 1"

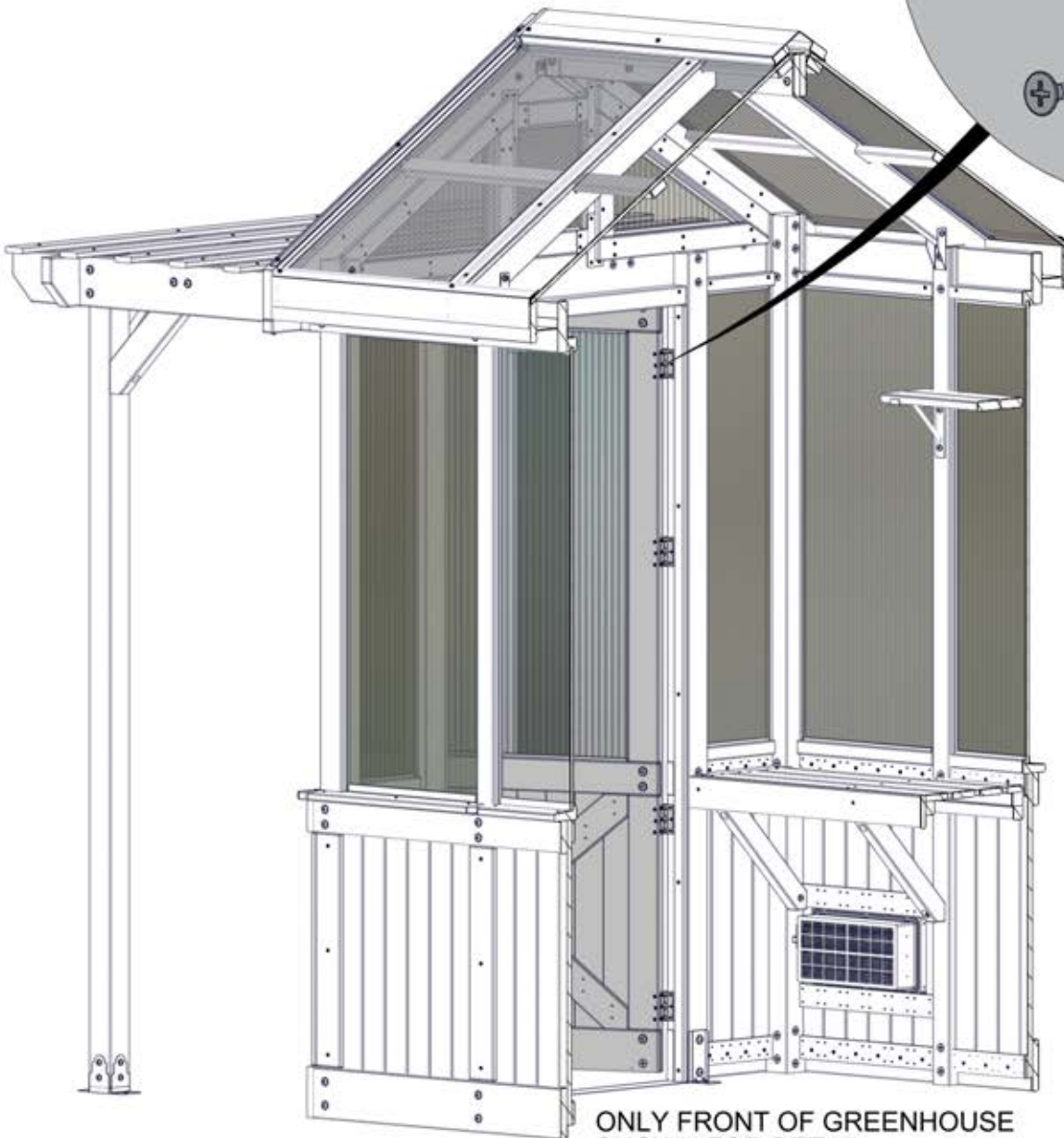
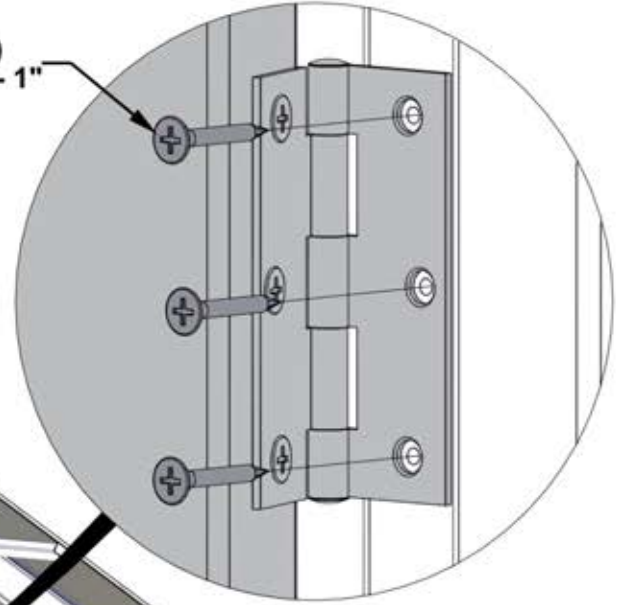

ONLY FRONT OF GREENHOUSE  
SHOWN FOR DETAIL.

# STEP 125 - DOOR ASSEMBLY

QTY	PART NUMBER	DESCRIPTION
2	H101259	SCREW POH 8x1 3/4 SS



A4M02410 STORM DOOR HANDLE  
(x1)

ENSURE CORRECT ORIENTATION  
OF DOOR HANDLE AS SHOWN.

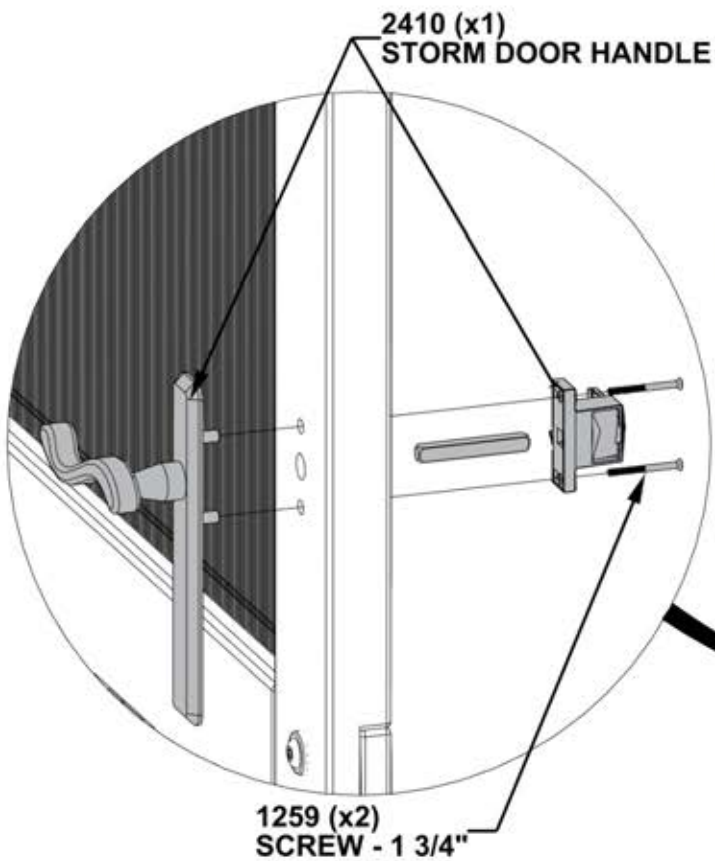

**USE SCREWDRIVER. DO  
NOT OVERTIGHTEN.**

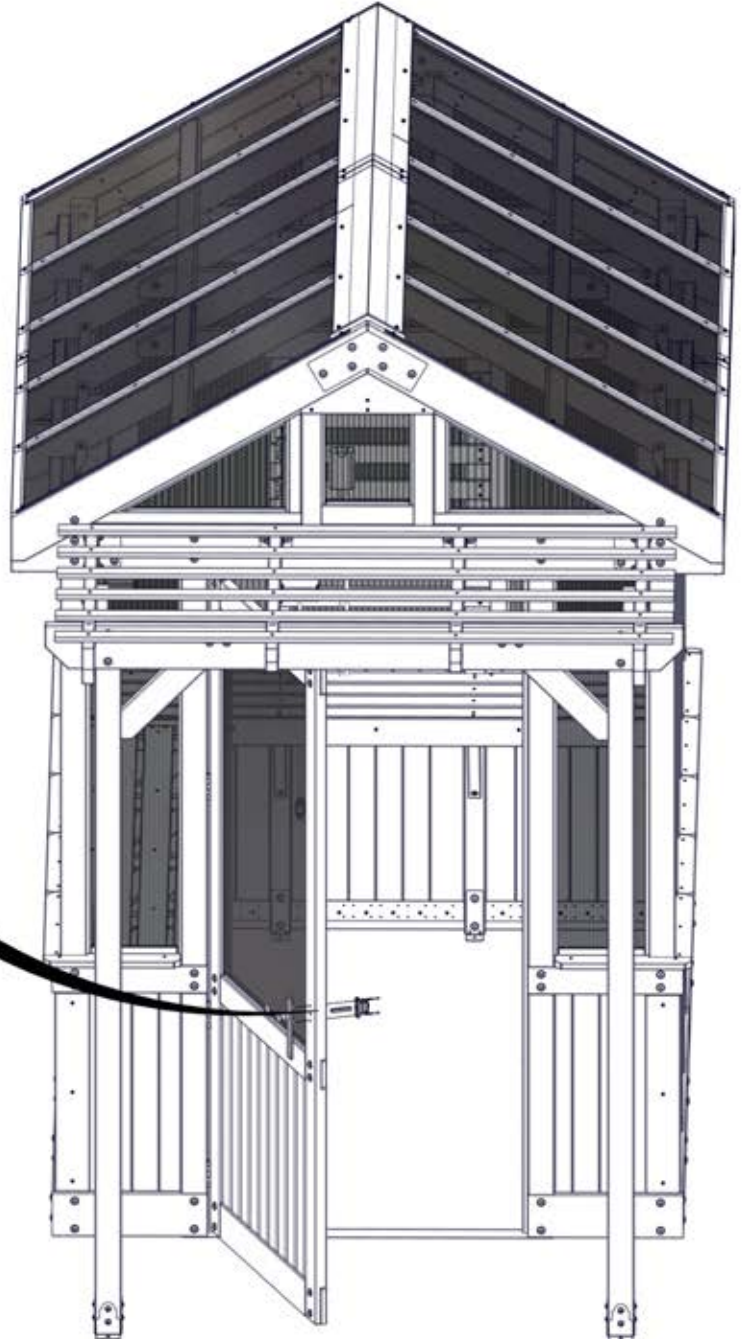

# STEP 126 - DOOR ASSEMBLY

QTY	PART NUMBER	DESCRIPTION
2	H101260	SCREW PRH 8x1 1/4 BLK



A4M02410 STORM DOOR HANDLE LATCH  
(x1)

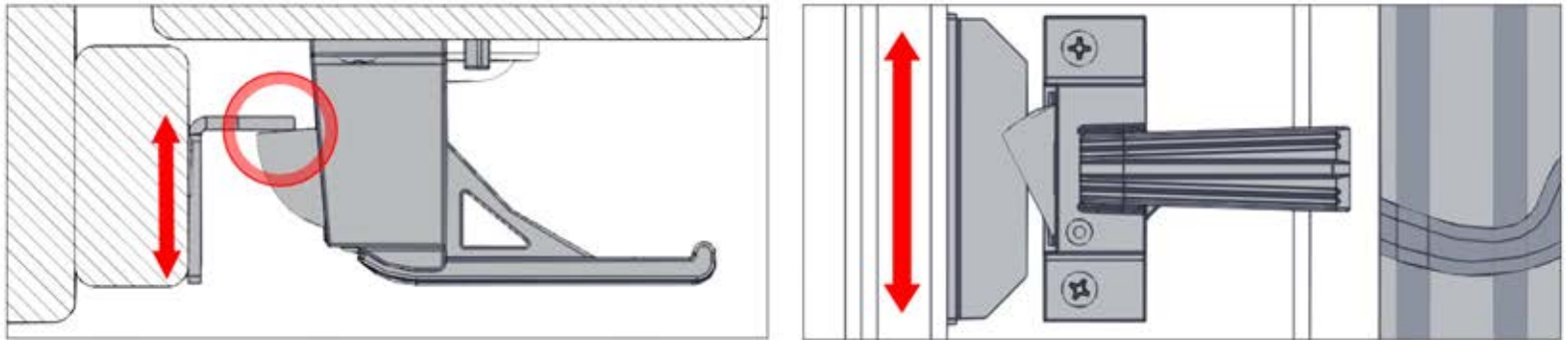

**WITH THE DOOR SHUT, POSITION THE DOOR LATCH AS SHOWN. ADJUST FRONT TO BACK TO ENSURE THE LATCH MAKES CONTACT AS SHOWN. ADJUST UP AND DOWN TO ENSURE THE LATCH IS CENTERED WITH THE HANDLE AS SHOWN. MARK THE SLOTTED HOLE LOCATIONS AND PRE-DRILL WITH AN 1/8" [3mm] DRILL BIT.**

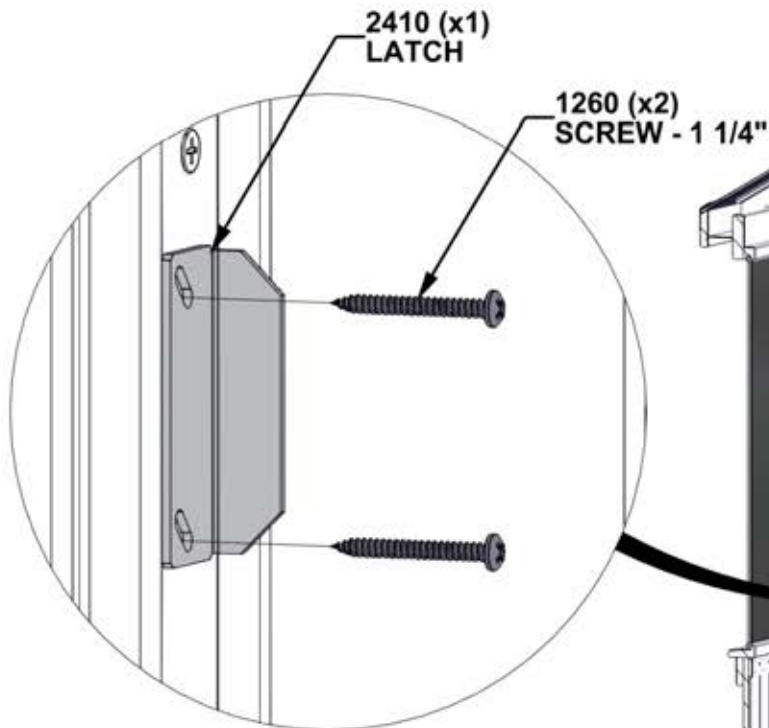

ATTACH USING PILOT HOLES.

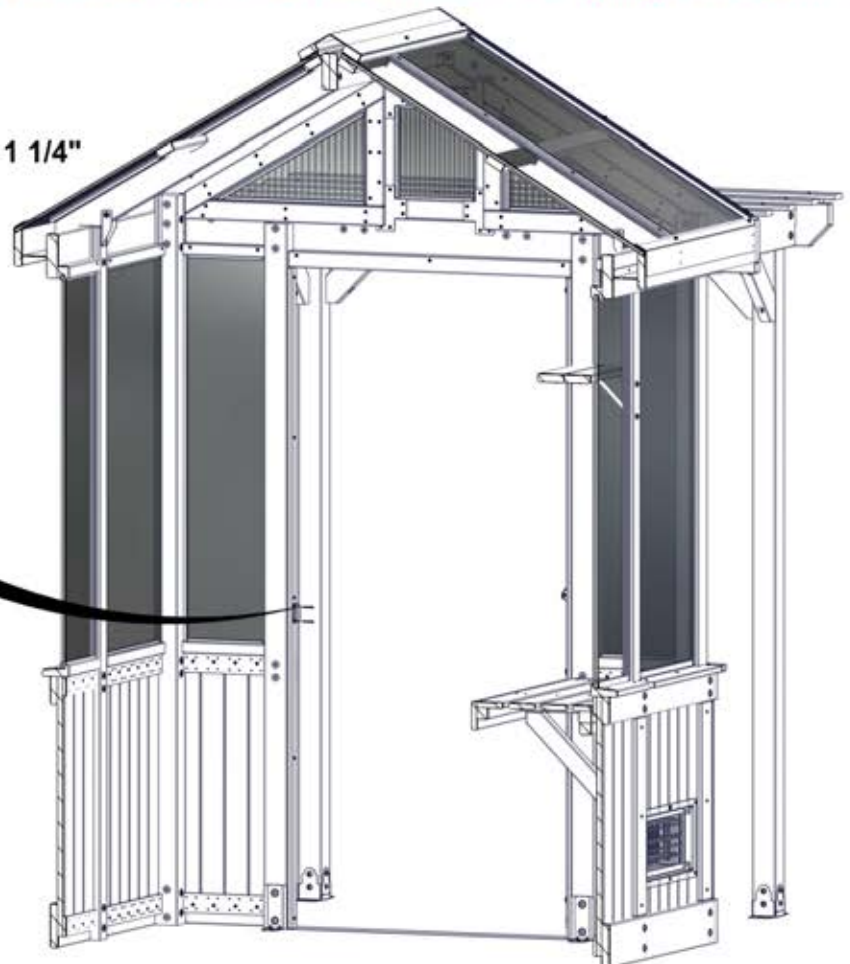

ONLY FRONT OF GREENHOUSE SHOWN FOR DETAIL.

# STEP 127 - DOOR ASSEMBLY

QTY	PART NUMBER	DESCRIPTION
5	H100202	SCREW PWH 8x5/8 BLK



A4M02532 DOOR SWEEP  
(x1)

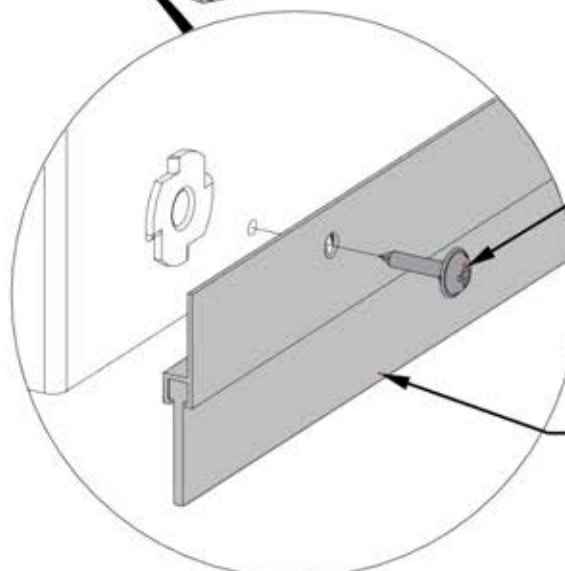
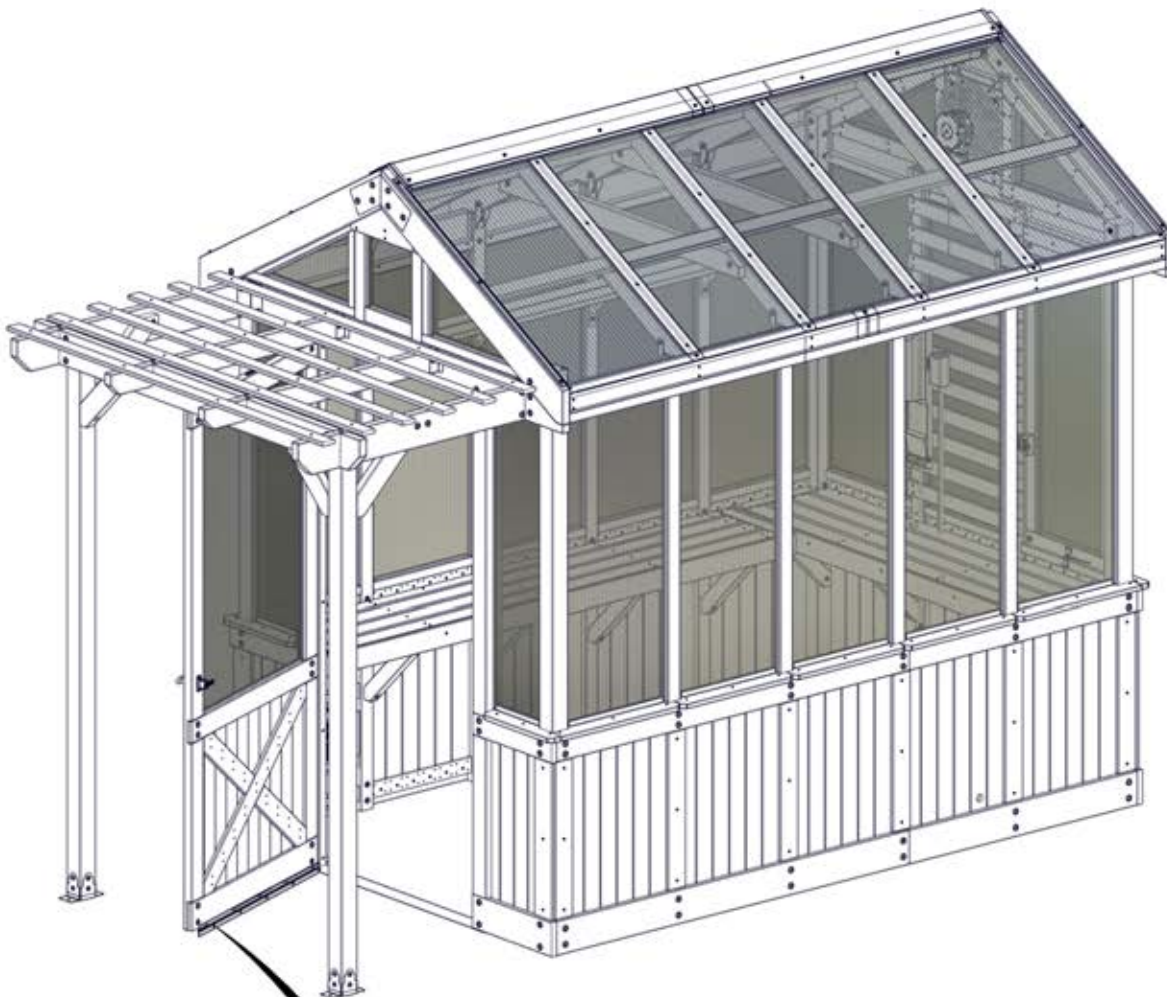

202 (x5)  
SCREW - 5/8"

ATTACH DOOR SWEEP USING PILOT HOLES IN DOOR ASSEMBLY AS SHOWN.

2532 (x1)  
DOOR SWEEP

# STEP 128 - DOOR ASSEMBLY

QTY	PART NUMBER	DESCRIPTION
4	H100392	SCREW PWH 8x3/4 BLK



A4M02411 DOOR PROTECTOR CHAIN  
(x1)

ATTACH DOOR CHAIN IN APROXIMATE LOCATION AS SHOWN.

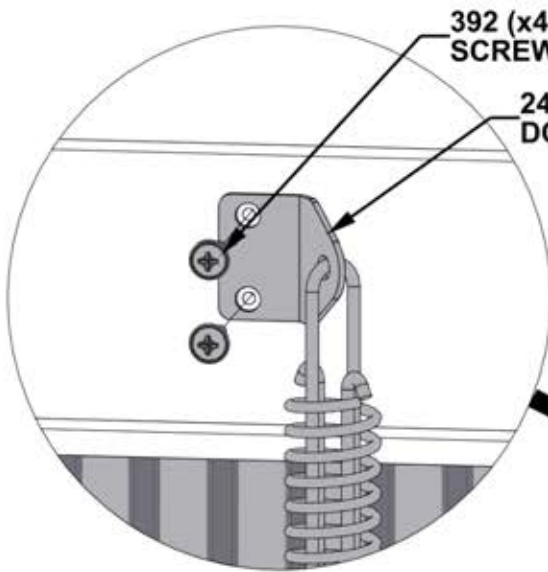
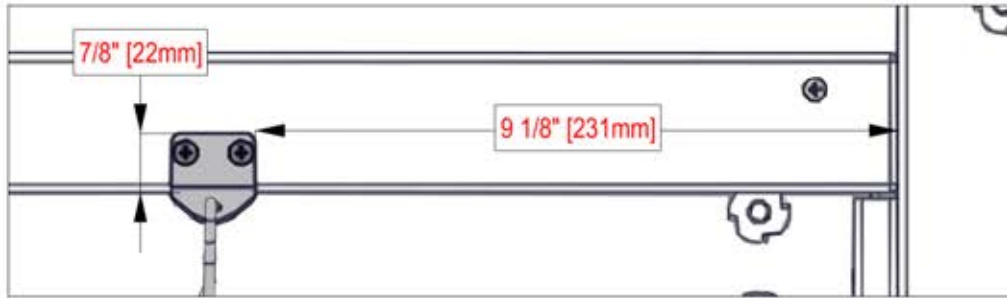

392 (x4)  
SCREW - 3/4"

2411 (x1)  
DOOR PROTECTOR CHAIN

ATTACH SPRING SIDE  
BRACKET TO DOOR USING  
PILOT HOLES AS SHOWN.

ONCE DOOR CHAIN IS  
ATTACHED, ADJUST CHAIN  
LENGTH TO PREVENT  
DOOR FROM CONTACTING  
PERGOLA ANGLE BRACE.

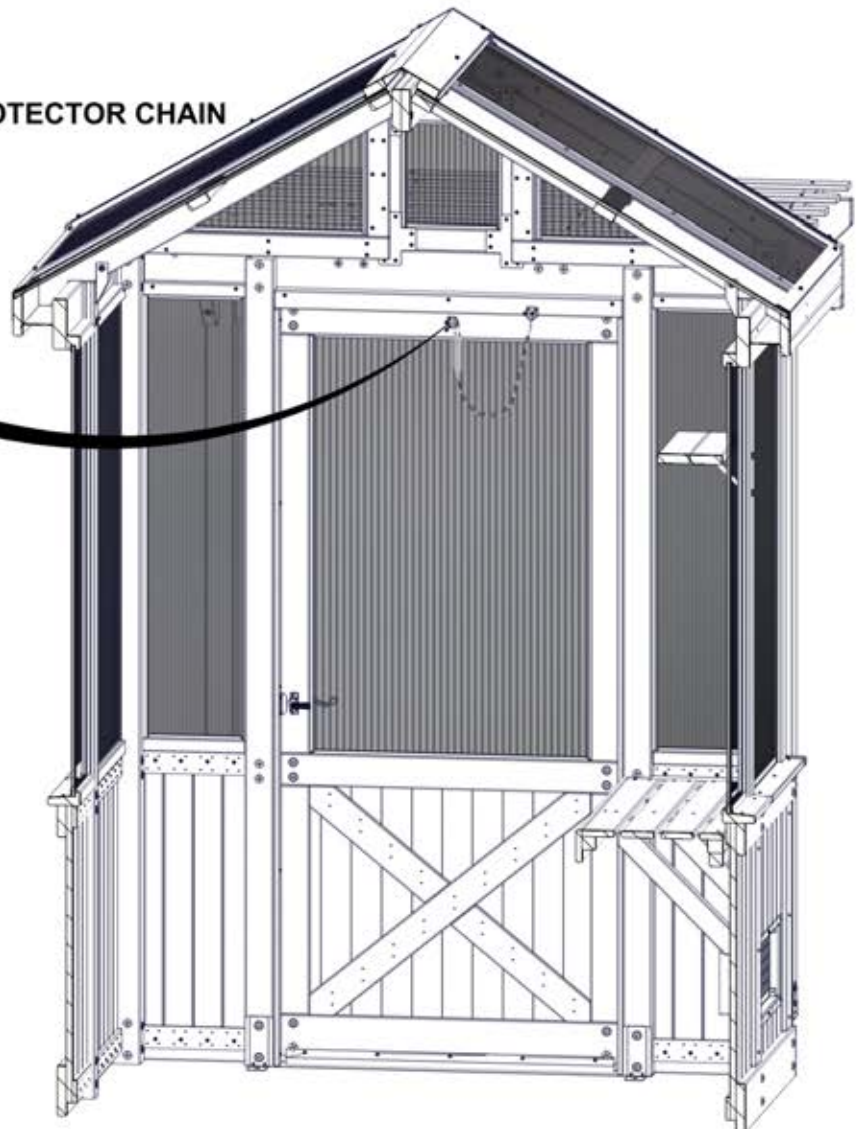

ONLY FRONT OF GREENHOUSE SHOWN FOR DETAIL.

# STEP 129 - BACK WALL ASSEMBLY

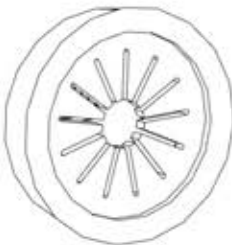

A6P00692 CORD GROMMET  
(x1)

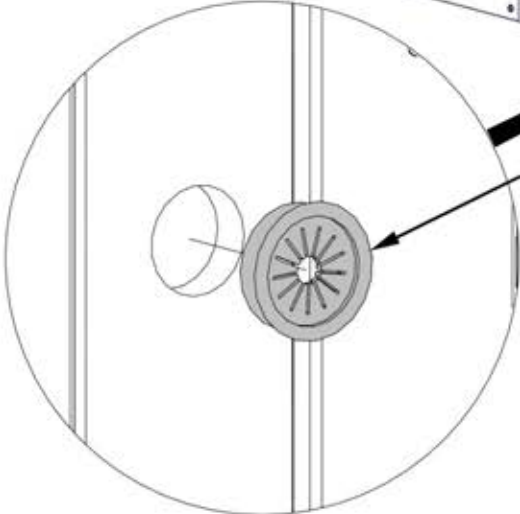

0692 (x1)  
CORD GROMMET

# STEP 130 - ROOF ASSEMBLY



A4M01591 HOOK  
(x4)

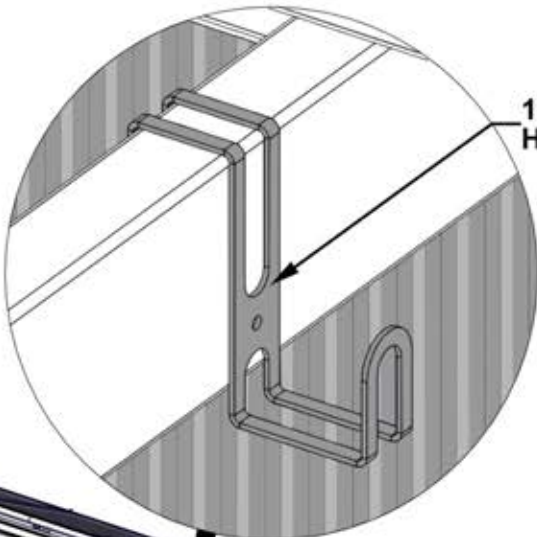

1591 (x4)  
HOOK

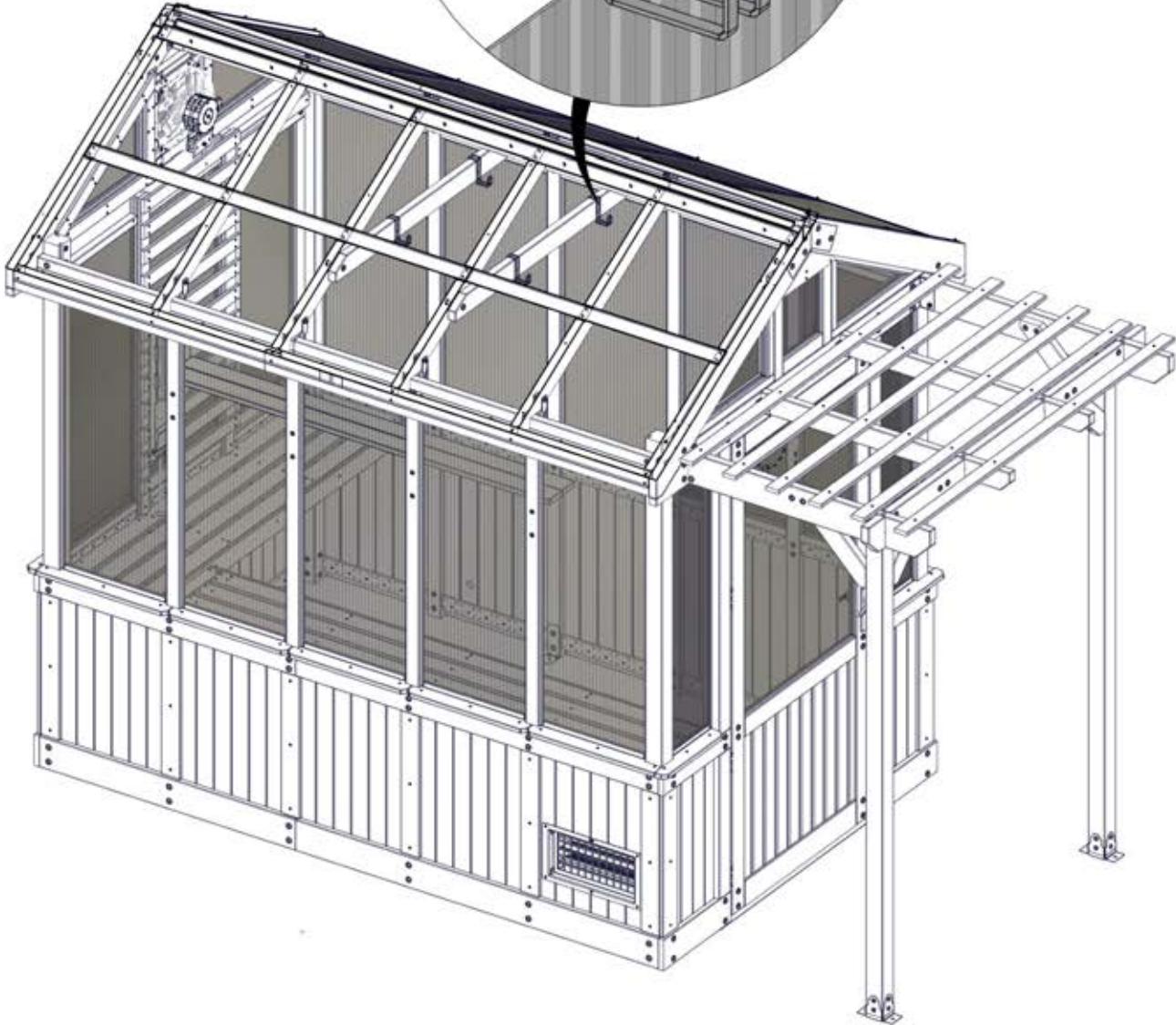

# STEP 131 - WATER LINE ASSEMBLY

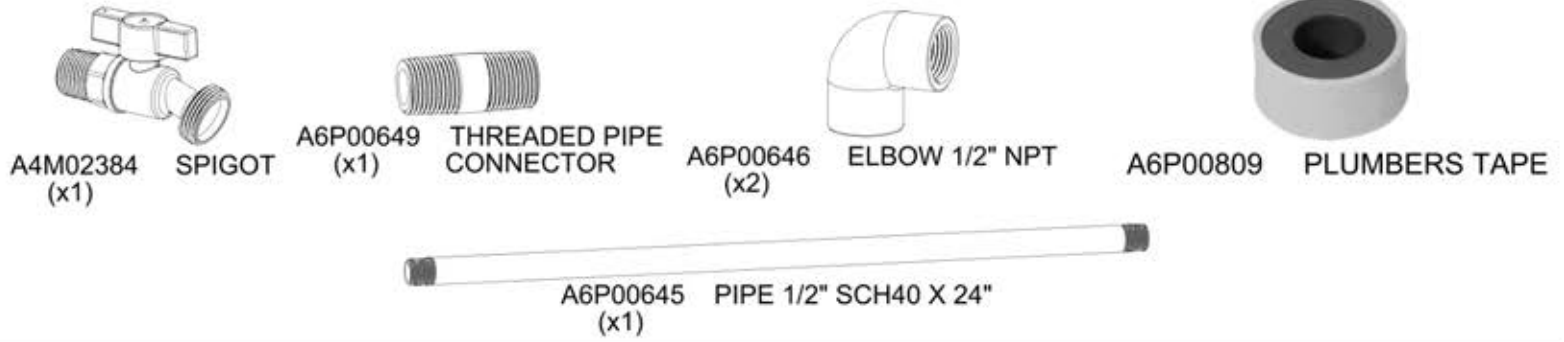

- USE PLUMBERS TAPE AND WRAP THREADS OF MALE FITTINGS.
- FASTEN FITTINGS TO FORM THE COMPLETED WATER LINE ASSEMBLY BELOW.

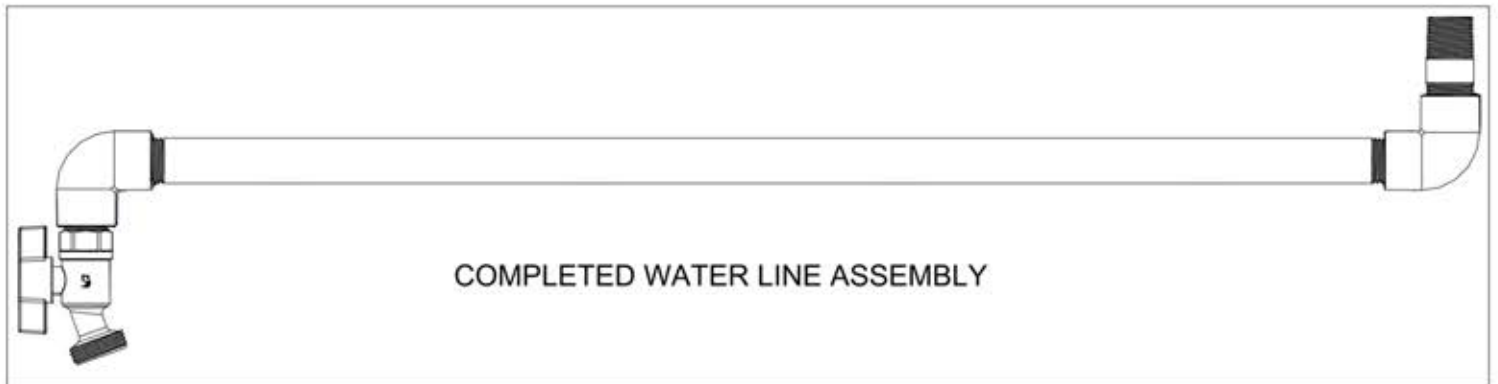
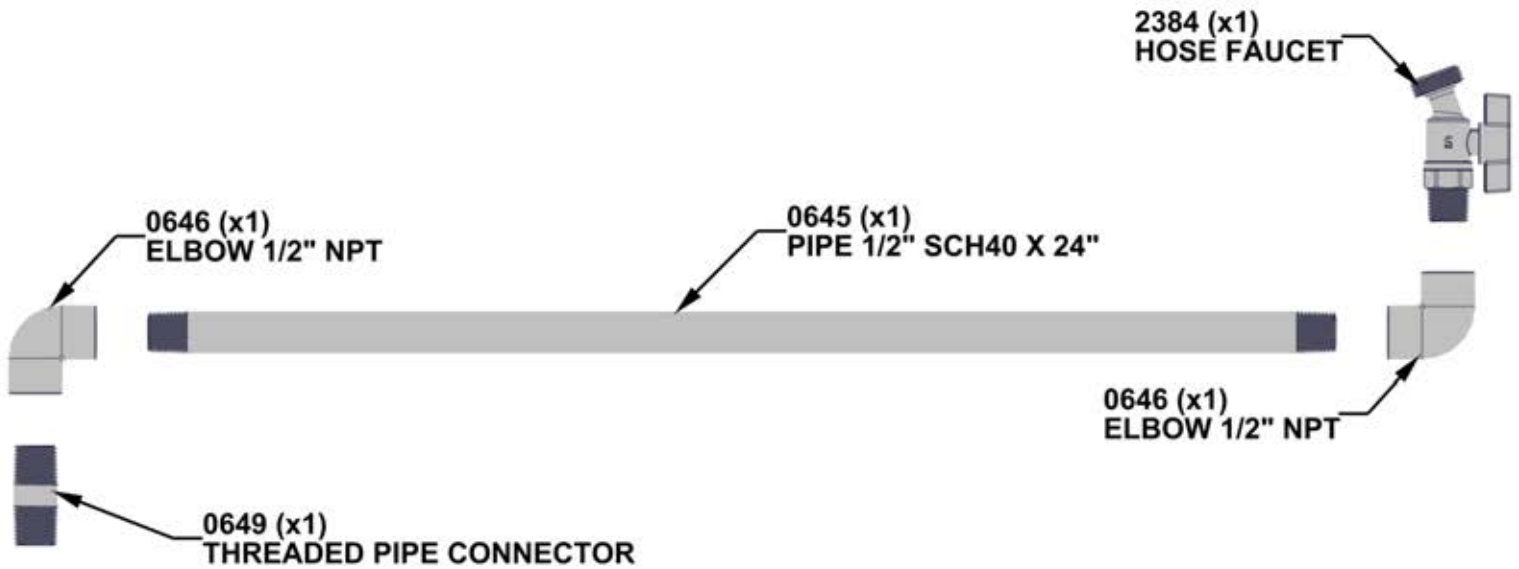

# STEP 132 - WATER LINE ASSEMBLY

QTY	PART NUMBER	DESCRIPTION
4	H100380	SCREW PFH 8x1 1/8 BLK



N10 SPIGOT BOARD - W4L20114  
(x1) 5/8"x2 3/8"x20 11/16" (16x60x526)

- USE DIMENSIONS SHOWN TO LOCATE SPIGOT BOARD.
- USE THE SPIGOT BOARD AS A GUIDE TO DRILL PILOT HOLES WITH AN 1/8" [3mm] DRILL BIT.

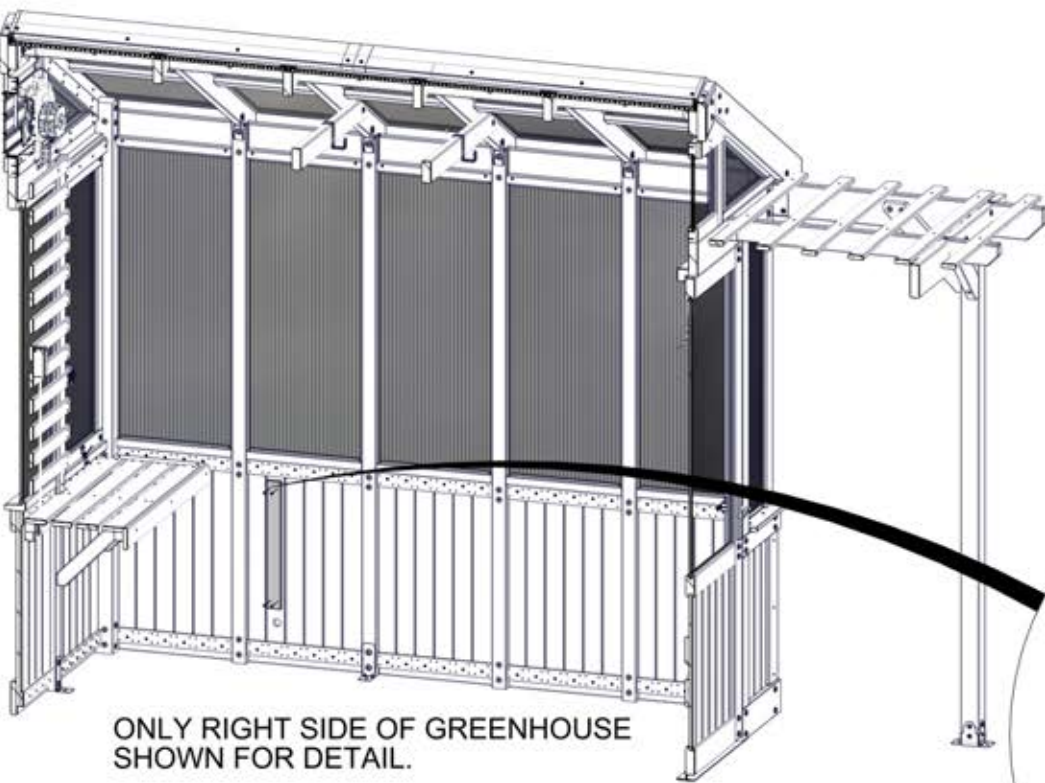
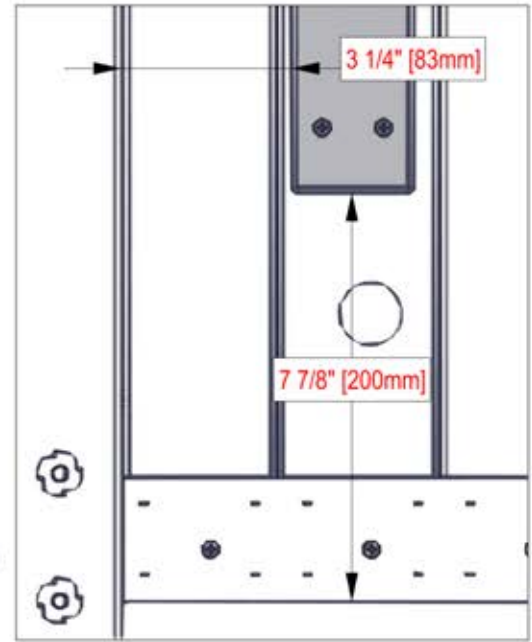

ONLY RIGHT SIDE OF GREENHOUSE SHOWN FOR DETAIL.

380 (x4)  
SCREW - 1 1/8"

N10 (x1)  
SPIGOT BOARD

# STEP 133 - WATER LINE ASSEMBLY

QTY	PART NUMBER	DESCRIPTION
2	H100385	SCREW PFH 8x1 BLK

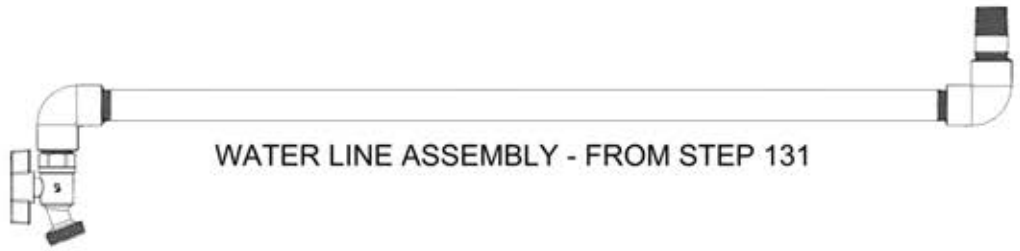
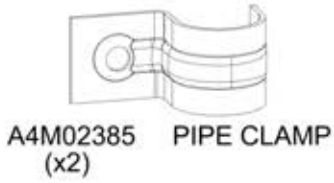

- INSERT WATER LINE ASSEMBLY THROUGH HOLE IN WALL PANEL.
- SECURE WATER LINE TO BOARD FROM PREVIOUS STEP WITH PIPE CLAMPS.
- PRE-DRILL WITH AN 1/8" [3mm] DRILL BIT WITH CLAMPS LINED UP IN POSITION.
- FASTEN CLAMPS FLUSH TO OUTSIDE CORNERS AS SHOWN.

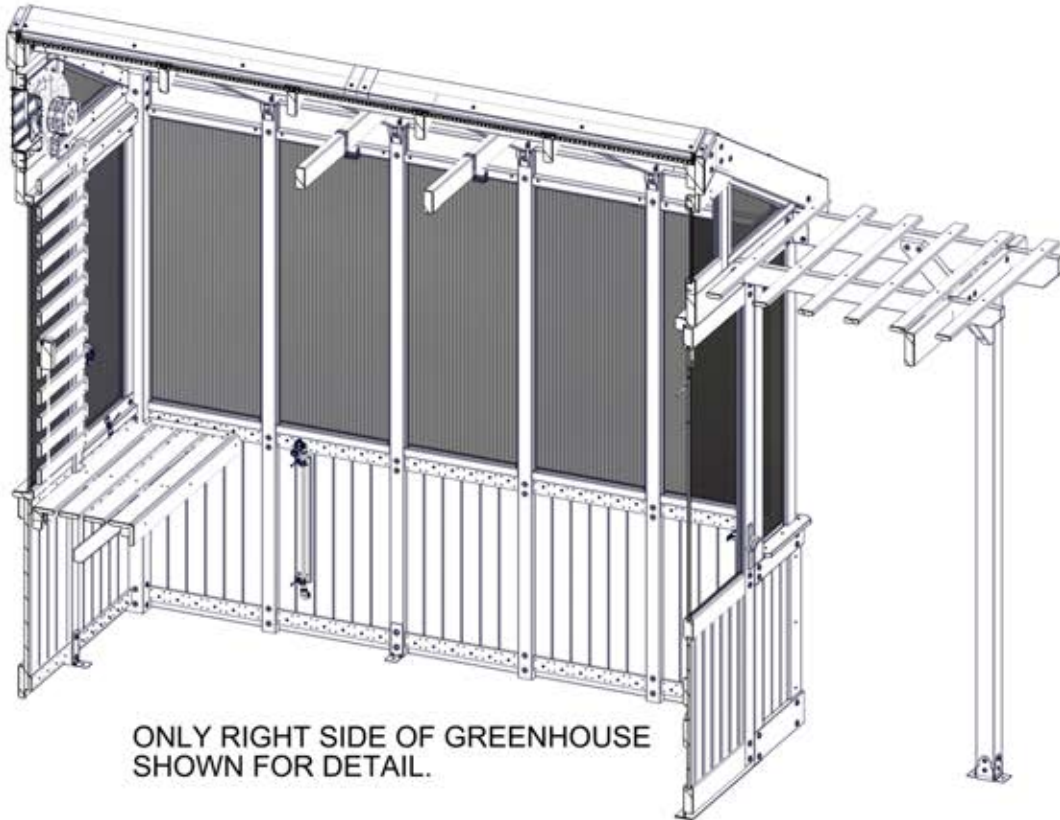
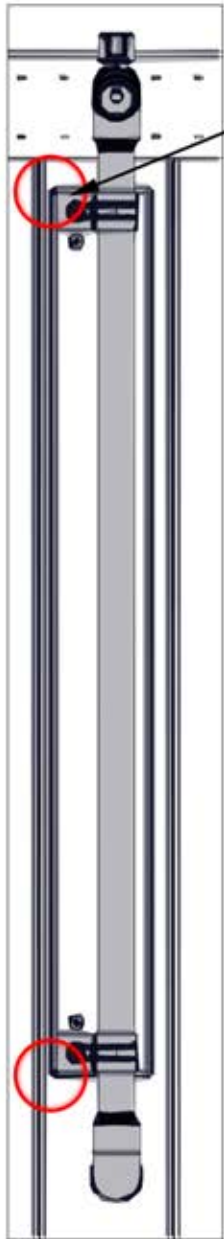

2385 (x2)  
PIPE CLAMP

385 (x2)  
SCREW - 1"

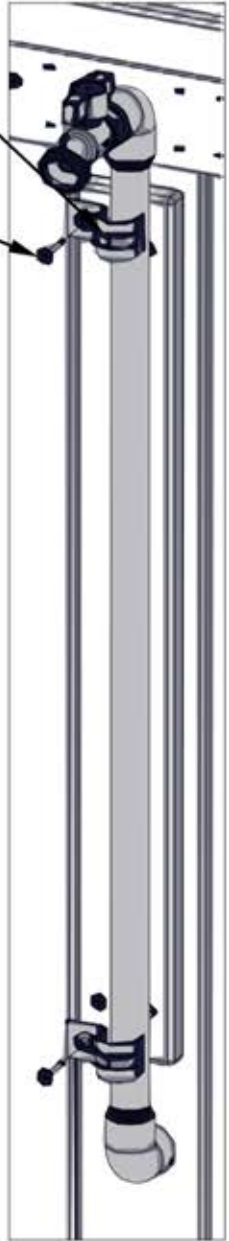

# STEP 134 - WATER LINE ASSEMBLY



A6P00648 THREADED HOSE FITTING  
(x1)



A6P00577 RUBBER GROMMET  
(x1)



A6P00809 PLUMBERS TAPE

- PUSH RUBBER GROMMET IN HOLE AROUND THE WATER LINE ASSEMBLY FROM PREVIOUS STEPS.
- USE PLUMBERS TAPE AND WRAP THREADS OF MALE FITTINGS.
- FASTEN THREADED HOSE FITTING.

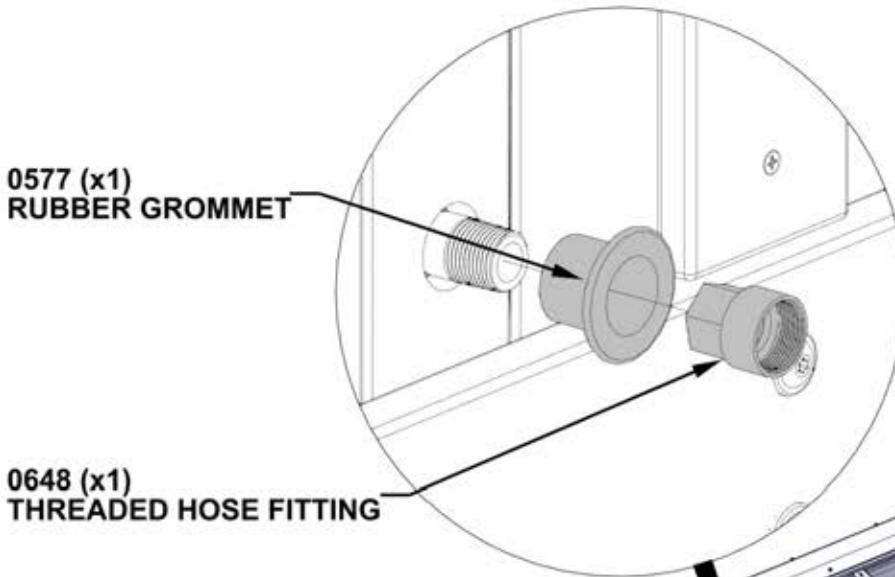

0577 (x1)  
RUBBER GROMMET

0648 (x1)  
THREADED HOSE FITTING

**INSTALL RUBBER GROMMET  
BEFORE THREADED HOSE FITTING.**

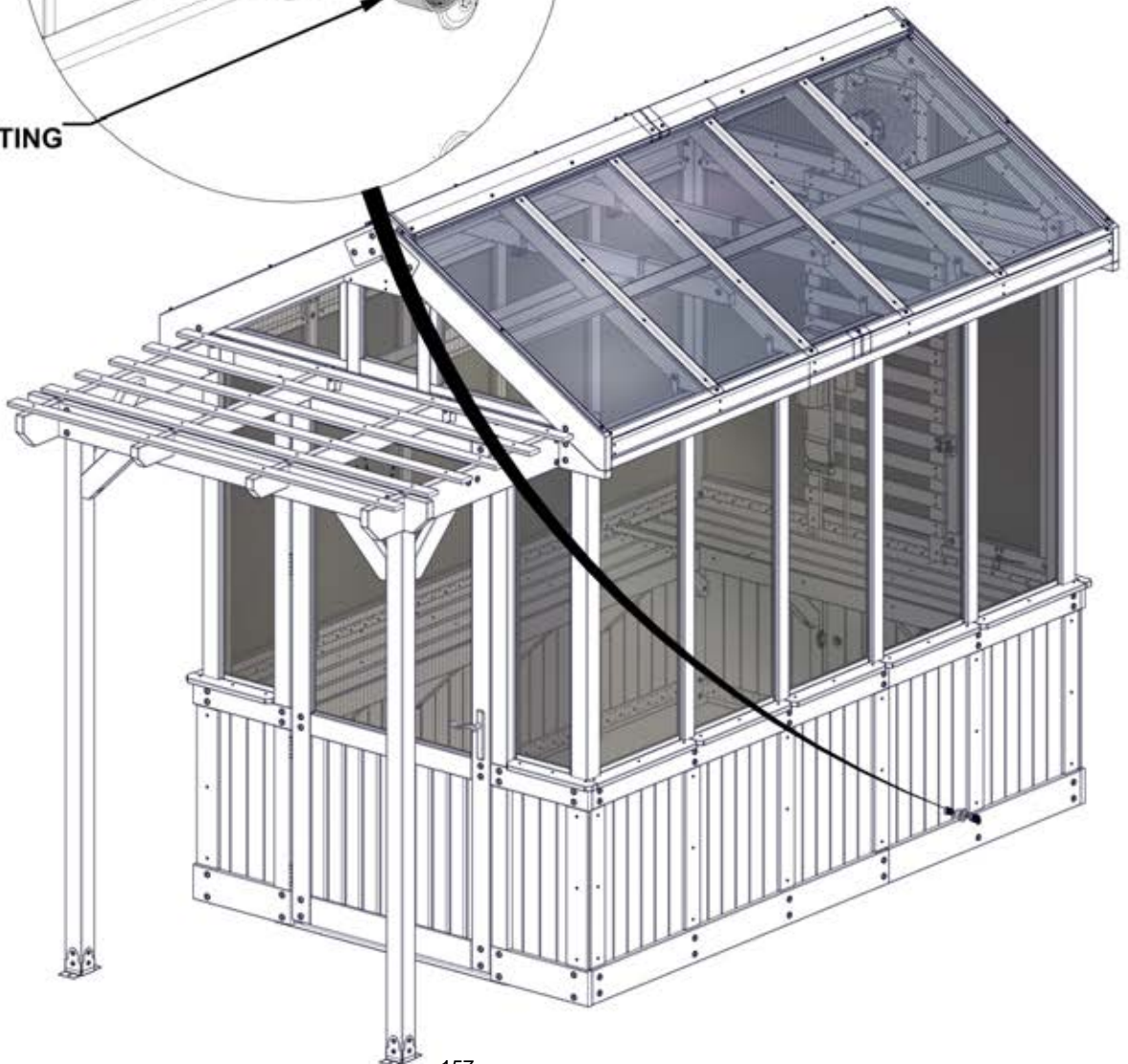

# STEP 135 - ANCHORING TO CONCRETE

QTY	PART NUMBER	DESCRIPTION
10	H101165	CONCRETE ANCHOR 3/8x3" BLK

**IF GREENHOUSE IS NOT ON A CONCRETE SURFACE, SEE STEP 136 FOR ANCHORING STRUCTURE.**

**IT IS RECOMMENDED TO ANCHOR YOUR GREENHOUSE INTO CONCRETE PAD OR POSTS.**

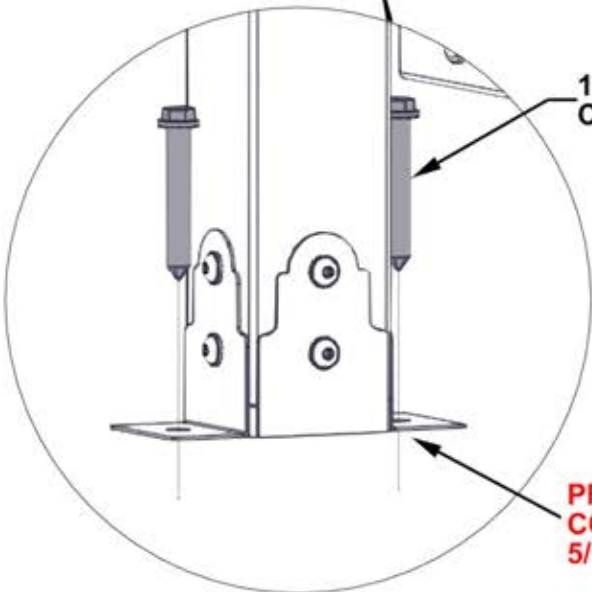
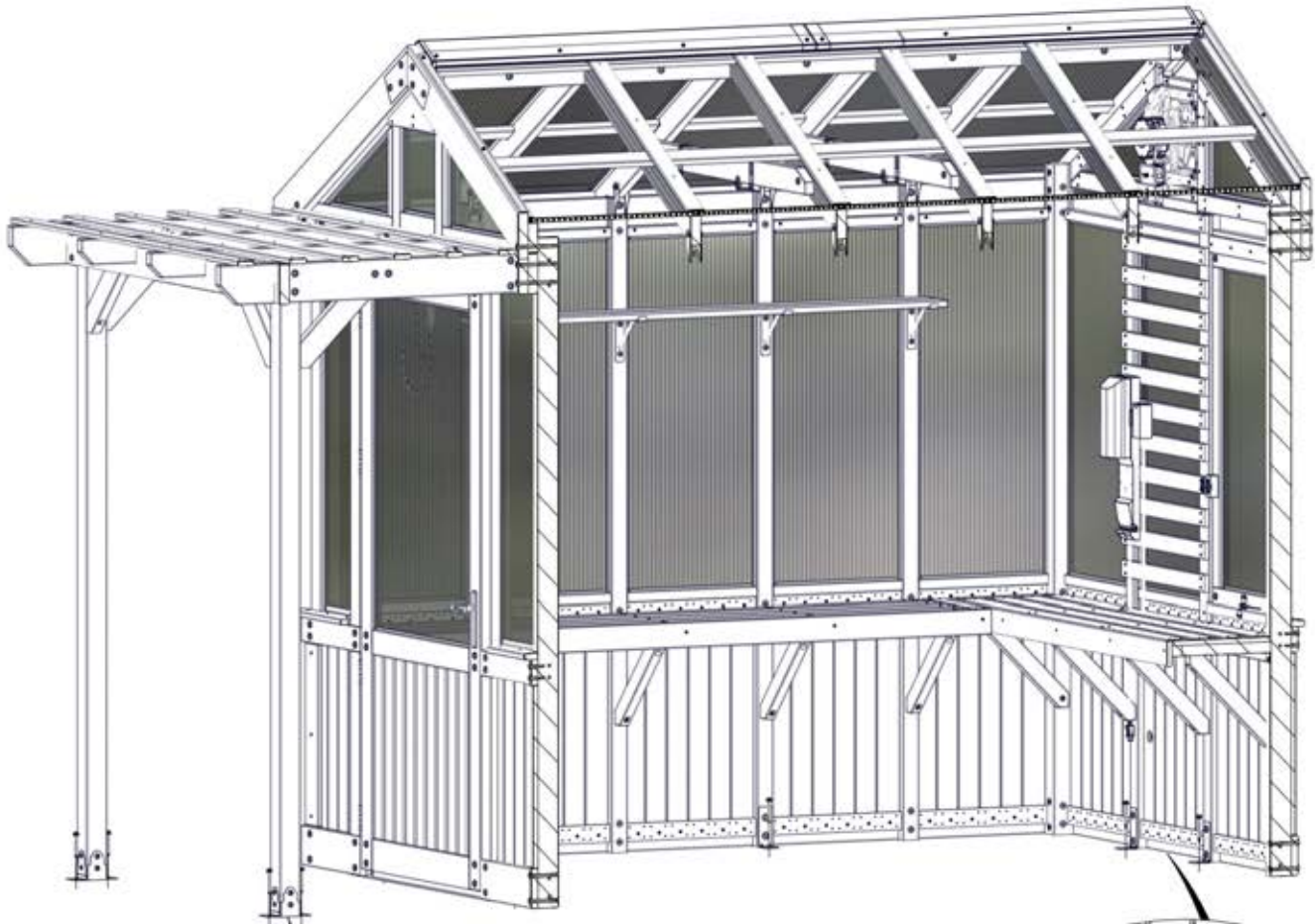

**1165 (x10)  
CONCRETE ANCHOR-3"**

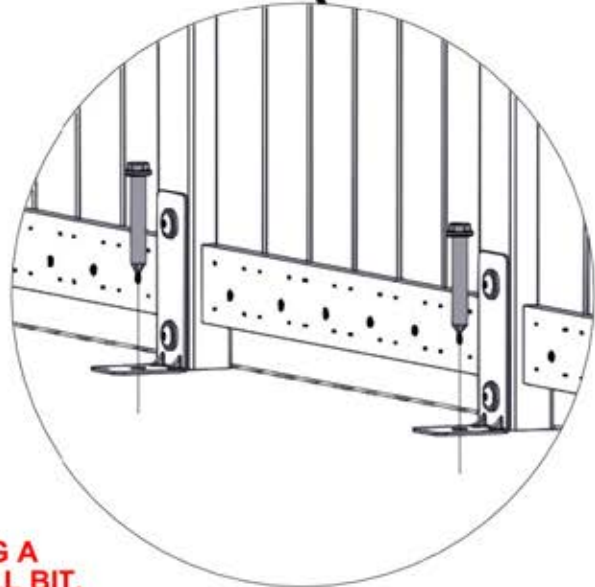

**PRE-DRILL HOLES FOR  
CONCRETE ANCHORS USING A  
5/16" [8mm] CONCRETE DRILL BIT.**

# STEP 136 - ANCHORING IN GROUND



**IF GREENHOUSE IS ON A CONCRETE SURFACE, SEE STEP 135 FOR ANCHORING STRUCTURE.**

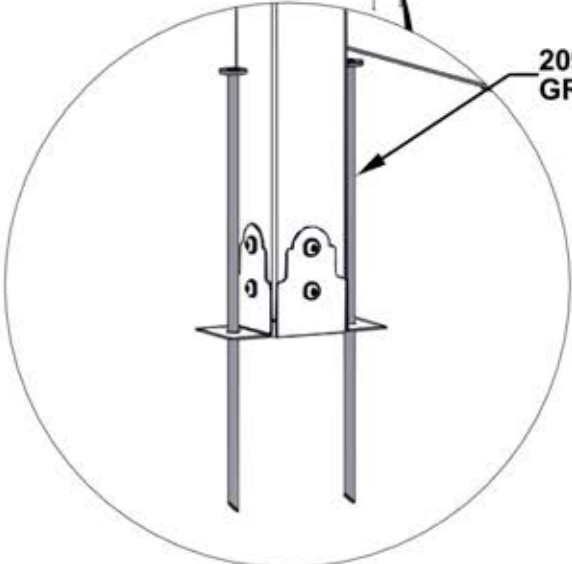

# STEP 137 - DOOR ASSEMBLY

QTY	PART NUMBER	DESCRIPTION
4	H100202	SCREW PWH 8x5/8 BLK

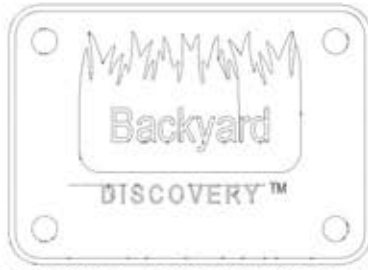

A4M02158 BYD ID TAG PATIO  
(x1)

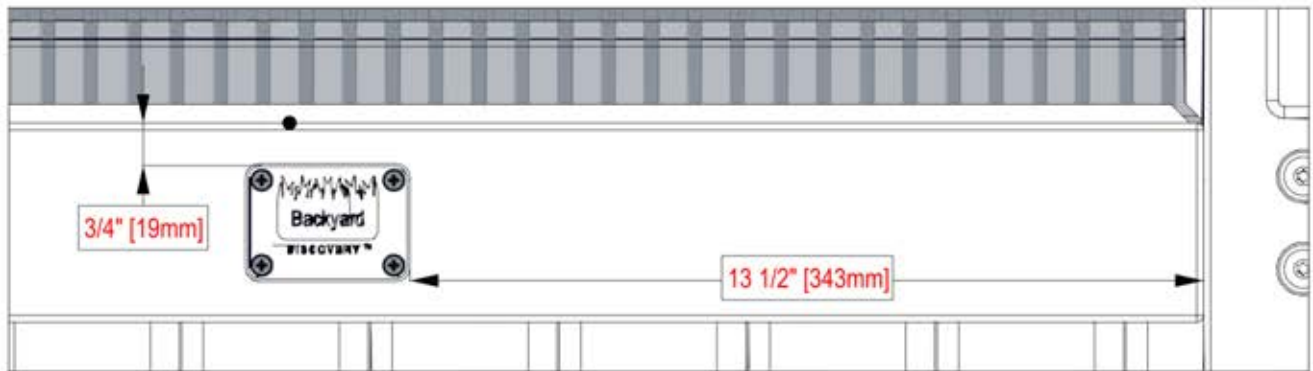

CENTER ID TAG ON BOARD WITH MEASUREMENTS GIVEN.

