

Item: HAMD1D

Assembly Instructions

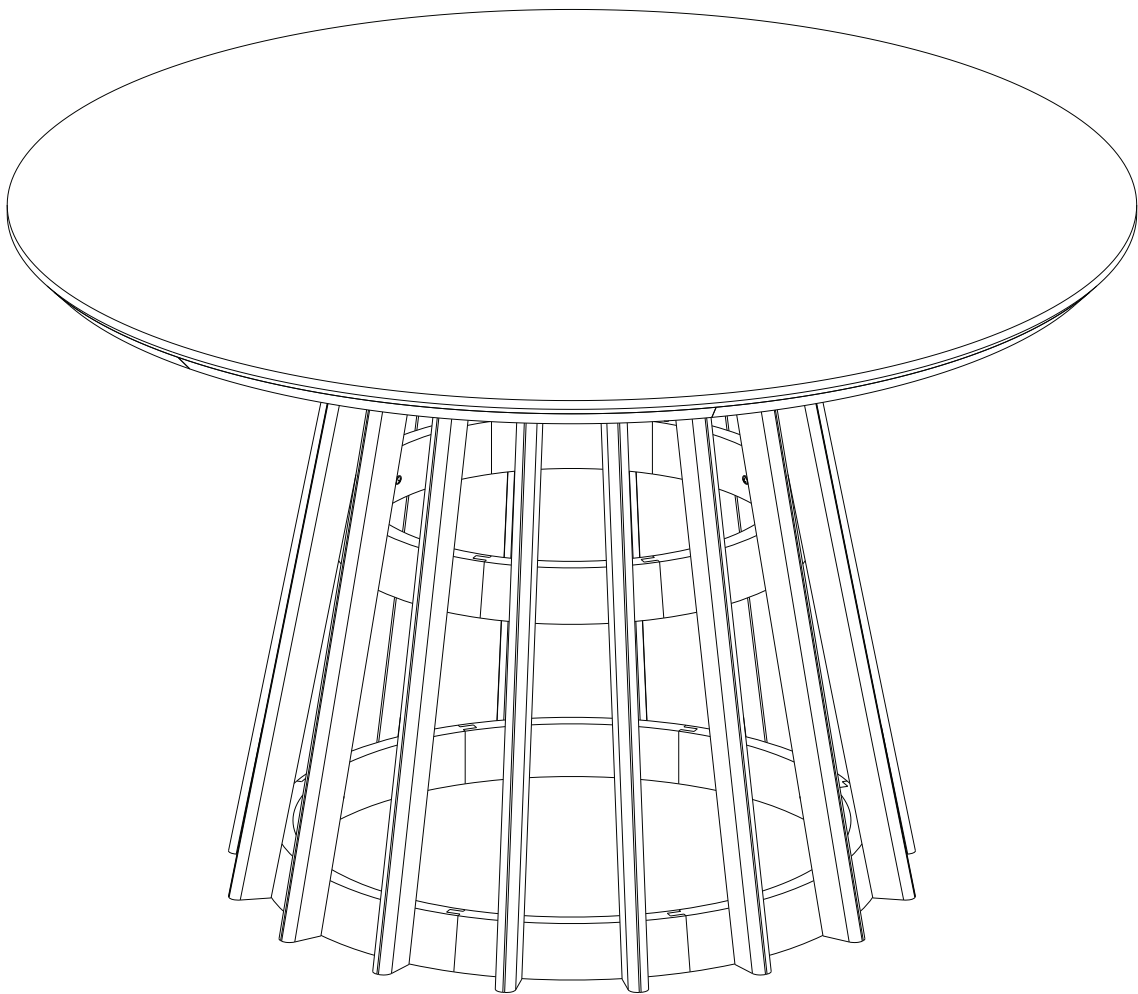

Please visit our website for the most current instructions, assembly tips, to report damage or request parts. www.walkeredison.com

Revised 08/23-V-1

General Assembly Guidelines

- I. Ensure that all parts and hardware are available before beginning assembly.
- II. Follow each step carefully to ensure the proper assembly of this product.
- III. Two people are recommended for ease in the assembly of this product.
- IV. The three main types of hardware used to assemble this product are wood dowels, screws and bolts.
- V. A Phillips head screwdriver and hammer is required for the assembly of this product.

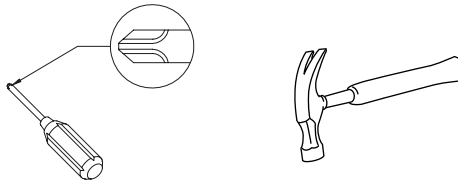

- V I. Power tools should not be used to assemble this product.

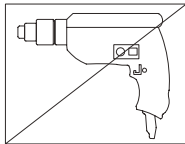



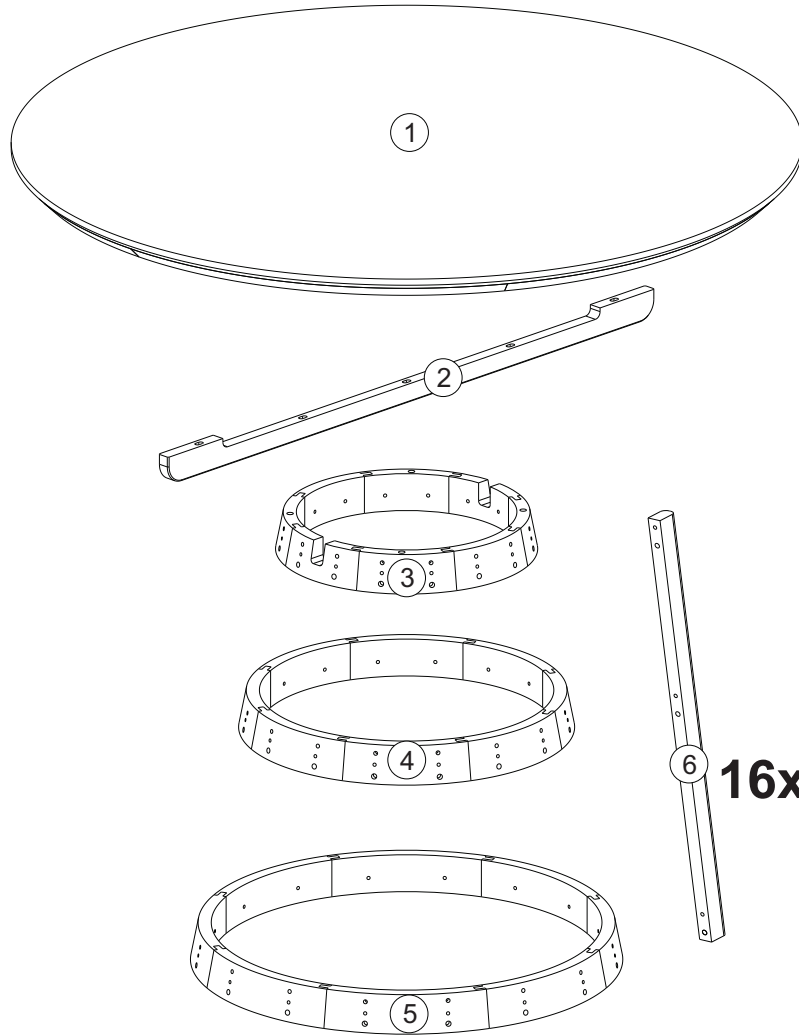



Parts List

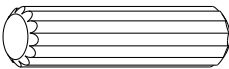
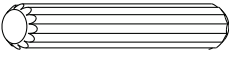

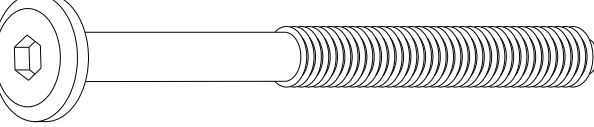
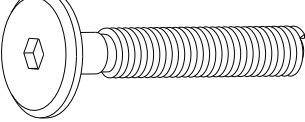
Part #	Description	Qty
1	Top panel	01 pc
2	Rail	01 pc
3	Upper base assembled	01 pc
4	Central base assembled	01 pc
5	Lower base assembled	01 pc
6	Vertical rail	16 pcs

Hardware List

A		ø8*30mm	Wooden dowel	48 pcs
B		ø6*30mm	Wooden dowel	48 pcs
C		ø4*40mm	Screw	48 pcs
D		ø1/4"*80mm	Screw	04 pcs
E		ø1/4"*40mm	Screw	05 pcs
F			Hex Key	01 pcs
G		12mm	Washer	05 pcs
H			Adesive Felt	04 pcs

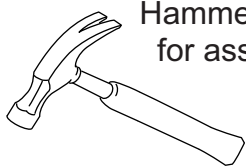

Hammer recommended
for assembly (not included)



Phillips head screwdriver required
for assembly (not included)

*The hardware quantities listed above are required for proper assembly.
Some extra hardware may also have been included.*

Step 1

Attention to the
dowel size:
ø6*30mm

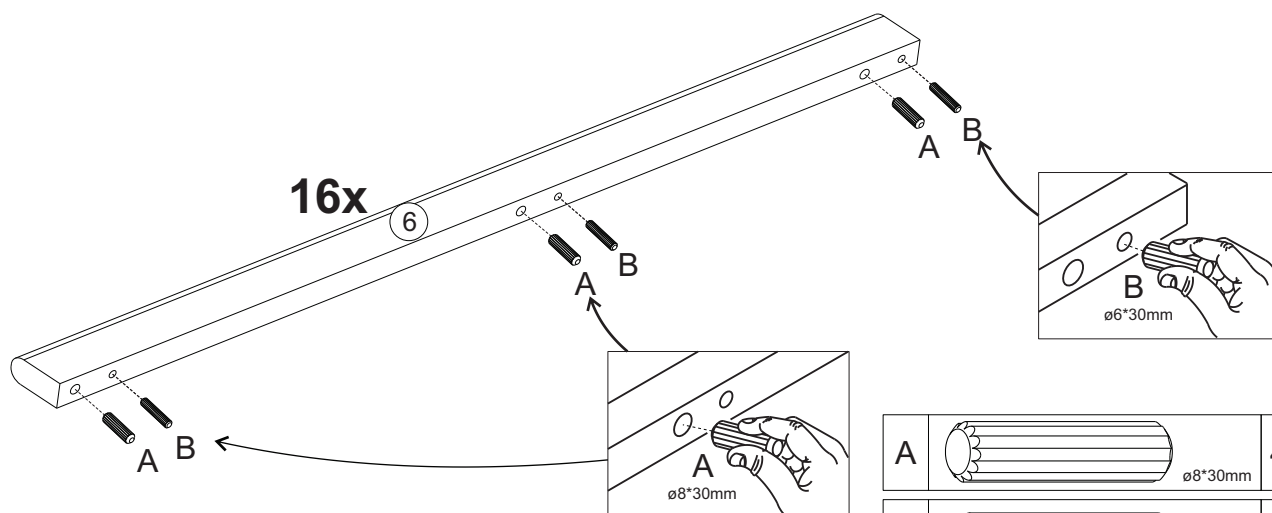
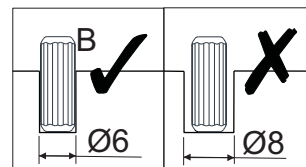

Insert wood dowel (A) and (B) into part 6.

A		ø8*30mm	48
B		ø6*30mm	48

Step 2

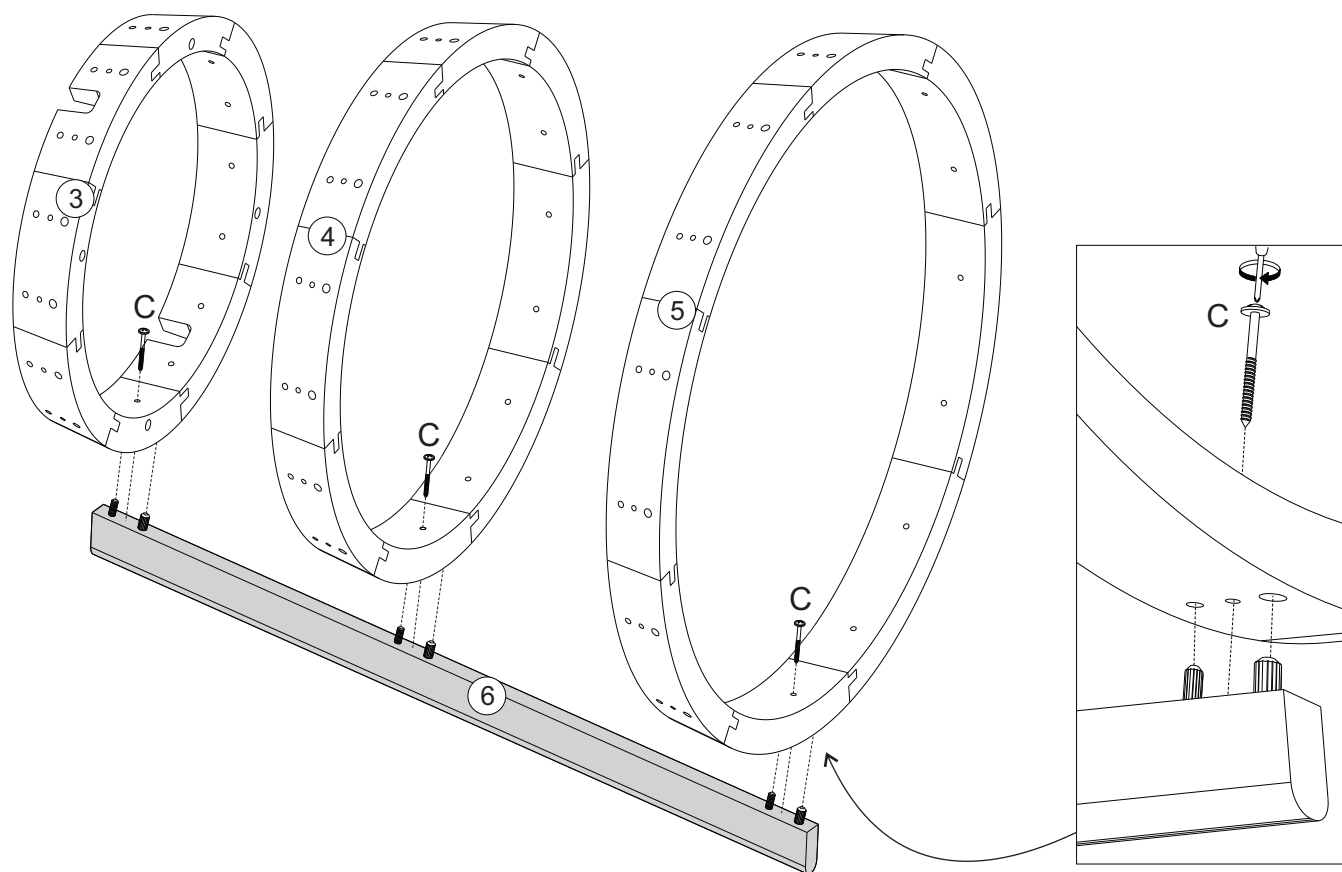

Fix one vertical rail 6 on the assembled bases 3, 4 and 5 with the screws (C), using Phillips Head Screwdriver.

C		ø4*40mm	03
---	--	---------	----

Step 3

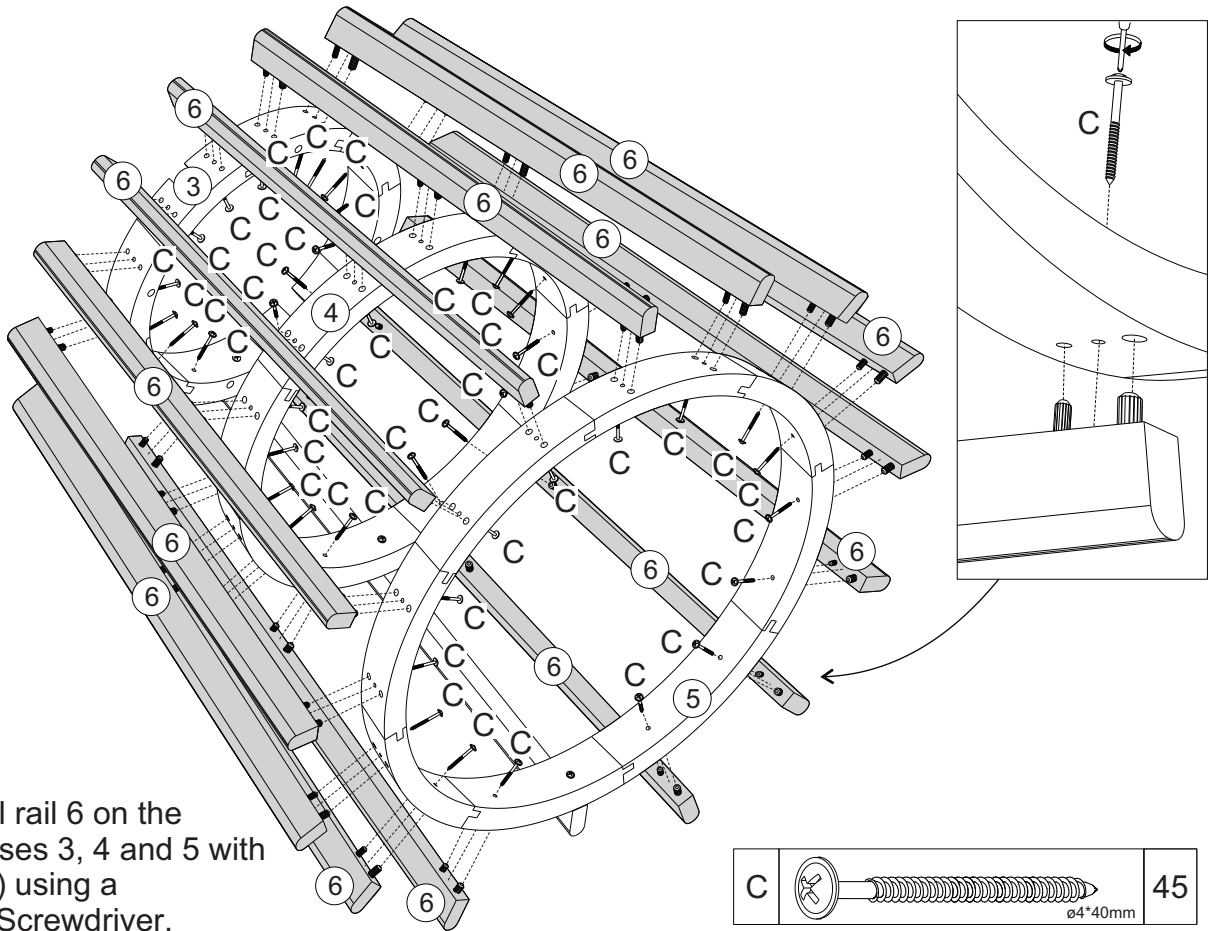

Fix the vertical rail 6 on the assembled bases 3, 4 and 5 with the screws (C) using a Phillips Head Screwdriver.

C		45
		ø4*40mm

Step 4

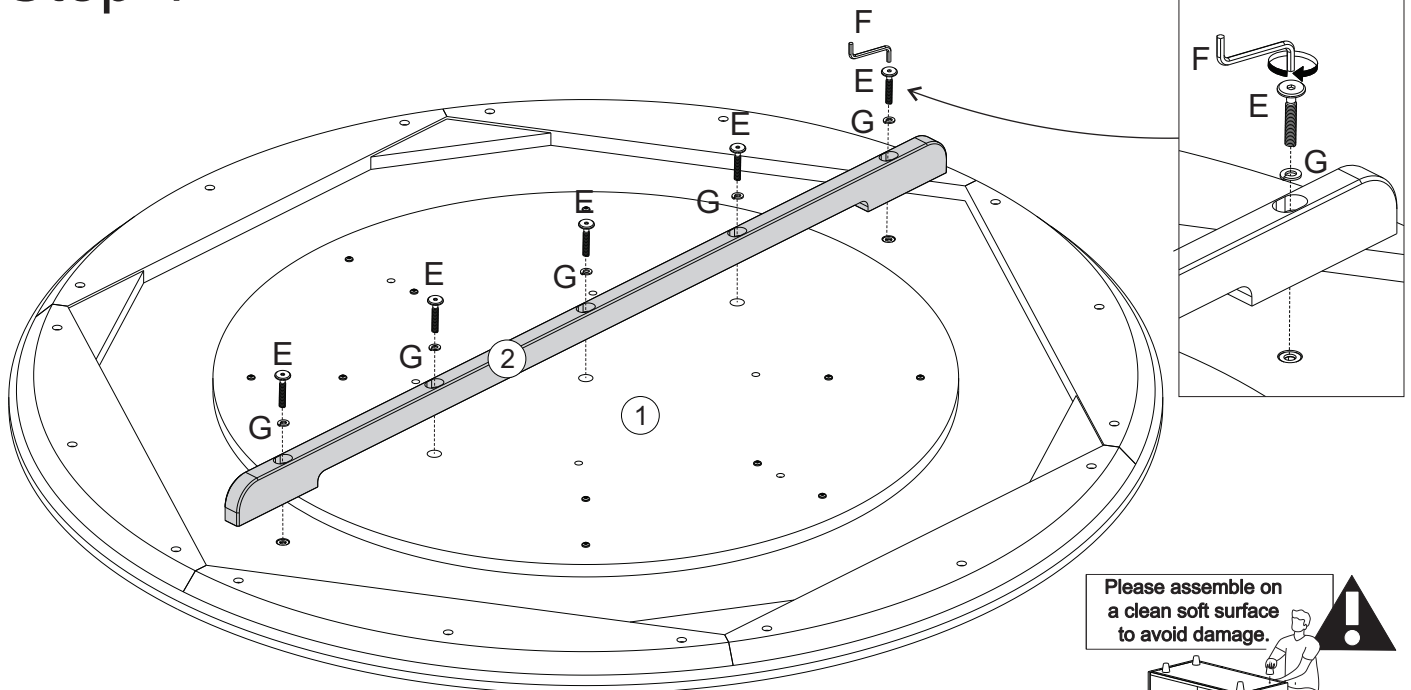

Please assemble on a clean soft surface to avoid damage.

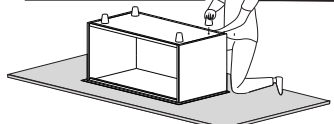

Fix the rails 2 on the table top 1 with the screws (E) and washer (G), using a hex key (F).

E		05
		ø1/4*40mm

F		01
		Hex key

G		05
		Washer

Step 5

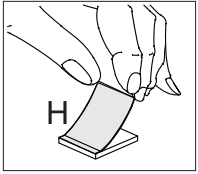

Before attaching remove the adhesive protection.

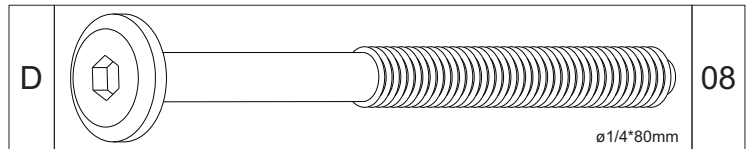
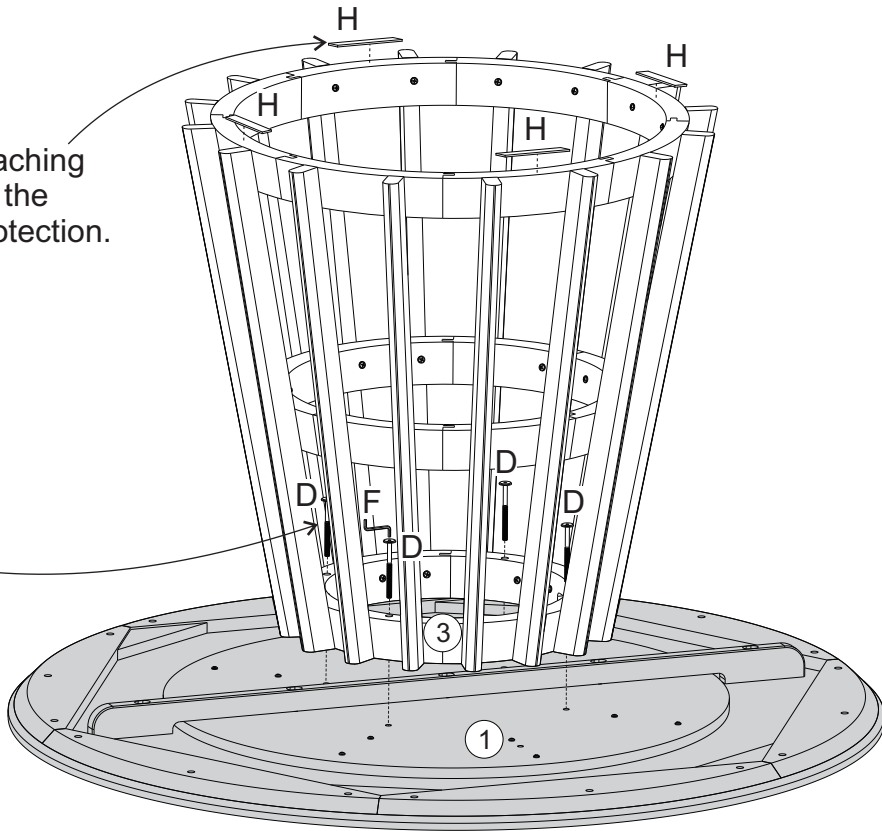
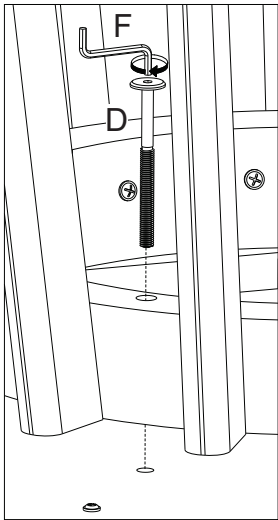

Fix the assembled base to the table top 1 with the screws (D), using a hex key (F) and attach adhesive felt (H).

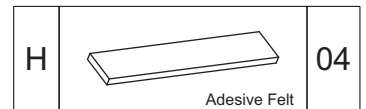
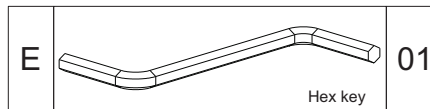

Step 6

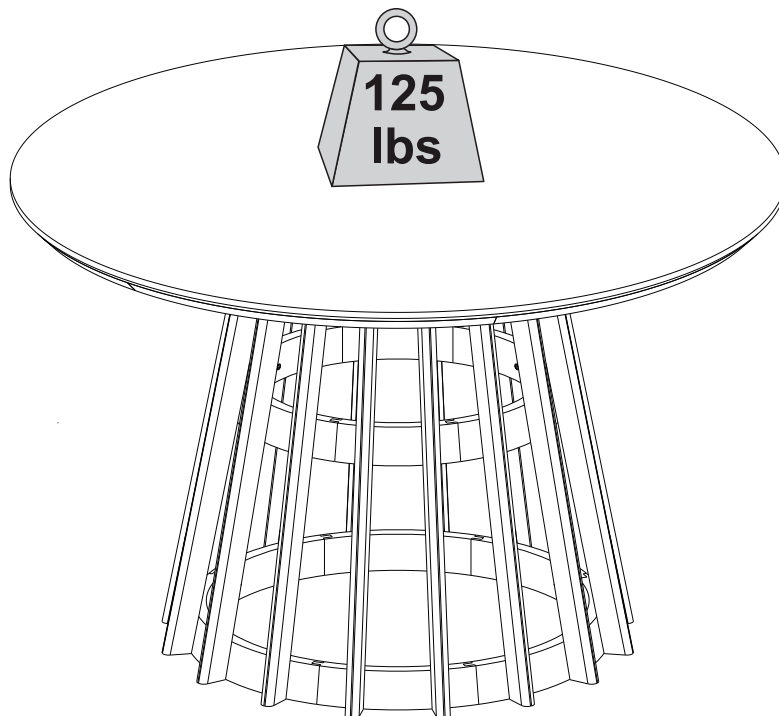

Distributed weight.

