



7-9168

Writing Desk

NO.	Hardware	List	Q'ty
A		Bolt (5/16" * 2-9/32")L	10
B		Lock Washer 5/16"Dia	10
C		Flat Washer 5/16" Dia	10

Note: Tools required screw driver

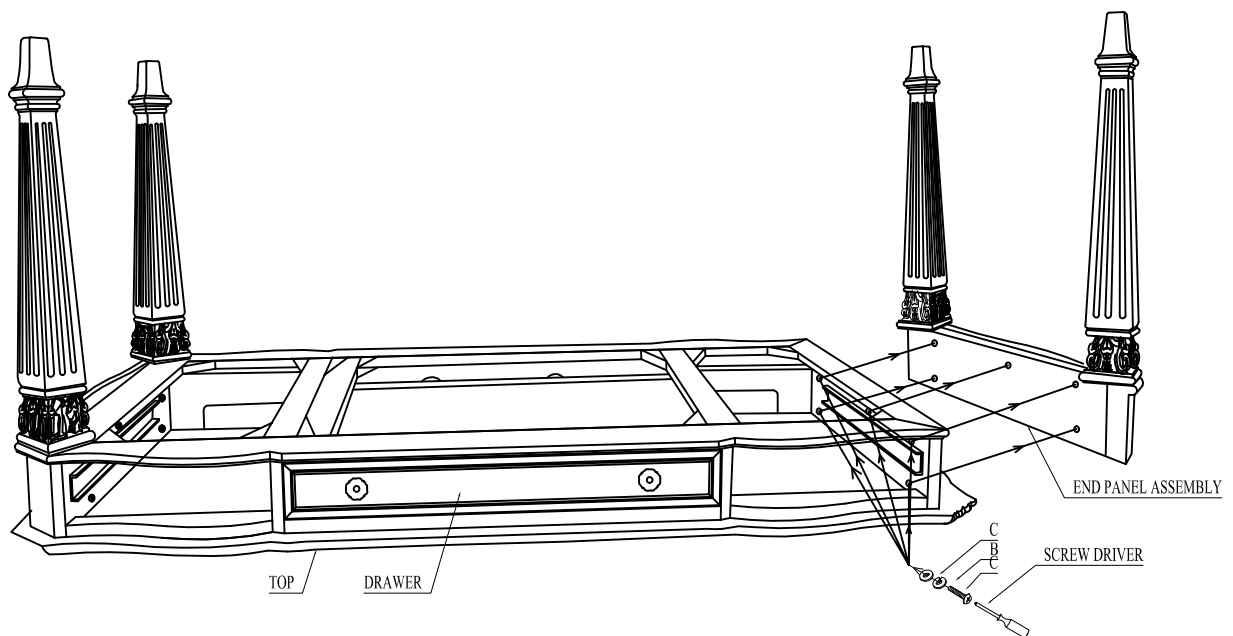
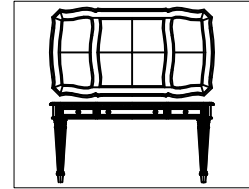

ASSEMBLY INSTRUCTION

- 1.PULL OUT DRAWERS ON SOFT MATERIAL TO PREVENT PULLING OFF AND SCRATCHING.
- 2.PLACE THE TOP UPSIDE DOWN ONTO A SOFT SURFACE TO PREVENT DAMAGE.
- 3.MATCH COLOR DOTS FOR CORRECT POSITION OF THE LEGS.
- 4.PLACE LOCK WASHER ON BOLT.
- 5.PLACE FLAT WASHER ON BOLT.
- 6.TIGHTEN THE BOLTS WITH WASHER.
- 7.CAREFULLY TURN THE UNIT UPRIGHT.
- 8.INSERT THE DRAWERS BACK.