

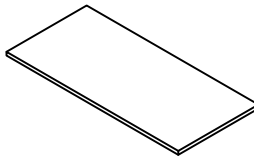

ASSEMBLY INSTRUCTION

3228-15C METAL & POPLAR WRITING DESK

A Top Panel	B Lower Panel	C Side Frame	D Crossbar
			
1PC	4PCS	4PCS	4PCS
E Screw 1/4"X1-3/8"XØ16	F Allen Wrench 1/4"	G Screw 1/4"X1/2"XØ16	
			
24PCS	1PC	8PCS	

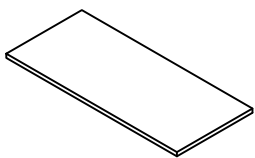
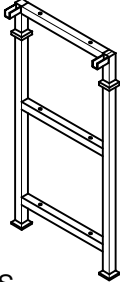
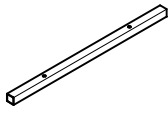
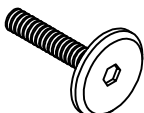
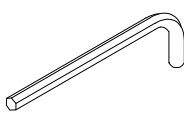

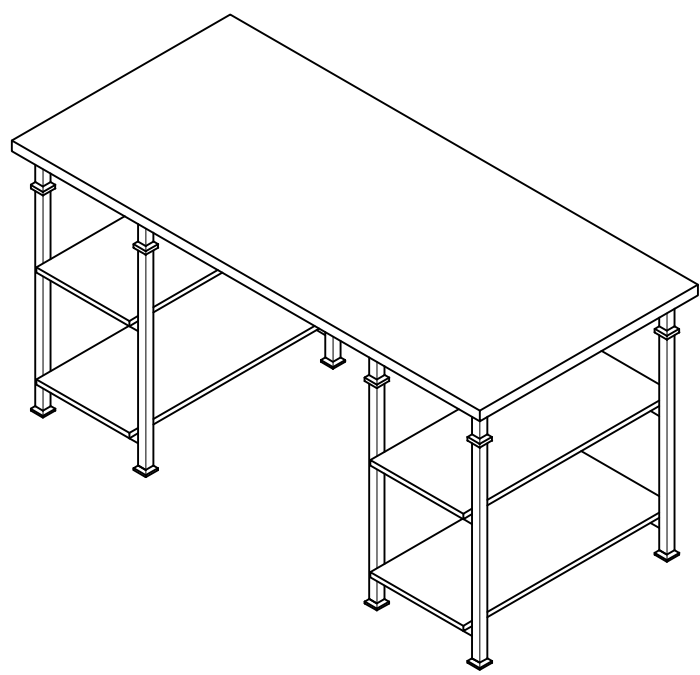
This page lists all the contents included in the box. Please take the time to identify the hardware as well as the individual components to this product. As you unpack and prepare for assembly, place the contents on a carpeted or padded area to protect them from damage.

*** Do not tighten screws & bolts until the entire unit is completely assembled.

1 Connect Side Frame(C) to Crossbar(D) as shown.

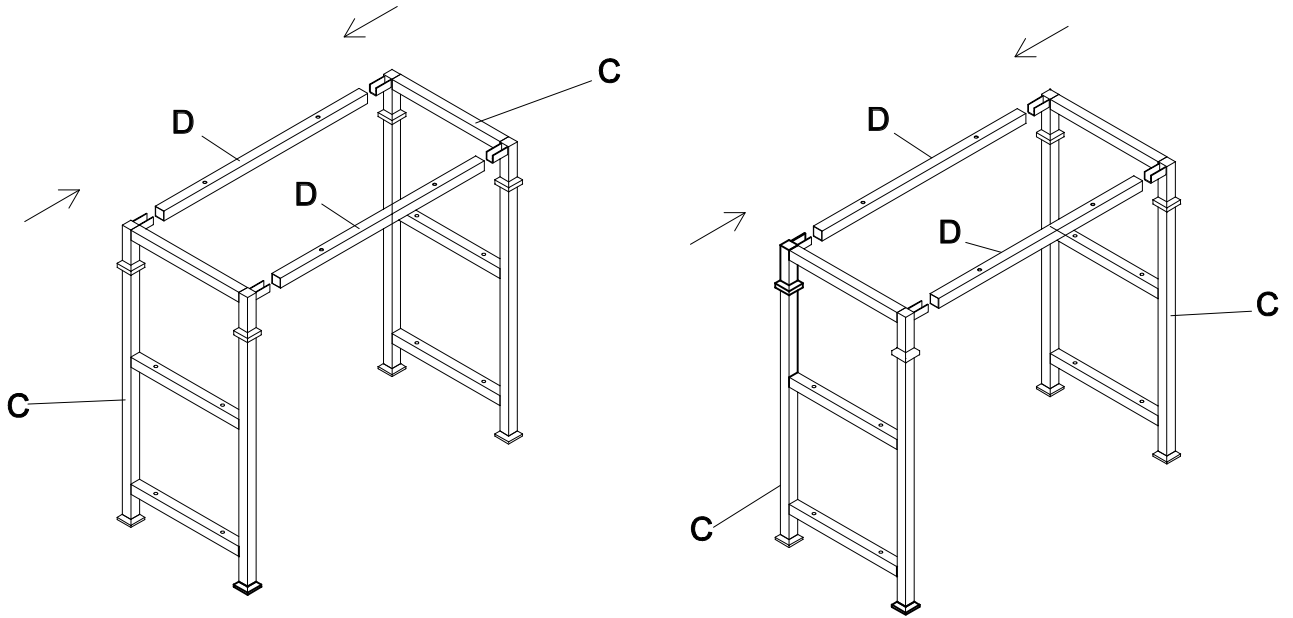

2 Attach Side Frame(C) to Crossbar(D) using Screw(G) and Allen Wrench(F) as shown.
Attach Side Frame(C) to Lower Panel(B) using Screw(E) and Allen Wrench(F) as shown.

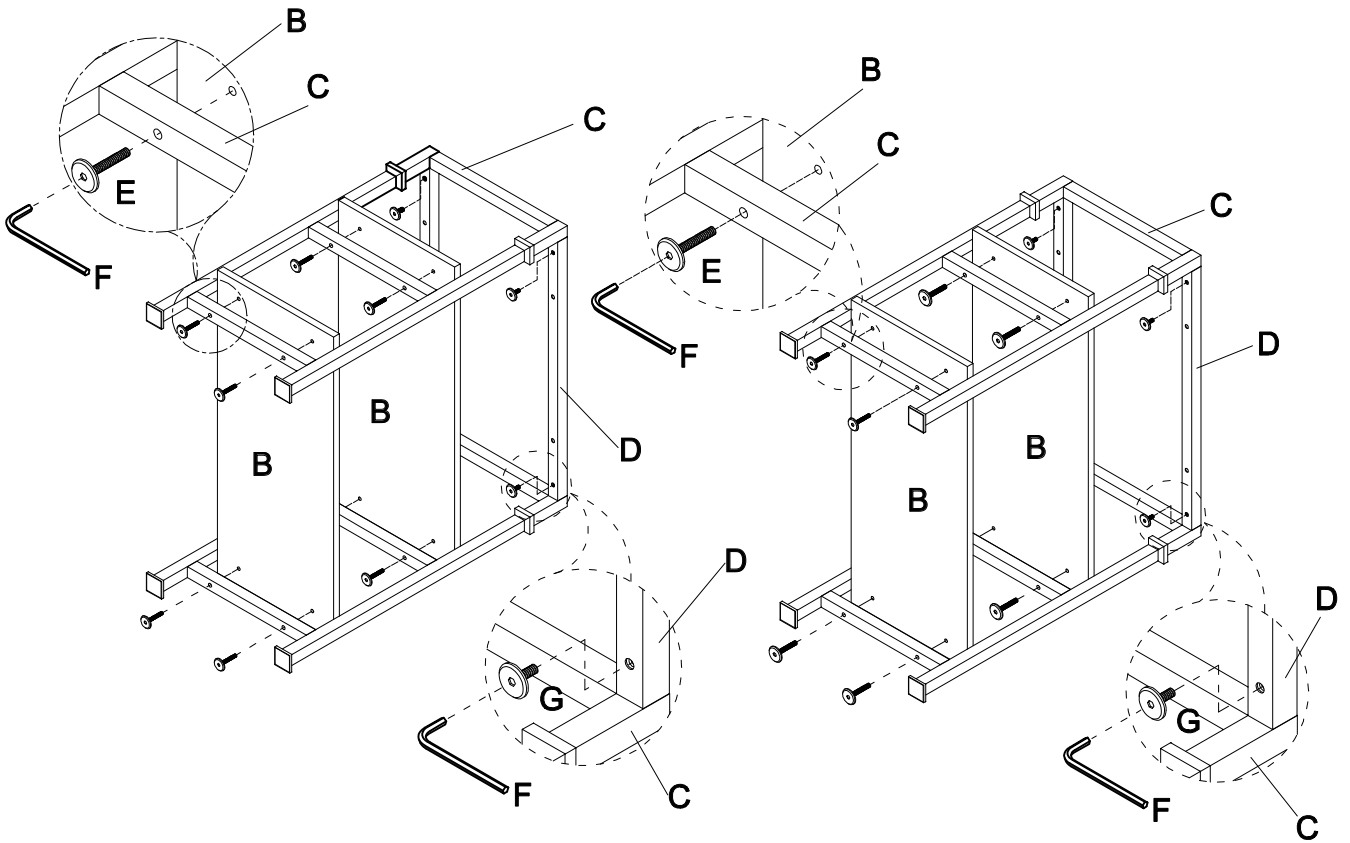

3

Attach Crossbar(D) to Top Panel(A) using Screw(E) and Allen Wrench(F) as shown. Tight all screws and carefully turn the assembled unit upright.

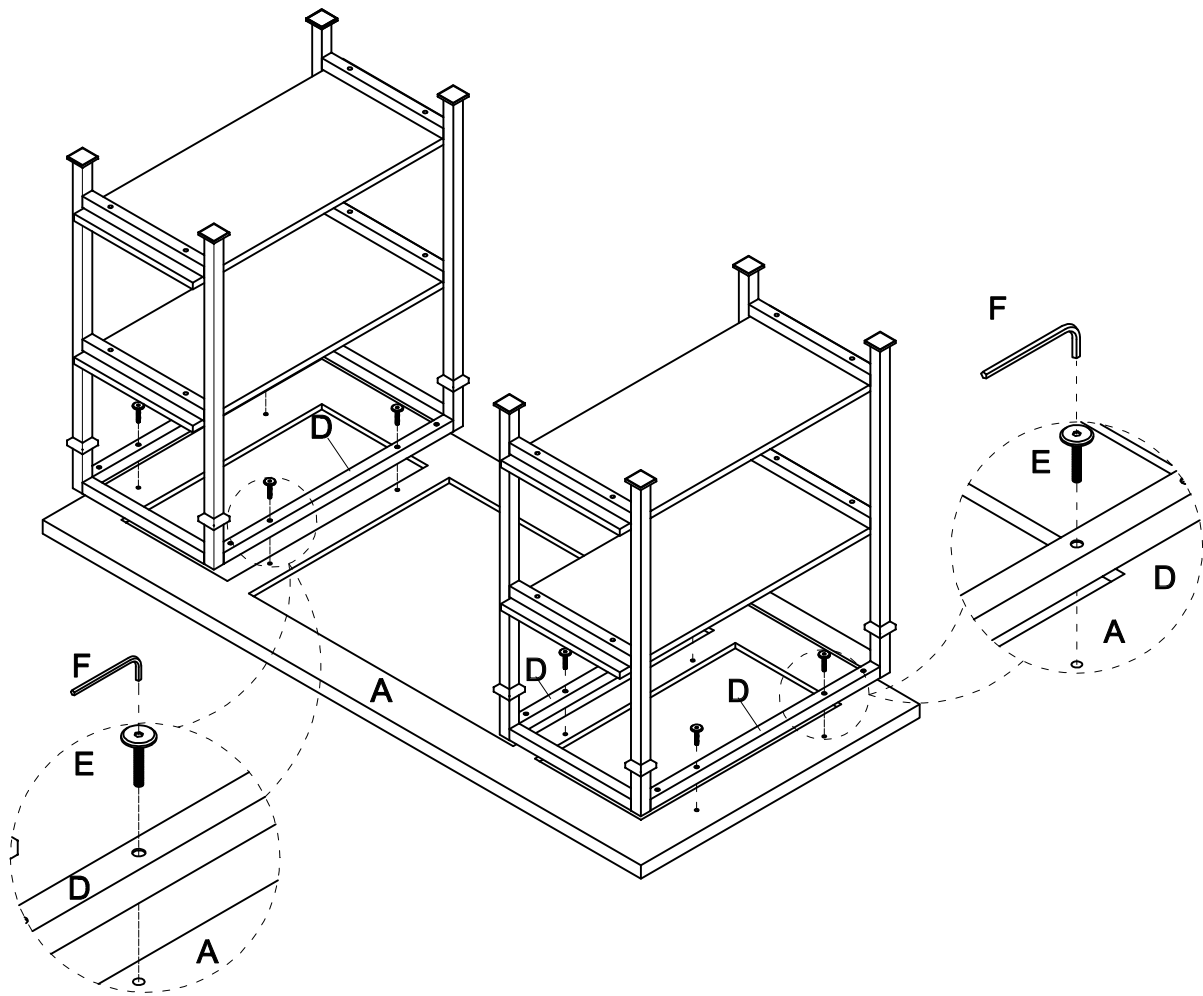

Cleaning & Care

Treat surface with care. Surface is resistant to scratches but is not scratch resistant. Clean surfaces with a dry or damp soft cloth. Do not use abrasive cleaners. Hardware may loosen over time. Periodically check that all connections are tight.