

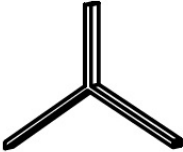

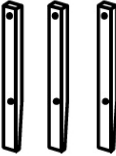

# ASSEMBLY INSTRUCTION

## FAUX MARBLE TOP END TABLE

<b>A</b> Table Top	<b>B</b> Connector	<b>C</b> Table Leg	<b>D</b> JCBC Bolt M8 x 40mm
			
1 pc	1 pc	3 pcs	6 pcs
<b>E</b> Lock Washer M8	<b>F</b> Flat Washer M8 x 16	<b>G</b> Allen Key M5	
			
6 pcs	6 pcs	1 pc	

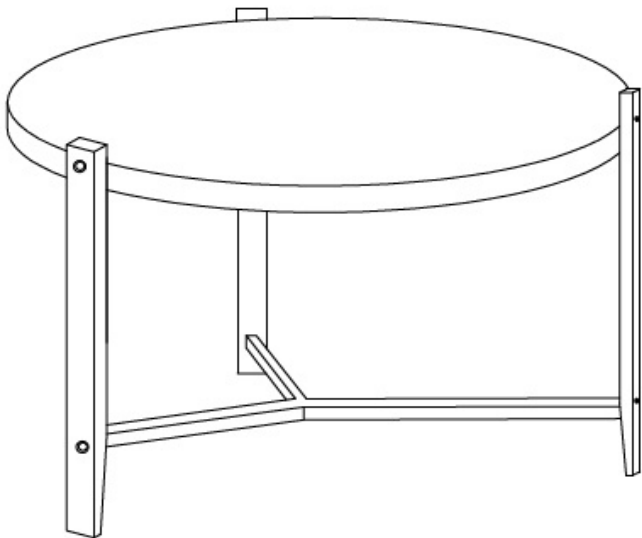

This page lists all the contents included in the box. Please take the time to identify the hardware as well as the individual components to this product. As you unpack and prepare for assembly, place the contents on a carpeted or padded area to protect them from damage.

- 1 Place the Table Top (A) upside down on a smooth carpeted surface. Place the Table Leg (C) to the position, aligning the hole of the Table Leg (C) with the hole of metal connector on the Table Top (A) as shown below. Then insert Flat Washer (F), Lock Washer (E) and JCBC Bolt (D) with Allen Key (G). Do not fully tighten the bolts at this step.

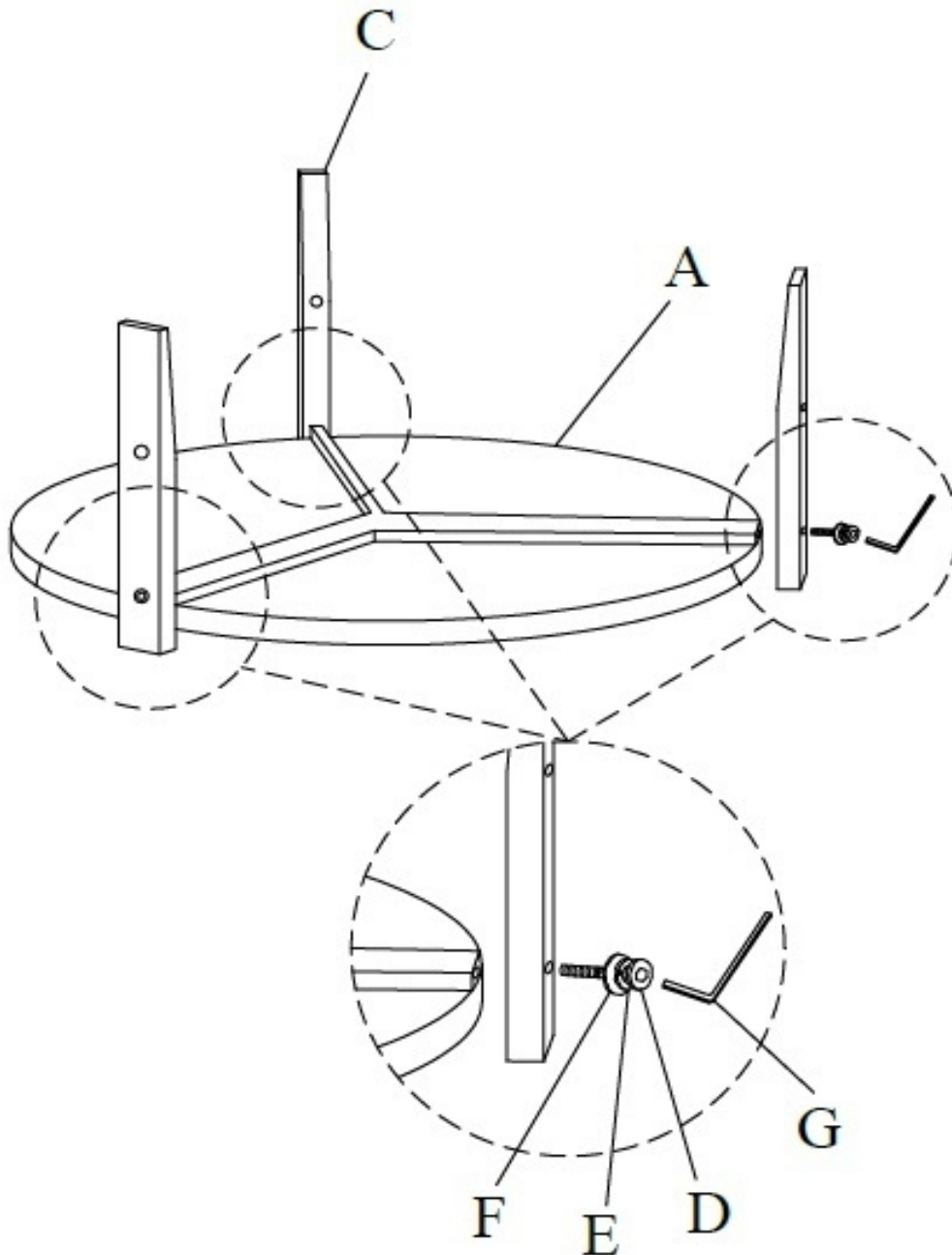

2

Attach Connector (B) with Table Leg (C) by using Flat Washer (F), Lock Washer (E) and JCBC Bolt (D) with Allen Key (G). Fully tighten the bolts at this step.

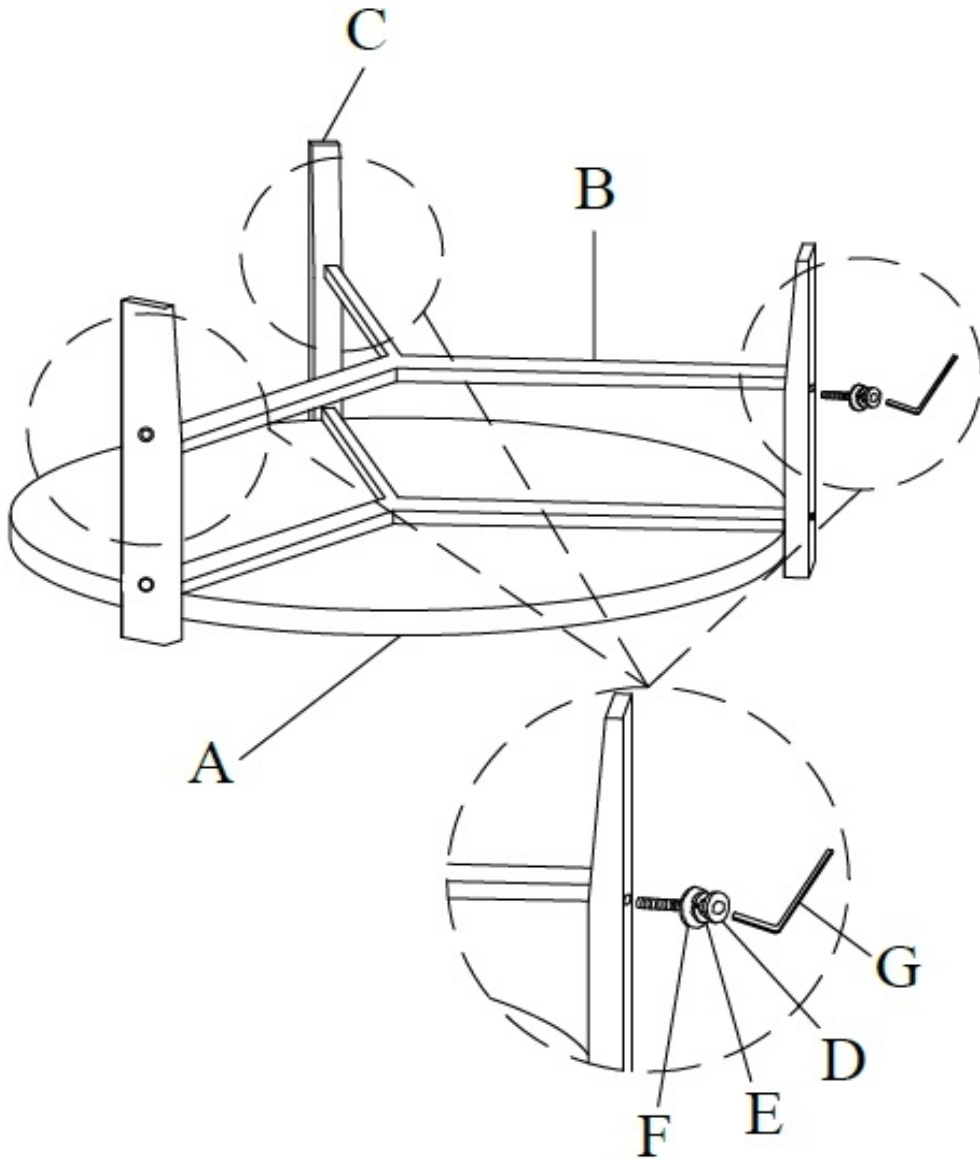





---

### Cleaning & Care

Treat surface with care. Surface is resistant to scratches but is not scratch resistant. Clean surface with a dry or damp soft cloth. Do not use abrasive cleaners. Hardware may loosen over time. Periodically check that all connections are tight.

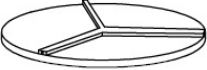
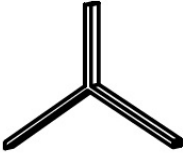
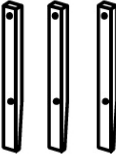
# ASSEMBLY INSTRUCTION

## FAUX MARBLE TOP COFFEE TABLE

<b>A</b> Table Top	<b>B</b> Connector	<b>C</b> Table Leg	<b>D</b> JCBC Bolt M8 x 40mm
			
1 pc	1 pc	3 pcs	6 pcs
<b>E</b> Lock Washer M8	<b>F</b> Flat Washer M8 x 16	<b>G</b> Allen Key M5	
			
6 pcs	6 pcs	1 pc	

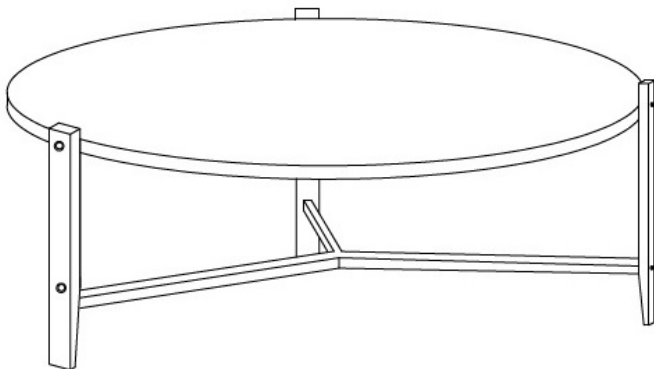

This page lists all the contents included in the box. Please take the time to identify the hardware as well as the individual components to this product. As you unpack and prepare for assembly, place the contents on a carpeted or padded area to protect them from damage.

- 1 Place the Table Top (A) upside down on a smooth carpeted surface. Place the Table Leg (C) to the position, aligning the hole of the Table Leg (C) with the hole of metal connector on the Table Top (A) as shown below. Then insert Flat Washer (F), Lock Washer (E) and JCBC Bolt (D) with Allen Key (G). Do not fully tighten the bolts at this step.

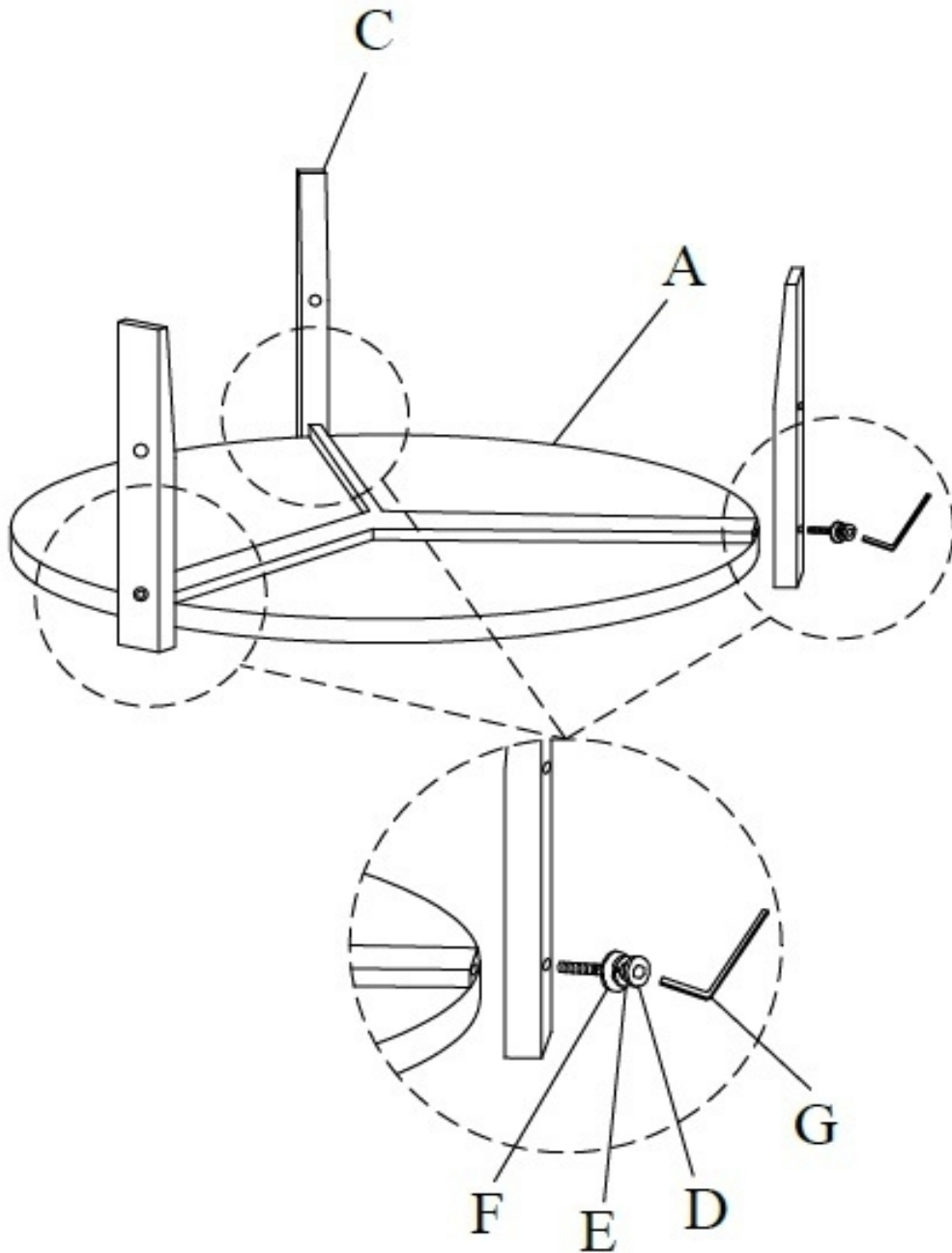

- 2 Attach Connector (B) with Table Leg (C) by using Flat Washer (F), Lock Washer (E) and JCBC Bolt (D) with Allen Key (G). Fully tighten the bolts at this step.

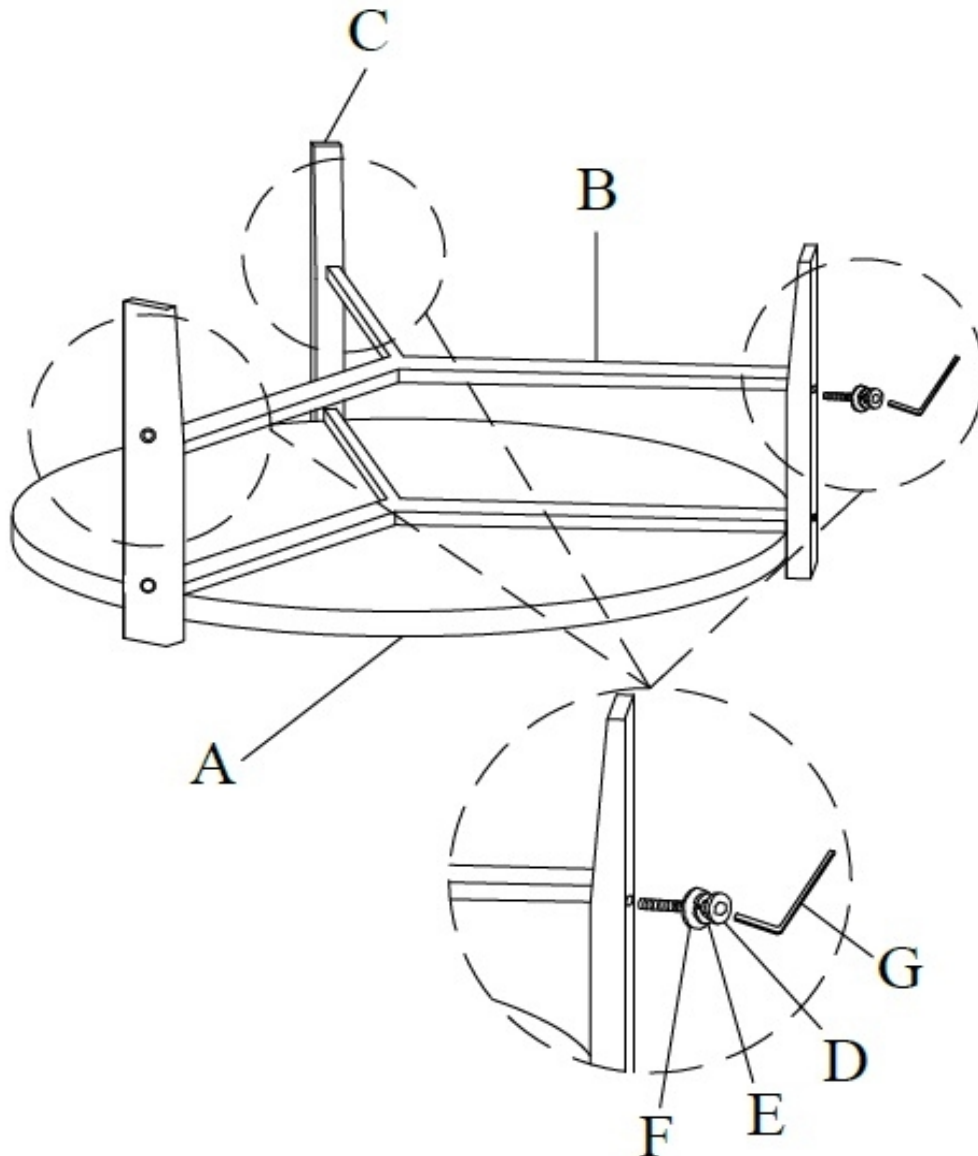

---

### Cleaning & Care

Treat surface with care. Surface is resistant to scratches but is not scratch resistant. Clean surface with a dry or damp soft cloth. Do not use abrasive cleaners. Hardware may loosen over time. Periodically check that all connections are tight.