

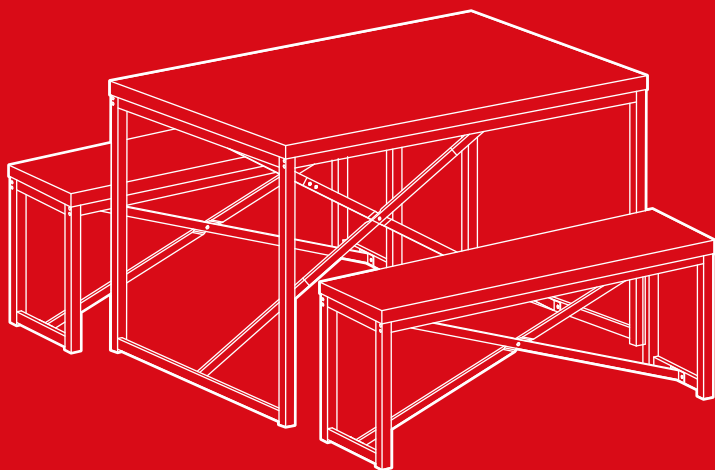

bestchoiceproducts



# INSTRUCTION MANUAL

---

Wooden Industrial Table  
and Bench



bestchoiceproducts

---

As shoppers, we're always trying to find the perfect balance between quality & value. At BCP, we believe we've achieved that. Our diverse catalog of everyday essentials is tailored especially to our customers & guaranteed to hit that sweet spot of high quality & low price.

— Always. —

## ! NOTICE

Please retain these instructions for future reference.

- Please do not exceed the weight limitations of this item.
- Do not stand on or use any part of this item as a step ladder.
- Firmly secure all bolts, screws, and knobs before use.
- Reconfirm that all bolts, screws, and knobs are secure every 90 days.
- Do not use or store this item in the proximity of open flame or flammable/combustible chemicals.
- If any parts are missing, broken, damaged, or worn, stop using this item until repairs are made and/or factory replacement parts are installed.
- Do not use this item in a way inconsistent with the manufacturer's instructions as this could void the product warranty.

## TOOLS REQUIRED



ALLEN WRENCH  
(PROVIDED)



WRENCH  
(PROVIDED)



176 LBS  
TABLE  
CAPACITY



500 LBS  
BENCH  
CAPACITY



1 PERSON  
ASSEMBLY



UP TO 45 MIN.  
ASSEMBLY

## HARDWARE

**A** M6 X 10MM  
SCREW



32 PCS

**B** M6 X 20MM  
SCREW



3 PCS

**C** M6 X 40MM  
SCREW



14 PCS

**D** M6 X 50MM  
SCREW



24 PCS

**E** M6 NUT



3 PCS

**F** ENDCAP  
(SKY5857 ONLY)



39 PCS



Part F endcap are only included in SKY5857.

## PARTS

1

TABLETOP



1 PC

2

TABLE SIDE



2 PCS

3

TABLE FRAME



2 PCS

4

SUPPORT CONNECTOR

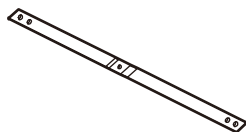

2 PCS

5

TABLE SUPPORT

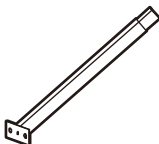

4 PCS

6

BENCH SEAT



2 PC

7

BENCH SIDE



4 PCS

8

BENCH FRAME



4 PCS

9

BENCH SUPPORT

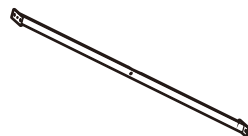

4 PCS

## PRODUCT ASSEMBLY

1

Attach two part 5 table supports to one part 4 support connector with four part A screws, then cover with four part F end caps.

Repeat to assemble the second table support.

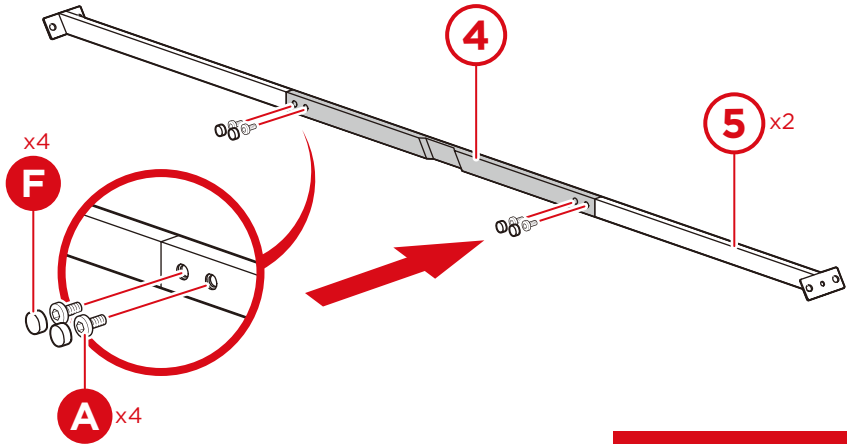

Part F endcap are only included in SKY5857.

2

Attach two part 2 table sides to two part 3 table frames with eight part D screws, then cover with eight part F end caps. Attach one support beam assembly to two part 2 table sides with four part A screws, then cover the bottom screws with two part F end caps.

Repeat to attach the second support beam assembly.

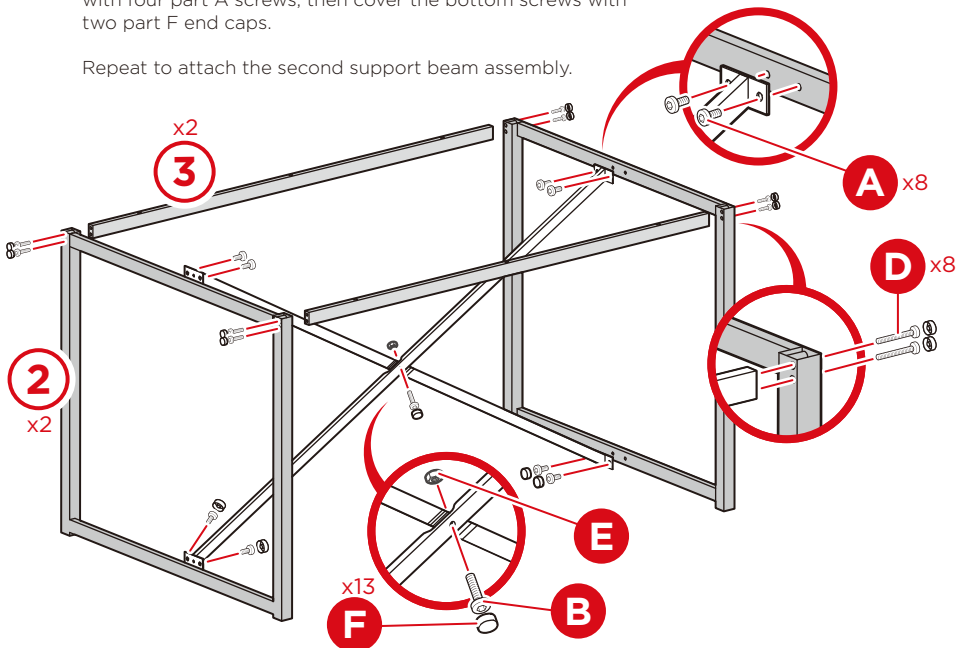

Connect the two part 4 support connectors with one part B screw and one part E nut, then cover with one part F end cap.

## PRODUCT ASSEMBLY

3

Place the part 1 tabletop face down, then place the table assembly on top. Secure with six part C screws.

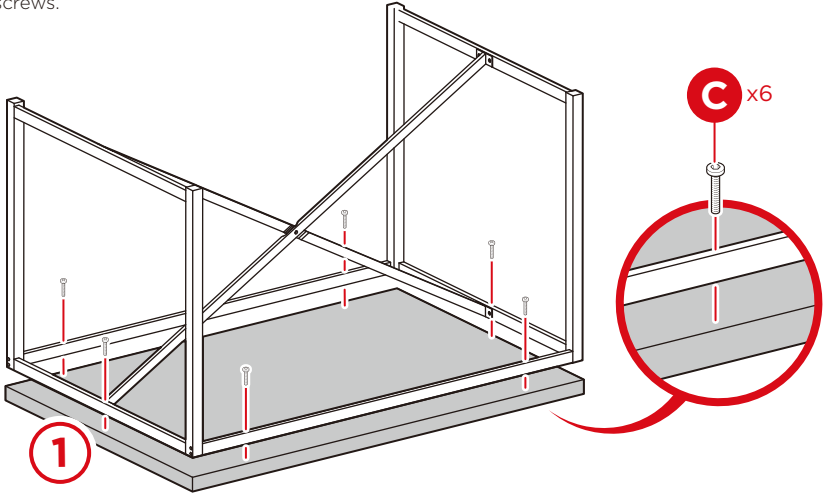

4

Connect two part 7 bench sides to two part 8 bench frames with eight part D screws, then cover with eight part F end caps. Attach one part 9 bench support to two part 7 bench sides with four part A screws.



Part F endcap are only included in SKY5857.

Repeat to attach the second bench support.

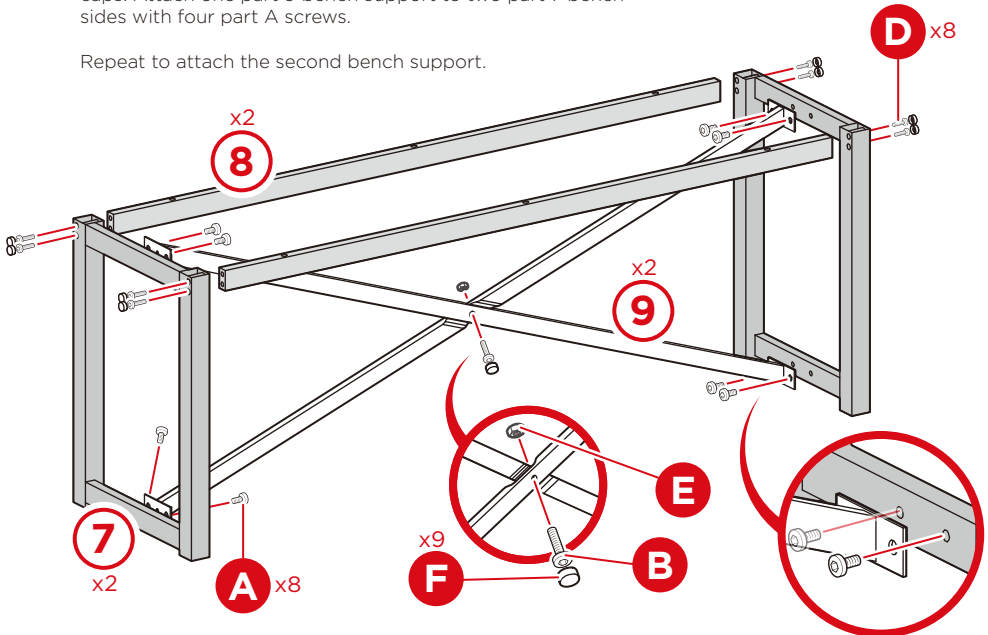

## PRODUCT ASSEMBLY

5

Place the part 6 bench seat face down, then place the bench assembly on top. Secure with four part C screws.

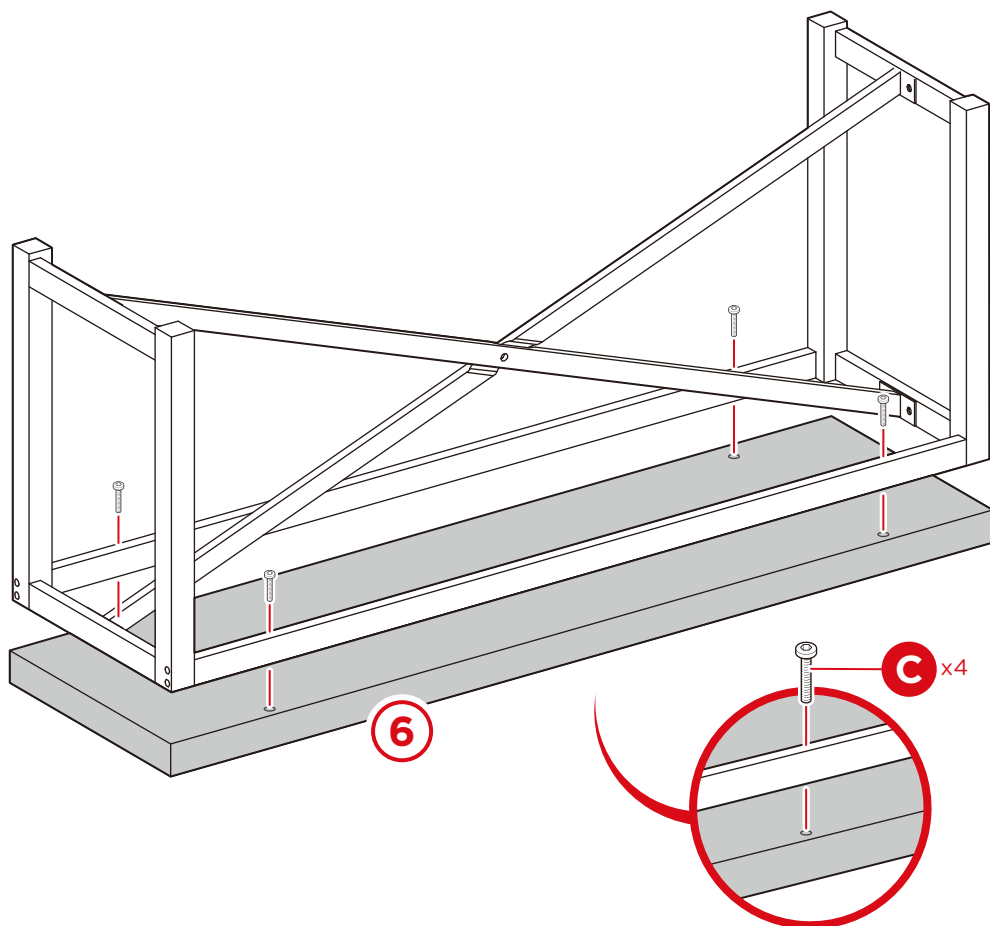



# HELP CENTER



Question about your product? We're here to help. Visit us at:

[help.bestchoiceproducts.com](http://help.bestchoiceproducts.com)



Product Assembly



Returns & Refunds

## PRODUCT WARRANTY INFORMATION

All items can be returned for any reason within 60 days of the receipt and will receive a full refund as long as the item is returned in its original product packaging and all accessories from its original shipment are included. All returned items will receive a full refund back to the original payment method. All returned items will not be charged a re-stocking fee.

All returned items require an RA (Return Authorization) number, which can only be provided by a Best Choice Products Customer Service Representative when the return request is submitted. Items received without an RA may not be accepted or may increase your return processing time. Once an item has been received by Best Choice Products, refunds or replacements will be processed within 5 business days.

All returns must be shipped back to the Best Choice Products Return Center at the customer's expense. If the reason for return is a result of an error by Best Choice Products then Best Choice Products will provide a pre-paid shipping label via email. Boxes for return shipping will not be provided by Best Choice Products, and is the customer's responsibility to either use the original shipping boxes or purchase new boxes.

Pictures may be required for some returns to ensure an item is not damaged prior to its return. Items returned are not considered undamaged until they are received by Best Choice Products and verified as such. All damages to items are the customer's responsibility until the item has been received by and acknowledge by Best Choice Products as undamaged.

## WARNING

Manufacturer and seller expressly disclaim any and all liability for personal injury, property damage or loss, whether direct, indirect, or incidental, resulting from the incorrect attachment, improper use, inadequate maintenance, unapproved modification, or neglect of this product.