

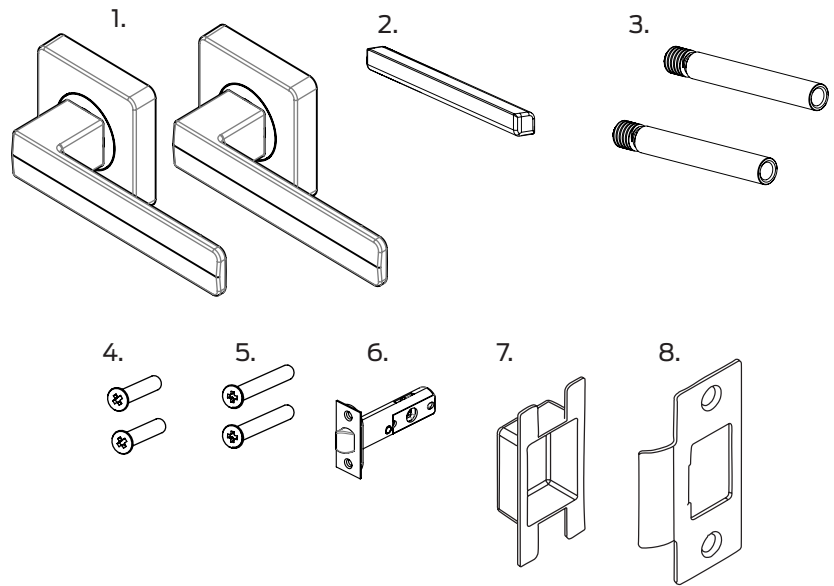

# Verta Passage Set Installation Instructions

## Contents

1. 1 x Passage Lever Set
2. 1 x Spindle
3. 2 x Studs
4. 2 x Fixing Screws (M4 x 25mm)
5. 2 x Fixing Screws (M4 x 35mm)
6. 1 x Latch
7. 1 x Dust Box
8. 1 x Strike Plate



## Tools Required

- Tape measure
- Soft pencil
- Level
- 6.5mm, 22mm & 24mm drill bits
- Power drill
- Philips screwdriver

## Note

Check door thickness first

- For doors 35-40mm thick, use 20mm M4 screws (x2)
- For doors 40-50mm thick, use 30mm M4 screws (x2)

## Step 1: Door Preparation

If door is predrilled, go to step 2, otherwise follow the steps below

- 1.1 With a soft pencil, mark holes as per template
- 1.2 Check alignment using a level
- 1.3 Drill holes
- 1.4 Mark the centre for the latch hole and drill  $\text{Ø}24 \text{ mm} \times 85 \text{ mm}$  deep

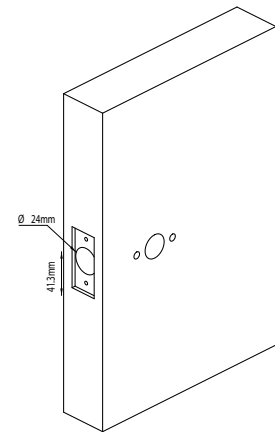

## Step 2. Install Latch

- 2.1 Insert latch into hole. Trace around the face plate
- 2.2 Chisel until faceplate fits flush with door edge
- 2.3 Drill 2 pilot holes for latch fixing screws
- 2.4 Fasten the latch so the bevelled edge of latch-bolt faces jamb

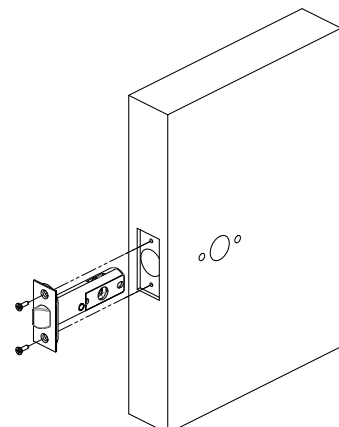

### Step 3: Furniture Installation

- 3.1 Screw studs onto external rose. Insert spindle into furniture
- 3.2 Align studs with drilled holes and mount external furniture to door
- 3.3 Secure the internal furniture with M4 screws
- 3.4 Install rose caps so they are flush with the door surface

3.1

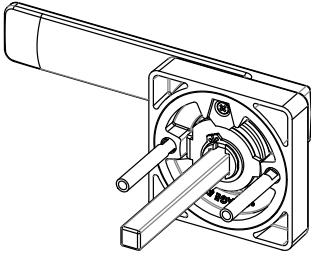

3.2

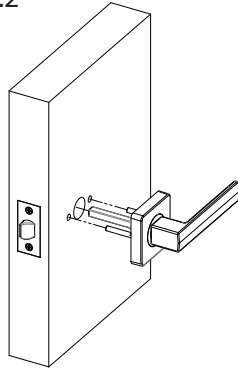

3.3

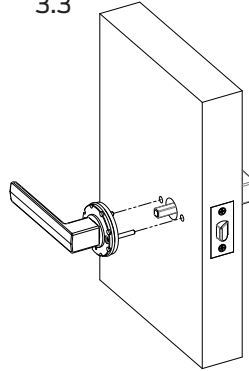

3.4

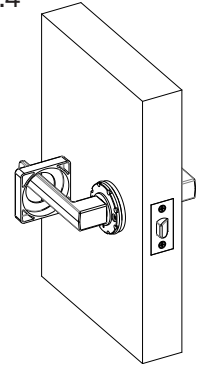

### Step 4: Prepare Jamb & Install Strike

- 4.1 Mark vertical and horizontal centreline on jamb, exactly opposite centre of latch
- 4.2 Use strike plate as pattern for cut-out. Chisel until strike plate fits flush with jamb face
- 4.3 Using strike plate as pattern, chisel or drill 15mm deep for latch hole
- 4.4 Drill 2 pilot holes for strike fixing screws
- 4.5 Fasten with screws

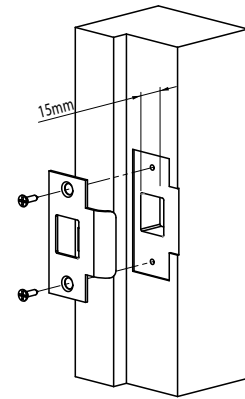

#### Allegion New Zealand

Freephone 0800 477 869  
Email [nzinfo@allegion.com](mailto:nzinfo@allegion.com)  
[www.allegion.co.nz](http://www.allegion.co.nz)



For more  
information visit  
[schlage.co.nz/verta](http://schlage.co.nz/verta)

PDSC0054

© 2024 Allegion

