

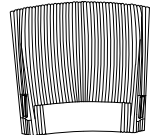

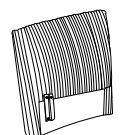

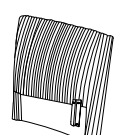
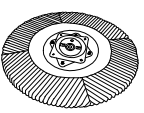
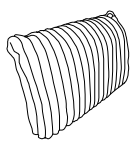

# ASSEMBLY INSTRUCTIONS

## SWIVEL ACCENT CHAIR WITH FURRY CHANNEL PILLOW

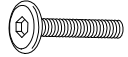
<b>A</b> Cushion Seat  1 pc	<b>B</b> Middle Backrest  1 pc	<b>C</b> Left Armrest  1 pc	<b>D</b> Right Armrest  1 pc
<b>E</b> Swivel Base  1 pc	<b>F</b> Back Pillow  1 pc	<b>G</b> Metal Connector 3-1/2" x 31/32" x 1/8"  6 pcs	<b>H</b> Bolt Ø1/4" x 31/32"  16 pcs
<b>I</b> Spring Washer Ø1/4" x 7/16"  16 pcs	<b>J</b> Flat Washer Ø1/4" x 3/4"  16 pcs	<b>K</b> Allen Key 2-3/4" x 2-3/4" x 3/16"  1 pc	

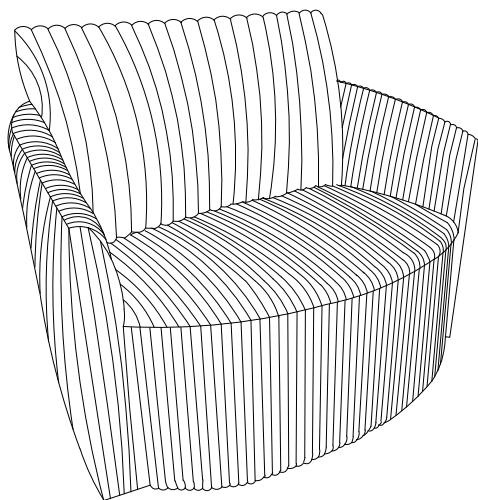

This page lists all the contents included in the box. Please take the time to identify the hardware as well as the individual components to this product. As you unpack and prepare for assembly, place the contents on a carpeted or padded area to protect them from damage.

### IMPORTANT NOTE:

1. Do not fully tighten all screws / bolts until the assembly is completely assembled.
2. Keep all hardware parts out of reach of children.

**\*\*\* Do not fully tighten all screws / bolts until the assembly is completely assembled.**

**1** Attach the Left & Right Armrest (C & D) to the Middle Backrest (B).

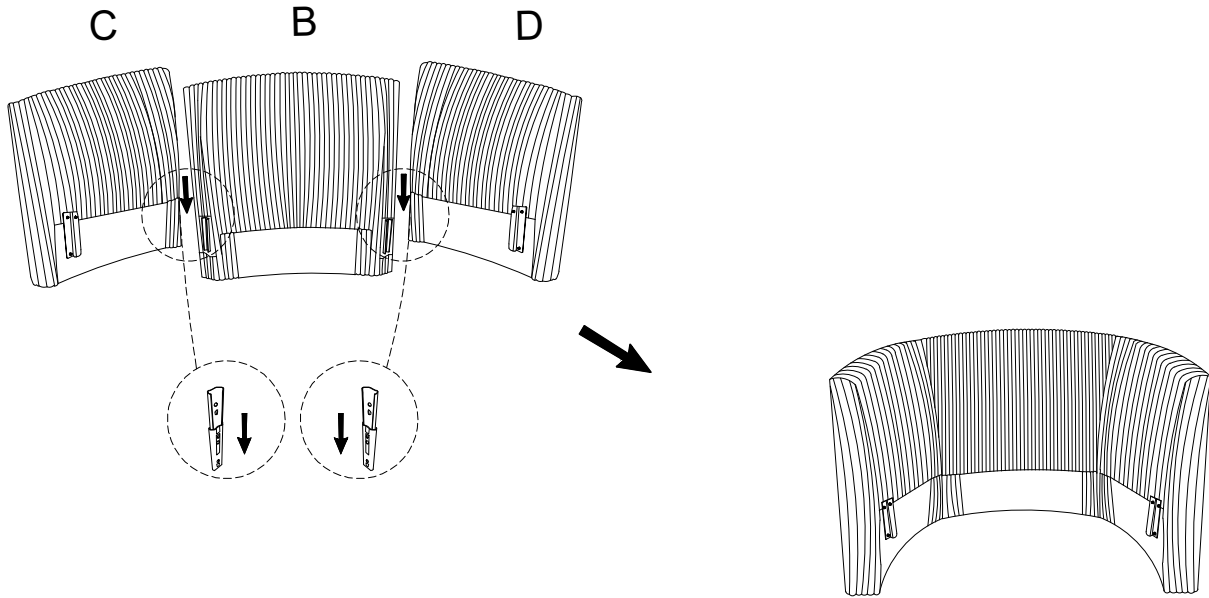

**2** Attach the Backrest (C & B & D) to the Cushion Seat (A).

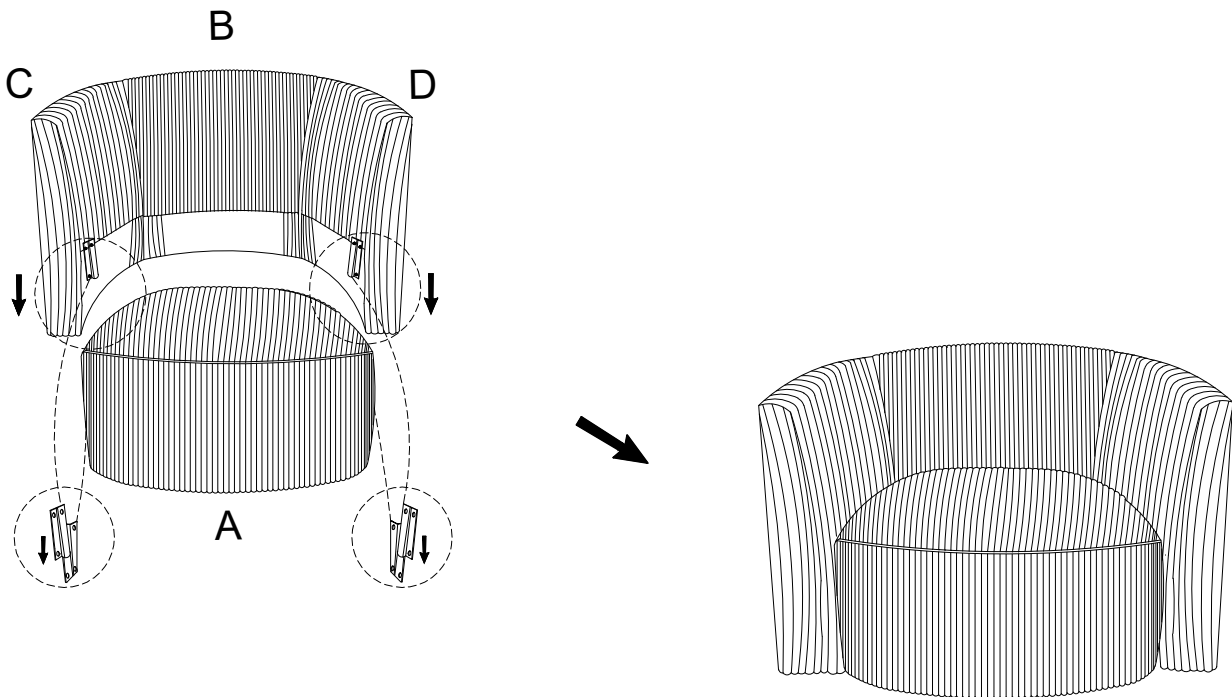

**\*\*\* Do not fully tighten all screws / bolts until the assembly is completely assembled.**

- 3** Attach the Backrest (C & B & D) to the Cushion Seat (A) by the Metal Connector (G) using Bolt (H), Spring Washer (I) and Flat Washer (J) with the Allen Key (K).

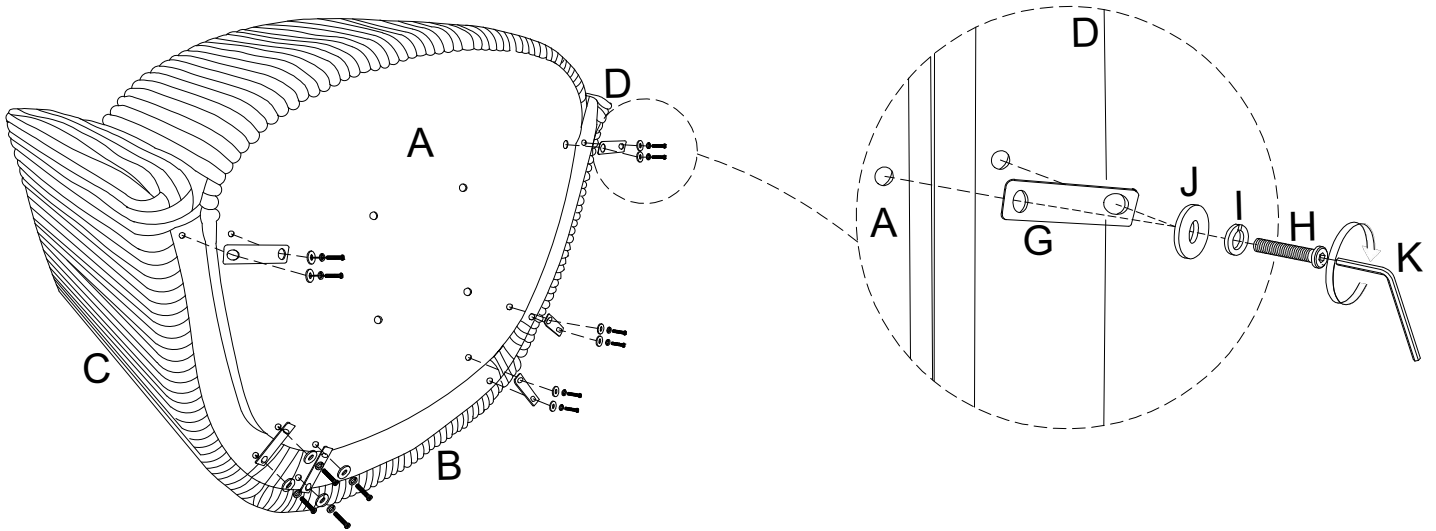

- 4** Attach the Swivel Base (E) to the Cushion Seat (A) using Bolt (H), Spring Washer (I) and Flat Washer (J) with the Allen Key (K). First, secure two holes, then rotate and secure the other two holes.

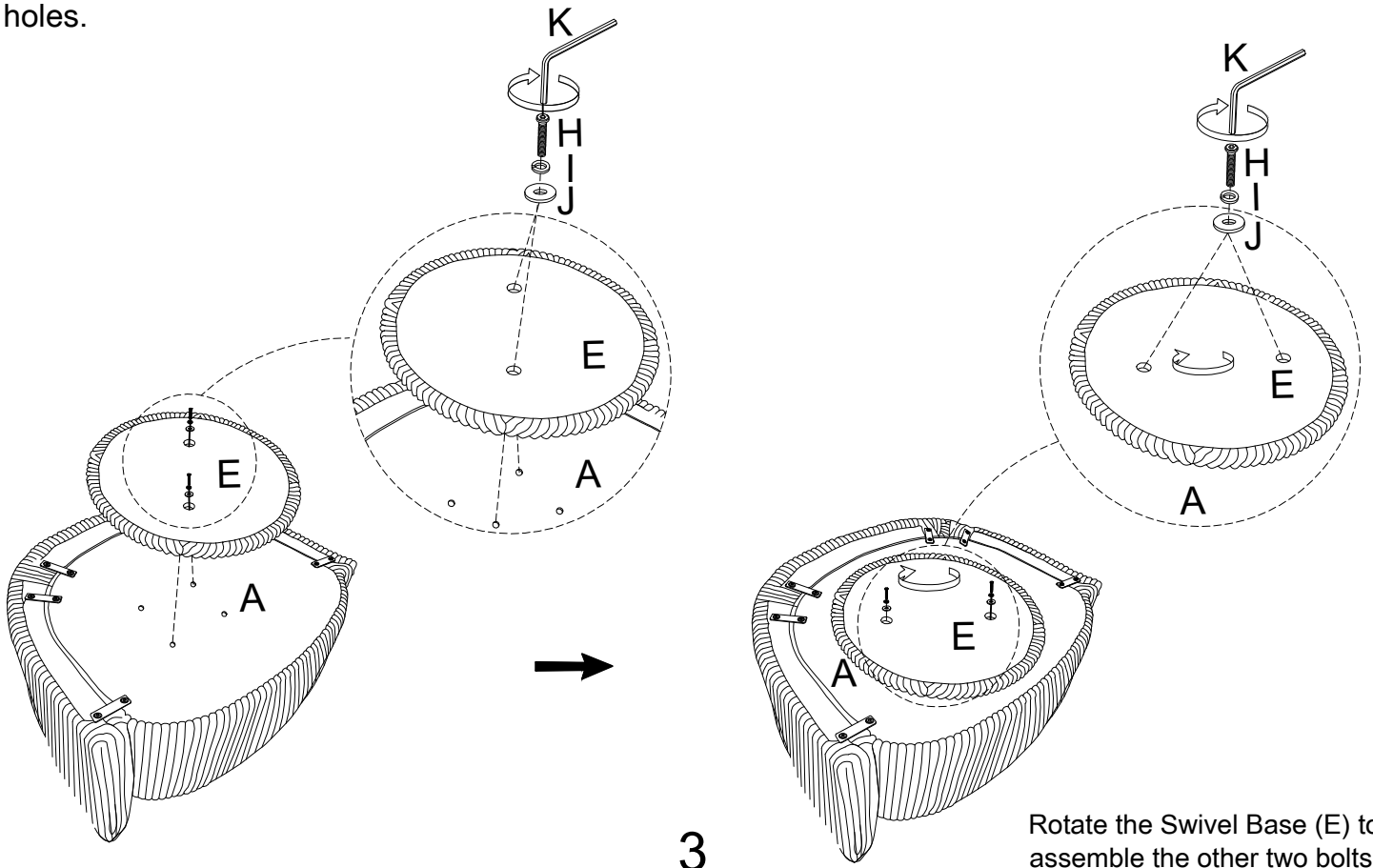

Rotate the Swivel Base (E) to assemble the other two bolts.

**\*\*\* Do not fully tighten all screws / bolts until the assembly is completely assembled.**

**5** Place the Back Pillow (F) on the Cushion Seat (A).

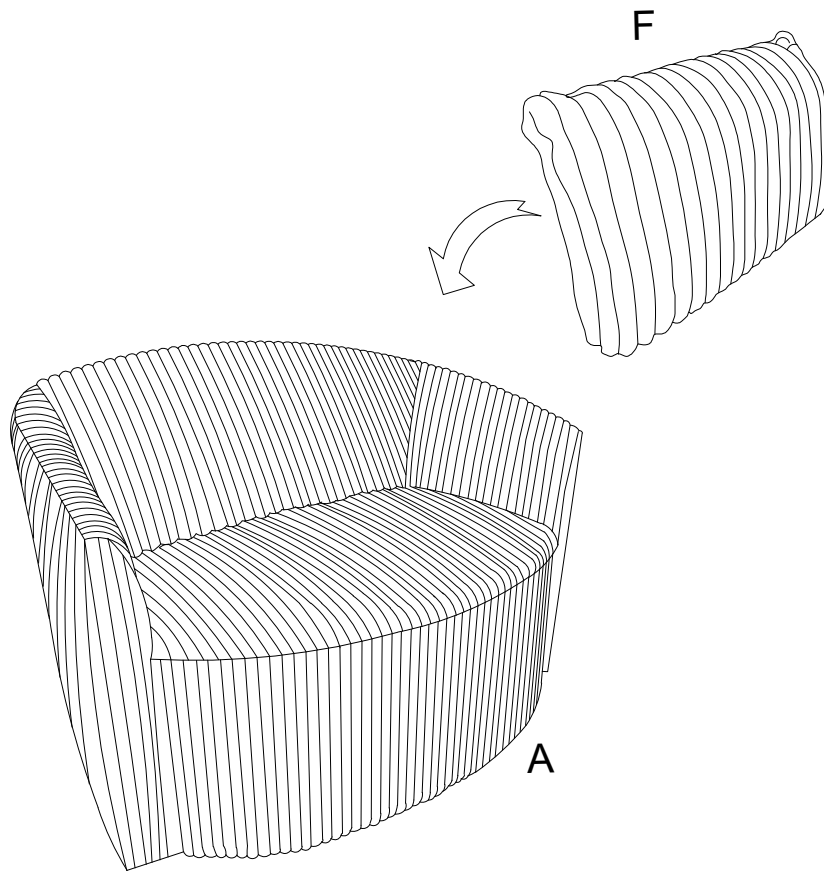

### **Cleaning & Care**

Treat surfaces with care. Surfaces are resistant to scratches but are not scratch resistant. Clean surfaces with a dry or damp soft cloth. Do not use abrasive cleaners. Hardware may loosen over time. Periodically check that all connections are tight.