

**WALKER EDISON**  
TM

# Bronx Modern Solid Wood Dresser

SKU# BR60BRX6D-T

LOT: **AAYYWW-XXXX**

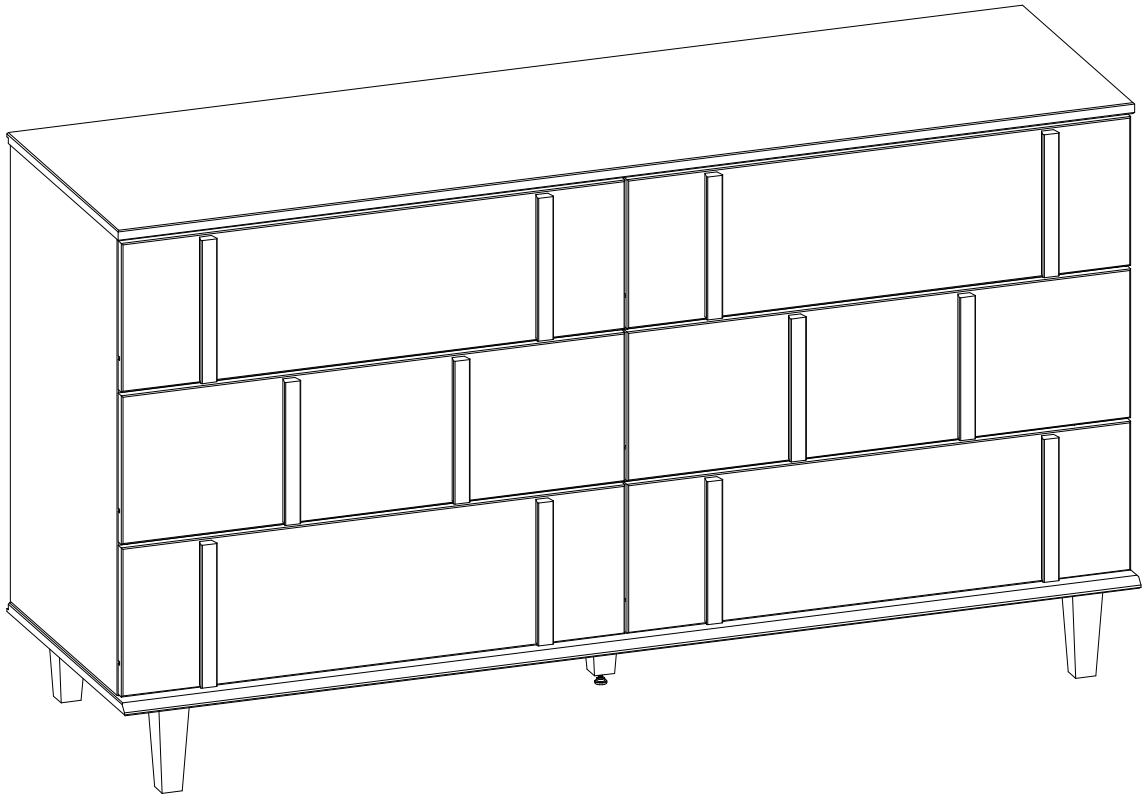

**For Residential Use Only**

Please visit our website for the most current instructions, assembly tips, report damage, or request parts. [www.walkeredison.com](http://www.walkeredison.com)

# WE Time to get started

Set up a clean and soft workplace to avoid damage during assembly. You can use the box and internal protections as a cover. It also helps to double-check if you have got all the pieces and parts before diving into the assembly.

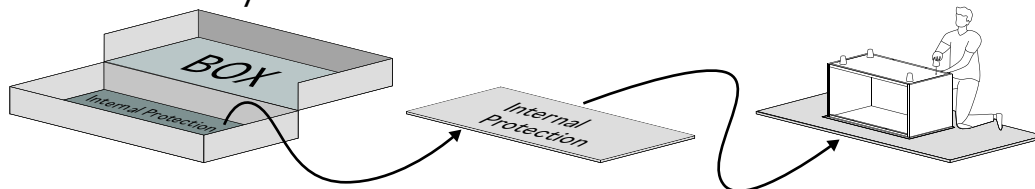

**Estimated time for assembly**

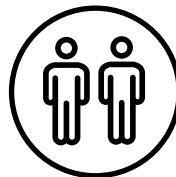

2 People Build

**People recommended for assembly**

Make it a team effort!  
Grab a friend for quicker, easier assembly.

## Tools Needed

Grab a Phillips head screwdriver and a hammer to conquer this assembly.

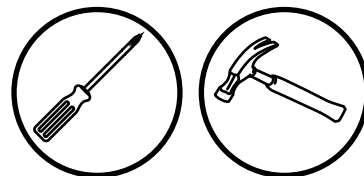

## Use power tools with caution

This furniture is made of Solid Wood and Composite Wood, soft materials. If you choose to use power tools, set it to the slower setting. Be careful! Power tools can cause cracking or damage to the furniture, they can also damage the hardware if misused.

Power tool damages are not covered by the Walker Edison warranty.

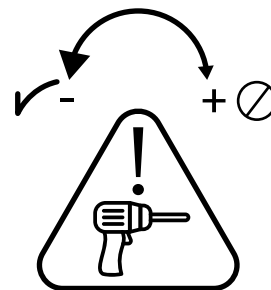

## Slide care

Your furniture has highly durable wooden sliders. From time to time we recommend applying paraffin or standard candle wax to improve gliding of the sliders.

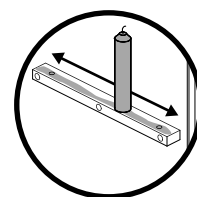

**Scan to get assembly tips and help!**

# WE Parts List

Part Number	Description	Quantity
1	Top Panel	1
2	Left side panel	1
3	Right side panel	1
4	Bottom panel	1
5	Division	1
6	Large Wood slider	6
7	Back Panel	2
8	Back rail	1
9	Foot	4
10	Central foot	1

Part Number	Description	Quantity
11	Drawer handle	12
12	Center Drawer Front	2
13	Drawer Front	4
14	Drawer bottom	6
15	Drawer back	6
17	Wood slider	6
18	Left drawer side	6
19	Right Drawer side with warning	1
21	Right drawer side	5

**WALKER EDISON**  
 Distribution and responsible for the anti-tip hardware:  
 Walker Edison Furniture Company  
 1553 W 9000 S, West Jordan, UT 84088 United States

Collection Name  
**QR COD.**

Model: XXXXXXXXFF  
 LOT: AAYYWW-XXXX  
 Date: MM/20YY  
 Rev: MM/20YY-VX

CANFER compliant / conforme au CANFER  
 TSCA Title VI compliant / conforme au titre VI de la TSCA  
 California 93120 Compliant for Formaldehyde / Conforme à la norme Californie 93120 pour le formaldéhyde.

For details on Assembly Videos, Assembly Instructions, Replacement Parts and Customer Service. SCAN HERE.

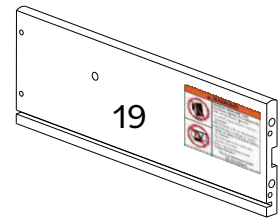



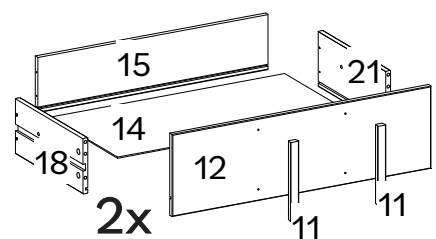
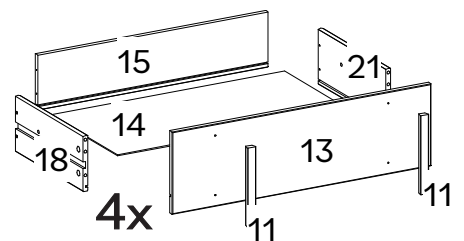
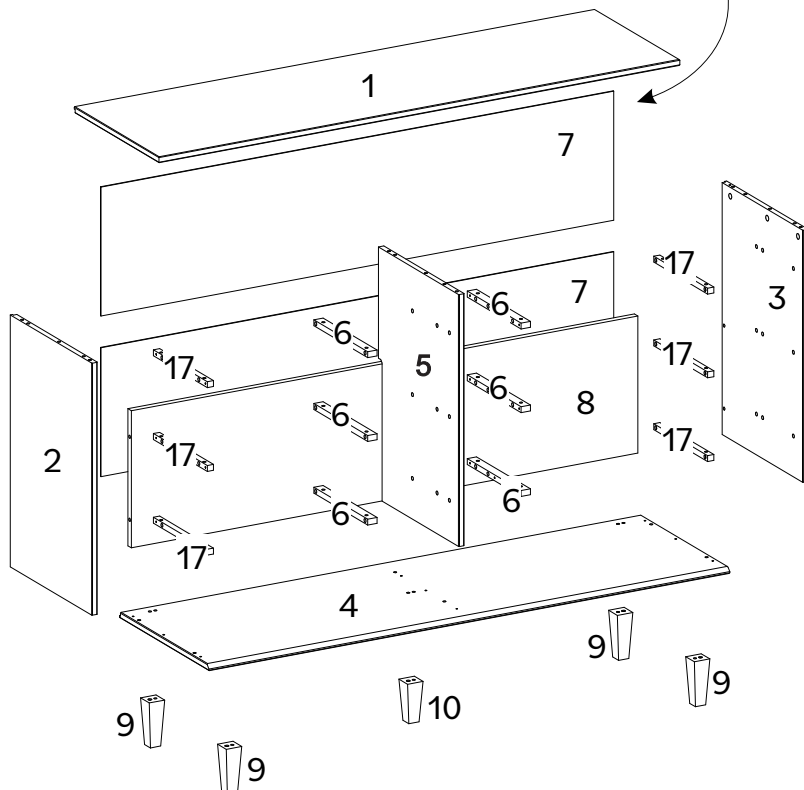





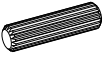

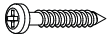
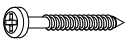

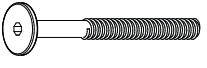
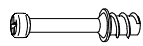
The side drawer with **WARNING LABEL**, should be mounted in highest drawer.

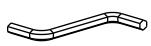

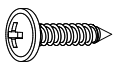
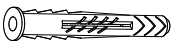
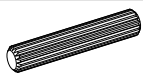

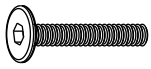
# Hardware List

Part	Size	Name	Quantity
A	 8x30mm	Wooden dowel	45
B	 10x20mm	Wooden dowel	36
C	 4x25mm	Screw	60
D	 3,5x30mm	Screw	24
E	 4,0x40mm	Screw	10
F	 10x7	Nail	35
G	 7x60mm	Bolt	03
H	 6x31mm	Cam Bolt	33
I	 15x12mm	Cam Lock	33
J	 15x15mm	Plate	07
K	 4mm	Hex Key	01
L		Wall anchor	01
M		Washer	02
N	 4x14mm	Screw	09
O	 6x35mm	Plastic bush	01
P	 8x40mm	Wooden dowel	12
Q		Threaded foot insert	01
R	 1/4x25mm	Threaded leveling foot	01
S	 7x40mm	Bolt	02
T	 75x50mm	Metal Plate	02

*The hardware quantities listed above are required for proper assembly.  
Extra hardware pieces may be included.*

# Step 1

Let's get started! Insert the Wooden dowels (B) into each Wood Slider (6) and (17).

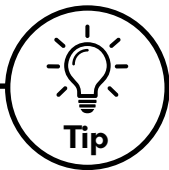
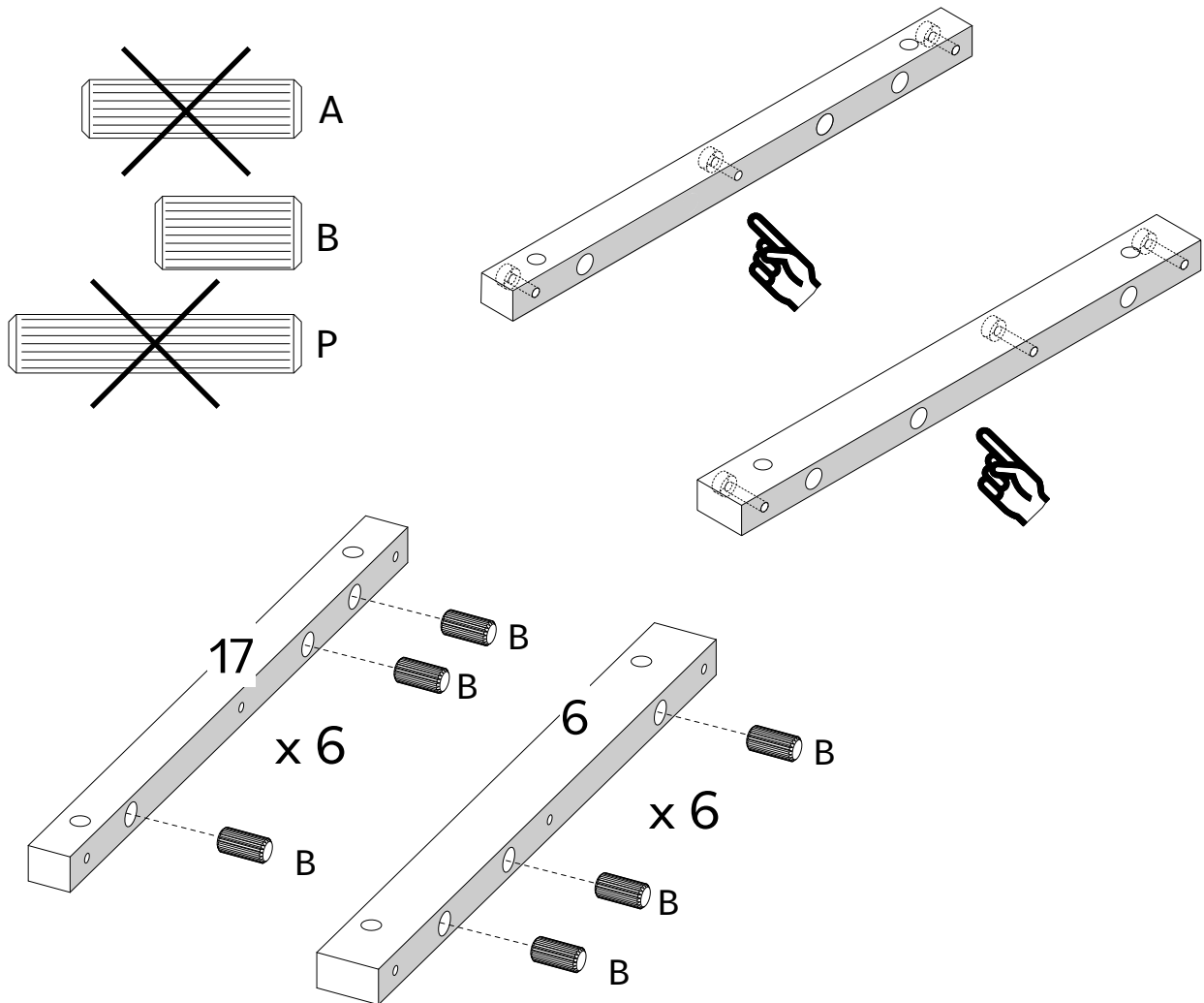

Tip

## Wood Dowels

Dowels are essential in furniture assembly to create strong, precise connections. They ensure structural integrity, prevent shifting, and simplify alignment, resulting in sturdier, longer-lasting furniture.

Follow these steps:

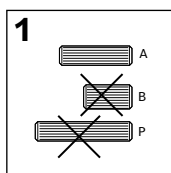

1: Select the appropriate size dowel according with step.

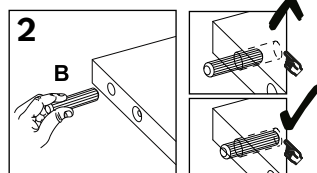

2: Insert into drilled hole and press firmly to ensure placement is set.

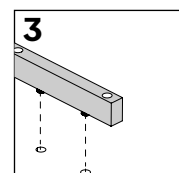

3: Align the dowel with corresponding piece and press together until secure.

# Step 2

Insert Wooden dowels (A) into the Left Side Panel (2), Right Side Panel (3), Division (5), Back Rail (8), Foot (9), Central Foot (10), Left Drawer Side (18), Right Drawer Side with Warning (19) and Right Drawer Side (21).

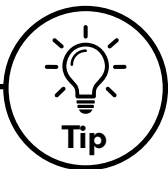
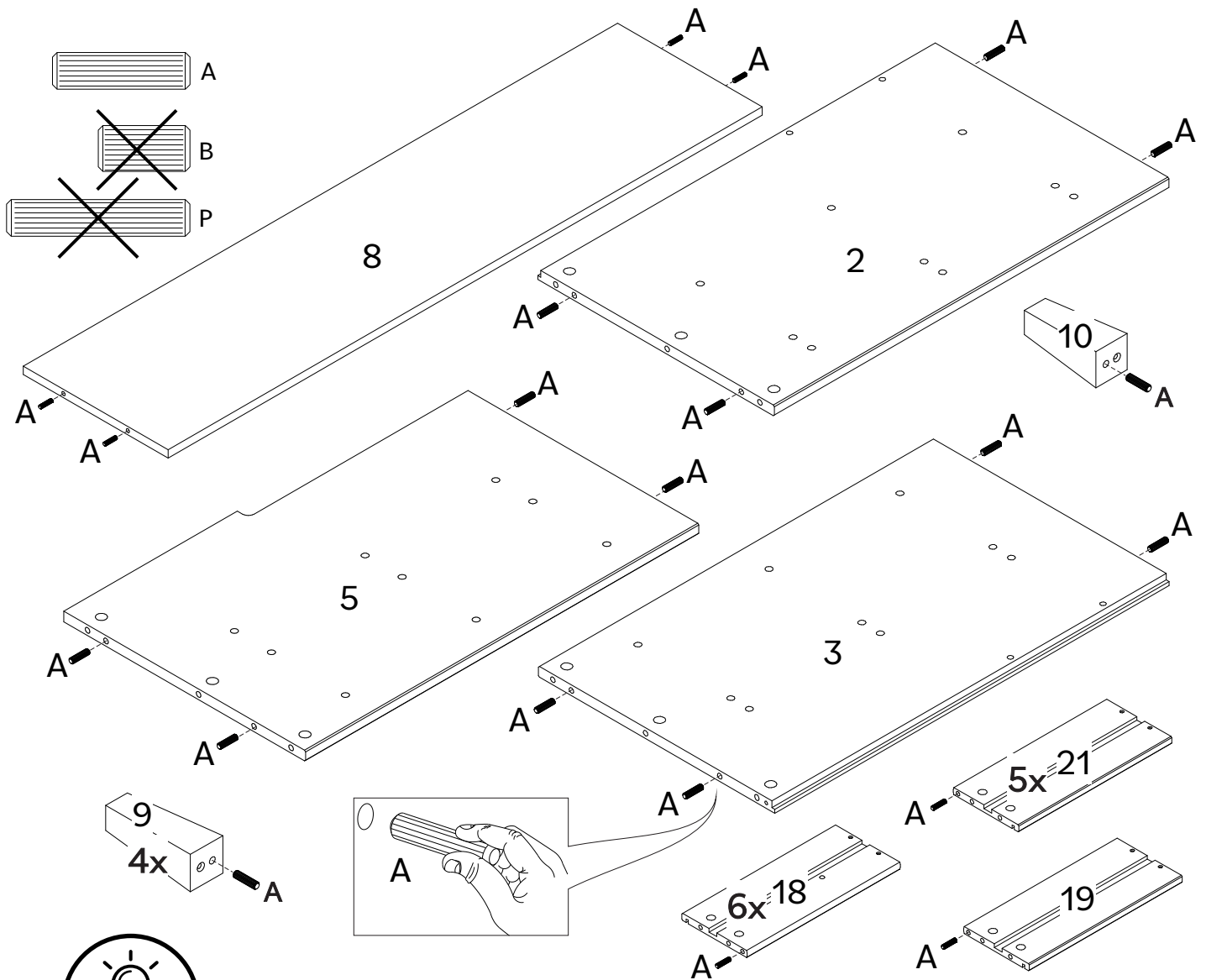

To keep your product looking its best and scratch-free, try assembling it on a soft surface like carpet or a blanket. This helps prevent any accidental scratches and keeps your furniture in top shape!

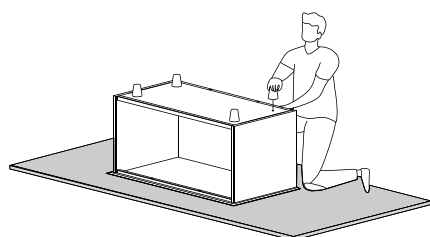

# Step 3

Insert Cam Bolt (H) into Top Panel (1), Drawer Front (12) and Drawer Front (13), using a Phillips Screwdriver.

1 - Ensure cam bolt is installed straight and not at an angle.  
2 - Tighten cam bolt until shoulder on cam bolt is flush.  
Do not over-tighten.

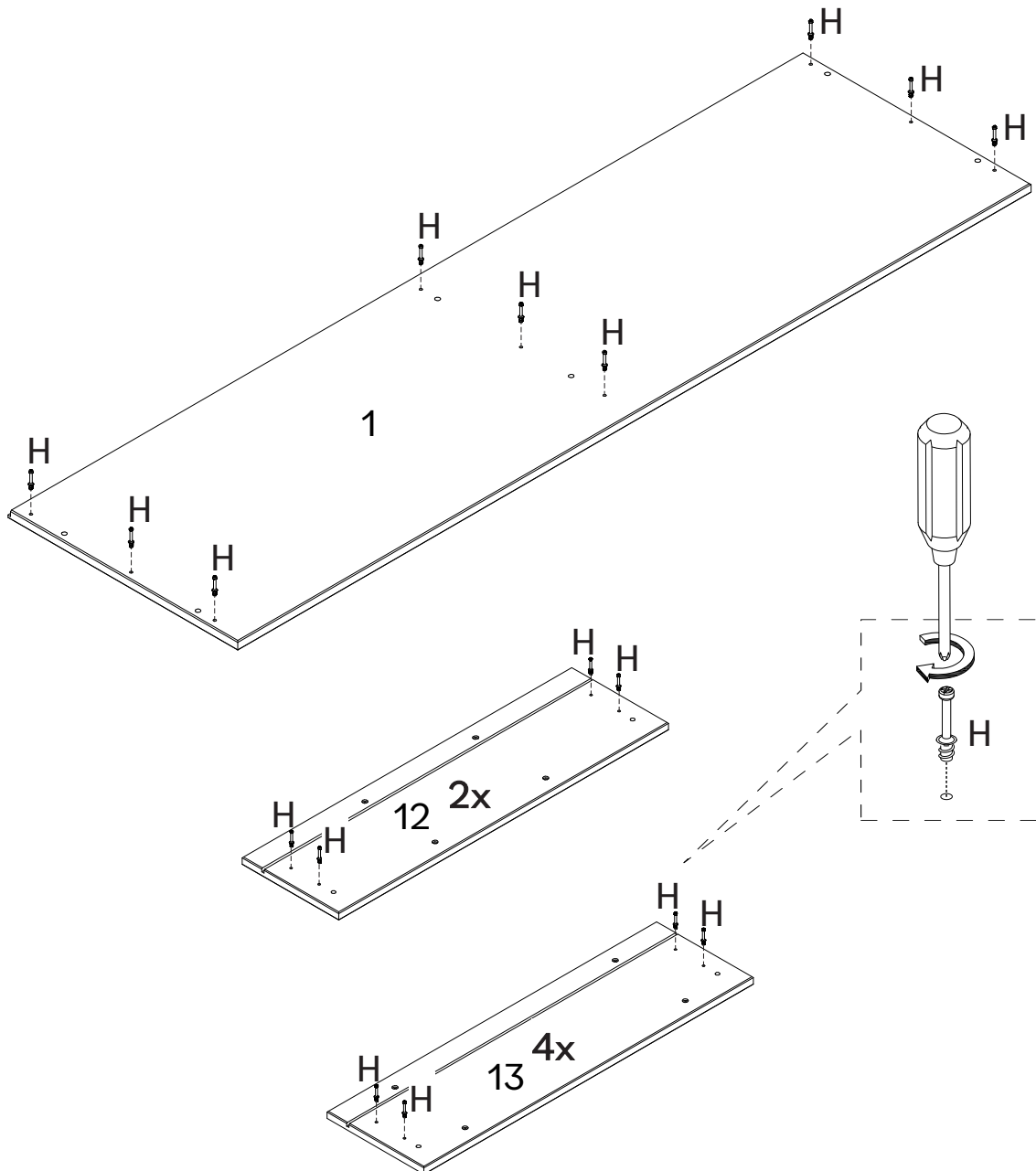
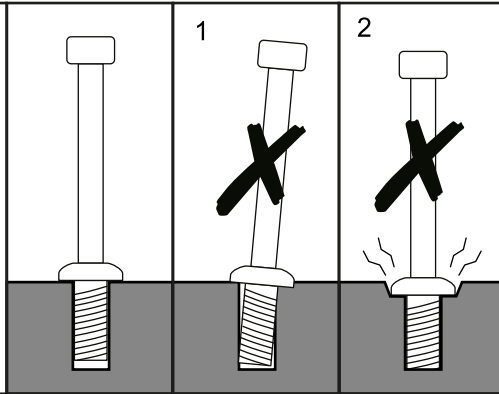

# Step 4

Secure Wood Slider (17) to Left Side Panel (2) and Right Side Panel (3) with Screw (C) and a Phillips screwdriver.

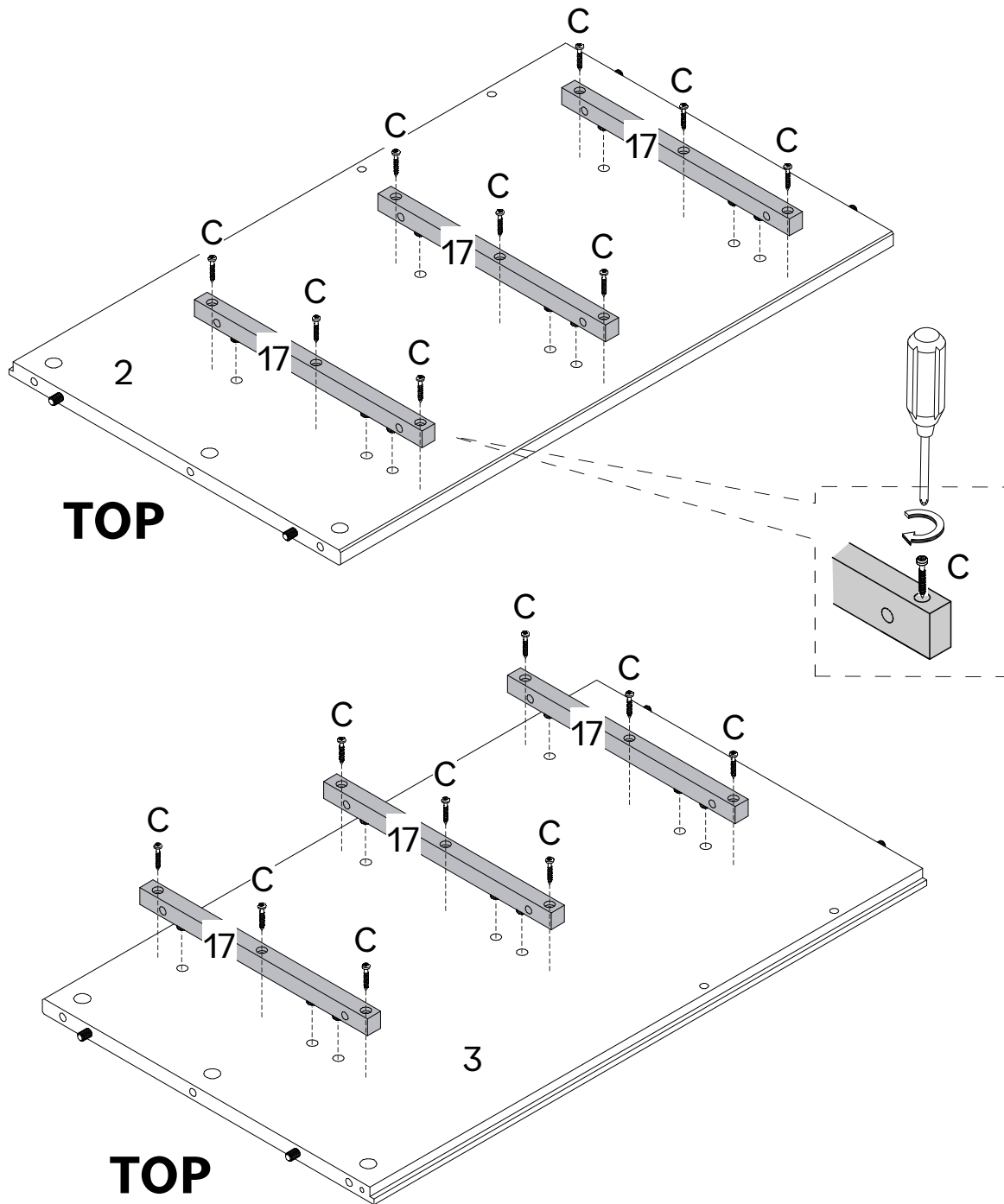



# Step 5

Secure Large Wood Slider (6) to both sides of Division (5) using Screw (C) and a Phillips head screwdriver.

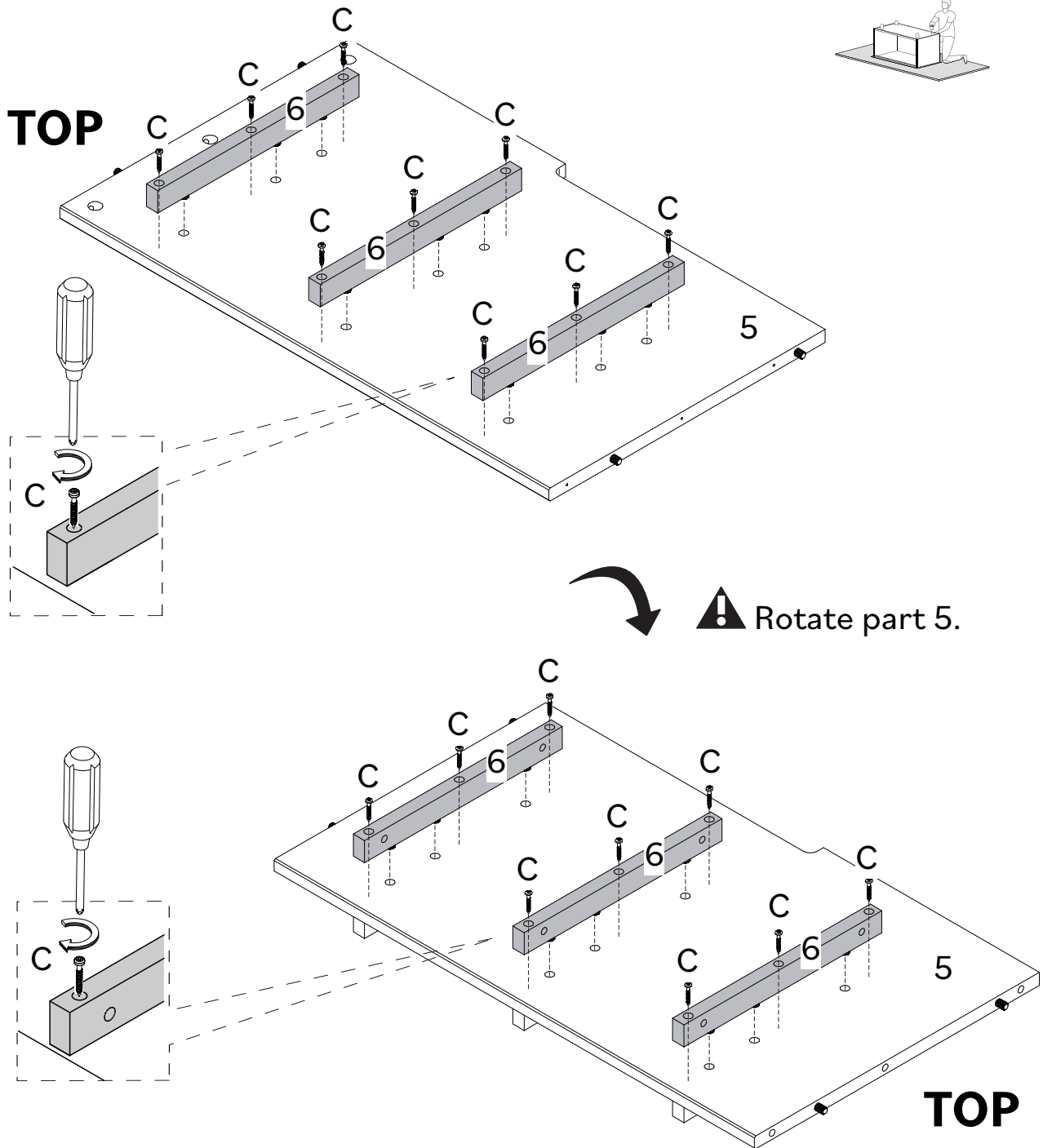

# Step 6

Secure Left Side Panel (2) and Division (5) to Top Panel (1). Insert Cam Lock (I) in Left Side Panel (2) and Division (5) and attach with a Phillips screwdriver.

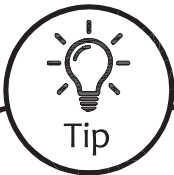
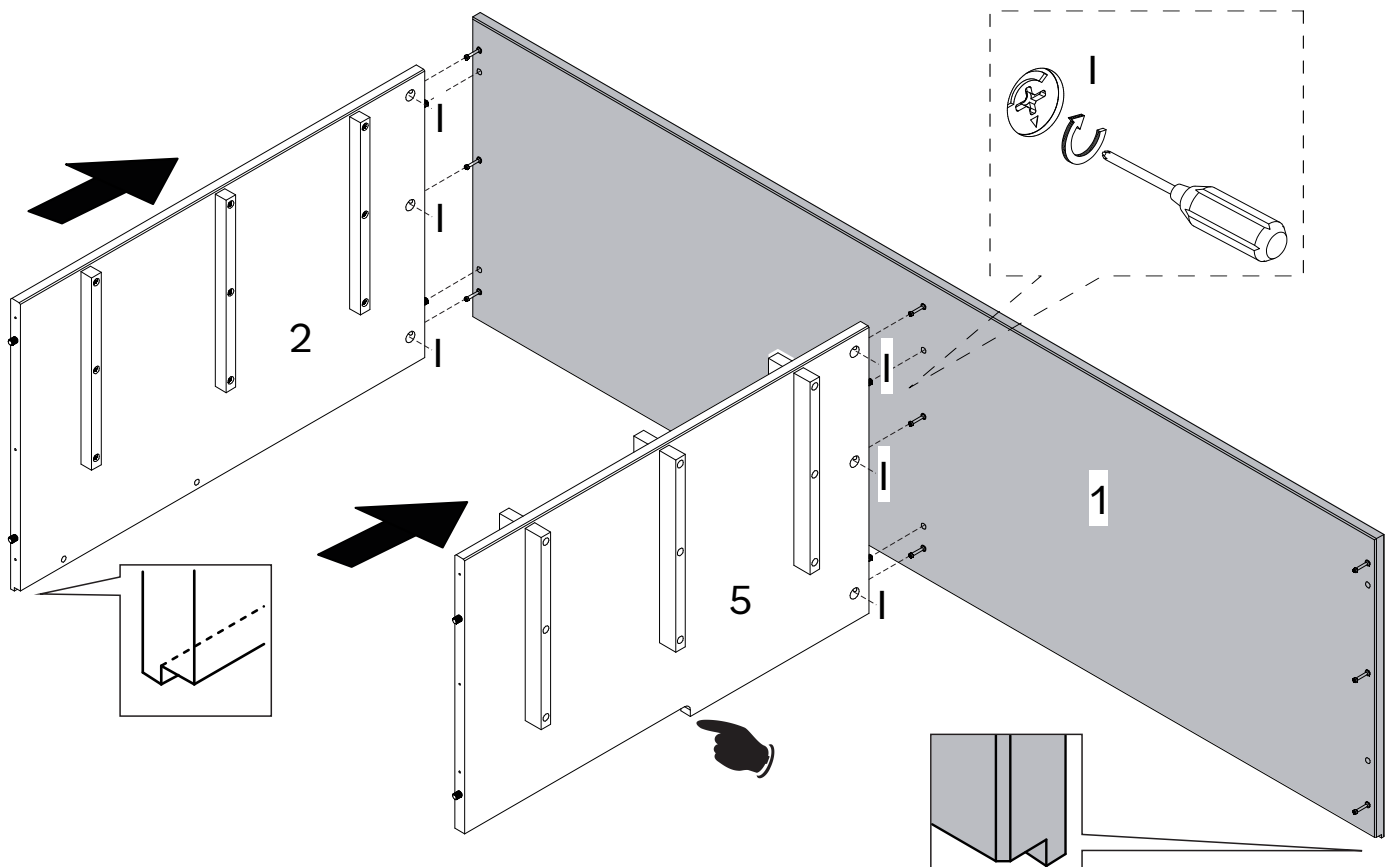

Tip

## Cam Locks

Cam Locks help securely join two pieces together.

Follow these easy steps.

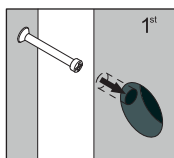

1: Insert Cam Bolt into bolt holes on the flat side. Don't over tighten

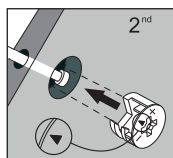

2: Fit the proper holes on the edge of the other part over the Cam Bolts. You should be able to see the cam bolts through the larger hole on the side.

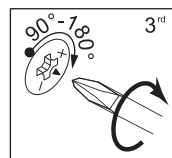

3: On the back of the Cam Lock will be a "C" shape. Insert the Cam Lock so the opening of the "C" is over the Cam Bolt. Tighten with the screwdriver.

# Step 7

Join Back Rail (8) to Left Side Panel (2).

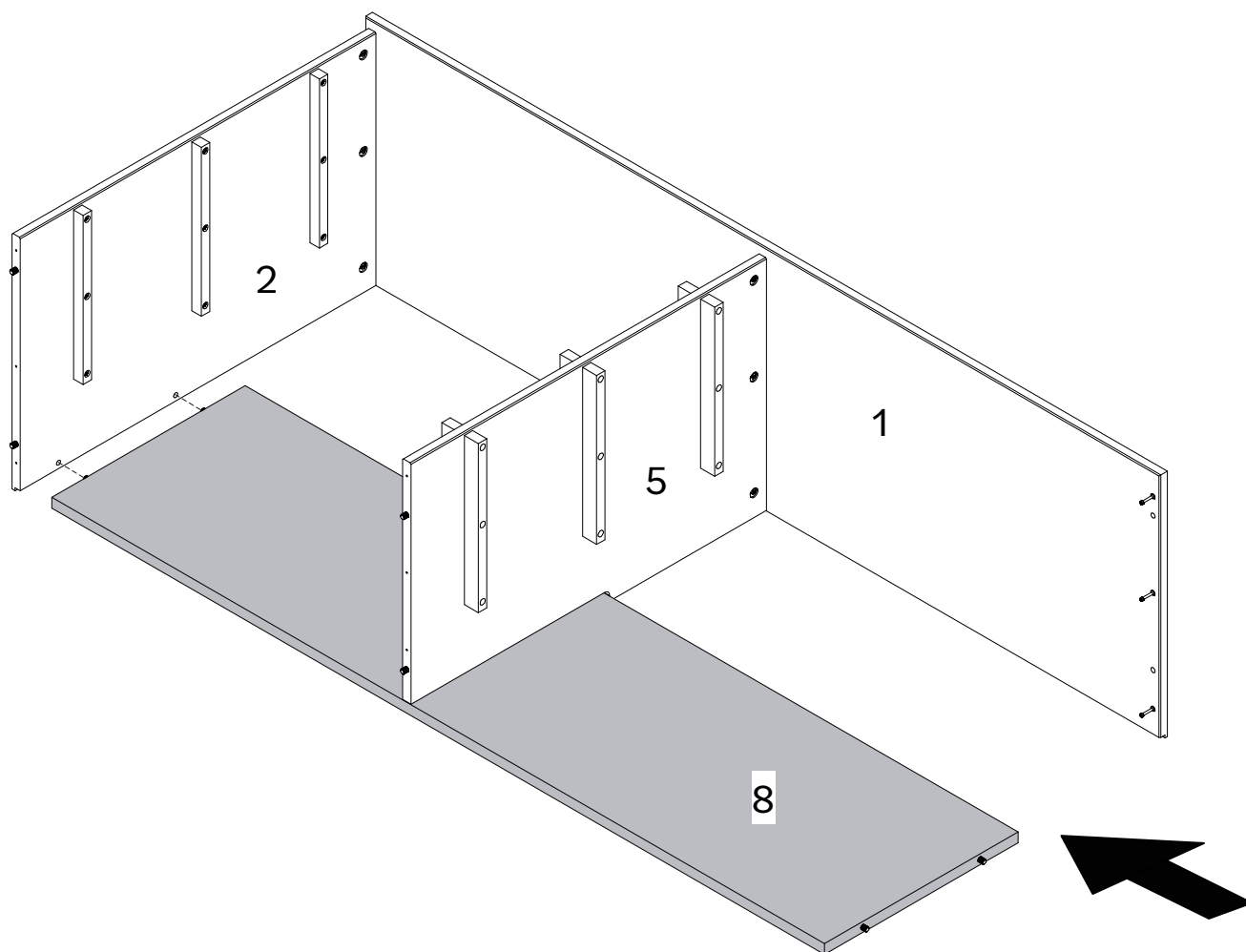
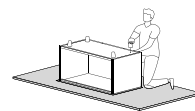

# Step 8

Join Right Side Panel (3) to Top Panel (1) and Back Rail (8).

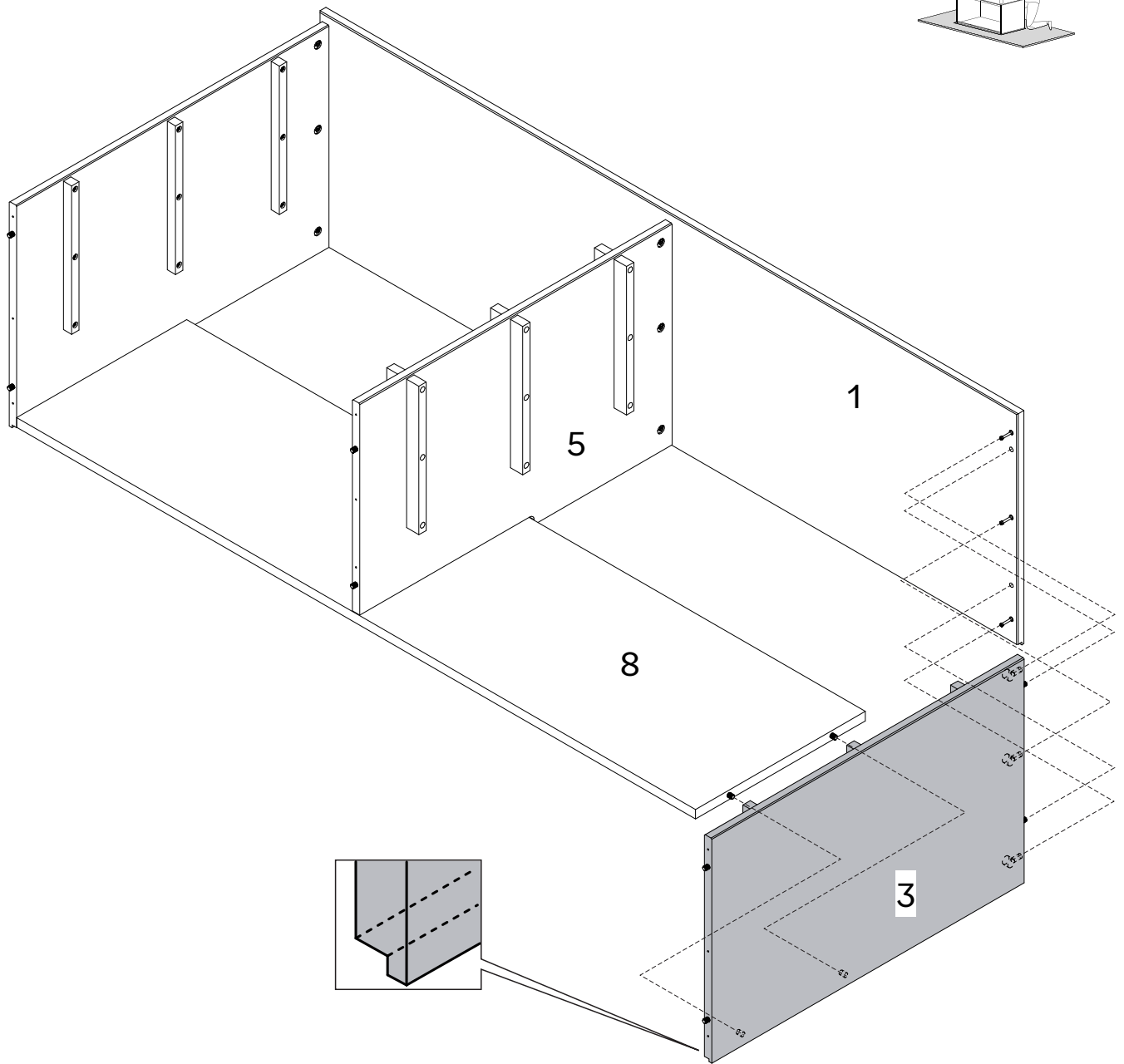

# Step 9

Insert Cam Lock (I) in Right Side Panel (3) and attach with a Phillips head screwdriver.

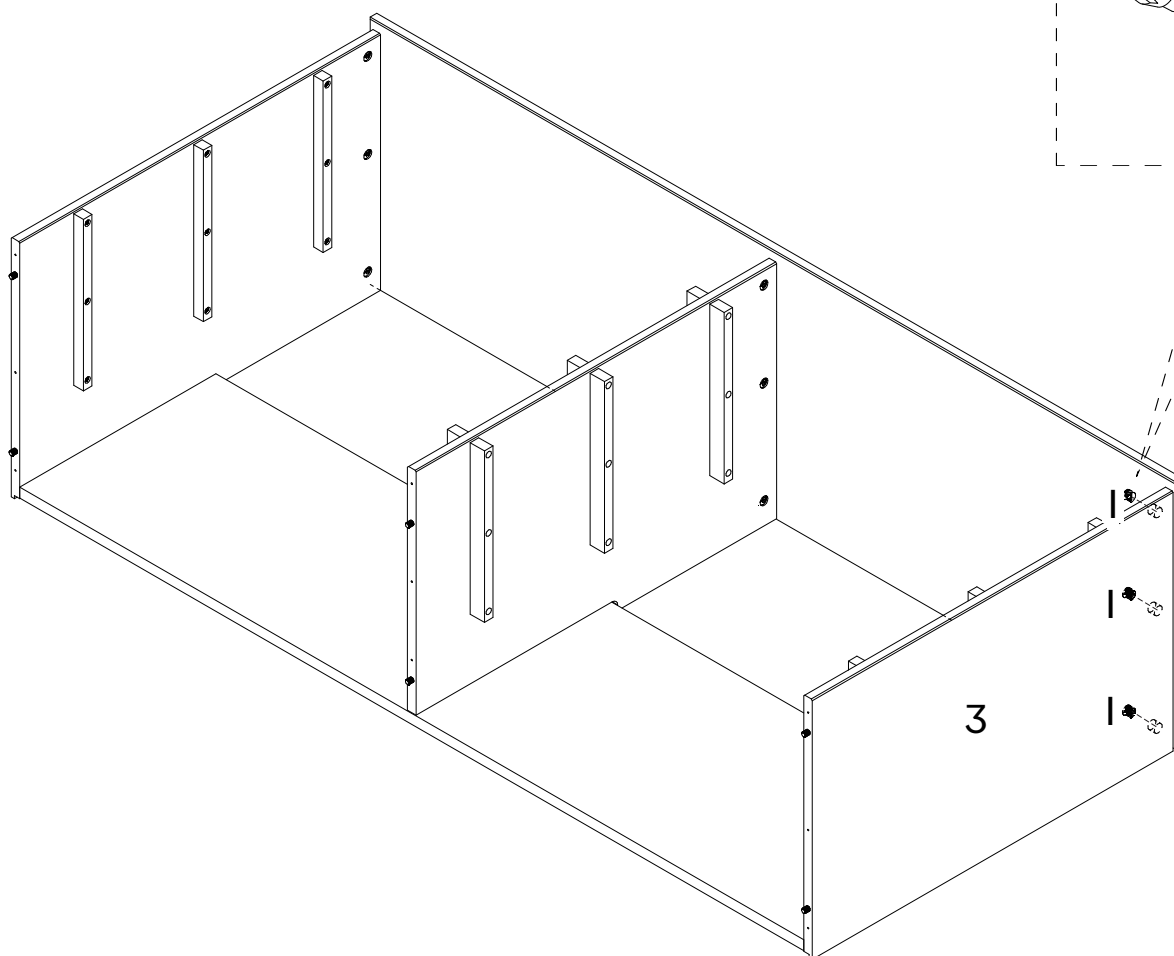
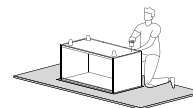
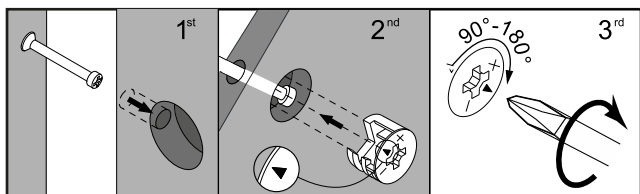

# Step 10

Insert Threaded Foot Insert (Q) into Central Foot (10) and Insert Threaded Leveling Foot (R).

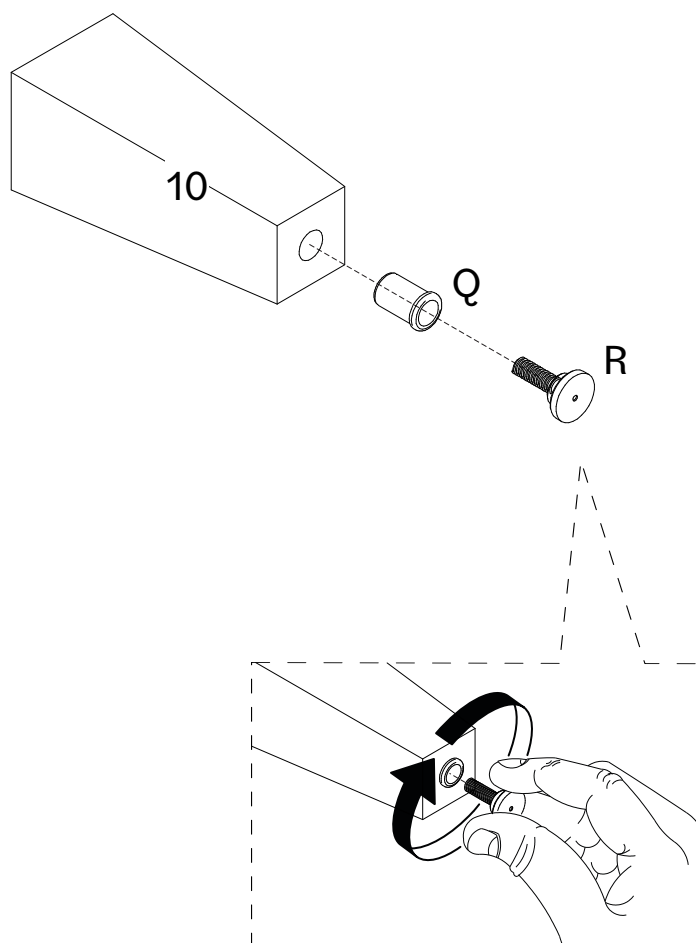
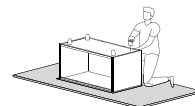

# Step 11

Secure two Feet (9), and Central Foot (10) to Bottom Panel (4) with Bolt (G) using Hex key (K).

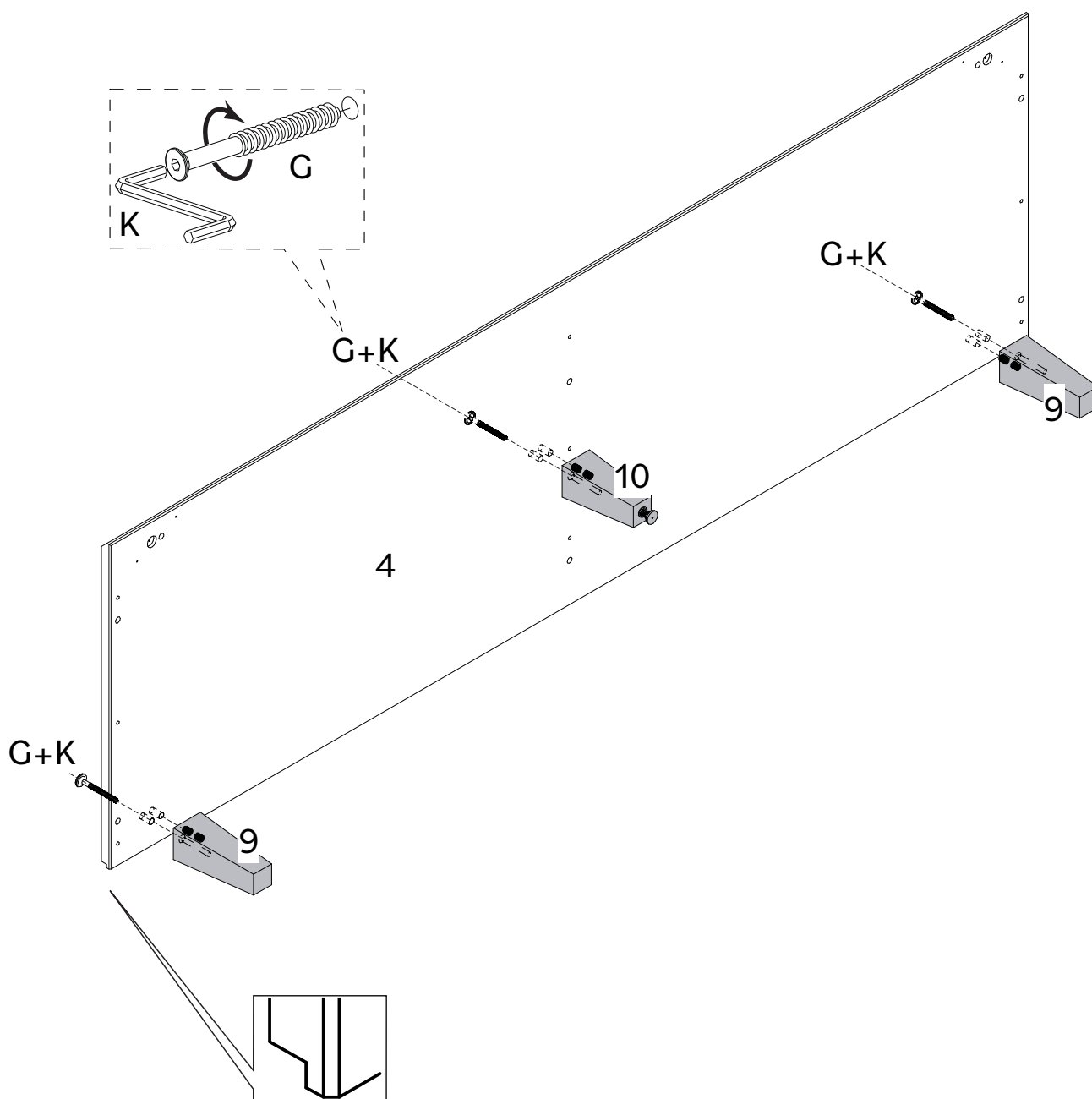
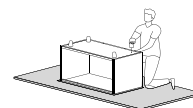

# Step 12

Attach Metal Plate (T) to the remaining Feet (9) with Bolt (S) using a Hex key (K).

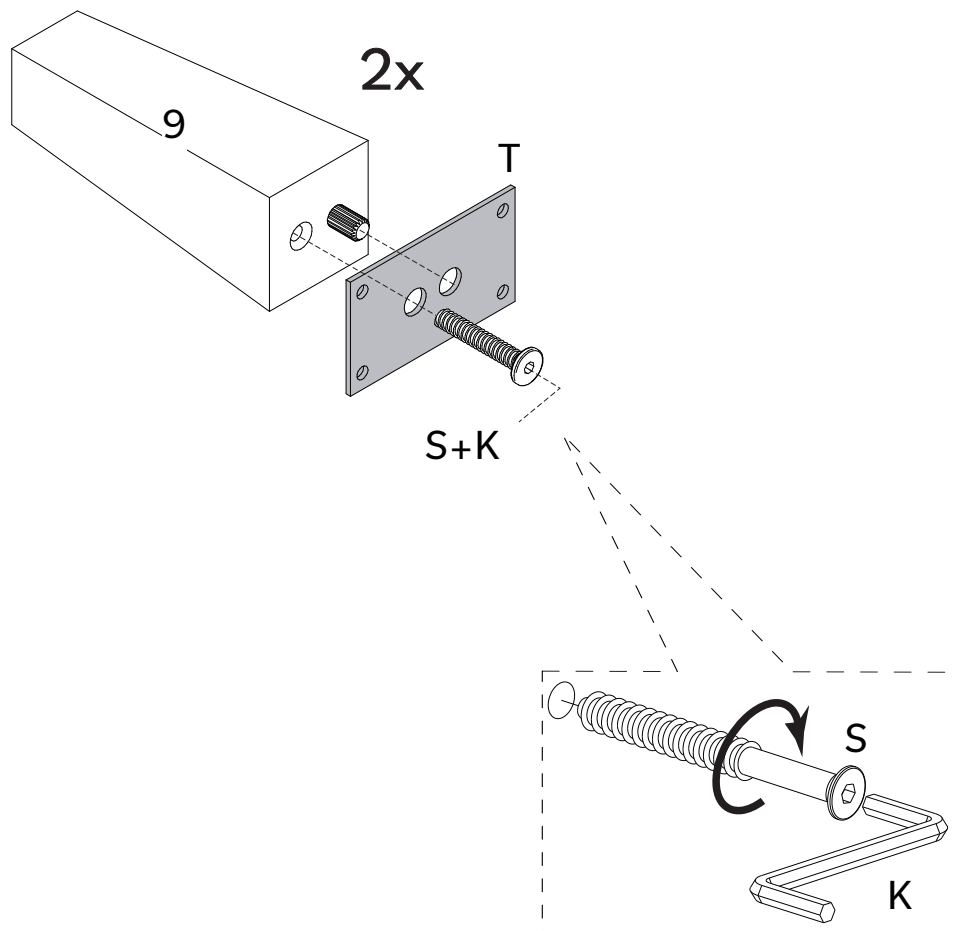
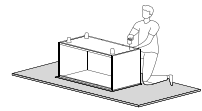



# Step 13

Secure Feet (11) to Bottom Panel (4) with Screw (N) and a Phillips head screwdriver.

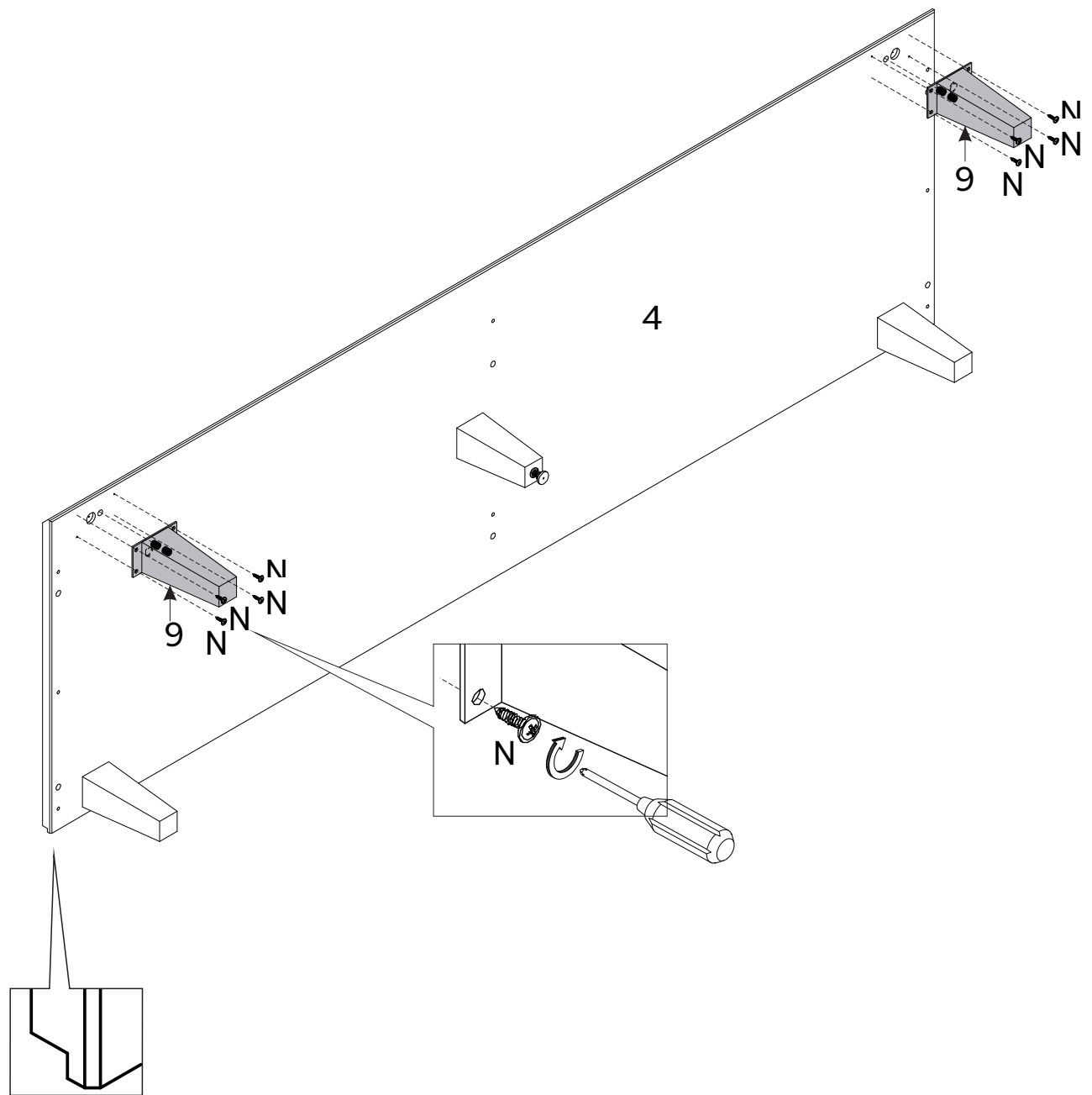
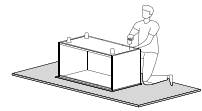

# Step 14

Attach Bottom Panel (4) to Left Side Panel (2), Division (5) and Right Side Panel (3) with Screw (E) using Phillips head screwdriver.

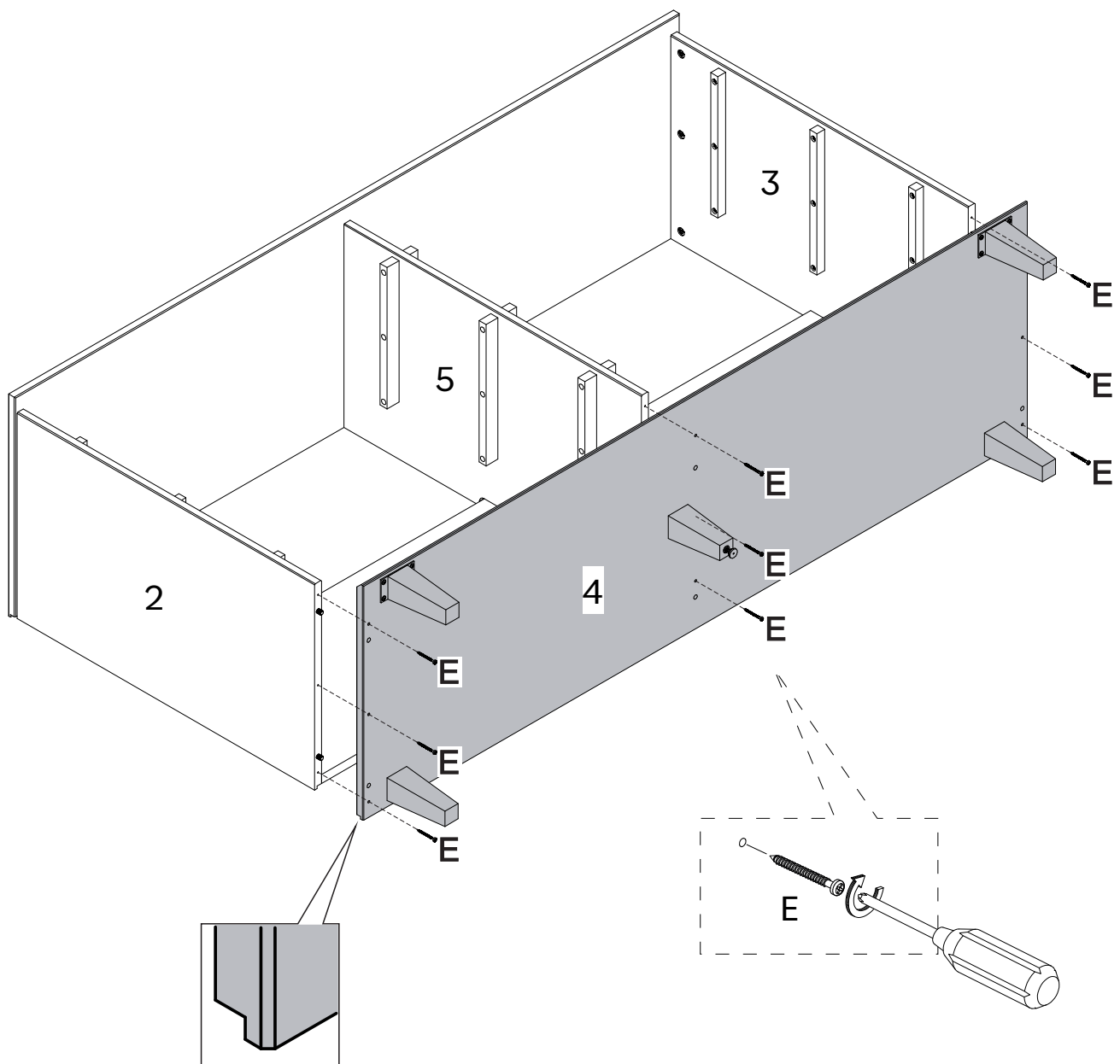
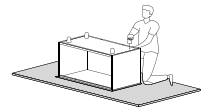

# Step 15

Secure Back Panel (7) to the dresser using Nails (F), Plate (J) and a hammer.

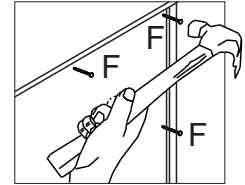

Name and address of the supplier and date of production.

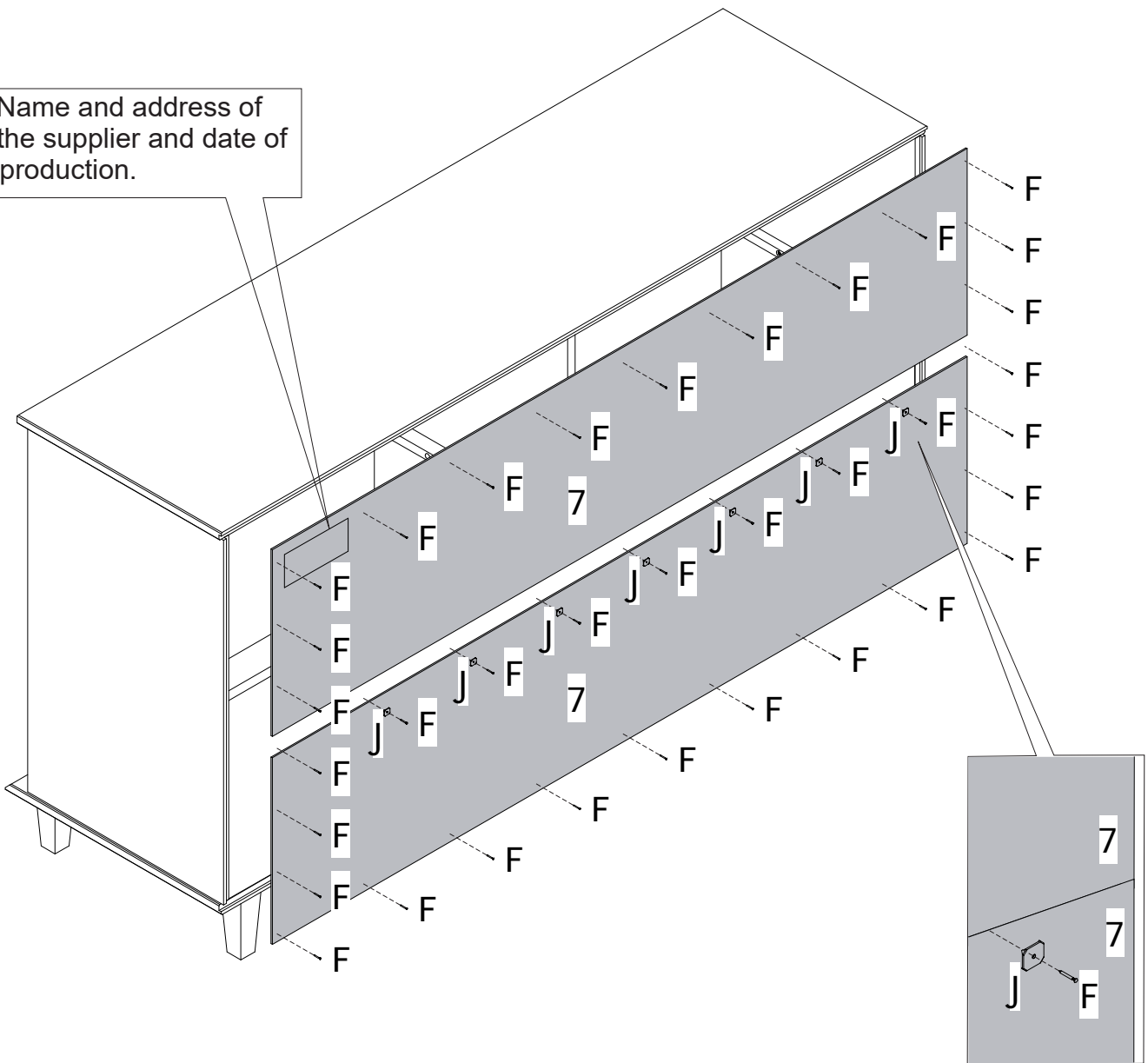

# Step 16

Insert Wooden Dowel (A) into Wood sliders (17) and Large Wood sliders (6). Also adjust the central foot to level your new dresser to the floor.

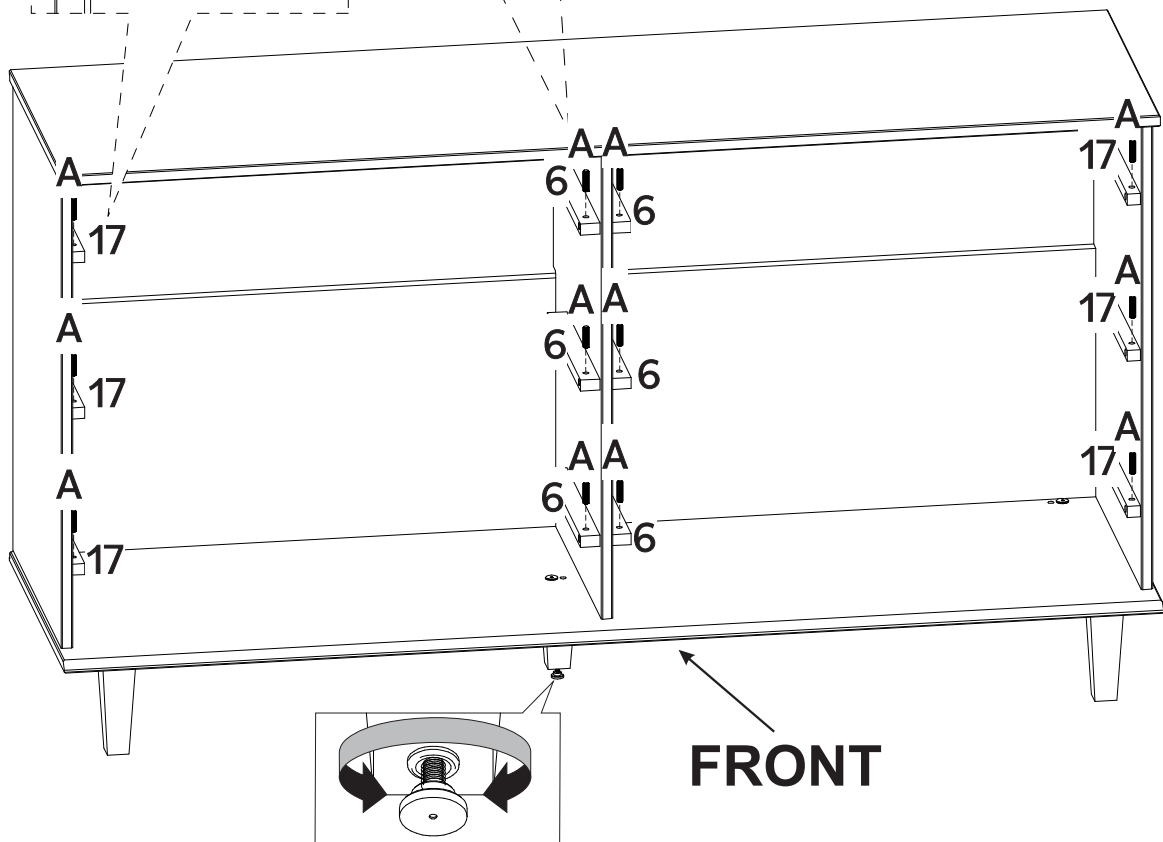
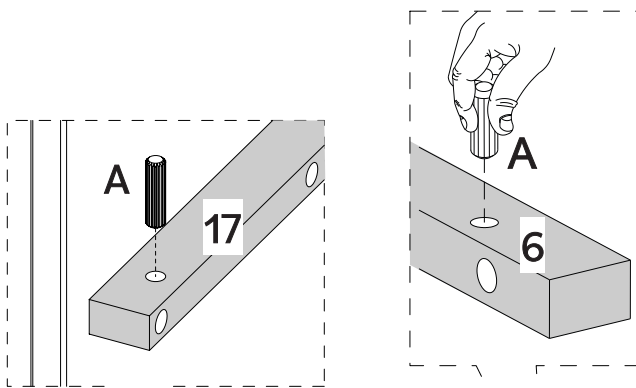
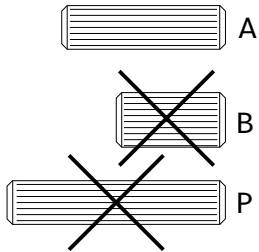

# Step 17

Attach Drawer Front (12) to Handles (11) with Screws (C) and a Phillips head screwdriver. Also, assemble Drawer Front (13) to Handles (11) with Screws (C) and a Phillips head screwdriver.

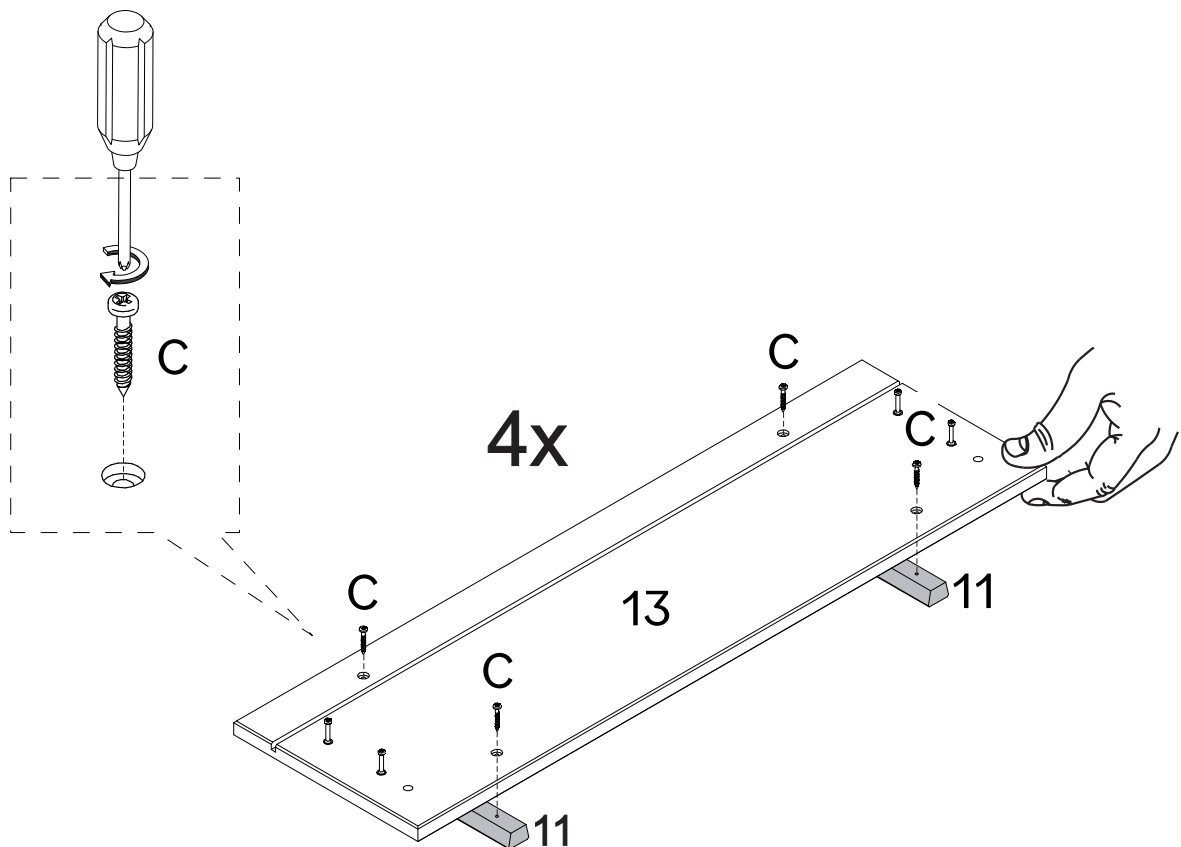
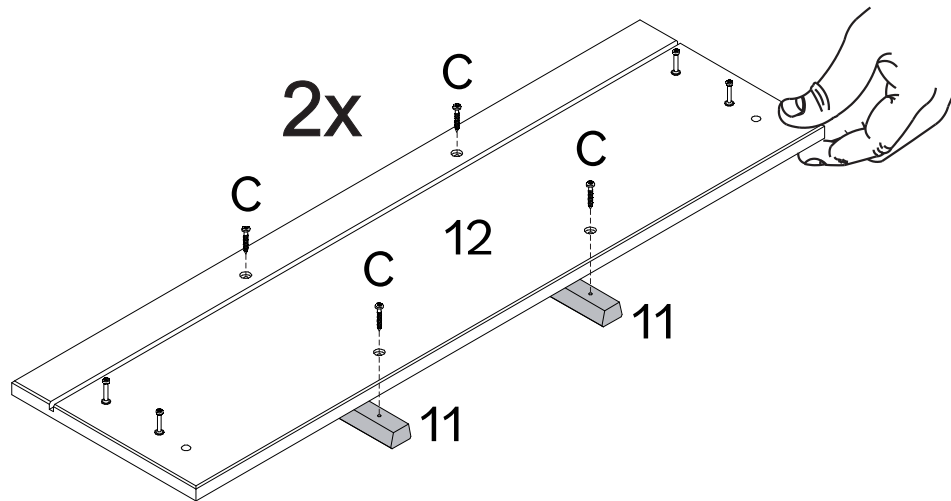
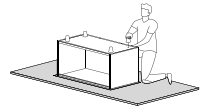

# Step 18

Secure Right Drawer Side (21) and Left Drawer Side (18) to Drawer Front (12) with Cam Lock (I) using a Phillips screwdriver. Do the same to Right drawer side (19), Left Drawer Side (18) and Drawer front (13). The last drawer type assembly is with Right Drawer Side (21) and Left Drawer Side (18) to Drawer Front (13).

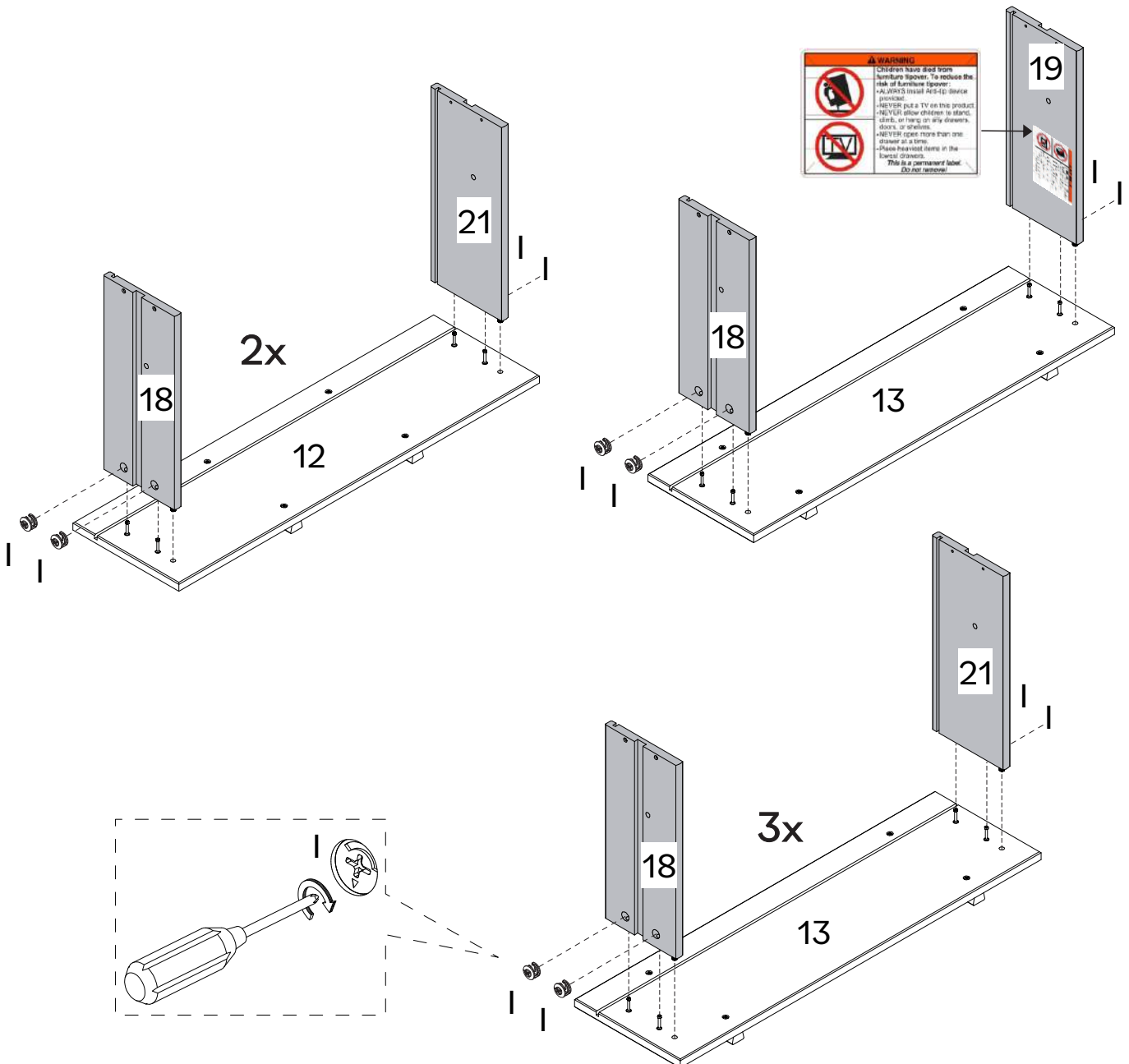
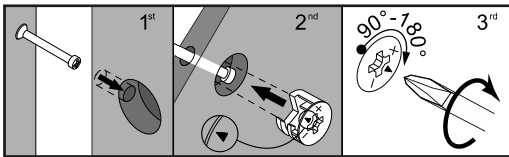

# Step 19

Slide Drawer Bottom (14) into the grooves on Left Drawer Side (18), Right Drawer Side (19) / Right Drawer Side (21), secure Drawer Back (15) with Screw (D) using a Phillips head screwdriver.

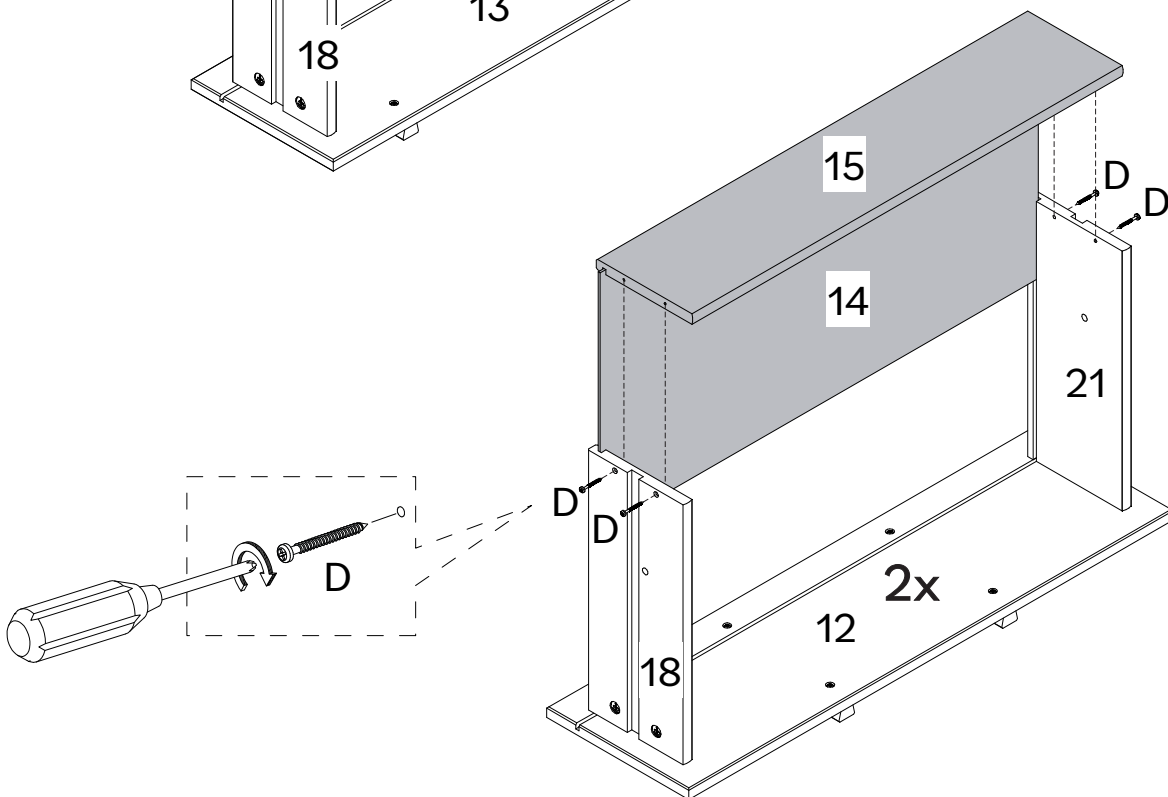
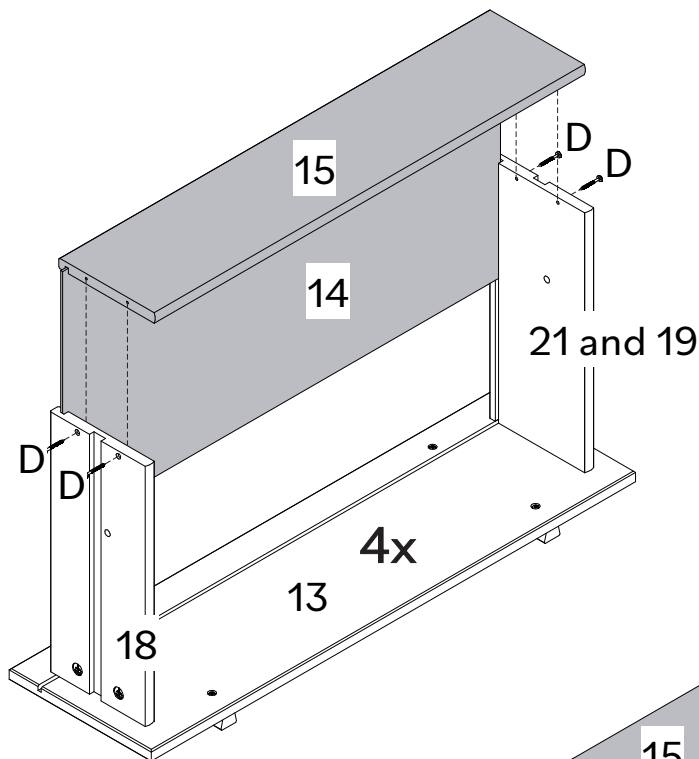

# Step 20

Insert Wooden Dowel (P) on the inside of all drawers, with the drawer inside the unit, after having passed the wooden dowel that is in the drawer slide. The dowel is not flush with the drawer side it is a little inside the drawer to help when you need to remove the lock dowel to remove the drawer.

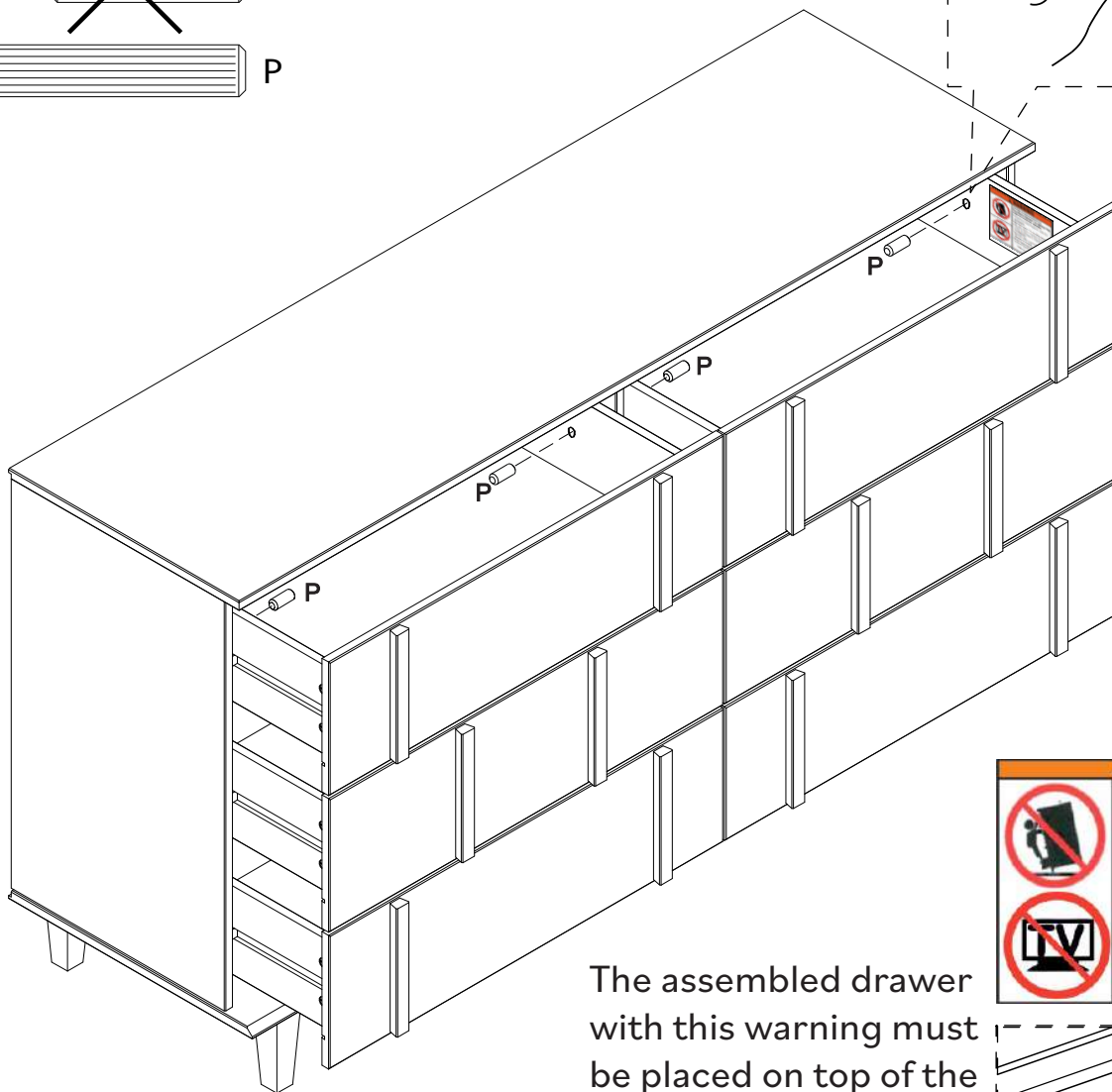
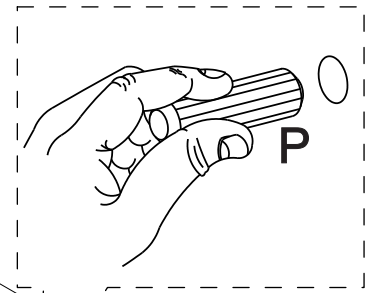
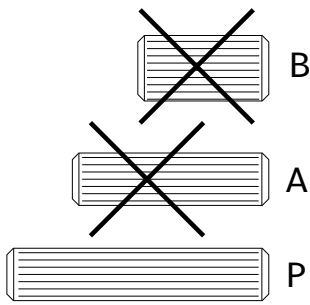

The assembled drawer with this warning must be placed on top of the unit.





# Step 21

To finish this up, let's secure your dresser to the wall! Attach the Wall Anchor (L) to your dresser using Washer (M), Screw (N) and a Phillips screwdriver.

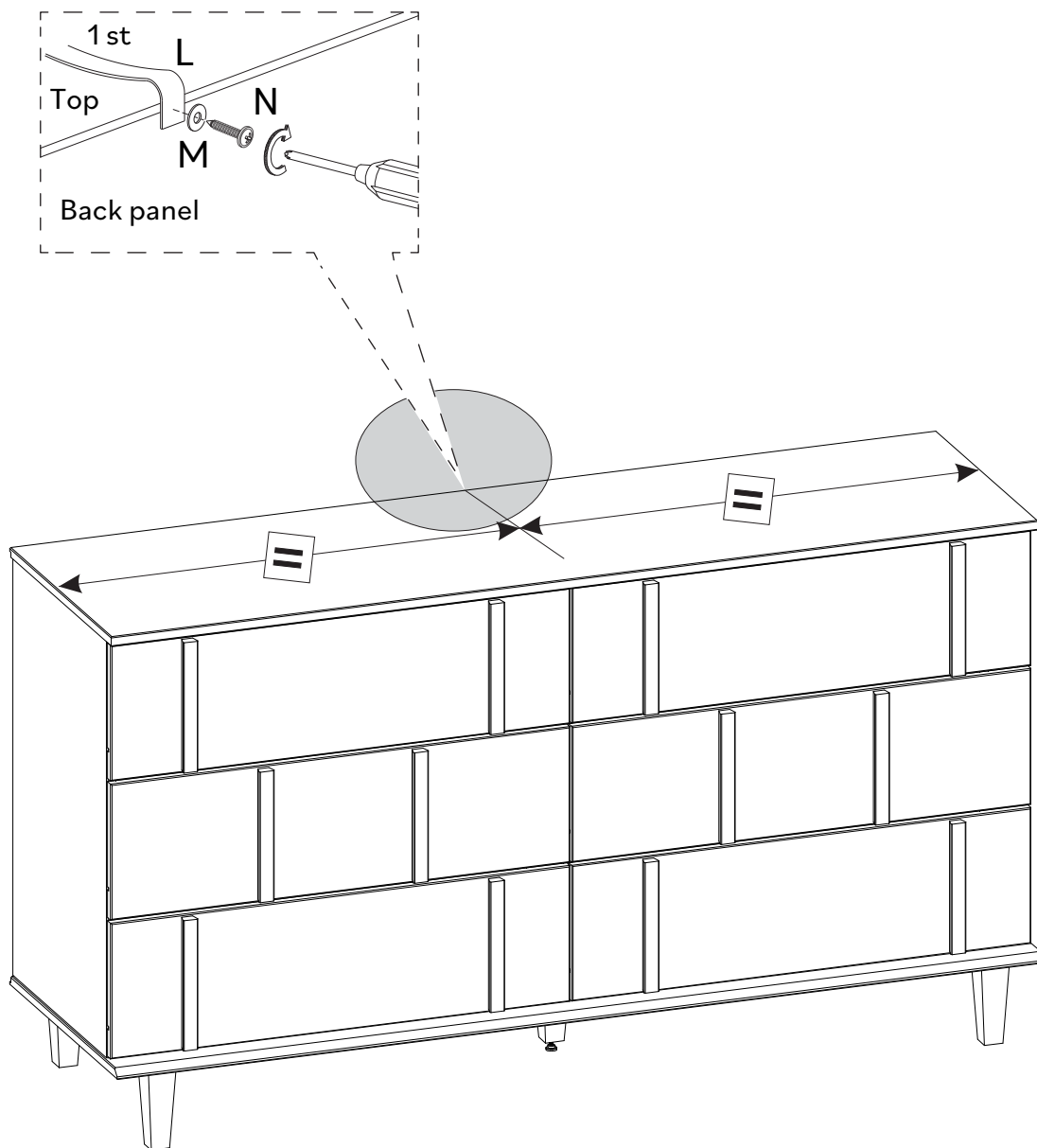

# Step 22

Insert the Plastic Bush (O) into the wall. Then, secure the Wall Anchor (L) to the wall using Washer (M) and Screw (E).

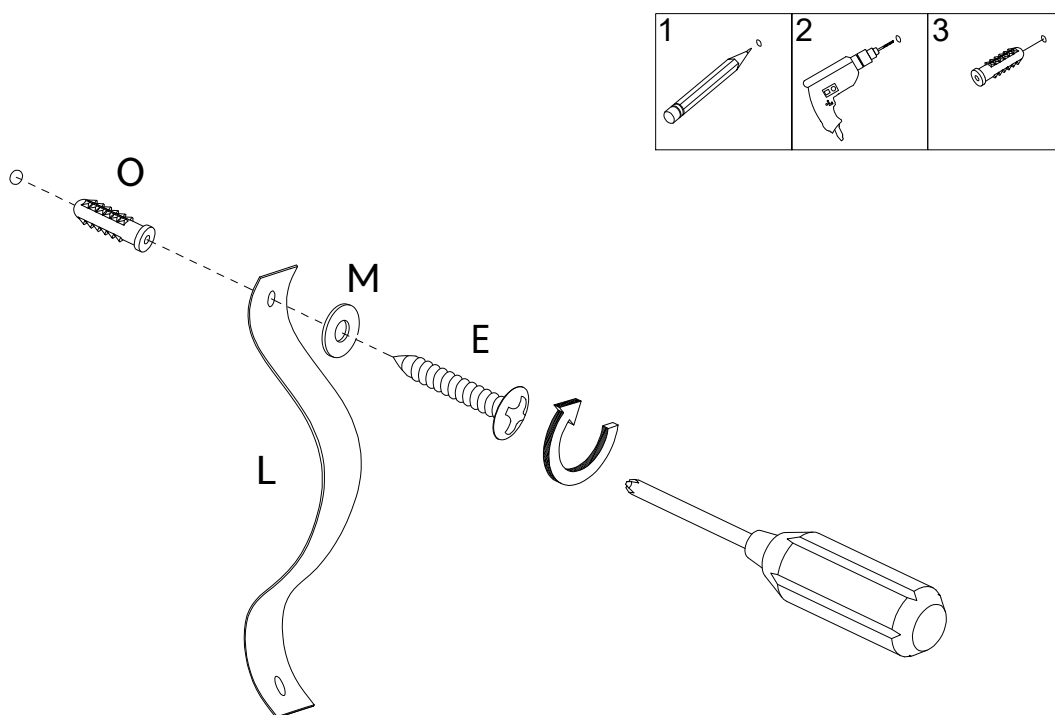

## Warning

Serious or fatal injuries can occur from furniture tipping over. To prevent the furniture from tipping over we recommend that it is permanently fixed to the wall. Wall anchor and hardware are included with this product. Please make sure hardware is suitable for your walls before installing, as different wall materials may require different types of anchors.

Name and address information for the manufacturer responsible for the anti-tip hardware and date of production can be found on the label on the back of the furniture.

You did it! Enjoy your new Dresser!

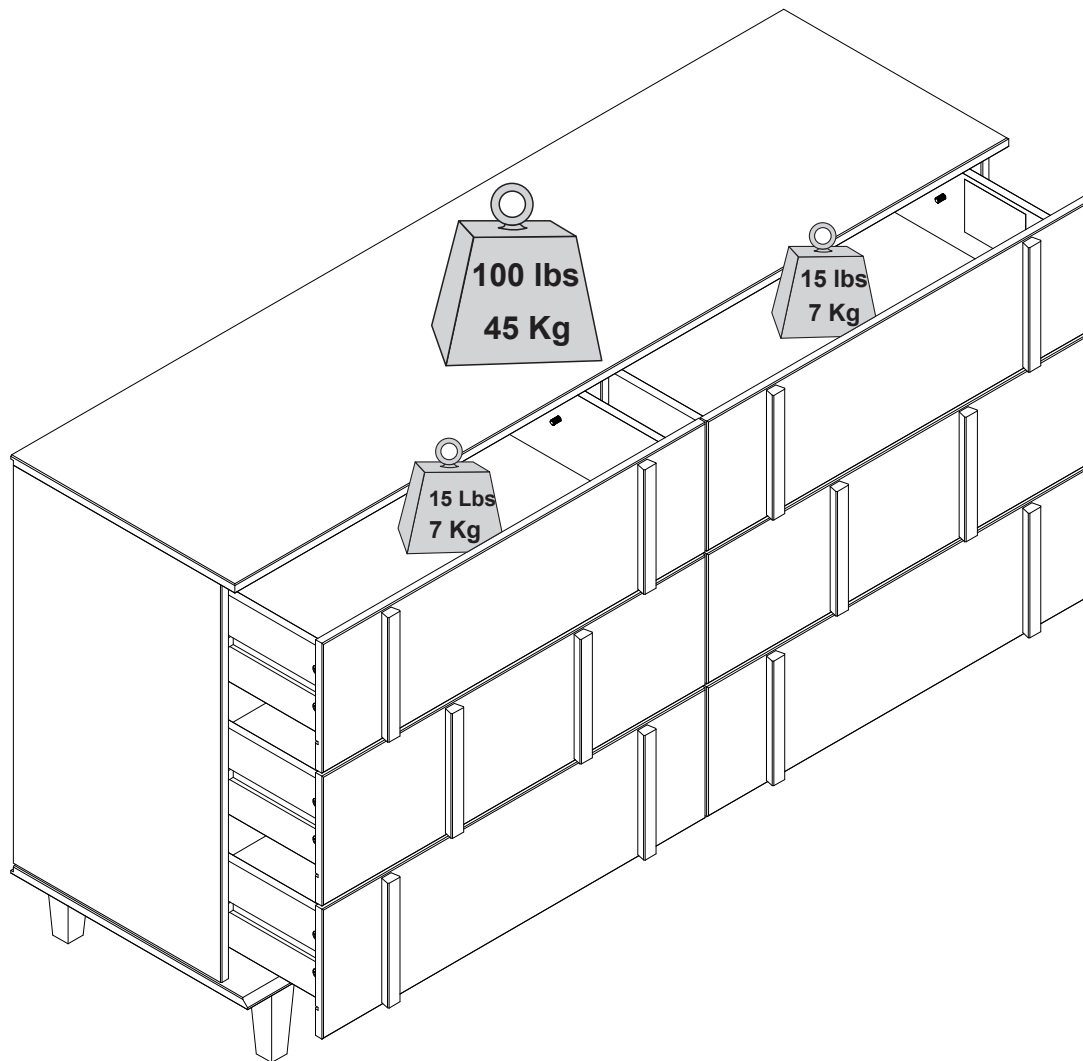

**Congratulations on your new piece of furniture!**

We would love to hear about it and see it.  
Please leave us a review or post a picture with  
**#mywalkereditonhome**

# Assembling furniture can be tricky sometimes.

Our customer service team, located in Utah, is here for product information, help assembling a product, or for any other customer support issue

Call us at **801-433-3008**

Email us at [service@walkeredison.com](mailto:service@walkeredison.com)

Visit our Customer Service website at  
[walkeredison.com/pages/customer-service](http://walkeredison.com/pages/customer-service)

We are available to help Monday -Thursday 8am-5pm, Friday 8am-3pm MST

For details on Assembly Videos, Assembly Instructions, Replacement Parts, and Customer service,

**SCAN HERE**



For cleaning, never use abrasives, use a soft cloth and water with neutral soap to clean the furniture.

# WALKER EDISON™

Bronx Commode moderne  
en bois massif  
Bronx Cómoda moderna de  
madera maciza

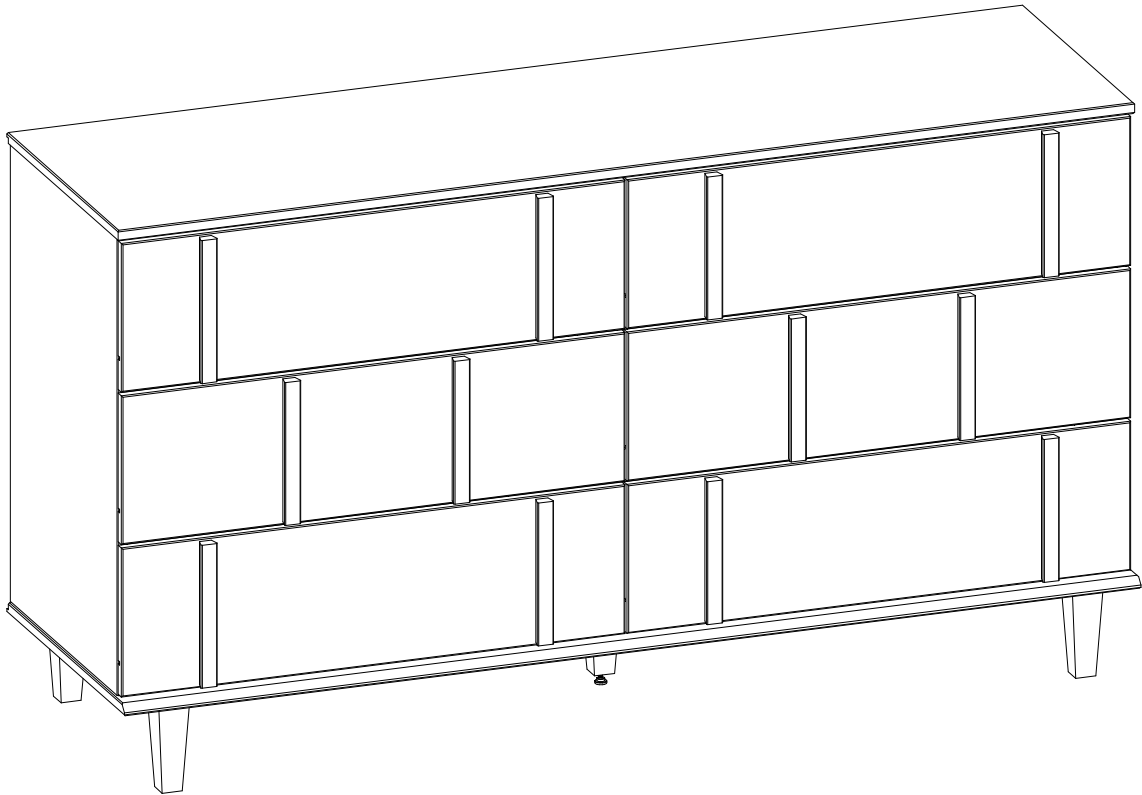

**Pour usage résidentiel seulement**

Visite notre site Web pour obtenir les instructions les plus récentes, des conseils d'assemblage, signaler des dommages ou commander des pièces. [www.walkeredison.com](http://www.walkeredison.com)

**Sólo para uso residencial**

Visite nuestro sitio web para consultar las últimas instrucciones, consejos de montaje, notificar daños o solicitar piezas. [www.walkeredison.com](http://www.walkeredison.com)

# WE Il est temps de commencer / Hora de empezar

Prépare un lieu de travail propre et souple pour éviter tout dommage lors de l'assemblage. Tu peux utiliser la boîte et les protections internes comme base. Vérifie également que tu disposes de toutes les pièces et parties avant de te lancer dans l'assemblage.

Prepare un lugar de trabajo limpio y blando para evitar daños durante el montaje. Puede utilizar la caja y las protecciones internas como base. Comprueba también que tiene todas las piezas y partes antes de sumergirse en el montaje.

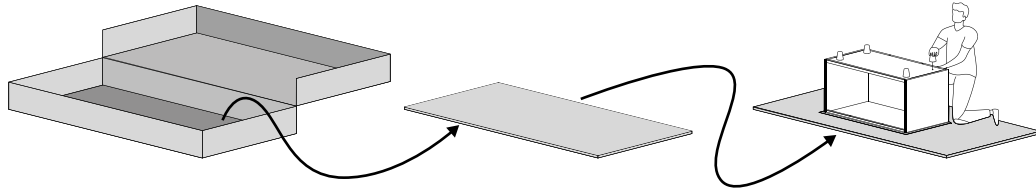

**Temps de montage  
estimé**

**Tiempo estimado  
de montaje**

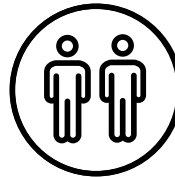

2 People Build

**Personnes recommandées  
pour le montage**

Fais-en un effort d'équipe !  
Appelle un ami pour un assemblage  
plus rapide et plus facile.

**Personas recomendadas  
para el montaje**

¡Hágalo en equipo!  
Llame a un amigo para que el montaje  
sea más rápido y sencillo.

## Outils nécessaires

Munis-toi d'un tournevis cruciforme et marteau pour réaliser cet assemblage.

## Herramientas requeridas

Tome un destornillador Phillips y martillo para conquistar este montaje.

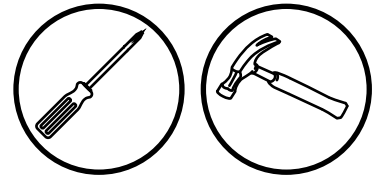

## Utilise les outils électriques avec précaution

Ce meuble est réalisé en Bois Massif et Bois Composite, des matériaux souples. Si tu choisis d'utiliser des outils électriques, règle-les sur le mode le plus lent. Fais attention à toi ! Les outils électriques peuvent provoquer des fissures ou endommager les meubles, mais aussi les autres composants s'ils sont mal utilisés. Les dommages causés par un outil électrique ne sont pas couverts par la garantie Walker Edison.

## Utilice las herramientas eléctricas con cuidado.

Este mueble está fabricado con madera maciza y madera compuesta, materiales blandos. Si decide utilizar herramientas eléctricas, ajústelas al ajuste más lento. Tenga cuidado. Las herramientas eléctricas pueden causar grietas o daños en el mueble, pero también en los herrajes si se utilizan mal. Los daños causados por una herramienta eléctrica no están cubiertos por la garantía de Walker Edison.

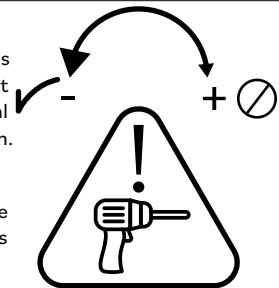

## Attention avec la glissière

Tes meubles possèdent des glissières en bois très résistantes. De temps en temps, nous recommandons d'appliquer de la paraffine ou de la cire de bougie standard pour améliorer la glisse des curseurs.

## Cuidado con las guías

Tus muebles cuentan con guías de madera de alta durabilidad. De vez en cuando, recomendamos la

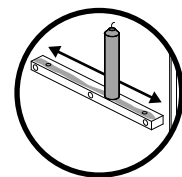

**Scannez pour obtenir des conseils d'assemblage et de l'aide !  
¡Escanee para obtener consejos de montaje y ayuda!**



# Liste de pièces / Lista de piezas

Nombre de pièces Número de pieza	Description Descripción	Quantité Cantidad
1	Panneau Supérieur Panel Superior	1
2	Panneau Gauche Panel Izquierdo	1
3	Panneau Droit Panel Derecho	1
4	Panneau Inférieur Panel Inferior	1
5	Panneau Central Panel Central	1
6	Glissière Large Correderas Largas	6
7	Panneau Arrière Panel Trasero	2
8	Panneau Arrière Inférieur Panel Trasero Inferior	1
9	Pied Pie	4
10	Pied Central Pie Central	1

Nombre de pièces Número de pieza	Description Descripción	Quantité Cantidad
11	Poignée Manija	12
12	Façade du Tiroir Central Frente del Cajón Central	2
13	Façade du Tiroir Frente del Cajón	4
14	Fond du Tiroir Inferior del Cajón	6
15	Arrière du Tiroir Trasero del Cajón	6
17	Glissière Corredera	6
18	Côté Gauche du Tiroir Lado Izquierdo del Cajón	6
19	Côté Gauche du Tiroir (Avertissement) Lado Derecho del Cajón (Advertencia)	1
21	Côté Gauche du Tiroir Lado Derecho del Cajón	5

WALKER EDISON  
Distribution and responsible for the anti-tip hardware:  
Walker Edison Furniture Company  
1553 W 9000 S, West Jordan, UT 84088 United States

Collection Name  
**QR COD.**

Model: XXXXXXXXFF  
LOT: AYYWW-XXXX  
Date: MM/20YY  
Rev. MM/20YY-VX

CANFER compliant / conforme au CANFER  
TSCA Title VI compliant / conforme au titre VI de la TSCA  
California 93120 Compliant for Formaldehyde / Conforme à la norme Californie 93120 pour le formaldéhyde.

For details on Assembly Videos, Assembly Instructions, Replacement Parts and Customer Service. SCAN HERE.

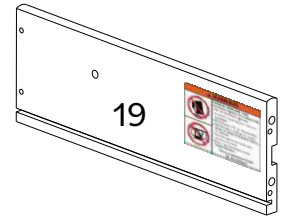

Le côté droit du tiroir avec l'étiquette doit être monté sur le tiroir supérieur.

El lado derecho del cajón con etiqueta debe montarse en el cajón superior.

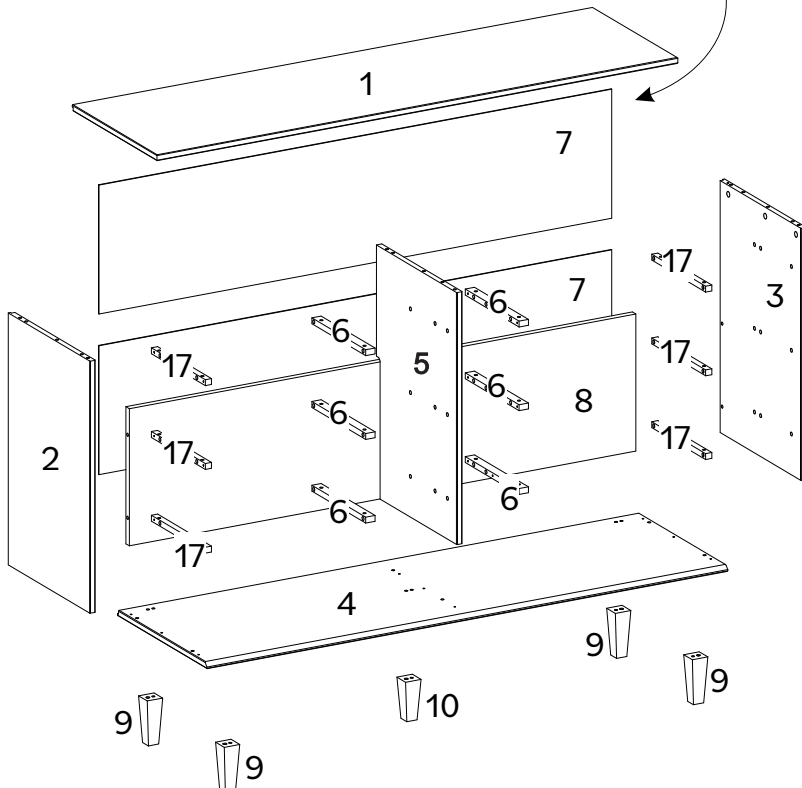

**WARNING**







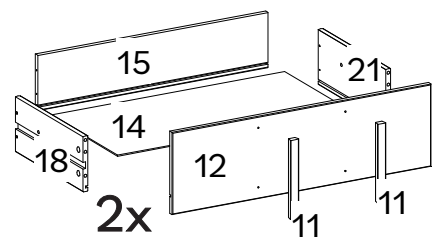
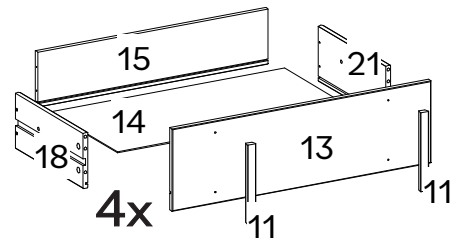



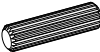





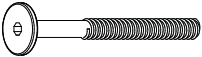
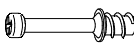

Children have died from furniture tipover. To reduce the risk of furniture tipover:

- ALWAYS install tipover restraint provided.
- NEVER put a TV on this product.
- NEVER allow children to stand, climb or hang on any drawers, doors, or shelves.
- Never open more than one drawer at a time.
- Place heaviest items in the lowest drawers.

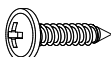
This is a permanent label. Do not remove!

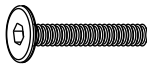

# Liste de composants / Lista de hardware

Partie Parte	Taille Tamaño	Nom Nombre	Quantité Cantidad
A	 8x30mm	Cheville Espiga	45
B	 10x20mm	Cheville Espiga	36
C	 4x25mm	Vis Tornillo	60
D	 3,5x30mm	Vis Tornillo	24
E	 4,0x40mm	Vis Tornillo	10
F	 10x7	Clou Clavo	35
G	 7x60mm	Boulon Perno	03
H	 6x31mm	Goujoun Conector	33
I	 15x12mm	Boitier Traba del Conector	33
J	 15x15mm	Plaque Placa	07
K	 4mm	Clé Hexagonale Llave Hexagonal	01
L		Rubán Cinta	01
M		Rondelle Arandela	02
N	 4x14mm	Vis Tornillo	09
O	 6x35mm	Douille Casquillo	01
P	 8x40mm	Cheville Espiga	12
Q		Douille du Pied Casquillo del Pie	01
R	 1/4x25mm	Pied de Nivellement Zapata Niveladora	01
S	 7x40mm	Boulon Perno	02
T	 75x50mm	Plate metalique Placa metálica	02

*Les quantités de composants indiquées ci-dessus sont nécessaires pour un assemblage correct.  
Des pièces supplémentaires peuvent être incluses.*

*Las cantidades de tornillería indicadas anteriormente son necesarias para un montaje correcto.  
Se pueden incluir piezas de ferretería adicionales.*



# Étape / Paso 1

(FR)

C'est parti ! Insérez les Chevilles (B) dans les Glissières Larges (6) et les Glissières (17).

(ESP)

¡Empecemos! Inserte las Espigas (B) en las Correderas Largas (6) y las Correderas (17)

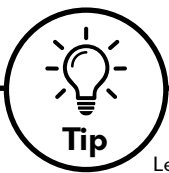
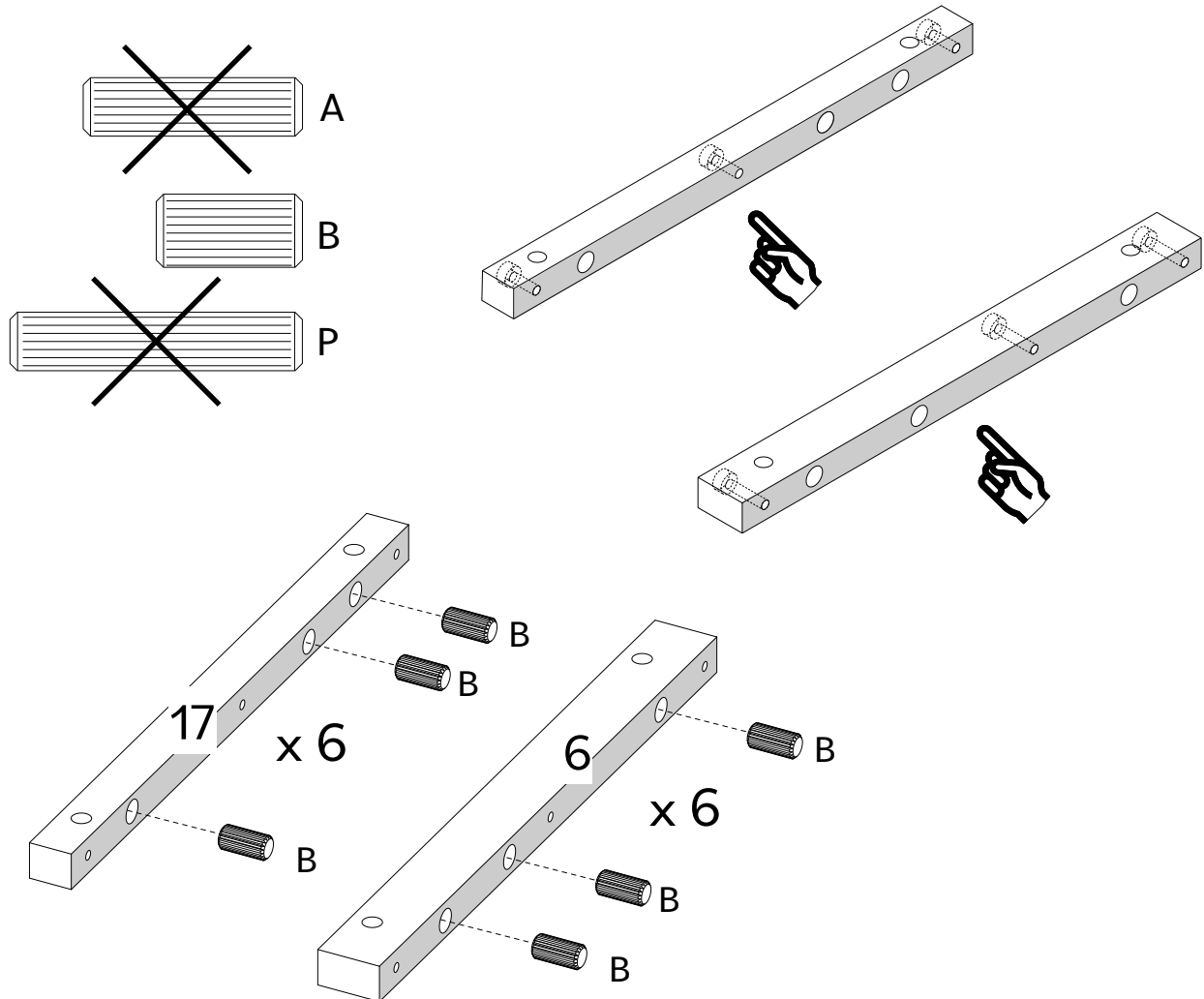

Tip

## Cheville en bois

Les chevilles sont essentielles lors de l'assemblage de meubles pour créer des connexions solides et précises. Elles garantissent l'intégrité structurelle, empêchent les déplacements et simplifient l'alignement, ce qui permet d'obtenir des meubles plus résistants et plus durables. suis ces étapes :

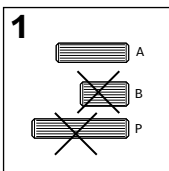

- 1: Sélectionne la taille de cheville appropriée en fonction de l'étape.
- 1: Seleccione el tamaño de espiga adecuado según el paso.

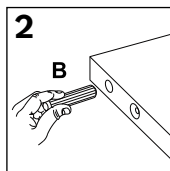

- 2: Insère dans le trou indiqué et appuie fermement pour assurer un positionnement correct.
- 2: Insértela en el orificio indicado y presione firmemente para asegurar su correcta colocación.

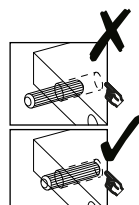

Sigue estos pasos:

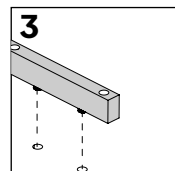

- 3: Alinee la cheville avec la pièce correspondante et enfonce-la jusqu'à ce qu'elle soit ferme.
- 3: Alinee el pasador con la pieza correspondiente y presiónelo hasta que encaje.

# Étape / Paso 2

(FR)

Insérez les Chevilles (A) dans le Panneau Gauche (2), Panneau Droit (3), Panneau Central (5), Panneau Arrière Inférieur (8), Pied (9), Pied Central (10), Côté Gauche du Troir (18), Côté Droit du Tiroir (Avertissement) (19) et Côté Droit du Tiroir (21).

(ESP)

Inserte las Espigas (A) en el Panel Izquierdo (2), Panel Derecho (3), Panel Central (5), Panel Trasero Inferior (8), Pie (9), Pie Central (10), Lado Izquierdo del Cajón (18), Lado Derecho del Cajón (Advertencia) (19) y Lado Derecho del Cajón (21).

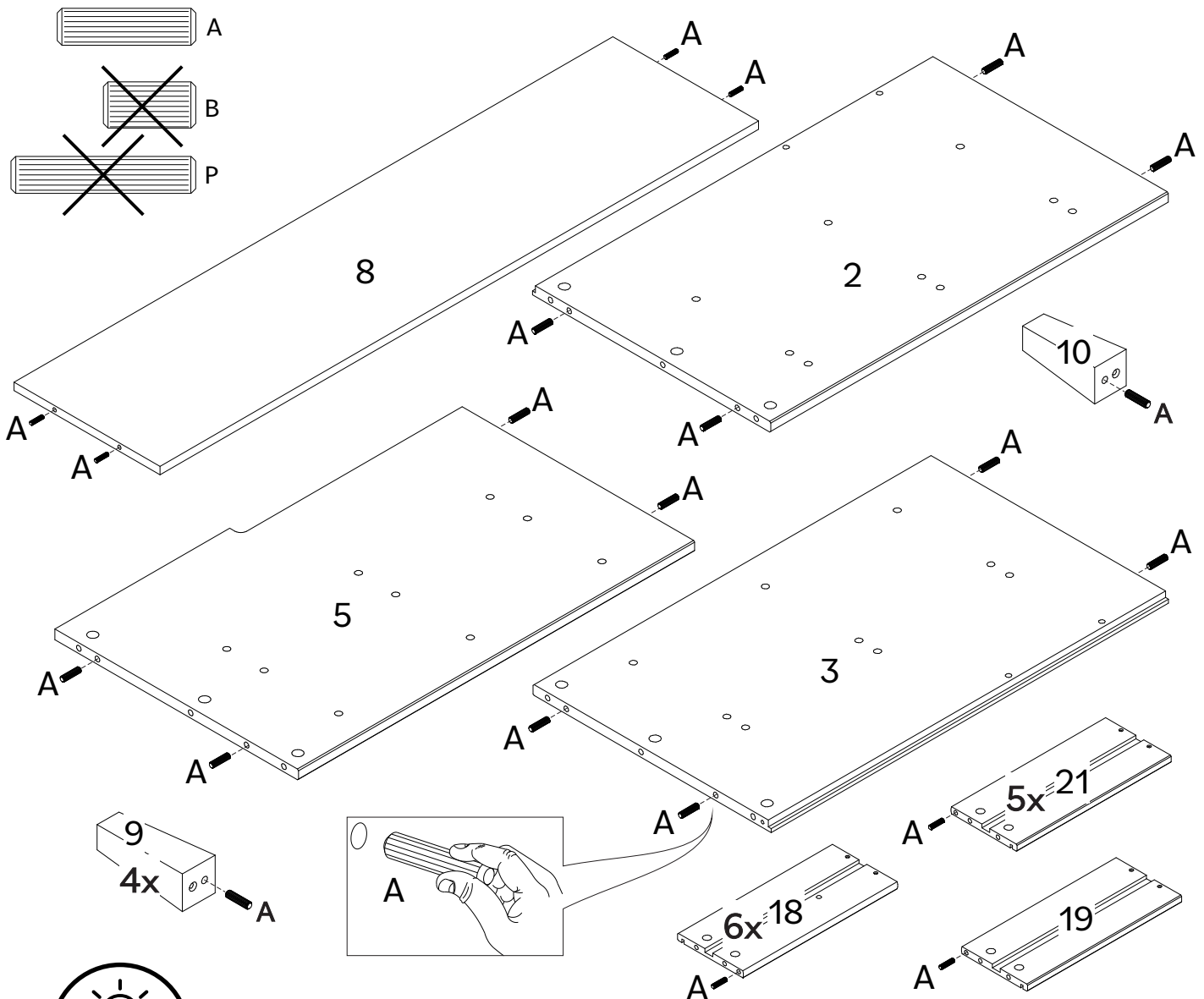

## Tip

Pour que ton produit conserve son meilleur aspect et sans rayures, essaie de le monter sur une surface souple telle qu'un tapis ou une couverture. Cela permet d'éviter les rayures accidentelles et de garder tes meubles en bon état !

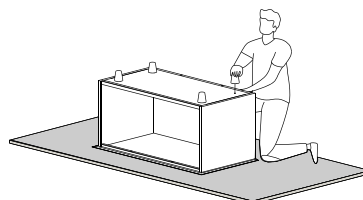

Para mantener su producto con el mejor aspecto y sin arañazos, pruebe a montarlo sobre una superficie blanda, como una alfombra o una manta. Así evitará arañazos accidentales y mantendrá sus muebles en perfecto estado.

# Étape / Paso 3

(FR) Insérez le Goujon (H) dans le Panneau Supérieur (1), Façade du Tiroir (12) et la Façade du Tiroir (13) à l'aide d'un tournevis cruciforme.

(ESP) Inserte el Conector (H) en el Panel Superior(1), Frente del Cajón (12) y el Frente del Cajón (13) usando un destornillador Phillips.

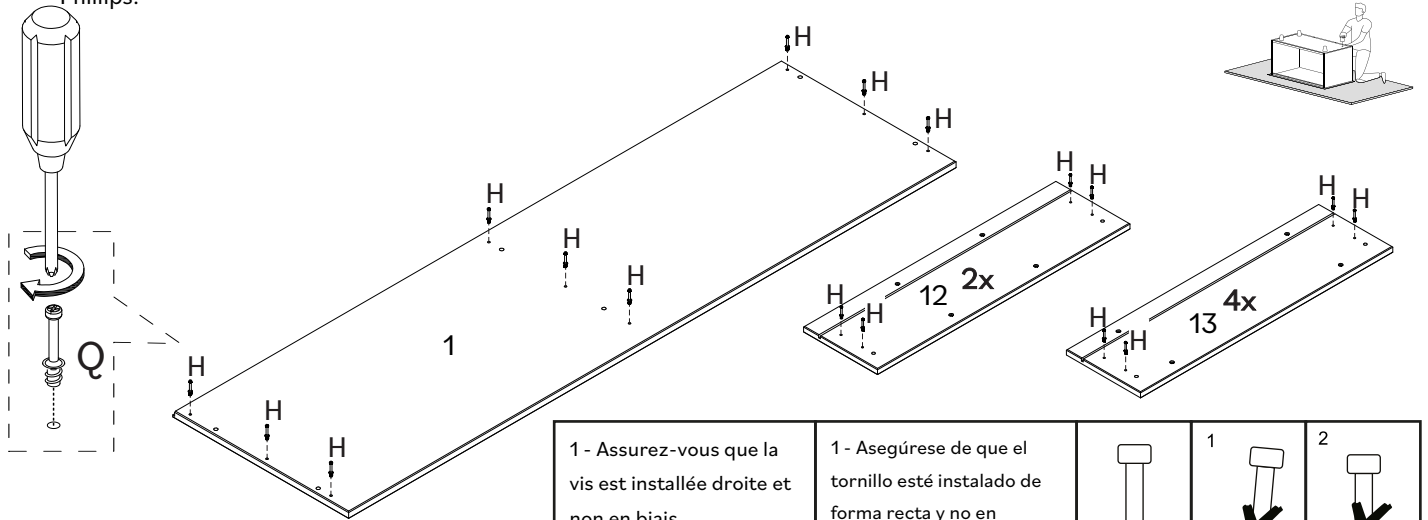

1 - Assurez-vous que la vis est installée droite et non en biais.  
2 - Serrez la vis jusqu'à ce que l'épaulement de la vis soit de niveau. Ne pas trop serrer.

1 - Asegúrese de que el tornillo esté instalado de forma recta y no en ángulo.  
2 - Apriete el tornillo hasta que el hombro del tornillo quede nivelado. No apriete demasiado.

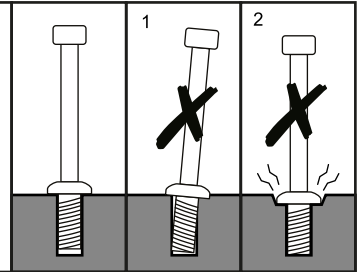

# Étape / Paso 4

(FR) Fixez la Glissière (17) au Panneau Gauche (2) et au Panneau Droit (3) avec la vVs (C) à l'aide d'un tournevis cruciforme.

(ESP) Fije la Corredera (17) al Panel Izquierdo (2) y al Panel Derecho (3) con el Tornillo (C) usando un destornillador Phillips.

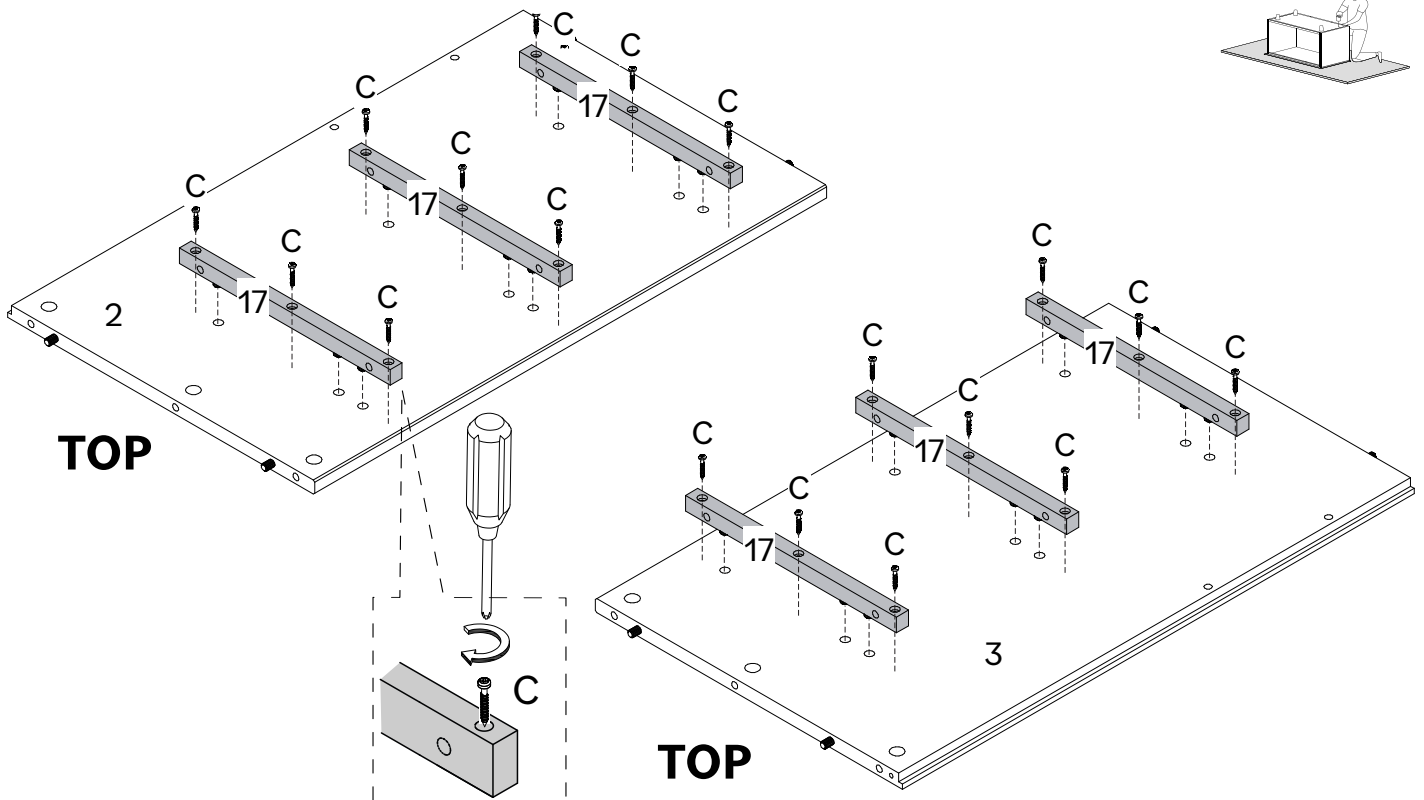

# Étape / Paso 5

(FR)

Fixez la Glissière (6) au Panneau Central (5) avec la Vis (C) à l'aide d'un tournevis cruciforme.

(ESP)

Fije la Corredera (6) al Panel Central (5) con el Tornillo (C) usando un destornillador Phillips.

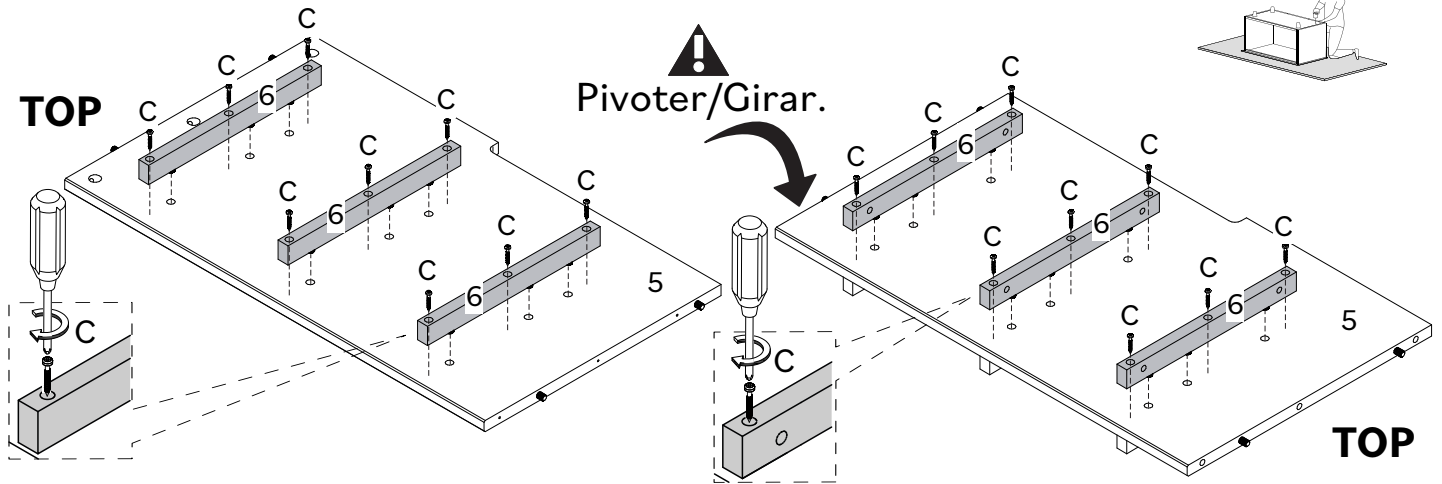

# Étape / Paso 6

(FR) Fixez le Panneau Gauche (2) et le Panneau Central (5) sur le Panneau Supérieur (1). Insérez les Boitiers (I) dans les trous du Panneau Gauche (2) et de le Panneau Central (5) pour les fixer avec un tournevis cruciforme.

(ESP) Coloque el Panel Izquierdo (2) y Panel Central (5) en la Parte Superior (1). Inserte las Trabas del Conector (I) en los agujeros del Panel Izquierdo (2) y en el Panel Central (5) para asegurarlos con un destornillador Phillips.

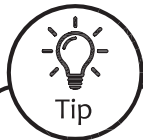
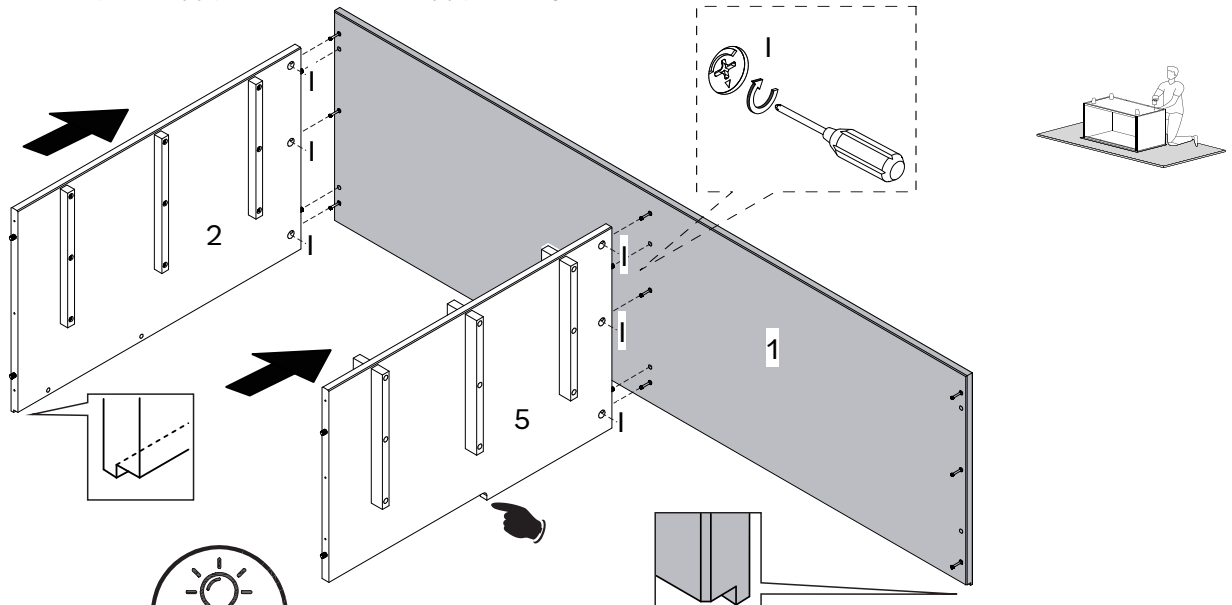

Tip

## Goujon

Goujon permet de joindre deux pièces en toute sécurité. Suis ces étapes simples.

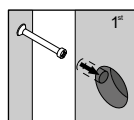

1: Insère le Goujon dans les orifices du côté plat. Ne serre pas trop!  
1: Coloca el Conector en los orificios del lado plano. ¡No aprietes demasiado!

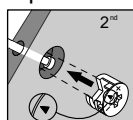

2: Joins les pièces en bois. Les Goujons entrent dans les orifices qui ont des trous sur les côtés, tu dois pouvoir voir les Goujons à travers ceux-ci. Après avoir installé les pièces, insère le Boîtier dans les orifices latéraux.  
2: Una las piezas de madera. Los Conectores entran en las piezas que tienen agujeros en los lados, por lo que deberías poder ver los Conectores a través de ellos. Después de encajar las piezas, inserta la Traba del Conector en los orificios laterales.

## Conector

Los Conectores ayudan a unir de forma segura dos piezas. Sigue estas fáciles etapas.

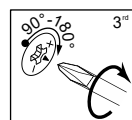

3: Sur la partie arrière du Boîtier, il aura la forme d'un « C ». Insère le Boîtier de manière à ce que l'ouverture « C » s'emboîte à la Conector. Serre-la avec le tournevis.

3: La parte posterior de la Traba tendrá la forma de "C". Inserta la Traba de modo que la abertura de la "C" encaje en el Conector. Apriétalo con un destornillador.

# Étape / Paso 7

(FR)  
Joindre le Panneau Arrière Inférieur (10) au Panneau Gauche (2).  
(ESP)  
Unir el Panel Trasero Inferior (10) al Panel Izquierdo (2).

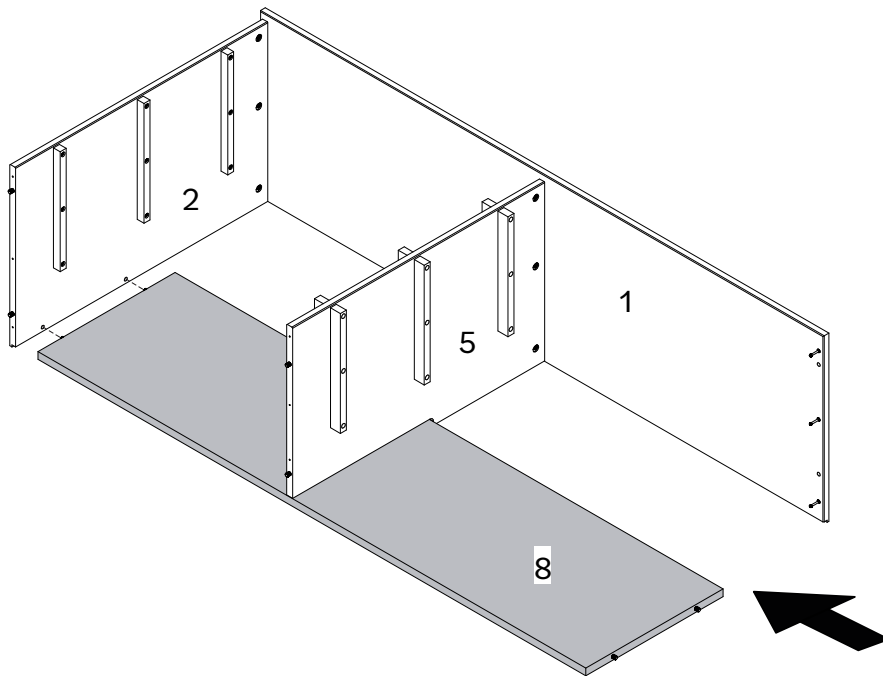

# Étape / Paso 8

(FR)  
Joindre le Panneau Droit (3) au Panneau Supérieur (1) et au Panneau Arrière (8).  
(ESP)  
Unir el Panel Derecho (3) al Panel Superior (1) y al Panel Trasero (8).

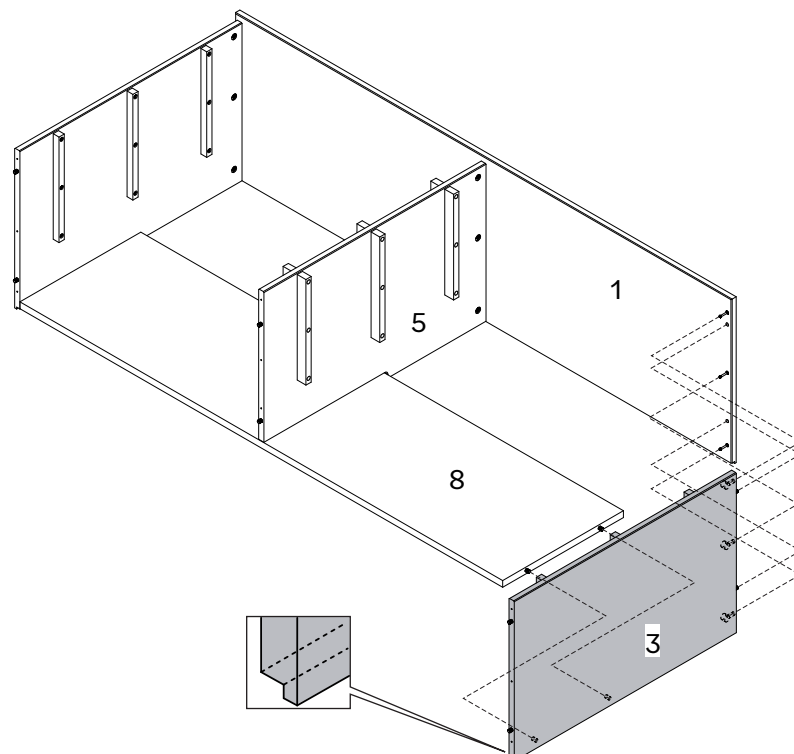

# Étape / Paso 9

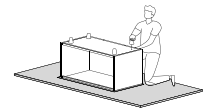

(FR)

Insérez el Boitier (1) dans le trou du Panneau Droit (3), puis fixez-le avec un tournevis cruciforme.

(ESP)

Inserte la Traba del Conector (1) en el agujero del Panel Derecho (3), para asegurarlo con un destornillador Phillips.

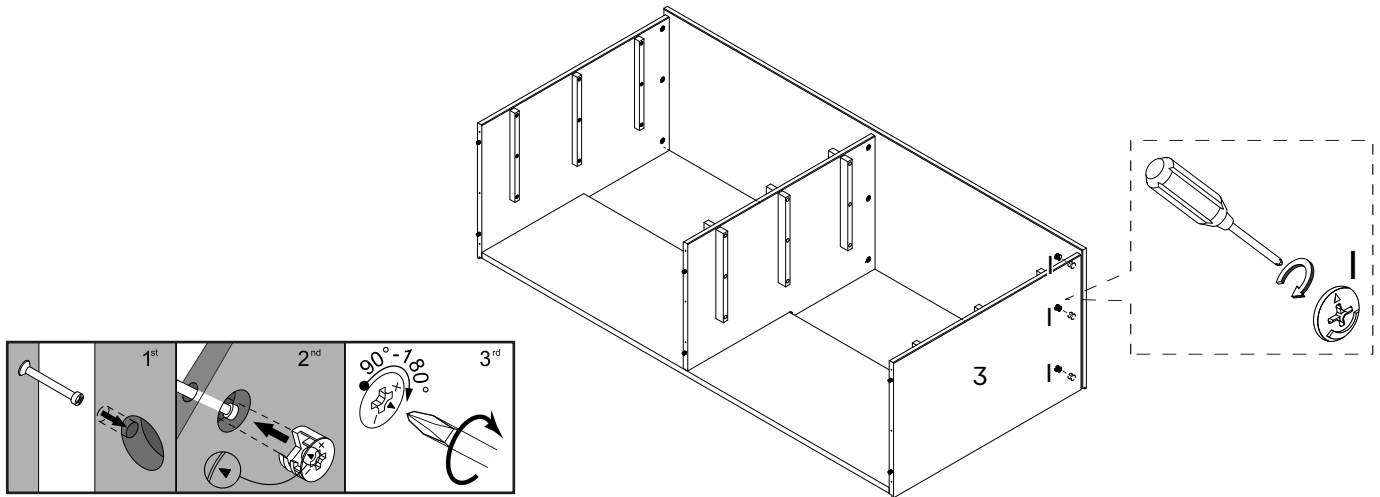

# Étape / Paso 10

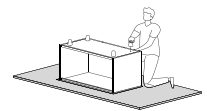

(FR) Insérez Douille du Pied (Q) dans le trou du Pied Central (10) et insérez le Pied de Nivellement (R).

(R)

(ESP) Inserte el Casquillo del Pie (Q) en el orificio del Pie Central (10) e inserte la Zapata Niveladora (R).

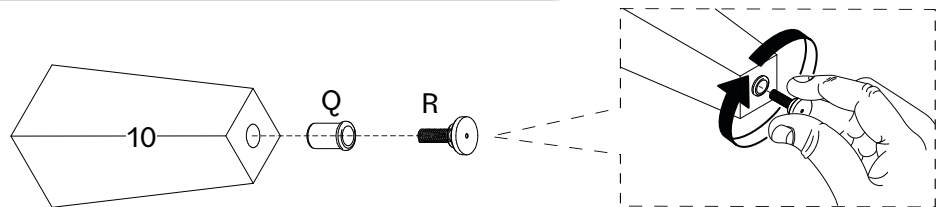

# Étape / Paso 11

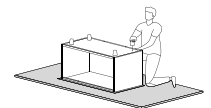

(FR)

Fixez le Pied (9) et le Pied Central (10) au Panneau Inférieur (4) avec le Boulon (G) à l'aide de la clé hexagonale (K)

(ESP)

Fije el Pie (9) y el Pie Central (10) al Panel Inferior (4) con el Perno (G) utilizando la llave hexagonal (K).

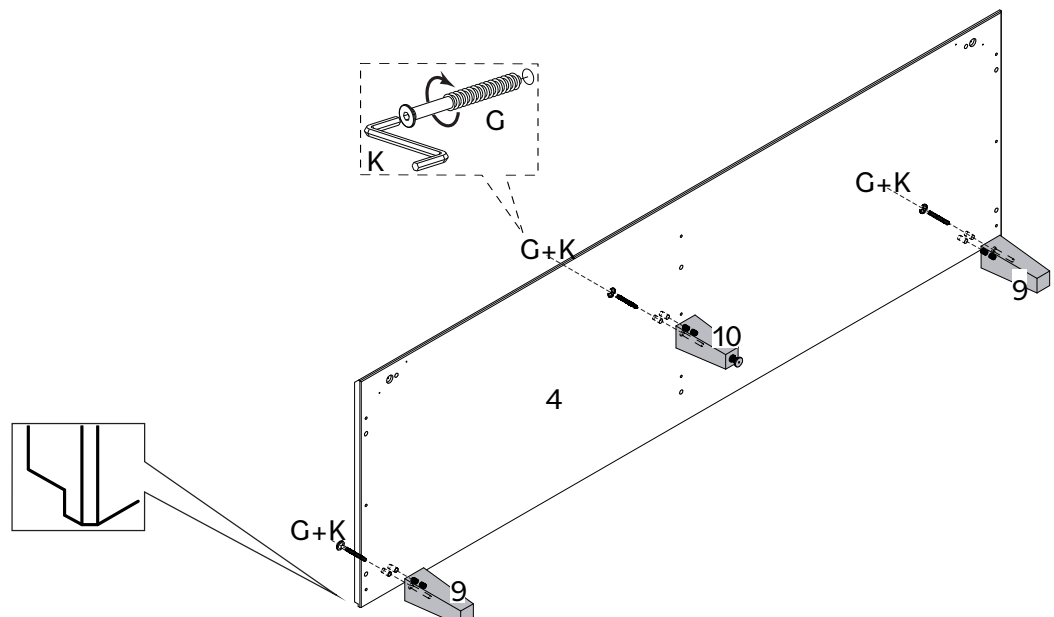

# Étape / Paso 12

(FR)

Fixez la Plaque Métallique (T) au Pied (9) avec le Boulon (S) et la clé hexagonale (K).

(ESP)

Fije la Placa Metálica (T) al Pie (9) con el Perno (S) y la llave hexagonal (K).

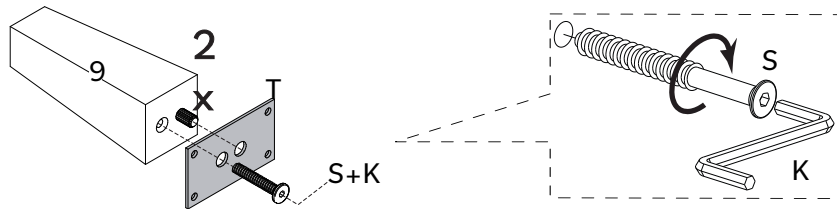
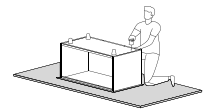

# Étape / Paso 13

(FR)

Fixez le Pied (11) au Panneau Inférieur (4) avec la Vis (N) à l'aide d'un tournevis cruciforme.

(ESP)

Fije el Pie (11) al Panel Inferior (4) con el Tornillo (N) usando un destornillador Phillips.

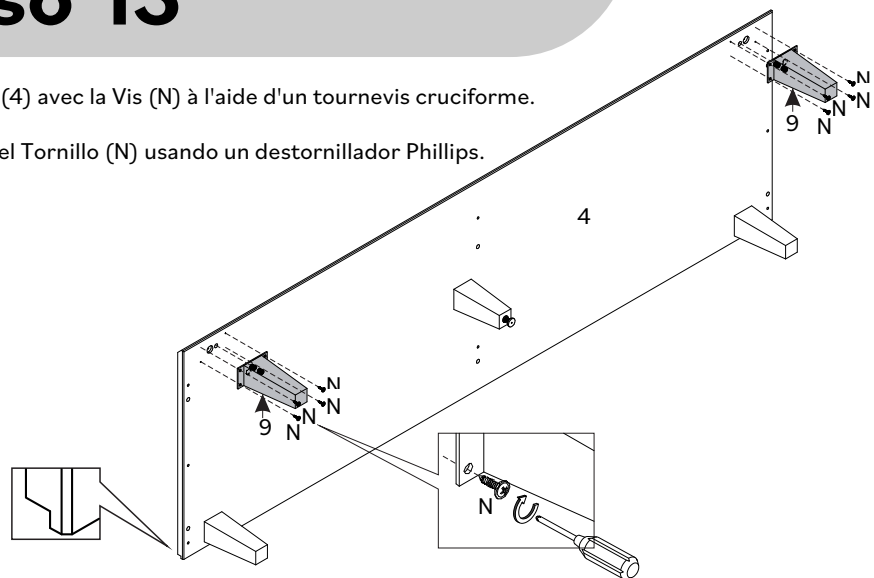
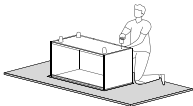

# Étape / Paso 14

(FR)

Fixez le Panneau Inférieur (4) au Panneau Gauche (2), au Panneau Central (5) et au Panneau Droit (3) avec la Vis (E) à l'aide d'un tournevis cruciforme.

(ESP)

Fije el Panel Inferior (4) al Panel Izquierdo (2), al Panel Central (5) y al Panel Derecho (3) con el Tornillo (E) usando un destornillador Phillips.

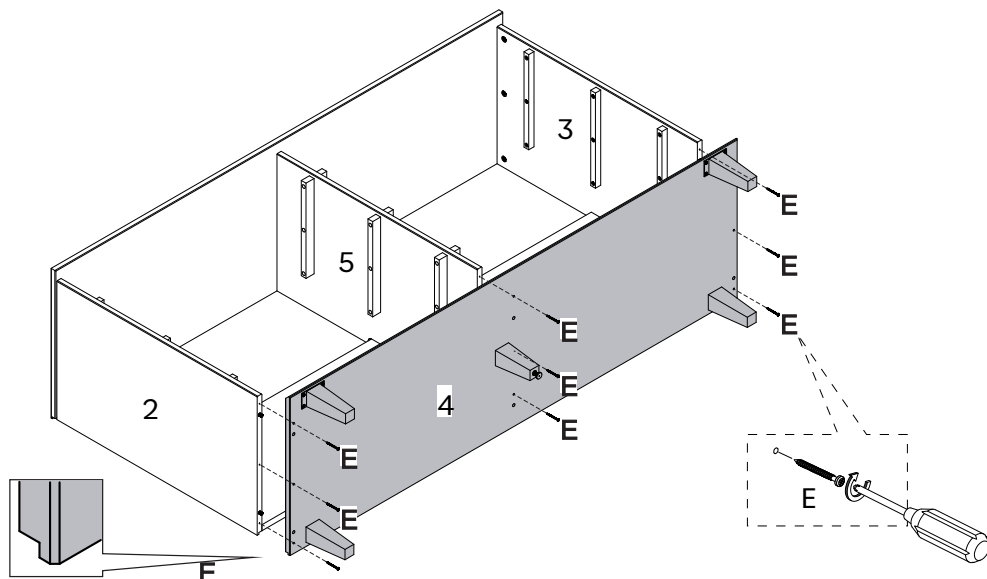
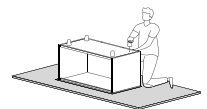

# Étape / Paso 15

(FR)

Fixez le Panneau Arrière (7) à l'Arrière de la commode avec des Clous (F), Plaque (J) à l'aide d'un marteau.

(ESP)

Asegure el Panel Trasero (7) a la parte posterior de la cómoda con Clavos (F) y la Placa (J) usando un martillo.

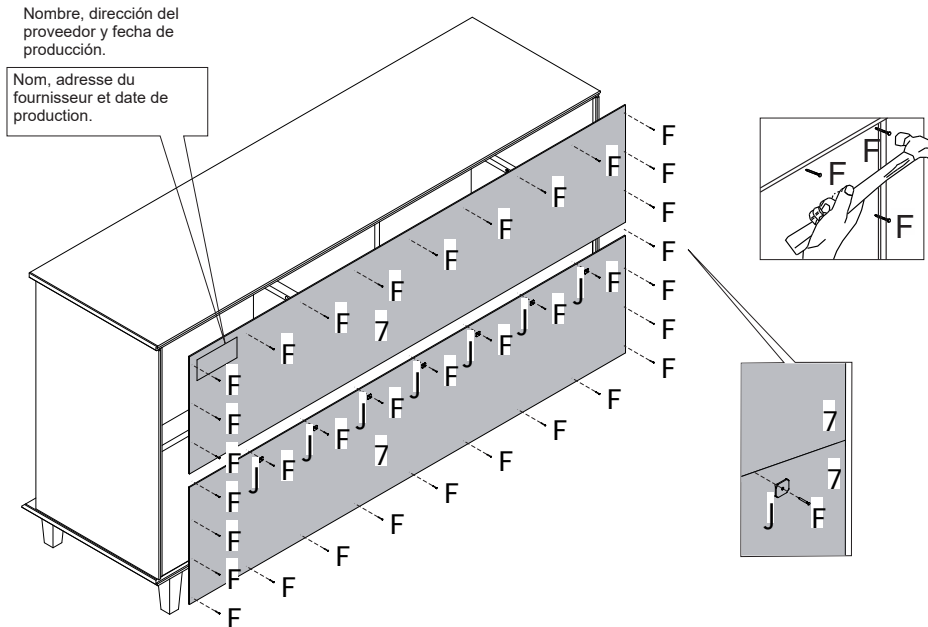

# Étape / Paso 16

(FR)

Insérez la Cheville (A) dans le trou avant des Glissières en bois (17) et des Glissières larges (6).

(ESP)

Inserte la Espiga (A) en el orificio frontal de las Correderas (17) y de las Correderas Grandes (6).

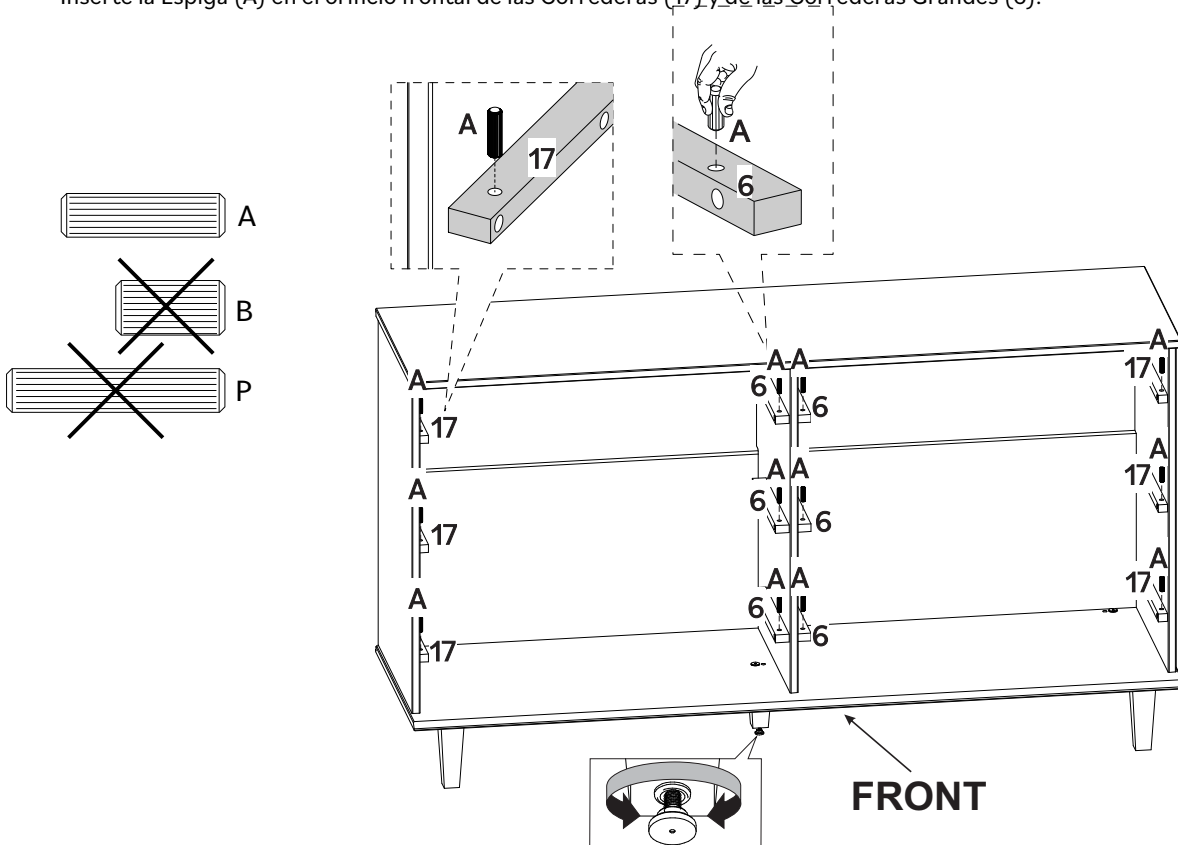



# Étape / Paso 17

(FR)

Fixez la Façade du tiroir (12) aux Poignées (11) avec des Vis (C) et un tournevis cruciforme. Fixez la Façade du tiroir (13) aux Poignées (11) avec des Vis (C) et un tournevis cruciforme.

(ESP)

Fije el Frente del Cajón (12) a las Manijas (11) con tornillos (C) y un destornillador Phillips. Fije el Frente del Cajón (13) a las Manijas (11) con tornillos (C) y un destornillador Phillips.

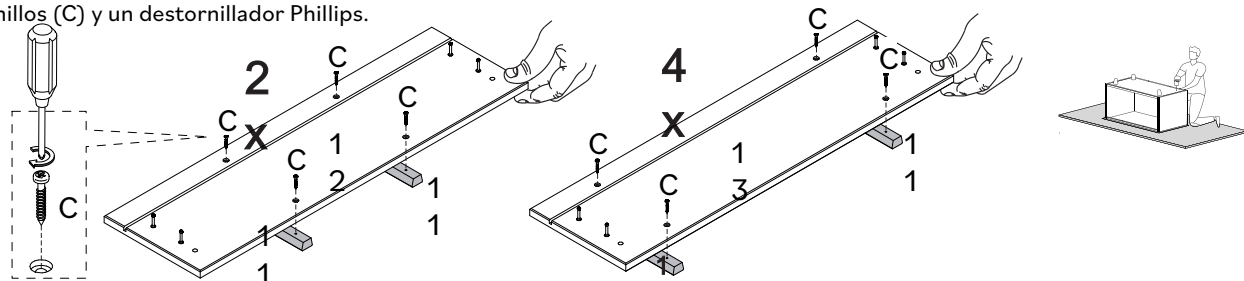

# Étape / Paso 18

(FR)

Fixez le Côté Droit du tiroir (19), Côté Droit du tiroir (21), Côté Gauche du tiroir (18) à la Façade du tiroir (12) et (13) avec le Boîtier (R) à l'aide d'un tournevis cruciforme.

(ESP)

Asegure el Lado Derecho del Cajón (19), Lado Derecho del Cajón (21), el Lado Izquierdo del Cajón (18) al Frente del Cajón (12) y (13) con la Traba del Conector (R) usando un destornillador Phillips.

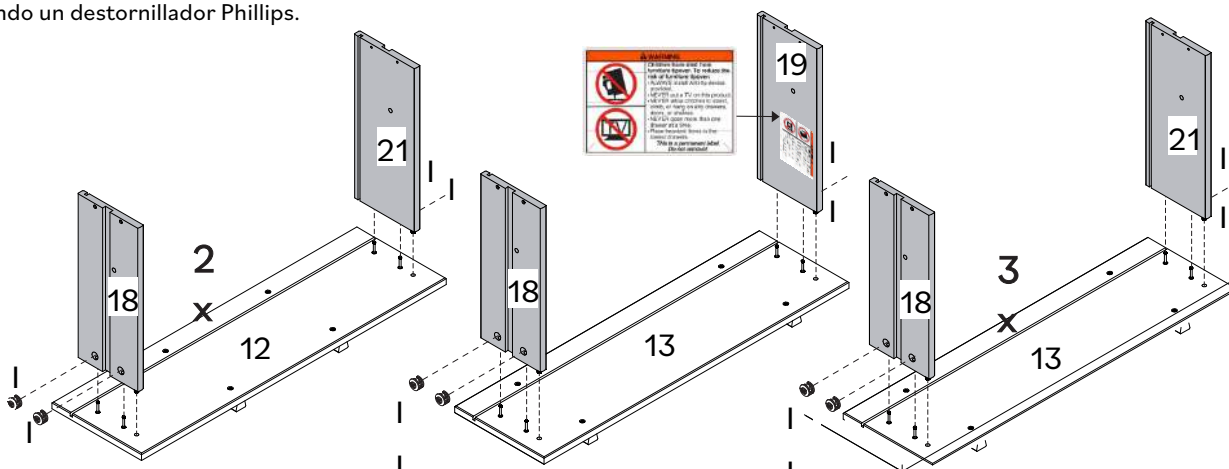
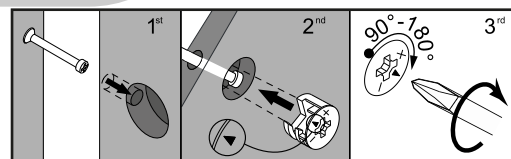

# Étape / Paso 19

(FR)

Insérez le Fond du tiroir (13) dans les rainures du Côté Gauche du tiroir (18), Côté Droit du tiroir (19) et du Côté Droit du tiroir (21) et fixez l'Arrière du tiroir (14) avec la Vis (D) à l'aide d'un tournevis cruciforme.

(ESP)

Inserte la parte Inferior del Cajón (13) en las ranuras del Lado Izquierdo del Cajón (18), Lado Derecho del Cajón (19) y el Lado Derecho del Cajón (21) y asegure la parte Trasera del Cajón (14) con el tornillo (D) usando un destornillador Phillips.

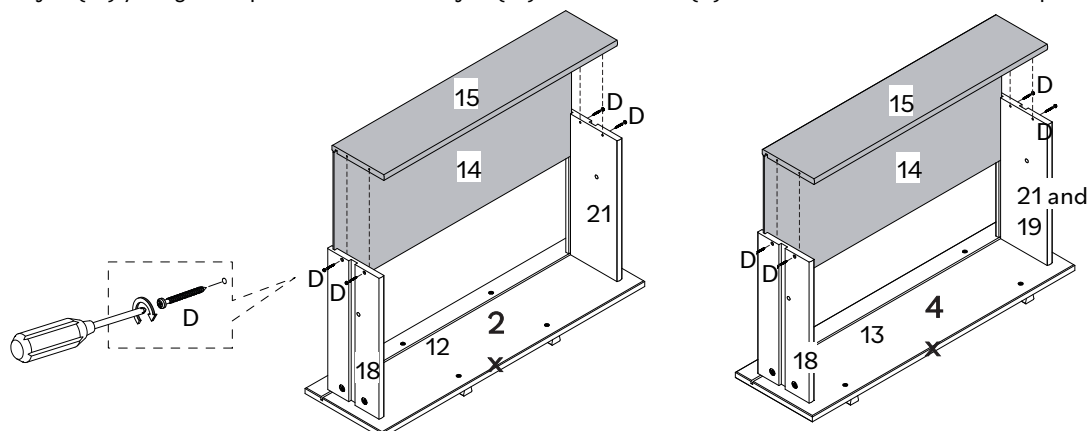

# Étape / Paso 20

(FR)

Insérez la cheville en bois (P) à l'intérieur de chaque tiroir, avec le tiroir à l'intérieur du meuble, après avoir passé la cheville en bois qui se trouve dans la glissière du tiroir. La goupille n'est pas au ras du panneau, elle est légèrement à l'intérieur du tiroir pour vous aider lorsque vous devez retirer la goupille de verrouillage, pour retirer le tiroir.

(ESP)

Insertar la Espiga (P) en el interior de cada cajón, con el cajón dentro del mueble, después de pasar el pasador de madera que se encuentra en la corredera del cajón. El pasador no está al ras del panel, está ligeramente dentro del cajón para ayudar cuando necesita quitar el pasador de bloqueo para quitar el cajón..

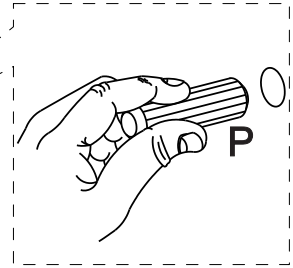
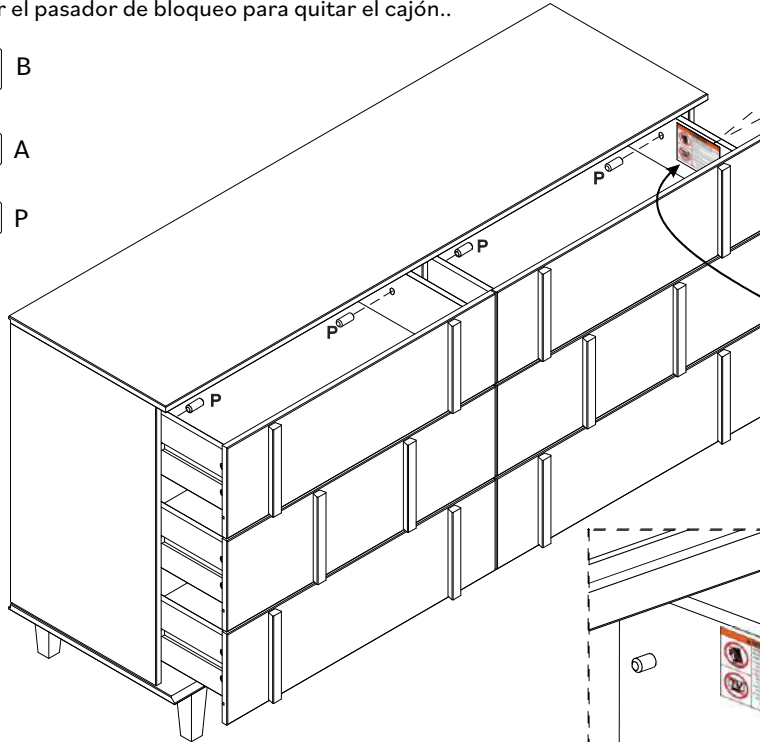
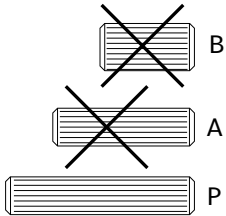

Le côté du tiroir portant l'inscription AVERTISSEMENT doit être installé dans l'espace supérieur droit. El lado del cajón etiquetado ADVERTENCIA debe colocarse en el espacio superior derecho.

# Étape / Paso 21

(FR)

Enfin, fixons votre commode au mur ! Fixez l'ruban (L) à votre commode à l'aide d'une rondelle (M) et d'une vis (N).

(ESP)

¡Por último, fijemos tu tocador a la pared! Fije el cinta (L) a su tocador usando una arandela (M) y un tornillo (N).

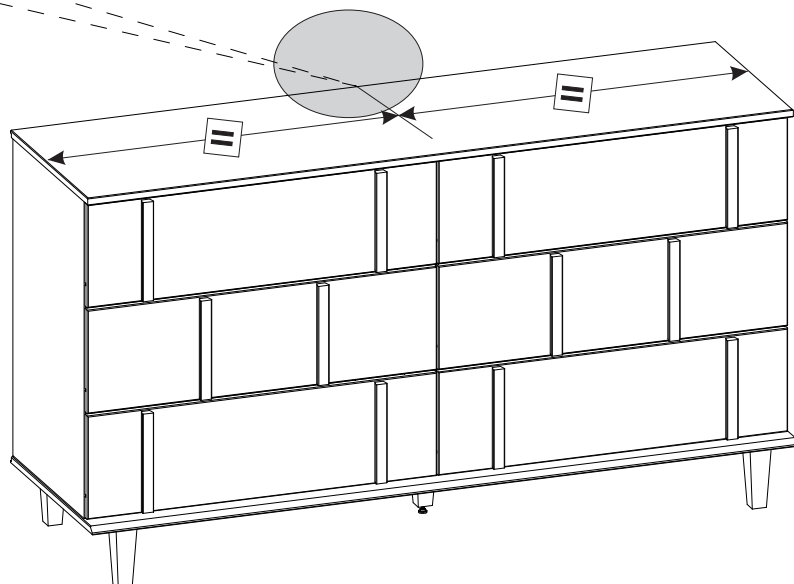
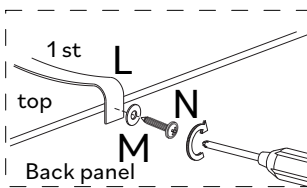

# Étape / Paso 22

(FR)

Insère la douille en plastique (O) dans le mur. Ensuite fixe le ruban (L) au mur à l'aide de la rondelle (M) et des vis (E).

(ESP)

Coloca el casquillo de plástico (O) en la pared. Luego, fija la cinta (L) a la pared usando la arandela (M) y el tornillo (E).

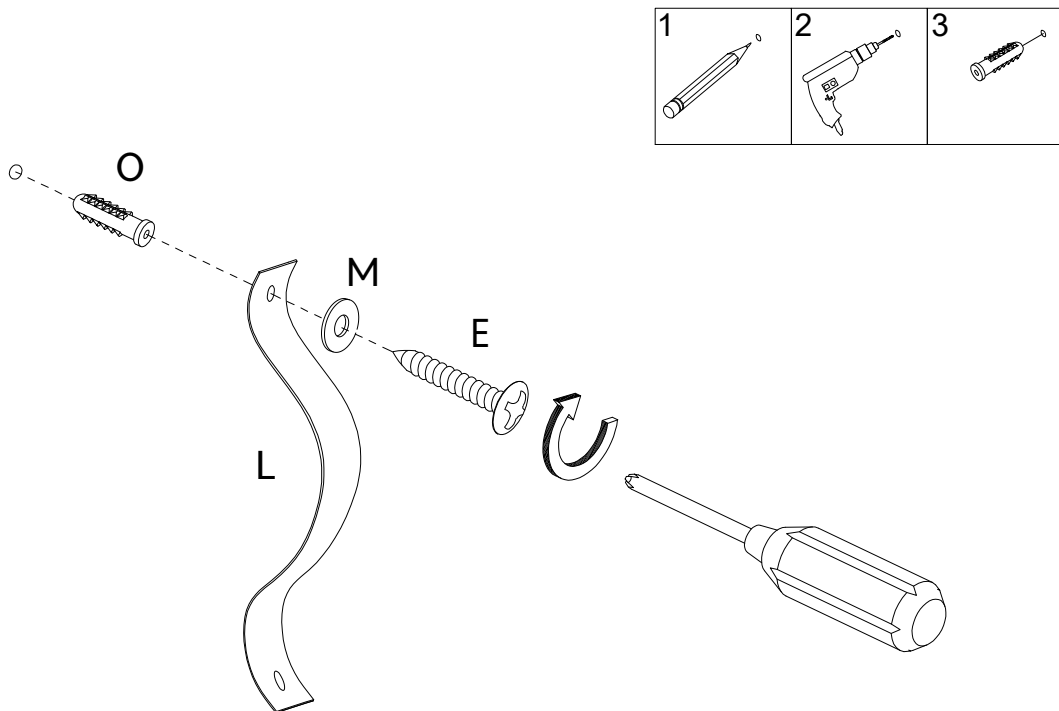

## Avertissement

Des blessures graves, voire mortelles, peuvent survenir en cas de renversement de meubles. Pour éviter que le meuble ne bascule, nous recommandons de le xer définitivement au mur. L'ancrage mural et les autres composants sont inclus dans ce produit. Assure-toi que les composants sont adaptés à tes murs avant l'installation, car différents matériaux de mur peuvent nécessiter différents types d'ancrages.

Le nom et l'adresse du fabricant responsable des composants anti-basculer ainsi que la date de production se trouvent sur l'étiquette au dos du meuble.

## Advertencia

Pueden ocurrir lesiones graves o fatales debido a la caída de muebles. Para evitar que los muebles se caigan, recomendamos que se jenen permanentemente a la pared. El anclaje de pared y los herrajes están incluidos en este producto. Asegúrate de que los herrajes sean adecuados para tus paredes antes de la instalación, ya que diferentes materiales de pared pueden requerir diferentes tipos de anclajes.

El nombre y la dirección del fabricante responsable de los herrajes antivuelco y la fecha de producción se pueden encontrar en la etiqueta de la parte trasera de los muebles.

Tu as réussi ! Profite de ton nouveau  
commode!

¡Lo ha conseguido!  
¡Disfrute de su nueva cómoda!

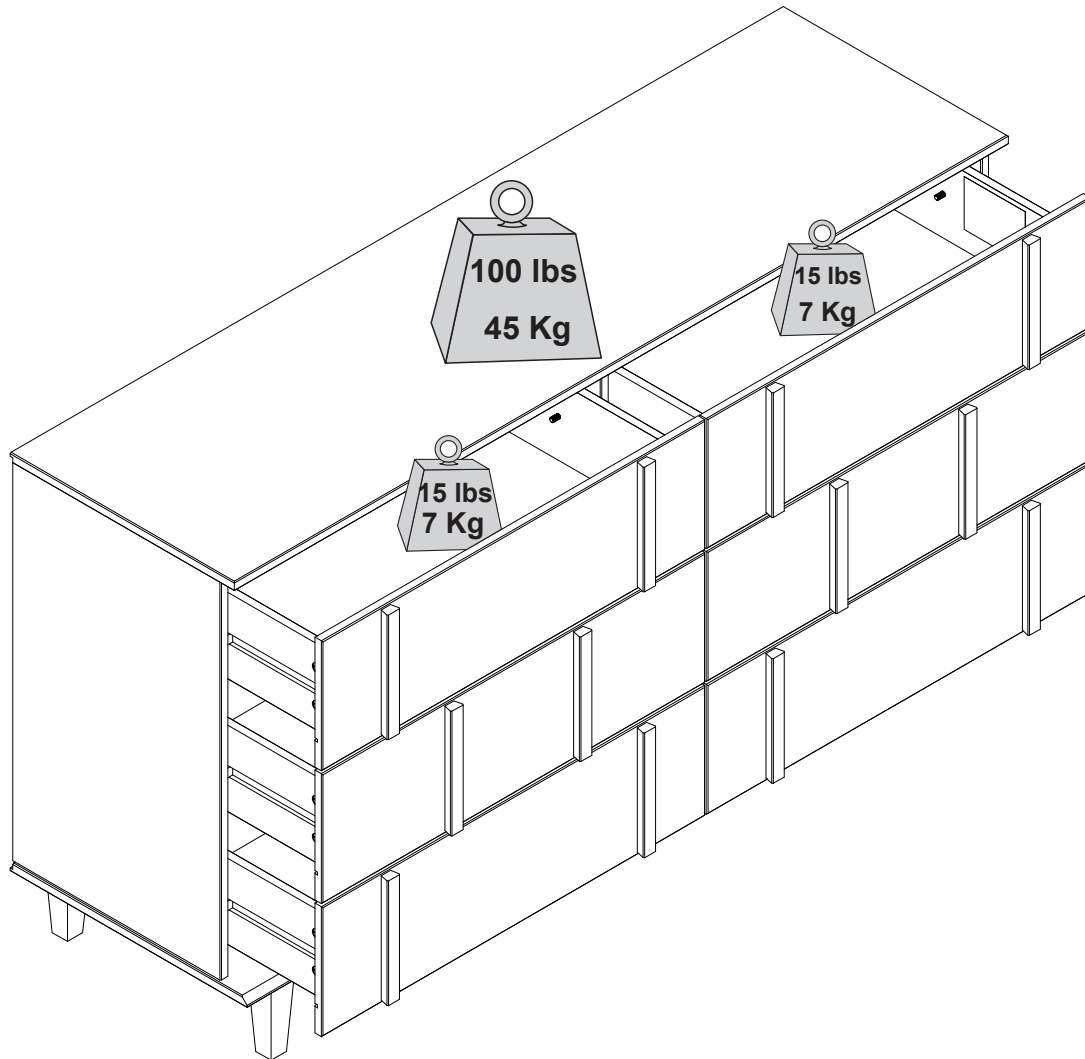

**Nous aimerions t'en entendre parler et le voir.**

S'il te plait, laisse-nous un commentaire ou publie une photo sur  
**#mywalkerredisonhome**

**¡Enhorabuena por sus nuevos muebles!**

Nos encantaría oírlo y verlo.

Por favor, déjenos un comentario o publique una foto con  
**#mywalkerredisonhome**

## Assembler des meubles peut parfois être compliqué.

Notre équipe de service client, située dans l'Utah, est là pour obtenir des informations sur les produits, aider pour l'assemblage d'un produit ou pour tout autre problème de support client.

Appelle-nous **801-433-3008**

Envoie-nous les e-mails à [service@walkeredison.com](mailto:service@walkeredison.com)

Visite notre site accueil au client à

[walkeredison.com/pages/customer-service](http://walkeredison.com/pages/customer-service)

Nous sommes disponibles pour t'aider du Lundi au Jeudi de 8 am - 5 pm, Vendredi de 8 am - 3 pm MST.

Pour plus de détails sur les vidéos d'assemblage, les instructions d'assemblage, les pièces de rechange et le service client.

NUMÉRISER ICI.



Pour le nettoyage, n'utilise jamais d'abrasifs, utilise un chiffon doux et de l'eau avec du savon neutre pour nettoyer les meubles.

## A veces, montar muebles puede resultar complicado.

Nuestro equipo de atención al cliente, ubicado en Utah, está a su disposición para informarle sobre los productos, ayudarle a montarlos o resolver cualquier otro problema de atención al cliente.

Llámenos **801-433-3008**

Envíenos un correo electrónico a [service@walkeredison.com](mailto:service@walkeredison.com)

Visite nuestra página web de atención al cliente

[walkeredison.com/pages/customer-service](http://walkeredison.com/pages/customer-service)

Estamos a su disposición para ayudarle de lunes a jueves de 8:00 a 17:00, viernes de 8:00 a 15:00 MST.

Para más detalles sobre videos de montaje, instrucciones de montaje, piezas de recambio y servicio de atención al cliente

ESCANEE AQUÍ.



Para la limpieza, nunca utilice productos abrasivos, utilice un paño suave y agua con jabón neutro para limpiar los muebles.