

# ADCRAFT®



## **INSTRUCTION MANUAL**

FW-1500W/C

### **FULL SIZE COOKER/WARMER**

This manual contains important information regarding your Adcraft unit. Please read this manual thoroughly prior to equipment set-up, operation and maintenance. Failure to comply with regular maintenance guidelines outlined in this manual may void the warranty.



## WARNINGS

- Do not touch any hot surfaces
- Do not immerse unit, cord or plug in liquid at any time
- Unplug cord from outlet when not in use and before cleaning
- Plug only into a 3-hole grounded electrical outlet of appropriate voltage
- Do not operate unattended
- Do not use this unit for anything other than intended use
- Do not use outdoors
- Always use on a firm, dry and level surface at least 12" from walls or any other obstruction
- Do not use if unit has a damaged cord or plug, in the event the appliance malfunctions, or has been damaged in any manner
- Keep children and animals away from unit
- Any incorrect installation, alterations, adjustments and/or improper maintenance can lead to property loss and injury. All repairs should be done by authorized professionals only.
- Ensure that the designated power supply is adequate for continual usage and the voltage is correct
- NEVER operate this unit without water

**IMPORTANT NOTICE** – TURN SWITCH TO THE MAXIMUM HEAT SETTING FOR 30 MINUTES TO PREHEAT. AFTER 30 MINUTES TURN THE DIAL BACK TO KEEP FOOD WARM.

## TO USE

1. Make sure the power supply you are using is adequate.
2. Fill the well with 4 quarts of water. (Do not fill with more than 4 quarts. If the water level is too high, water may overflow when the food pan is inserted. Overflow will enter the electrical compartment and cause a short circuit or electrical shock).
3. Plug the cord into a three hole grounded electrical outlet of appropriate voltage.
4. Preheat the water in the well by covering the well with an empty food container or cover. Set the heat control to the maximum heat setting. Preheat for 30 minutes.
5. Place stainless steel food pan containing food into the food warmer.
6. Reduce the setting of the knob by  $\frac{1}{4}$  and monitor food temperatures closely for food safety. The United States Public Health Service recommends that food be held at a minimum of 140° F (and/or in compliance with local health codes) to prevent bacteria growth. Maintain water level at 4 quarts. Periodically, (approximately every 2 hours) remove food pan and check the water level. Add hot water if needed and adjust up or down as required by the food type.

HOT WATER AND STEAM IN THE WELL CAN SEVERELY BURN SKIN. USE PROTECTIVE GLOVES, MITTS OR POTHOLDERS WHEN REMOVING FOOD CONTAINERS OR COVERS. HOT FOOD CAN ALSO CAUSE BURNS. HANDLE FOOD CAREFULLY.

**CLEANING - NOTE:** To maintain cleanliness and increase service life, the food warmer should be cleaned daily. Do not immerse the food warmer in water or any other liquid, if liquid enters the electrical compartment it may cause a short circuit or electrical shock.

1. Before cleaning or attempting to move food warmer, unplug and let the unit cool completely.
2. Carefully empty the water from the well.
3. Wipe the entire unit with a clean soft cloth until it is completely dry.
4. To avoid damage to the well, do not use abrasive cleaners or scouring pads.
5. If soap or chemical cleaners are used, be sure they are completely rinsed away with clean water immediately after cleaning. Chemical residue could damage or corrode the surfaces of the unit.

There are no serviceable parts within this appliance. To avoid serious injury or damage, never attempt to repair the food warmer or replace a damaged cord yourself. Contact a professional repair service.

## Wiring Diagram for the Full Size Cooker/Warmer

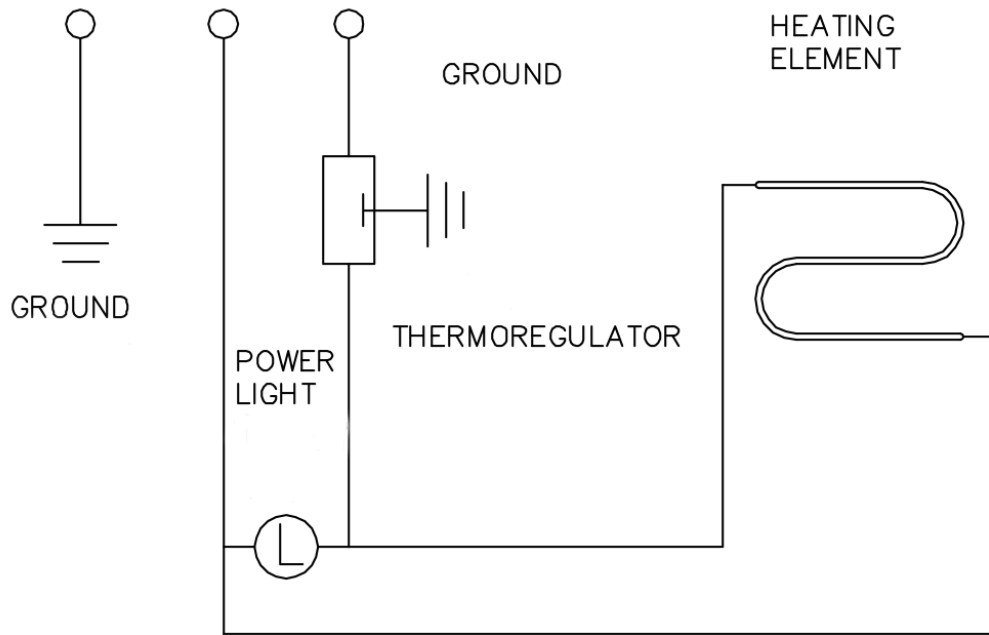

## Parts Diagram and Replacement Parts for the Full Size Cooker/Warmer

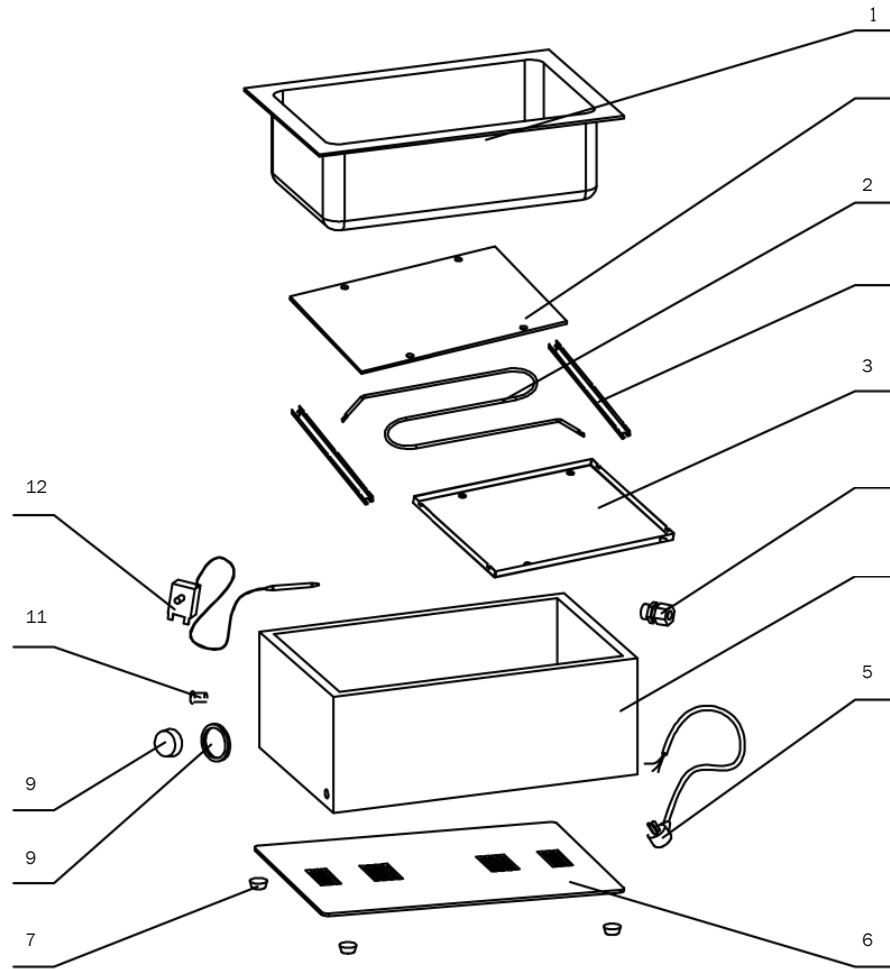

Reference Number	Description
1	Water Pan
2	Heating Element
3	Reflector Pan
5	Power Cord and Strain Relief
6	Bottom Cover
7	Rubber Foot
8	Shell
9	Temperature Knob
11	Indicator Light - Red
12	Thermostat
13	Stand
14	Limiting Thermostat Stand
15	Limiting Thermostat



## 1-YEAR LIMITED WARRANTY

Admiral Craft Equipment Corp. (the "Company") warrants this product (the "Product") will be free from failures in material and workmanship for one (1) year from the date of original purchase with proof of purchase, provided that the Product is operated and maintained in conformity with the Owner's Manual. This Limited Warranty is non-transferable. During this period, your exclusive remedy is repair or replacement without charge of the Product or any component found to be defective at the Company's discretion. If the Product or any component is no longer available, the Company will replace it with a similar one of equal or greater value. This Limited Warranty is void if the Product is used with voltage other than 120 Volts. **THIS WARRANTY IS IN LIEU OF ALL IMPLIED WARRANTIES, INCLUDING WARRANTIES OF MERCHANTABILITY, FITNESS FOR A PARTICULAR PURPOSE, PERFORMANCE, OR OTHERWISE, WHICH ARE HEREBY EXCLUDED. IN NO EVENT SHALL THE COMPANY BE LIABLE FOR ANY DAMAGES, WHETHER DIRECT, INDIRECT, INCIDENTAL, FORSEEABLE, CONSEQUENTIAL, OR SPECIAL ARISING OUT OF OR IN CONNECTION WITH THIS PRODUCT INCLUDING DAMAGES ARISING FOR FOOD OR BEVERAGE SPOILAGE CLAIMS.**

You may have other legal rights depending upon where you live. Some States or Provinces do not allow limitations on warranties so the foregoing may not apply to you.

### WARRANTY EXCLUSIONS

---

#### IMPROPER ELECTRICAL CONNECTIONS:

The Company is not responsible for the repair or replacement of failed or damaged components resulting from electrical power failure, the use of extension cords, low voltage, or voltage spikes to the Product.

#### IMPROPER USAGE:

This Limited Warranty does not cover failure or other damages to the Product resulting from (i) improper usage or installation or failure to clean and/or maintain the Product as set forth in the Owner's Manual; or (ii) accident, misuse, abuse, negligence, or modification or alteration of the Product.

#### CONSUMABLES:

This Limited Warranty does not include consumables or wear-and-tear items such as legs, feet, plastic component parts, splash shields, filters, gaskets, and non-stick cooking surfaces.

#### ADJUSTMENTS & CALIBRATIONS:

Leveling, tightening of fasteners, or utility connections normally associated with the original installation are the responsibility of the dealer, installer, or the end user and not the responsibility of the Company and will not be considered warranty issues.

If you think the Product has failed, or requires service, within its warranty period, please contact the Company's Customer Care Department through our website at: [www.admiralcraft.com](http://www.admiralcraft.com) "Service" --> "Technical Support Request". A receipt proving the original purchase date will be required for all warranty claims, handwritten receipts are not accepted. You may also be required to return the Product for inspection and evaluation. Return shipping costs are not refundable. The Company is not responsible for returns lost in transit.

This Limited Warranty is Valid only in the USA and Canada.