



**T-BAR ROW**  
Instruction Manual





## **Disclaimer, Terms and Conditions**

### **IMPORTANT**

Please read this entire manual before using the ProsourceFit T-Bar Row. Failure to follow these instructions can lead to significant injury and/or property damage.

ProsourceFit recommends that you always obtain a complete physical examination before beginning any exercise program. If you experience any discomfort while using ProsourceFit T-Bar Row discontinue use & consult your physician.

Please use caution & carefully follow all exercise instructions and use proper technique when using our T-Bar Row. Always modify exercises as needed for your fitness level.

### **Use & Safety Instructions**

- 1. DO NOT** allow children under the age of 18 to use this product without adult or professional supervision.
- 2. DO** inspect every package purchased for missing, factory defective or damaged parts. In the case of missing, damaged or defective parts; do not use the product and contact ProsourceFit customer service for replacement parts free of charge.
- 3. DO** test thoroughly to make sure your T-Bar Row is completely and securely assembled, properly and securely mounted.
- 4.** It is the sole responsibility of the user to determine the location to accommodate the proper use of the T-Bar Row.
- 5. DO** maintain a controlled motion when performing any exercises on the ProsourceFit T-Bar Row.

### **Care & Storage Instructions**

- 1.** Wipe clean with damp cloth and dry immediately.
- 2.** Never expose the T-Bar Row to chemicals.
- 3.** Store in dry and secure place.

## T-BAR ROW INVENTORY



T-BAR ROW WITH 2 TIGHTENING KNOBS

## T-BAR ROW MEASUREMENTS

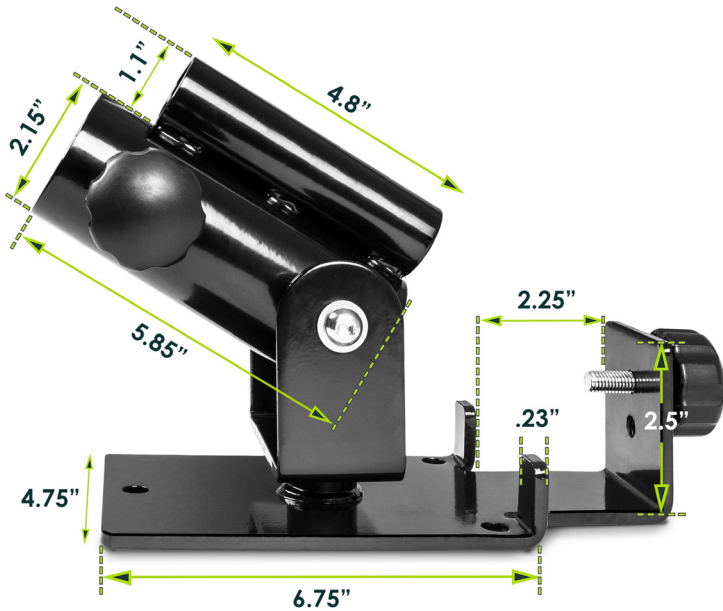

## T-BAR ROW MOUNTING OPTION #1



### STEP 1

Lift a weight bench foot and slide in T-Bar Row base underneath the foot as shown in the diagram above.

### STEP 2

Please tighten the lower knob to fix the T-Bar Row base to the foot of the weight bench. Please make sure that the weight bench is heavy and solid enough to keep the T-Bar Row in place while exercising.

### STEP 3

Insert a barbell sleeve into a T-Bar Row tube. Tighten the top knob by rotating clockwise.

## T-BAR ROW MOUNTING OPTION #2

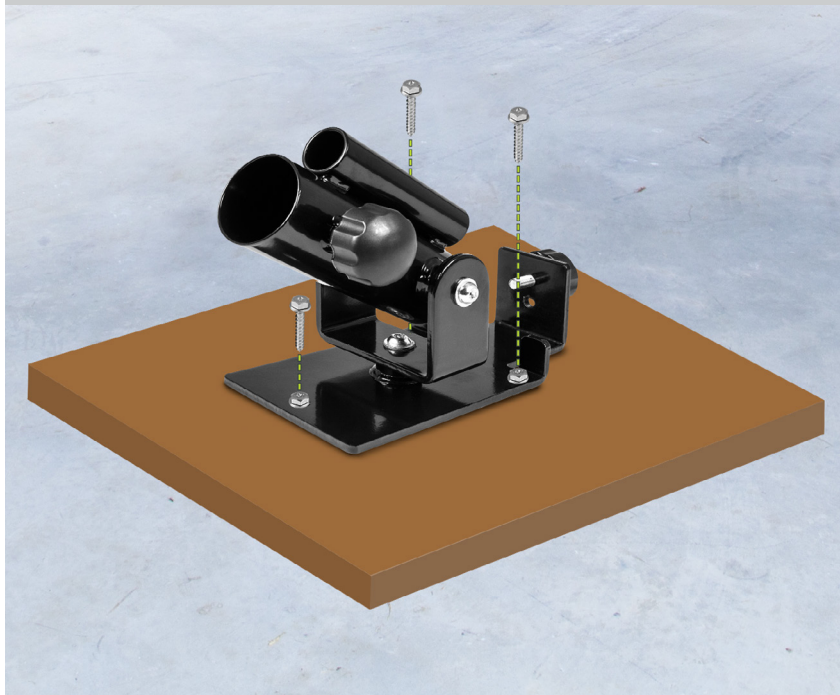

**CAUTION:** The T-Bar Row does not include mounting screws. Use your own judgment when choosing the right screws for the right surface. If you are unable to perform installation, please consult a professional to install.

### STEP 1

The type of screws will depend on the floor surface where the T-Bar Row will be installed. Pre-drill the holes on the floor surface.

### STEP 2

Align T-Bar Row base holes with the predrilled holes on the floor surface. Install the screws accordingly.

### STEP 3

Insert a barbell sleeve into a T-Bar Row tube. Tighten the top knob by rotating clockwise.

## **WARNING:**

Do not use this product in ways not intended by its manufacturers. Failure to do so may result in severe injury or death. Consult your physician before engaging in any regular exercise. Do not use ProsourceFit products for anything other than their intended use. ProsourceFit is not responsible for any problems that arise from the misuse of this product.

## **LIMITED LIFETIME WARRANTY**

Covers manufacturing defects including any defects in materials and workmanship. ProsourceFit has sole discretion to determine manufacturing defects. This Lifetime Warranty does not cover: normal wear and tear, misuse, failing to follow use, care, and safety instructions, loss and/or theft. This Lifetime Warranty applies to all types of defects or failure during standard use.

## **QUESTIONS, CONCERNS OR COMMENTS**

Contact Customer Support by email: [support@prosourcefit.com](mailto:support@prosourcefit.com) or by phone at **1 (855) 552-2637** and we will be happy to help you.



[www.prosourcefit.com](http://www.prosourcefit.com)

## **All information in the manual is property of ProsourceFit**

All trademarks, service marks, word marks, and trade names (collectively "Marks") of ProsourceFit used in this manual (including but not limited to the "ProsourceFit" name and stylized "ProsourceFit" logos) are trademarks or registered trademarks of ProsourceFit. By using these products you accede to all terms and conditions specified herein. All rights reserved.

