

WALKER EDISON

TM

Rebecca 6 Drawer Solid Wood Modern Dresser

SKU# BR6DREBDR-T

LOT: AAYYWW-XXX

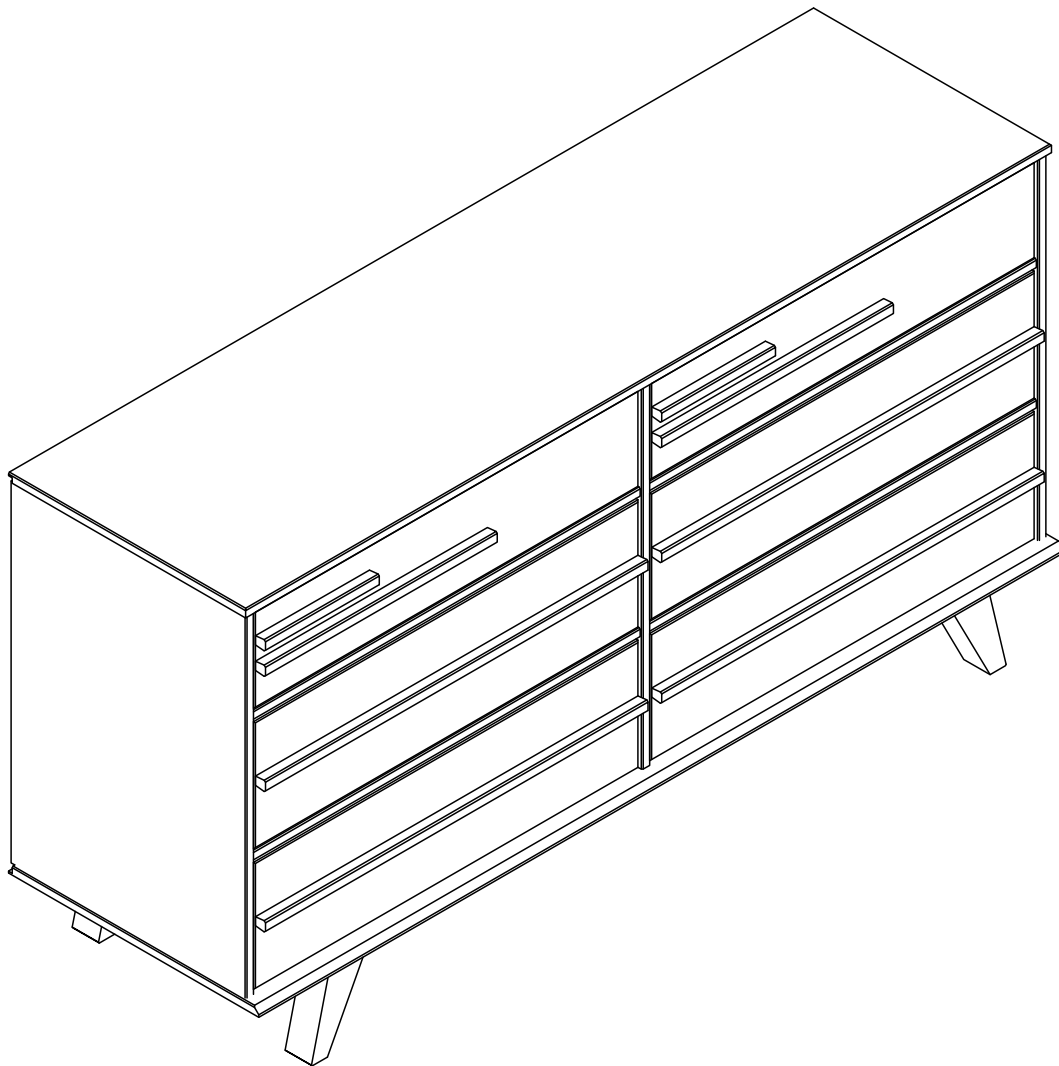

For Residential Use Only

Please visit our website for the most current instructions, assembly tips, report damage, or request parts. www.walker-edison.com

WE Time to get started

Set up a clean and soft workplace to avoid damage during assembly. You can use the box and internal protections as cover. It also helps to double-check if you've got all the pieces and parts before diving in assembly.

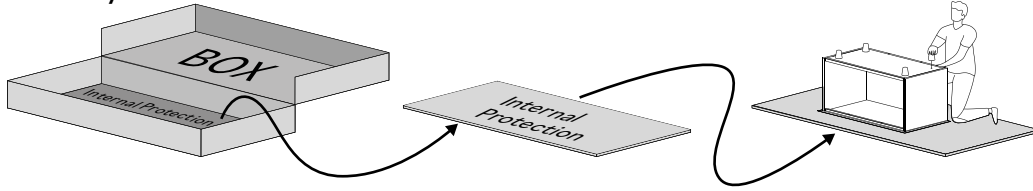

Estimated time for assembly

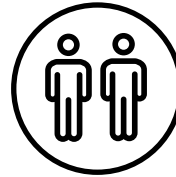

2 People Build

People recommended for assembly

Make it a team effort!
Grab a friend for quicker, easier assembly.

Tools Needed

Grab a Phillips head screwdriver to conquer this assembly. We will also need a hammer to help.

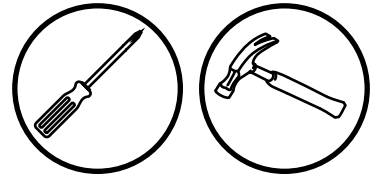

Use power tools with caution

This furniture is made of Solid Wood and Composite Wood, soft materials. If you choose to use power tools, set it to the slower setting. Be careful! Power tools can cause cracking or damage to the furniture, they can also damage the hardware if misused.

Power tool damages are not covered by the Walker Edison warranty.

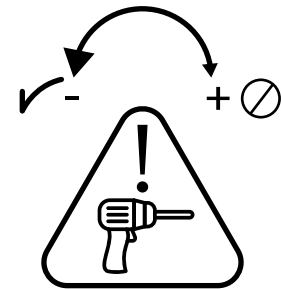

Slide care

Your furniture has highly durable wooden sliders. From time to time we recommend applying paraffin or standard candle wax to improve gliding of the sliders.

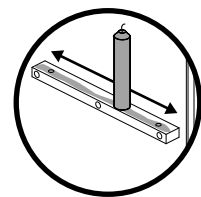

Scan to get assembly tips and help!



Parts List

Part Number	Description	Quantity
1	Top Panel	1
2	Left Side Panel	1
3	Right Side Panel	1
4	Base	1
5	Front Rail	4
6	Division	1
7	Back Panel	2
8	Front Foot Panel	2
9	Side Foot Rail	2
10	Left Foot	2
11	Right Foot	2

Part Number	Description	Quantity
12	Center Foot	1
13	Small Drawer Front	2
14	Large Drawer Front	4
15	Left Drawer Side	6
16	Right Drawer Side	5
17	Wood Slider	12
18	Right Drawer Side with Warning	1
19	Drawer Back	6
20	Drawer Bottom	6
21	Small Drawer Handle	2
22	Drawer Handle	2
23	Large Drawer Handle	4

The side drawer with WARNING LABEL, should be mounted in highest drawer.

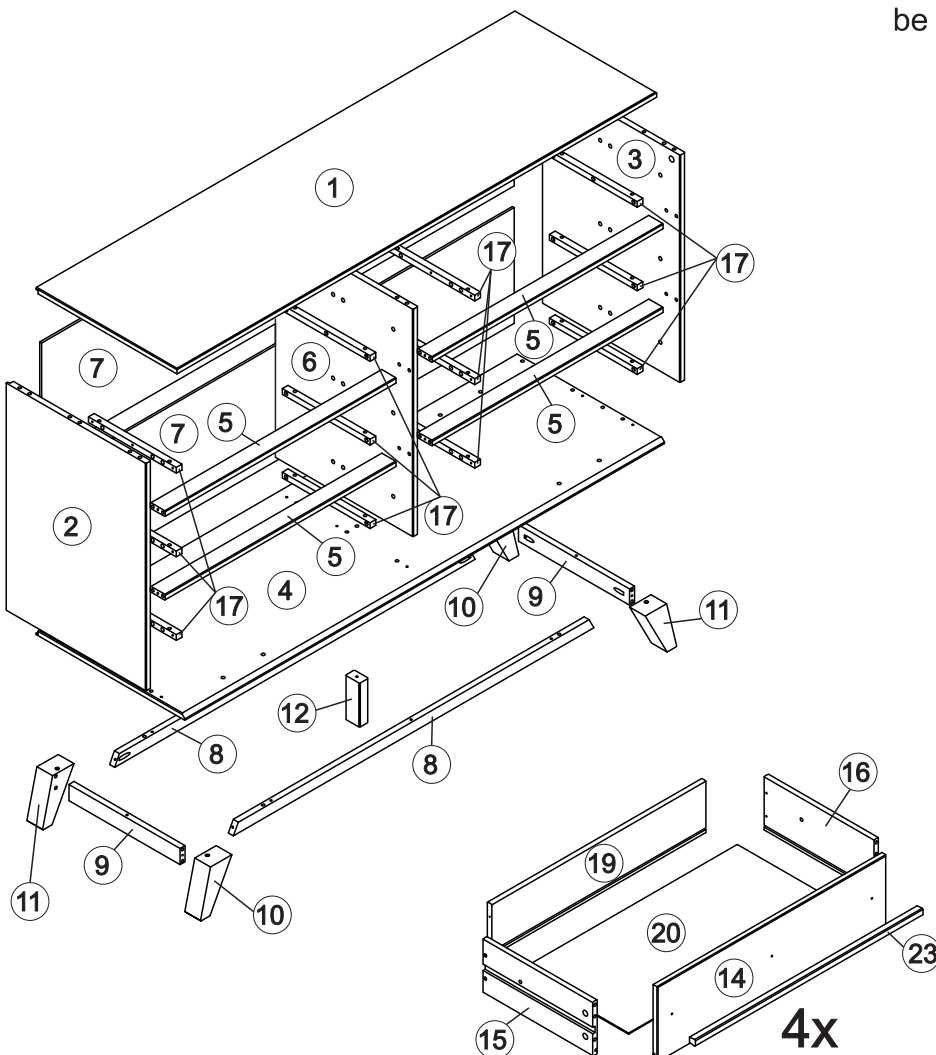

WARNING







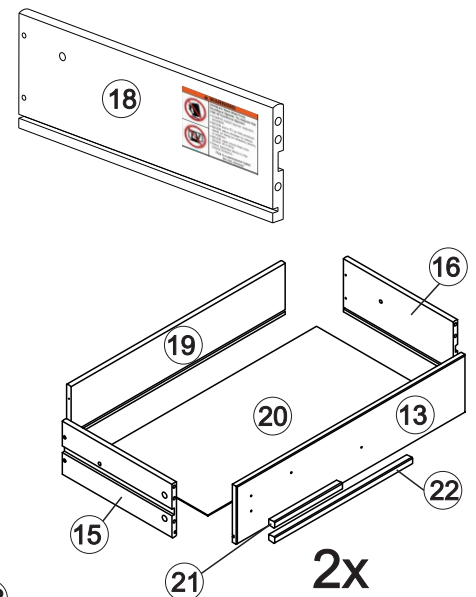



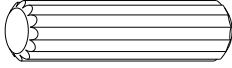
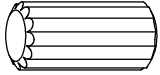

Children have died from furniture tipover. To reduce the risk of furniture tipover:

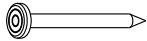
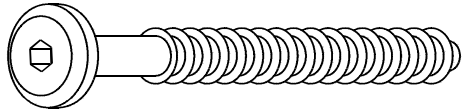
- ALWAYS install Anti-tip device provided.
- NEVER put a TV on this product.
- NEVER allow children to stand, climb or hang on any drawers, doors, or shelves.
- NEVER open more than one drawer at a time.
- Place heaviest items in the lowest drawers.

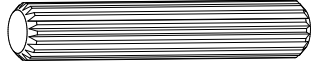
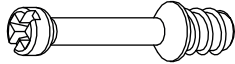
This is a permanent label. Do not remove!

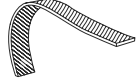

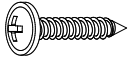
WE Hardware List

Part	Size	Name	Quantity	
A		Ø8*30mm	Wooden dowel	72
B		Ø10*20mm	Wooden dowel	36
C		Ø4,0*25mm	Screw	56
D		Ø3,5*30mm	Screw	40
E		Ø4,0*40mm	Screw	17
F		Ø10*10mm	Nail	36
G		Ø7,0*60mm	Bolt	05
H		4mm	Hex Key	01
I		Ø8*40mm	Wooden dowel	12
J		ø15*30mm	Cam bolt	33
K		ø15*10mm	Cam lock	33
L			Wall anchor	01
M			Washer	02
N		Ø6*35mm		01
O		Ø4*16mm	Screw	01
P		Ø4,0*40mm	Screw	01
Q		1483mm	"H" Profile	01

*The hardware quantities listed above are required for proper assembly.
Extra hardware pieces may be included.*

Step 1

Let's start! Insert Wooden dowels (B) into Wood sliders (17).

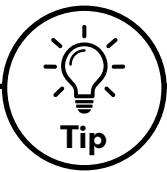
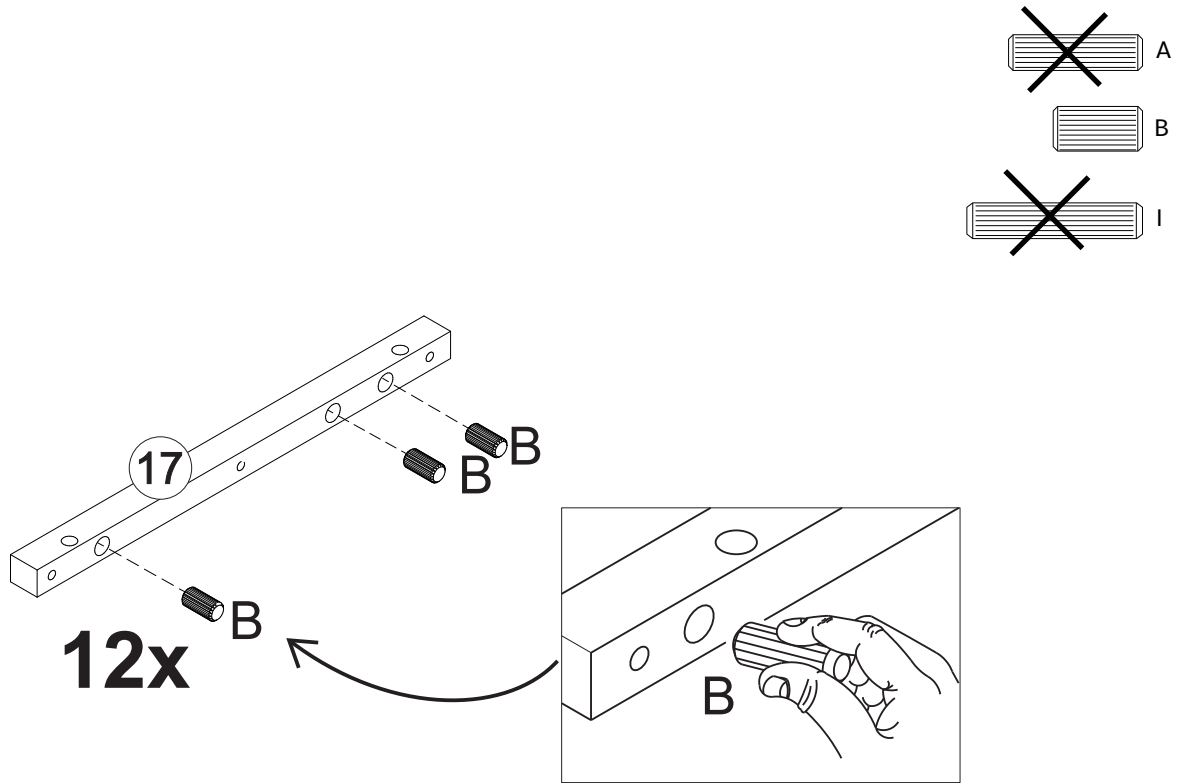

Tip

Wood Dowels

Dowels are essential in furniture assembly to create strong, precise connections. They ensure structural integrity, prevent shifting, and simplify alignment, resulting in sturdier, longer-lasting furniture.

Follow these steps:

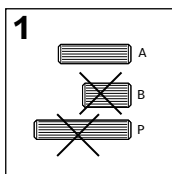

1: Select the appropriate size dowel according with step.

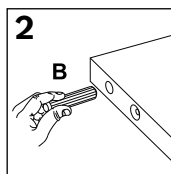

2: Insert into drilled hole and press firmly to ensure placement is set.

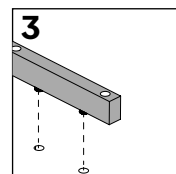
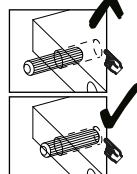

3: Align the dowel with corresponding piece and press together until secure.

Step 2

Also insert Wooden dowel (A) into Left side panel (2), Right side panel (3), Front rail (5), Division (6), Front foot rail (8), Side foot rail (9), Left drawer side (15), Right drawer side (16) and Right drawer side with warning (18).

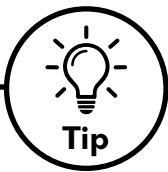
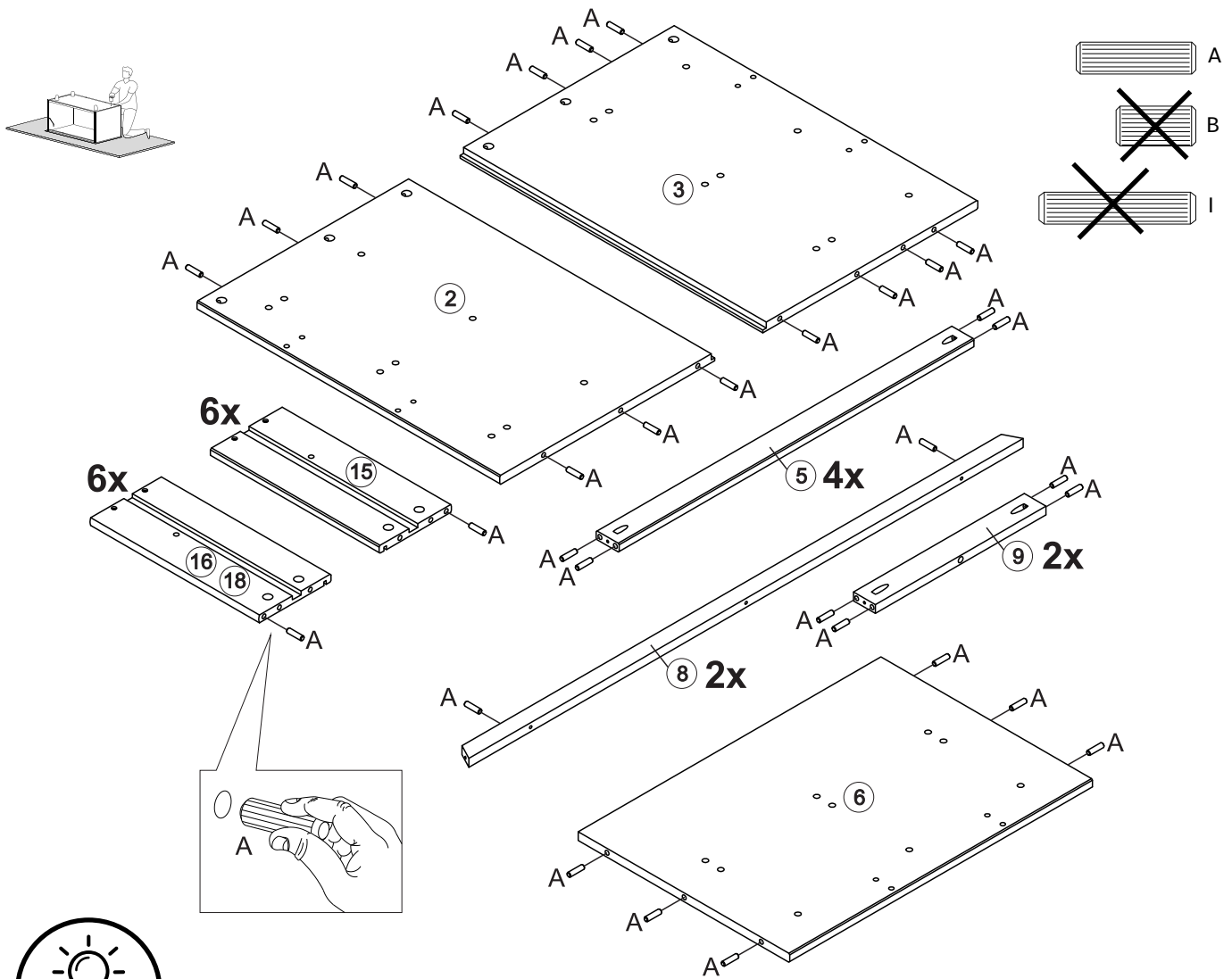

Tip

To keep your product looking its best and scratch-free, try assembling it on a soft surface like carpet or a blanket. This helps prevent any accidental scratches and keeps your furniture in top shape!

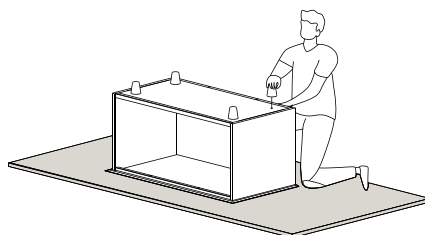

Step 3

Attach the Cam bolt (J) into Top panel (1), Small drawer front (13) and Large drawer front (14) using a Phillips head screwdriver.

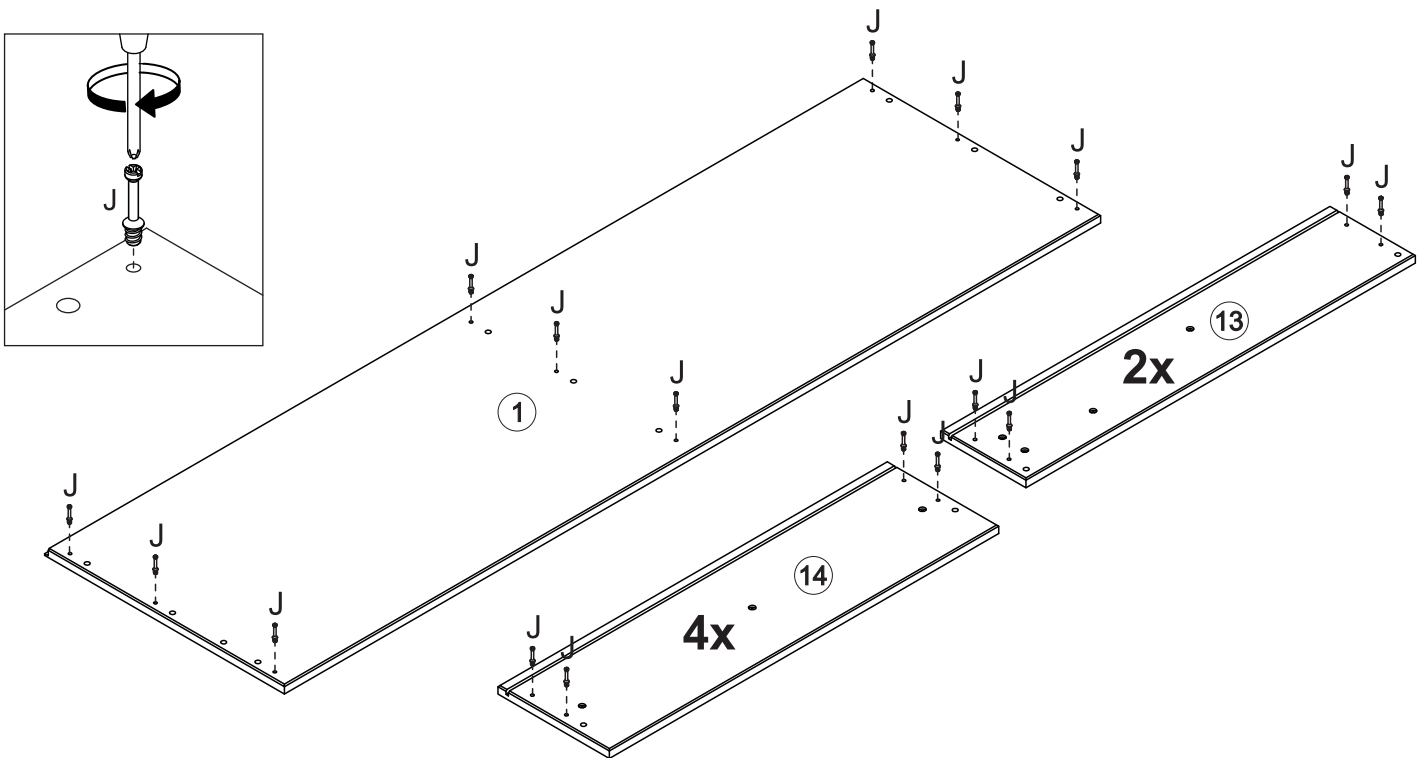

Step 4

Secure Wood sliders (17) to Left side panel (2) and Right side panel (3) using Screw (C) and a Phillips head screwdriver.

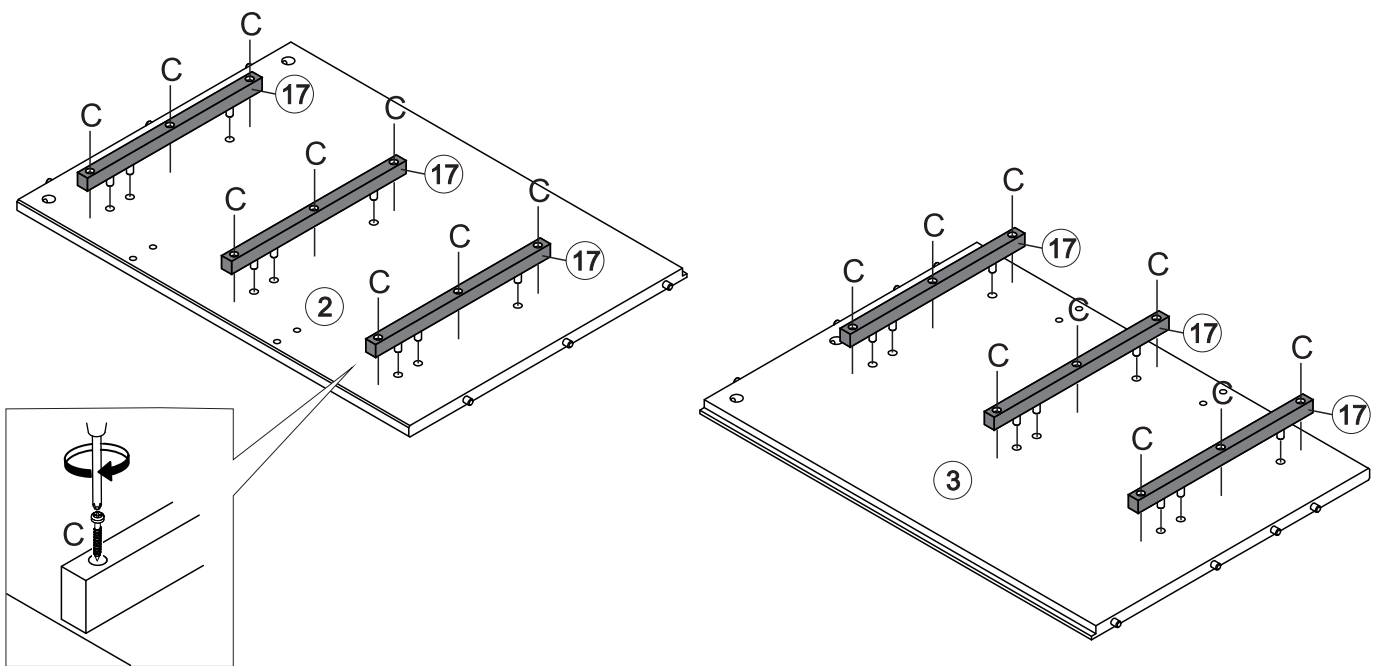
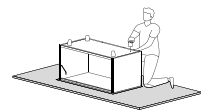

Step 5

Secure Wood slider (17) to both sides of Division (6) using Screw (C) and a Phillips head screwdriver.

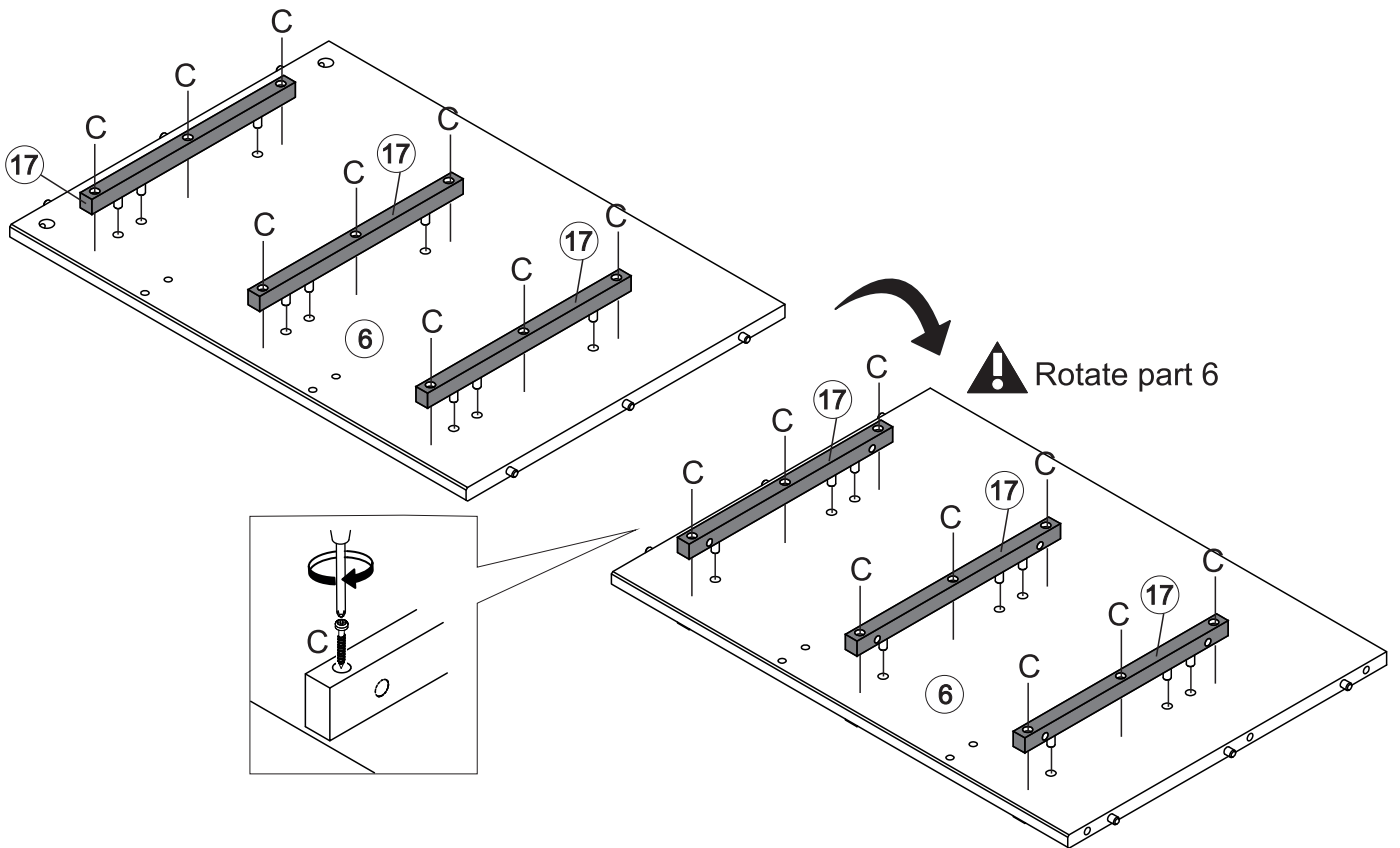
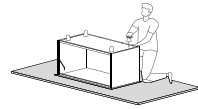

Step 6

Join Front rail (5) to Left side panel (2), Right side panel (3) and Division (6), using Screws (D) and a Phillips head screwdriver.

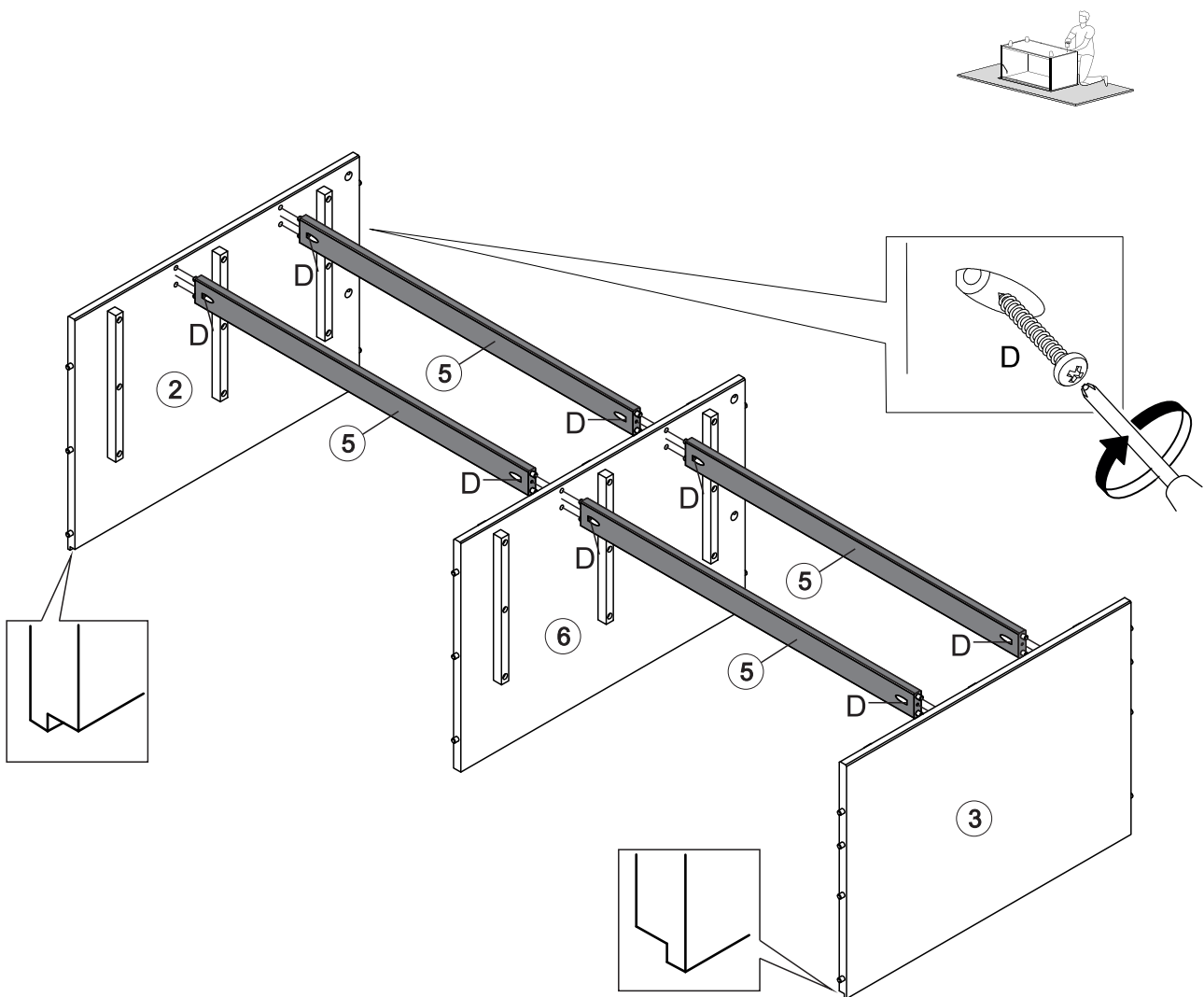

Step 7

Attach Side foot rail (9) to Left foot (10) and Right foot (11) using Screw (D) and a Phillips head screwdriver.

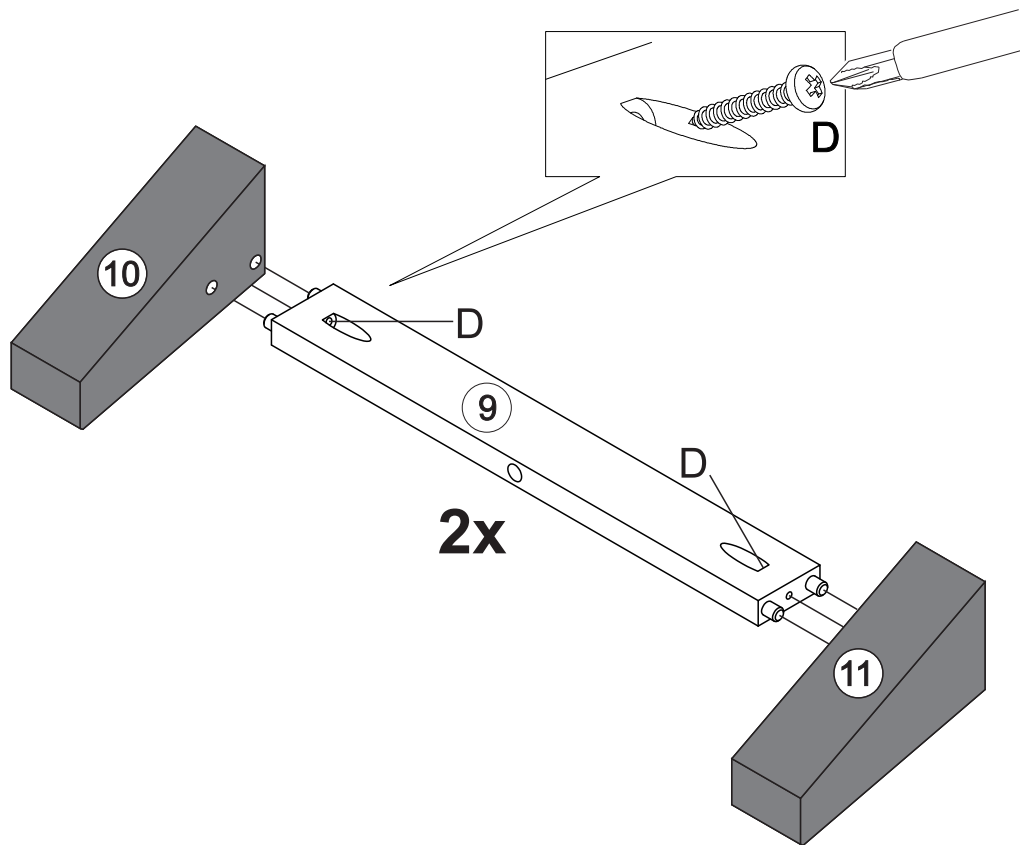
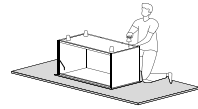

Step 8

Attach Front foot rail (8) to Base (4) using Screw (E) and a Phillips head screwdriver.

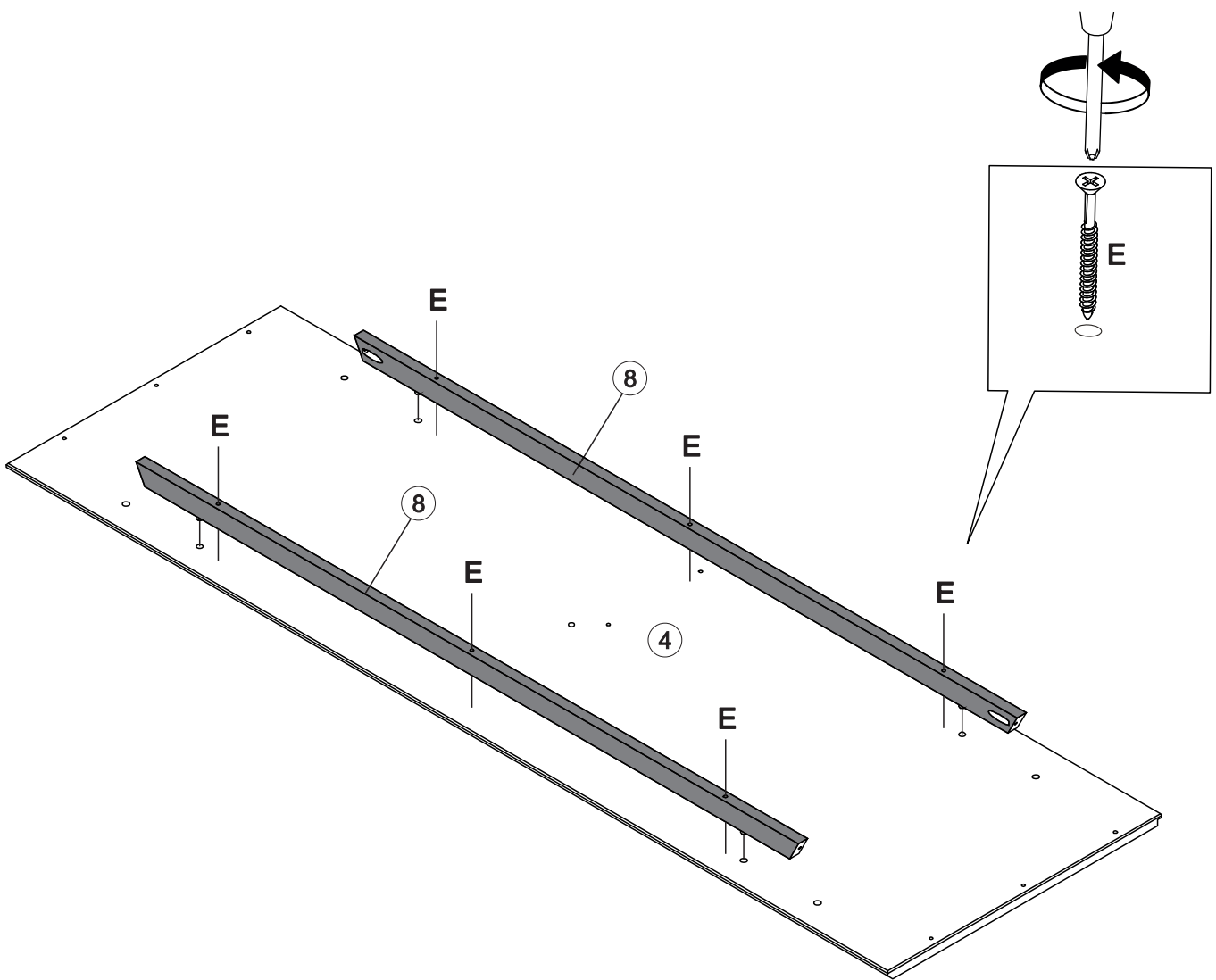
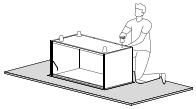

Step 9

Secure the legs you assembled previously and Center foot (12) to Base (4) using Bolts (G) and Hex key (H). Leave Bolts (G) a little loose for future steps.

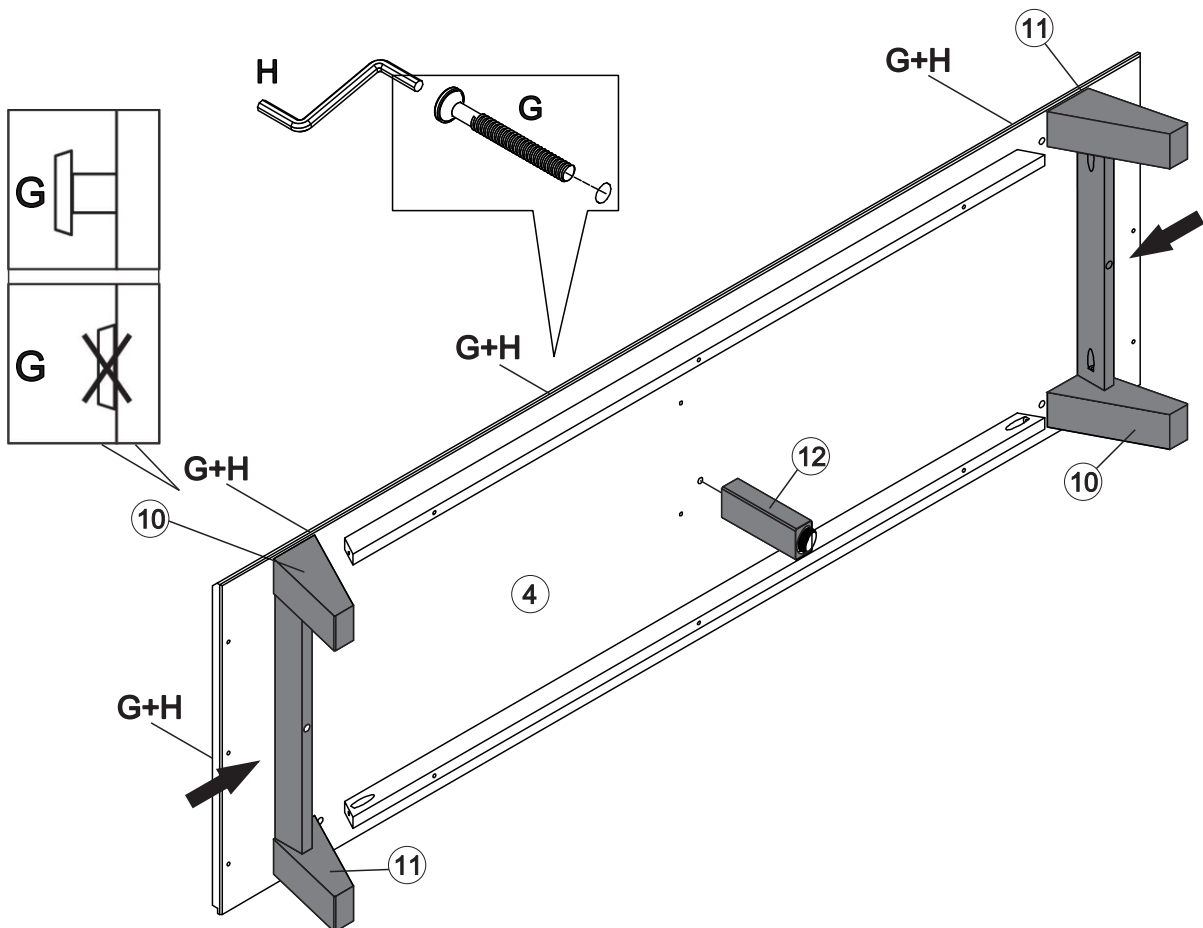
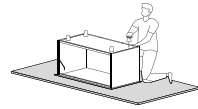

Step 10

Join Front foot rail (8) to Left foot (10) and Right foot (11) using Screw (D) and a Phillips head screwdriver.

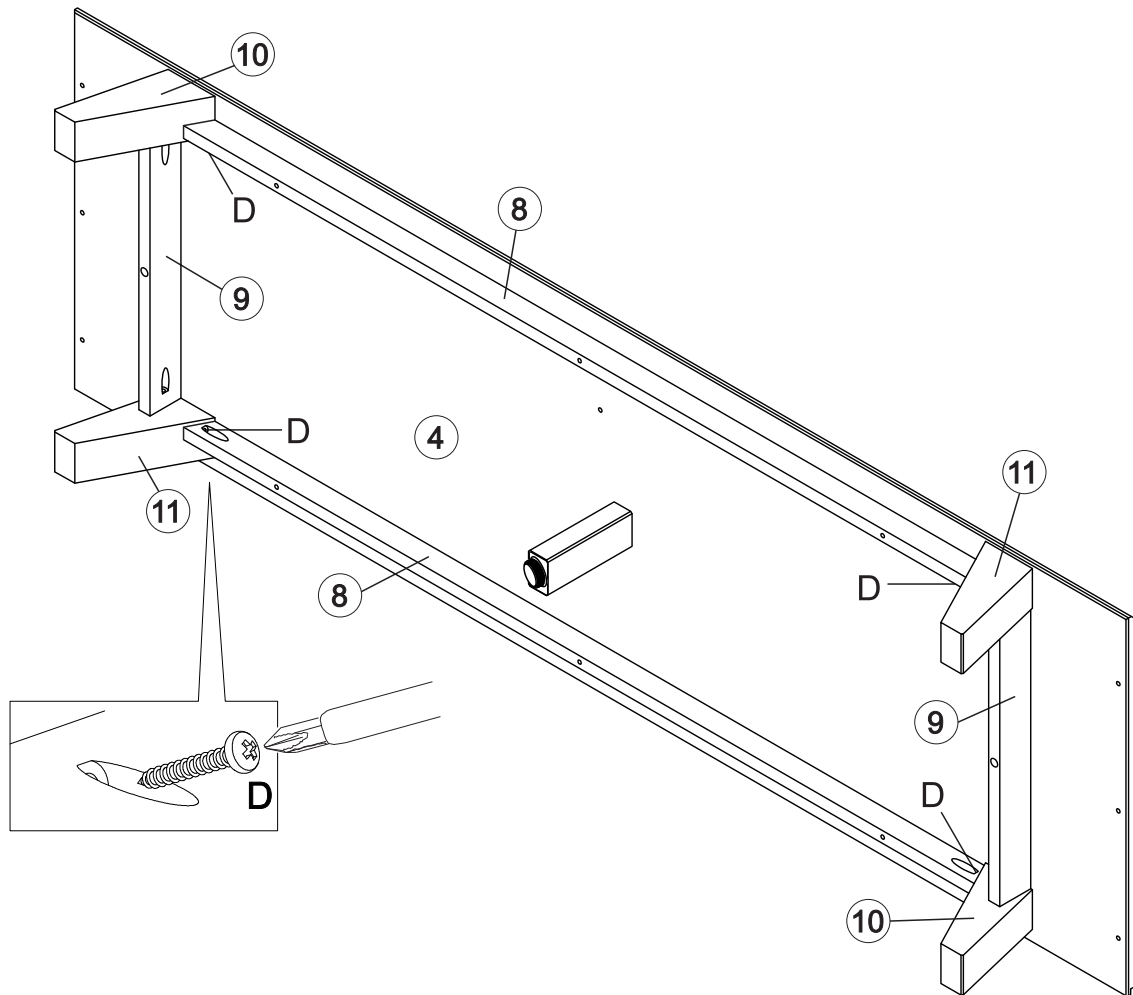

Step 11

Attach Base (4) to Left side panel (2), Right side panel (3) and Division (6) using Screw (E) and Phillips head screwdriver.

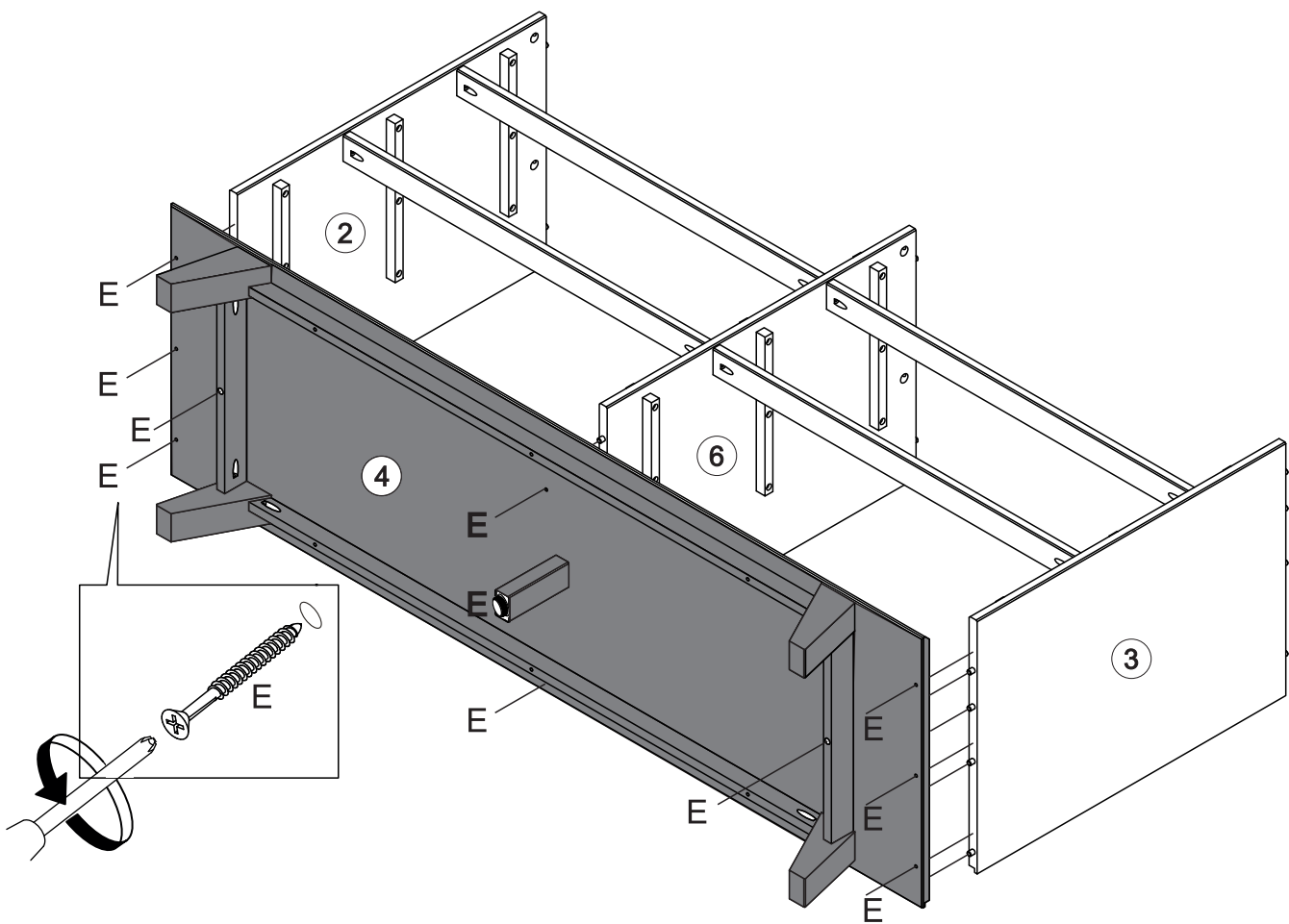
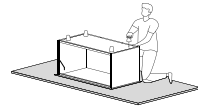

Step 12

Secure Top panel (1) to Left side panel (2), Right side panel (3) and Division (6) using Cam lock (K) and a Phillips head screwdriver.

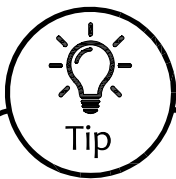
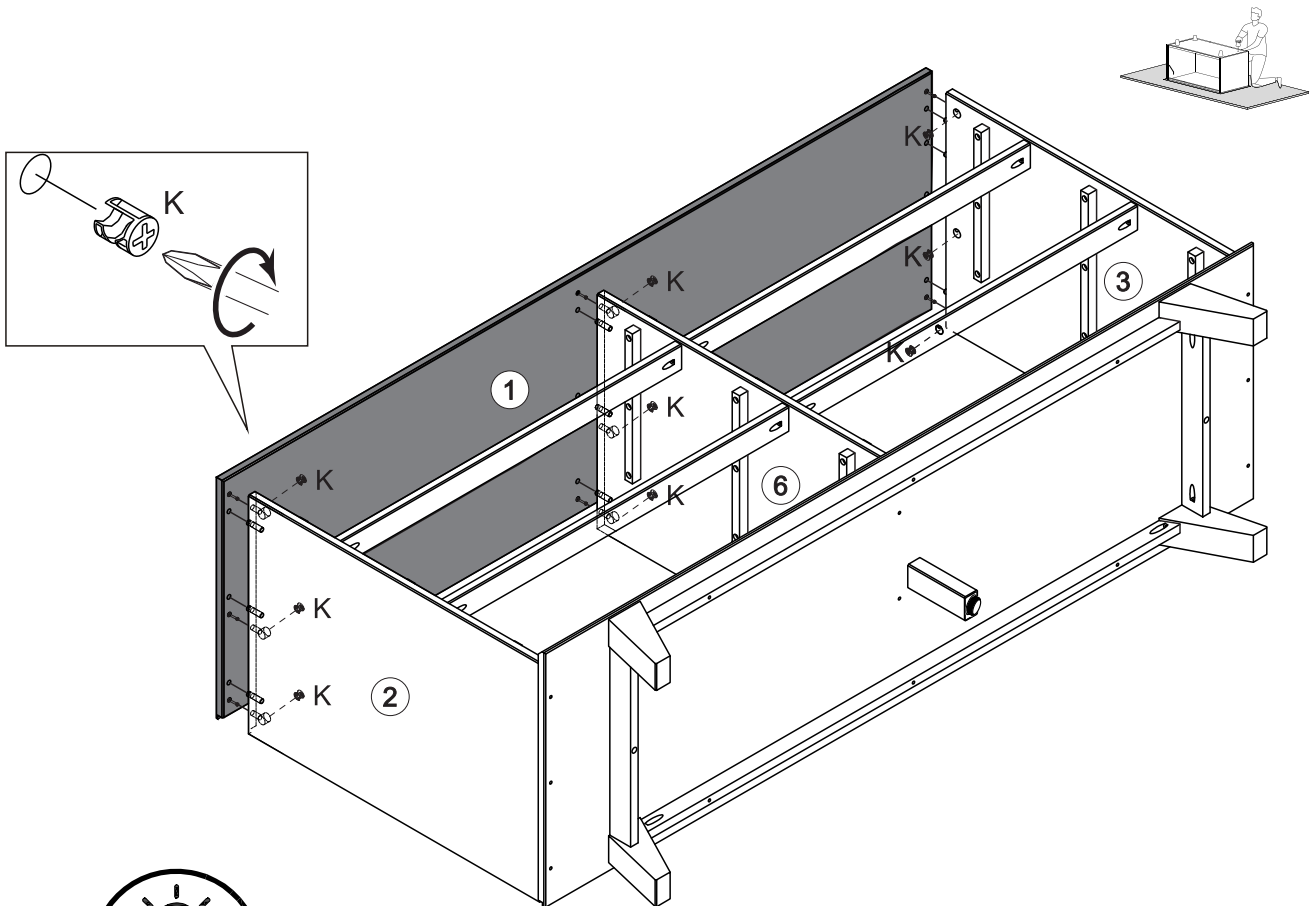

Cam Locks

Cam Locks help securely join two pieces together.
Follow these easy steps.

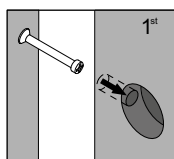

1: Insert Cam Bolt into bolt holes on the flat side. Don't over tighten!

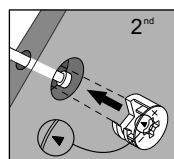

2: Assemble both parts together. The cam bolts goes in the drills holes that have a circular hole on the side, you should be able to see the cam bolt through it. After fitting parts together insert the cam lock on the side holes.

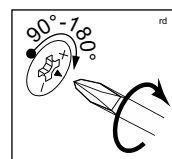

3: On the back of the Cam Lock will be a "C" shape. Insert the Cam Lock so the opening of the "C" fits over the Cam Bolt. Tighten with the screwdriver.

Step 13

Insert Wooden Dowel (A) into Wood Slider (17) front hole.

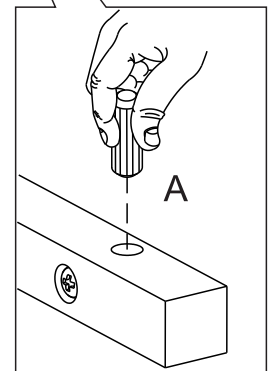
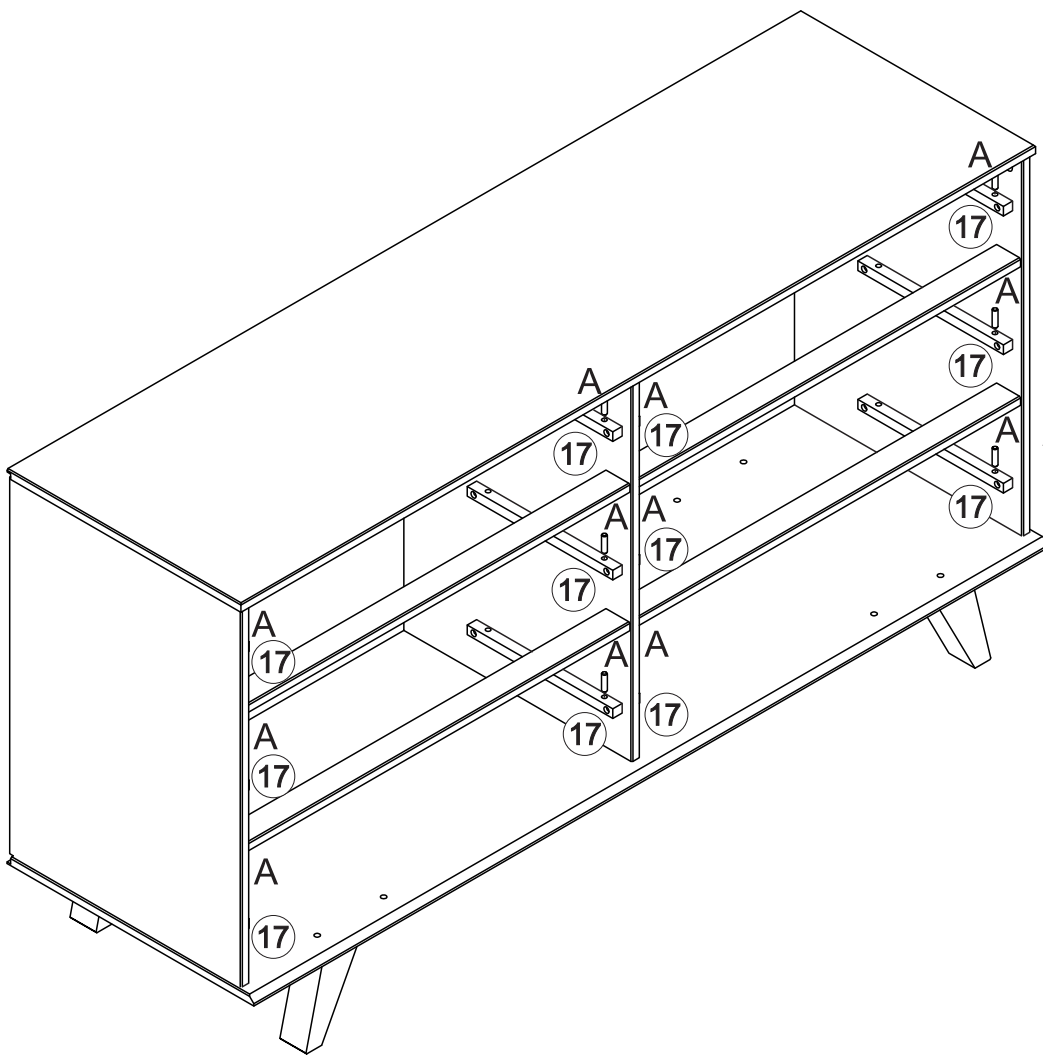
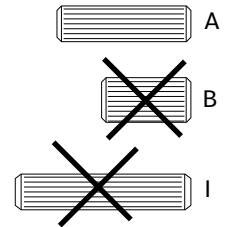

Step 14

Secure Back panel (7) to your dresser using H Profile (Q), Nails (F) and a hammer.

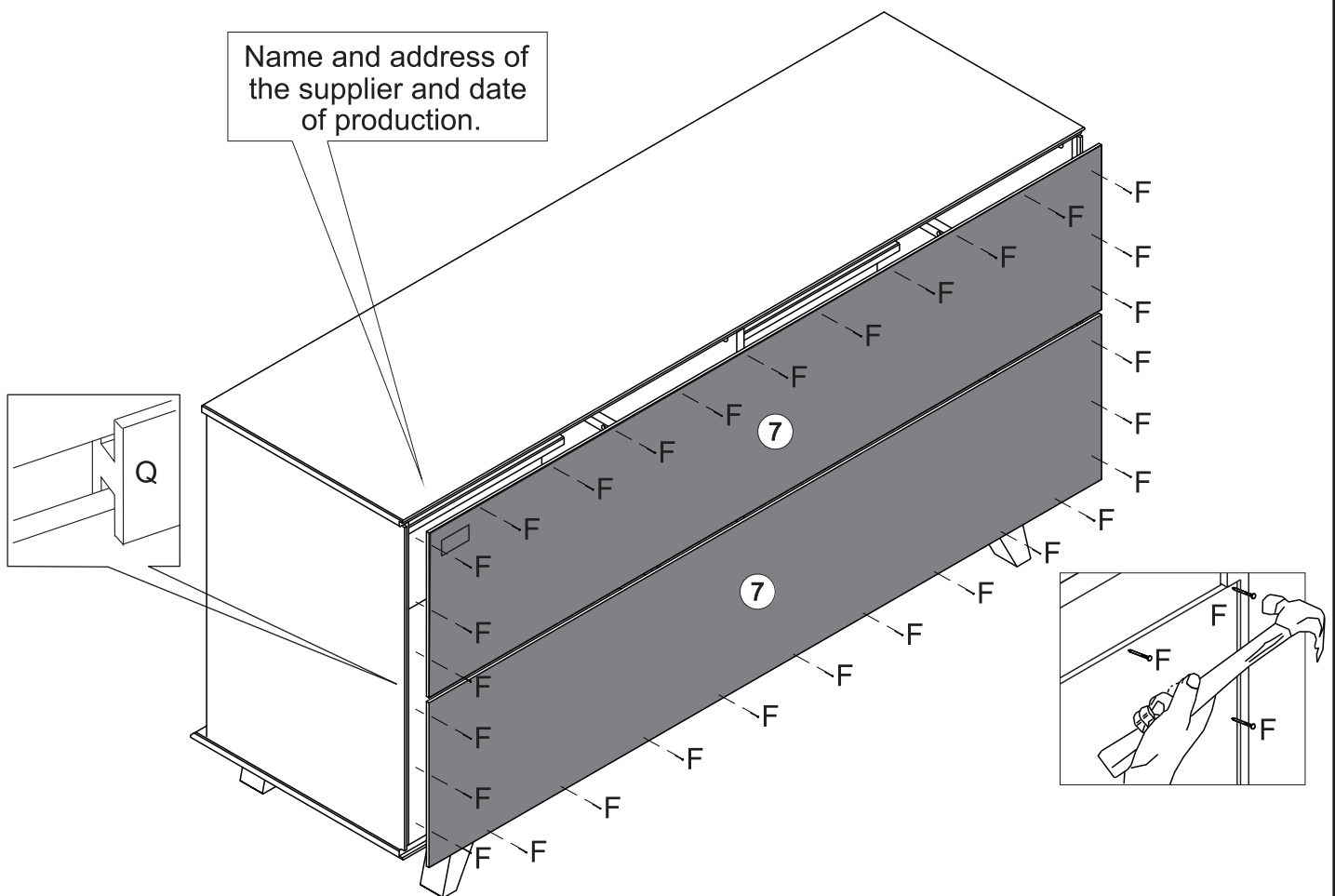

Step 15

Secure Back panel (7) to Division (6) using Nails (F) and a hammer

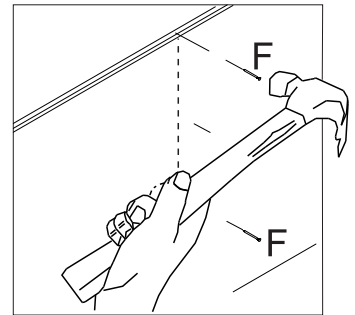
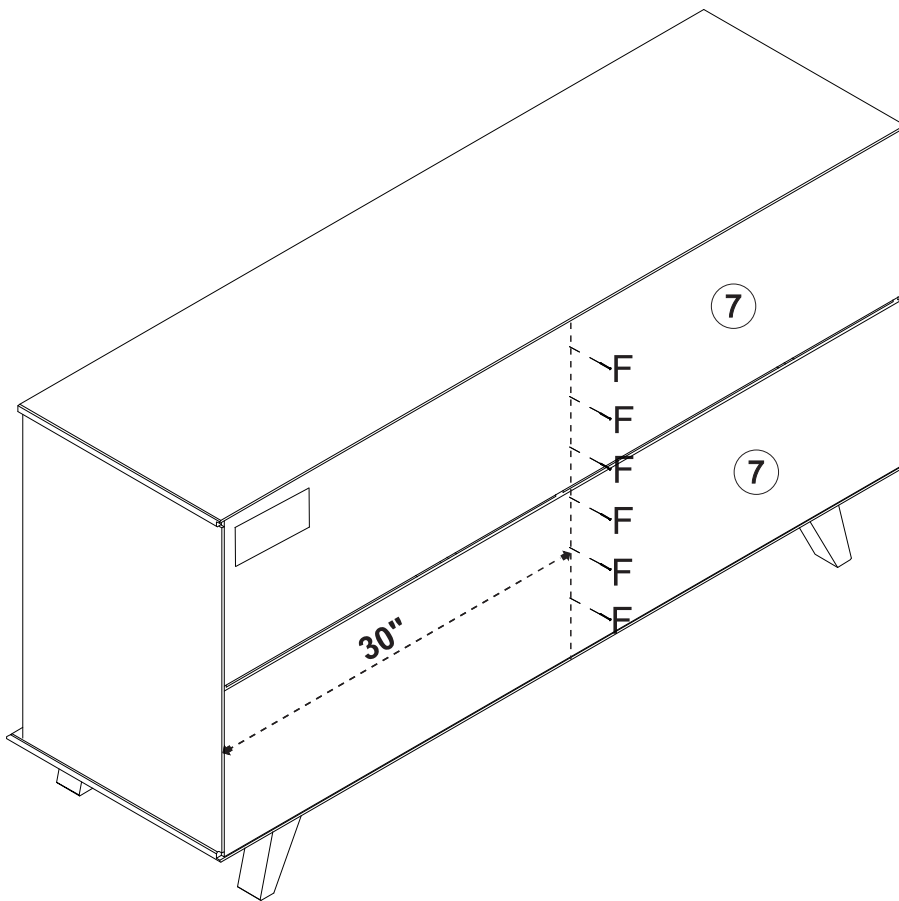

Step 16

Let's assemble the drawers! Attach Small drawer handle (21) and Drawer handle (22) to Small drawer front (13), and Large drawer handle (23) to Large drawer front (14) using Screws (C) and a phillips head screwdriver.

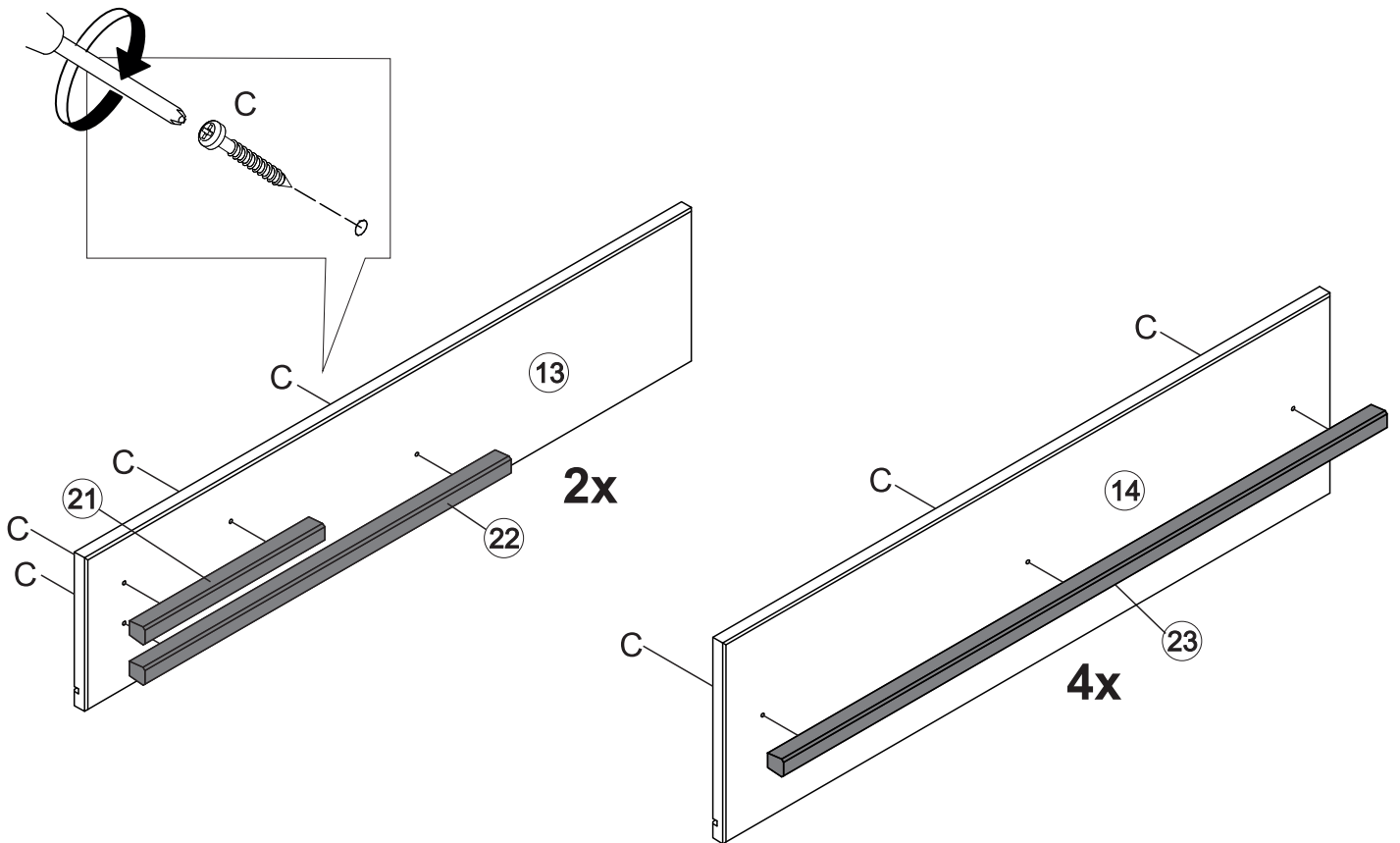

Step 17

Fit the Cam bolts (J) on Small drawer front (13) to Left drawer side (15), Right drawer side (16) and Right drawer side with warning (18) and attach with Cam lock (K) and a philips head screwdriver.

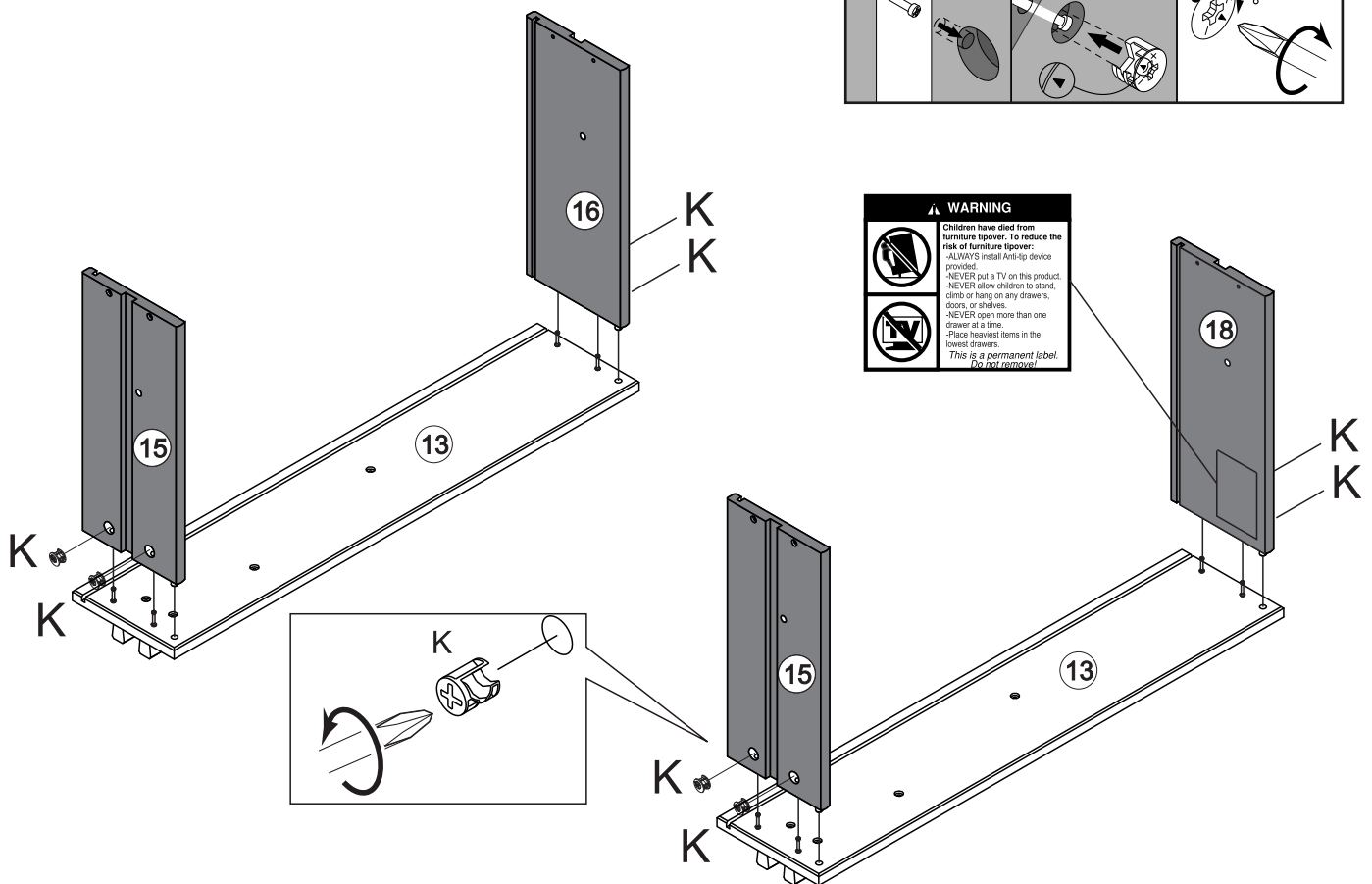
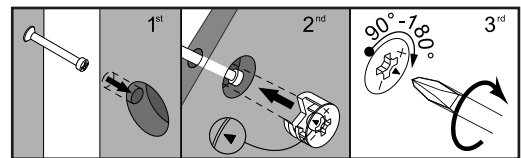
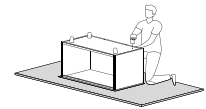

Step 18

Slide Drawer bottom (20) on the grooves on Right and Left drawer sides (15,16/18) fitting on Drawer front (13). Attach Drawer back (19) to Right and Left drawer side (15,16/18) using Screws (D), and a Phillips head screwdriver.

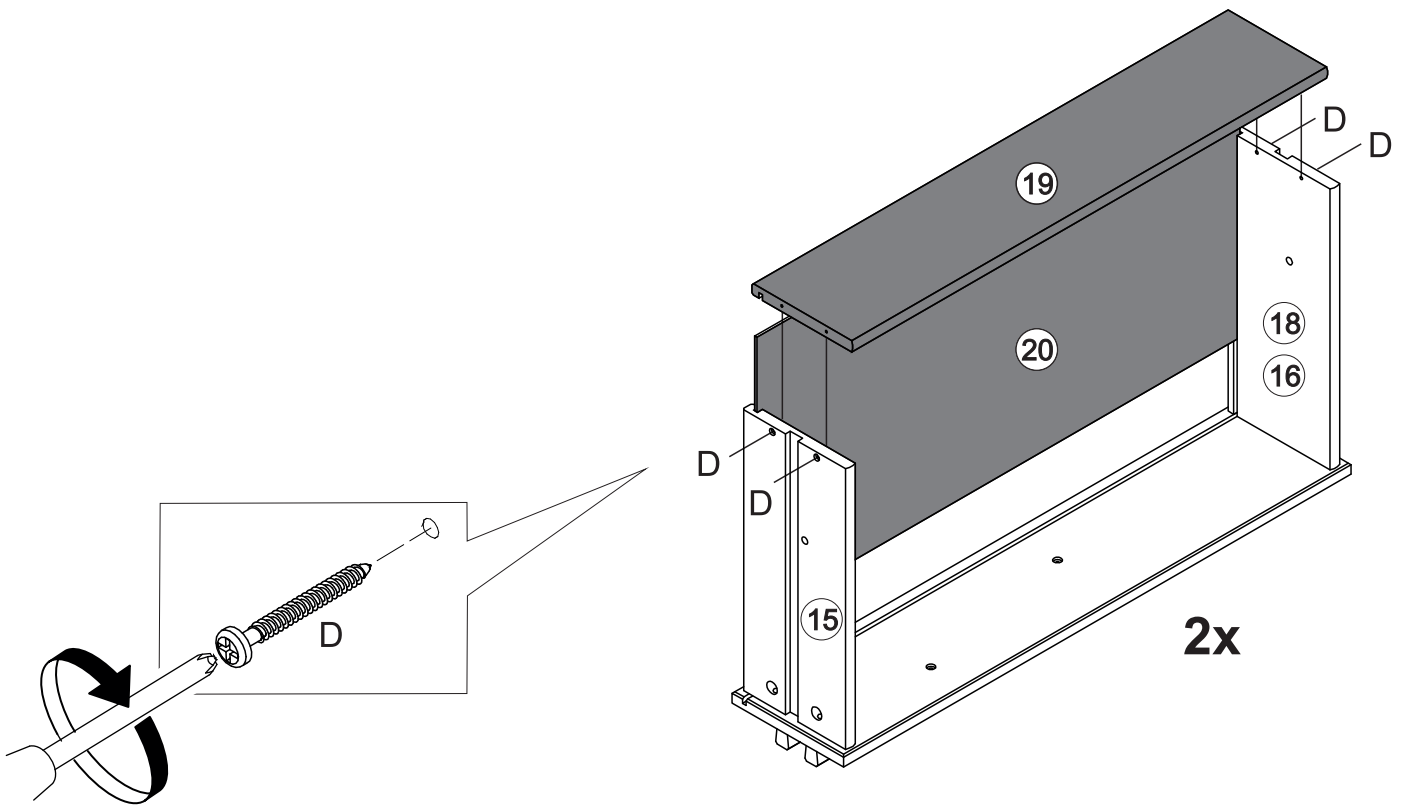

Step 19

Assemble the large drawers by fitting the Cam bolts (J) on Large drawer front (14) to Left drawer side (15), Right drawer side (16) and attach them with Cam lock (K) and a Philips head screwdriver.

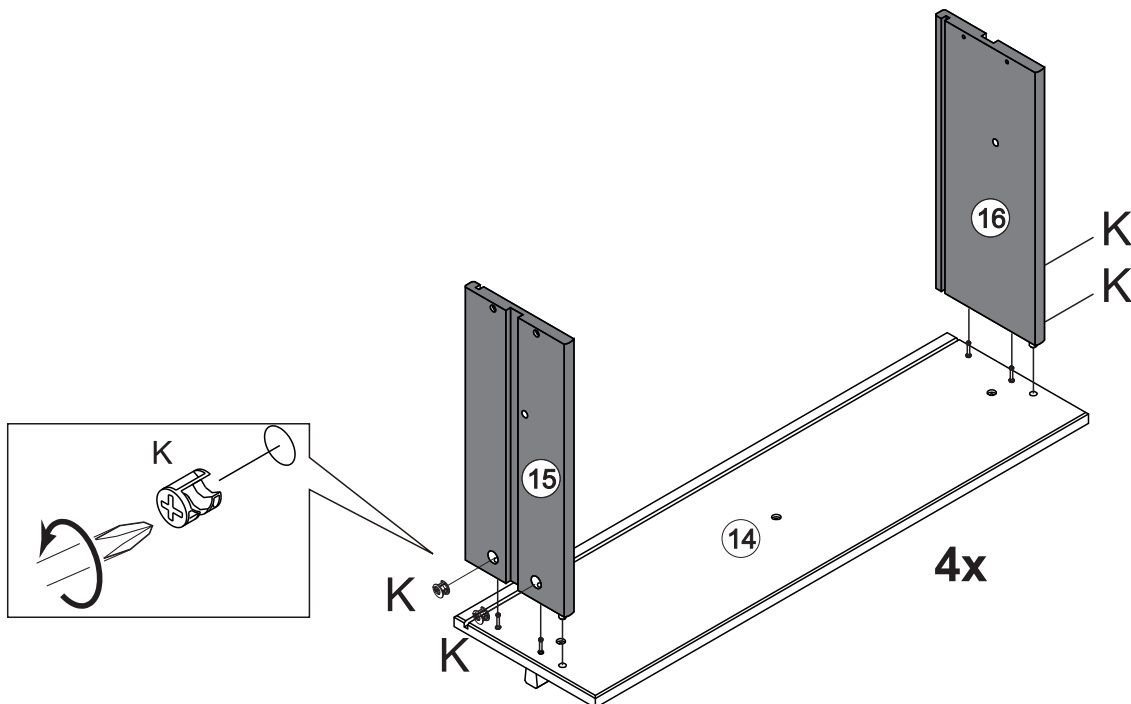
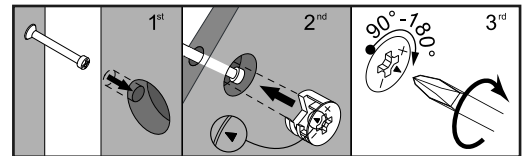
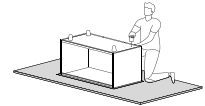

Step 20

Slide Drawer bottom (20) on the grooves on Right and Left drawer sides (15,16) fitting on Drawer front (14). Attach Drawer back (19) to Right and Left drawer side (15,16) using Screws (D), and a Phillips head screwdriver.

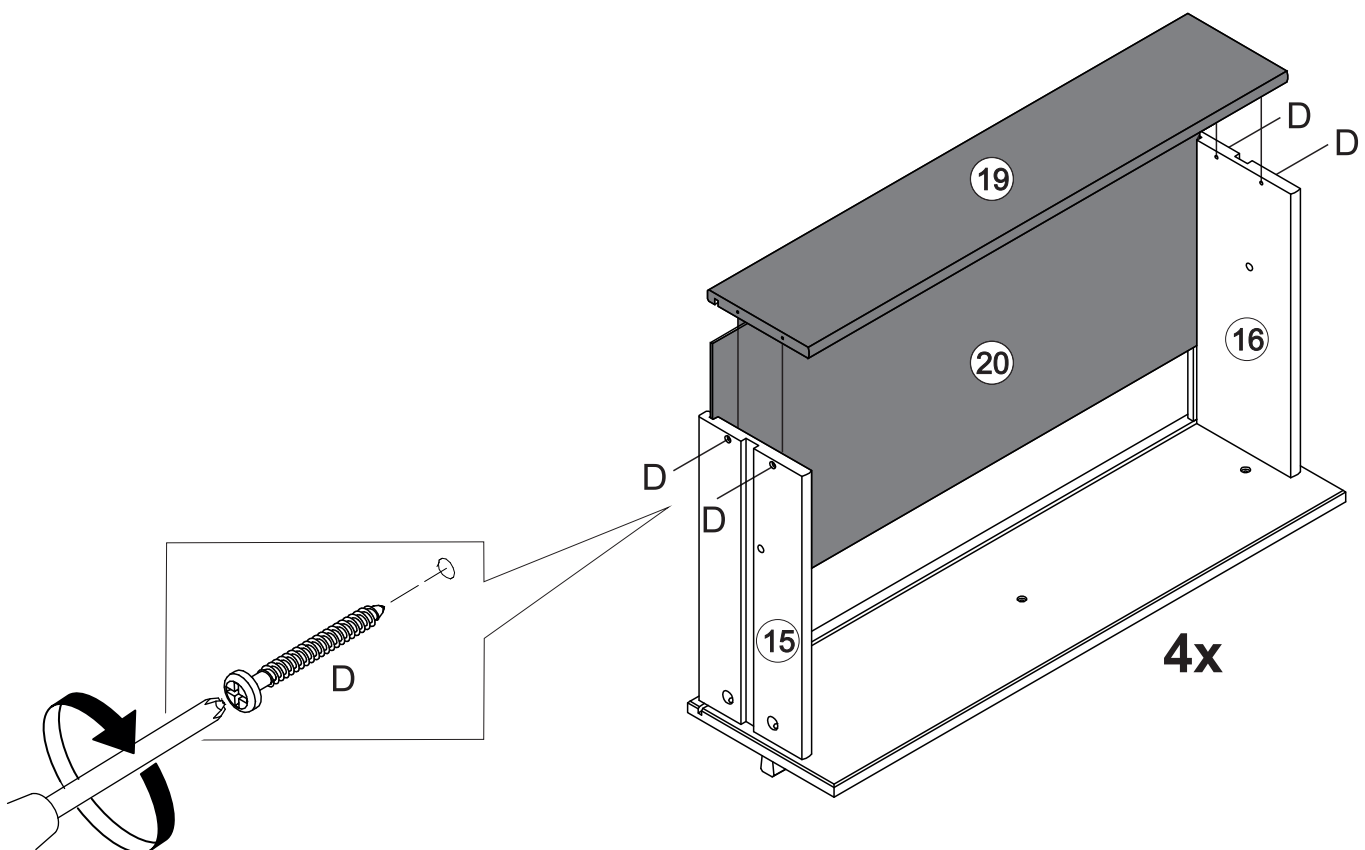
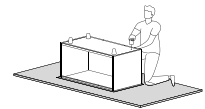

Step 21

Insert Wodden Dowel (I) on the inside of all drawers, with the drawer inside the unit, after having passed the wooden dowel that is in the Drawer Slider (17).

The dowel is not flush with the panel, it is a little inside the drawer to help when you need to remove the lock dowel to remove the drawer.

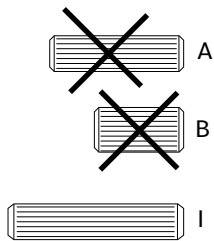

The assembled drawer with this warning must be placed on top of the unit.

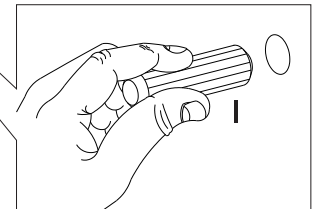
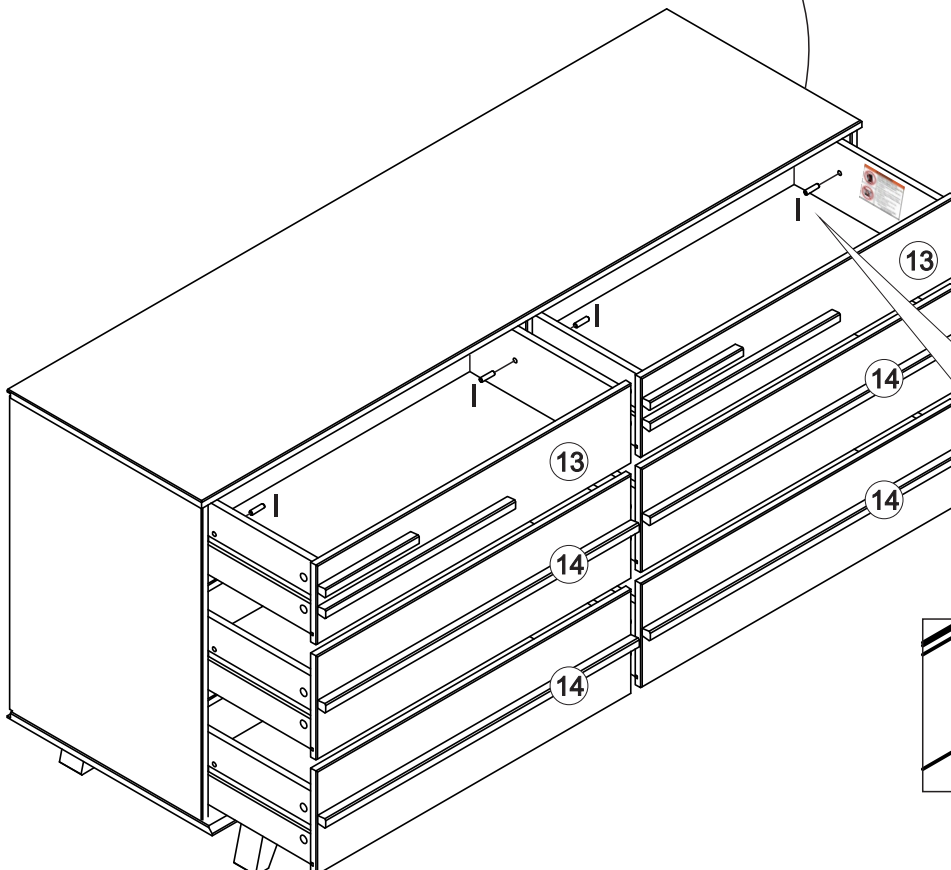

Step 22

To finish this up, let's secure your dresser to the wall!
Attach the Wall Anchor (L) to your dresser with a Washer (M)
and a Screw (O) using a Phillips Head Screwdriver.

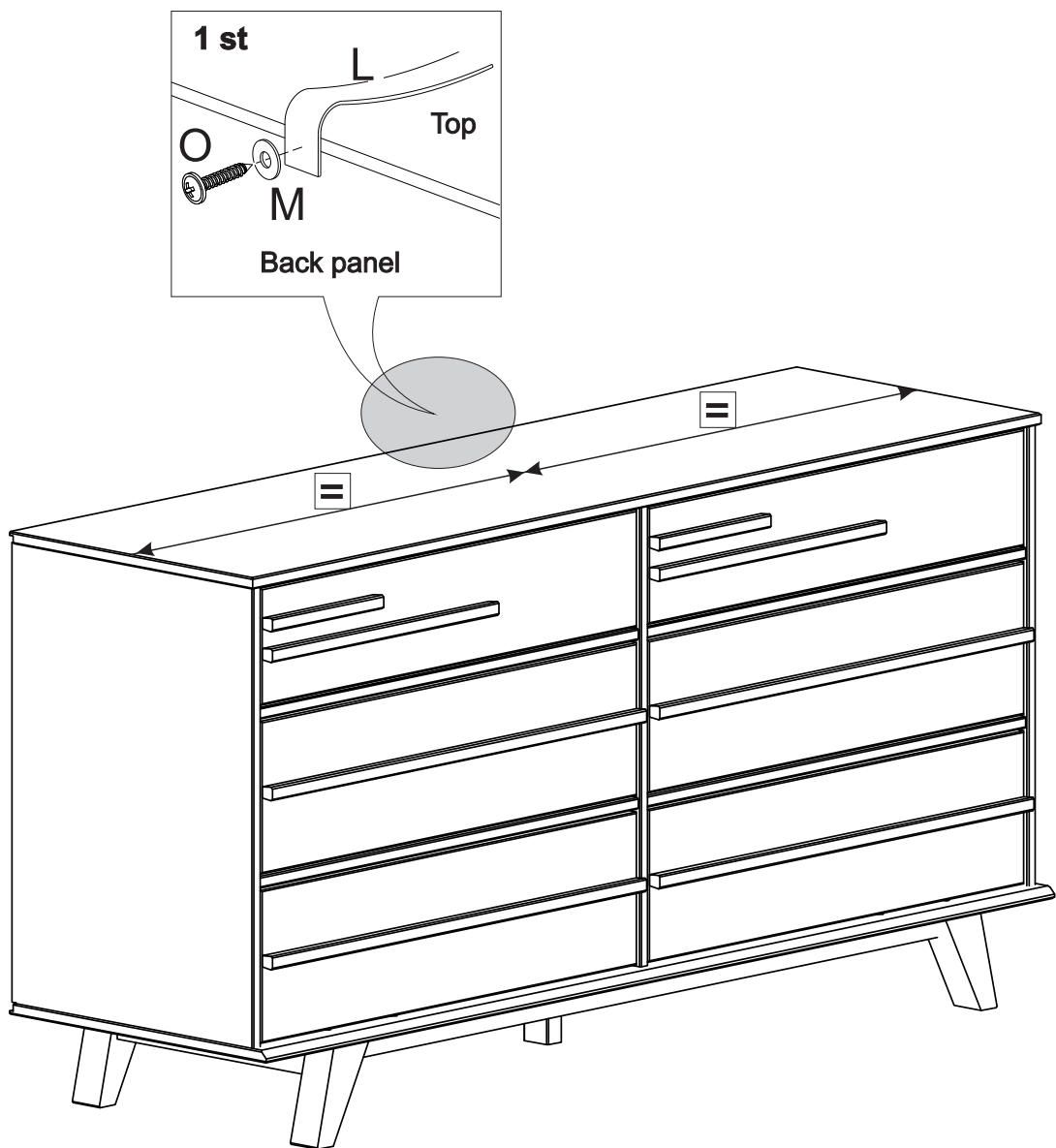

Step 23

Insert the Plastic bush (N) into the wall. Then, secure the Wall Anchor (L) to the wall using a Washer (M) and Screw (P).

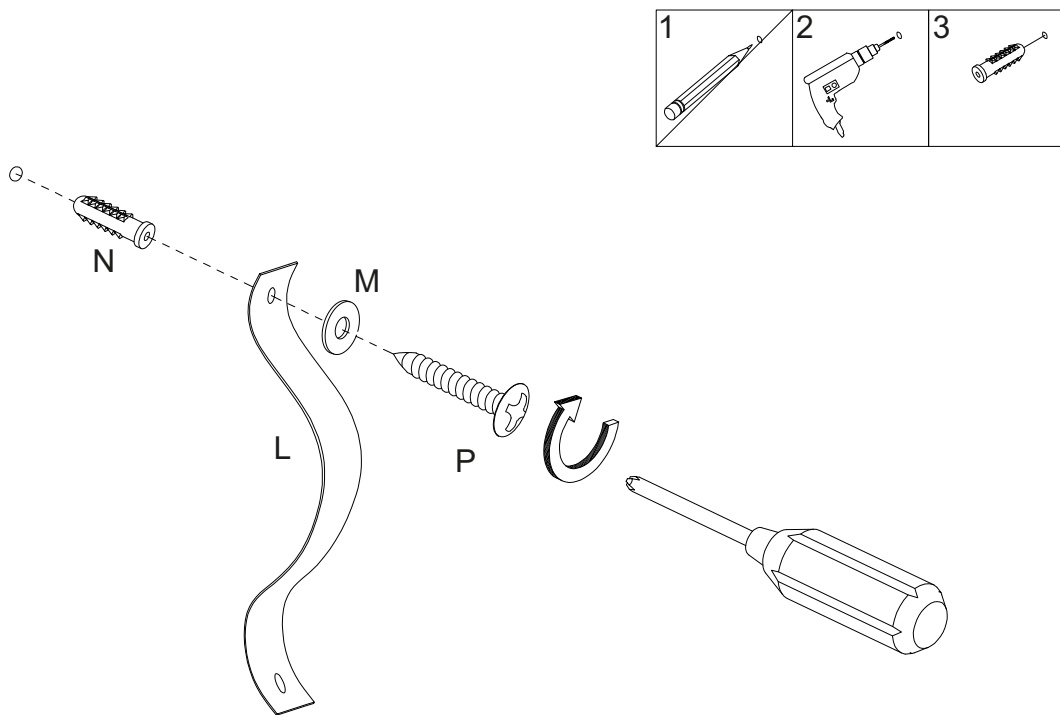

Warning

Serious or fatal injuries can occur from furniture tipping over. To prevent the furniture from tipping over we recommend that it is permanently fixed to the wall. Wall anchor and hardware are included with this product. Please make sure hardware is suitable for your walls before installing, as different wall materials may require different types of anchors.

Name and address information for the manufacturer responsible for the anti-tip hardware and date of production can be found on the label on the back of the furniture.

You did it! Enjoy your new Dresser!

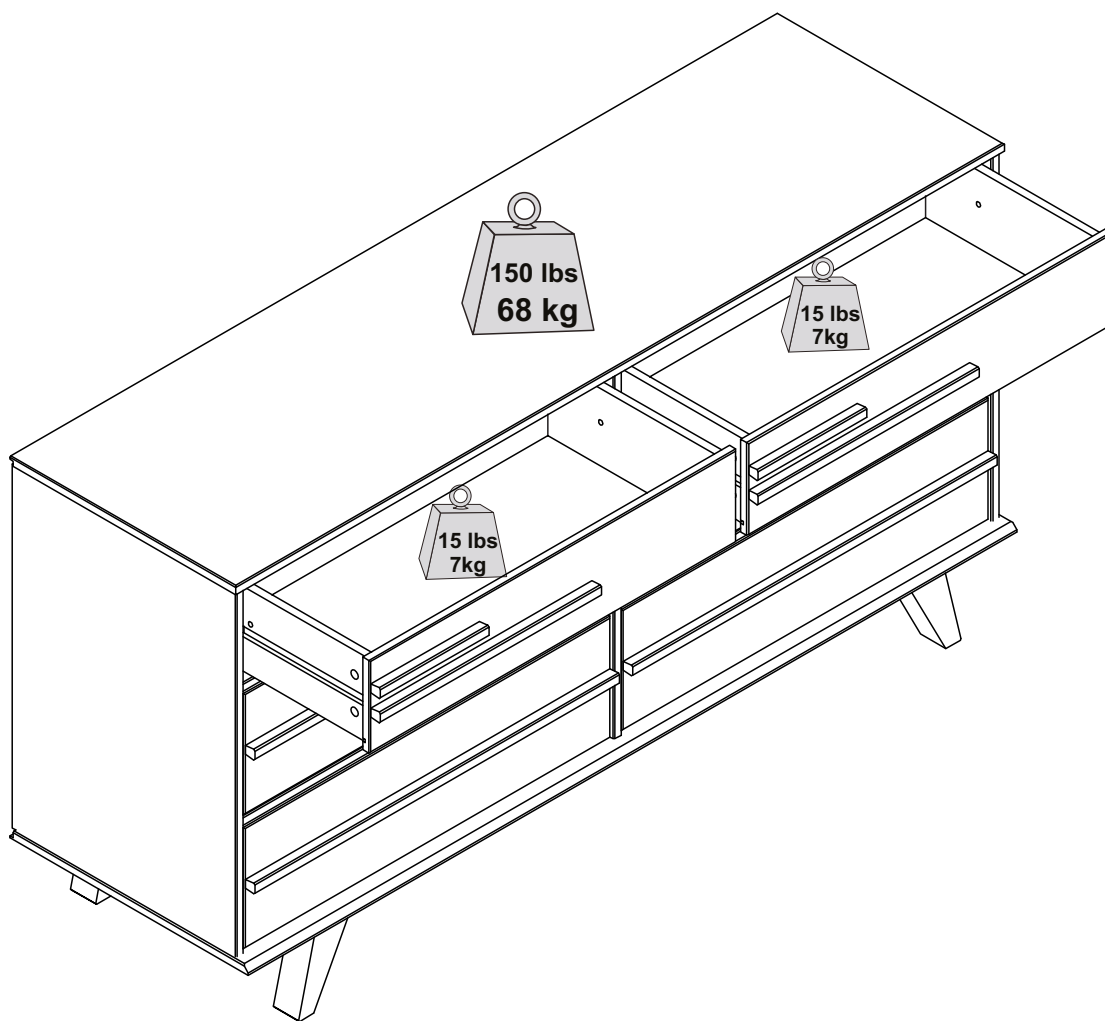

Congratulations on you new piece of furniture!

We would love to hear about it and see it.

Please leave us a review or post a picture with

#mywalkerredisonhome

Assembling furniture can be tricky sometimes.

Our customer service team, located in Utah, is here for product information, help assembling a product, or for any other customer support issue

Call us at **801-433-3008**

Email us at service@walkeredison.com

Visit our Customer Service website at walkeredison.com/pages/customer-service

We are available to help Monday-Thursday 8am-5pm, Friday 8am-3pm MST

For details on Assembly Videos, Assembly Instructions, Replacement Parts, and Customer service,

SCAN HERE

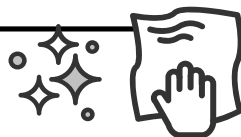

For cleaning, never use abrasives, use a soft cloth and water with neutral soap to clean the furniture.

WALKER EDISON™

Rebecca Commode moderne à 6 tiroirs en bois massif

Rebecca Cómoda moderna de madera maciza con 6 cajones

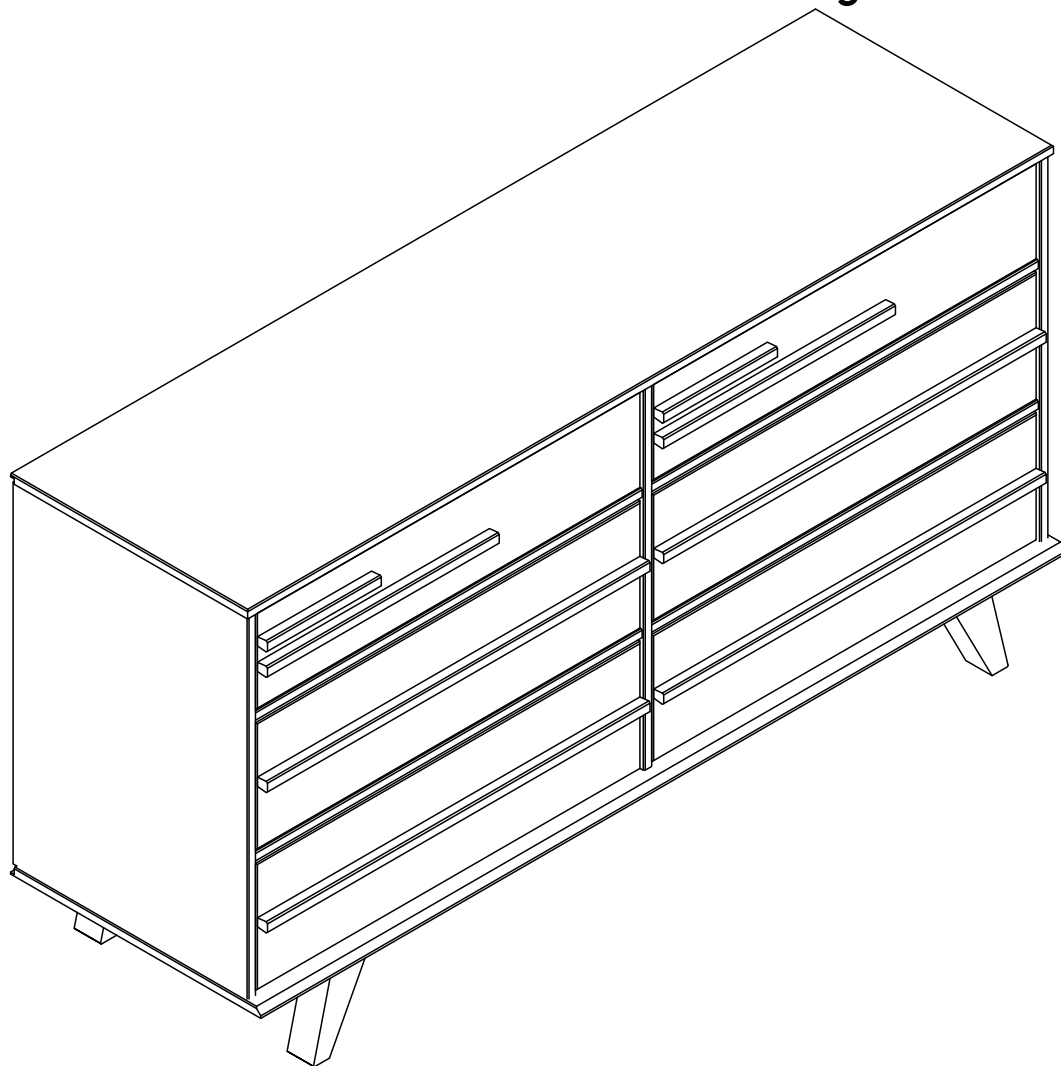

Pour usage résidentiel seulement

Visite notre site Web pour obtenir les instructions les plus récentes, des conseils d'assemblage, signaler des dommages ou commander des pièces. www.walkerredison.com

Sólo para uso residencial

Visite nuestro sitio web para consultar las últimas instrucciones, consejos de montaje, notificar daños o solicitar piezas. www.walkerredison.com

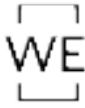

Il est temps de commencer / Hora de empezar

Prépare un lieu de travail propre et souple pour éviter tout dommage lors de l'assemblage. Tu peux utiliser la boîte et les protections internes comme base. Vérifie également que tu disposes de toutes les pièces et parties avant de te lancer dans l'assemblage.

Prepare un lugar de trabajo limpio y blando para evitar daños durante el montaje. Puede utilizar la caja y las protecciones internas como base. Comprueba también que tiene todas las piezas y partes antes de sumergirse en el montaje.

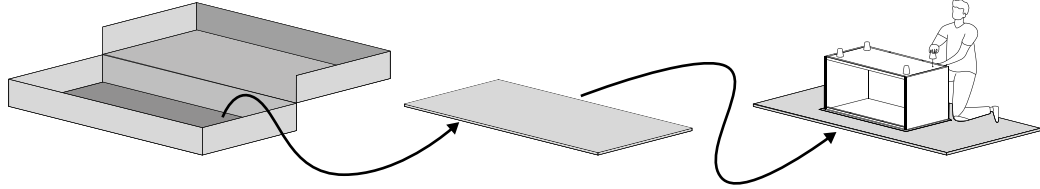

**Temps de montage
estimé**
**Tiempo estimado de
montaje**

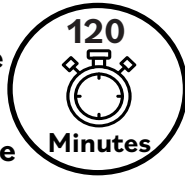

2 Personnes
2 Personas

Personnes recommandées pour le montage

Fais-en un effort d'équipe !
Appelle un ami pour un
assemblage plus rapide et plus
facile.

Personas recomendadas para el montaje

¡Hágalo en equipo!
Llame a un amigo para que el
montaje sea más rápido y sencillo.

Outils nécessaires

Munis-toi d'un tournevis cruciforme pour réaliser cet assemblage. Tu auras également besoin d'un marteau pour t'aider.

Herramientas requeridas

Tome un destornillador Phillips pour conquister este conjunto. También necesitaremos un martillo para ayudar.

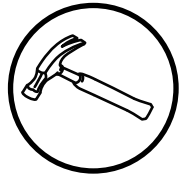
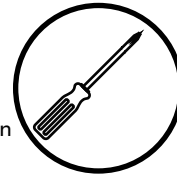

Utilise les outils électriques avec précaution

Ce meuble est réalisé en Bois Massif et Bois Composite, des matériaux souples. Si tu choisis d'utiliser des outils électriques, règle-les sur le mode le plus lent. Fais attention à toi ! Les outils électriques peuvent provoquer des fissures ou endommager les meubles, mais aussi les autres composants s'ils sont mal utilisés. Les dommages causés par un outil électrique ne sont pas couverts par la garantie Walker Edison.

Utilice las herramientas eléctricas con cuidado.

Este mueble está fabricado con madera maciza y madera compuesta, materiales blandos. Si decide utilizar herramientas eléctricas, ajústelas al ajuste más lento. Tenga cuidado. Las herramientas eléctricas pueden causar grietas o daños en el mueble, pero también en los herrajes si se utilizan mal. Los daños causados por una herramienta eléctrica no están cubiertos por la garantía de Walker Edison.

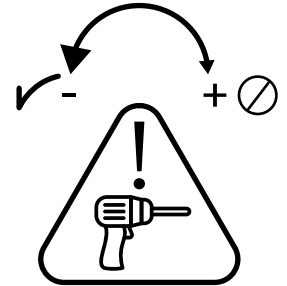

Attention avec la glissière

Tes meubles possèdent des glissières en bois très résistantes. De temps en temps, nous recommandons d'appliquer de la paraffine ou de la cire de bougie standard pour améliorer la glisse des curseurs.

Cuidado con las guías

Tus muebles cuentan con guías de madera de alta durabilidad. De vez en cuando, recomendamos la aplicación de parafina o cera estándar para mejorar el deslizamiento de los deslizadores.

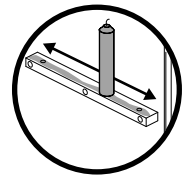

Scannez pour obtenir des conseils d'assemblage et de l'aide !
¡Escanee para obtener consejos de montaje y ayuda!

Liste de pièces / Lista de piezas

Nombre de pièces Description Quantité
Número de pieza Descripción Cantidad

1	Panneau Supérieur Panel Superior	1
2	Panneau Gauche Panel Izquierdo	1
3	Panneau Droit Panel Derecho	1
4	Panneau Inférieure Panel Inferior	1
5	Barre Avant Travesaño delantero	4
6	Panneau Central Panel Central	1
7	Panneau arrière Panel Trasero	2
8	Traverse Avant du Pied Travesaño Delantero del Pie	2
9	Traverse Latéral du Pied Travesaño del Lado del Pie	2
10	Pied Gauche Pie Izquierdo	2
11	Pied Droit Pie Derecho	2







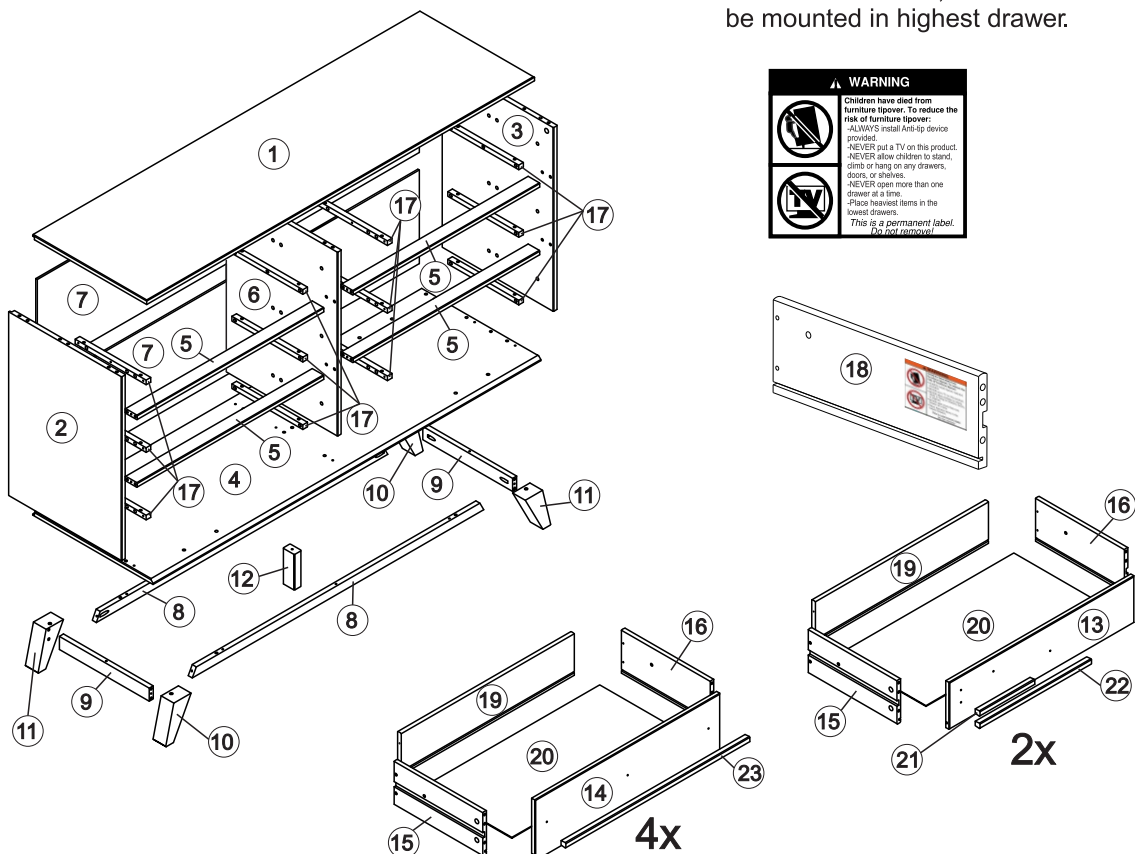



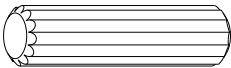
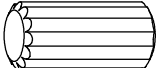

Nombre de pièces Description Quantité
Número de pieza Descripción Cantidad

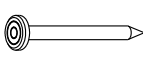
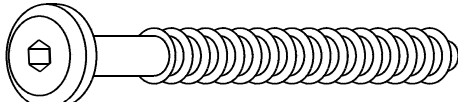
12	Pied Central Pie Central	1
13	Petit Façade du Tiroir Frente del Cajón Pequeño	2
14	Grand Façade du Tiroir Frente del Cajón Grande	4
15	Côté Gauche du Tiroir Lado Izquierdo del Cajón	6
16	Côté Droit du Tiroir Lado Derecho del Cajón	5
17	Glissières en Bois Correderas de madera	12
18	Côté Droit du Tiroir avec avertissement Lado Derecho del Cajón con advertencia	1
19	Arrière du Tiroir Parte Trasera del Cajón	6
20	Fond du Tiroir Fondo del Cajón	6
21	Petit Poignée du Tiroir Manija Pequeña del Cajón	2
22	Poignée du Tiroir Manija del Cajón	2
23	Grand Poignée du Tiroir Manija Grande del Cajón	4

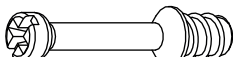
The side drawer with
WARNING LABEL, should
be mounted in highest drawer.

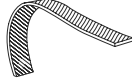

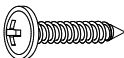
Liste de composants / Lista de hardware

	Parte Parte	Taille Tamaño	Nom Nombre	Quantité Cantidad
A		Ø8*30mm	Cheville en bois Espiga de madera	72
B		Ø10*20mm	Cheville en bois Espiga de madera	36
C		Ø4,0*25mm	Vis Tornillo	56
D		Ø3,5*30mm	Vis Tornillo	40
E		Ø4,0*40mm	Vis Tornillo	17
F		Ø10*10mm	Clou Clavo	36
G		Ø7,0*60mm	Vis Tornillo	05
H		4mm	Clé Allen Llave Allen	01
I		Ø8*40mm	Cheville en bois Espiga de madera	12
J		ø15*30mm	Goujon de Assemblage Conector	33
K		ø15*10mm	Boitier de Assemblage Traba del Conector	33
L			Courroie d' Ancrage Correa de Anclaje	01
M			Rondelle Arandela	02
N		Ø6*35mm	Cheville en Plastique Taco Plástico	01
O		Ø4*16mm	Vis Tornillo	01
P		Ø4,0*40mm	Vis Tornillo	01
Q		1483mm	Profil H Perfil H	01

Les quantités de composants indiquées ci-dessus sont nécessaires pour un assemblage correct.

Des pièces supplémentaires peuvent être incluses.

Las cantidades de tornillería indicadas anteriormente son necesarias para un montaje correcto.

Se pueden incluir piezas de ferretería adicionales.

Étape / Paso 1

(FR)
Commence! Insère las Chevilles (B) dans le Glissières en Bois
(17)
(ES)
¡Manos a la obra! Inserta las Espigas (B) en las Correderas de Madera (17)

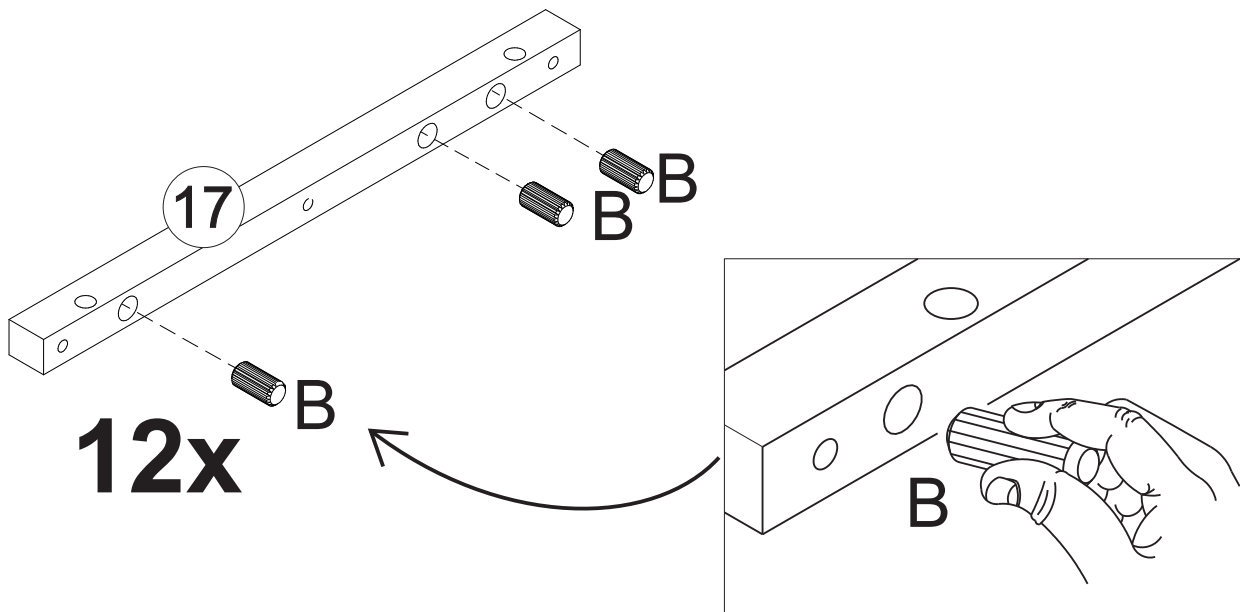
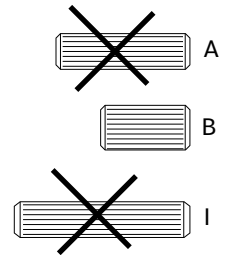
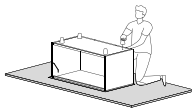

Tip

Cheville en bois

Les chevilles sont essentielles lors de l'assemblage de meubles pour créer des connexions solides et précises. Elles garantissent l'intégrité structurelle, empêchent les déplacements et simplifient l'alignement, ce qui permet d'obtenir des meubles plus résistants et plus durables. suis ces étapes :

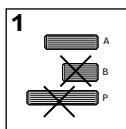

1: Sélectionne la taille de cheville appropriée en fonction de l'étape.
1: Seleccione el tamaño de espiga adecuado según el paso.

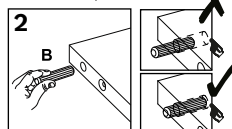

2: Insère dans le trou indiqué et appuie fermement pour assurer un positionnement correct.
2: Insértela en el orificio indicado y presione firmemente para asegurar su correcta colocación.

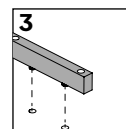

3: Alinee la cheville avec la pièce correspondante et enfonce-la jusqu'à ce qu'elle soit ferme.
3: Alinee el pasador con la pieza correspondiente y presiónelo hasta que encaje.

Espiga de madera

Las espigas son esenciales en el montaje de muebles para crear uniones fuertes y precisas.

Garantizan la integridad estructural, evitan el desplazamiento y simplifican la alineación, lo que se traduce en muebles más resistentes y duraderos.

Sigue estos pasos:

Étape / Paso 2

(FR)

Aussi insère Chevilles (A) dans le Panneau Gauche (2), Panneau Droit (3), Traverse Avant (5), Panneau Central (6), Traverse Avant du Pied (8), Traverse Latéral du Pied (9), Côté Gauche du Tiroir (15), Côté Droit du Tiroir (16) and Côté Droit du Tiroir avec Avertissement (18).

(ES)

También inserta las Espigas (A) em el Panel Izquierdo (2), Panel Derecho (3), Travesaño Delantero (5), Panel Central (6), Travesaño Delantero del Pie (8), Travesaño del Lado del Pie (9), Lado Izquierdo del Cajón (15), Lado Derecho del Cajón (16) y Lado Derecho del Cajón com Advertencia (18).

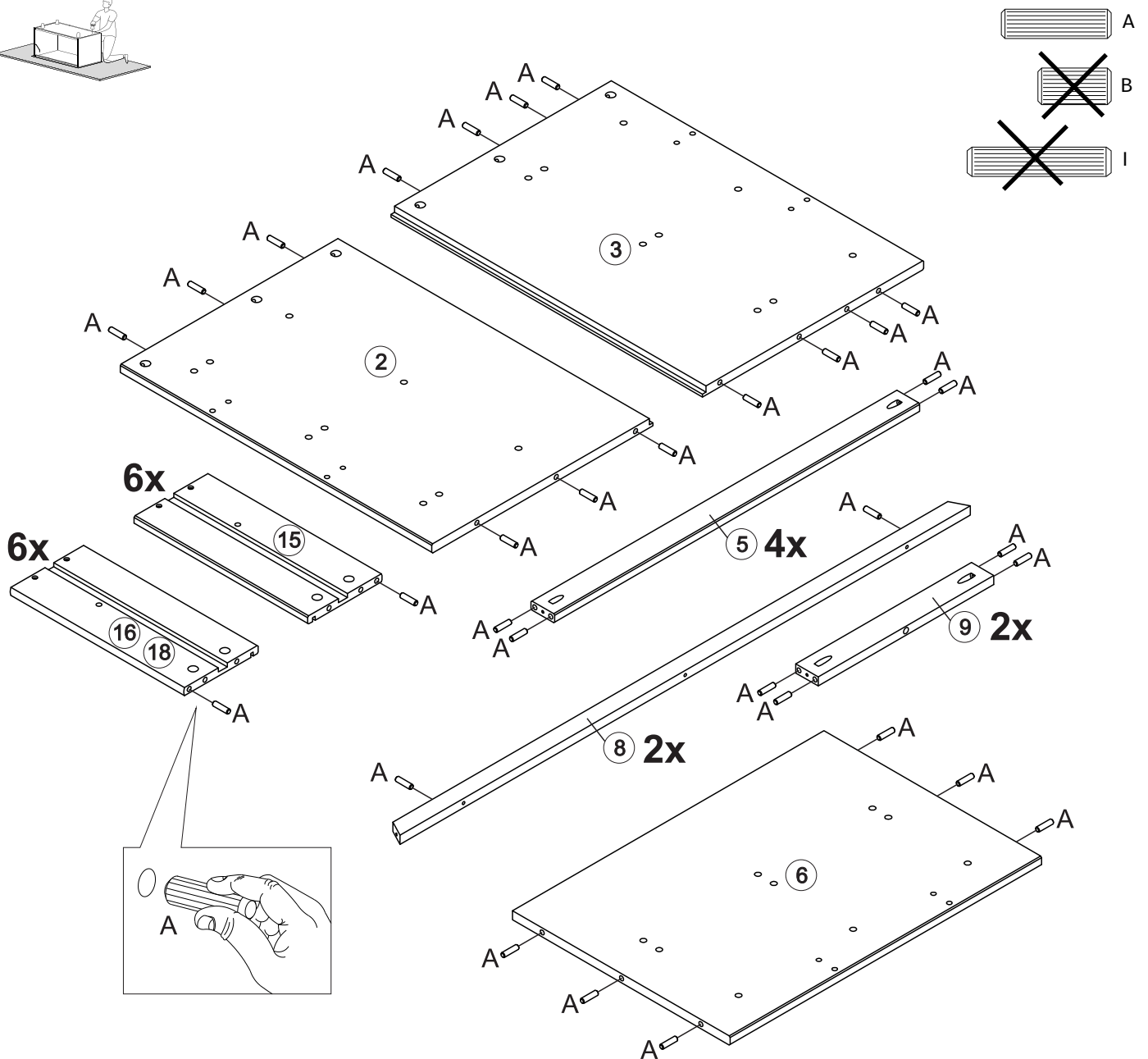

Pour que ton produit conserve son meilleur aspect et sans rayures, essaie de le monter sur une surface souple telle qu'un tapis ou une couverture. Cela permet d'éviter les rayures accidentelles et de garder tes meubles en bon état!

Para mantener su producto con el mejor aspecto y sin arañazos, prueba a montarlo sobre una superficie blanda, como una alfombra o una manta. Así evitará arañazos accidentales y mantendrá sus muebles en perfecto estado.



Étape / Paso 3

(FR)

Attacher le Goujon de Assemblage (J) dans le Panneau Supérieur (1), Petit Façade du tiroir (13) et Grand Façade du tiroir (14)

(ES)

Fije el Conector (J) em el Panel Superior (1), Frente del Cajón Pequeño (13) y Frente del Cajón Grande (14).

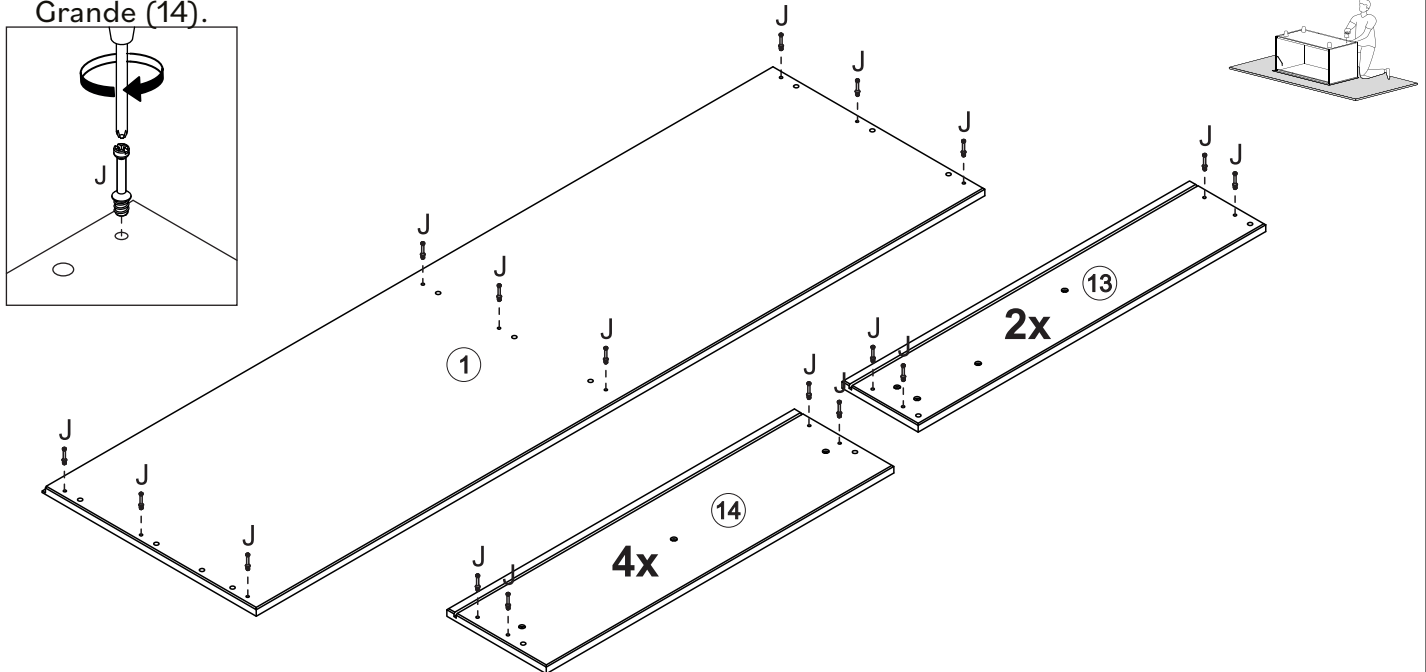

Étape / Paso 4

(FR)

Fixez le Glissières en Bois (17) au Panneau Gauche (2) et Panneau Droit (3) utilisant Vis (C) et un tournevis Phillips.

(ES)

Fije las Correderas de Madera (17) en el Panel Izquierdo (2) y Panel derecho (3) utilizando Tornillo (C) y un destornillador Phillips.

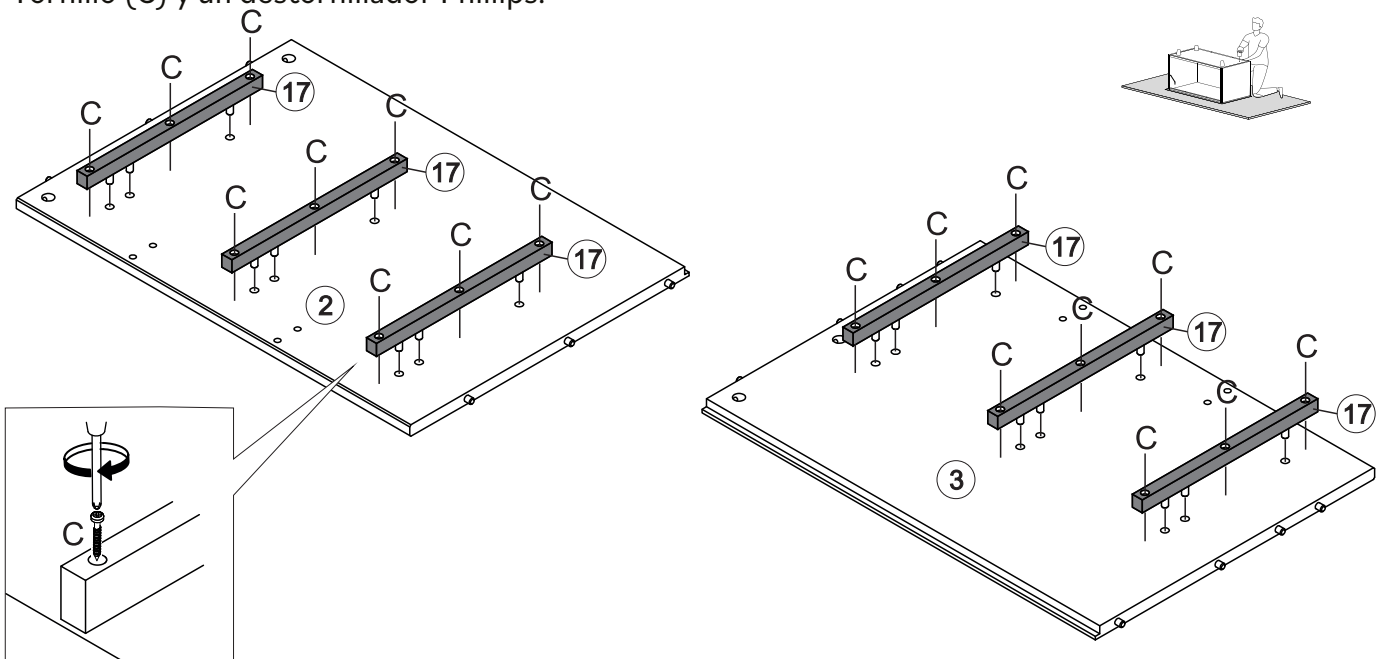

Étape / Paso 5

(FR)

Fixez le Glissières en Bois (17) des deux côtés del Panneau Central (6) à l'aide de la Vis (C) et d'un tournevis Phillips.

(ES)

También fije las Correderas de Madera (17) en los dos lados del Panel Central (6) utilizando el Tornillo (C) y un destornillador Phillips.

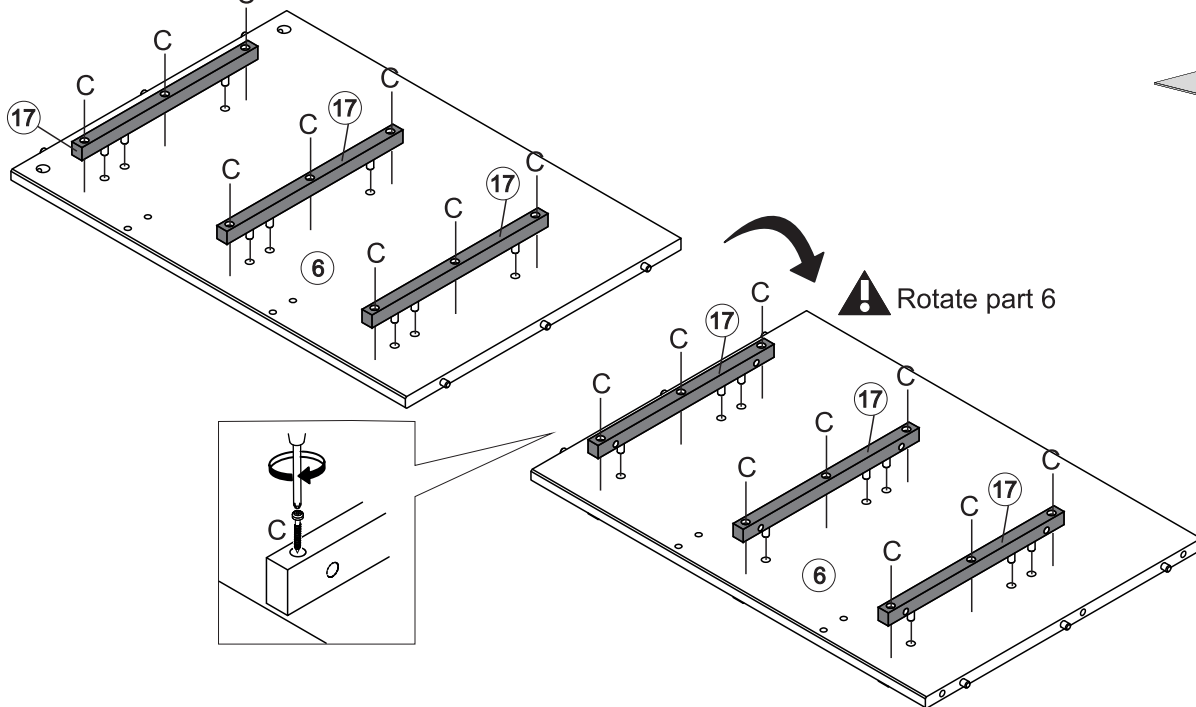

Étape / Paso 6

(FR)

Fixez le Traverse Avant (5) au Panneau Gauche (2), au Panneau Droit (3) et à le Panneau Central (6), à l'aide de Vis (D) et d'un tournevis Phillips.

(ES)

Monta el Travesaño Delantero (5) al Panel Izquierdo (2), Panel Derecho (3) y al Panel Central (6), con ayuda del Tornillo (D) y um destornillador Phillips.

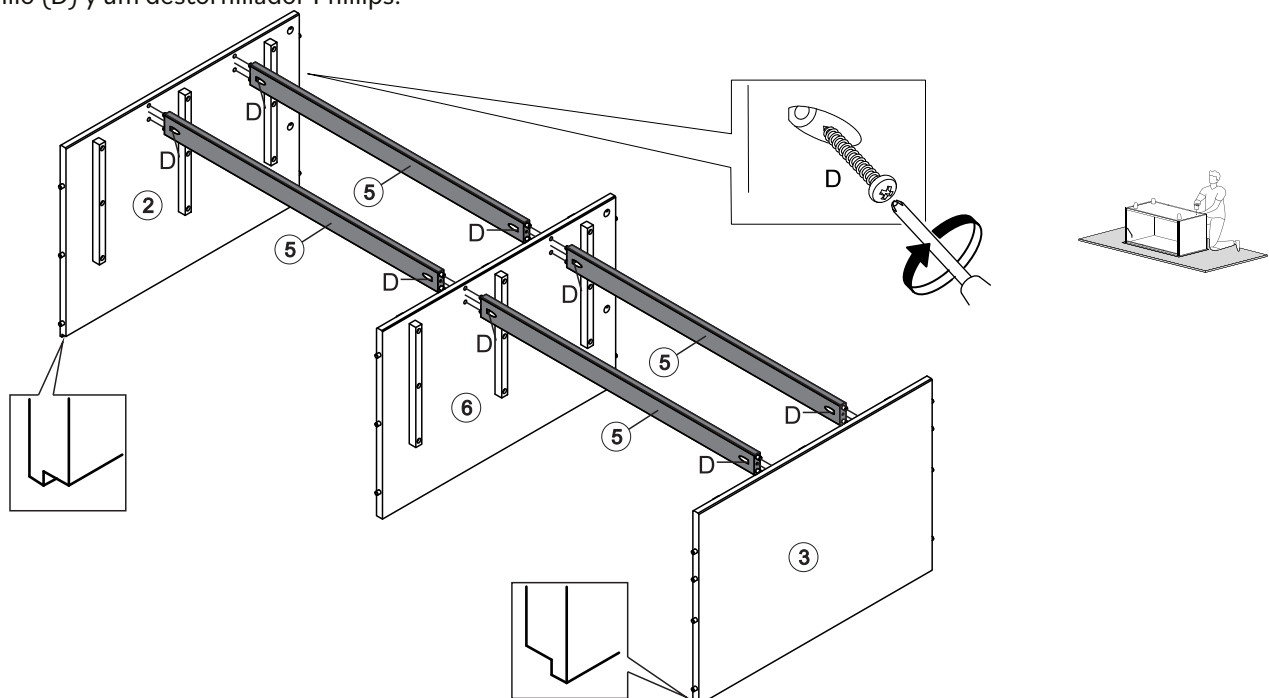

Étape / Paso 7

(FR)

Monte le Traverse Latéral du Pied (9) au Pied Gauche (10) et Pied Droit (11) à l'aide de Vis (D) et d'un tournevis Phillips

(ES)

Fije la Traverse Latéral du Pied (9) al Pie Izquierdo (10) y Pie Derecho (11) utilizando el Tornillo (D) y um destornillador Phillips.

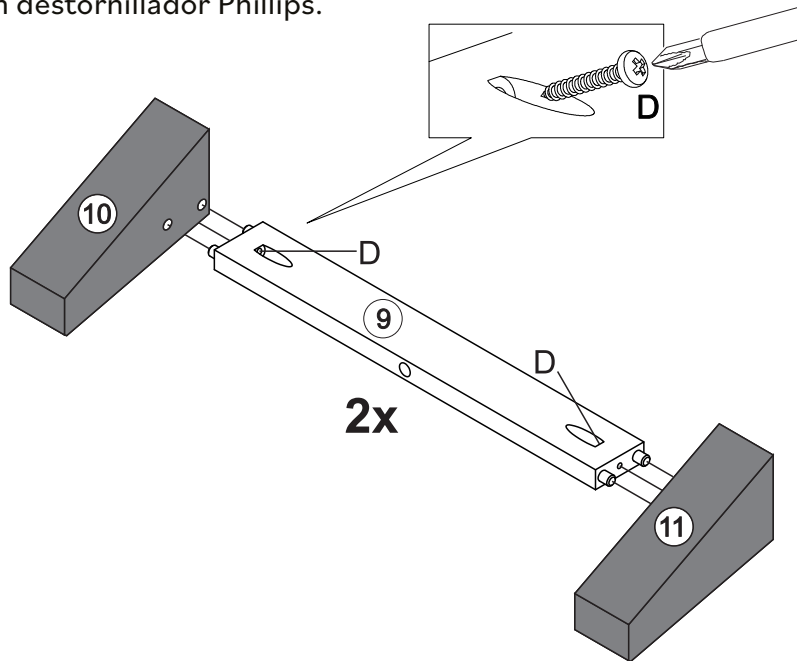

Étape / Paso 8

(FR)

Attacher Traverse Avant du Pied (8) au Panneau Inférieur (4) utilisant Vis (E) et un tournevis Phillips.

(ES)

Fije el Travesaño Delantero del Pie (8) al Panel Inferior (4) usando el Tornillo (E) y un destornillador Phillips.

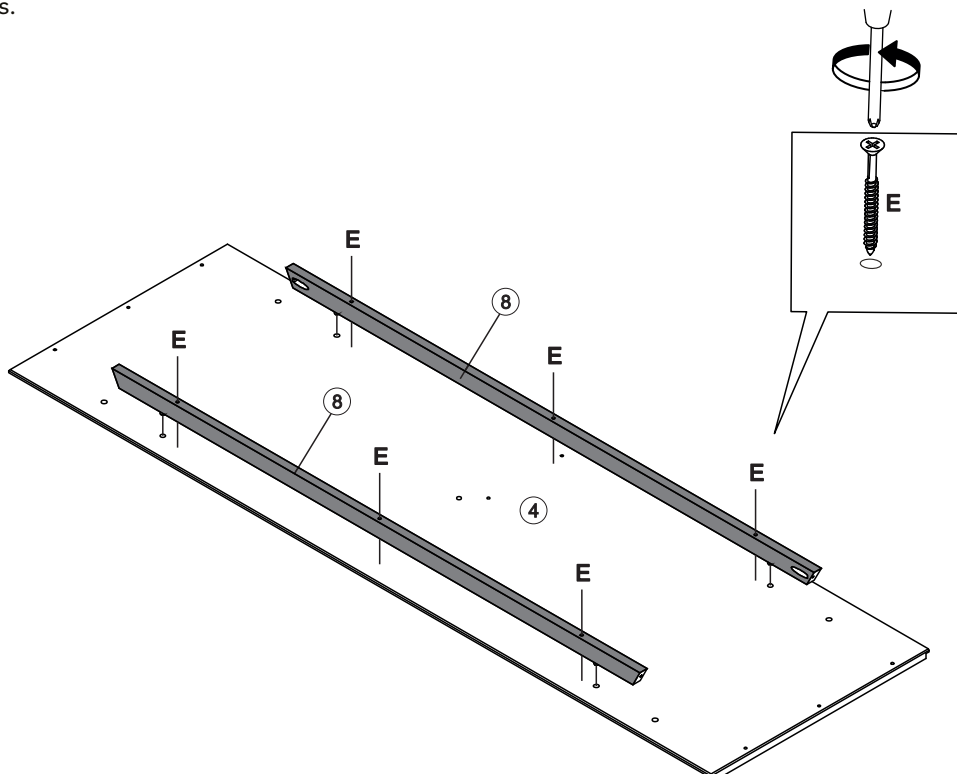

Étape / Paso 9

(FR) Fixez les pieds que vous avez assemblés précédemment et le Pied central (12) à l'Panneau Inférieur (4) à l'aide de la Vis (G) et de la clé Allen (H). Laissez les vis (G) un peu desserrées pour les étapes suivantes

(ES) Asegure los Pies que ensambló anteriormente y el Pie Central (12) al Panel Inferior (4) usando el Tornillo (G) y la Llave Allen (H). Deje los Tornillos (G) un poco flojos para pasos futuros.

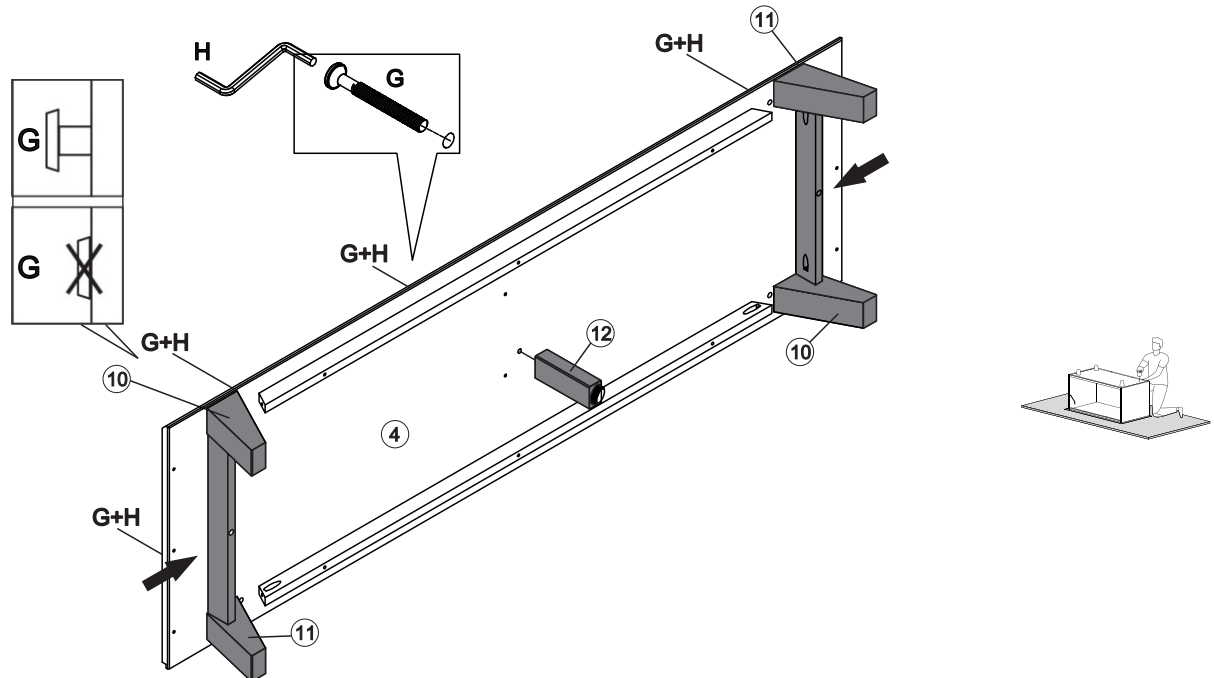

Étape / Paso 10

(FR) Fixez le Traverse Avant du Pied (8) au Pied Gauche (10) et au Pied Droit (11) à l'aide de la Vis (D) et d'un tournevis Phillips.

(ES) Fije en Travesaño Delantero del Pie (8) al Panel Izquierdo (10) y Panel Derecho (11) con el Tornillo (D) y un destornillador Phillips.

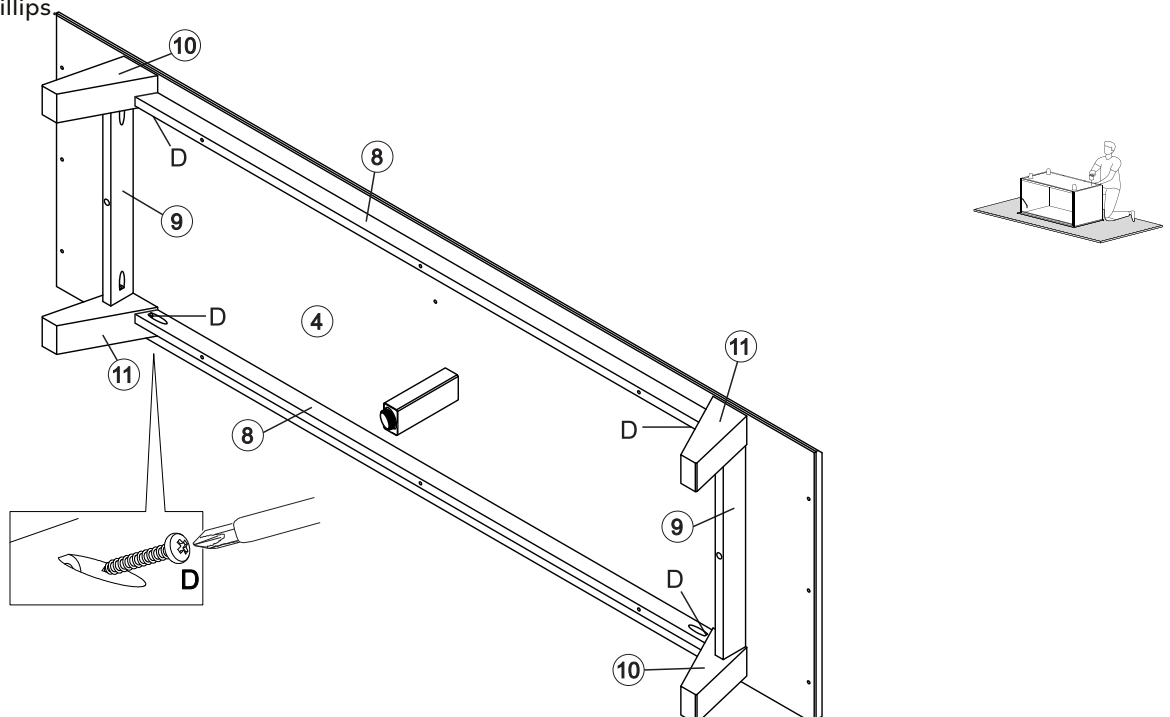

Étape / Paso 11

(FR) Attacher Panneau Inférieur (4) au Panneau Gauche (2), Panneau Droit (3) et Panneau Central (6) à l'aide de la Vis (E) et d'un tournevis Phillips.

(ES) Monte el Panel Inferior al Panel Izquierdo (2), Panel Derecho (3) y Panel Central (6) utilizando el Tornillo (E) i un destornillador Phillips.

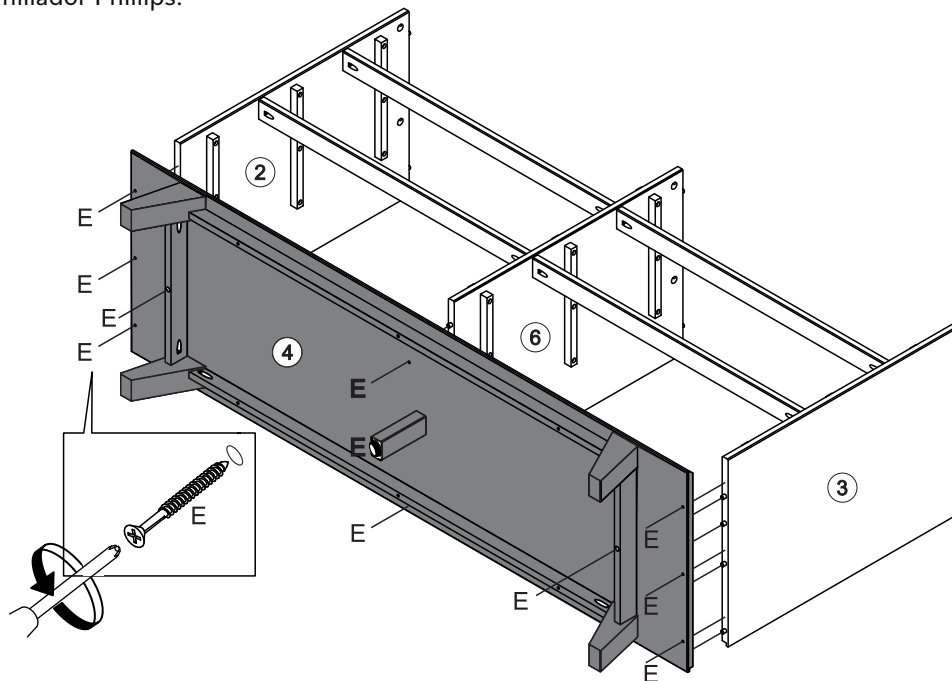

Étape / Paso 12

(FR) Monte le Panneau Supérieur (1) au Panneau Gauche (2), Panneau Droit (3) et Panneau Central (6) à l'aide de l' Boitier de Assemblage (K) et d'un tournevis Phillips.

(ES) Asegure el Panel Superior (1) al Panel Izquierdo (2), Panel Derecho (3) y a el Panel Central (6) usando la Traba del Conector (K) y un destornillador Phillips.

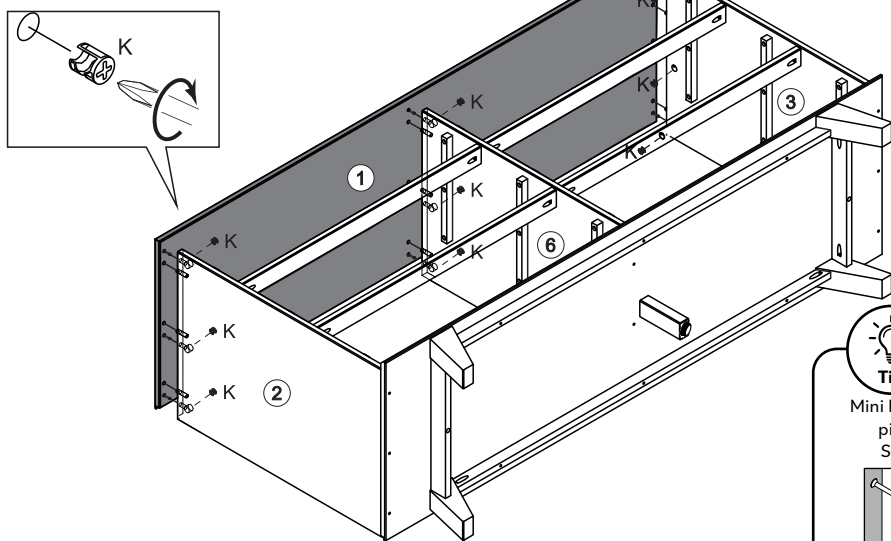

Tip
Mini Fix permet de joindre deux pièces en toute sécurité. Suis ces étapes simples.



1: Insère le Mini Fix dans les orifices du côté plat. Ne serrez pas trop!

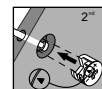

2: Joins les pièces en bois. Les vis Mini Fix entrent dans les orifices qui ont des trous sur les côtés, tu dois pouvoir voir les vis Mini Fix à travers ceux-ci. Après avoir installé les pièces, insère le tambour Mini Fix dans les orifices latéraux.

2: Une las piezas de madera. Los tornillos Mini Fix entran en las piezas que tienen orificios en los lados, por lo que deberías poder ver los tornillos Mini Fix a través de ellos. Después de encajar las piezas, inserta el tambor del tornillo Mini Fix en los orificios laterales.



Los tornillos Mini Fix ayudan a unir de forma segura dos piezas. Sigue estas fáciles etapas.

3: Sur la partie arrière du tambour, il aura la forme d'un « C ». Insère le tambour de manière à ce que l'ouverture « C » s'embote à la vis Mini Fix. Serre-la avec le tournevis.

3: La parte posterior del tambor tendrá la forma de « C ». Inserta el tambor de modo que la abertura de la « C » encaje en el tornillo Mini Fix. Apriétalo con un destornillador.

Étape / Paso 13

(FR)

Insère les Clavillas (A) dans le premier trou du Glissières en Bois (17)

(ES)

Inserte la Espiga (A) en el primer agujero de las Correderas de madera (17).

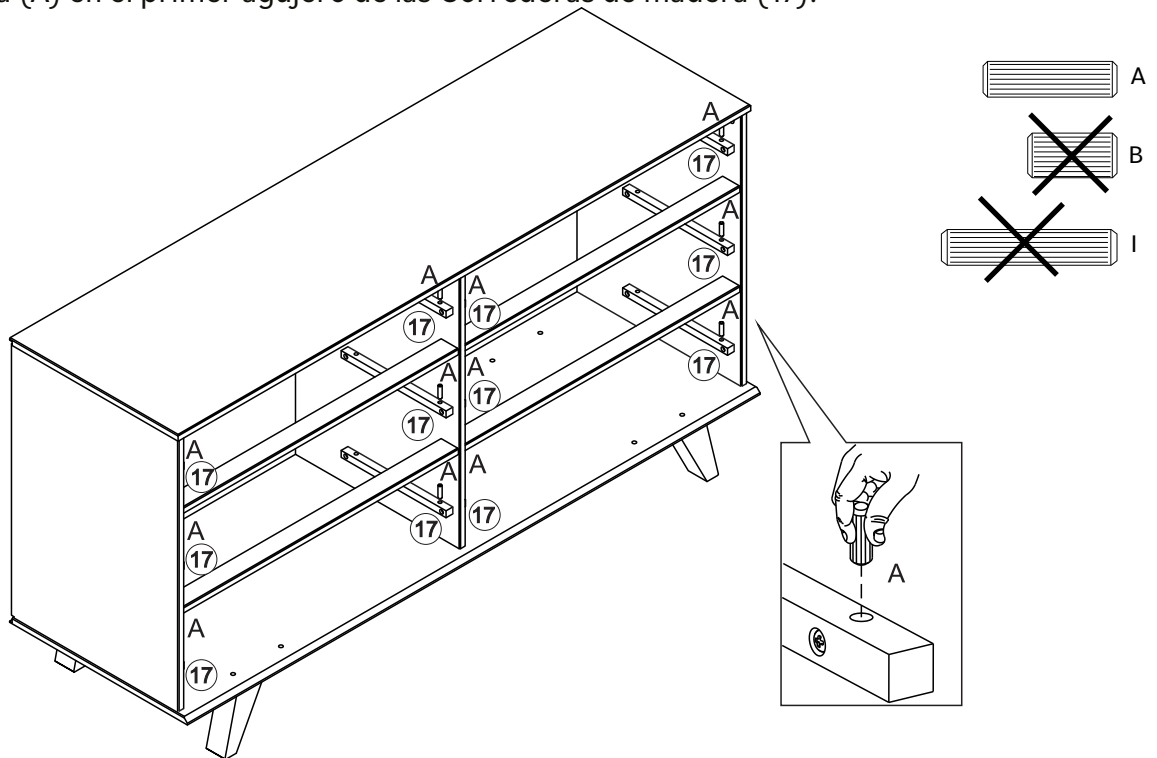

Étape / Paso 14

(FR)

Fixes le Panneau Arrière (7) à l'aide du Profil H (Q) à votre commode avec des Clous (F) et un marteau.

(ES)

Asegure el Panel Trasero (7) usando el Perfil H (Q) a su cómoda con Clavos (F) y un martillo

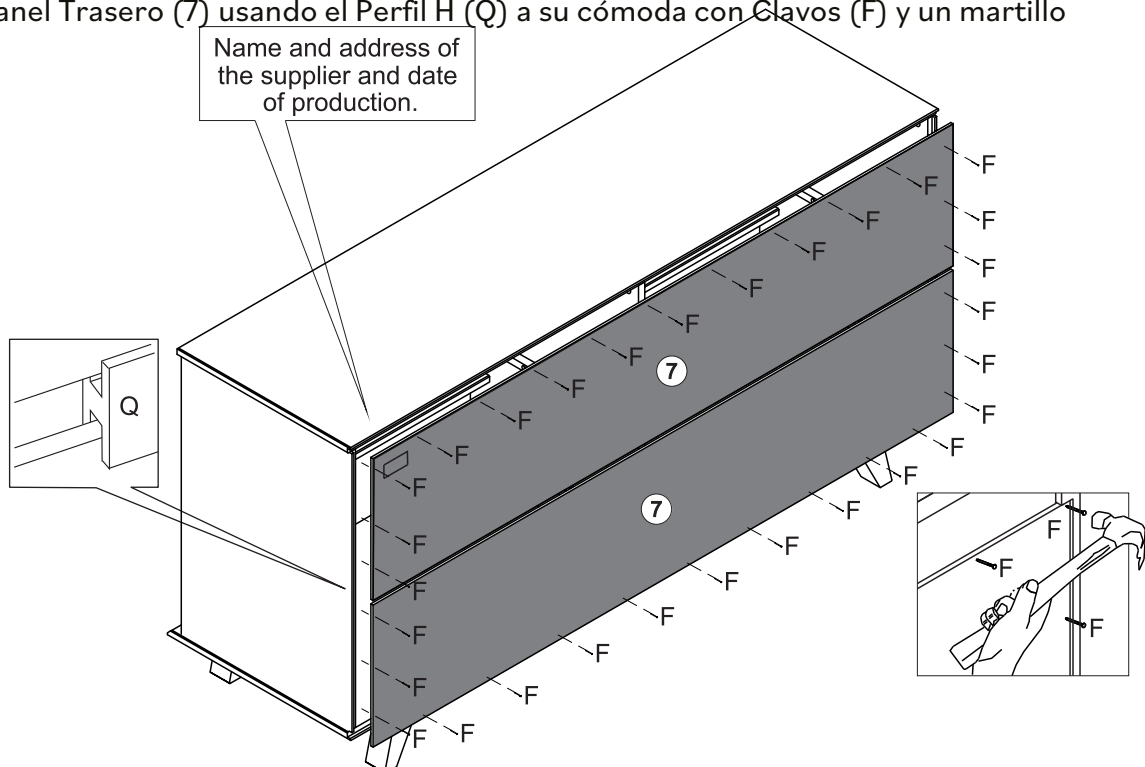

Étape / Paso 15

(FR)

Fixez aussi le Panneau Arrière (7) au Panneau Central (6) utilisant Clous (F) et un marteau

(ES)

Asegure el Panel Trasero (7) a la Panel Central (6) usando Clavos (F) y un martillo

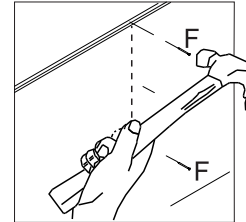
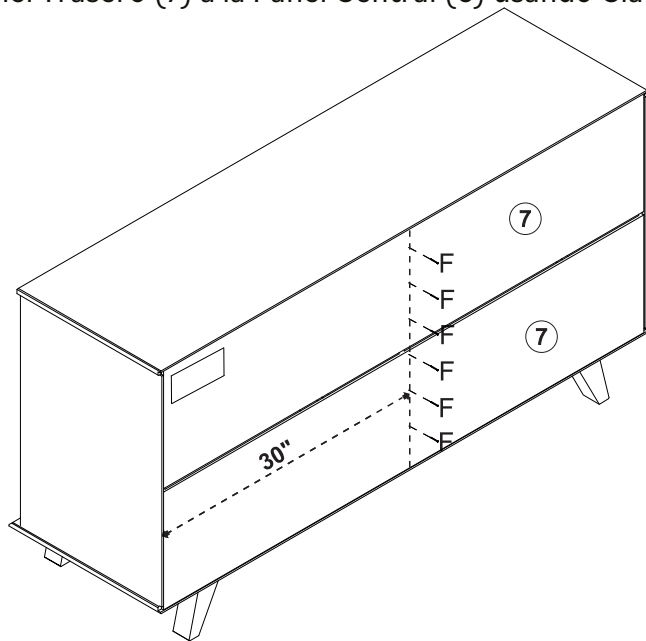

Étape / Paso 16

(FR)

Assemblons les tiroirs maintenant ! Fixez la Petite Poignée de Tiroir (21) et la Poignée de Tiroir (22) à la Petite Façade de Tiroir (13) et la Grande Poignée de Tiroir (23) à la Grande Façade de Tiroir (14) à l'aide des Vis (C) et d'un tournevis Phillips.

(ES)

Conecte la Manija del Cajón Pequeño (21) y la Manija del Cajón (22) al Frente del Cajón Pequeño (13) y la Manija del Cajón Grande (23) al Frente del Cajón Grande (14) usando Tornillos (C) y un destornillador Phillips.

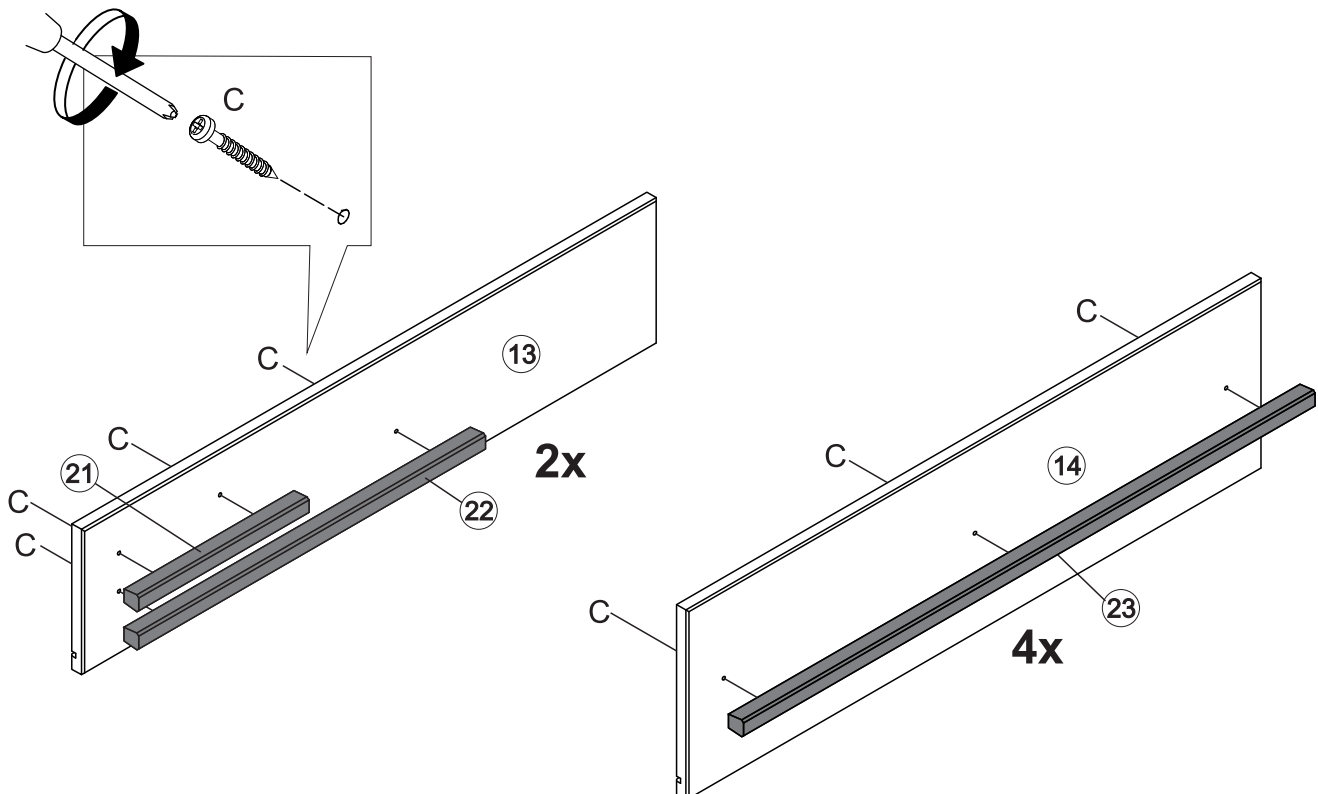

Étape / Paso 17

(FR) Installez les Goujons de Assemblage (J) sur la Petite Façade du Tiroir (13) sur le Côté Gauche du Tiroir (15), le Côté Droit du Tiroir (16) et le Côté Droit du Tiroir avec Avertissement (18) et fixez-les avec le Boitier de Assemblage (K) et un tournevis Phillips.

(ES) Coloque los Conectores (J) en el Frente del Cajón Pequeño (13) en el Lado Izquierdo del Cajón (15), en el Lado Derecho del Cajón (16) y en el Lado Derecho del Cajón con Advertencia (18) y fíjelos con la Traba del Conector (K) y un destornillador Phillips.

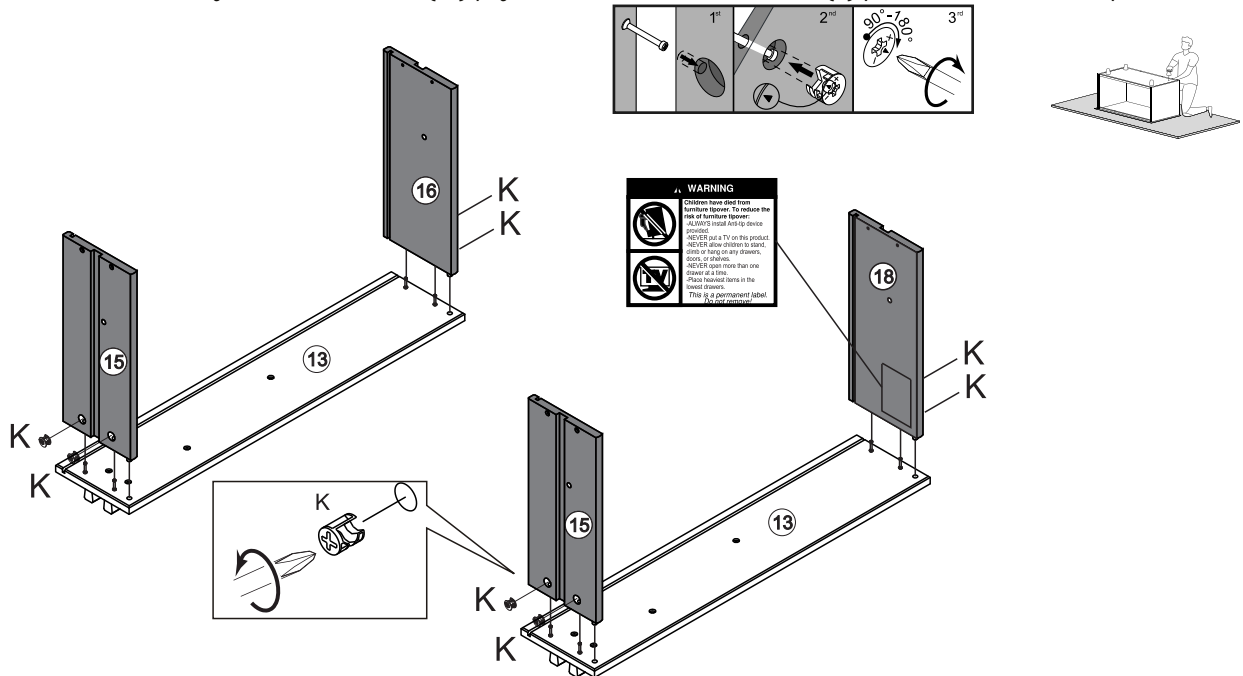

Étape / Paso 18

(FR) Faites glisser le Fond du Tiroir (20) sur les rainures des Côtés Droit et Gauche du Tiroir (15,16/18) en s'adaptant à la Façade du Tiroir (13). Fixez l'Arrière du Tiroir (19) aux Côtés Droit et Gauche du Tiroir (15,16/18) à l'aide des Vis (D) et d'un tournevis Phillips.

(ES) Deslice la Parte Inferior del Cajón (20) en las ranuras de los Lados Derecho e Izquierdo del Cajón (15,16/18) que encajan en el Frente del Cajón (13). Fije la Parte Trasera del Cajón (19) al Lado Derecho e Izquierdo del Cajón (15,16/18) usando Tornillos (D) y un destornillador Phillips.

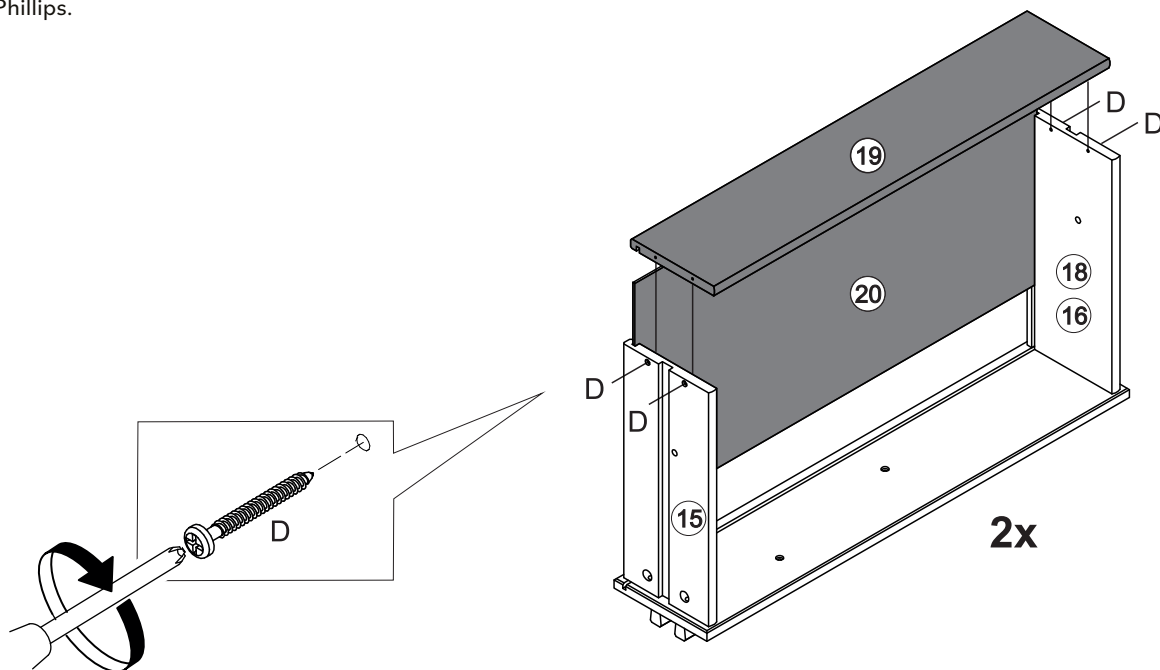

Étape / Paso 19

(FR)
Installez les Goujons de Assemblage (J) sur la Grande Façade du Tiroir (14) sur le Côté Gauche du Tiroir (15) et sur le Côté Droit du Tiroir (16) et fixez-les avec le Boitier de Assemblage (K) et un tournevis Phillips.

(ES)
Coloque los Conectores (J) en el Frente del Cajón Grande (14), Lado Izquierdo del Cajón (15), Lado Derecho del Cajón (16) y fíjelos con la Traba del Conector (K) y un destornillador Phillips.

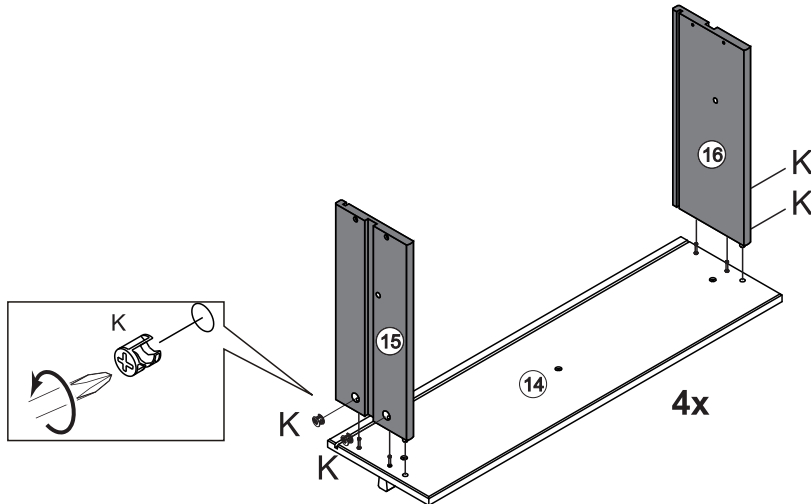
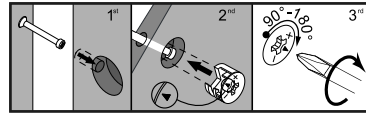

Étape / Paso 20

(FR)
Faites glisser le Fond du Tiroir (20) sur les rainures des Côtés Droit et Gauche du Tiroir (15,16) en s'ajustant sur Façade de Tiroir (14). Fixez le Arrière du Tiroir (19) aux Côtés Droit et Gauche du Tiroir (15,16) à l'aide Vis (D) et un tournevis Phillips.

(ES)
Deslice la Parte Inferior del Cajón (20) en las ranuras de los Lados Derecho e Izquierdo del Cajón (15,16) hasta encajar en el Frente de Cajón (14). Conecte la Parte Trasera del Cajón (19) al Lado Derecho e Izquierdo del Cajón (15,16) usando Tornillos (D) y un destornillador Phillips.

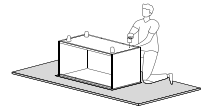
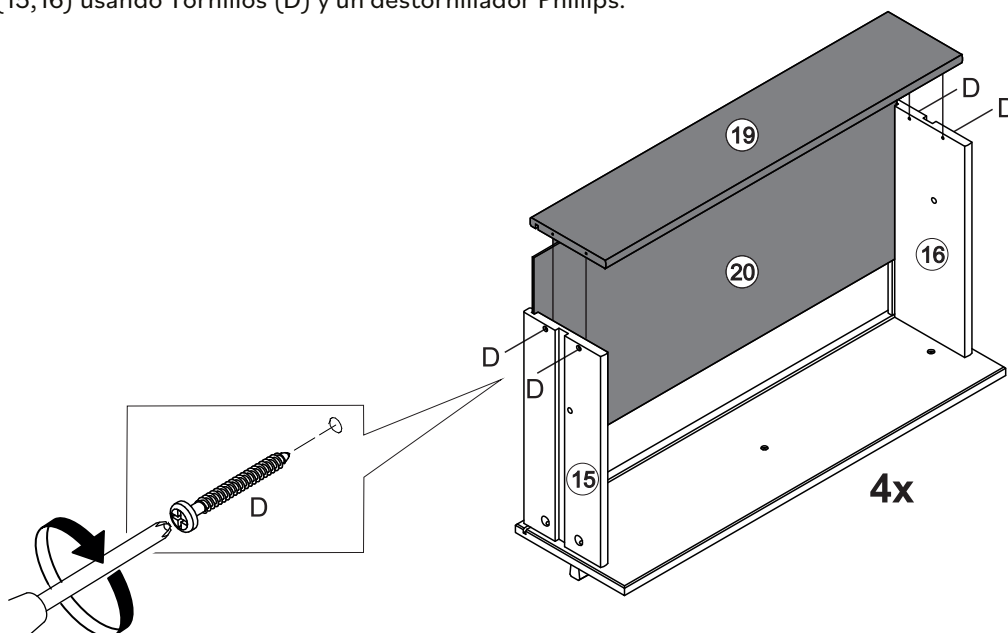

Étape / Paso 21

(FR)

Insérez la Cheville (I) à l'intérieur de tous les tiroirs, avec le tiroir à l'intérieur de l'unité après avoir passé la cheville qui se trouve dans la Glissière du Tiroir (17). La cheville n'est pas à fleur du panneau, elle se trouve un peu à l'intérieur du tiroir pour vous aider lorsque vous devez retirer la cheville de verrouillage pour retirer le tiroir.

(ES)

Inserte la Espiga (I) en el interior de todos los cajones, con el cajón dentro de la unidad después de haber pasado la espiga que se encuentra en Corredera de Madera (17). La espiga no está al ras con el panel, está un poco dentro del cajón para ayudar cuando necesite quitar la espiga de bloqueo para quitar el cajón.

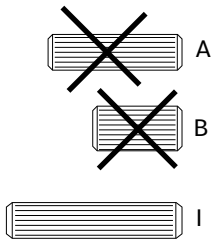

The assembled drawer with this warning must be placed on top of the unit.

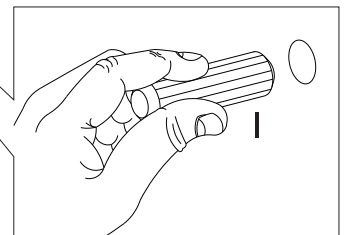
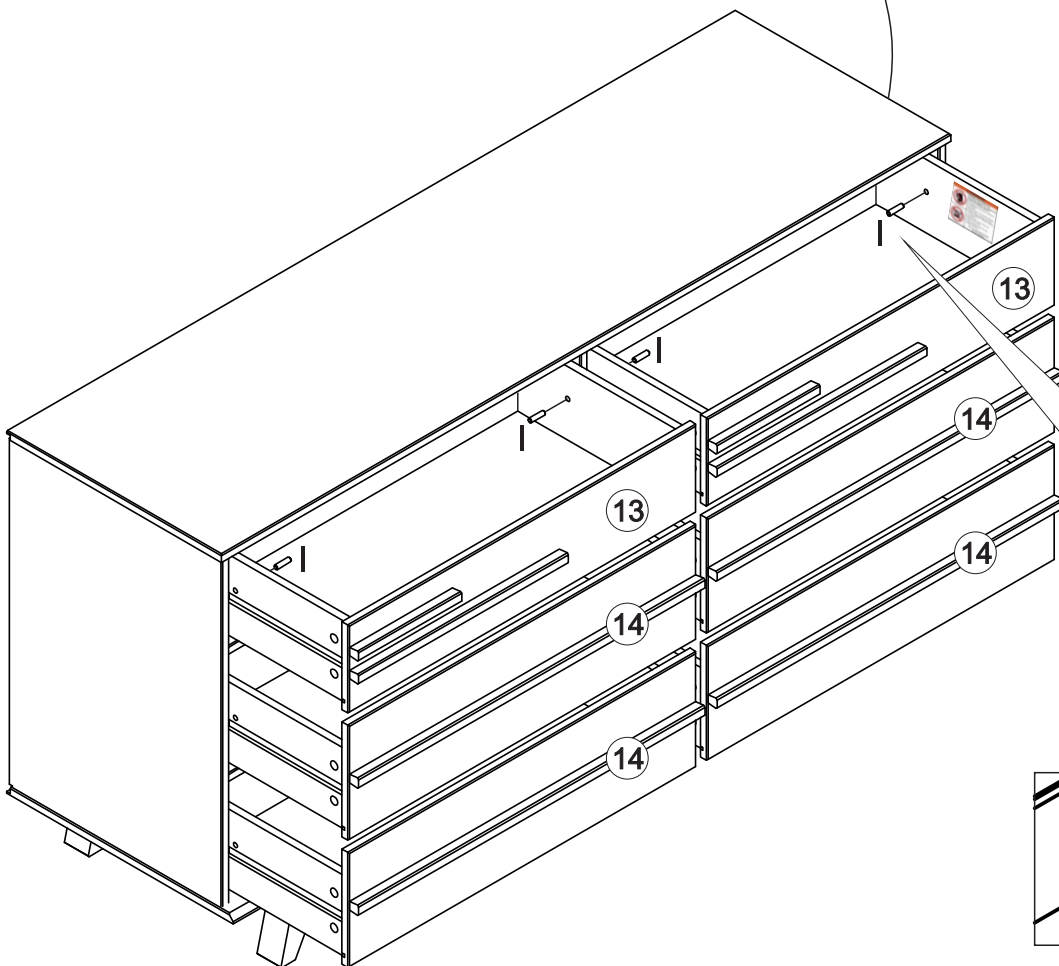

Étape / Paso 22

(FR)

Pour finir, fixons votre commode au mur ! Fixez l'ancrage mural (L) à votre commode avec une rondelle (M) et une vis (O) à l'aide d'un tournevis Phillips.

(ES)

Para terminar, ¡aseguremos su cómoda a la pared! Fije el anclaje de pared (L) a su cómoda con una arandela (M) y un tornillo (O) usando un destornillador Phillips.

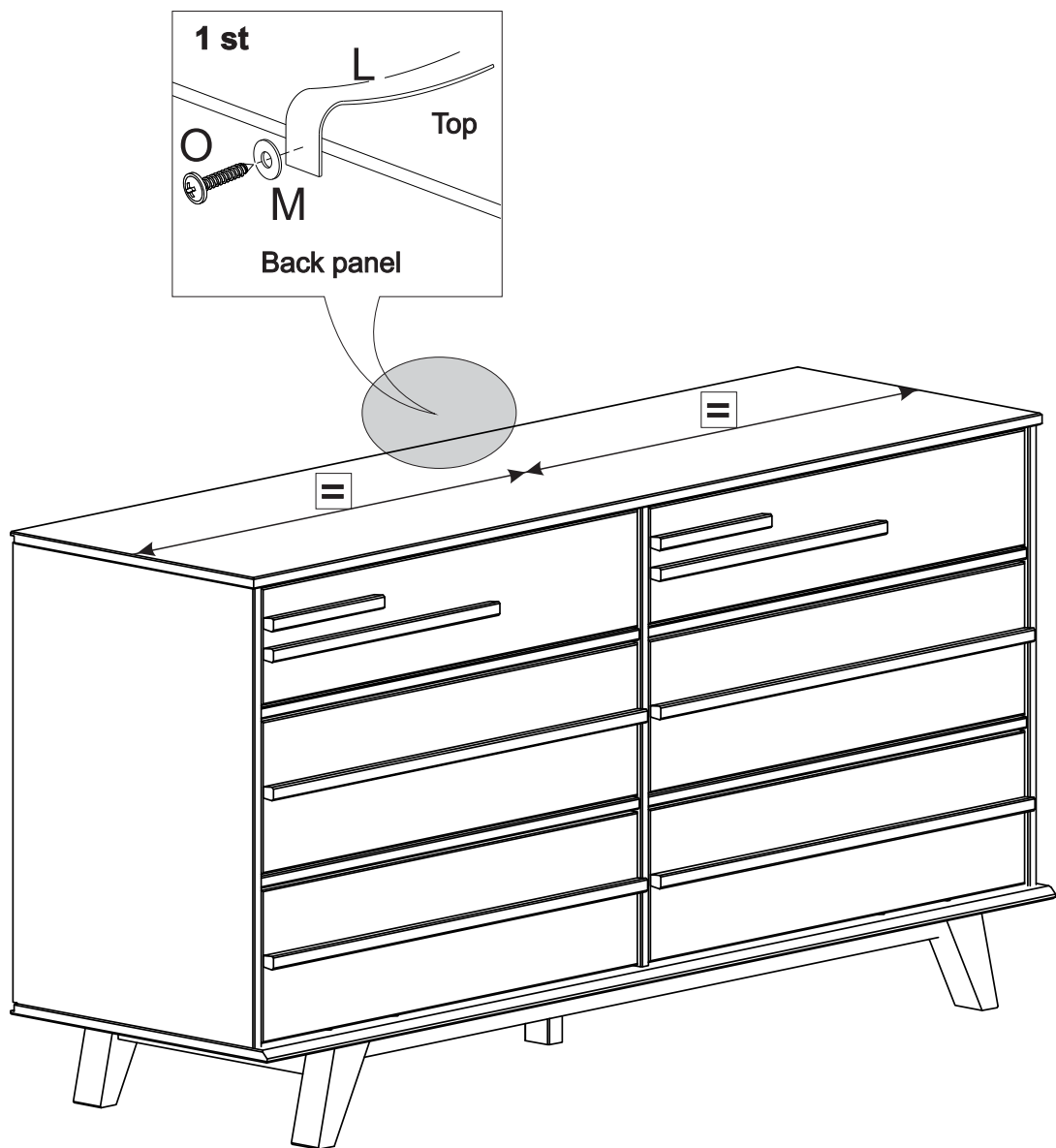

Étape / Paso 23

(FR)

Insère la cheville en plastique (N) dans le trou du mur. Ensuite fixe le ruban (L) au mur à l'aide de la rondelle (M) et des vis (P).

(ESP)

Coloca el tapón de plástico (N) en el orificio de la pared. Luego, fija el cordón (L) a la pared usando la arandela (M) y el tornillo (P).

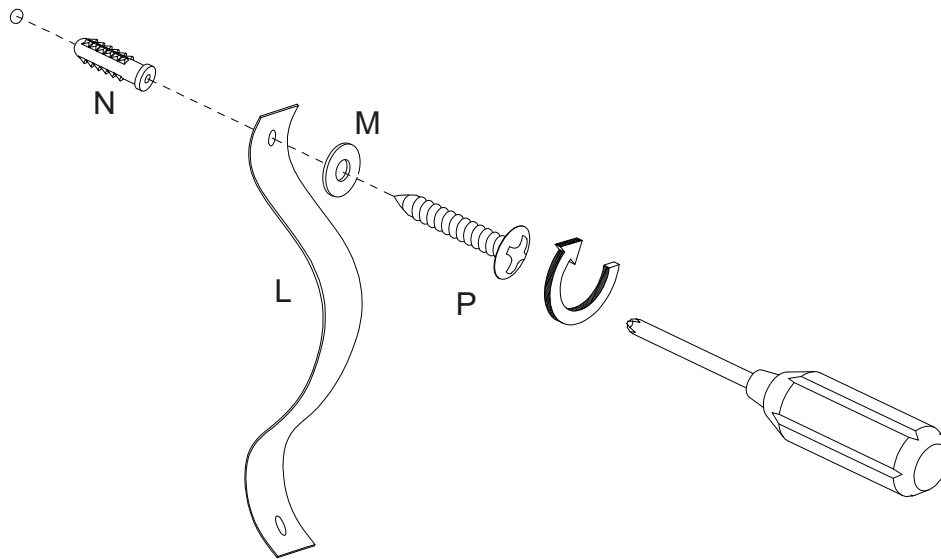
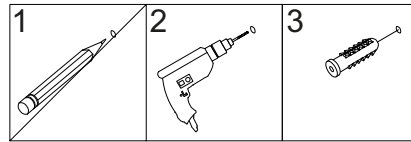

Avertissement

Des blessures graves, voire mortelles, peuvent survenir en cas de renversement de meubles. Pour éviter que le meuble ne bascule, nous recommandons de le fixer définitivement au mur. L'ancrage mural et les autres composants sont inclus dans ce produit. Assure-toi que les composants sont adaptés à tes murs avant l'installation, car différents matériaux de mur peuvent nécessiter différents types d'ancrages.

Le nom et l'adresse du fabricant responsable des composants anti-basculer ainsi que la date de production se trouvent sur l'étiquette au dos du meuble.

Advertencia

Pueden ocurrir lesiones graves o fatales debido a la caída de muebles. Para evitar que los muebles se caigan, recomendamos que se fijen permanentemente a la pared. El anclaje de pared y los herrajes están incluidos en este producto. Asegúrate de que los herrajes sean adecuados para tus paredes antes de la instalación, ya que diferentes materiales de pared pueden requerir diferentes tipos de anclajes.

El nombre y la dirección del fabricante responsable de los herrajes antivuelco y la fecha de producción se pueden encontrar en la etiqueta de la parte trasera de los muebles.

Tu as réussi ! Profite de ton nouveau

Commode!

¡Lo ha conseguido! ¡Disfrute de su nueva

Cómoda!

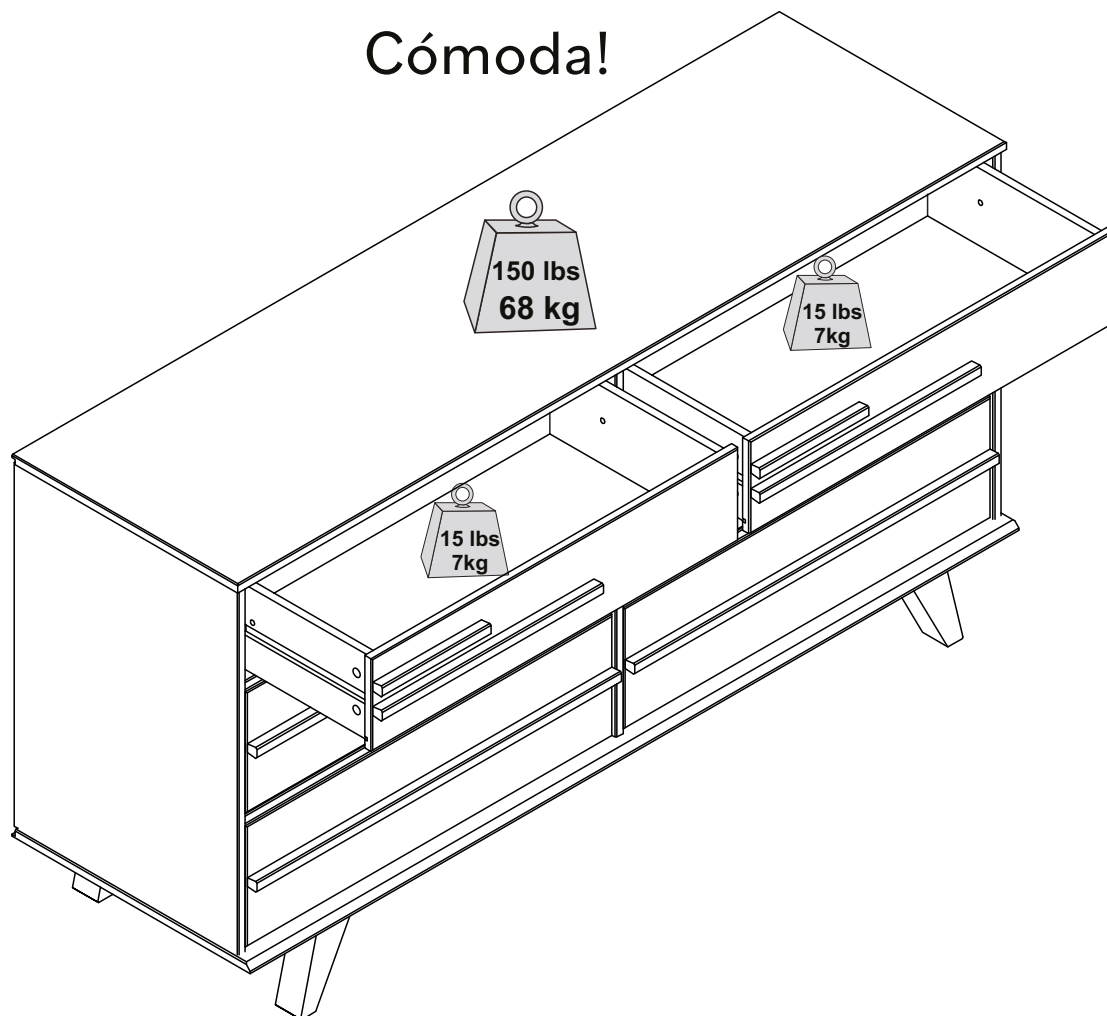

Bravo pour ton nouveau meuble !

Nous aimerions t'en entendre parler et le voir.

S'il te plait, laisse-nous un commentaire ou publie une photo sur

#mywalkeredisonhome

¡Enhorabuena por sus nuevos muebles!

Nos encantaría oírlo y verlo.

Por favor, déjenos un comentario o publique una foto con

#mywalkeredisonhome

Assembler des meubles peut parfois être compliqué.

Notre équipe de service client, située dans l'Utah, est là pour obtenir des informations sur les produits, aider pour l'assemblage d'un produit ou pour tout autre problème de support client.

Appelle-nous **801-433-3008**

Envoie-nous les e-mails à service@walkeredison.com

walkeredison.com/pages/customer-service

Nous sommes disponibles pour t'aider du Lundi au Jeudi de 8 am - 5 pm, Vendredi de 8 am - 3 pm MST.

Pour plus de détails sur les vidéos d'assemblage, les instructions d'assemblage, les pièces de rechange et le service client.

NUMÉRISER ICI.



Pour le nettoyage, n'utilise jamais d'abrasifs, utilise un chiffon doux et de l'eau avec du savon neutre pour nettoyer les meubles.

A veces, montar muebles puede resultar complicado.

Nuestro equipo de atención al cliente, ubicado en Utah, está a su disposición para informarle sobre los productos, ayudarle a montarlos o resolver cualquier otro problema de atención al cliente.

Llámenos **801-433-3008**

Envíenos un correo electrónico a service@walkeredison.com

Visite nuestra página web de atención al cliente

walkeredison.com/pages/customer-service

Estamos a su disposición para ayudarle de lunes a jueves de 8:00 a 17:00, viernes de 8:00 a 15:00 MST.

Para más detalles sobre videos de montaje, instrucciones de montaje, piezas de recambio y servicio de atención al cliente

ESCANEE AQUÍ



Para la limpieza, nunca utilice productos abrasivos, utilice un paño suave y agua con jabón neutro para limpiar los muebles.