

ASSEMBLY INSTRUCTION

SOFA TABLE

A Table Top



1 PC

B Leg



4 PCS

C Connecting Rod



1 PC

D Iron
2-11/16"*7/8"*1-9/16"



2 PCS

E Bolt
1/4"*3/4"



12 PCS

F Hexagon Bolt
1/4"*3/4"



8 PCS

G Spring Washer
1/4"



20 PCS

H Flat Washer
1/4"



20 PCS

I Allen Key
M4



1 PC

J Wrench
10#



1PC

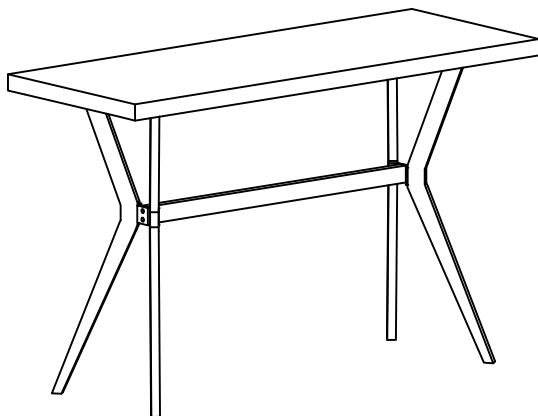

This page lists all the contents included in the box. Please take the time to identify the hardware as well as the individual components to this product. As you unpack and prepare for assembly, place the contents on a carpeted or padded area to protect them from damage.

1 Attach Leg (B) to bottom of Table Top (A) using Bolt (E), Spring Washer (G), Flat Washer (H) with Allen Key (I).

Note: At this step, do not fully tighten the bolts.

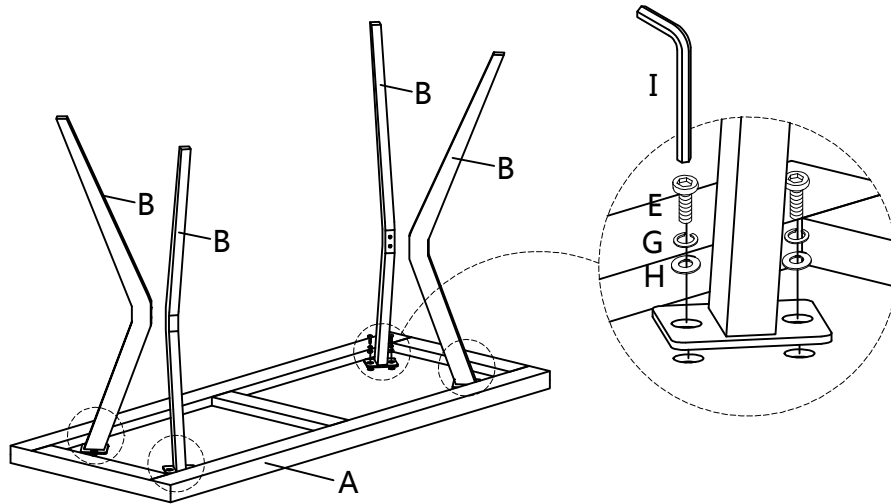

2 Attach Iron (D) to Leg (B) using Bolt (F), Spring Washer (G), Flat Washer (H) with Wrench (J).

Note: At this step, fully tighten all bolts at all bolts at all joints in a sequential manner.

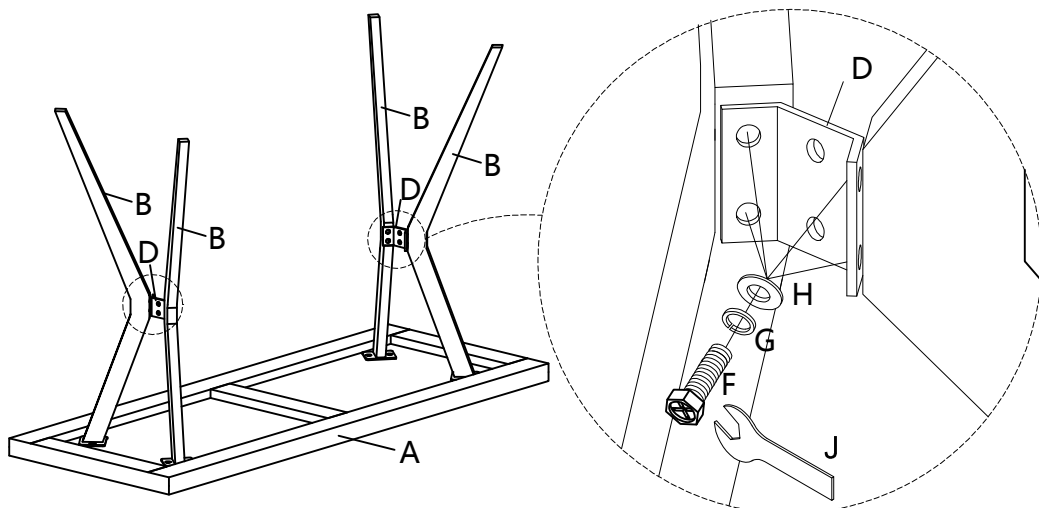

3 Attach Connecting Rod (C) to Iron (D) using Bolt (E), Spring Washer (G), Flat Washer (H) with Allen Key (I).

Note: Align the bolts with holes then tighten them at Step 3 firstly. Then fully tighten the bolts from Step 1.

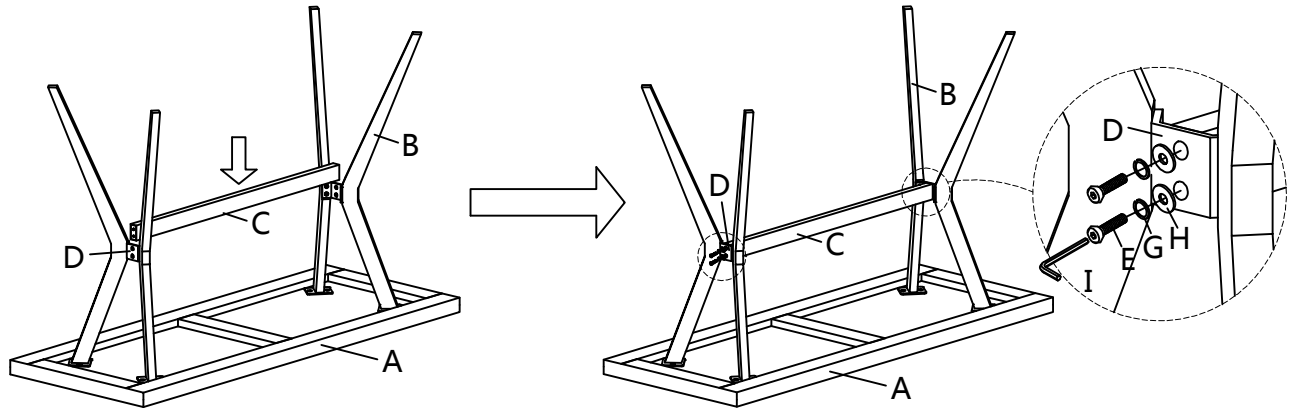

4 With assistance from your adult partners, turn the Sofa Table right way up. Adjust the Pre-installed Levelers on the bottom of Leg (B) until the Sofa Table is level with the ground.

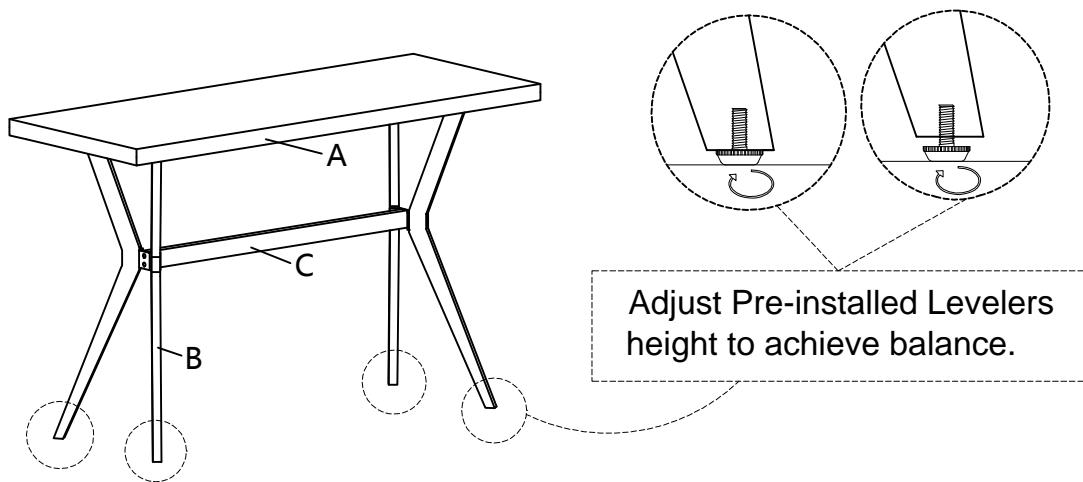

Cleaning & Care

Treat surface with care. Surface is resistant to scratches but is not scratch resistant. Clean surfaces with a dry or damp soft cloth. Do not use abrasive cleaners. Hardware may loosen over time. Periodically check that all connections are tight.