

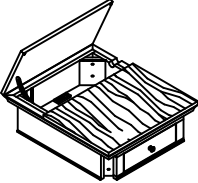







# ASSEMBLY INSTRUCTION

## END TABLE WITH POWER OUTLET

<b>A</b> Top Panel  1PC	<b>B</b> Bottom Shelf  1PC	<b>C</b> Metal Leg  4PCS	<b>D</b> Bolt ø1/4"X1-3/4"  12PCS
<b>E</b> Spring Washer 1/4"  12PCS	<b>F</b> Flat Washer 1/4"X16mm  12PCS	<b>G</b> Wrench 4mm  1PC	<b>H</b> Plastic Cap  4PCS

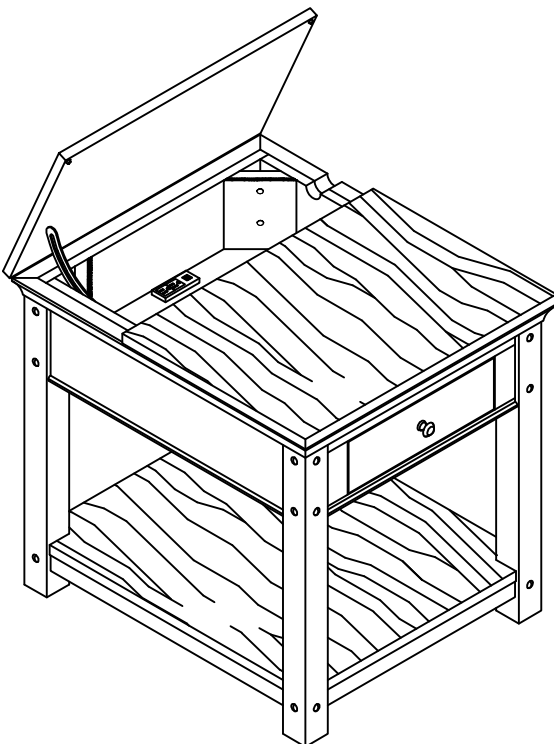

This page lists all the contents included in the box. Please take the time to identify the hardware as well as the individual components to this product. As you unpack and prepare for assembly, place the contents on a carpeted or padded area to protect them from damage.

- 1** Pull out the drawer from Top Panel (A). Lift the top, and attach 2pcs Metal Leg (C) to Top Panel (A) using Bolt (D), Spring Washer (E), Flat Washer (F) by Wrench (G), then lid Plastic Cap (H) on it.

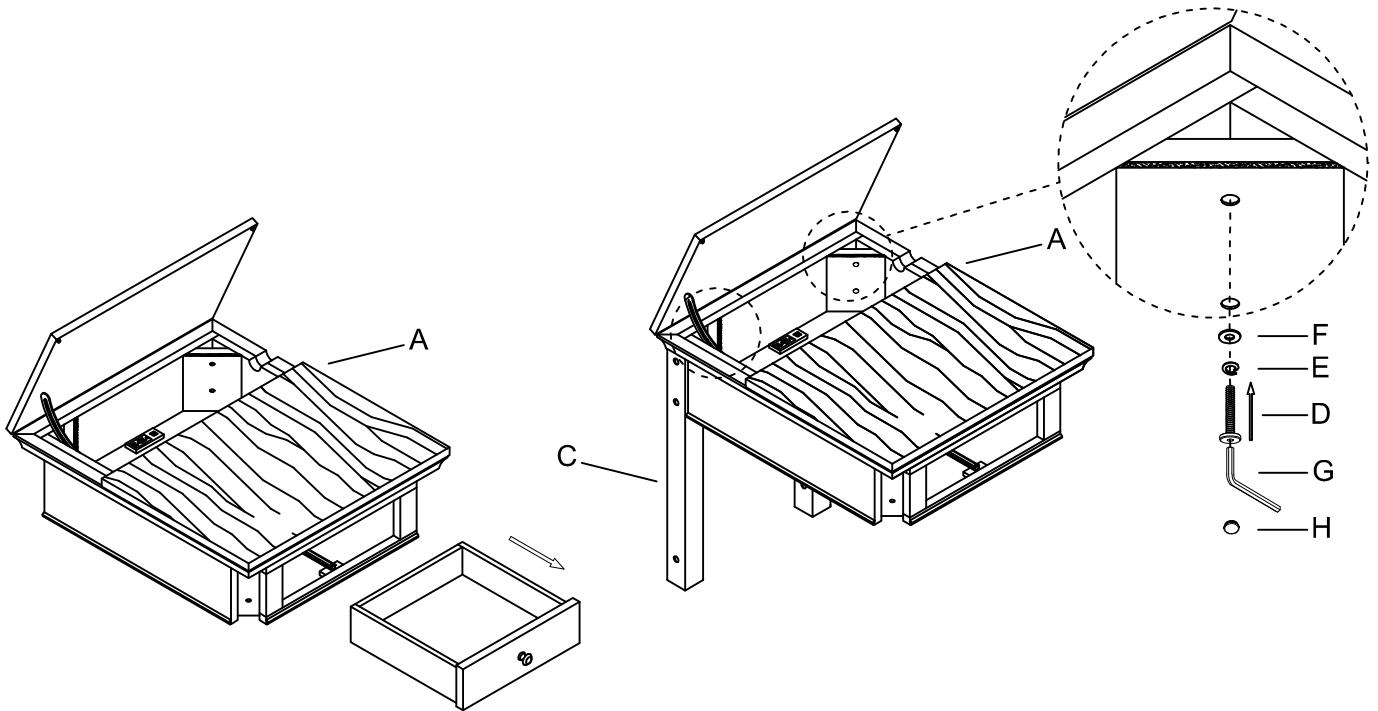

- 2** Turn the assembled unit down and attach the 3rd Metal Leg (C) to the Top Panel (A) using Bolt (D), Spring Washer (E) and Flat Washer (F) by Wrench (G).

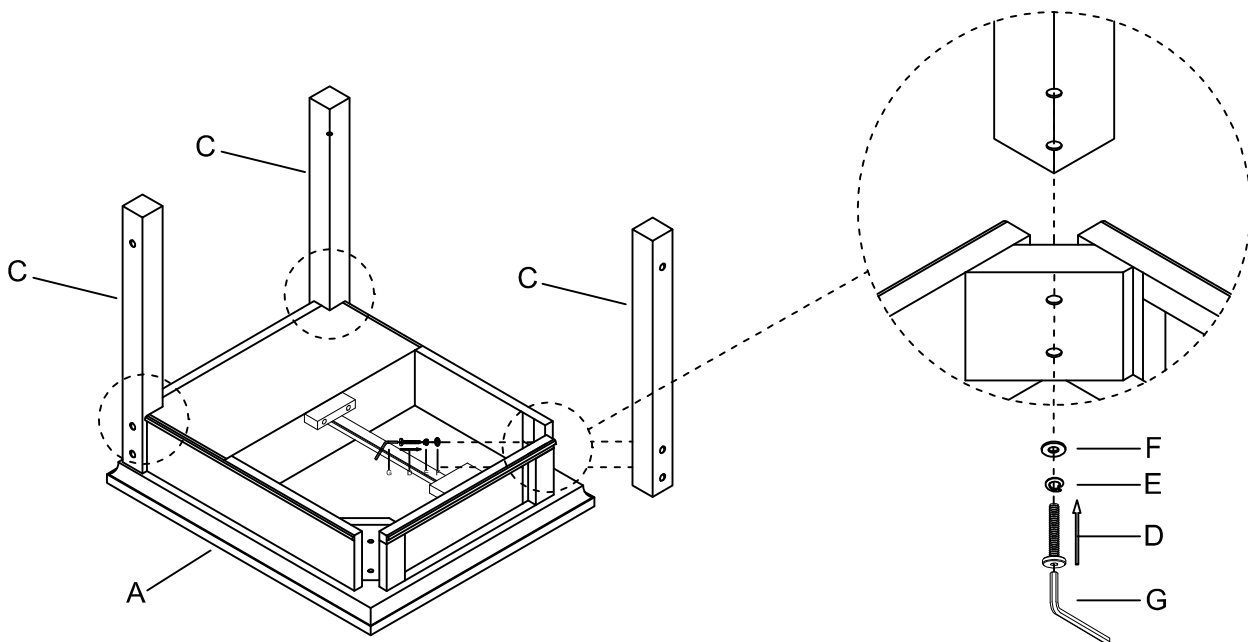

- 3** Attach the Bottom Shelf (B) to the 3pcs Metal Leg (C) using Bolt (D), Spring Washer (E) and Flat Washer (F) by Wrench (G). Then attach the 4th Metal Leg (C) to both Bottom Shelf (B) and Top Panel (A) by the same method. Finally lock them up to 100%.

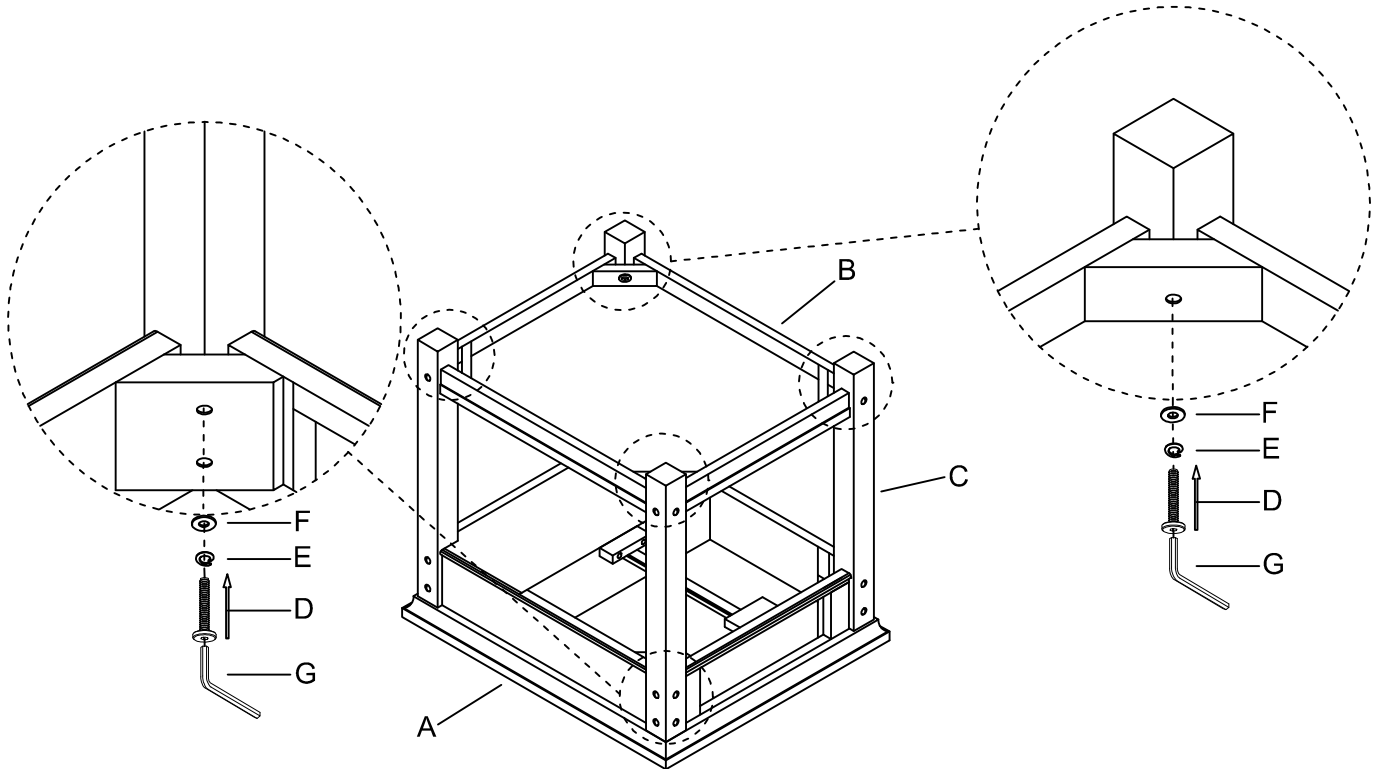

- 4** Turn over the table and put the drawer in.

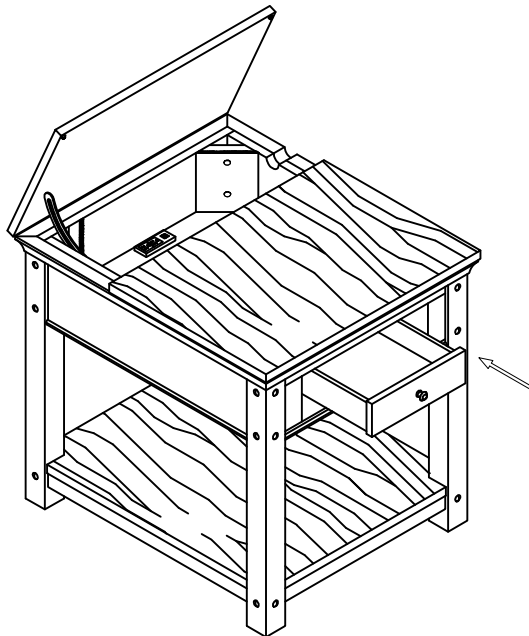





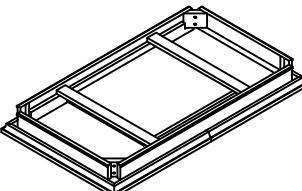
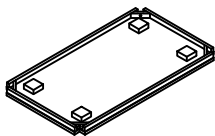
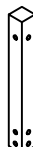

#### Cleaning & Care

Treat surfaces with care. Surfaces are resistant to scratches but are not scratch resistant. Clean surfaces with a dry or damp soft cloth. Do not use abrasive cleaners. Hardware may loosen over time. Periodically check that all connections are tight.

# ASSEMBLY INSTRUCTION

## LIFT-TOP COFFEE TABLE

<b>A</b> Top Panel  1PC	<b>B</b> Bottom Shelf  1PC	<b>C</b> Metal Leg  4PCS	<b>D</b> Bolt $\phi 1/4" \times 1-3/4"$  12PCS
<b>E</b> Spring Washer $1/4"$  12PCS	<b>F</b> Flat Washer $1/4" \times 16\text{mm}$  12PCS	<b>G</b> Wrench $4\text{mm}$  1PC	<b>H</b> Caster $2"$  4PCS
<b>I</b> Screw $\#8 \times 3/4"$  16PCS			

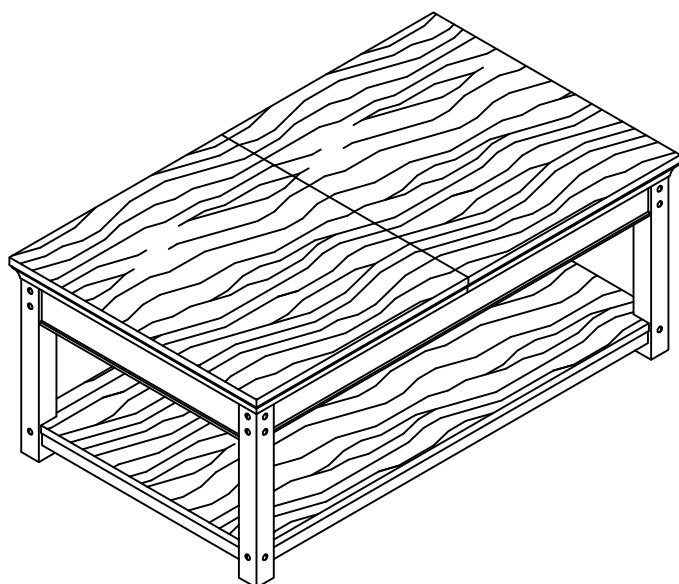

This page lists all the contents included in the box. Please take the time to identify the hardware as well as the individual components to this product. As you unpack and prepare for assembly, place the contents on a carpeted or padded area to protect them from damage.

**1** Attach 3pcs Metal Leg (C) to Top Panel (A) using Bolt (D), Spring Washer (E) and Flat Washer (F) by Wrench (G).

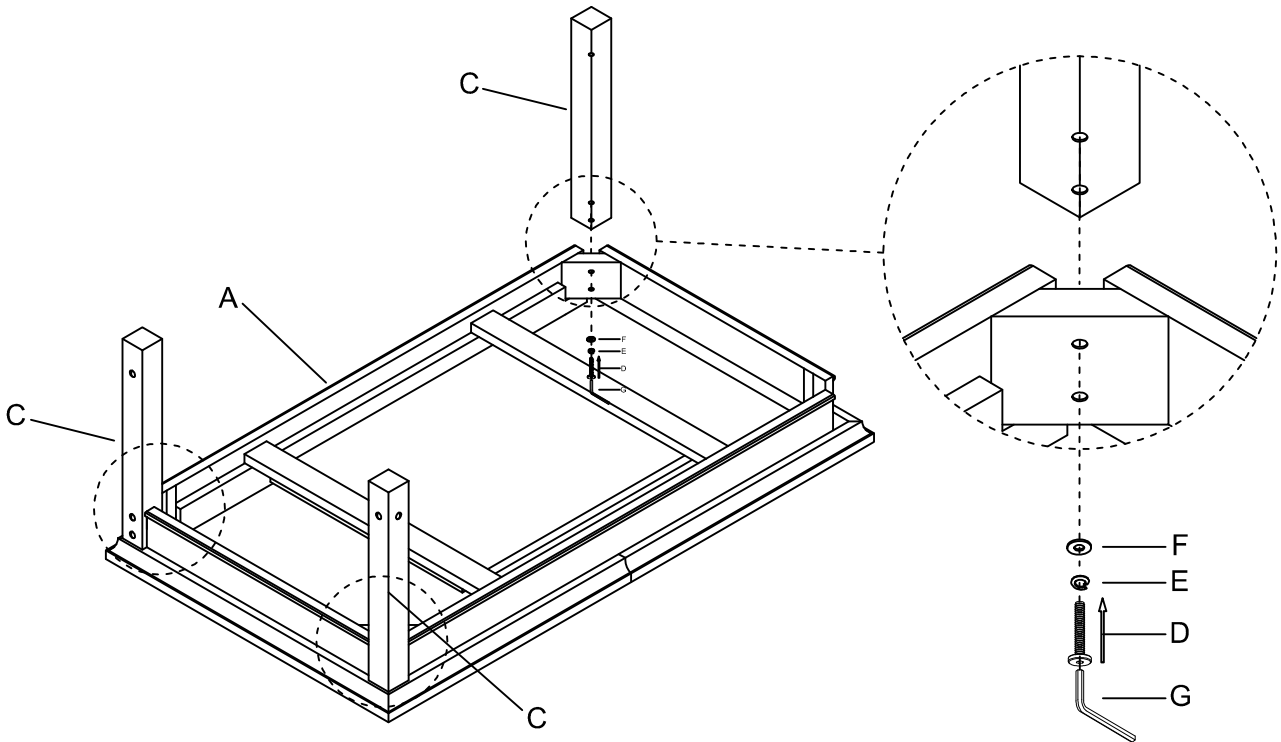

**2** Attach Bottom Shelf (B) to 3pcs Metal Leg (C) using Bolt (D), Spring Washer (E) and Flat Washer (F) by Wrench (G). Then attach the 4th Metal Leg (C) to both Bottom Shelf (B) and Top Panel (A) by the same method. Finally attach Caster (H) to the Bottom Shelf (B) by using Screw (I) with Screwdriver (not provided).

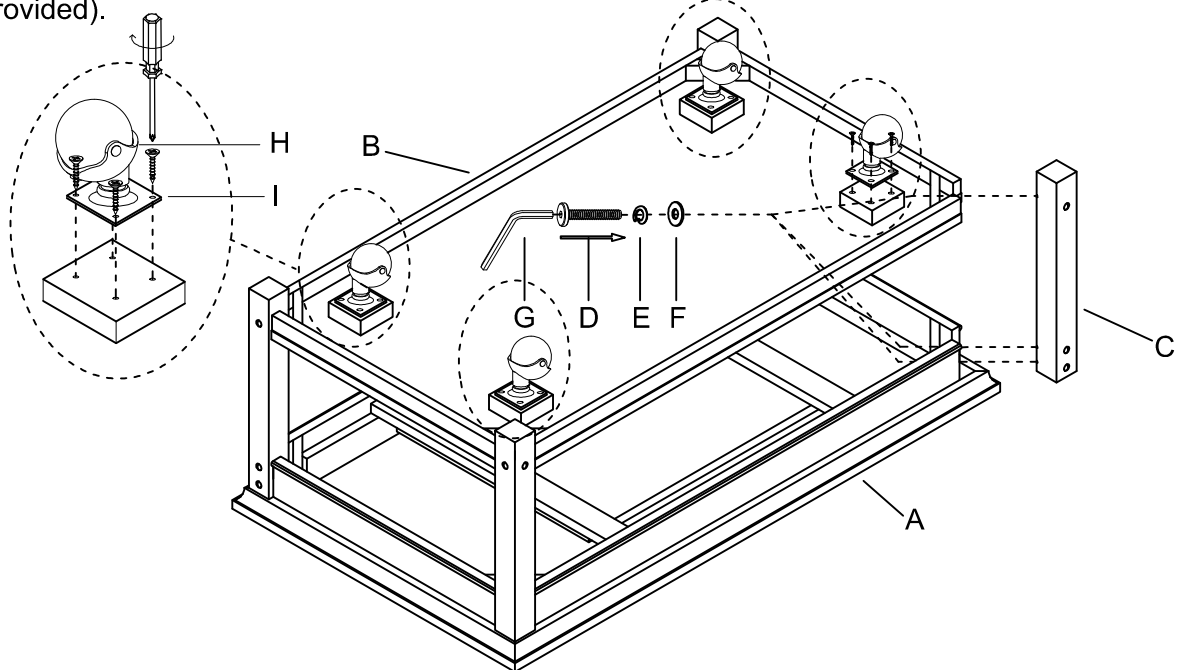

#### Cleaning & Care

Treat surfaces with care. Surfaces are resistant to scratches but are not scratch resistant. Clean surfaces with a dry or damp soft cloth. Do not use abrasive cleaners. Hardware may loosen over time. Periodically check that all connections are tight.