

Operating Instructions for the Thermal Stripper

1. General

1.1 This procedure provides operating instructions for the Corning Cable Systems Thermal Stripper (p/n Mass-Stripper). Using the appropriate fiber handler, the stripper can remove the ribbon matrix of ribbon fibers ranging from 2 to 12 fibers, and remove the coating from single fibers.

1.2 This issue includes updated corporate information.

2. Precautions

WARNING: *As with all electrically powered equipment, use caution when operating this device. Without proper grounding, accessible conductive parts could render an electric shock.*

WARNING: *To avoid electric shock, use only the power cord specified for the unit. Use only power cords which are in good condition. Do not unplug the unit by pulling on the power cord - doing so may damage the cord.*

CAUTION: *To reduce the chance of a short circuit when using external power supplies, always plug a power cord's barrel connector into the stripper **first**, and then the cord's other end into a DC outlet.*

WARNING: *Never allow the stripper or its power supply to be immersed or get wet. Do not unplug the unit with wet hands.*

WARNING: *Hot surfaces may cause burns - do not touch the heater area of the stripper.*

CAUTION: *Do not operate this unit in temperatures less than 0° C (32° F) or more than 40° C (104° F).*

WARNING: *This unit is not designed for use in an explosive atmosphere. Do not use the stripper in dusty or humid areas, or on work surfaces subject to vibrations.*

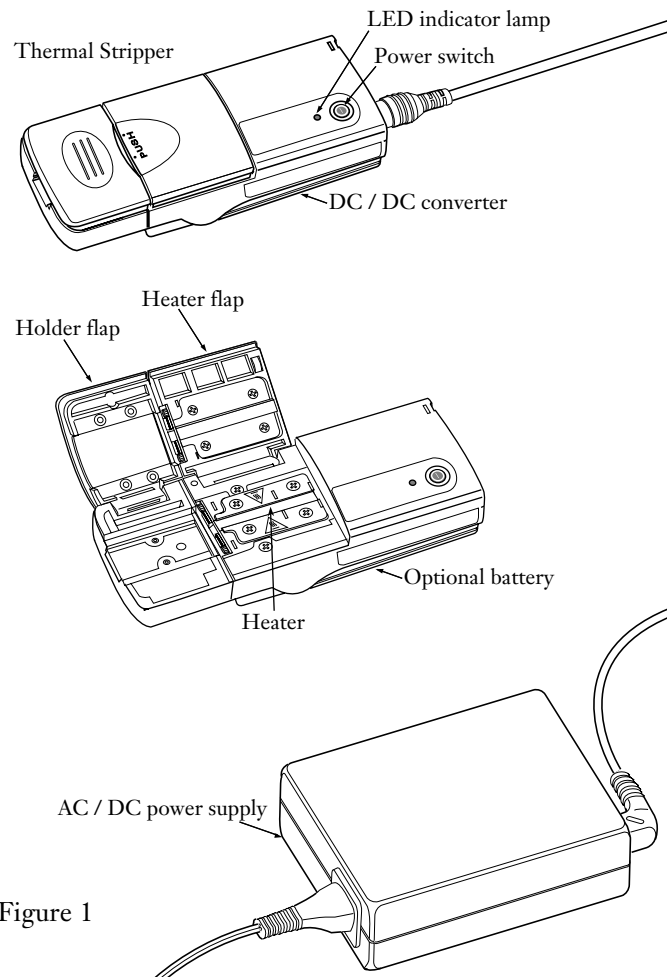

Figure 1

WARNING: *At the first sign of strange smells, extra high temperature, smoke, or abnormal sounds from the stripper, power it off and disconnect it from its AC power supply. Continued operation may cause fire or electrical shock. Call Corning Cable Systems for repair information.*

3. Power Sources and Adjustable Settings

3.1 The stripper may be powered by either the 7.4 VDC battery provided (p/n 2814075-01), an external 12 VDC source such as a fusion splicers's DC output jack, or by the AC / DC power supply which is also supplied with the stripper (Figure 1).

When using an external 12VDC source or AC/DC power supply, it is not necessary to have the battery installed to use the stripper.

Operation from the Battery

3.2 Install the battery as shown in Figure 2.

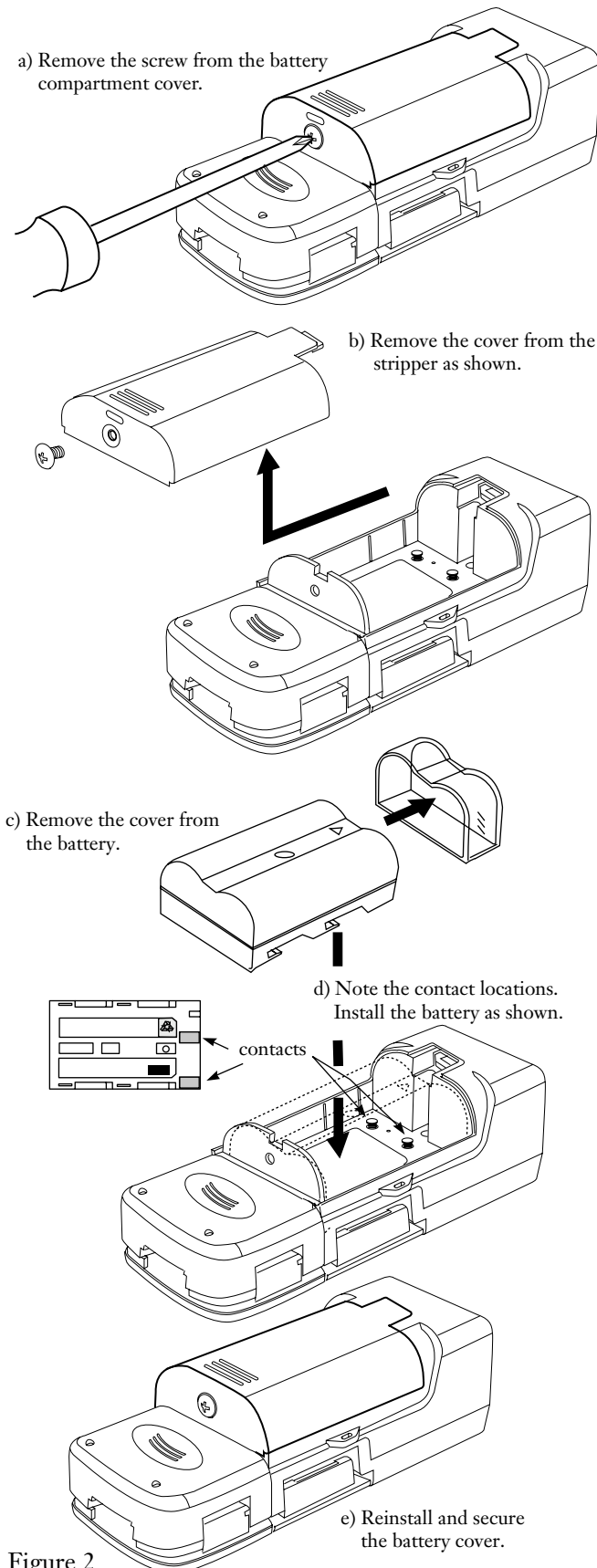

Figure 2

3.3. To charge the battery, connect the DC cord from the AC/DC power supply into the stripper's DC power jack and then plug the power supply's AC cord into an AC power outlet. The stripper's charger LED will come on (Figure 3). After approximately 150 minutes, the battery will be fully charged and the LED will go out.

Note: *The battery may be charged when using the stripper, but the charging rate will be ten times slower.*

WARNING: *If the charging indicator LED blinks, there is a problem with unit which could lead to electrical shock or a fire. Immediately turn off and unplug the unit. Contact Corning Cable Systems for assistance.*

3.4 Normal battery operation of the stripper is approximately 5 hours. A "Save" mode incorporated in the stripper can maximize battery life between charges. Flip the switch from its factory-set "NORM" position to "SAVE" to access this feature (Figure 3).

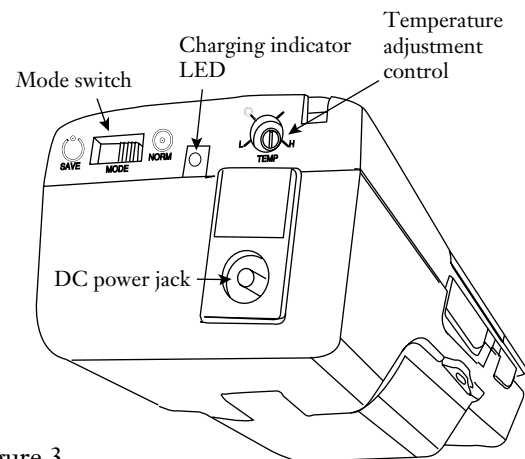

Figure 3

3.5 The automatic "Save" mode will cut the power consumption and lower the stripper's temperature between stripping operations, as indicated by the LED on the top of the stripper (see Figure 4) changing from green to red.

Open the heater flap to return the stripper back to operating temperature. The LED will switch to green when the stripper is ready for use.

Operation from a Fusion Splicer's DC Output Jack

3.6 Use the DC cord to operate the stripper from a fusion splicer's DC output jack. Insert one plug into the Thermal Stripper's DC power jack and the other plug into the splicer's DC output jack.

Operation with the AC / DC Power Supply

3.7 Plug the DC barrel plug from the AC/DC power supply into the stripper (see Figure 4) and the power supply's blade-type plug into a 85-264 VAC 50-60m Hz power source.

Temperature Settings

3.8 The operating temperature of the Thermal Stripper's heater is factory-set for optimal performance. To increase or decrease the temperature, use a small slotted screwdriver to rotate the temperature adjustment control (see Figure 3).

4. Operation

4.1 Turn on the stripper by pressing the green power switch. (Figure 4) The LED indicator lamp will remain red until the unit reaches its operating temperature in approximately 15 seconds and then turn green.

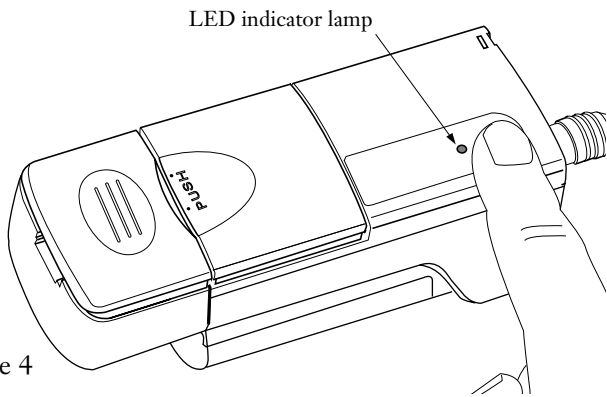

Figure 4

The Thermal Stripper will automatically shut off after 15 minutes of non-use.

Note: To view the stripper's battery status, press down on the power switch for 2 seconds. The green/red LED will indicate the battery status as follows:

Remaining %	100 — 90 — 70 — 20 —
LED	Green Green Blinking Red Blinking Red

4.2 Insert one of the ribbons or fiber through a splice protector sleeve. Slide the sleeve out of the way (Figure 5).

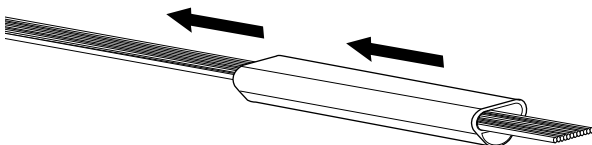

Figure 5

4.3. Select the proper handler. Insert the ribbon / fiber into the handler, leaving approximately 2.54 cm (1 in.) exposed from the end. *Be sure to place the blue fiber in a ribbon closest to the hinge of the handler.*

Close the handler (Figure 6).

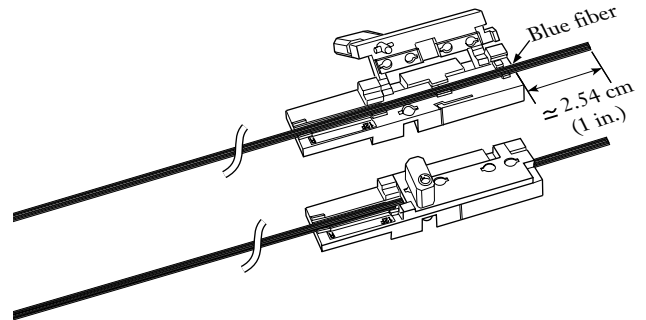

Figure 6

4.4. If the LED has turned from red to green, open the flaps on the Thermal Stripper.

Insert the handler into the stripper, making sure that the ribbon is properly positioned on the heater (Figure 7).

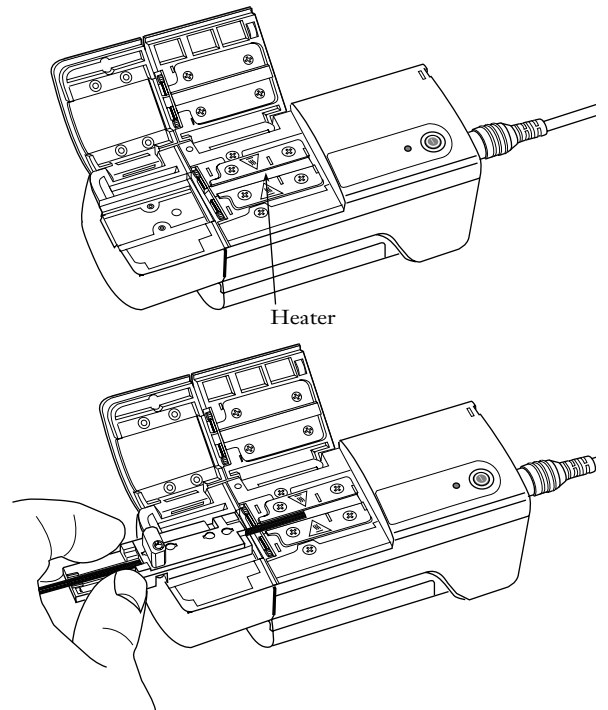

Figure 7

4.5 Close the heater flap and then the holder flap on the stripper.

Wait 5 seconds, press firmly on both flaps, and then pull slowly to remove the coating from the fiber (Figure 8).

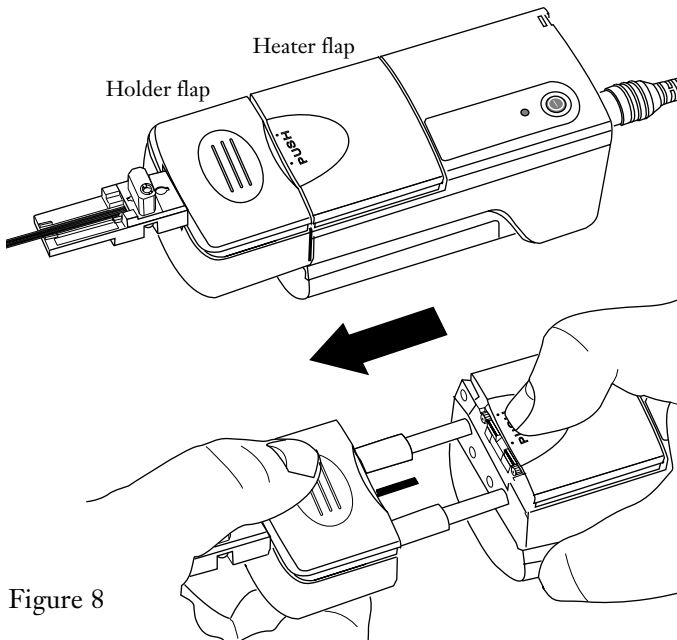

Figure 8

4.6 Open the flaps and remove the handler (Figure 9).

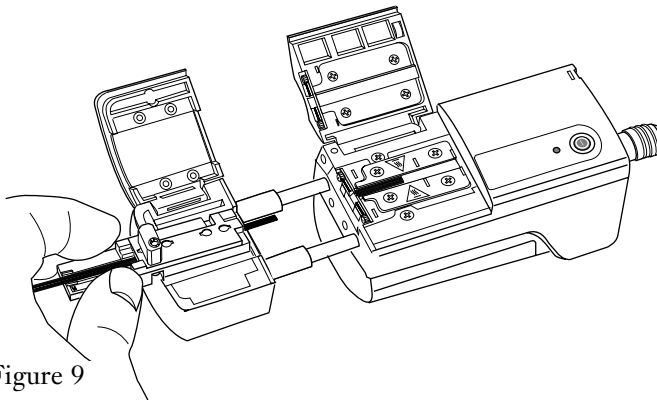

Figure 9

4.7 Thoroughly clean the stripper with a brush, removing the stripped coating from the heating element, blade, and flaps (Figure 10).

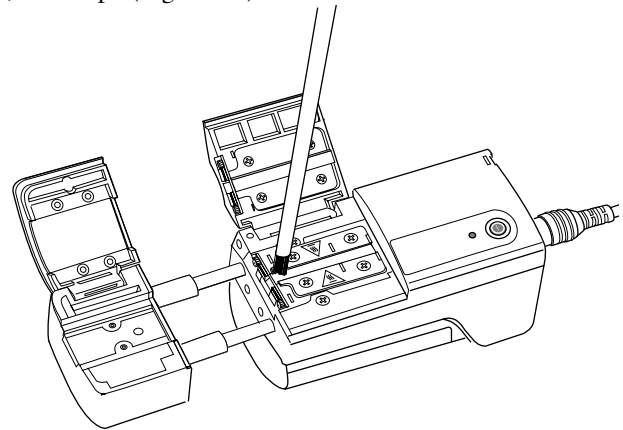

Figure 10

4.8. Repeat steps 4.3 through 4.7 on the other ribbon fiber(s) to be spliced.

*Special Note:
Fiber Optic
Training
Program*



Corning Cable Systems offers comprehensive, integrated training programs. Courses are structured for: Telephony, CATV, LAN, Intelligent Transportation Systems and Power Utilities.

For information on Engineering Services Training call: 800-743-2671.

Corning Cable Systems reserves the right to improve, enhance, and modify the features and specifications of Corning Cable Systems' products without prior notification.

All trademarks are the property of their respective holders

Corning Cable Systems is ISO 9001 certified.

© 2007 Corning Cable Systems. All rights reserved.

Printed in U.S.A.

Corning Cable Systems LLC
PO Box 489
Hickory, NC 28603-0489 USA
For US and Canada 1-800-743-2673
International 828-901-5000
FAX: 828-901-5973
<http://www.corning.com/cablesystems>