

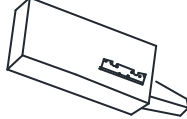

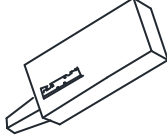
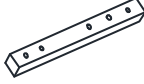

# ASSEMBLY INSTRUCTION

## E208B FULL QUEEN AND KING HEADBOARD

---

<b>A</b> Headboard  1pc	<b>B</b> Left Wooden Frame  1pc	<b>C</b> Right Wooden Frame  1pc	<b>D</b> Slate  2pcs	<b>E</b> Bolt 1/4" x 65mm  10pcs
<b>F</b> Flat Washer  10pcs	<b>G</b> Lock Washer  10pcs	<b>H</b> Allen Wrench  10pcs		

---

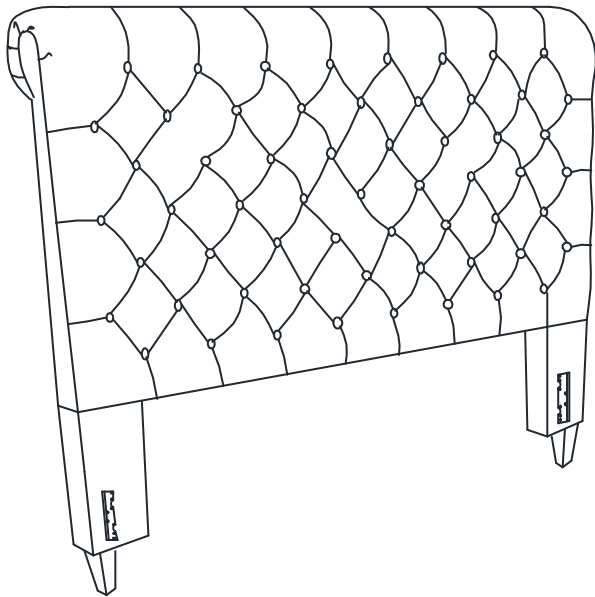

This page lists all the contents included in the box. Please take the time to identify the hardware as well as the individual components to this product. As you unpack and prepare for assembly, place the contents on a carpeted or padded area to protect them from damage.

1

Attached left Wooden Frame (B) and right Wooden Frame (C) to the Headboard (A) use Bolt (E), Lock Washer (G) and Flat Washer (F) on holes of Slates (D). Turn the Allen Wrench (H) in Bolt (E).

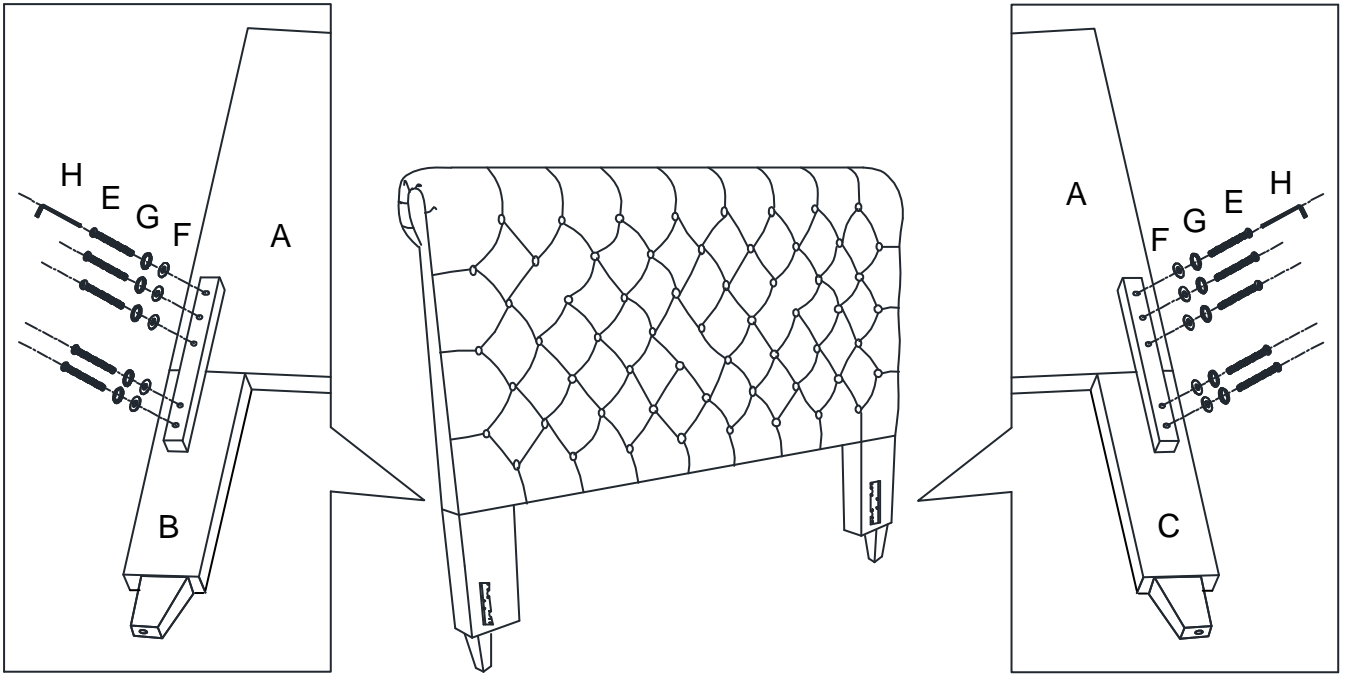

### Cleaning & Care

Treat surface with care. Surface is resistant to scratches but is not scratch resistant. Clean surfaces with a dry or damp soft cloth. Do not use abrasive cleaners. Hardware may loosen over time. Periodically check that all connections are tight.

# ASSEMBLY INSTRUCTION

## 315B WINGBACK QUEEN AND FULL BED WITH REGULAR SLATS

**A** Footboard      **B** Side Rails      **C** Wooden Leg      **D** Support Leg      **E** Wooden Slat



1 pc

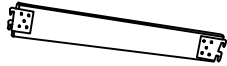

2 pcs

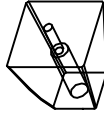

2 pcs



6 pcs

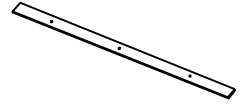

3 pcs

**F** Screw      **G** Bolt 1/4" x 75mm      **H** Bolt 1/4" x 50mm      **I** Flat Washer      **J** Lock Washer



12 pcs



2 pcs



6 pcs



8 pcs



8 pcs

**K** Allen Wrench



1 pc

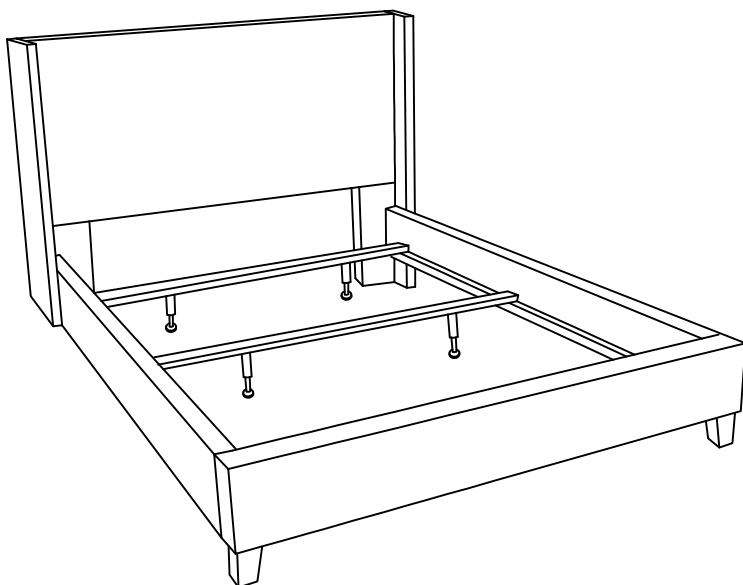

This page lists all the contents included in the box. Please take the time to identify the hardware as well as the individual components to this product. As you unpack and prepare for assembly, place the contents on a carpeted or padded area to protect them from damage.

- 1** Attached Wooden Leg (C) to the Footboard (A) use Bolt (G), Lock Washer (J) and Flat Washer (I) on both of holes. Turn the Allen Wrench (K) in Bolt (G).

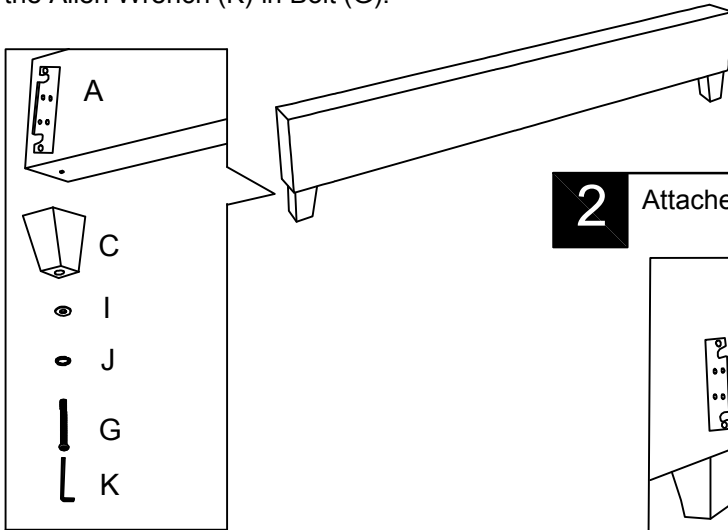

- 2** Attached Side Rail (B) to the Headboard and Footboard (A).

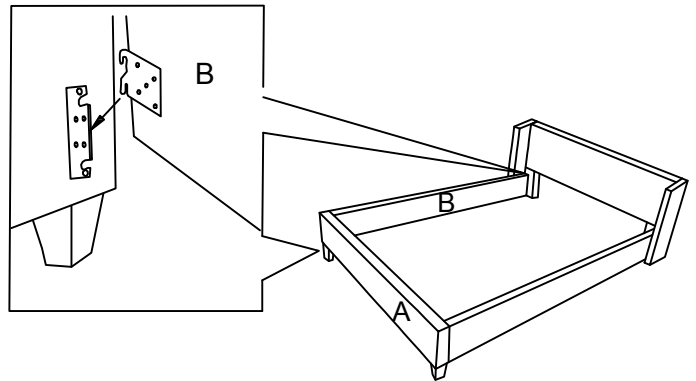

- 3** Assembly Wooden Slats (E) and Support Leg (D) use Flat Washer (I), Lock Washer (J) and Bolt (H), Turn the Allen Wrench (K) in Bolt (H).

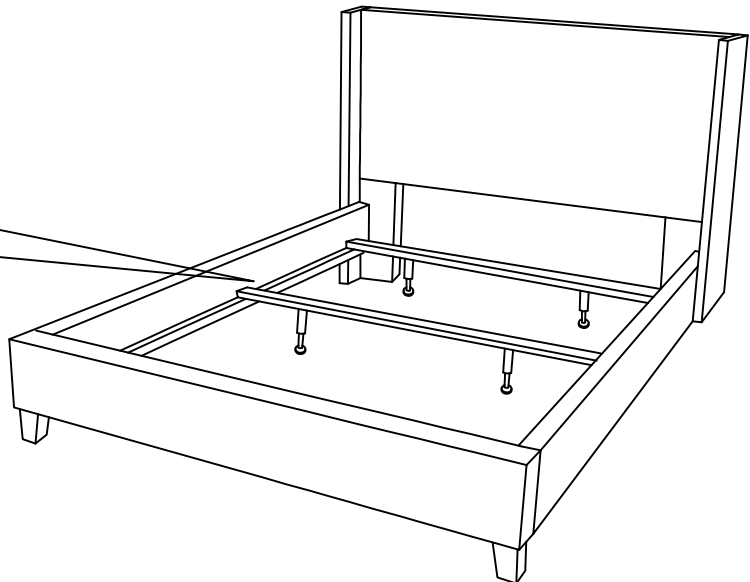
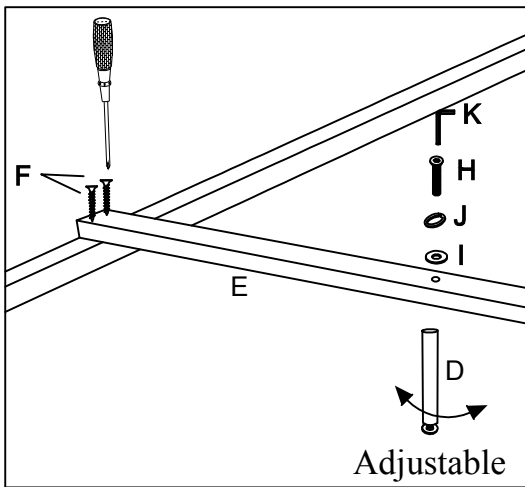

### Cleaning & Care

Treat surface with care. Surface is resistant to scratches but is not scratch resistant. Clean surfaces with a dry or damp soft cloth. Do not use abrasive cleaners. Hardware may loosen over time. Periodically check that all connections are tight.