

Installation instructions for Sliding Cavity Door Lock

385 Square Privacy, 387 Square Connecting, 395 Circular Privacy
& 397 Circular Connecting (Refer to drawing on reverse)

Step 1. Door Preparation

- Fold template where indicated.
- Position template on door edge at desired latch height.
- Firmly hold template and mark latch height and escutcheon hole centre at required backset. (refer template).
- Measure door thickness and mark centre.
- Drill 25mm (1") latch hole.
- Note:** it is important to drill this hole squarely.
- At required backset drill pilot hole – suggested size 3mm (1/8").
- Enlarge hole to 54mm (2 1/8") as required, drilling from both sides of the door.

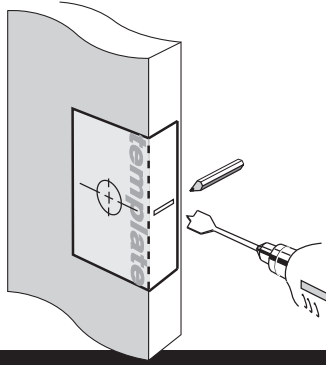

Important Note

- A. Do not operate latch before installation. The latch should be left extended with the pull tab in place until fitted in door (Please see reverse).
- B. Maximum door gap – 2.0mm. This is the biggest door gap the latch will secure. Please ensure gap is no bigger by adjusting door prior to fitting latch.

Step 3. Assembly of Escutcheons

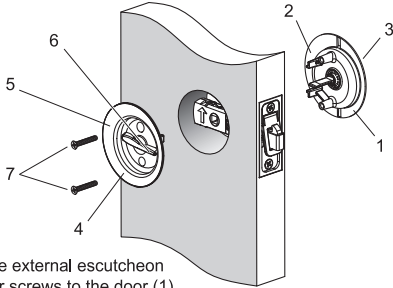

- Assemble the external escutcheon with posts for screws to the door (1).
- Put wide face away from door edge (2).
- Put small turnbutton point forwards – if a turnbutton (6).
- Assemble the internal escutcheon with screw holes to the door (4).
- Put wide face away from door edge (5).
- Put small turnbutton point forwards – if a turnbutton (3).
- Fasten escutcheons with screws provided (7).
- Check the latch moves freely – readjust escutcheons if required.

Step 2. Latch Installation

- Mark and chisel latch faceplate (8) to a recess of 4mm. Use latch faceplate as a template.
- Insert latch (9) into door with hook pointing upwards.
- Fasten with two screws (10) provided. If pull tab (11) doesn't move freely unscrew the latch and clear wood from behind the pull tab hinge.
- Refasten and check pull tab is free.

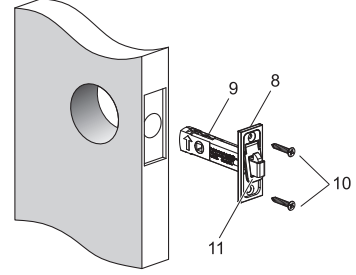

Step 4. Door Jamb Preparation

- Place the strike plate (12) on end of extended latch (14) and close door so the strike plate touches the jamb.
- Keeping the strike plate aperture evenly spaced around the latch, use the strike plate as a template to mark a cut-out on the jamb.
- Chisel the strike plate recess to a depth of 1.6mm.

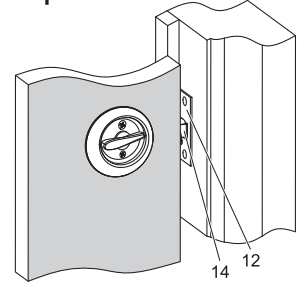

Important Note

For correct installation, ensure that the Schlage inscription is at top of strike.

Step 5. Strike Plate Installation

- Using the template provided, drill two 19mm (3/4") diameter holes 15mm (5/8") deep to recess the latchbolt.
- Fit and fasten the strike plate (12) with screws provided (13).

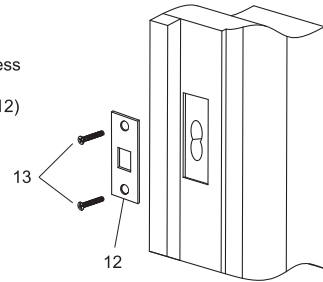

PROBLEMS AFTER FITTING

- A. If the latch won't enter the strike plate, reposition strike plate on jamb.
- B. If the door gap is too big, recess the strike plate deeper into the jamb.



Note: Installation instructions also apply to 385 and 387 Square Sliding Cavity Door Locks

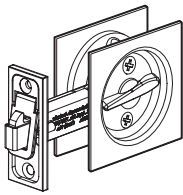

Mark centre-line of latch hole

Mark centre-line of latch hole

Strike Plate Recess in Door Jamb

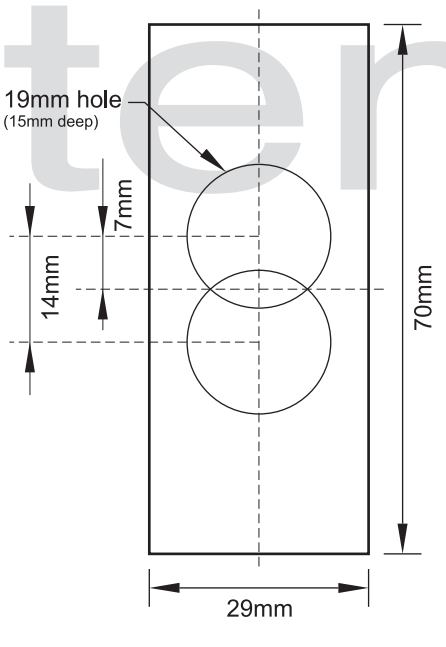

FOLD HERE

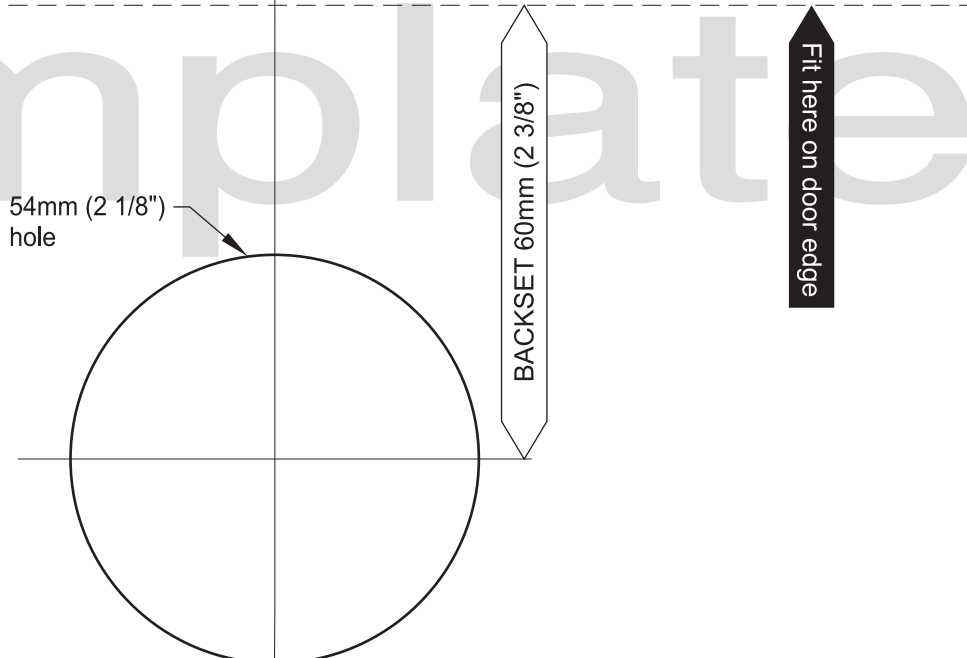

NOTE: Carefully follow these instructions when installing. Do not overtighten screws. Use of power drill is not recommended.

Exploded Diagram

Note: ridge on metal part that locates in groove in plastic part

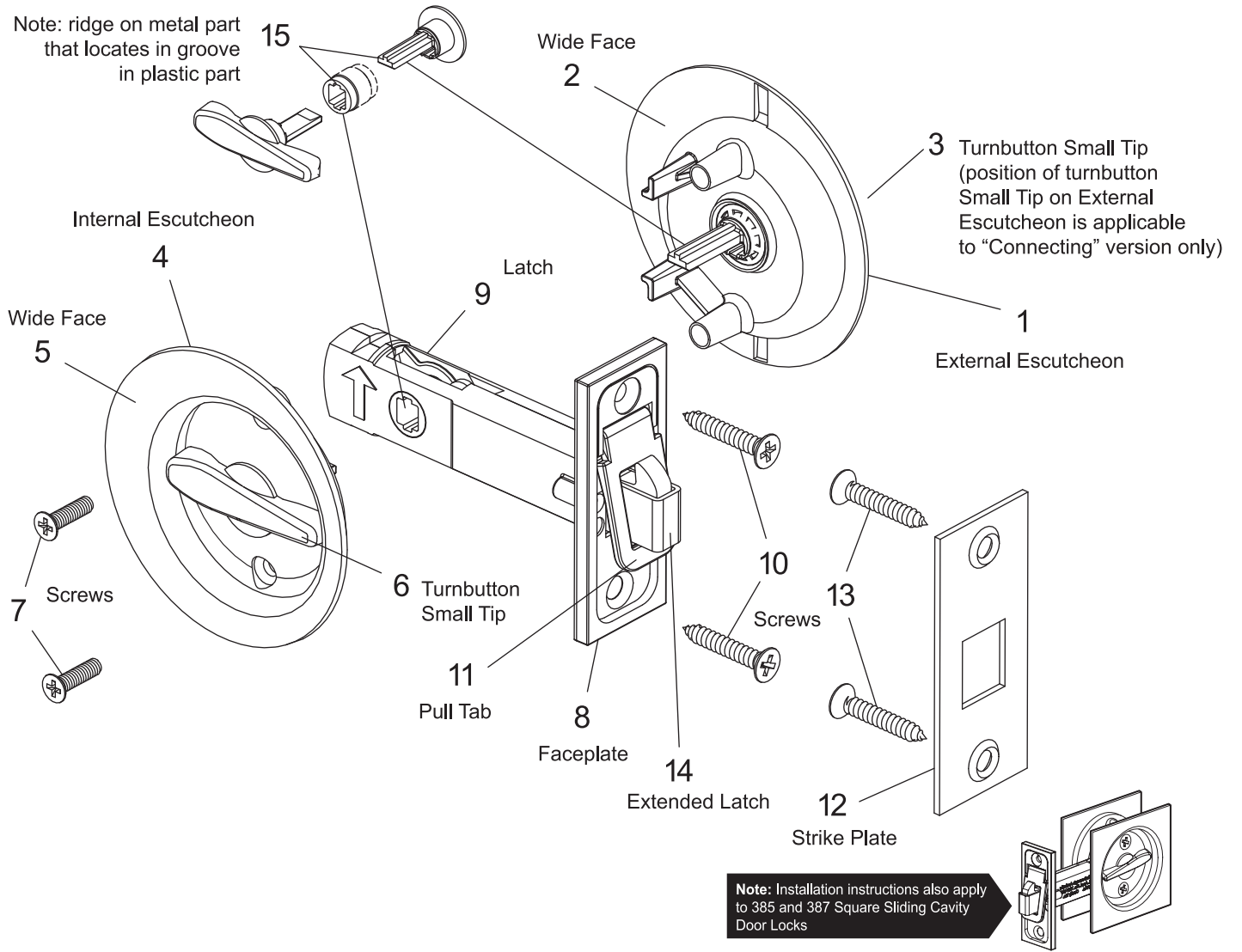

ALLEGION
gainsboroughhardware.com.au
gainsboroughhardware.co.nz

PDGA0029R1 DEC 21