

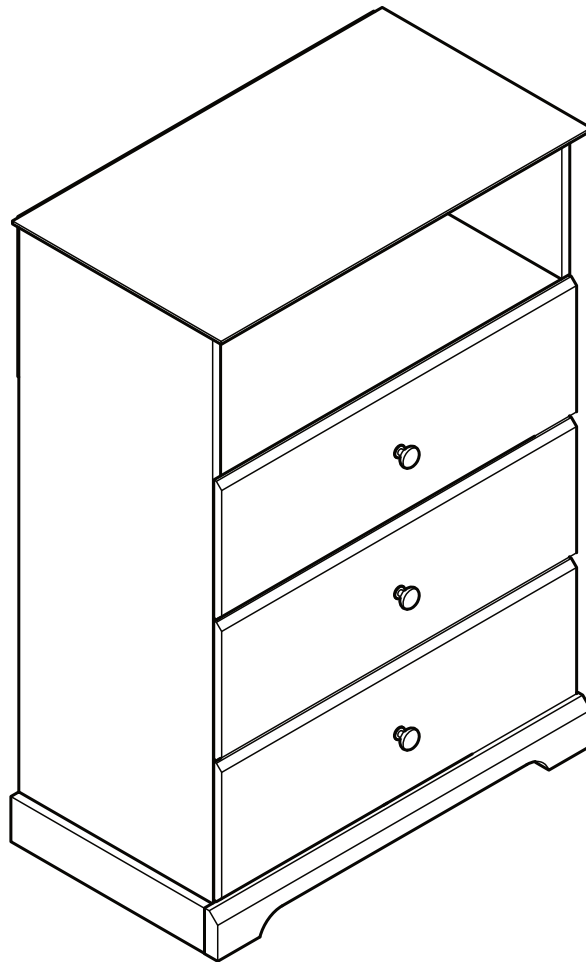

WOOD 3 DRAWER CHEST WITH STORAGE SHELF

PECHO DE MADERA 3 CAJONES CON ESTANTE DE ALMACENAMIENTO

COFFRE À 3 TIROIRS EN BOIS AVEC ÉTAGÈRE DE RANGEMENT



2729-783  
2731-783

Made in Malaysia  
Hecho en Malaysia  
Fabriqué en Malaysia

Examine all packaging material for small parts that may have come loose during shipment. Periodic checks are recommended to ensure that a components are in proper position, tight and free from damage. Keep this assembly instruction for future reference. Adult assembly is required

Examine el material de embalaje en busca de piezas pequeñas que puedan haberse aflojado durante el transporte. Se recomienda realizar verificaciones periódicas para asegurar que todos los componentes estén en la posición correcta, apretados y libres de daños. Guarde estas instrucciones de ensamble para referencias futuras. El ensamble debe ser realizado por un adulto.

Examinez tous les matériaux d'emballage pour les petites pièces qui peuvent avoir été lâche pendant le transport. Des contrôles périodiques sont recommandées afin d'assurer que tous les composants sont en bonne position, tendu et sans dommages. Gardez ces instructions de montage pour référence future. Assemblage par un adulte est requise.

**⚠ DANGER**

• Risk of suffocation! •

Keep any packaging materials away from children.

**⚠ PELIGRO**

¡Riesgo de sofocación!

Mantenga los materiales de embalaje lejos de los niños.

**⚠ DANGER**

• Risque d'asphyxie! •

Maintenez tous les matériaux d'emballage à l'écart des enfants.

**Before Getting Started**

- Read the instructions carefully prior to assembling the product.
- Carefully remove all packaging materials and retain for future use.
- Choose a clean, level, spacious assembly area. Avoid hard surfaces that may damage the product.
- Ensure that you have all required contents for complete assembly.
- Take care when lifting. Assemble the product in close proximity to where you intend to position the item.
- Do not over tighten the screws and bolts and be careful using power tools as they may damage the threads.
- When you have finished assembling the product, place it on a flat surface and make sure it is stable before use.
- Please do not completely tighten bolts and/or screws until assembly is finished.

**Cleaning & Maintenance**

- Keep the product away from direct heat and sunlight.
- Prolonged exposure to heat sources may cause glazing, melting and scorching, or even cause color to fade.
- Regular vacuuming or light brushing helps to remove dirt and prevent soil build-up, which increases the appearance wear.
- Periodically (every 90 days) make sure that the screws are fully tightened.

**Metal Furniture Care Instructions**

- For everyday cleaning, chrome, brass, aluminum, and painted metal surfaces can be kept looking their best by wiping with a slightly damp, soft cotton cloth, or vacuum cleaner brush.
- If soiled, wipe with clean sponge or cloth wrung out of water. Wipe dry with cloth or paper towel to avoid water spots.
- Do not use any harsh abrasives or chemicals to clean any metal surfaces as it may damage the protective coating.
- Metal will rust if the finish is scratched or if your product is exposed to excessive humidity, particularly in salt water locations.
- Liquid spills should be removed immediately. Using a soft clean cloth, blot the spill gently. Avoid rubbing.

**Antes de Comenzar**

- Lea las instrucciones cuidadosamente antes de ensamblar el producto.
- Retire con cuidado todos los materiales de embalaje y consérvelos para usarlos en el futuro.
- Elija un área de ensamblaje limpia, nivelada y espaciosa. Evite las superficies duras que puedan dañar el producto.
- Asegúrese de tener todos los contenidos necesarios para el ensamblaje completo.
- Tenga cuidado al levantar. Arme el producto muy cerca de donde desea colocar el artículo.
- No apriete demasiado los tornillos ni los pernos, y tenga cuidado al usar herramientas eléctricas ya que pueden dañar las roscas.
- Cuando haya terminado de armar el producto, colóquelo en una superficie plana y asegúrese de que sea estable antes de usarlo.
- No apriete completamente los pernos y / o los tornillos hasta que termine el ensamblaje.

**Limpieza y Mantenimiento**

- Mantenga los muebles lejos del calor y la luz solar directa.
- La exposición prolongada a las fuentes de calor causa cristalización, derretimiento, quemadura y decoloración del tapizado.
- Pasar la aspiradora con regularidad o cepillar suavemente ayuda a quitar la suciedad y evitar la acumulación de tierra en las fibras de la tela, que aumentan el desgaste aparente.
- Periódicamente (cada 90 días) asegúrese de que los tornillos estén bien apretados.

**Instrucciones Para el Cuidado de Muebles de Metal**

- Para una limpieza diaria, las superficies de cromo, bronce, aluminio y de metal pintado se mantienen mejor limpiándolas con un trapo de algodón suave, levemente humedecido, un sacudidor o con el cepillo de la aspiradora.
- Si hay manchas límpielas con una esponja o un trapo limpio húmedo (exprimido). Seque completamente con un trapo a una toalla de papel para evitar manchas de agua.
- No utilice productos abrasivos o químicos fuertes para limpiar las superficies de metal. Se puede dañar el revestimiento protector.
- El metal se oxida si se raya el acabado o se exponen los muebles a humedad excesiva, en particular, en locaciones de zonas húmedas o de la zona costera.

**Avant de Commencer**

- Lisez attentivement les instructions avant d'assembler le produit.
- Retirez soigneusement tous les matériaux d'emballage et conservez-les pour tout usage ultérieur.
- Choisissez une zone de montage propre, plane et spacieuse. Évitez les surfaces dures susceptibles d'endommager le produit.
- Assurez-vous d'avoir tout le contenu requis pour l'assemblage complet.
- Faites attention lorsque vous soulevez le produit. Assemblez le produit à proximité de l'endroit où vous souhaitez positionner l'article.
- Ne serrez pas trop les vis et les boulons et soyez prudent avec les outils électriques car ils pourraient endommager le filetage.
- Une fois l'assemblage du produit terminé, placez-le sur une surface plane et assurez-vous qu'il est stable avant utilisation.
- Ne serrez pas complètement les boulons et / ou les vis tant que l'assemblage n'est pas terminé.

**Nettoyage et Entretien**

- Maintenez le produit à l'écart de toute source de chaleur directe et de la lumière directe du soleil.
- Une exposition prolongée à des sources de chaleur est susceptible d'entraîner la cristallisation, la fonte, la combustion ou encore la décoloration du produit.
- Un nettoyage régulier à l'aspirateur ou un léger brossage régulier permet de retirer la saleté et de prévenir l'accumulation de terre, ce qui augmente l'usure apparente.
- Périodiquement (tous les 90 jours), assurez-vous que les vis sont bien serrées.

**Instructions d'Entretien Des Meubles en Métal**

- Pour le nettoyage quotidien de surfaces de métaux tels que le cuivre, le chrome, l'aluminium ou les surfaces métalliques peintes, essuyez à l'aide d'un chiffon doux et légèrement humide en coton ou encore avec une brosse d'aspirateur. Cela vous permettra de maintenir l'apparence de vos meubles.
- Si le meuble est sale, essuyez à l'aide d'une éponge propre ou d'un chiffon essoré. Épongez la surface avec un chiffon sec ou une serviette en papier pour éviter les taches d'eau.
- N'utilisez pas d'abrasifs ou de produits chimiques corrosifs pour nettoyer le métal, puisque cela pourrait abîmer le revêtement protecteur.
- Si la finition est égratignée ou si vos meubles sont exposés à une humidité excessive, particulièrement dans les endroits où il y a de l'eau salée, le métal rouillera.

## English

 <b>WARNING</b>	
	<p><b>Children have died from furniture tipover. To reduce the risk of furniture tipover:</b></p> <ul style="list-style-type: none"><li>- ALWAYS install tipover restraint provided.</li><li>- NEVER put a TV on this product.</li><li>- NEVER allow children to stand, climb or hang on drawers, doors, or shelves.</li><li>- NEVER open more than one drawer at a time.</li><li>- Place heaviest items in the lowest drawers.</li><li>- DO NOT defeat or remove the drawer interlock system.</li></ul>
	<ul style="list-style-type: none"><li>- DO NOT defeat or remove the drawer interlock system.</li></ul>
<p><i>This is a permanent label. Do not remove!</i></p>	

## French

 <b>AVERTISSEMENT</b>	
	<p><b>Des enfants sont morts écrasés par des meubles. Pour réduire le risque de basculement, suivre les consignes suivantes.</b></p> <ul style="list-style-type: none"><li>- TOUJOURS installer le dispositif antibasculement fourni.</li><li>- NE JAMAIS poser de téléviseur sur ce produit.</li><li>- NE JAMAIS laisser un enfant grimper sur les tiroirs, les portes ou les tablettes ni s'y suspendre.</li><li>- NE JAMAIS ouvrir plus d'un tiroir à la fois.</li><li>- Placer les objets les plus lourds dans les tiroirs du bas.</li><li>- Ne pas démonter ou enlever le système de verrouillage des tiroirs.</li></ul>
	<ul style="list-style-type: none"><li>- Ne pas démonter ou enlever le système de verrouillage des tiroirs.</li></ul>
<p><i>Toujours laisser cette étiquette en place. Ne pas la retirer.</i></p>	

## Spanish

 <b>ADVERTENCIA</b>	
	<p><b>Niños han muerto por vuelcos de muebles. Como hacer para reducir el riesgo de vuelcos de muebles:</b></p> <ul style="list-style-type: none"><li>- SIEMPRE instale la restricción de vuelcos provista.</li><li>- NUNCA ponga un televisor en este producto.</li><li>- NUNCA permita que los niños se paren, trepen o cuelguen en cajones, puertas o estantes.</li><li>- NUNCA abra más de un cajón a la vez.</li><li>- Coloque los artículos más pesados en los cajones más bajos.</li><li>- No pase por alto o elimine el sistema de bloqueo de cajones.</li></ul>
	<ul style="list-style-type: none"><li>- No pase por alto o elimine el sistema de bloqueo de cajones.</li></ul>
<p><i>Esta es una etiqueta permanente. ¡No quitar!</i></p>	

# PARTS

## CONTENTS

Before getting started, ensure the package contains the following components:

## CONTENIDO

Antes de comenzar, asegúrese de que el paquete contenga los siguientes componentes:

## CONTENU

Avant de commencer, assurez-vous que l'emballage contient les composants suivants:

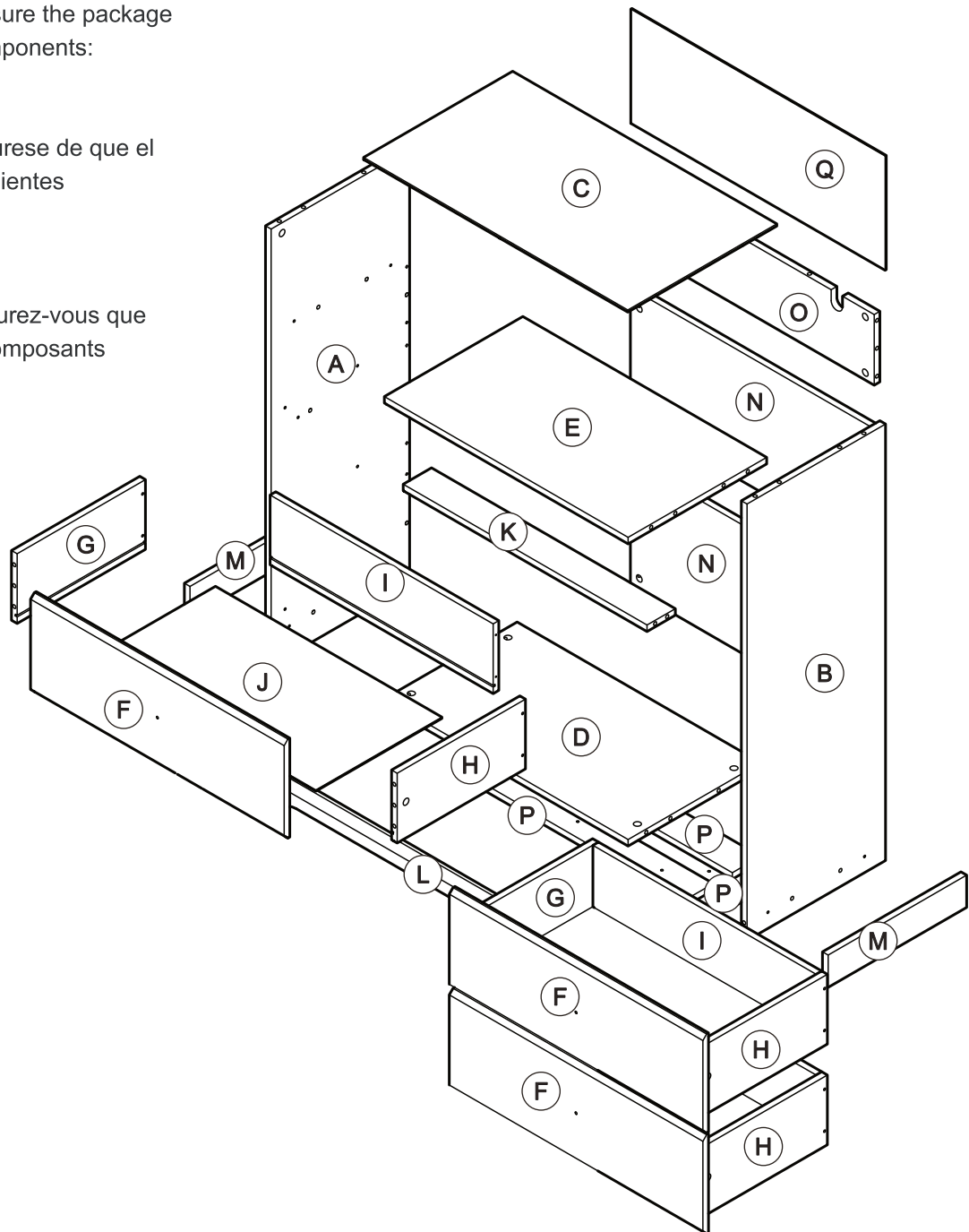

NO.	PART NAME	PIECES
A	Side - L	1
B	Side - R	1
C	Top	1
D	Bottom	1
E	Shelf	1
F	Drawer Front	3
G	Drawer Side L	3
H	Drawer Side R	3
I	Drawer Back	3

NO.	PART NAME	PIECES
J	Drawer Bottom	3
K	Front Support Bar	1
L	Bottom Front Profile	1
M	Bottom Side Bar	2
N	Bottom Back	2
O	Back Center	1
P	Bottom Support Bar	3
Q	Back Top	1

# HARDWARE

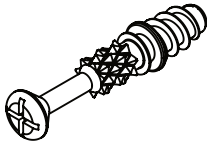

1. Minifix Bolt  
34 x

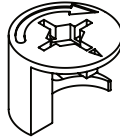

2. Minifix Cam  
34 x

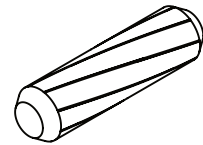

3. Dowel Ø8 x 30mm  
34 x

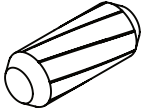

4. Dowel Ø8 x 20mm  
4 x

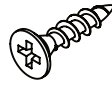

5. Screw M3.5 x 15mm  
16 x

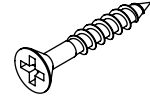

6. Screw M3.1 x 20 mm  
6 x

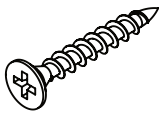

7. Screw M4 x 25mm  
7 x

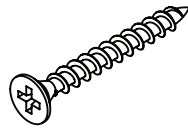

8. Screw M4 x 30mm  
3 x

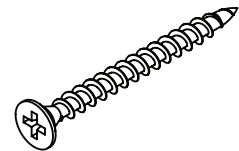

9. Screw M4 x 38mm  
12 x



10. Euro Screw M6 x 8mm  
12 x

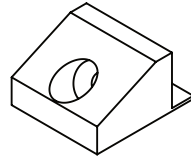

11. Backply Stopper  
6 x

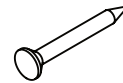

12. Nail Pin  
10 x



13. Nail Leg  
4 x



14. Screw M3 x 12mm  
6 x

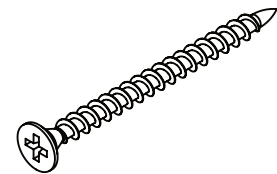

15. Screw M4 x 45mm  
3 x

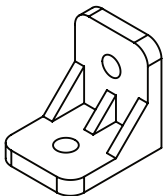

16. PVC L Bracket  
2 x

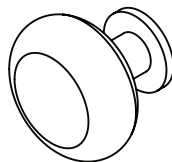

17. Handle  
3 x

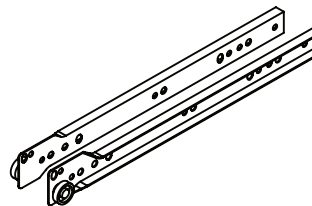

18. Drawer Slide 10"  
3 sets x

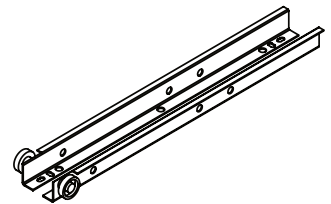

19. Drawer Slide 10"  
3 sets x

# HARDWARE

## FURNITURE TIPPING RESTRAINT

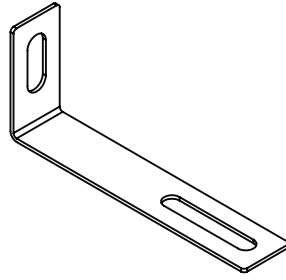
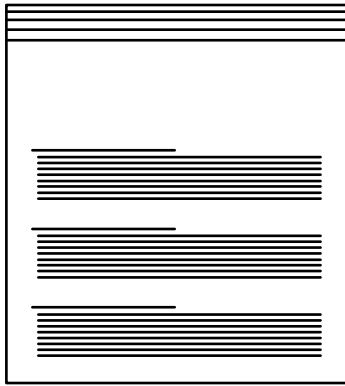

**20. Mounting L Bracket**  
2 x

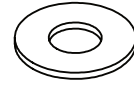

**21. Flat Washer M6 x 16mm**  
2 x

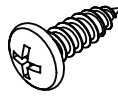

**22. Screw #10 x16mm**  
2 x

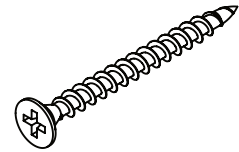

**23. Screw M4 x 38mm**  
2 x

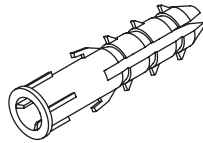

**24. Wall Plug**  
2 x

### TOOLS REQUIRED FOR ASSEMBLY (NOT INCLUDED)

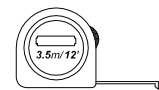
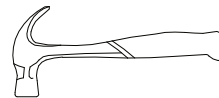
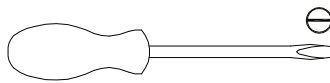
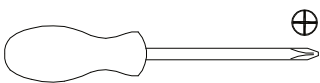

DO NOT USE POWER TOOLS TO ASSEMBLE THIS PRODUCT. USE OF POWER TOOLS WILL INVALIDATE ANY CLAIM AND MAY DAMAGE THIS PRODUCT MAKING IT UNSAFE.

NO USE HERRAMIENTAS ELÉCTRICAS PARA MONTAR ESTE PRODUCTO. EL USO DE LAS HERRAMIENTAS ELÉCTRICAS INVALIDARÁ CUALQUIER RECLAMO Y PUEDE DAÑAR ESTE PRODUCTO QUE LO PONE SEGURO.

N'UTILISEZ PAS D'OUTILS ÉLECTRIQUES POUR ASSEMBLER CE PRODUIT. L'UTILISATION DES OUTILS ÉLECTRIQUES ANNULERA TOUTE RÉCLAMATION ET PEUT ENDOMMAGER CE PRODUIT LE RENDANT SÉCURITAIRE.

# Assembly / Montaje / Assemblage

## STEP 1 / ETAPA 1 / ÉTAPE 1

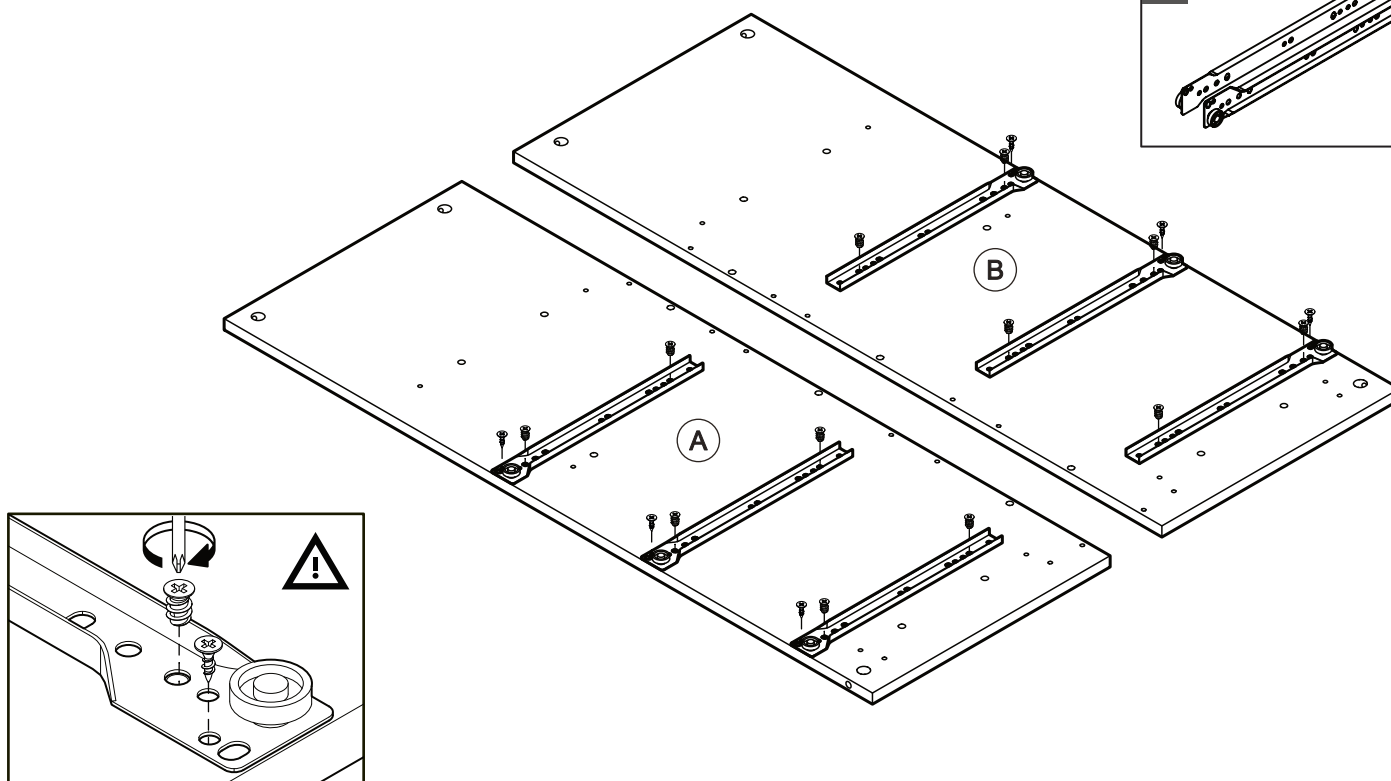
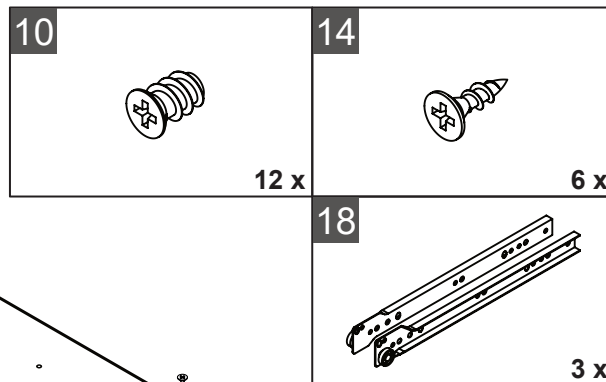

## STEP 2 / ETAPA 2 / ÉTAPE 2

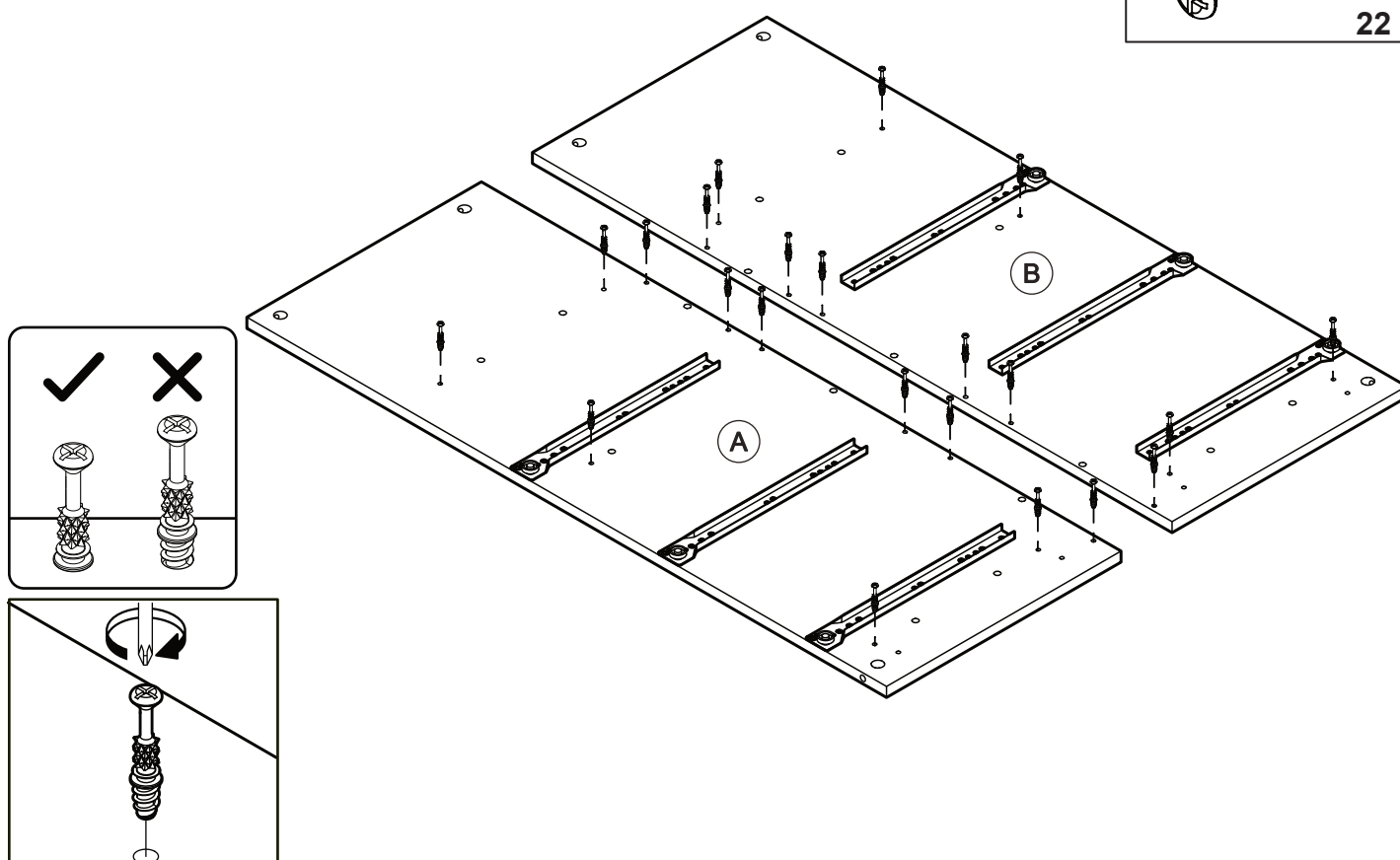
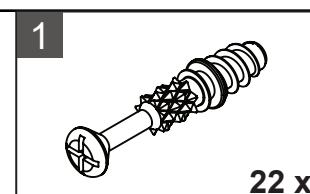

### STEP 3 / ETAPA 3 / ÉTAPE 3

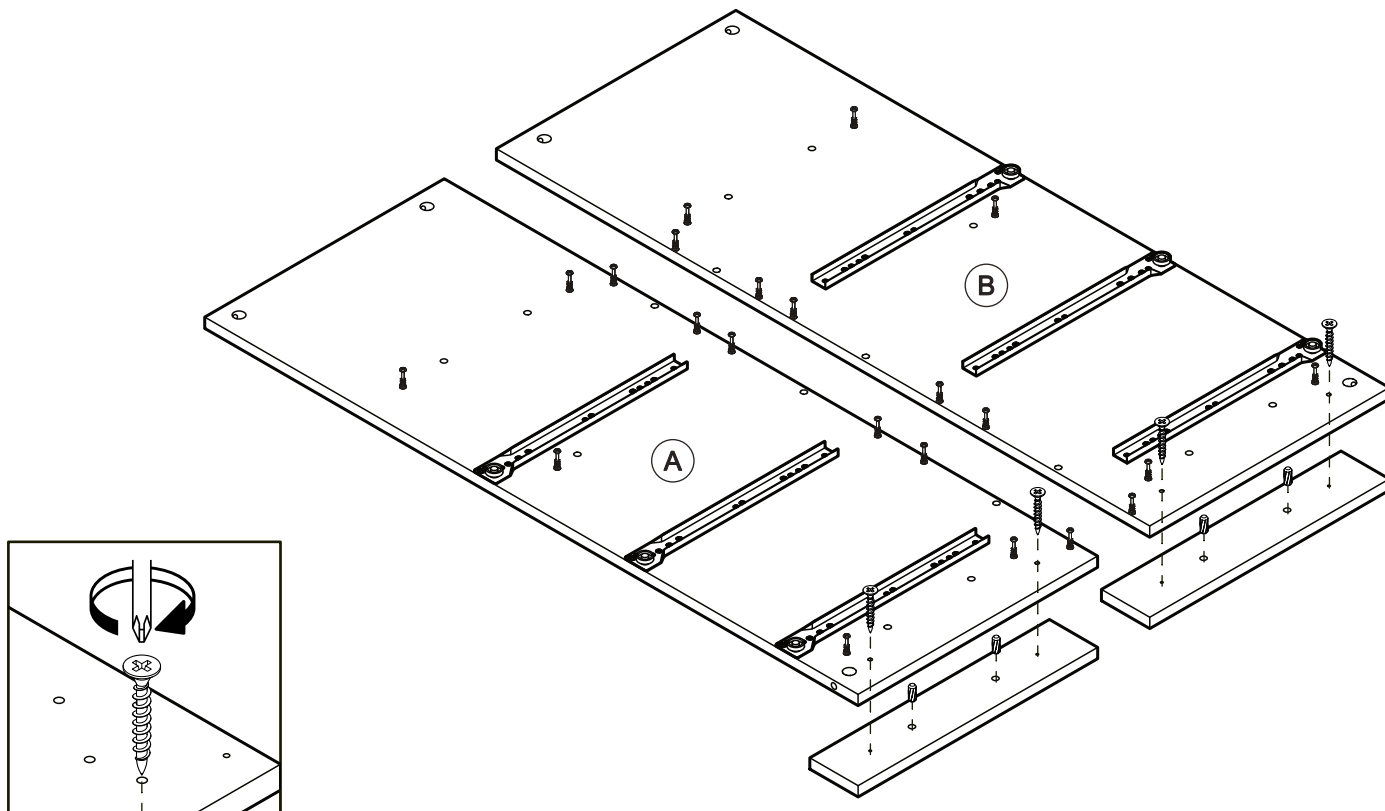
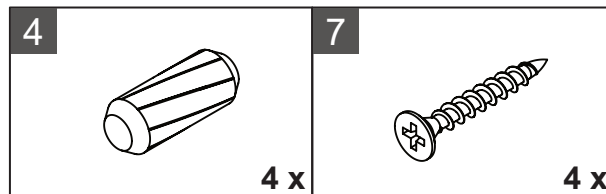

### STEP 4 / ETAPA 4 / ÉTAPE 4

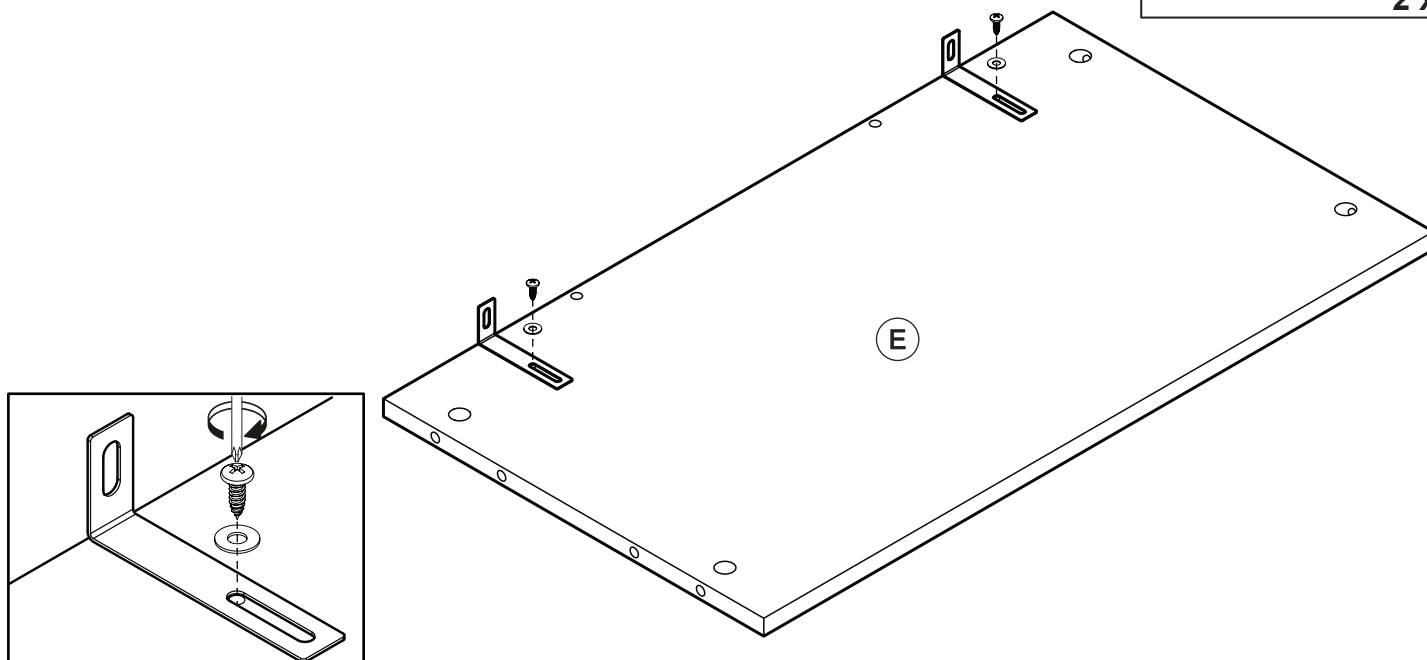
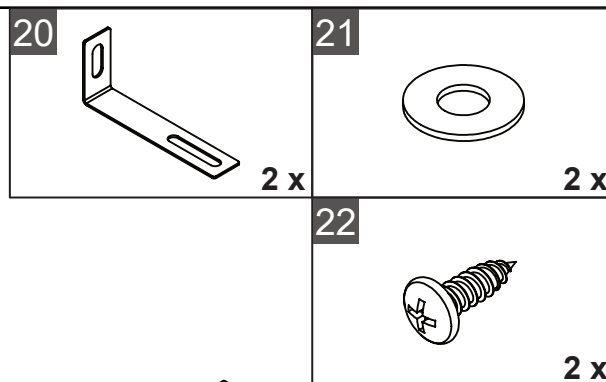



STEP 5 / ETAPA 5 / ÉTAPE 5

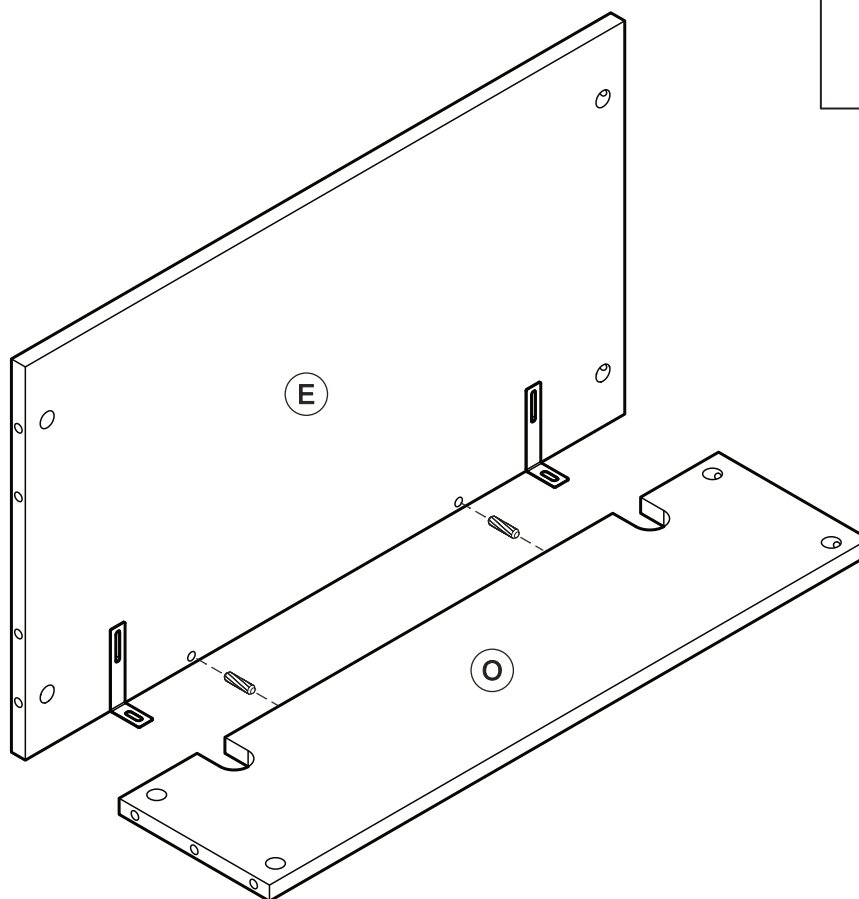
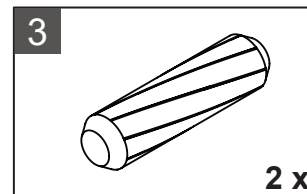

STEP 6 / ETAPA 6 / ÉTAPE 6

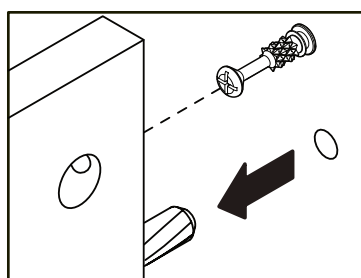
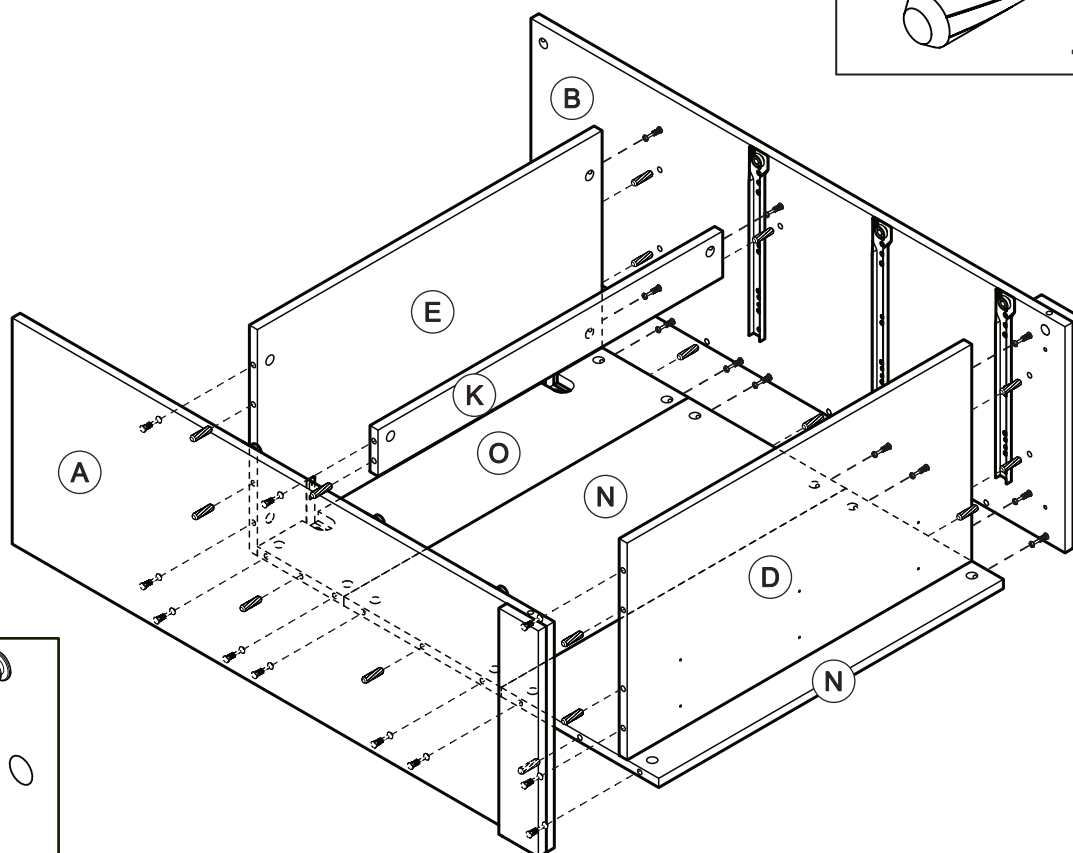
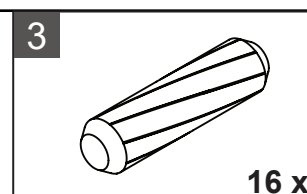

# STEP 7 / ETAPA 7 / ÉTAPE 7

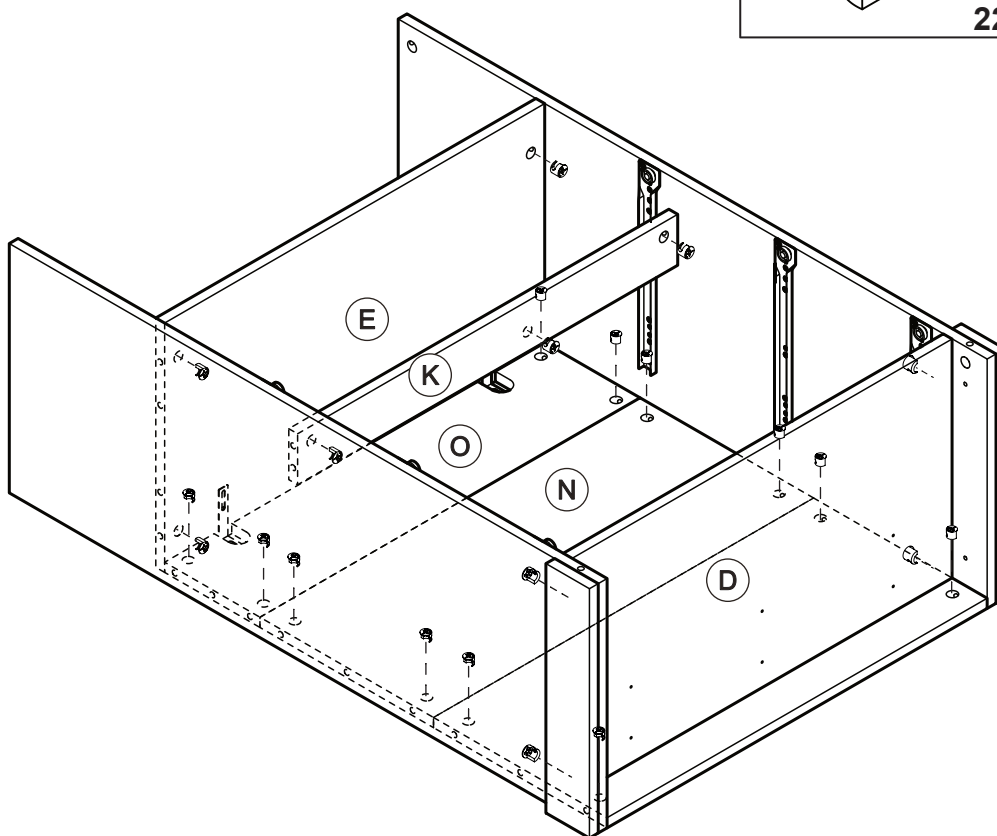
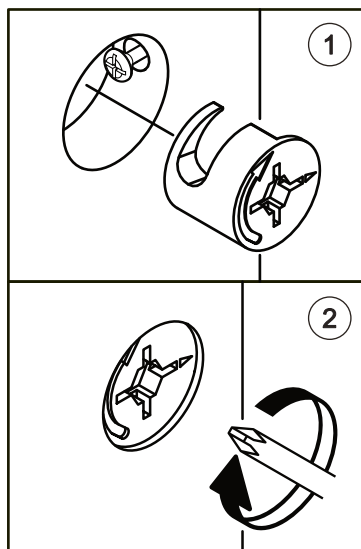
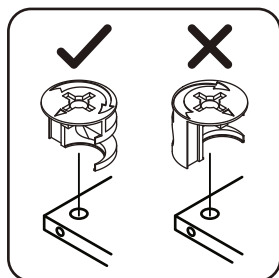
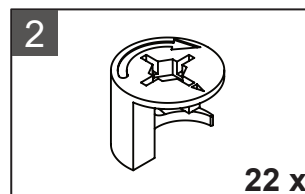

# STEP 8 / ETAPA 8 / ÉTAPE 8

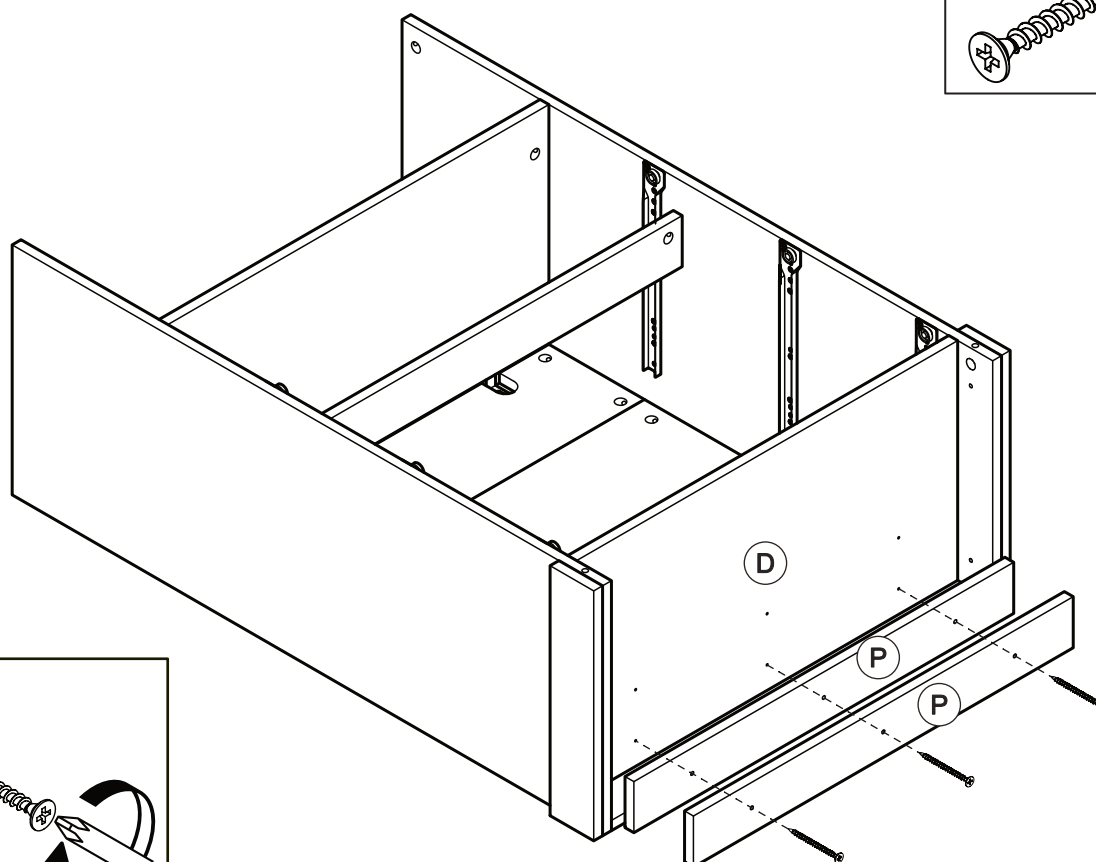
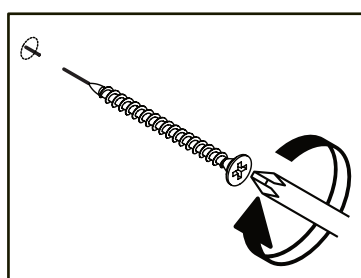
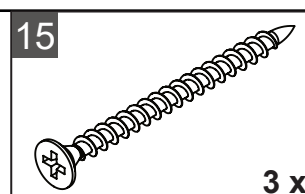

STEP 9 / ETAPA 9 / ÉTAPE 9

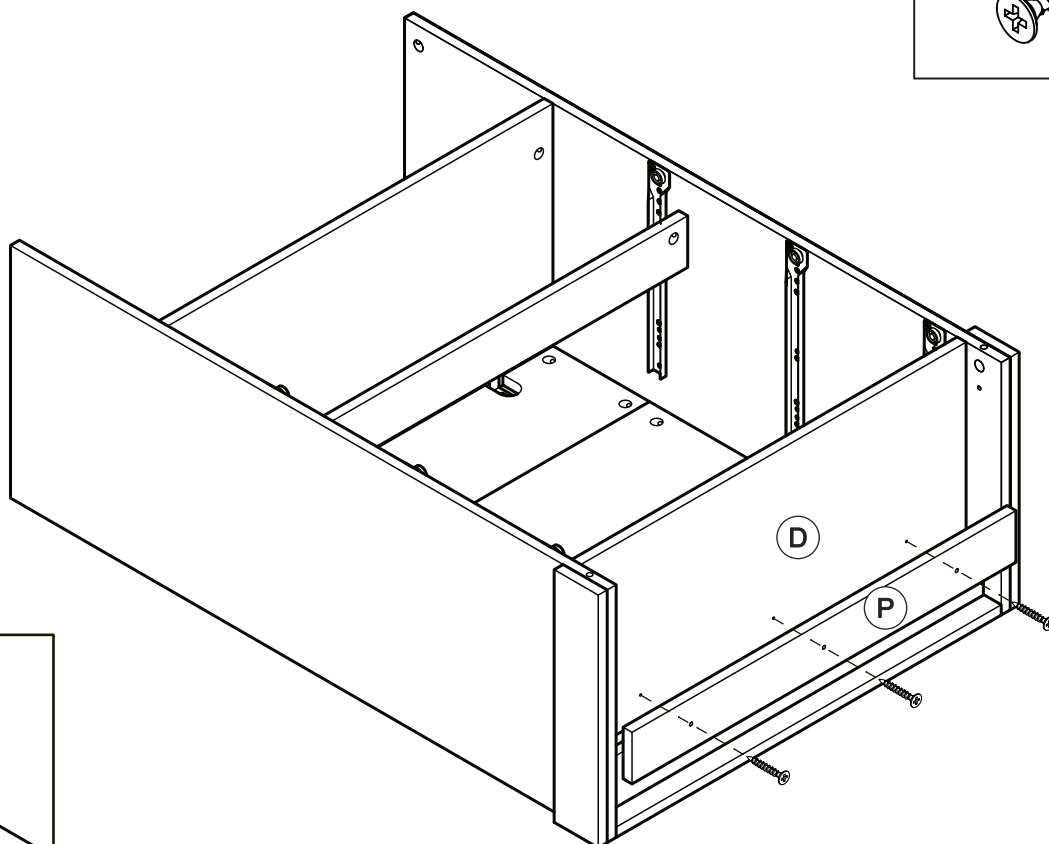
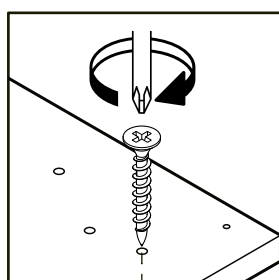
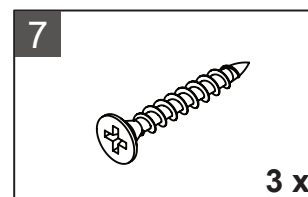

STEP 10 / ETAPA 10 / ÉTAPE 10

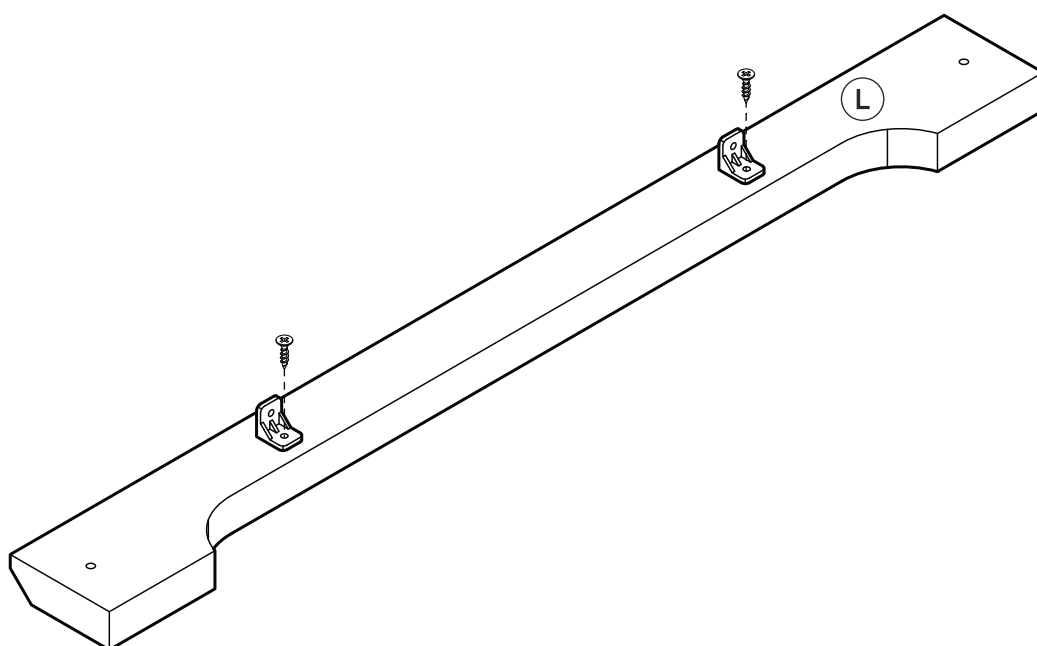
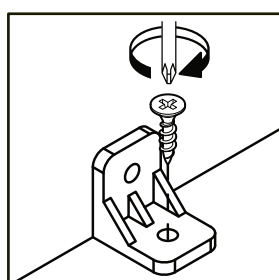
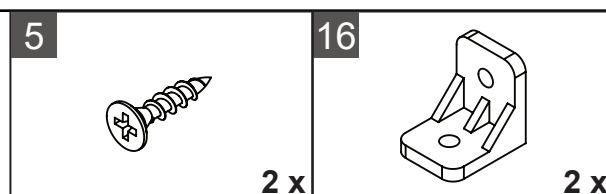

STEP 11 / ETAPA 11 / ÉTAPE 11

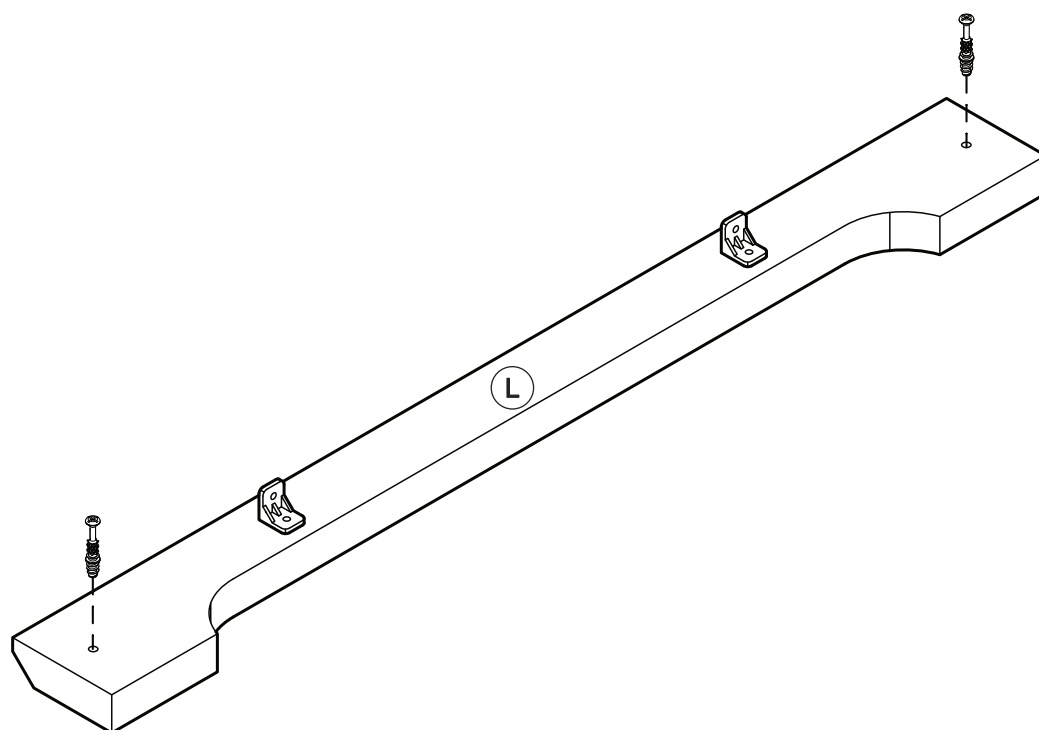
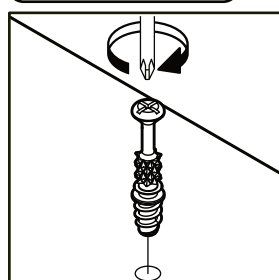
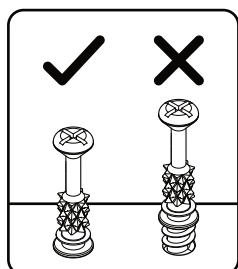
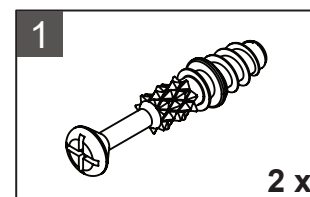

STEP 12 / ETAPA 12 / ÉTAPE 12

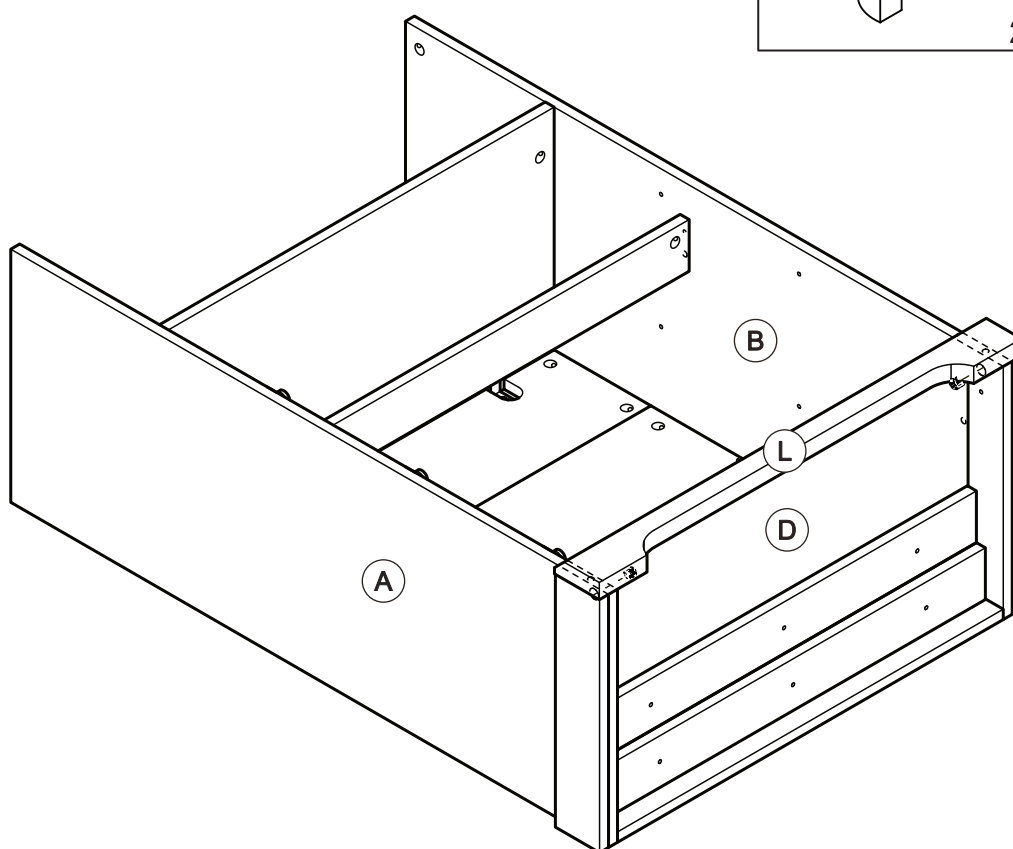
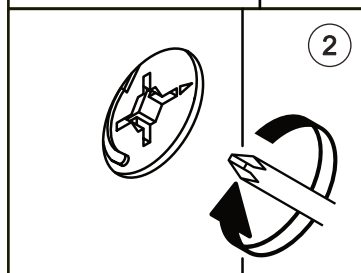
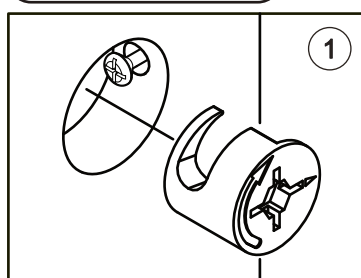
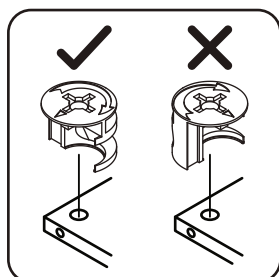
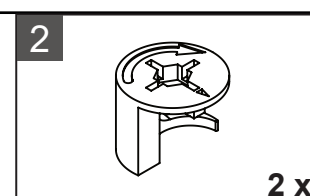

STEP 13 / ETAPA 13 / ÉTAPE 13

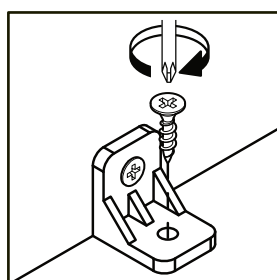
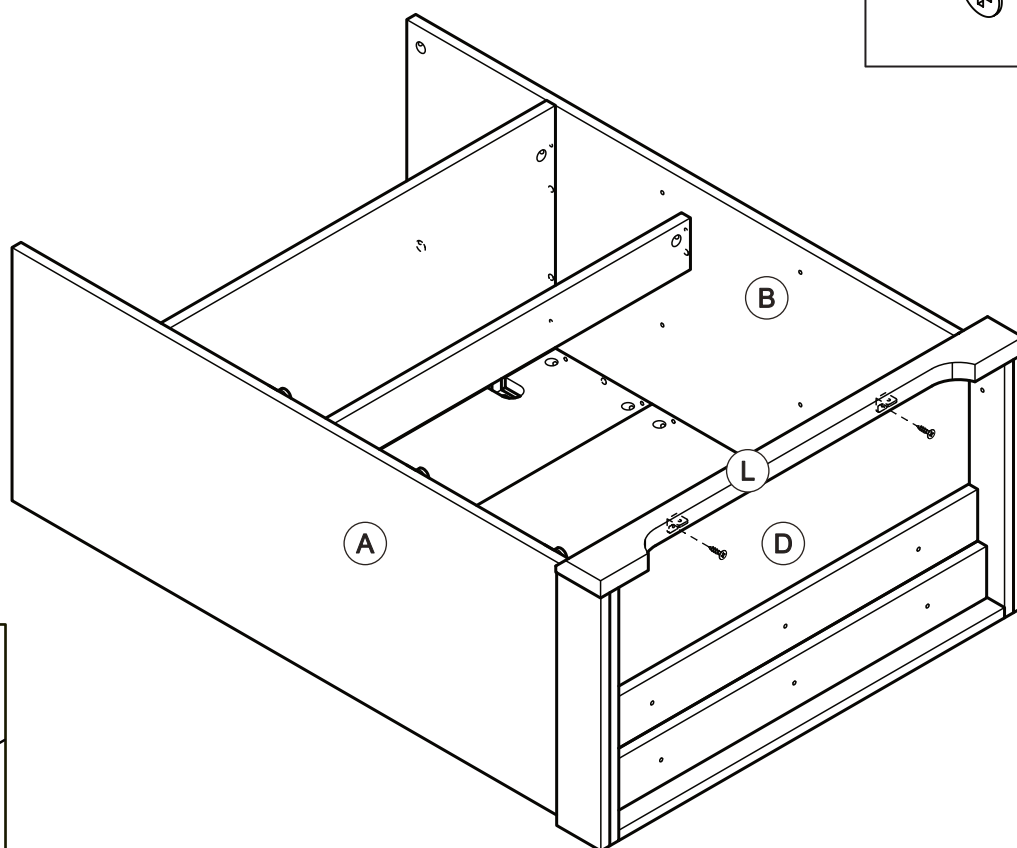
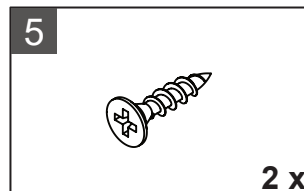

STEP 14 / ETAPA 14 / ÉTAPE 14

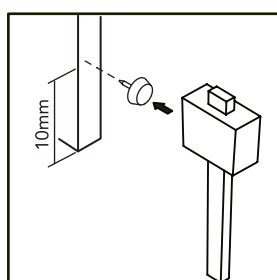
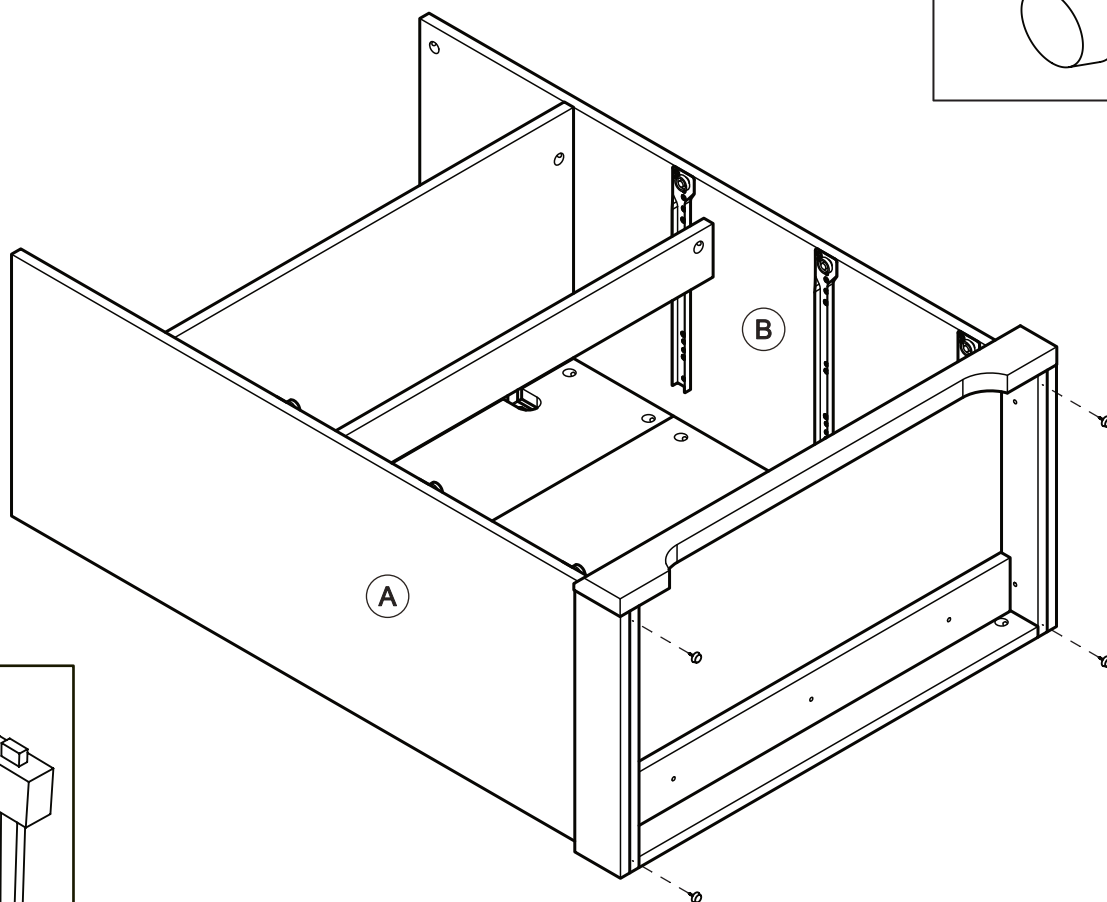
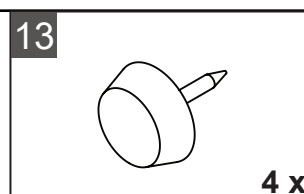

STEP 15 / ETAPA 15 / ÉTAPE 15

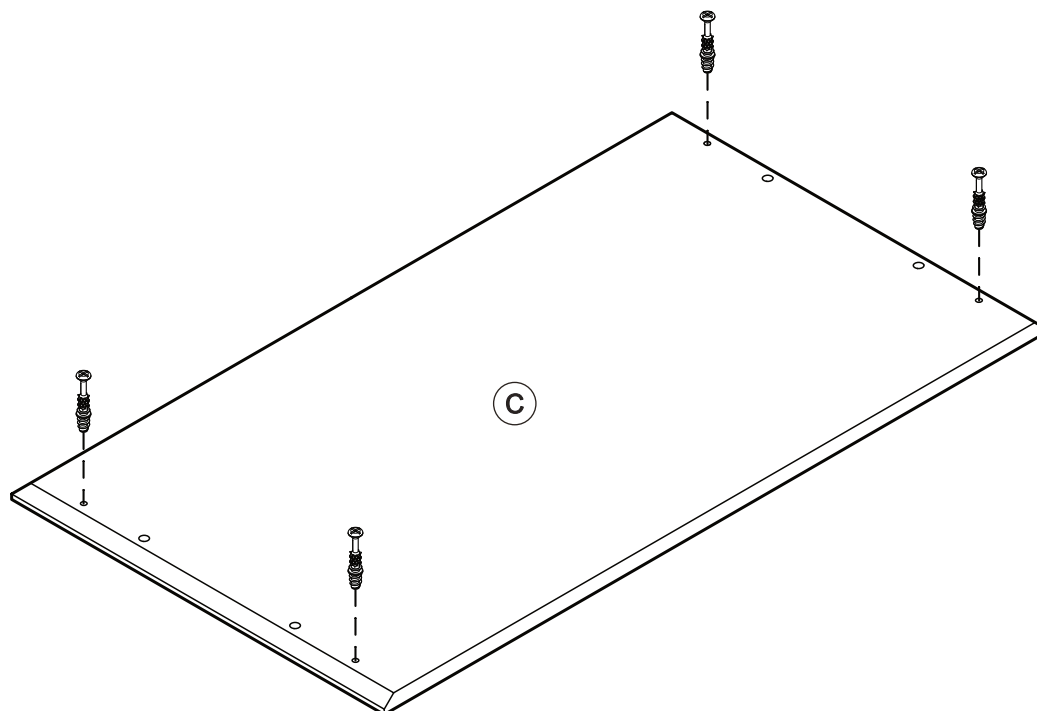
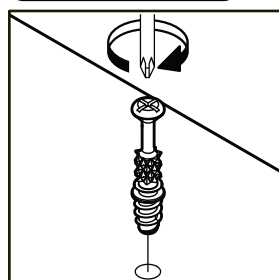
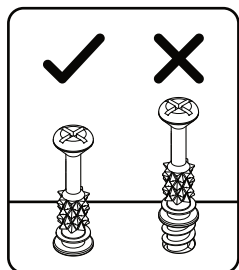
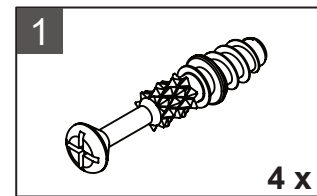

STEP 16 / ETAPA 16 / ÉTAPE 16

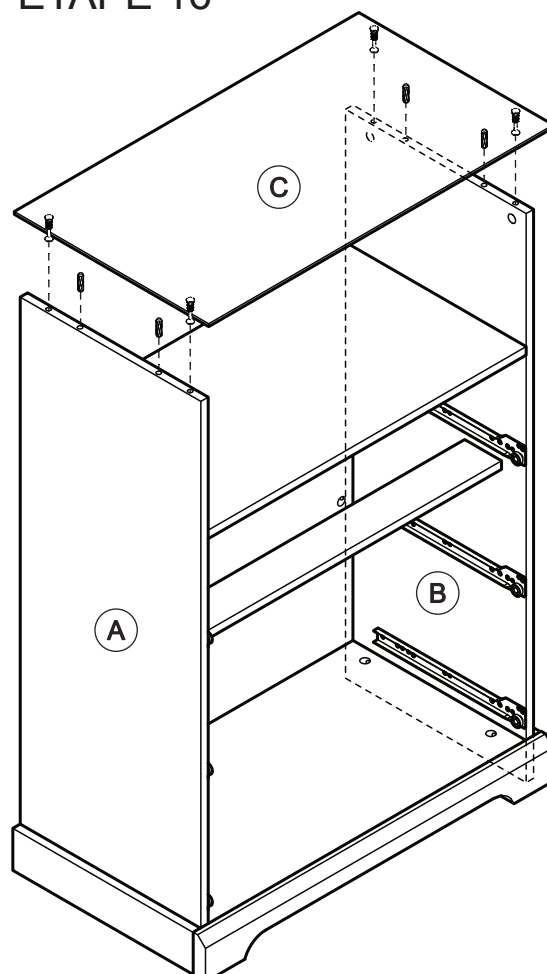
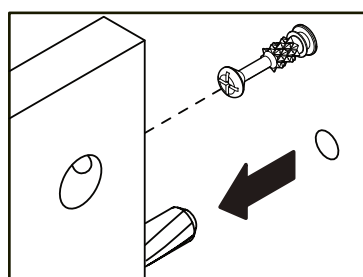
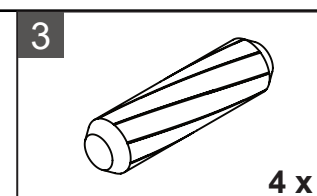

STEP 17 / ETAPA 17 / ÉTAPE 17

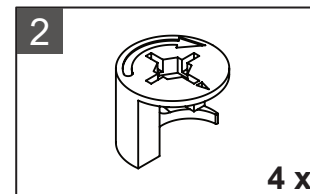
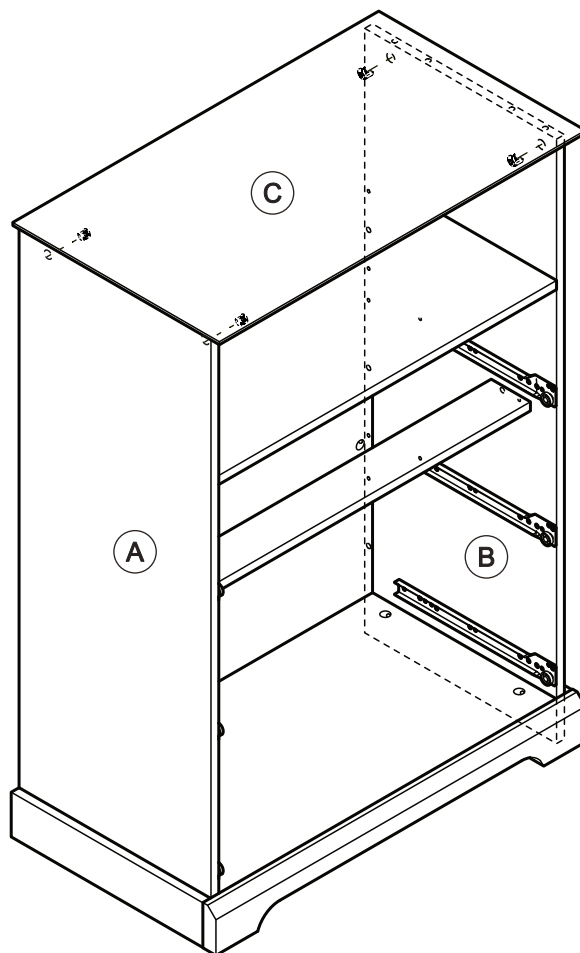
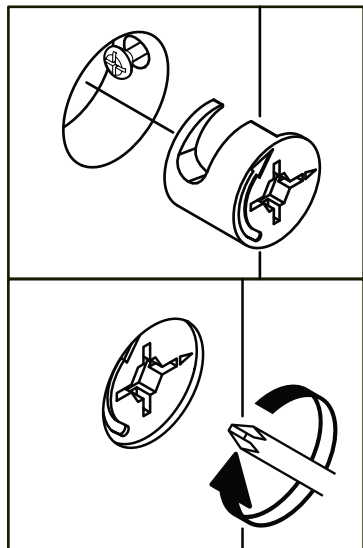
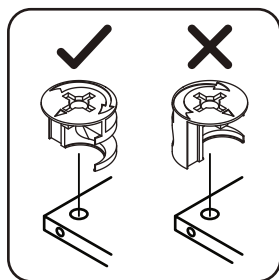

STEP 18 / ETAPA 18 / ÉTAPE 18

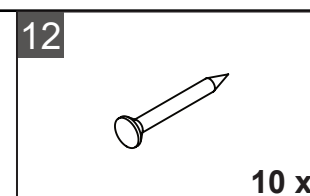
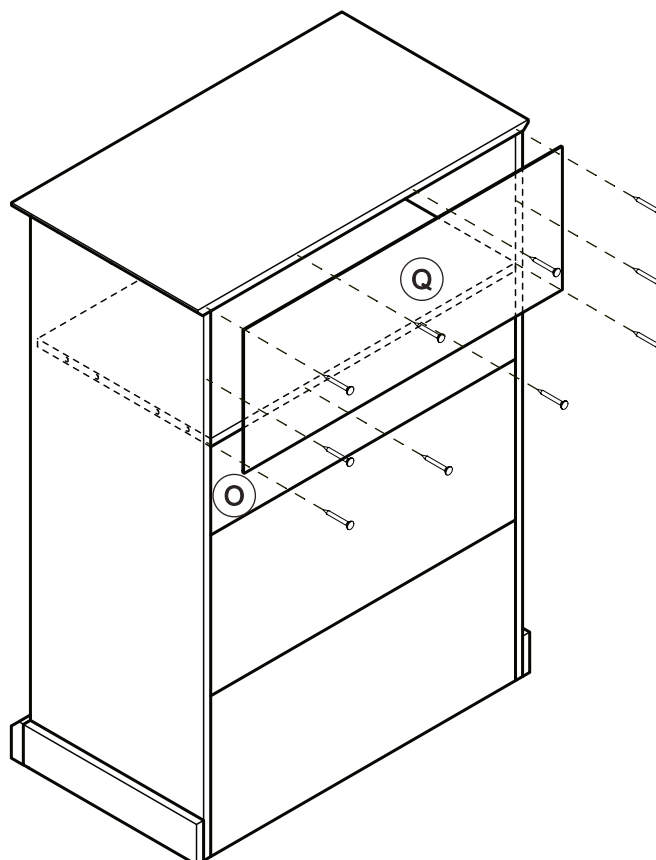
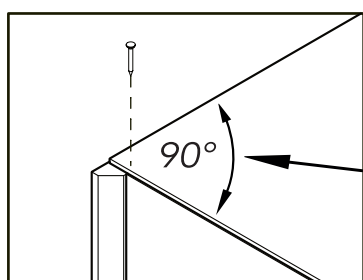

STEP 19 / ETAPA 19 / ÉTAPE 19

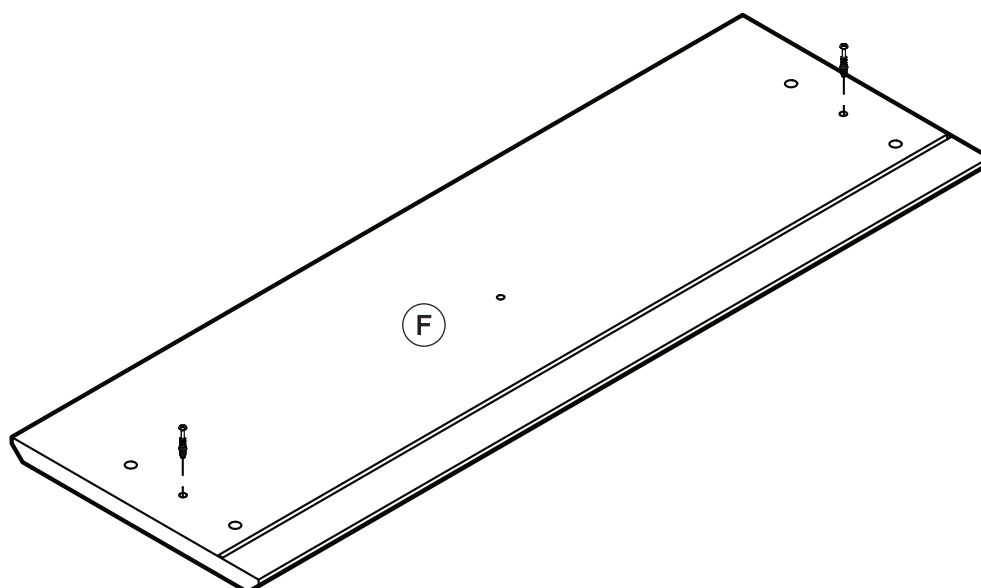
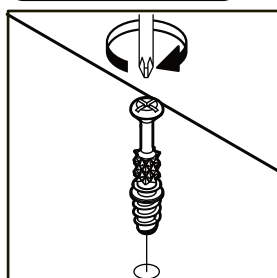
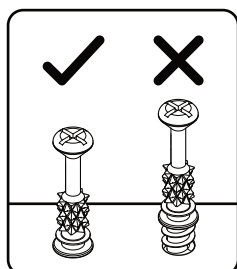
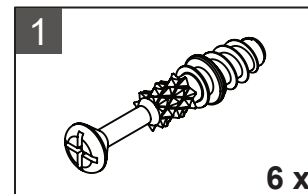

(3x)

STEP 20 / ETAPA 20 / ÉTAPE 20

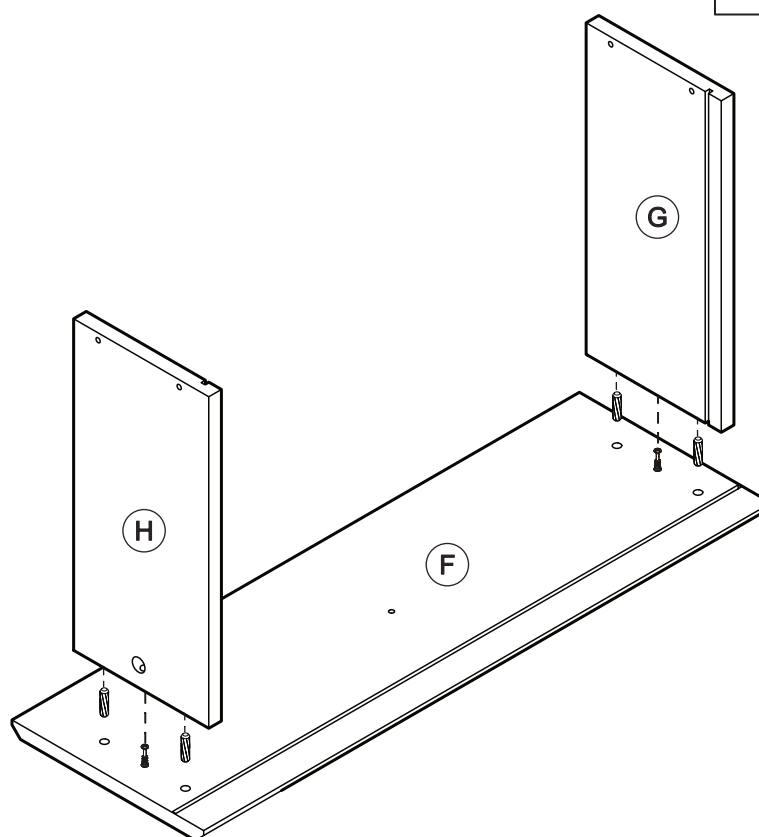
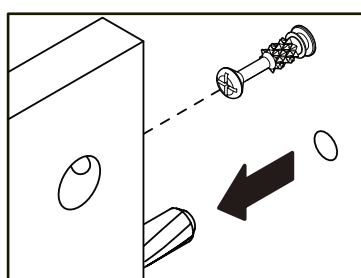
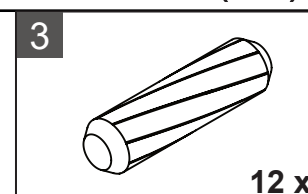

(3x)



STEP 21 / ETAPA 21 / ÉTAPE 21

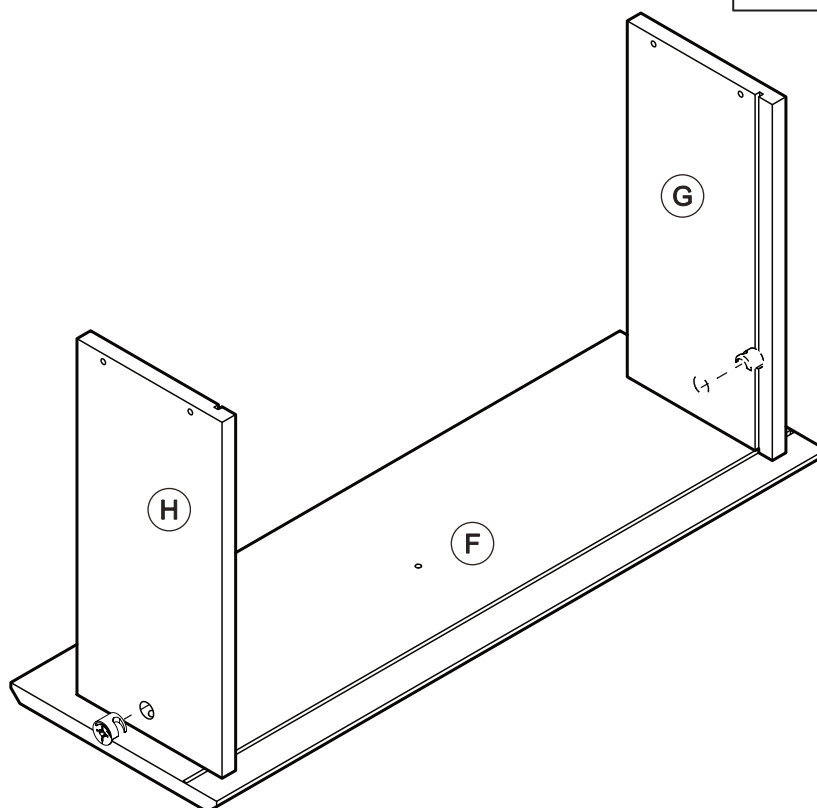
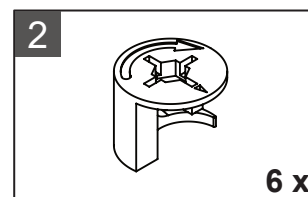
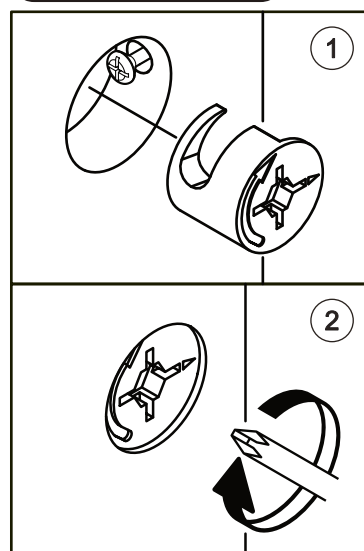
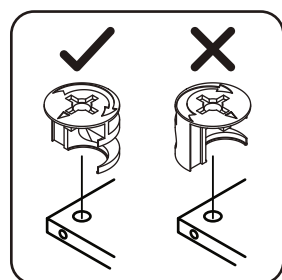

(3x)

STEP 22 / ETAPA 22 / ÉTAPE 22

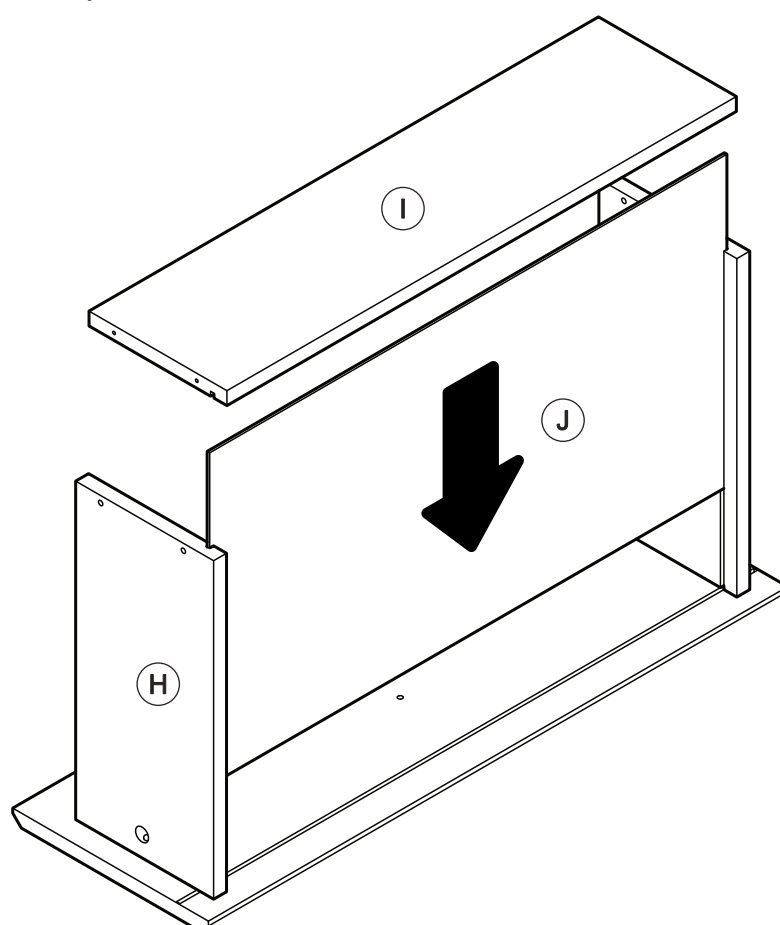

(3x)

STEP 23 / ETAPA 23 / ÉTAPE 23

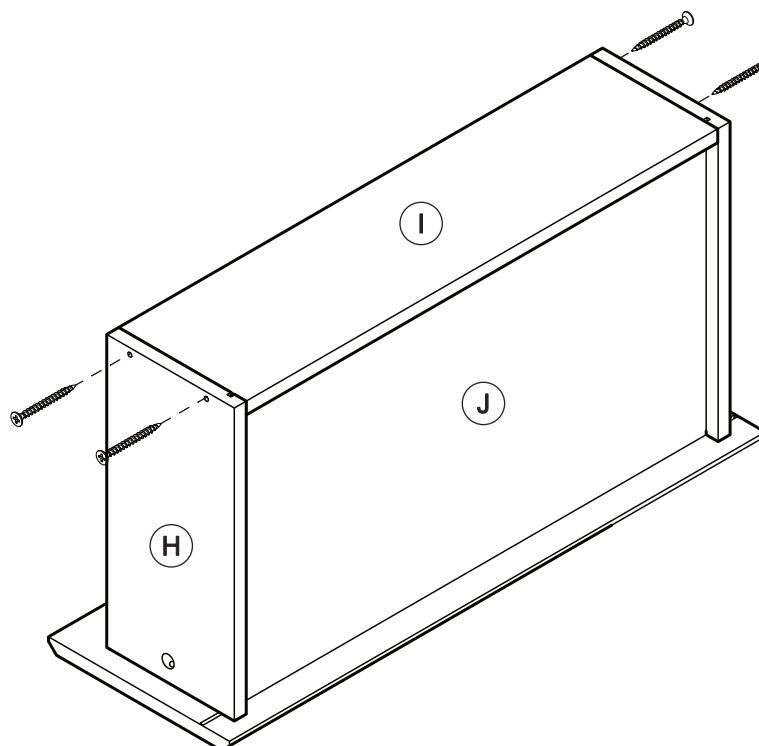
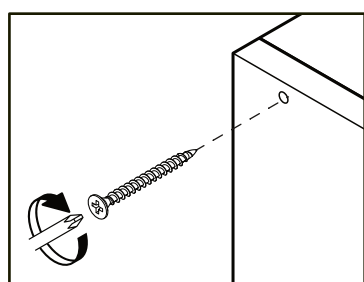
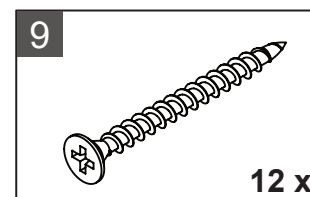

(3x)

STEP 24 / ETAPA 24 / ÉTAPE 24

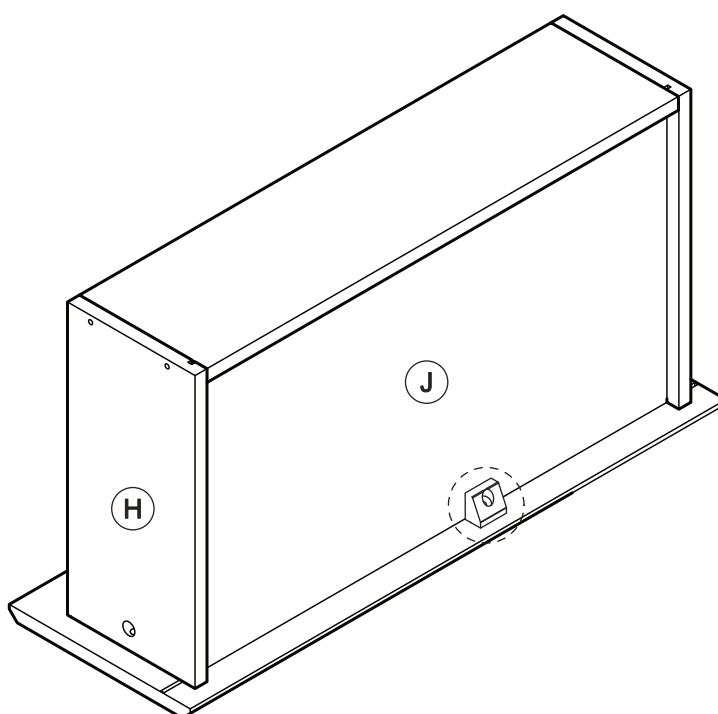
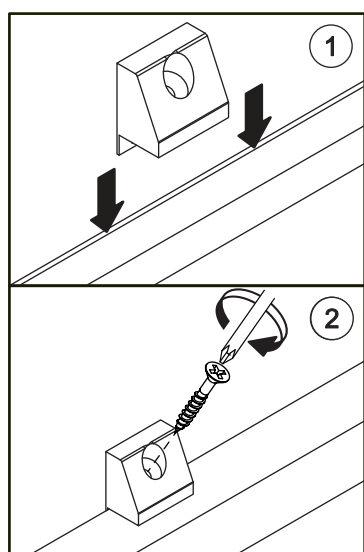
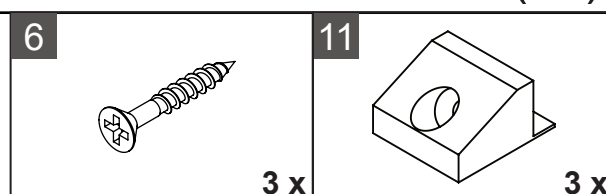

(3x)

STEP 25 / ETAPA 25 / ÉTAPE 25

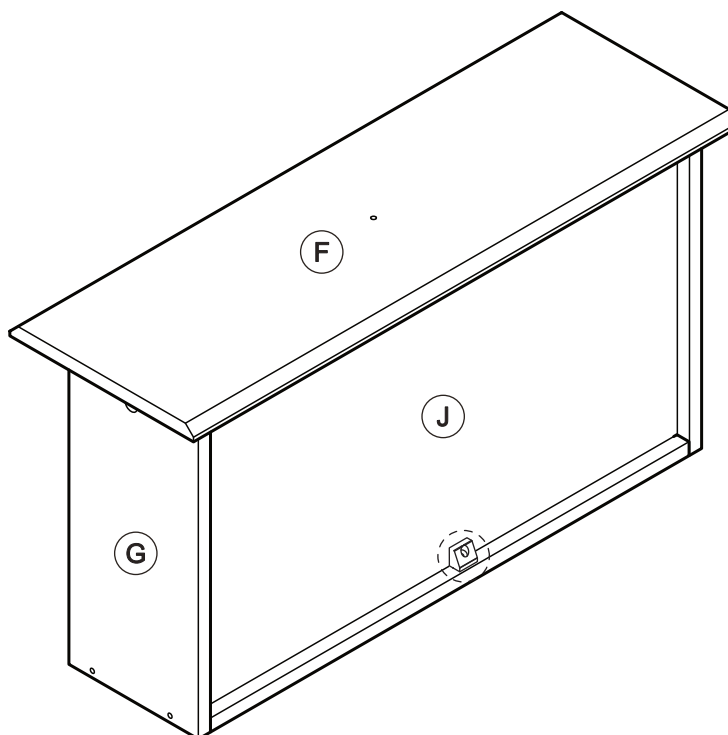
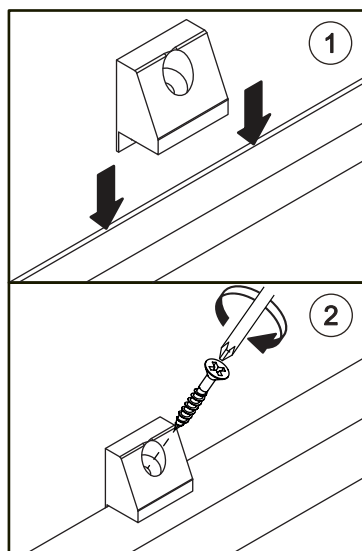
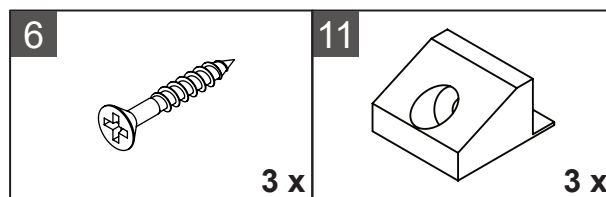

(3x)

STEP 26 / ETAPA 26 / ÉTAPE 26

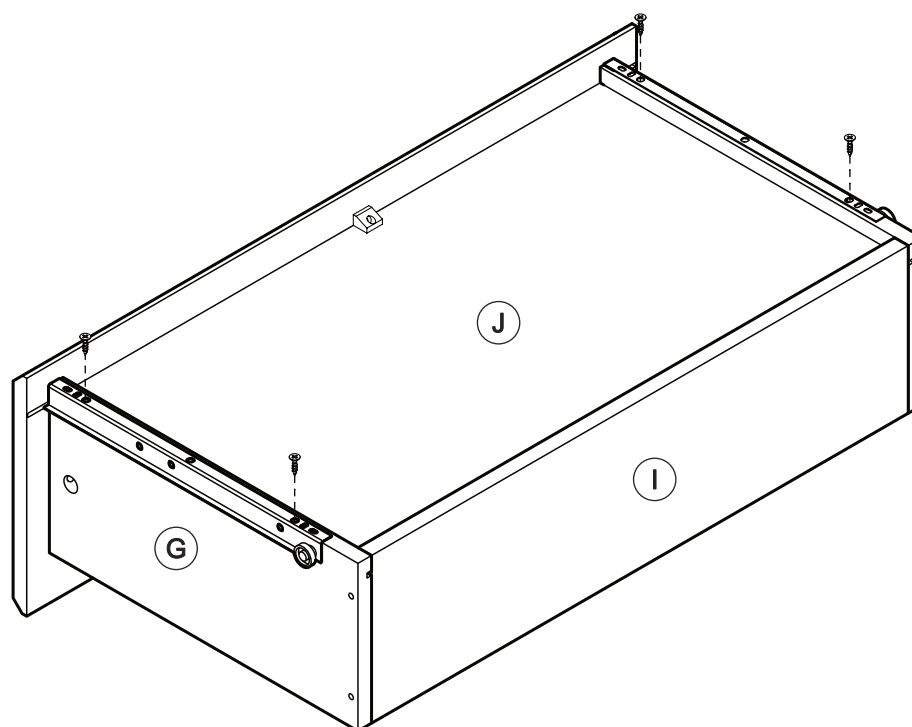
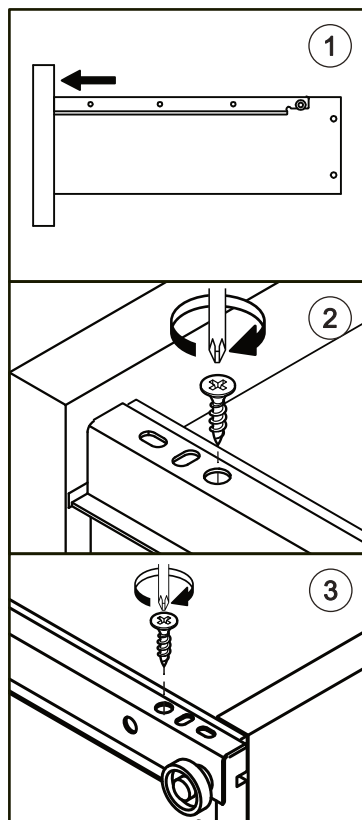
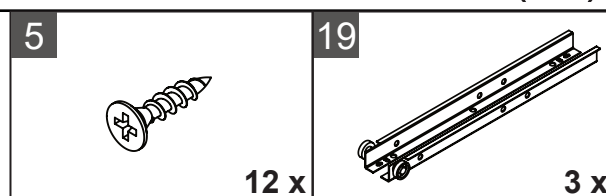

(3x)

STEP 27 / ETAPA 27 / ÉTAPE 27

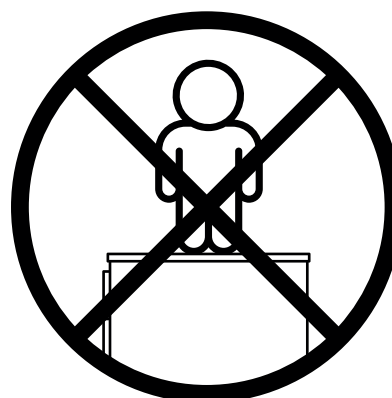
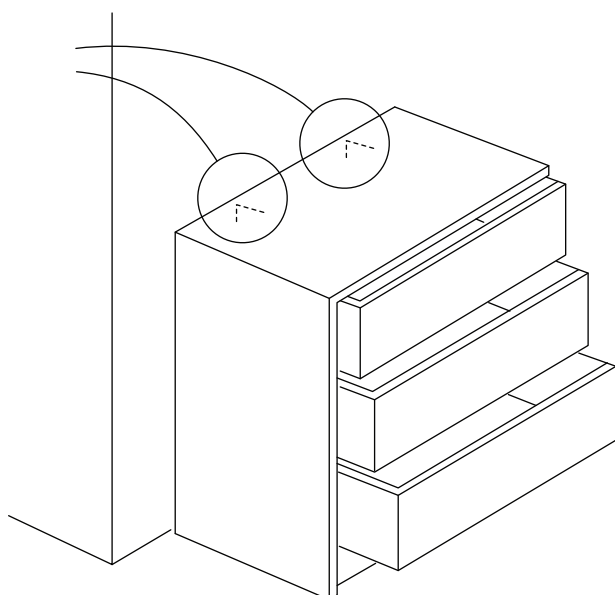
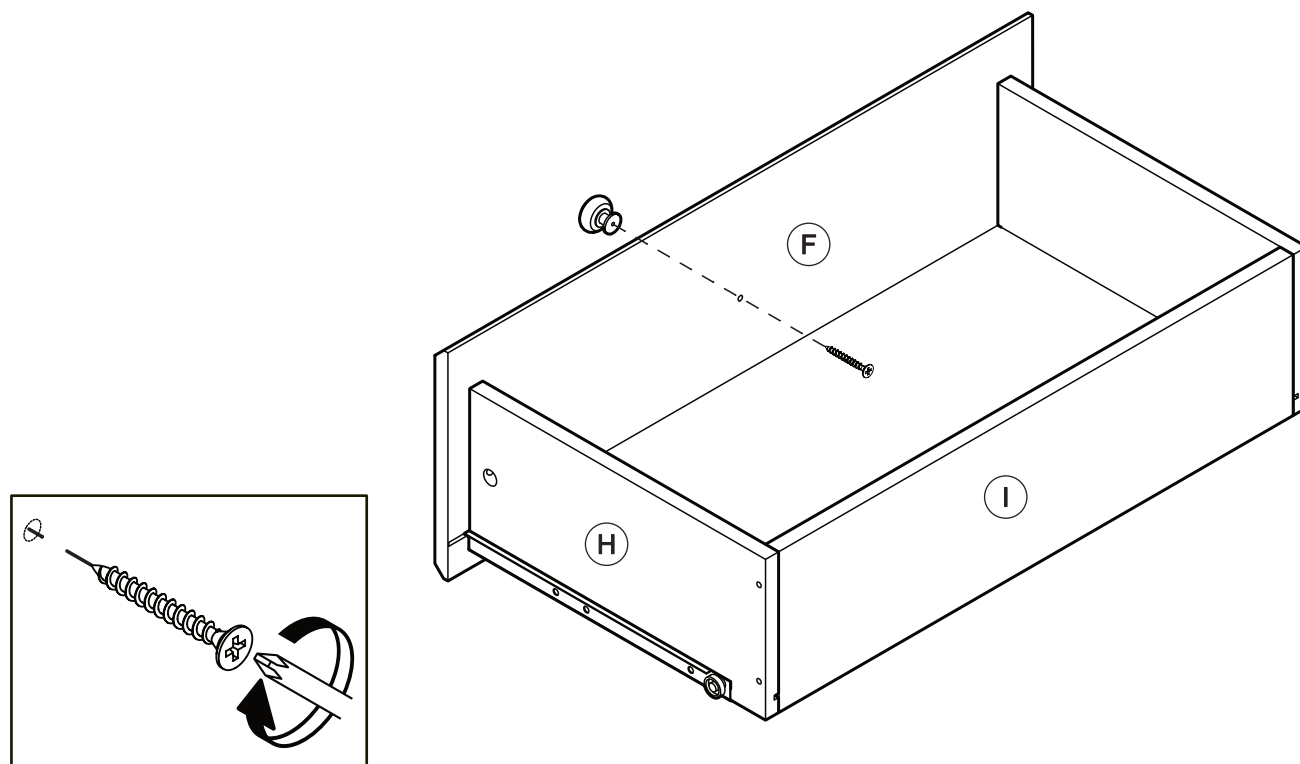
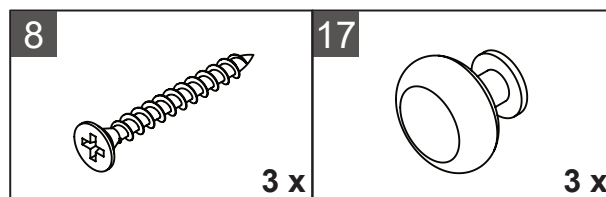

**IMPORTANT: THIS UNIT MUST BE SECURE TO THE WALL TO HELP PREVENT TIPOVER. FOLLOW THESE INSTRUCTIONS TO INSTALL THE ANTI-TIPPING SAFETY BRACKET PROVIDED WITH THIS PRODUCT.**

**IMPORTANTE: ESTA UNIDAD DEBE ESTAR SEGURA A LA PARED PARA AYUDAR A PREVENIR EL TIPOVER. SIGA ESTAS INSTRUCCIONES PARA INSTALAR EL SOPORTE DE SEGURIDAD ANTI-TIPPING PROPORCIONADO CON ESTE PRODUCTO.**

**IMPORTANT : CETTE UNITÉ DOIT ÊTRE SÉCURITAIRE JUSQU'AU MUR POUR AIDER À PRÉVENIR LA BASCULEMENT. SUIVEZ CES INSTRUCTIONS POUR INSTALLER LE SUPPORT DE SÉCURITÉ ANTI-BASCULEMENT FOURNI AVEC CE PRODUIT.**

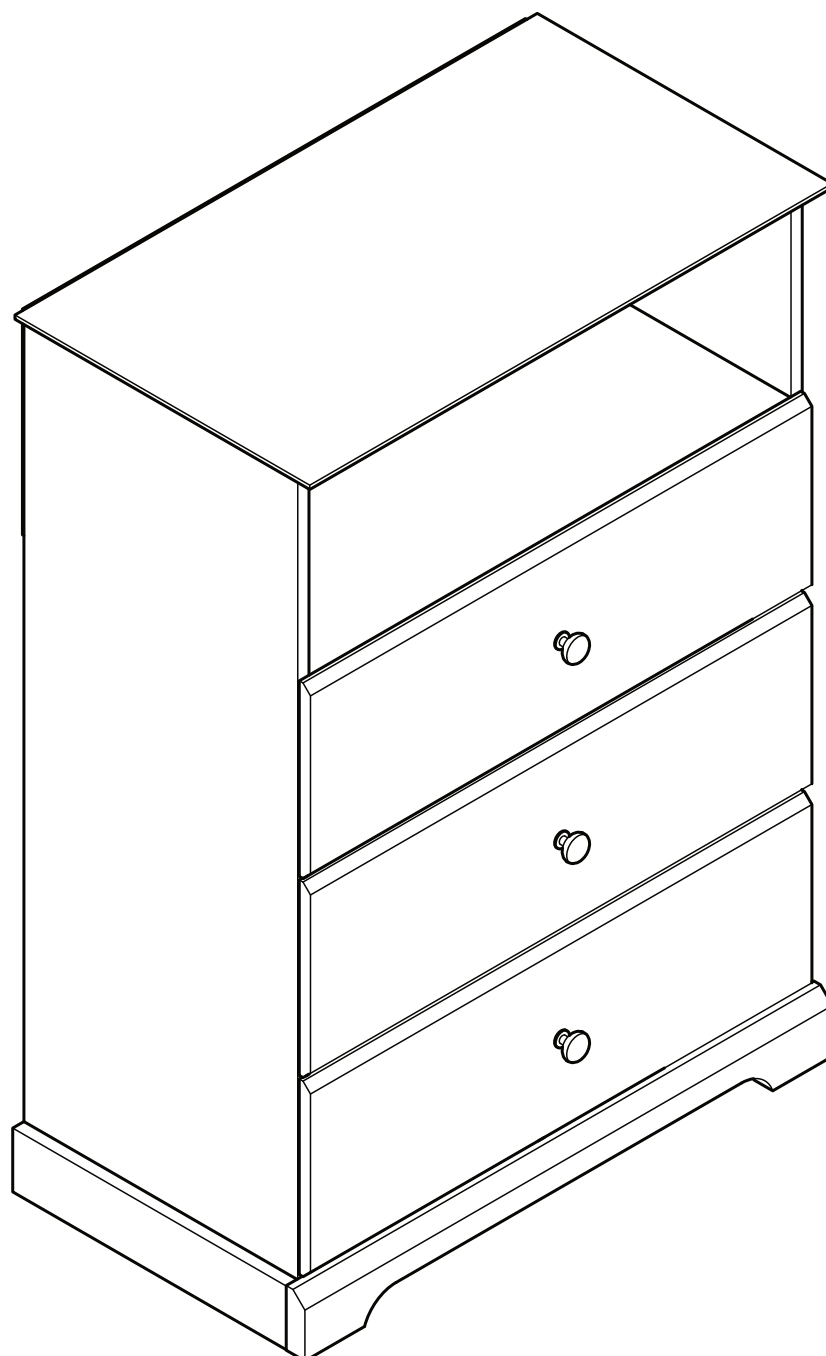

## STEP 28 / ETAPA 28 / ÉTAPE 28

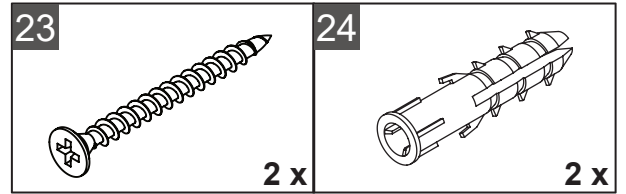
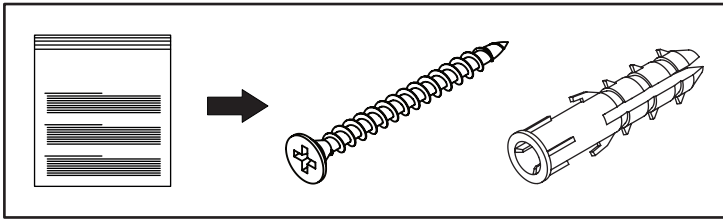

**Drywall anchor that supplied with this product is general purpose wall plug only.**

Consult your local hardware store for appropriate anchors for the type of wall you intend to securely attach the safety bracket.

**Ancla de paneles de yeso que se suministra con este producto es enchufe de pared de propósito general solamente.**

Consulte a su ferretería local para obtener los anclajes adecuados para el tipo de muro que desea fijar el soporte de seguridad.

**Ancre de cloison sèche qui a fourni avec ce produit est prise de mur d'usage général seulement.**

Consultez votre quincaillerie locale pour trouver des ancrs appropriées pour le type de mur que vous avez l'intention de attacher le support de sécurité.

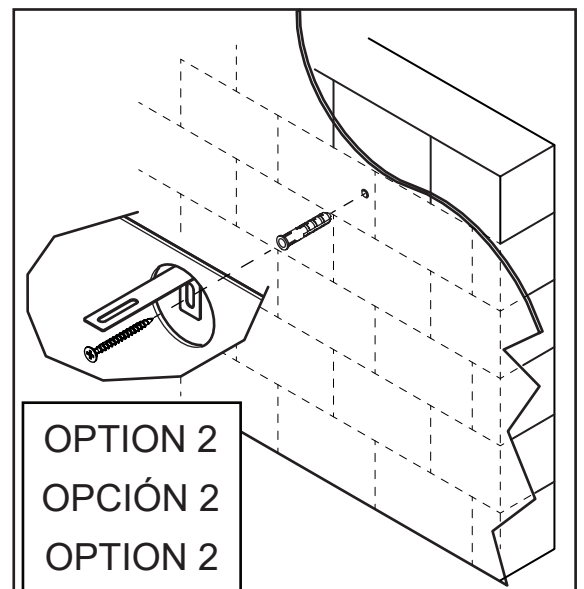
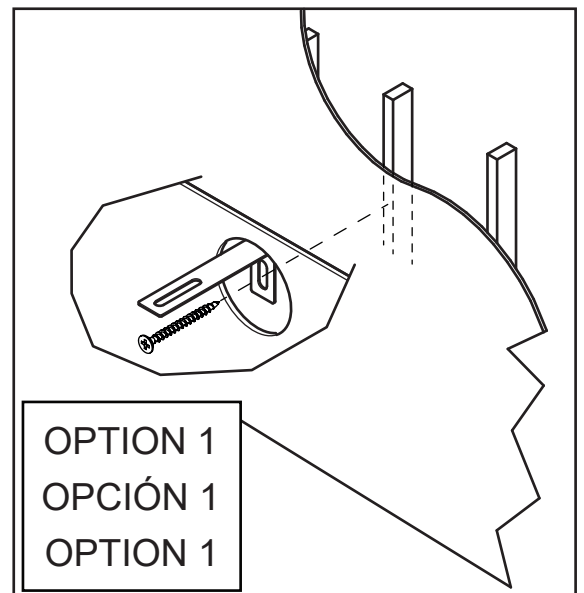
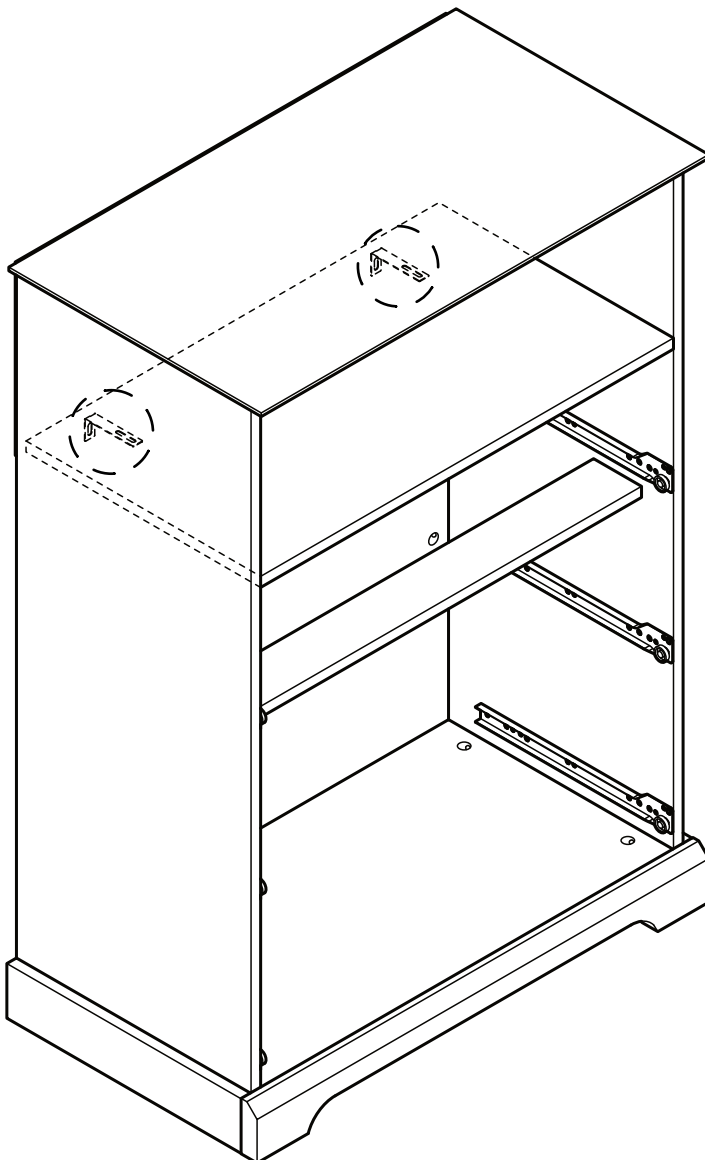

### **OPTION 1: Attachment into a wall stud (preferred method)**

Using a stud finder, locate a stud in the wall. Place your unit against the wall, with the safety bracket aligned in this location. To make driving the screw easier, you can drill a 3mm diameter pilot hole through the safety bracket into the stud. Drive the screw through the safety bracket into the wall stud. Tighten the screw that was not fully tightened in step 9.

### **OPTION 2: Attachment into masonry**

Locate your unit where desired against a wall and mark the wall through the safety bracket, then move your unit aside. Drill a 6mm diameter hole into the wall. Tap the wall anchor into the hole until it is flush. Move your unit into location and fasten the wall bracket to the wall anchor with the screw. Tighten the screw that was not fully tightened in step 9.

### **OPCION 1: Adjunto en un perno de pared (método preferido)**

Con un buscador de pernos, localice un perno en la pared. Coloque la unidad contra la pared, con el soporte de seguridad alineado en esta ubicación. Para facilitar la conducción del tornillo, puede perforar un orificio piloto de 3 mm de diámetro a través del soporte de seguridad en el perno. Conduzca el tornillo a través del soporte de seguridad en el perno de pared. Apriete el tornillo que no estaba completamente apretado en el paso 9

### **OPCION 2: Fijación en la albañilería**

Localice su unidad donde desee contra una pared y marque la pared a través del soporte de seguridad, luego a un lado su unidad. Taladre un orificio de 6 mm de diámetro en la pared. Toque el ancla de la pared en el agujero hasta que está al ras. Mueva la unidad a la ubicación y fije el soporte de pared al anclaje de pared con el tornillo. Apriete el tornillo que no estaba completamente apretado en el paso 9.

### **OPTION 1 : Fixation dans un goujon de mur (méthode préférée)**

À l'aide d'un stud finder, localisez un goujon dans le mur. Placez votre appareil contre le mur, avec le support de sécurité alignés à cet endroit. Pour faciliter la conduite de la vis, vous pouvez percer un trou pilote de 3 mm de diamètre à travers le support de sécurité dans le goujon. Conduisez la vis à travers le support de sécurité dans le goujon du mur. Serrez la vis qui n'a pas été entièrement serrée à l'étape 9.

### **OPTION 2 : Fixation en maçonnerie**

Localisez votre appareil lorsque vous le souhaitez contre un mur et marquez le mur à travers le support de sécurité, puis déplacez votre unité de côté. Percez un trou de 6 mm de diamètre dans le mur. Appuyez sur l'ancre murale dans le trou jusqu'à ce qu'il est flush. Déplacez votre unité dans l'emplacement et attachez le support de mur à l'ancre de mur avec la vis. Serrez la vis qui n'a pas été entièrement serrée à l'étape 9.

## STEP 29 / ETAPA 29 / ÉTAPE 29

Put the Drawer that has a fixed anti tip warning label in the top drawer position

Coloque el cajón que tiene una etiqueta de advertencia anti punta fija en la posición superior del cajón

Placez le tiroir qui a une étiquette d'avertissement anti-pointe afixé dans la position du tiroir supérieur

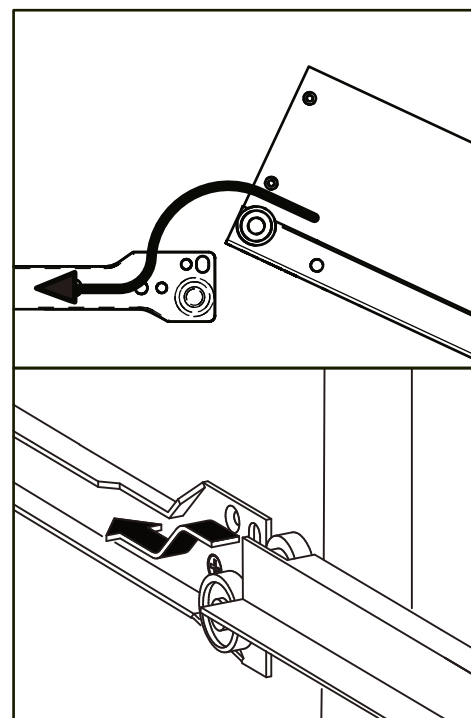
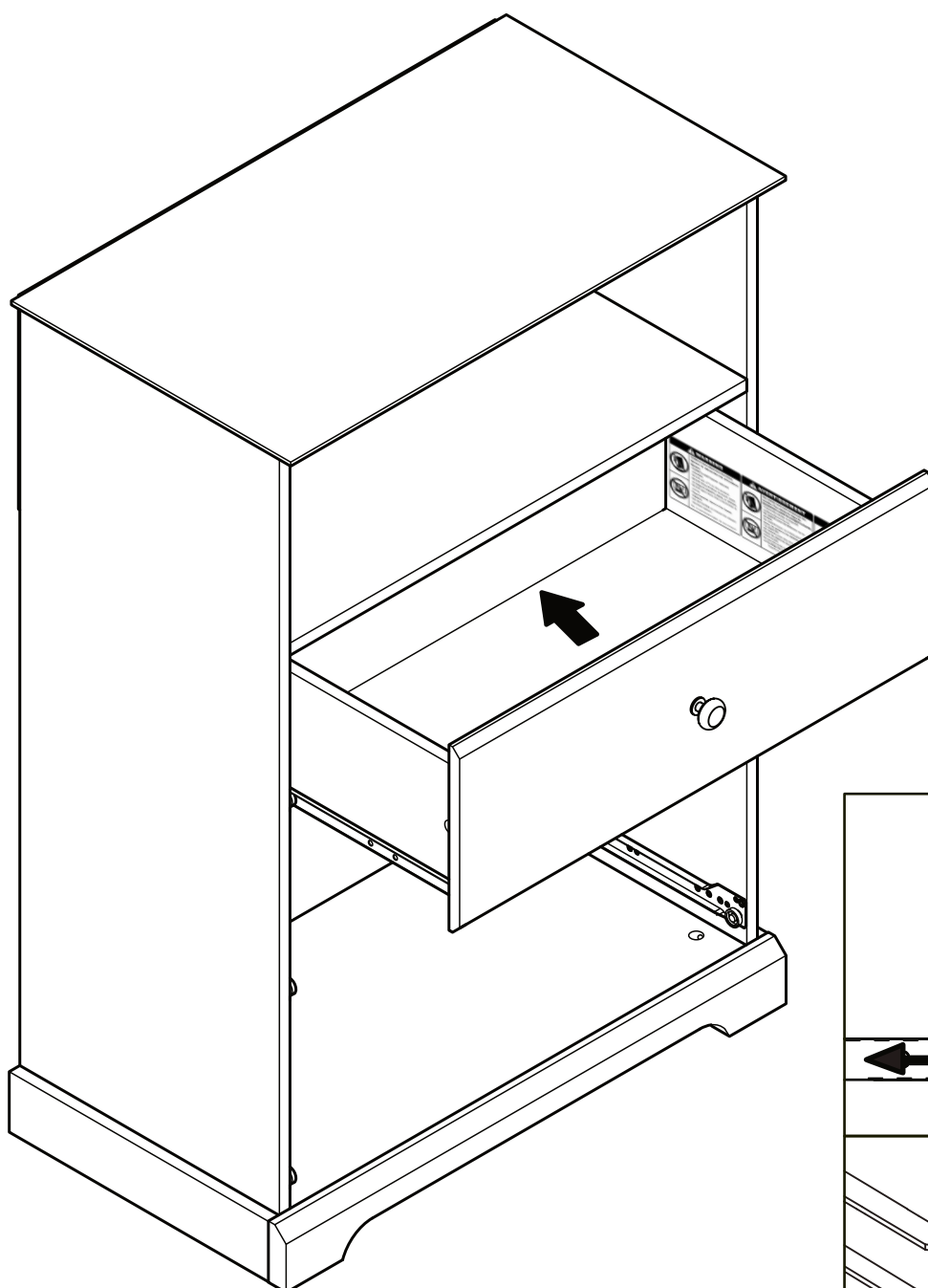
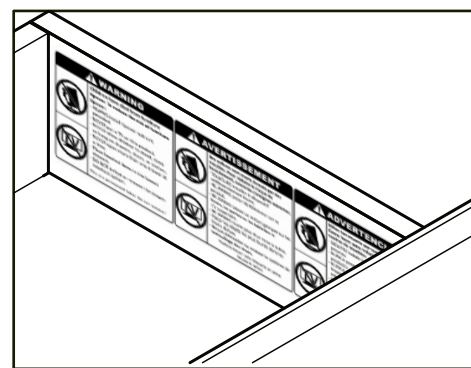



## STEP 30 / ETAPA 30 / ÉTAPE 30

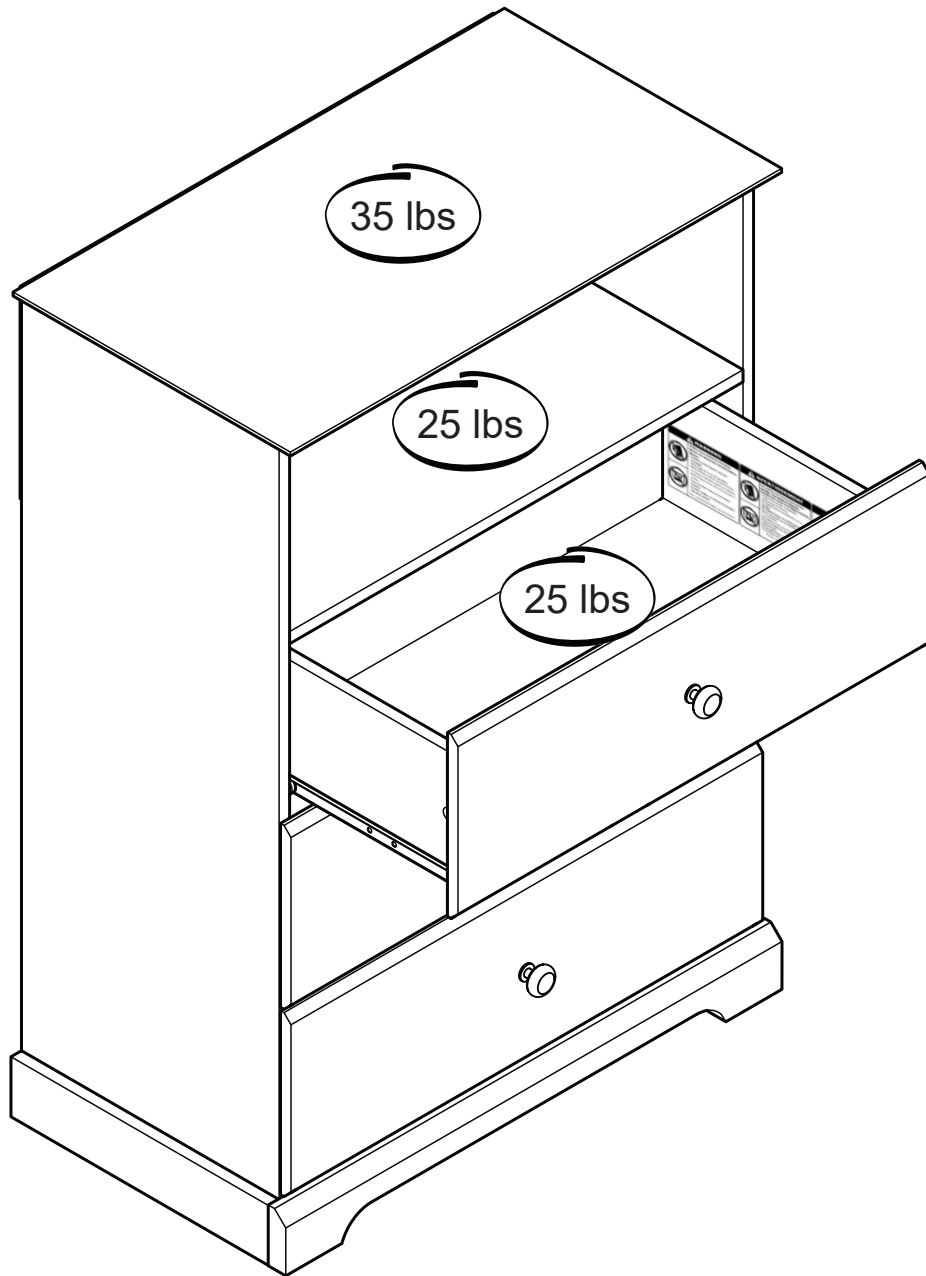

This product is designed to withstand the weight vindicated on the plan. We are not responsible for the breakage of parts or any injury caused by failure to comply with this recommendation.

Este producto está diseñado para soportar el peso indicado en el plan. No somos responsables de la rotura de piezas o cualquier lesión causada por el incumplimiento de esta recomendación.

Ce produit est conçu pour résister au poids indiqué sur le plan. Nous ne sommes pas responsables de la rupture de pièces ou de toute blessure causée par le non-respect de cette recommandation.

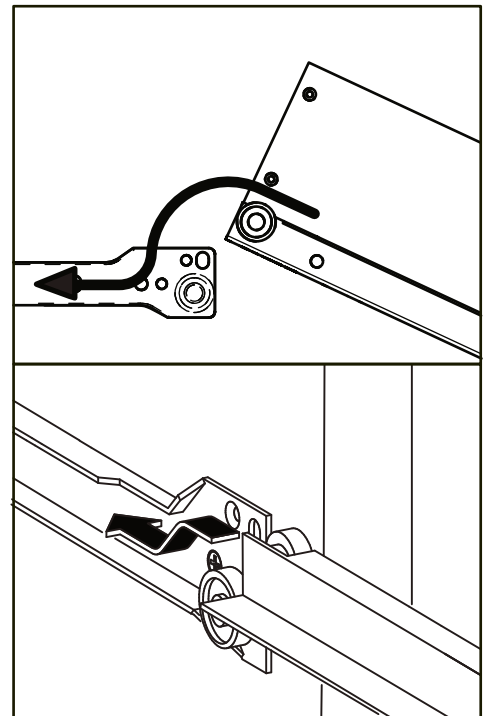

# DOIN' THE Happy Dance?

Connect with us! Share a photo of you and your new piece of furniture with the hashtag #HillsdaleHome or tag us and you could be featured on Hillsdale's Social Media!

[www.HillsdaleFurniture.com](http://www.HillsdaleFurniture.com)



## UH OH!

Is there a product defect, a part missing, or questions on how to best assemble?

**We want to help!**

Call or email our Support Team below:

[directship@hillsdalefurniture.com](mailto:directship@hillsdalefurniture.com)

502-562-0000