

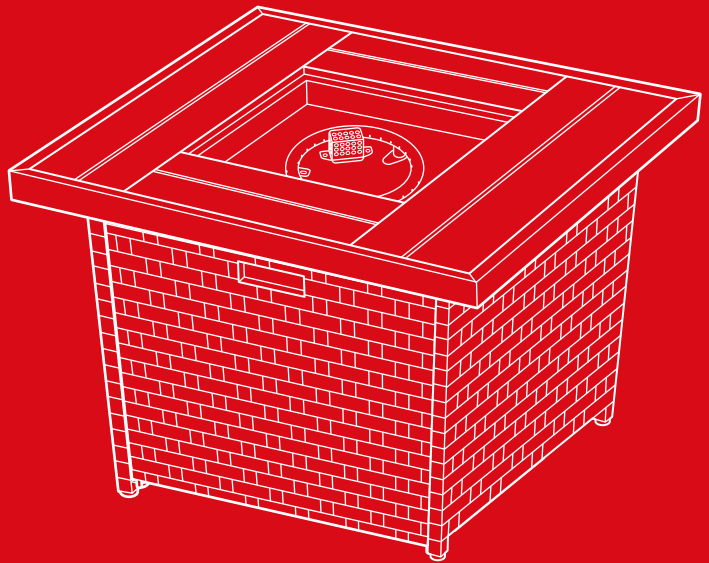

BEST CHOICE
PRODUCTS



INSTRUCTION MANUAL

28-Inch Wicker Fire
Pit Table



WARNING: DO NOT LEAVE FIRE PIT UNATTENDED WHEN IN USE

- This product is intended for use on **non-flammable surfaces only**.
- Do not use on fabric, carpets, rugs, or wood and outdoor decks.
- Do not use this product near a side wall.

FUEL HOSE

- Do not allow the feed hose to contact the burner tray or fire bowl as this could cause a gas leak, fire, personal injury, and death.
- Check the hose before each use.
- A damaged, bad, or failing hose should not be used.
- Regulator and hose must go through the black ring when installing the gas tank.

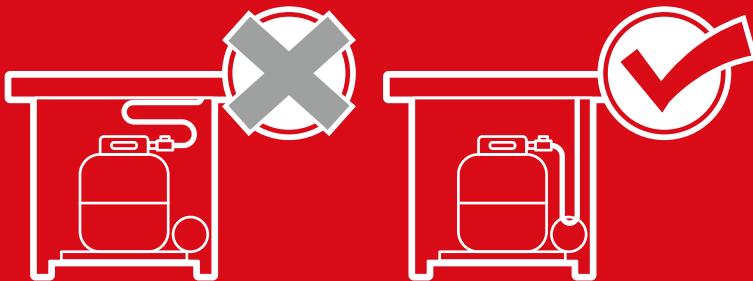

IF YOU SMELL GAS OR BURNING RUBBER

- Do not attempt to light appliance.
- Extinguish flames and disconnect tank.
- Move people away from the immediate area.

NOTICE

Please retain these instructions for future reference.

FOR RESIDENTIAL USE

- For outdoor use only; do not use in a building, garage, or any other enclosed area.
- Fire pit operates at reduced efficiency in temperatures below 40°F or wind velocity higher than 10 mph.
- Only use this appliance on a hard and level surface such as concrete or rock.
- Do not use on plastic composite or artificial wood decks.
- Fire pit can be used with a propane tank or natural gas tank.
- Children are not allowed to operate this fire pit.
- Fire pit must be attended by adults at all times. Do not leave children and pets around a fire pit when in use.
- Do not stand on or use any part of this item as a step ladder.
- Fasten screws loosely during initial assembly. Do not firmly tighten the screws until the item is completely assembled.
- Improper adjustment, installation, usage, and maintenance could result in an explosion and cause serious injury or property damage.
- Read and follow all warnings and instructions thoroughly before appliance assembly, service, and use.
- Failure to follow warnings and instructions may cause death, serious injury, or property damage.
- If any parts are missing, broken, damaged, or worn, stop using this product until repairs are made and/or factory replacement parts are installed.
- Do not use this item in a way inconsistent with the manufacturer's instructions as this could void the product warranty.

CALIFORNIA PROPOSITION 65

 **WARNING:** This product can expose you to Carbon monoxide, which is known to the State of California to cause birth defects or other reproductive harm. For more information go to www.P65Warnings.ca.gov

WARNING

- This fire pit produces carbon monoxide which has no odor. Do not use in enclosed area.
- If you smell gas during operation, immediately shut off gas and extinguish flames.
- Do not use a flame to check for gas leaks.
- Do not use this fire pit under trees or near any other unprotected combustible area.
- Fire pit must have a minimum clearance of 72 inches above and 36 inches from the sides. Make sure area is clear and free from combustible objects/constructions.
- Do not connect to a remote gas supply.
- Do not use solid fuel or charcoal on this fire pit.
- Do not burn anything other than what is provided.
- Do not place clothing or flammable materials near the fire pit.
- Fire pit is not intended for cooking.
- Do not place food or eat on the surface of fire pit.
- Be careful when igniting fire pit as flame may flare and cause injury.
- Do not pour water onto any part of the fire pit.
- Keep a safe distance from the fire pit when in use. Do not sit or rest hands/feet on fire pit.
- To avoid burns, do not touch or move any part of this fire pit when in use; wait until it has completely cooled.
- Do not breathe smoke from the fire pit and avoid getting smoke in your eyes.
- Do not alter this appliance. Any alteration can cause a safety hazard.
- Do not use any accessory or fitting other than original accessories and fittings.
- Keep all electrical cords and hoses away from heated surfaces.
- Routinely check hoses for wear or abrasions. Do not use if hoses are damaged.
- Be aware that items stored under the fire pit will be subject to radiant heat and could be damaged.

PROPANE TANK WARNINGS

- Make sure to organize fuel hose to prevent accidental tripping.
- Only use standard 20-pound propane tanks.
- Maximum gas supply pressure is 250 PSI.
- Do not fill tank more than 80% of its capacity.
- Do not use tank if any part of it is damaged; rust and dents can be dangerous.
- Propane tank must have a collar to protect the gas valve.
- Using too much propane gas may result in gas pooling and will not burn.
- Check for leaks by brushing a mixture of soap and water on all connections. If large bubbles form when gas is turned on, there may be a leak.
- If you smell gas:
 - Do not attempt to light appliance.
 - Extinguish flames and disconnect tank.
 - Move people away from the immediate area.
- Do not try to repair leaking tank. Contact a professional to repair or replace tank.

TOOLS REQUIRED



ALLEN WRENCH
(PROVIDED)



1 PERSON
ASSEMBLY



UP TO 30 MIN.
ASSEMBLY

HARDWARE

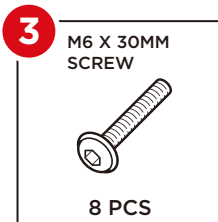
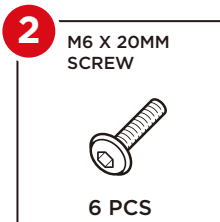
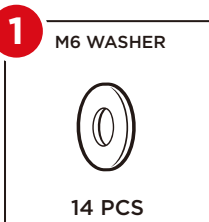

PARTS

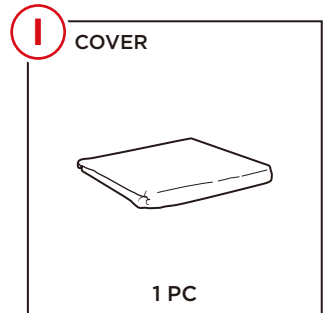
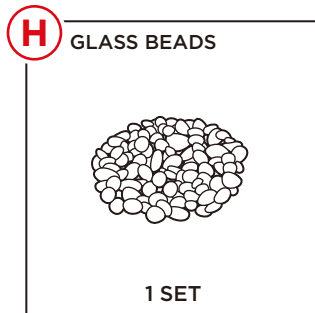
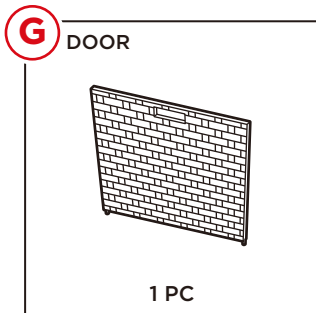
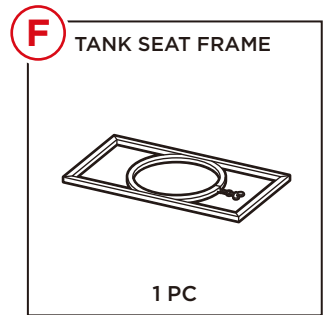
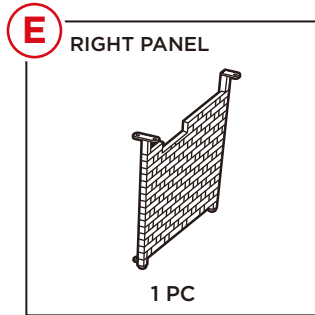
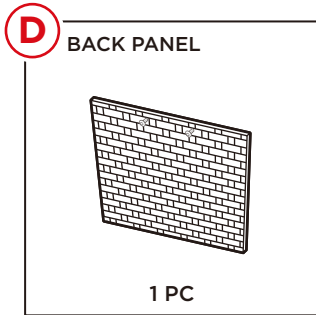
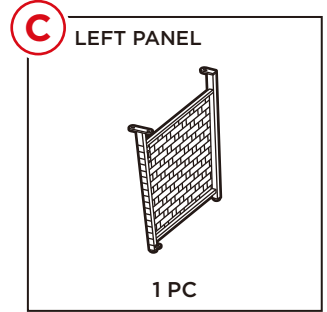
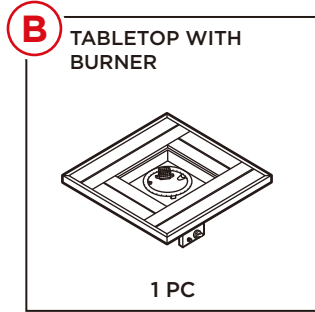
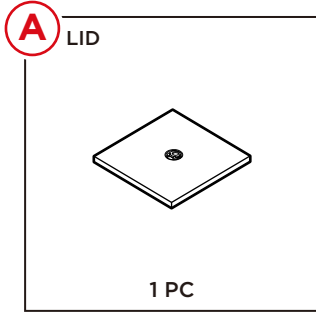

PRODUCT ASSEMBLY

1

Attach **part D** back panel to **part C** left panel with two **part 3** screws and two **part 1** washers.

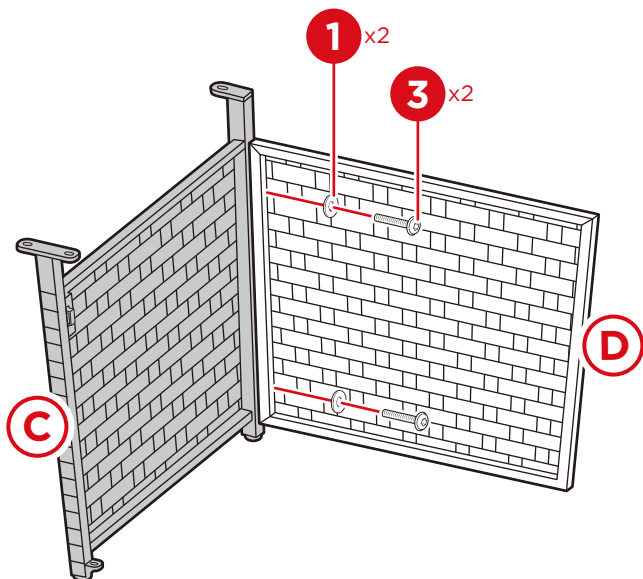

2

Attach **part F** tank seat frame with two **part 3** screws and two **part 1** washers.

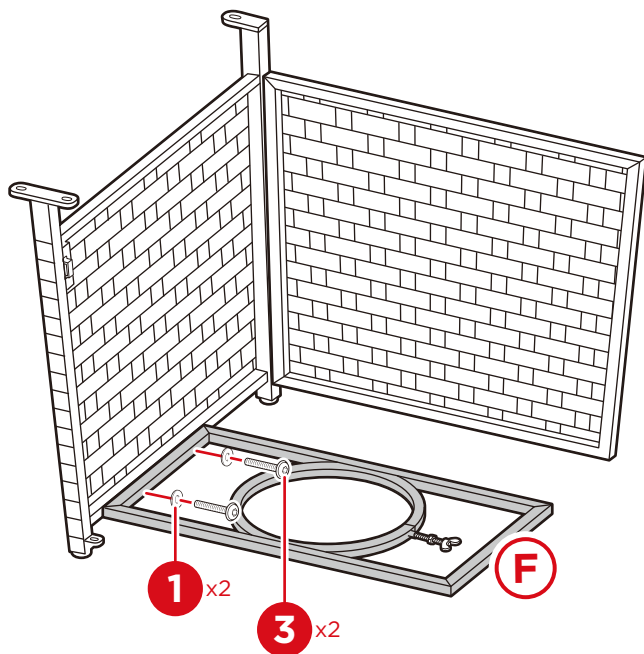

PRODUCT ASSEMBLY

3

Attach **part E right panel** with four **part 3 screws** and four **part 1 washers**.

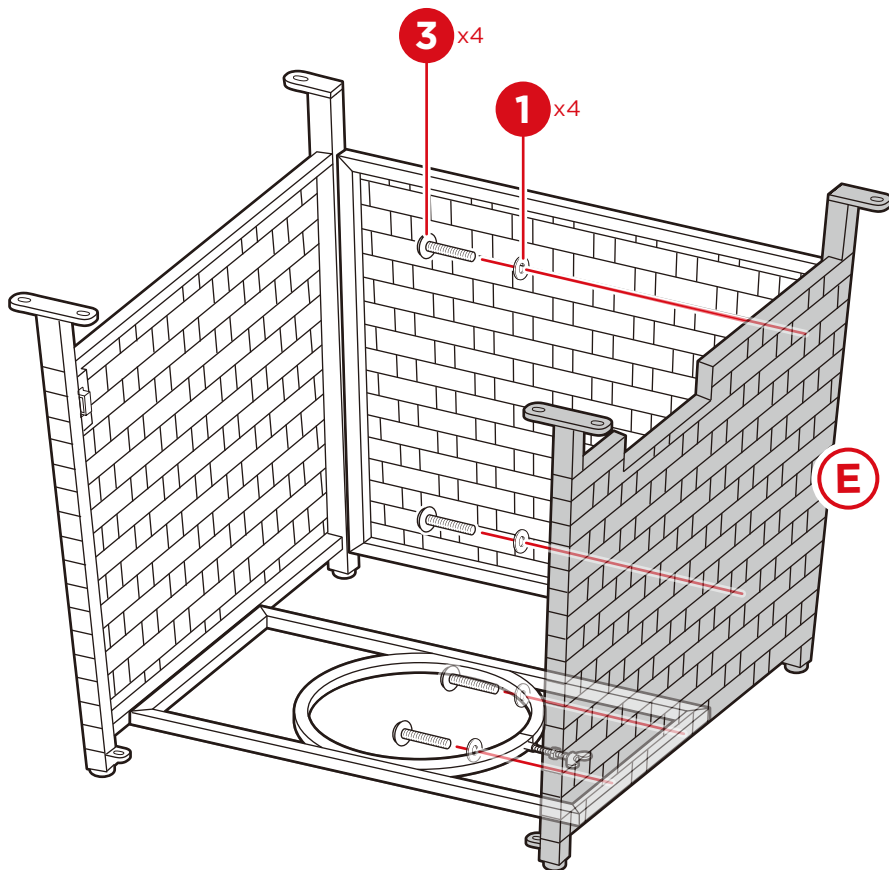

PRODUCT ASSEMBLY

4

Insert the **part G door** into the designated holes and secure with the magnetic catches.

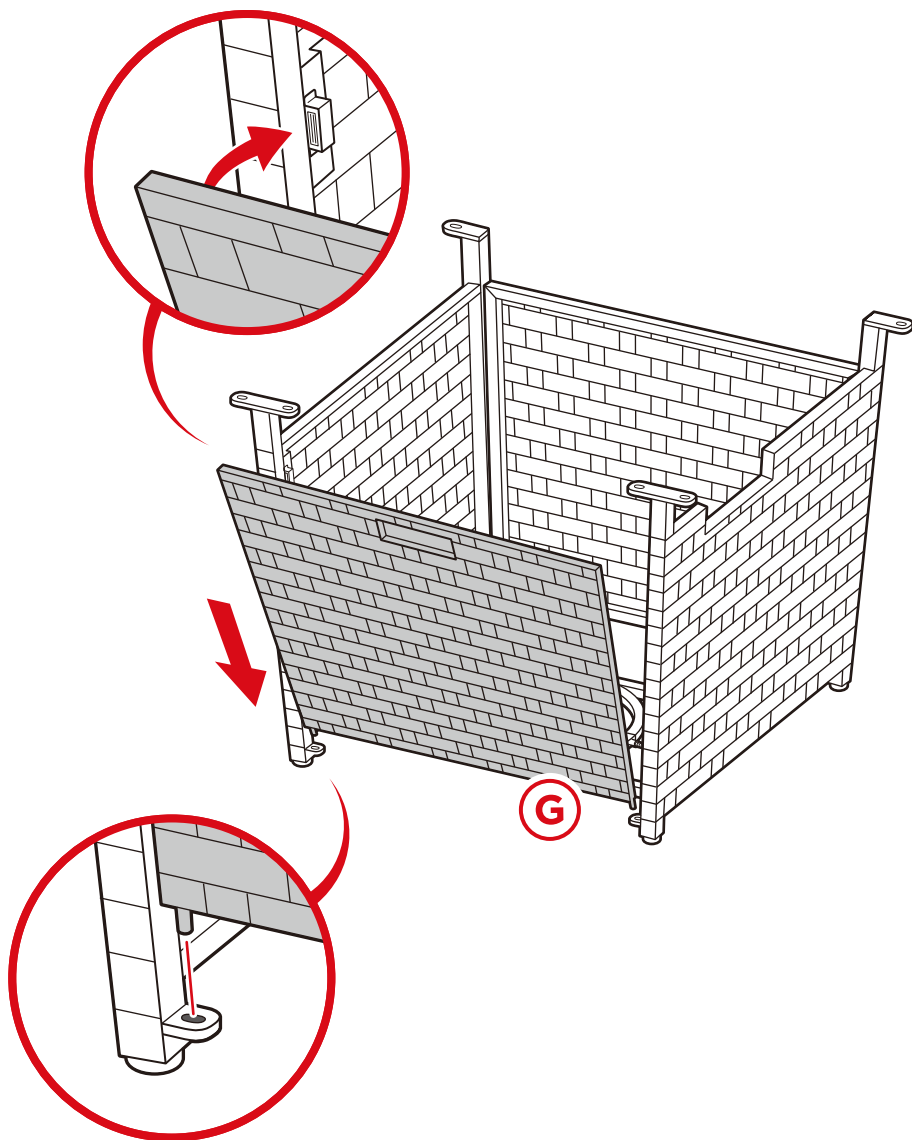

PRODUCT ASSEMBLY

5

Carefully flip the table base over and attach it to the **part B tabletop** with six **part 2 screws** and six **part 1 washers**.

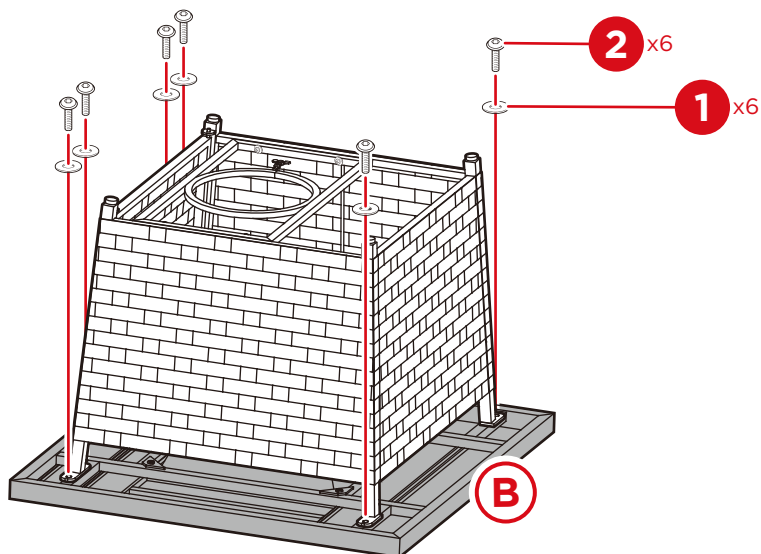

6

Place the **part H glass beads** (see Placing Glass Beads section).

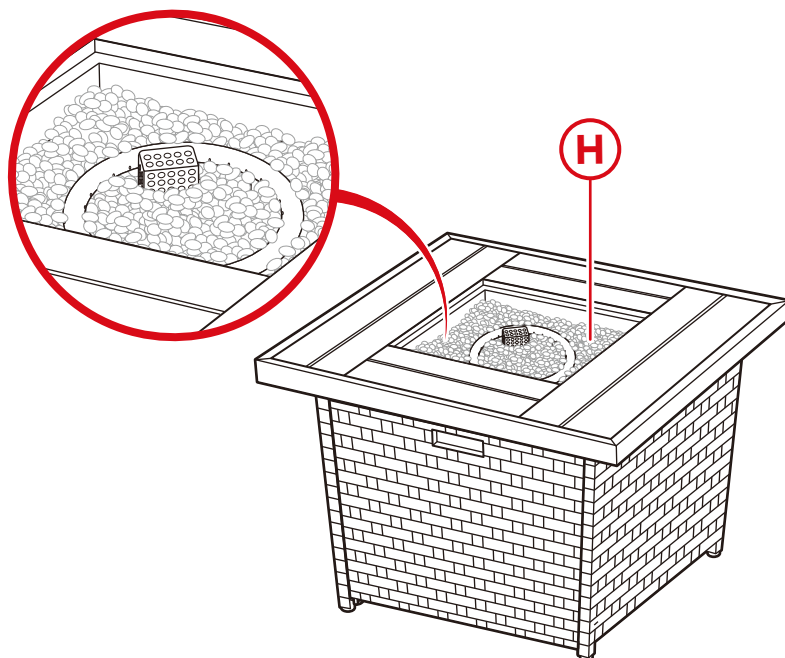

PRODUCT ASSEMBLY

7

Place the **part A lid**.
Hang lid on hangers when not in use.

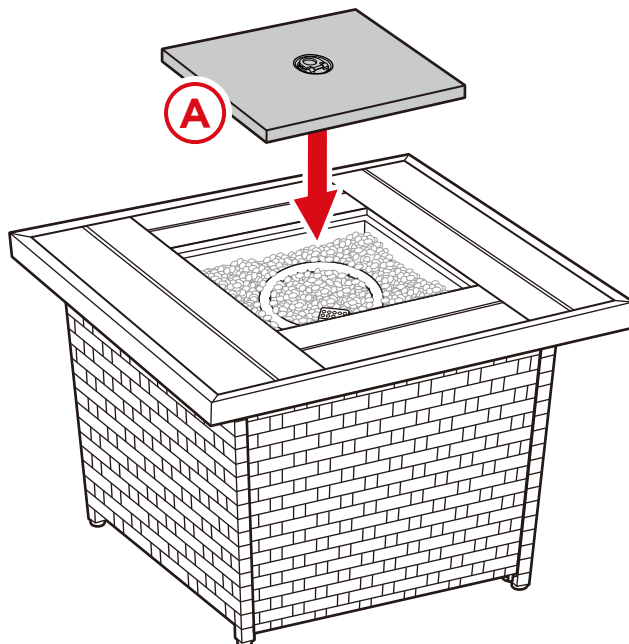

BACK VIEW

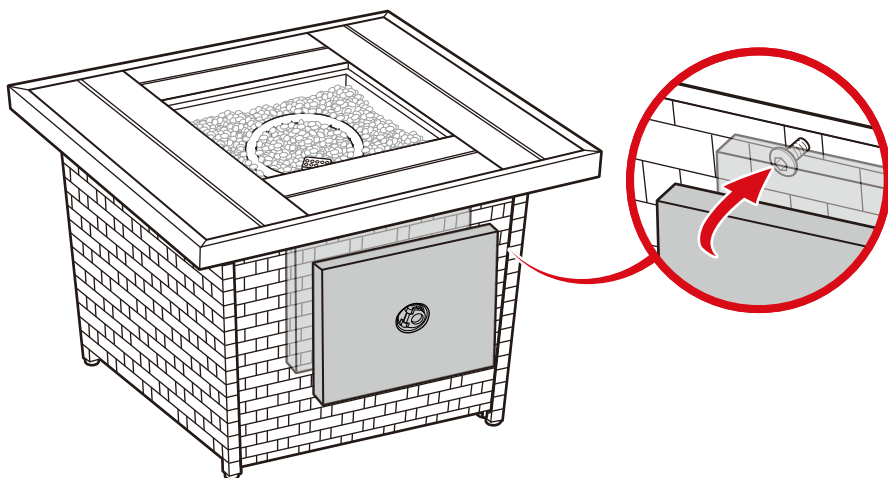

DIAGRAM

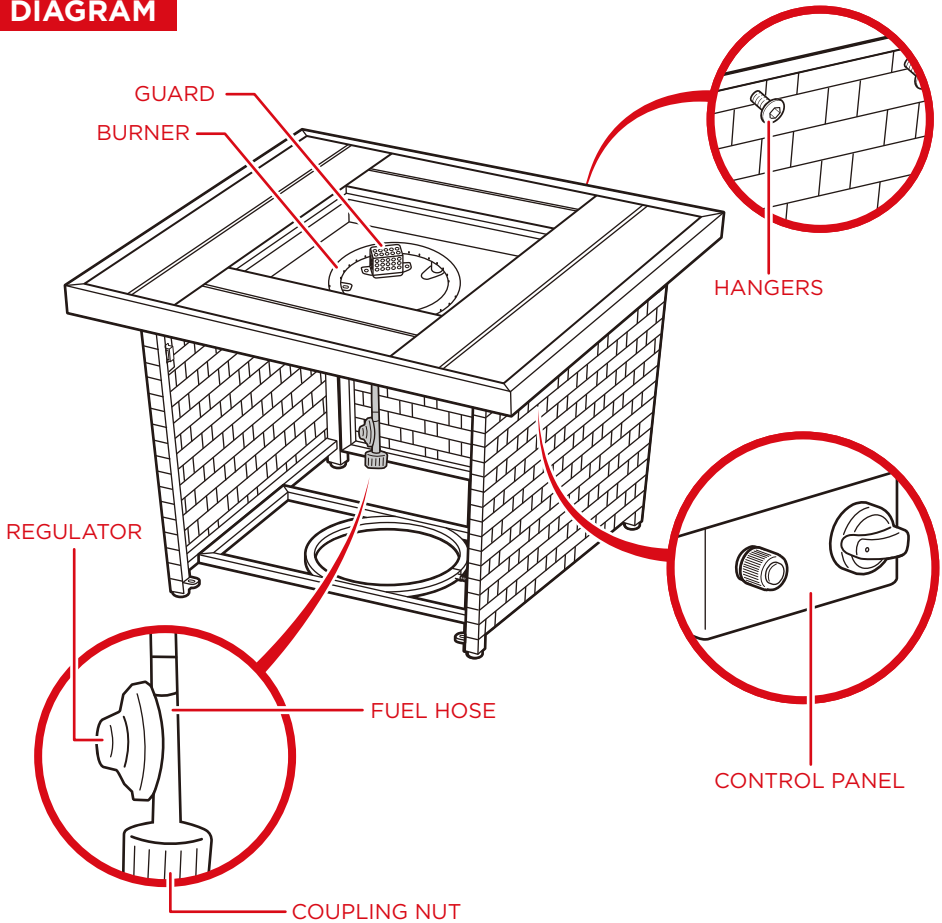

PLACING GLASS BEADS

- Place glass beads in fire pit and spread them according to your preference.
 - You may place glass beads around the burner but do NOT cover the guard.
- Excessive glass beads will suffocate the flame.

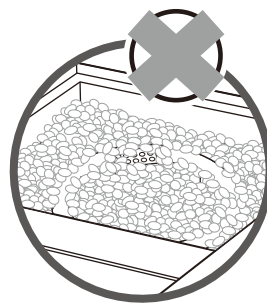
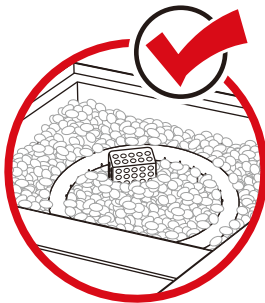

INSTALLING PROPANE TANK

1

NOTE: Only use standard 20-pound propane tanks.

Pull handle and remove door. Place propane tank on the tank seat frame. Turn wingnut clockwise to secure tank.

Make sure release valve on tank is firmly screwed shut.

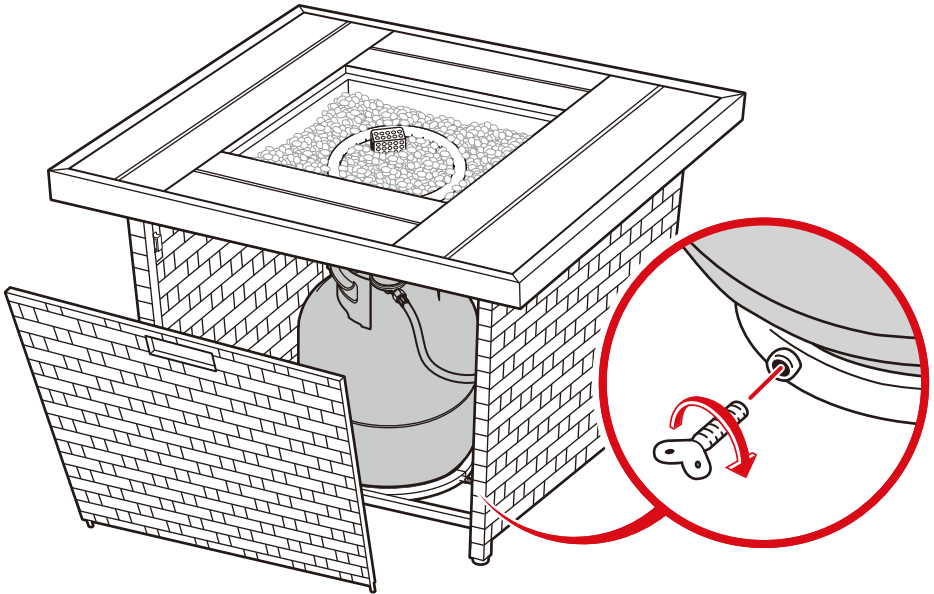

2

Attach fuel hose regulator to the output of the tank by turning the coupling nut clockwise.

- If door does not close, adjust position of tank and hose until door closes.

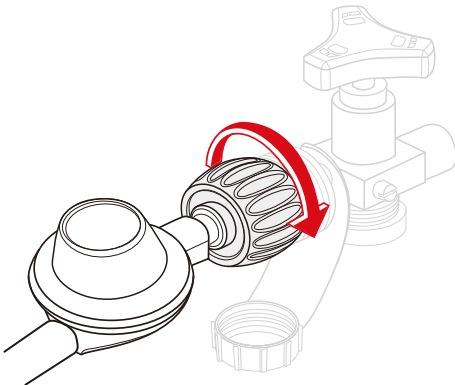

3

Turn release valve on tank counterclockwise to release gas.

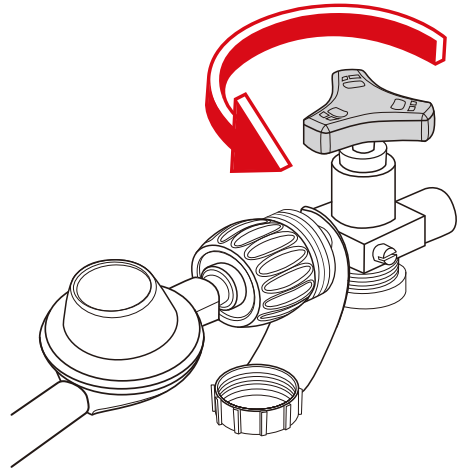

CONTROL PANEL

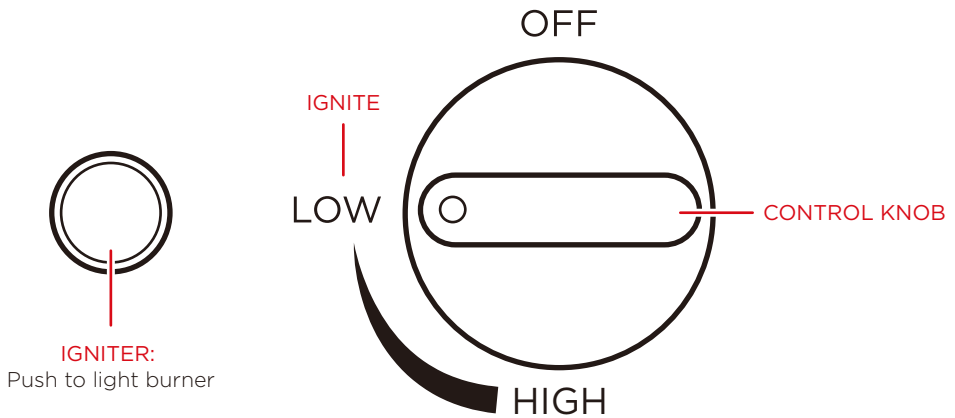

OPERATING INSTRUCTIONS

NOTE: Before use, inspect burner, propane tank, and connectors for damage, debris, obstructions, or dirt. Do not operate if there is any blockage.

1. Push and turn control knob counterclockwise to low/ignite.
2. Press the ignitor button repeatedly to light burner.
 - If flames do not ignite after 45 seconds, turn off, wait 5 minutes, and try again.
 - If necessary, keep control knob pushed in while pressing ignitor button.
 - If necessary, carefully light burner with a match or lighter. When lighting, do not push and hold control knob for more than 10 seconds.
3. Adjust flames with the control knob.
4. When finished, push and turn control knob clockwise to off position. Place lid to cover the burner and glass beads.
5. Turn valve on propane tank clockwise to turn off gas flow.

CLEANING

- Make sure fire pit is completely cool before cleaning or storage.
- Use a soft brush or cloth to wipe stains and dirt.
- If necessary, clean with mild detergent and a soft cloth/sponge.
- Black soot may develop on glass beads after use; use a damp cloth to clean debris as needed.
- Thoroughly dry fire pit after cleaning.
- Do not submerge control panel or burner assembly in water.
- Do not use petroleum-based or abrasive cleaners as it may damage the finish.
- Do not use rough or harsh sponges/brushes.
- Do not clean fire pit in a self-cleaning oven.
- Do not enlarge burner holes when cleaning burner.

STORAGE

- Allow fire pit to cool 10 minutes before storage.
- Disconnect propane tank when putting fire pit in storage. Do not store propane tank in the vicinity of the fire pit.
- Store fire pit upright in an area sheltered from inclement weather, such as rain, sleet, hail, snow, dust or debris.
- Do not store propane tank in temperatures over 120°F.
- Place cover on fire pit to protect from harsh weather.
- Do not store in direct sunlight.
- Do not store/use gasoline, or any other flammable vapors or liquids, in the vicinity of the fire pit.
- It is recommended that the fire pit is stored indoors during winter.
- If fire pit is stored indoors, disconnect and leave propane tank outdoors.

TROUBLESHOOTING

PROBLEM	REASON	SOLUTION
Burner not lighting with igniter	Guard obstructed	Clear guard of obstructions
	Burner wet	Dry burner
Burner does not light	Propane tank is empty	Replace/refill tank
	Coupling nut loose	Fully tighten coupling nut
	Bent hose	Straighten hose
	Burner holes obstructed	Remove obstructions or clean holes
	Control knob off	Turn control knob on
Emits a lot of black smoke	Bent hose	Straighten hose
	Burner holes obstructed	Remove obstructions or clean holes
	Dirt or film on burner	Clean burner
Drop in gas flow, reduced flame height	Propane tank is empty	Replace/refill tank
	Temperature less than 40°F, tank less than ¼ full	
Irregular flame pattern, or does not run length of burner	Burner holes obstructed	Remove obstructions or clean holes
Flames blow out	Propane tank is empty	Replace/refill tank
	High winds	Turn control knob to high
Flames lose heat in cold weather	Ice buildup on propane tank	Replace tank



HELP CENTER



Question about your product? We're here to help. Visit us at:

help.bestchoiceproducts.com



Product Assembly



Returns & Refunds

PRODUCT WARRANTY INFORMATION

All items can be returned for any reason within 60 days of the receipt and will receive a full refund as long as the item is returned in its original product packaging and all accessories from its original shipment are included. All returned items will receive a full refund back to the original payment method. All returned items will not be charged a re-stocking fee.

All returned items require an RA (Return Authorization) number, which can only be provided by a Best Choice Products Customer Service Representative when the return request is submitted. Items received without an RA may not be accepted or may increase your return processing time. Once an item has been received by Best Choice Products, refunds or replacements will be processed within 5 business days.

All returns must be shipped back to the Best Choice Products Return Center at the customer's expense. If the reason for return is a result of an error by Best Choice Products then Best Choice Products will provide a pre-paid shipping label via email. Boxes for return shipping will not be provided by Best Choice Products, and is the customer's responsibility to either use the original shipping boxes or purchase new boxes.

Pictures may be required for some returns to ensure an item is not damaged prior to its return. Items returned are not considered undamaged until they are received by Best Choice Products and verified as such. All damages to items are the customer's responsibility until the item has been received by and acknowledged by Best Choice Products as undamaged.

WARNING

Manufacturer and seller expressly disclaim any and all liability for personal injury, property damage or loss, whether direct, indirect, or incidental, resulting from the incorrect attachment, improper use, inadequate maintenance, unapproved modification, or neglect of this product.