

# BLACK DIAMOND®

Project Name: \_\_\_\_\_

Location: \_\_\_\_\_

Item #: \_\_\_\_\_

Qty: \_\_\_\_\_

## Black Diamond Refrigerated Pizza Prep Table, 2 Solid Doors, 18 Cu. Ft. Capacity, in Stainless Steel

### GRPZ-2D/67



Enhance your kitchen efficiency with the Black Diamond Refrigerated Pizza Prep Table, designed for the demanding needs of commercial kitchens. Constructed with a stainless steel exterior and doors, it ensures durability and easy maintenance. This pizza prep fridge boasts an 18 cubic feet capacity, maintaining temperatures between 33° and 40°F. Equipped with R290 refrigerant, fully automatic controller, and auto defrost, it simplifies operation. Cleaning is straightforward, thanks to its user-friendly design.

### FEATURES AND CONSTRUCTION

- Offers 18 Cu. Ft. of storage capacity for ample ingredient space
- Equipped with a 0.75 horsepower compressor for efficient cooling
- Constructed with stainless steel for durability and easy cleaning
- Maintains a temperature range of 33° to 40°F to keep ingredients fresh and safe
- Utilizes R290 refrigerant for eco-friendly cooling
- Operates on 115V with a NEMA-5-15P plug type
- Includes two adjustable shelves for customizable storage
- Comes with four 4-inch casters, 2 locking and 2 non-locking, for easy mobility
- Features self-closing doors to ensure temperature retention
- Digital temperature control ensures precise cooling

### STORAGE CAPACITY

- Cubic Feet: 18 Cu. Ft.

### TEMPERATURE

- Holding Temperature (Fahrenheit): 33° - 40°

These models are designed to operate in an environment where temperature and humidity do not exceed 75°F (24°C) and 55% relative humidity

### ELECTRIC

115VV / 60Hz / 1Ph

Cord Length (Inches): 98.40"

Plug Type: NEMA 5-15P

Cord set included

NEMA 5-15P



### 3RD PARTY APPROVALS



### WARRANTY (USA / CANADA)

Two (2) Year Limited Warranty on Parts and Labor, Five (5) Year Warranty on Compressor and Evaporator

Contact us for details at 1.877.368.2797





# Black Diamond 2 Door Refrigerated Pizza Prep Table

GRPZ-2D/67

FRONT

SIDE

FRONT

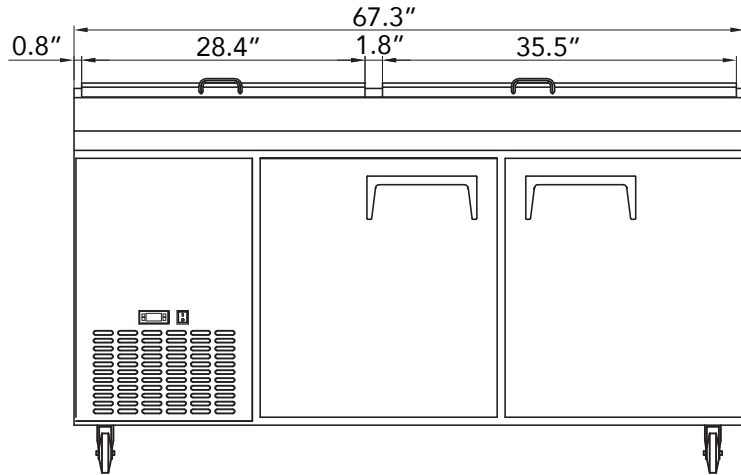

SIDE

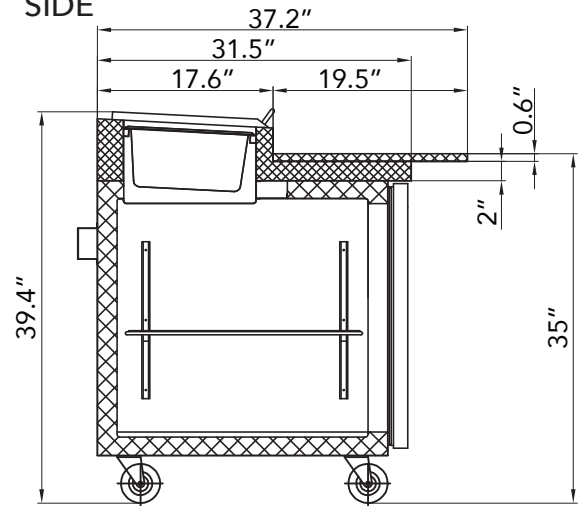

TOP

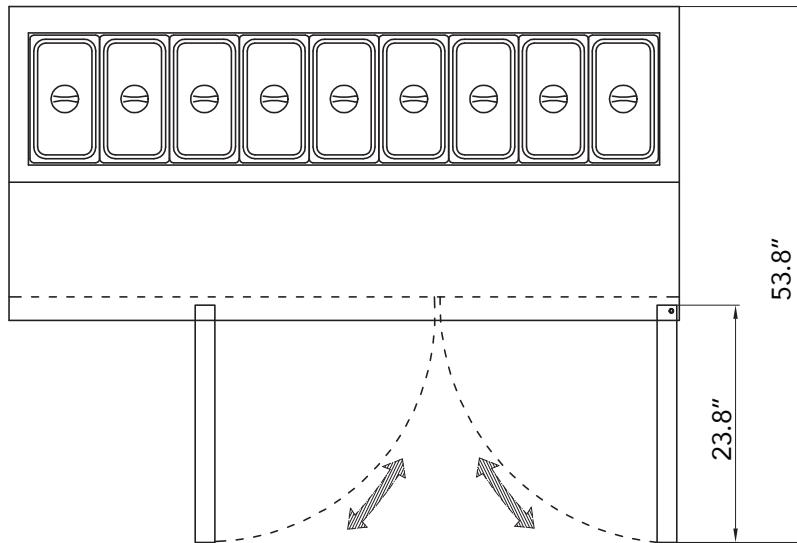

TOP

## Prep Table

Doors	Shelves	Amps	HP	Refrigerant	Capacity	Assembled Dimensions (in)	Item Weight (lbs)	Shipping Weight (lbs)
2	2	4.8A	0.75	R290 3.883	18 Cu. Ft.	31.50" x 67.30" x 39.40"	244.2	451.0

Due to periodic changes in designs, methods, procedures, policies and regulations, the specifications contained in this document are subject to change without notice. While we exercise good faith efforts to provide information that is accurate, we are not responsible for errors or omissions in information provided or conclusions reached as a result of using the specifications. By using the information provided, the user assumes all risks in connection with such use.