

**WALKER EDISON**  
™

# Lee 9 Drawer Dresser

SKU: BR9DRLEEDR-T  
LOT: **AAYYWW-XXX**



*For Residential Use Only*

Please visit our website for the most current instructions, assembly tips, to report damage, or request parts. [www.walkeredison.com](http://www.walkeredison.com)

# WE Time to get started

Set up a clean and soft workplace to avoid damage during assembly. You can use the box and internal protections as a cover. It also helps to double-check if you have got all the pieces and parts before diving in assembly.

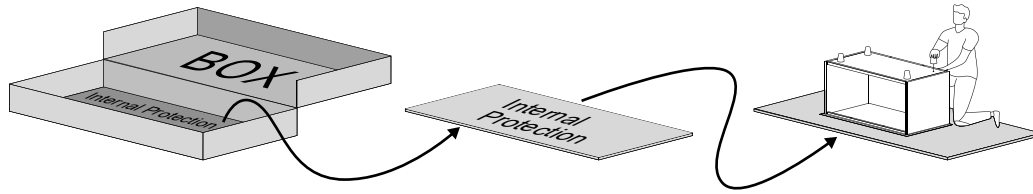

**Estimated time for assembly**

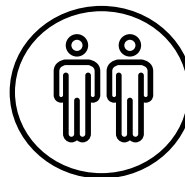

2 Person Build

**People recommended for assembly.**

Make it a team effort!  
Grab a friend for quicker, easier assembly.

## Tools Needed

Grab a Phillips head screwdriver and a hammer to conquer this assembly.

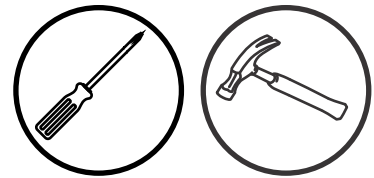

## Use power tools with caution

This furniture is made of Solid Wood and Composite Wood, soft materials. If you choose to use power tools, set it to the slower setting. Be careful! Power tools can cause cracking or damage to the furniture, they can also damage the hardware if misused. Power tool damages are not covered by the Walker Edison warranty

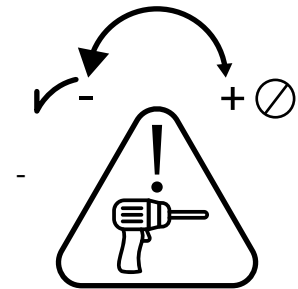

## Slide care

Your furniture has highly durable wooden sliders. From time to time we recommend applying paraffin or standard candle wax to improve gliding of the sliders.

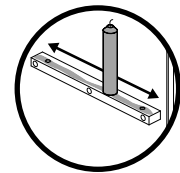

**Scan to get assembly tips and help!**

# WE Part List

Part Number	Description	Quantity
01	Top panel	01
02	Left side panel	01
03	Right side panel	01
04	Base	01
05	Left Drawer Side	06
06	Right Drawer Side	05
07	Right Drawer Side (Warning)	01
08	Drawer Front	06
09	Drawer Bottom	06
10	Drawer Back	06
14	Front Rail	04
15	Large Front Rail	02
16	Division	01

Part Number	Description	Quantity
17	Wood Slider	18
18	Small Division	02
19	Top Rail	01
20	Back Panel	01
21	Bottom Back Panel	01
22	Central Foot	01
23	Small Drawer Front	03
34	Bottom Front Rail	02
35	Bottom Side Rail	02
36	Foot	04
45	Small Drawer Back	03
46	Small Left Drawer Side	03
47	Small Right Drawer Side	03
48	Small Drawer Bottom	03

**WALKER EDISON**  
 Distribution and responsible for the anti-tip hardware:  
 Walker Edison Furniture Company  
 1553 W. 9000 S., West Jordan, UT 84088 United States  
 For details on Assembly Videos, Assembly Instructions, Replacement Parts and Customer Service, SCAN HERE:   
**LEE**  
 Model: XXXXXXXXFF  
 LOT: AAYYWW-XXX  
 Date: MM/20YY  
 Rev: MM/20YY-VX  
CAMPER compliant conforms to CAMPER TSCA Title VI compliant conforms to the VI in the TSCA TSCA Title VI compliant conforms to the VI in the TSCA. Conforms to the California Proposition 65 to the maximum California 0.1300 ppm to formaldehyde.

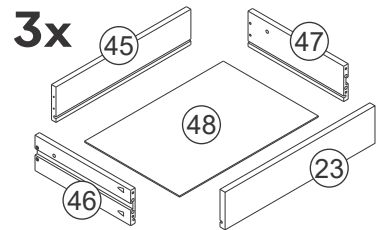
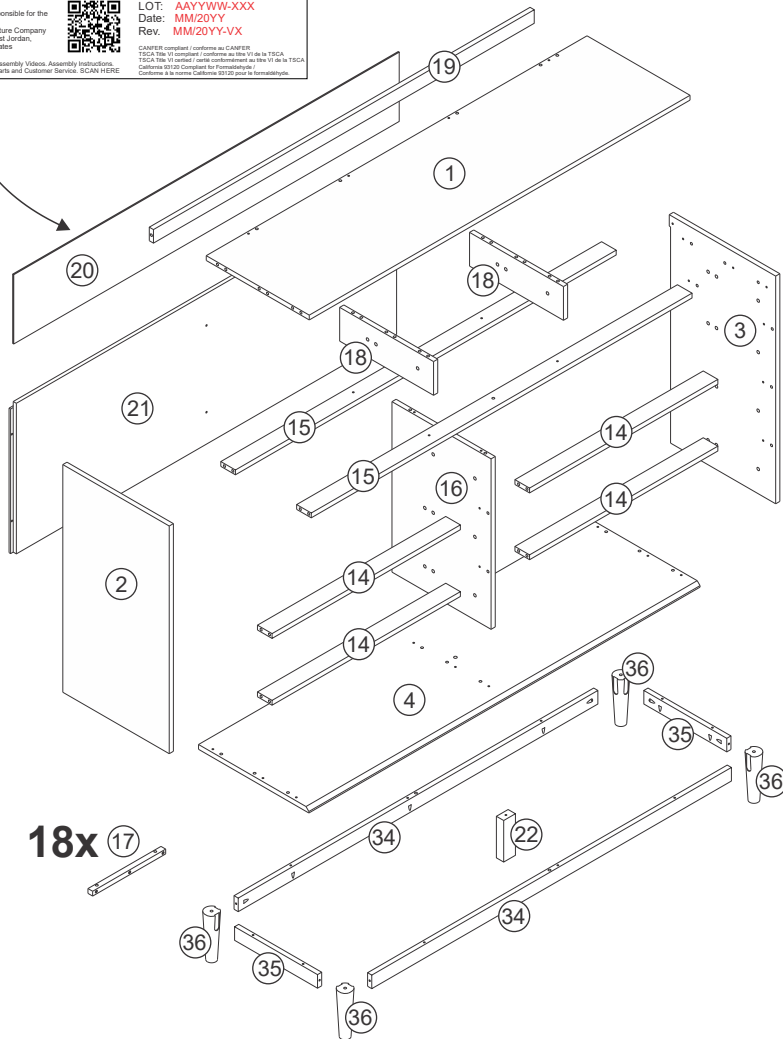

**WARNING**

Children have died from furniture tipover. To reduce the risk of furniture tipover:





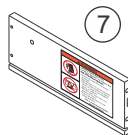

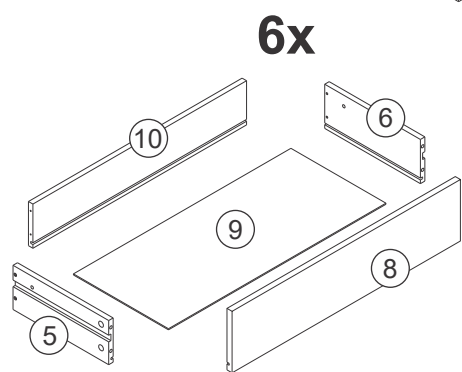



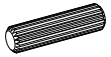

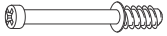

- ALWAYS install Anti-tip device provided.
- NEVER put a TV on this product.
- NEVER allow children to stand, climb, or hang on any drawers, doors, or shelves.
- NEVER open more than one drawer at a time.
- Place heaviest items in the lowest drawers.

*This is a permanent label. Do not remove!*

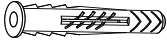
The side drawer with WARNING LABEL, should be mounted in highest drawer. 

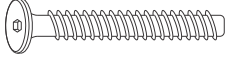
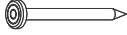
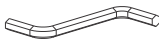

# WE Hardware List

Part	Size	Name	Quantity
A	 8x30mm	Wooden dowel	84
B	 8x40mm	Wooden dowel	18
C	 3,0x12mm	Screw	30
D	 3,5x20mm	Screw	05
E	 4,0x40mm	Screw	33
F	 5x24mm	Cam bolt	50
G	 10x20mm	Wooden dowel	54
H	 4,0x25mm	Screw	54
I	 4,0x30mm	Screw	55
J	 6x35mm	Plastic bush	01
K	 15x12mm	Cam lock	50
L	 7,0x50mm	Bolt	01
M	 8x8mm	Nail	20
N		Hex key	01
O		Washer	02
P		Wall anchor	01
Q		Handle	15

The hardware quantities listed above are required for proper assembly.  
Extra hardware pieces may be included.

# Step 1

Let's get started ! Insert wood dowel (G) into the Wooden Slider (17).

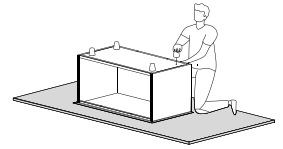

Attention to the  
dowel size:  
Ø10\*20mm

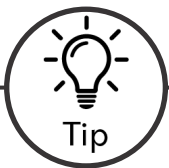
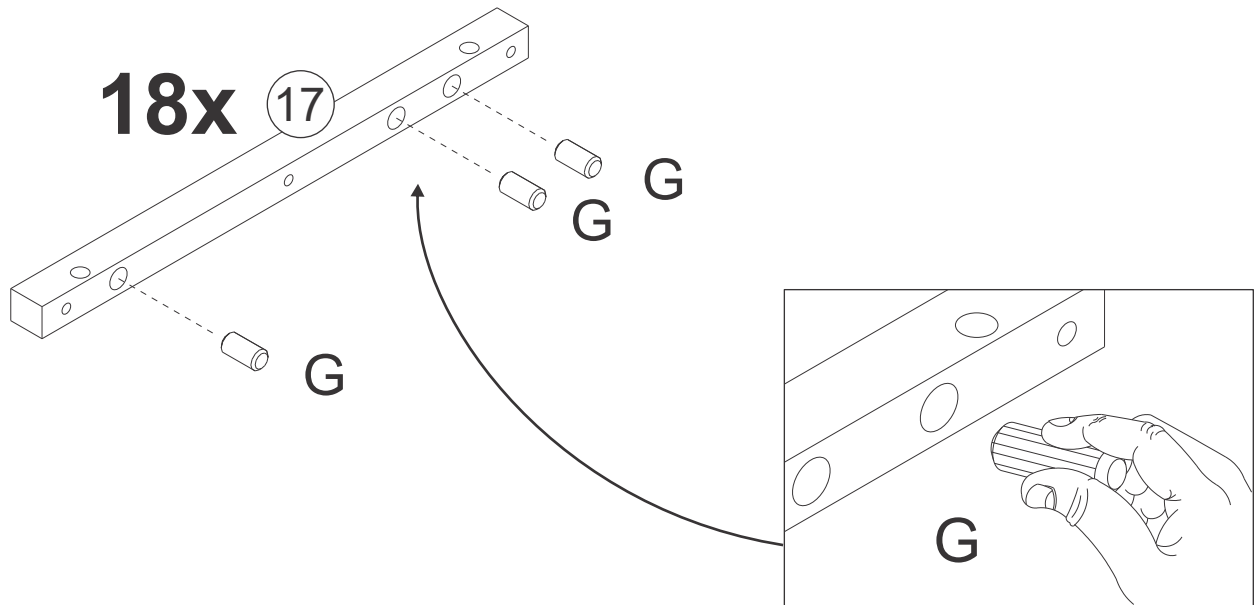
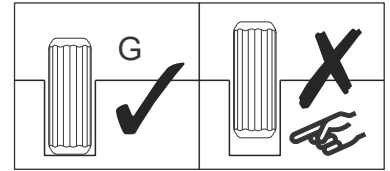

## Wood Dowels

Dowels are essential in furniture assembly  
to create strong, precise connections.

They ensure structural integrity, prevent shifting, and simplify alignment,  
resulting in sturdier, longer-lasting furniture.

Follow these steps:

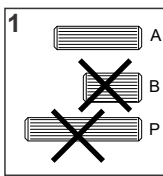

1: Select the appropriate size  
dowel according with step.

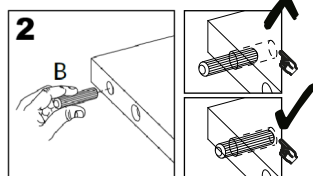

2: Insert into drilled hole and press  
firmly to ensure placement is set.

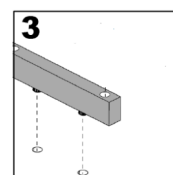

3: Align the dowel with corresponding  
piece and press together until secure.

# Step 2

Insert wooden dowel (A) into the Top Panel (01), Left Side Panel (02), Right Side Panel (03), Front Rail (14), Large Front Rail (15), Division (16), Small Division (18), Top Rail (19), Bottom Front Rail (34), Bottom Side Rail (35), Foot (36), Small Left Drawer Side (46) and Small Right Drawer Side (47).

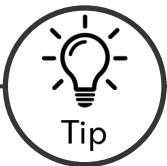
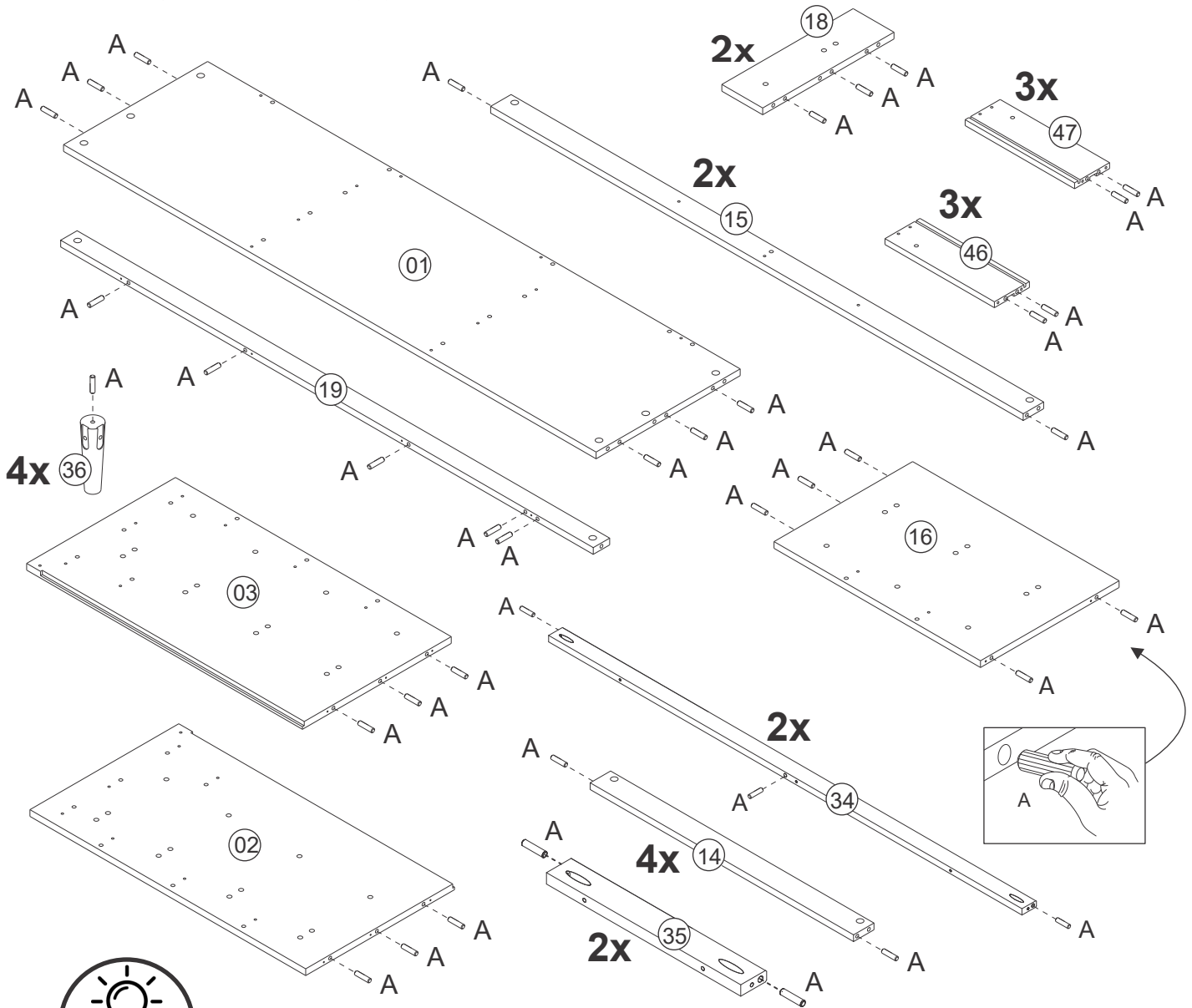

To keep your product looking its best and scratch-free, try assembling it on a soft surface like carpet or a blanket. This helps prevent any accidental scratches and keeps your furniture in top shape!

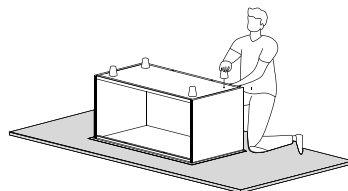

# Step 3

Secure the Wood Slider (17) to Left Side Panel (02), Right Side Panel (03), Division (16) and Small Division (18) with Screw (H) 3 and a Phillips screwdriver.

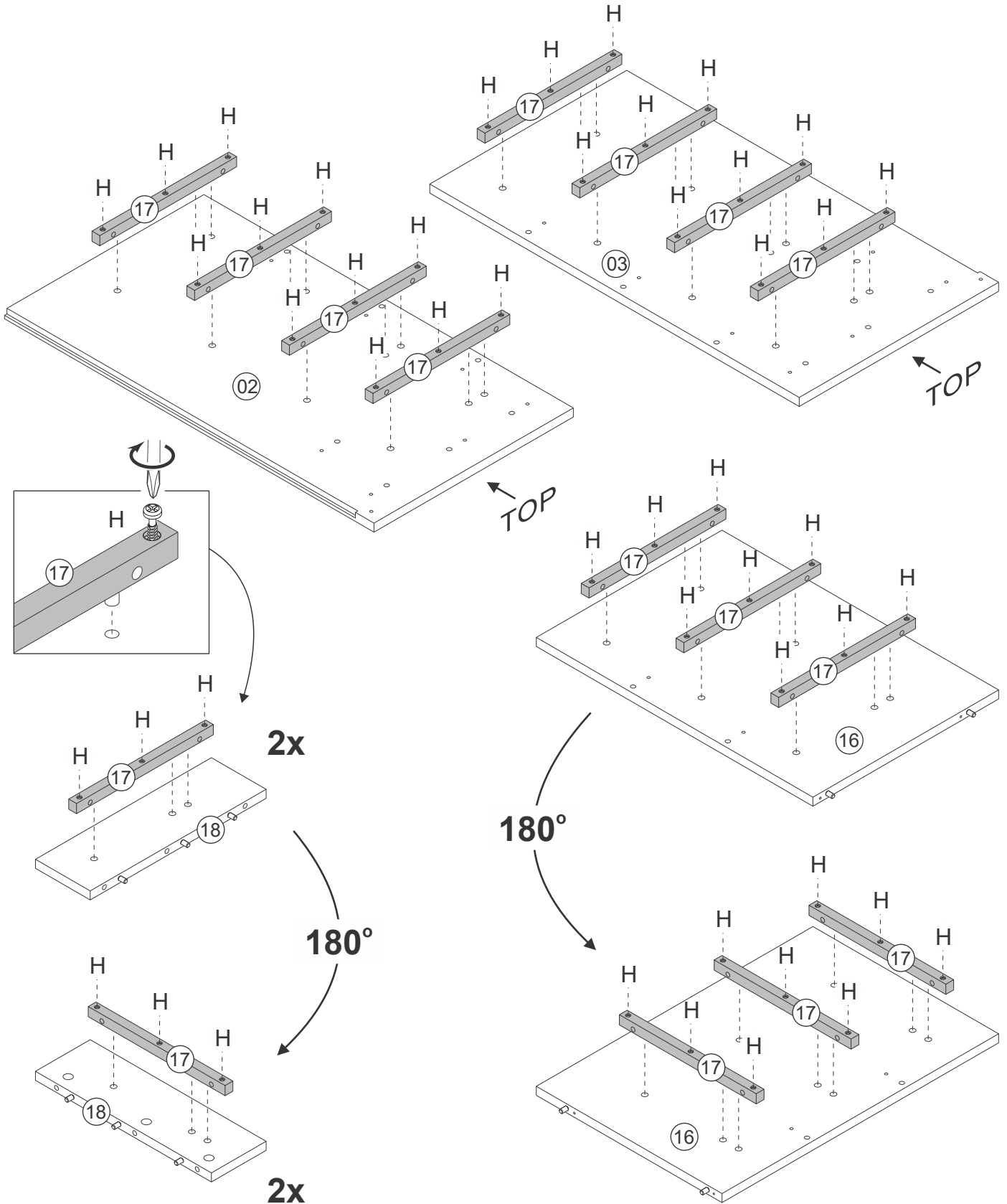
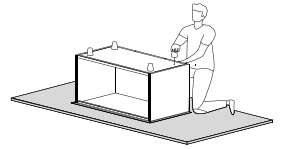

# Step 4

Attach cam bolts (F) into the Top Panel (01), Left Side Panel (02), Right Side Panel (03), Drawer Front (08) and Division (16) with a Phillips head screwdriver.

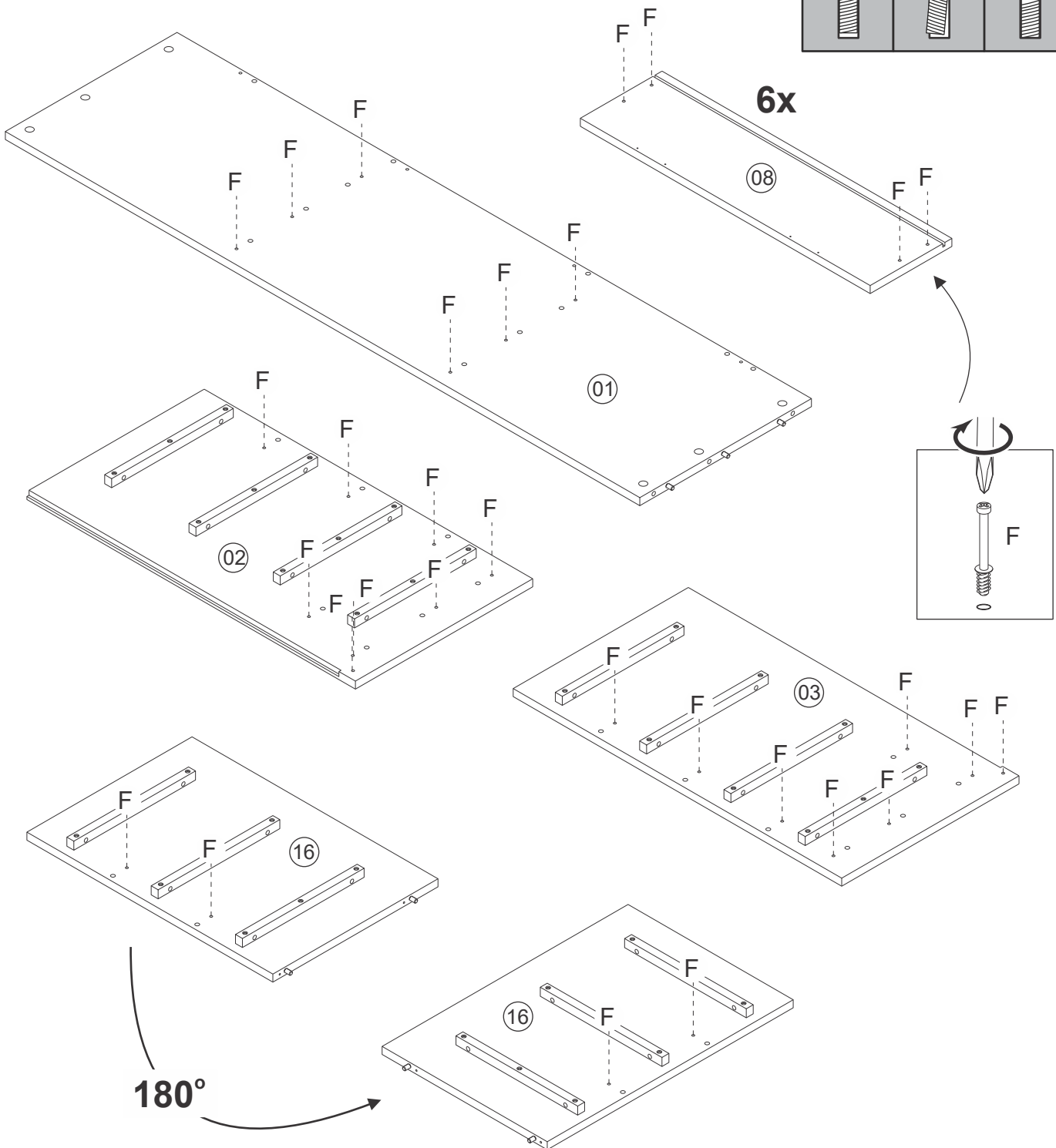
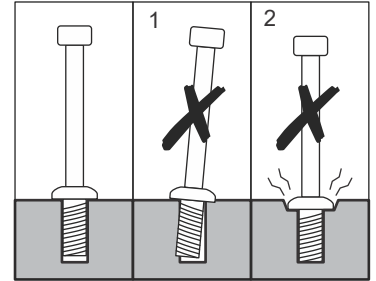
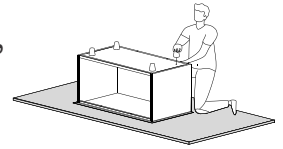



# Step 5

Secure the Top Rail (19) to Top Panel (01) using Screw (I) and a Phillips head screwdriver.

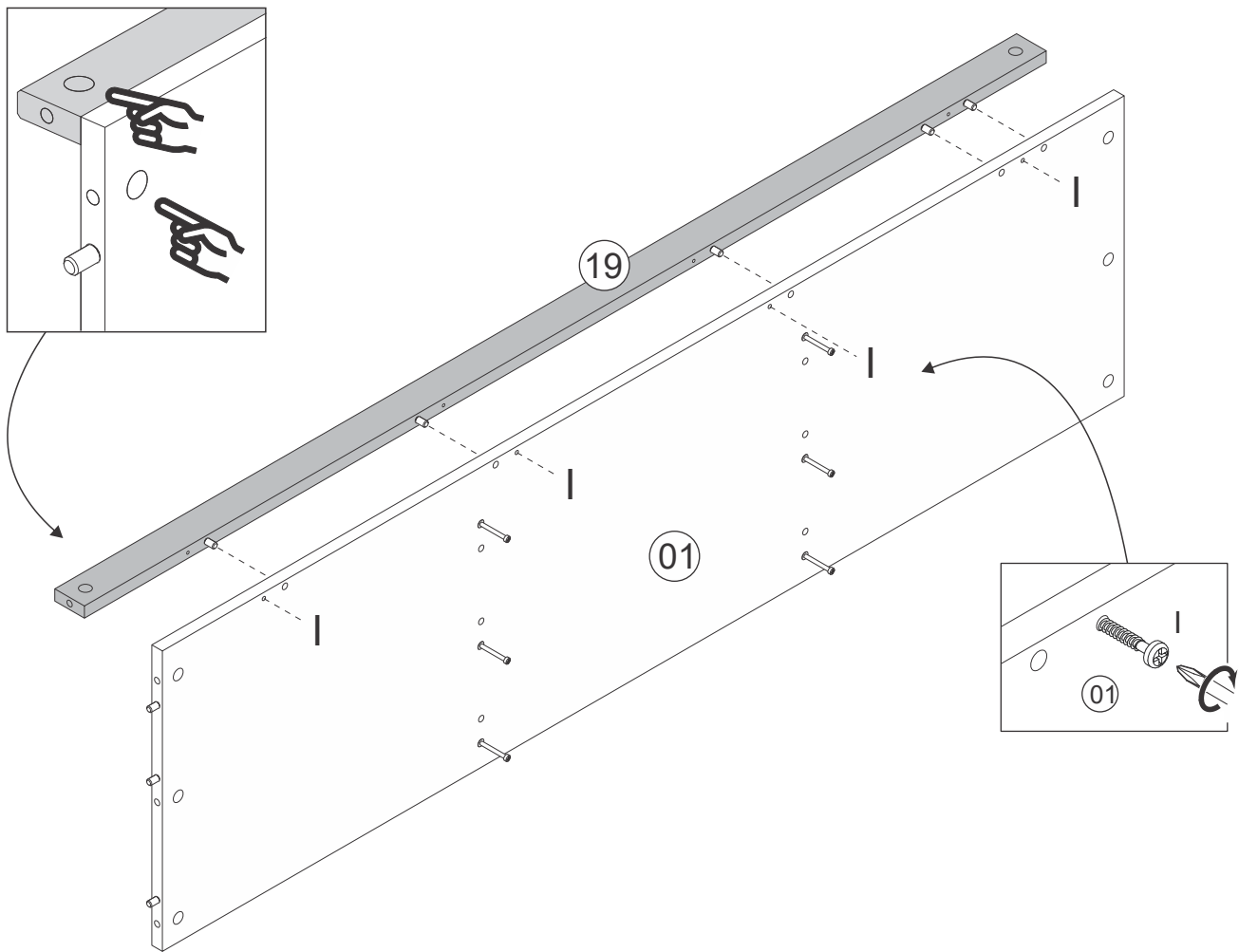
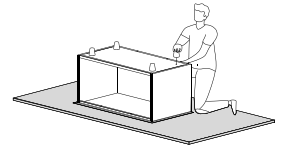

Once this step is completed, your product should look like this:

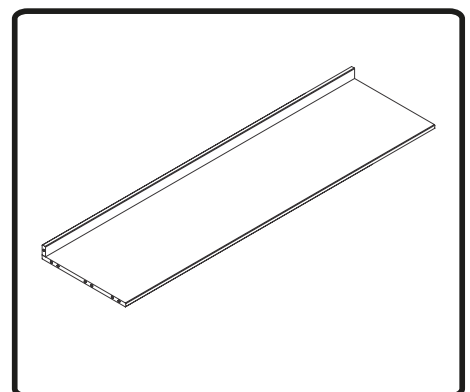

# Step 6

Secure the Small Division (18) to Top Panel (01). Insert Cam Locks (K) into Small Division (18), and tighten with a Phillips head screwdriver.

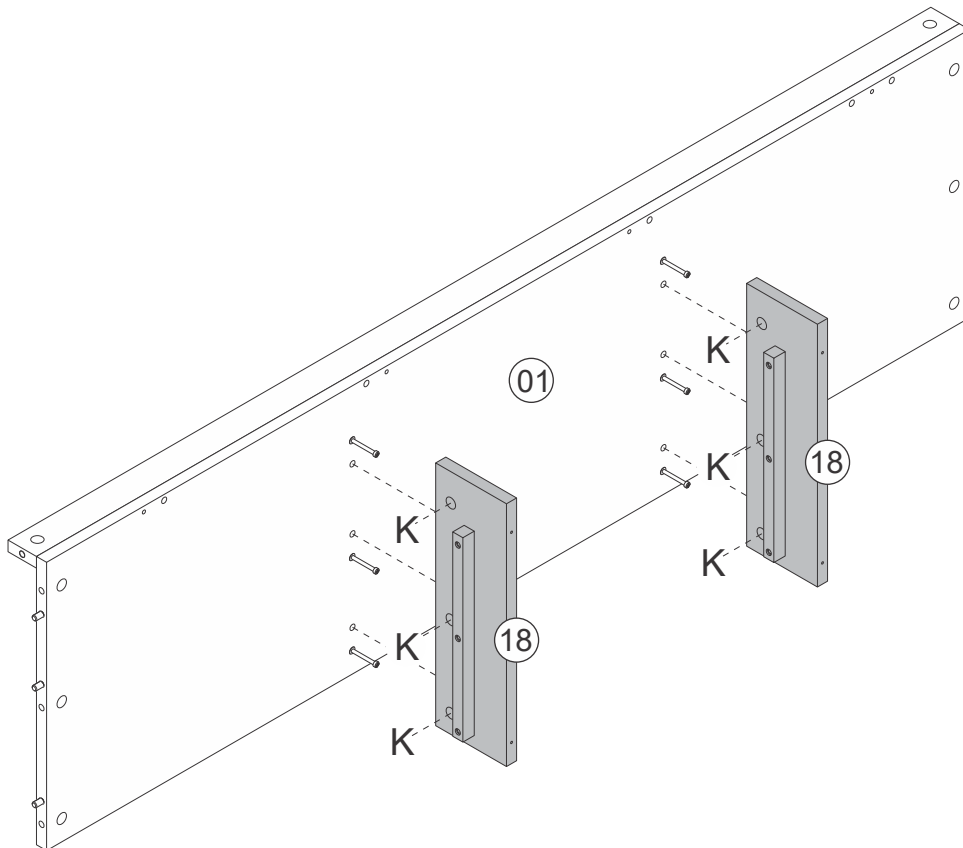
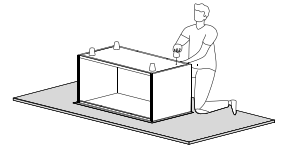

Once this step is completed, your product should look like this:

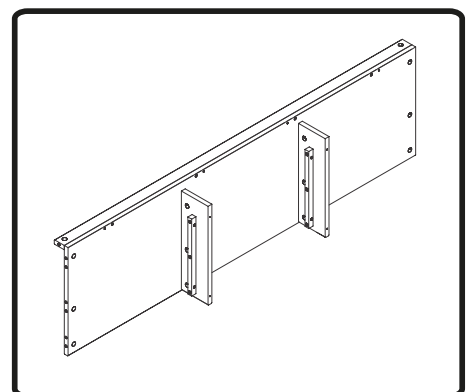

# Step 7

Secure the Large Front Rail (15) to Division (16) using Screw (E) and a Phillips head screwdriver. Pay attention to detail to assemble using the correct side.

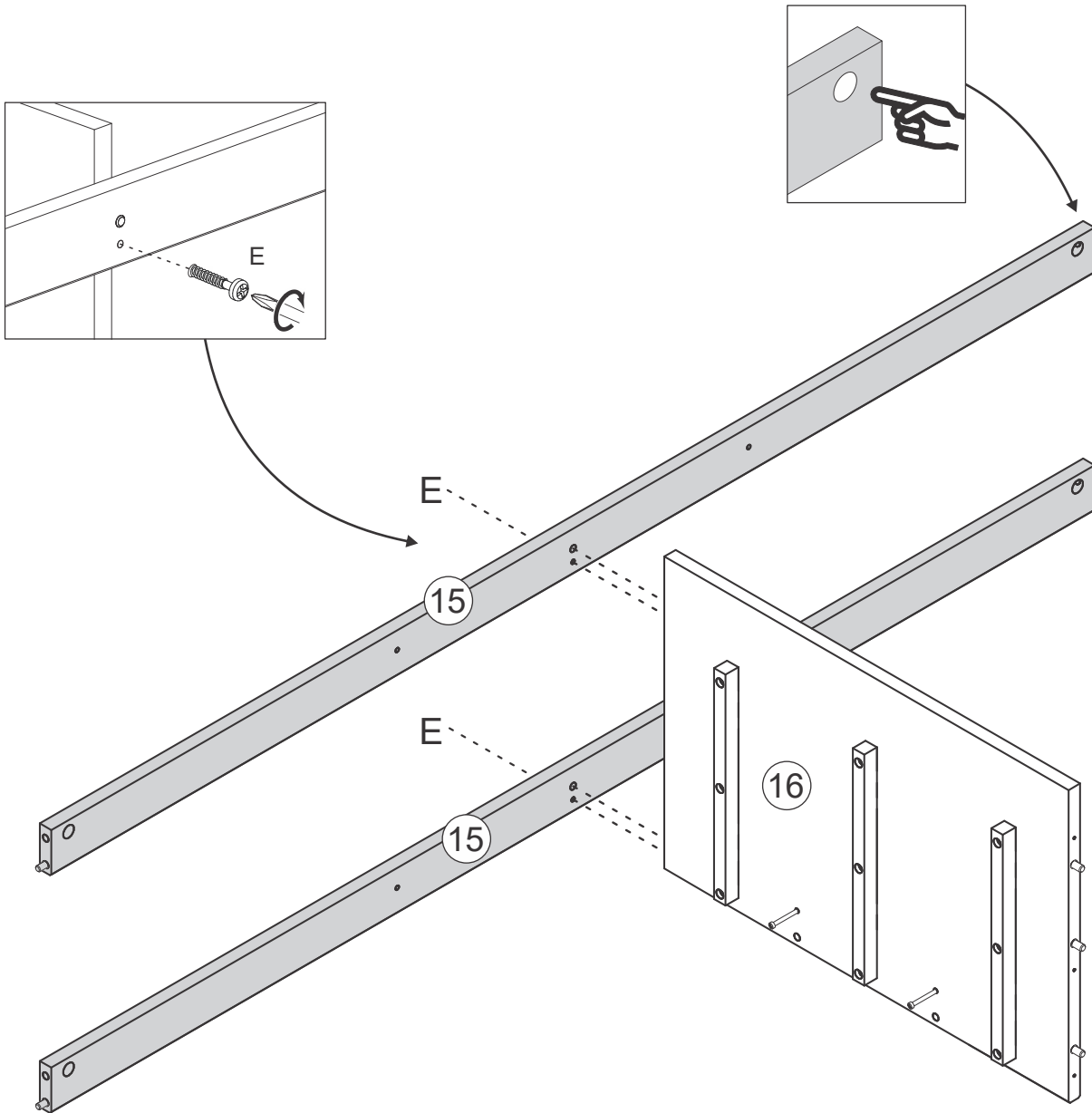
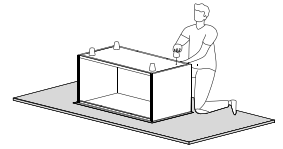

Once this step is completed, your product should look like this:

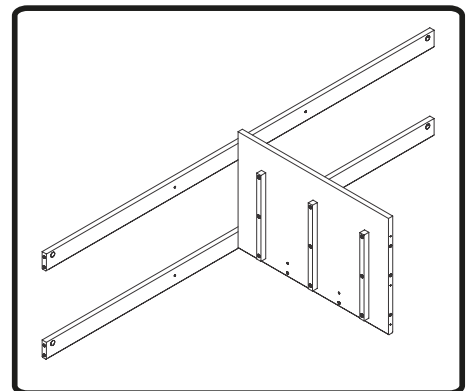

# Step 8

Secure the Large Front Rail (15) to Small Division (18) with Screw (E) and a Phillips head screwdriver.

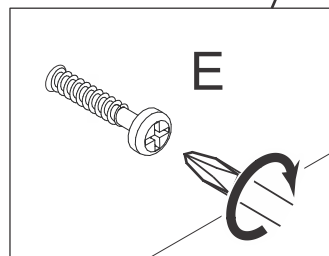
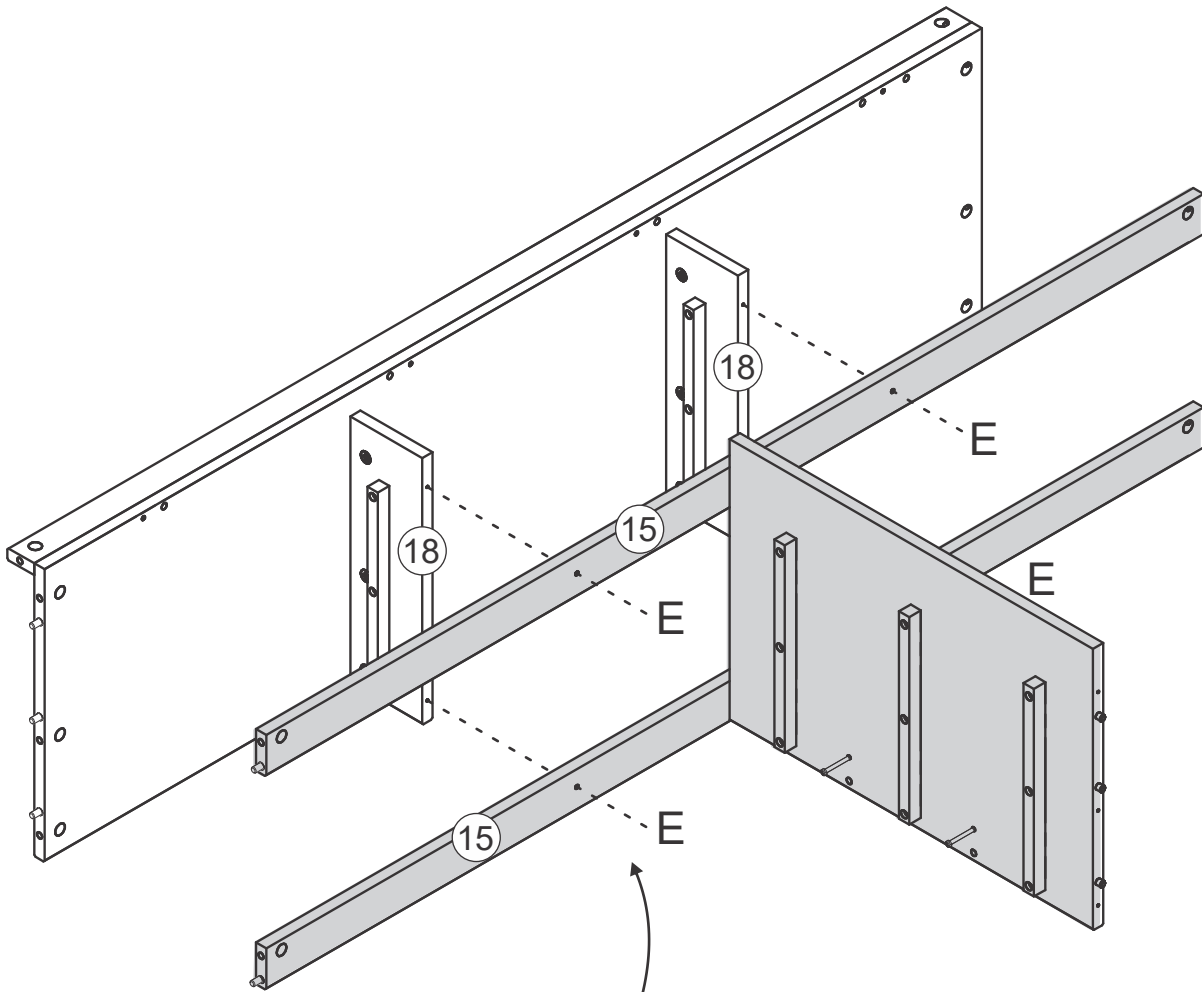
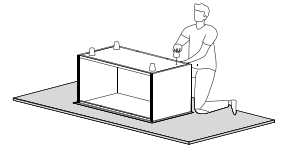

Once this step is completed, your product should look like this:

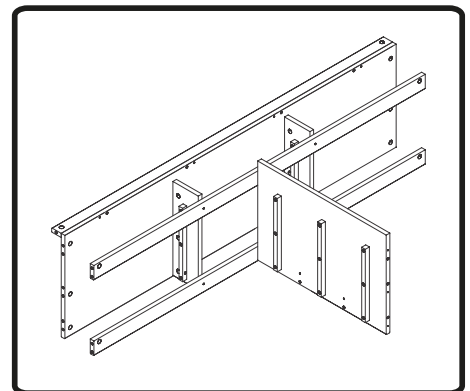

# Step 9

Secure the Front Rail (14) to Division (16). Insert cam locks (K) into Front Rail (14), and tighten with a Phillips head screwdriver.

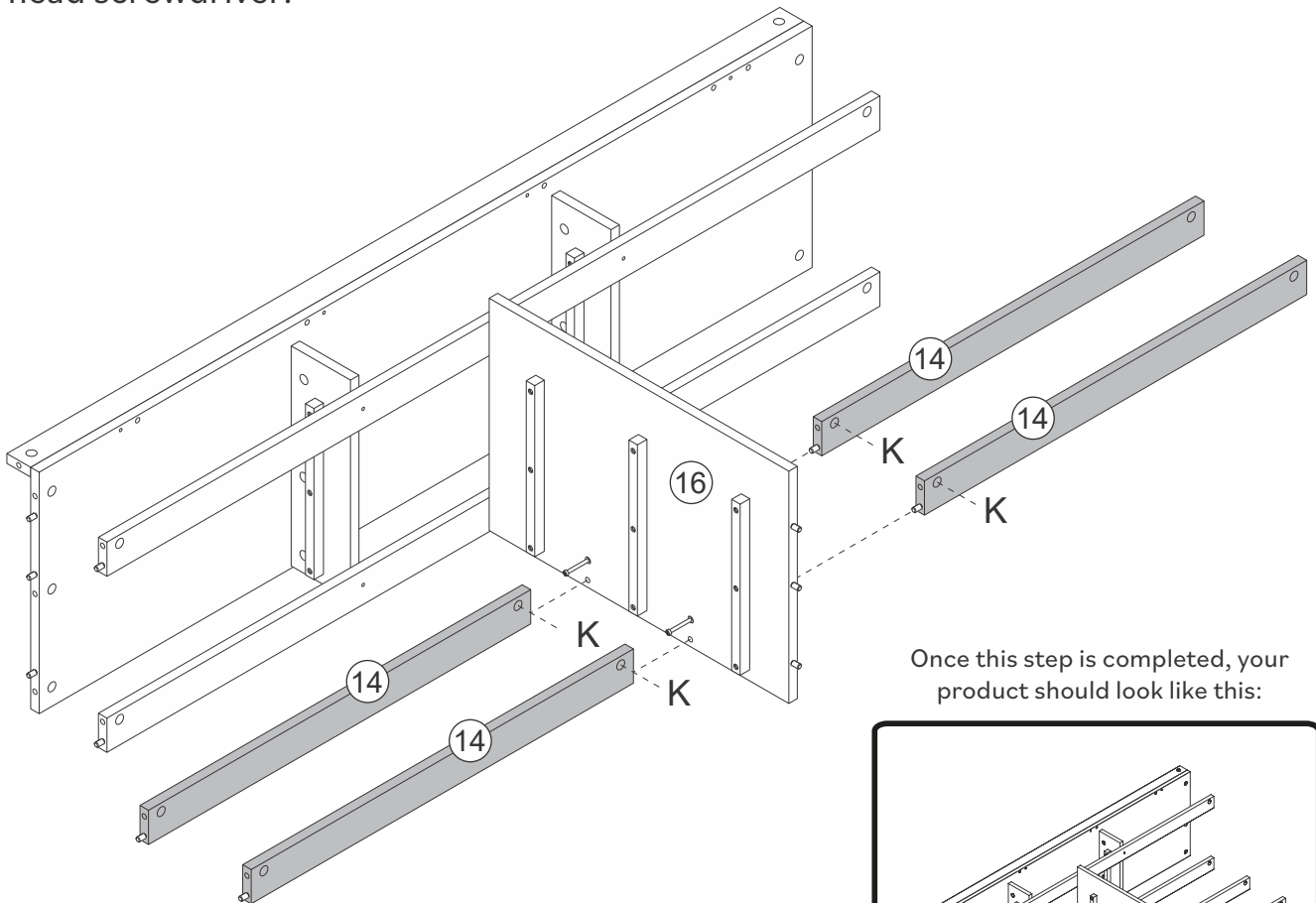
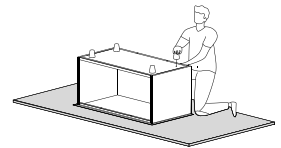

Once this step is completed, your product should look like this:

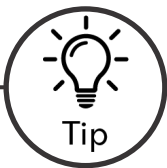
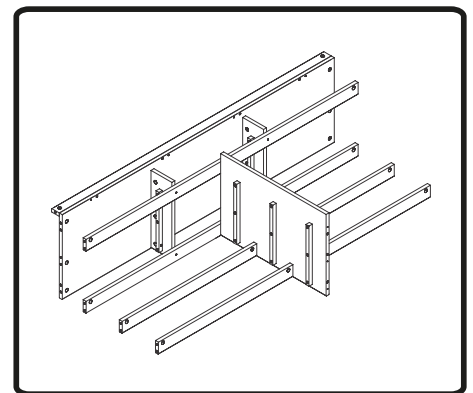

Tip

## Cam Locks

Cam Locks help securely join two pieces together. Follow these easy steps.

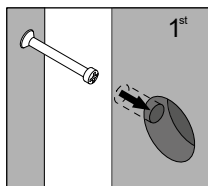

1: Insert Cam Bolt into bolt holes on the flat side. Don't over tighten!

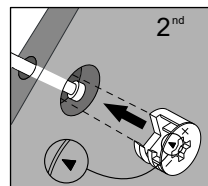

2: Assemble both parts together. The cam bolts goes in the drills holes that have a circular hole on the side, you should be able to see the cam bolt through it. After fitting parts together insert the cam lock on the side holes.

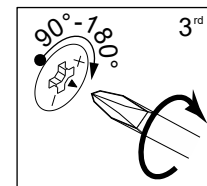

3: On the back of the Cam Lock will be a 'C' shape. Insert the Cam Lock so the opening of the 'C' fits over the Cam Bolt. Tighten with the screwdriver.

# Step 10

Secure the Top Panel (01), Front Rail (14), Large Front Rail (15) and Top Rail (19) to Left Side Panel (02).

Then insert cam locks (K) into Top Panel (01), Front Rail (14), Large Front Rail (15), Top Rail (19) and tighten with a Phillips head screwdriver.

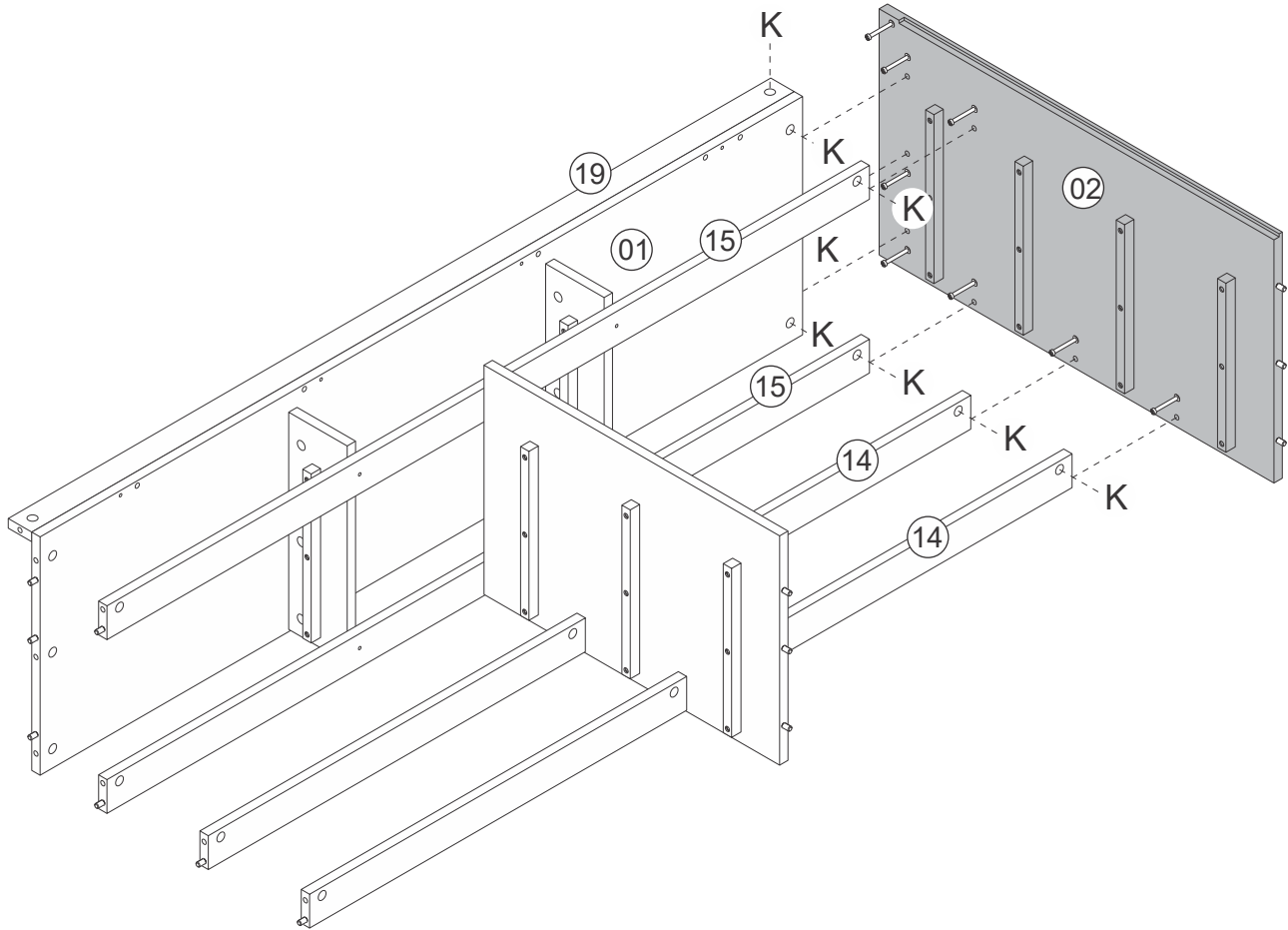
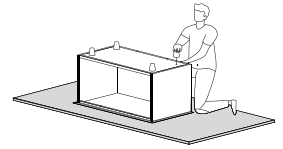

Once this step is completed, your product should look like this:

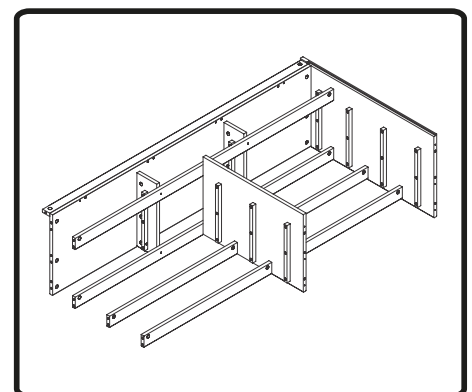

# Step 11

Do the same to assemble the Right Side Panel (03).

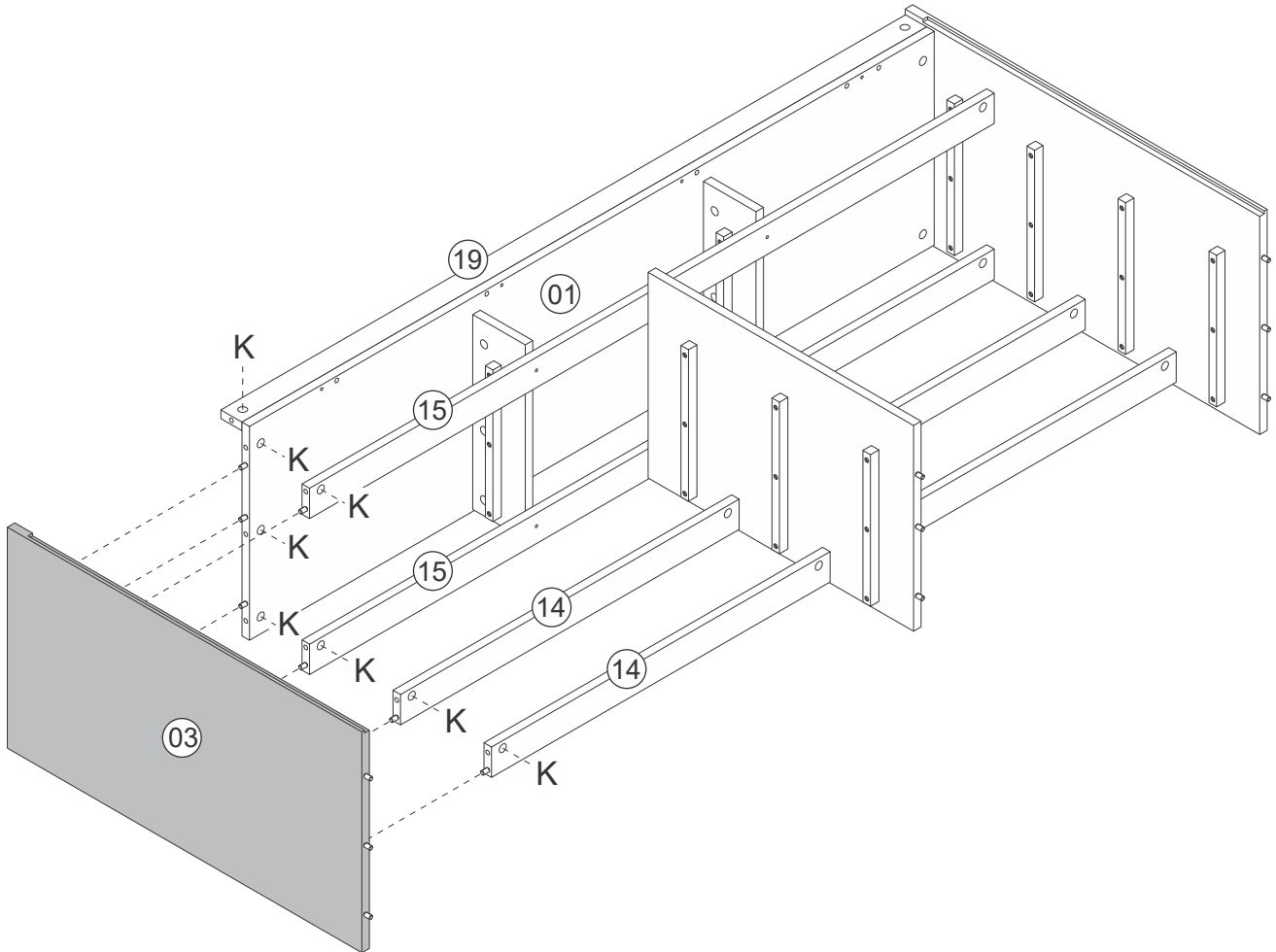
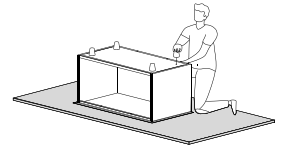

Once this step is completed, your product should look like this:

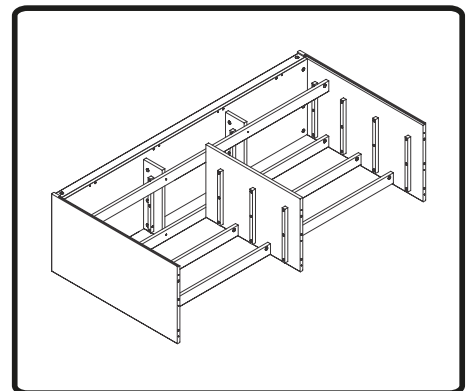

# Step 12

To assemble the bottom start by attaching the Central Foot (22) to Base (04) with Bolt (L) and Hex key (N).

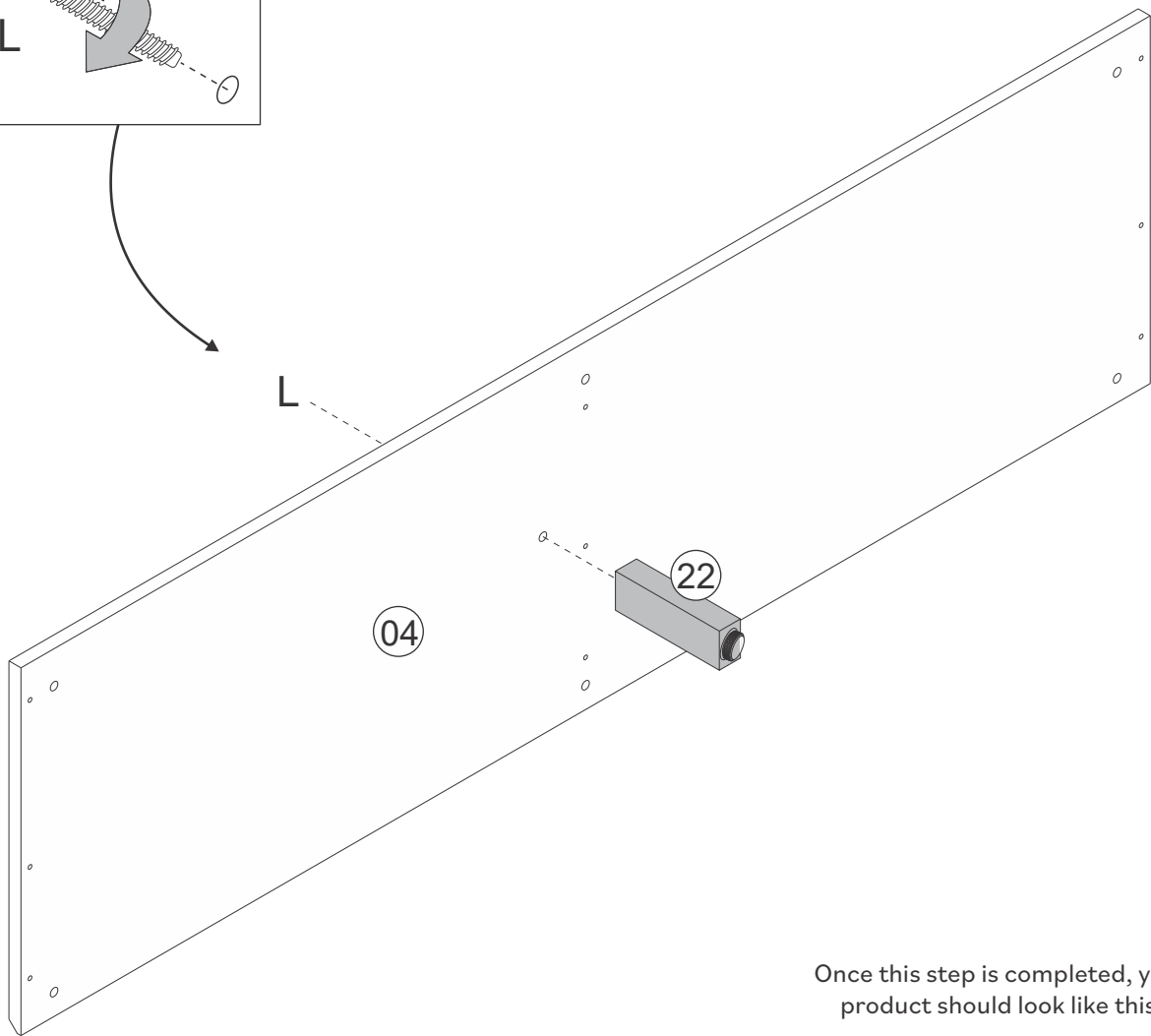
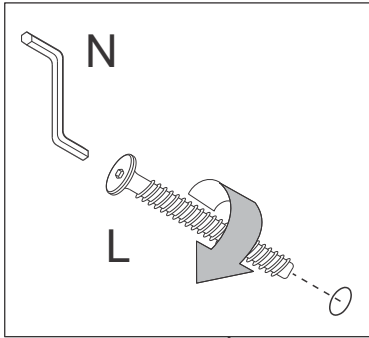
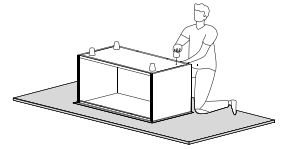

Once this step is completed, your product should look like this:

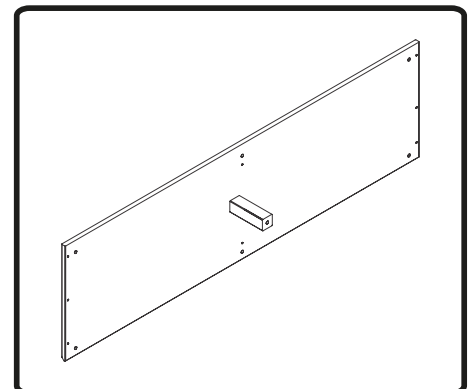
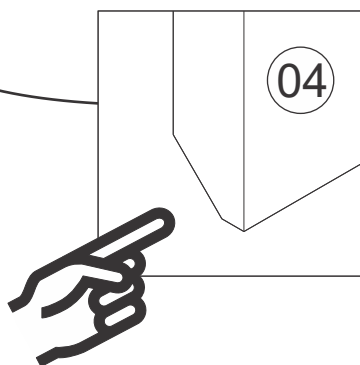



# Step 13

Secure the Base (04) to the Left Side Panel (02), Right Side Panel (03) and Division (16) with Screw (E) and Phillips head screwdriver. Pay careful attention to the angle in Base (4). The narrow side of the angle should be facing inward.

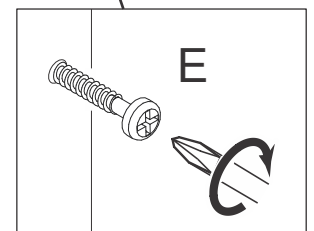
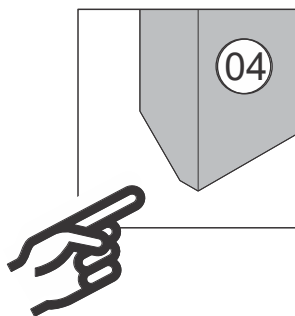
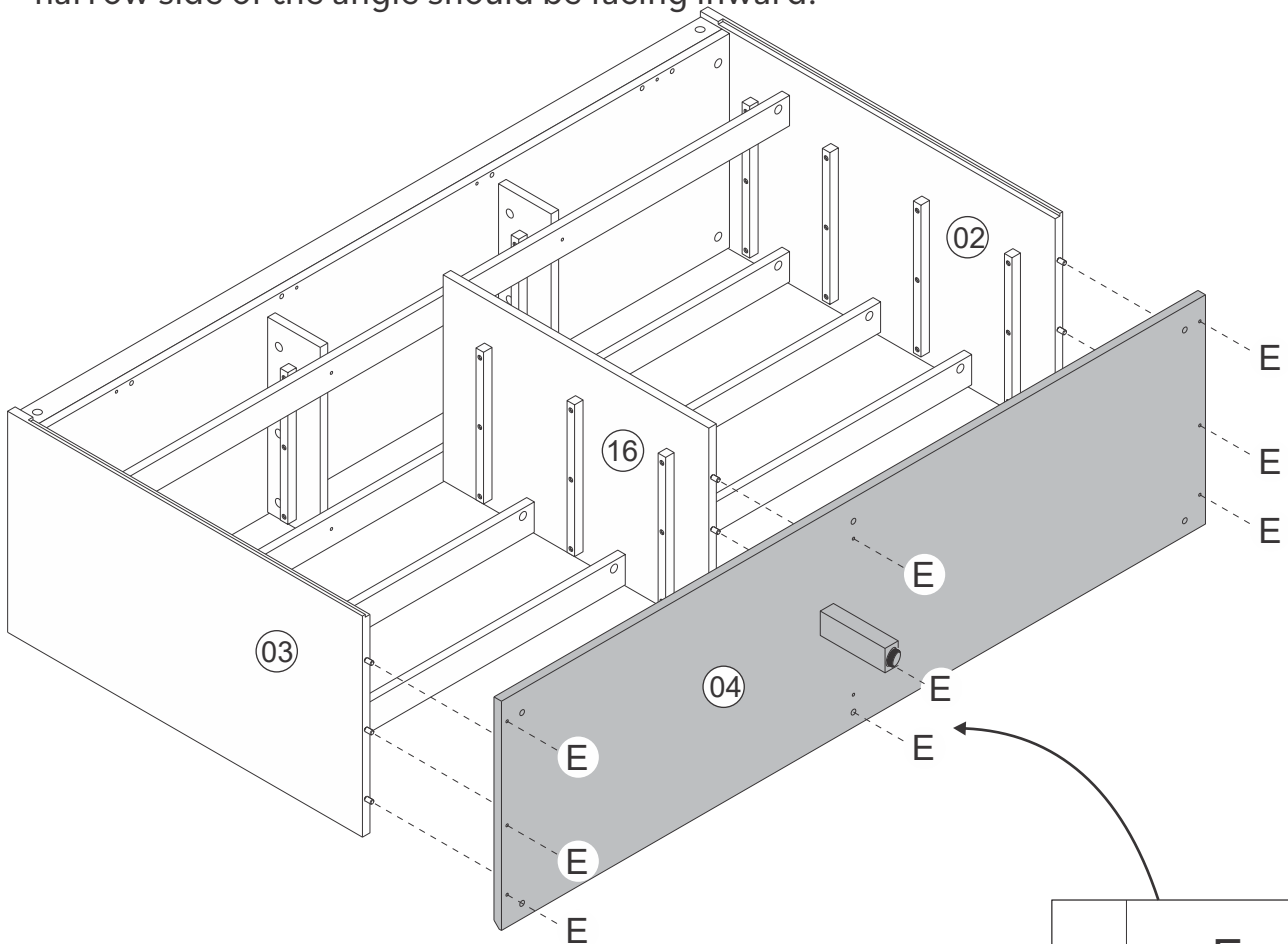
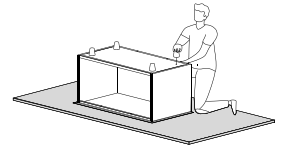

Once this step is completed, your product should look like this:

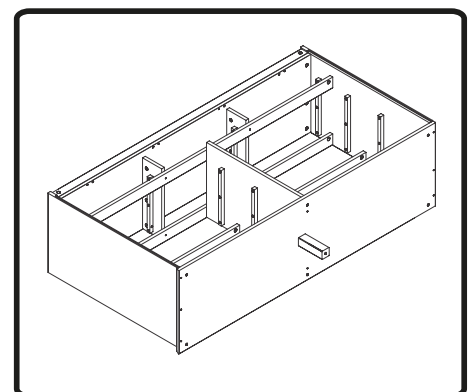

# Step 14

Secure the Bottom Front Rail (34) to Foot (36) with Screw (E) and a Phillips head screwdriver.

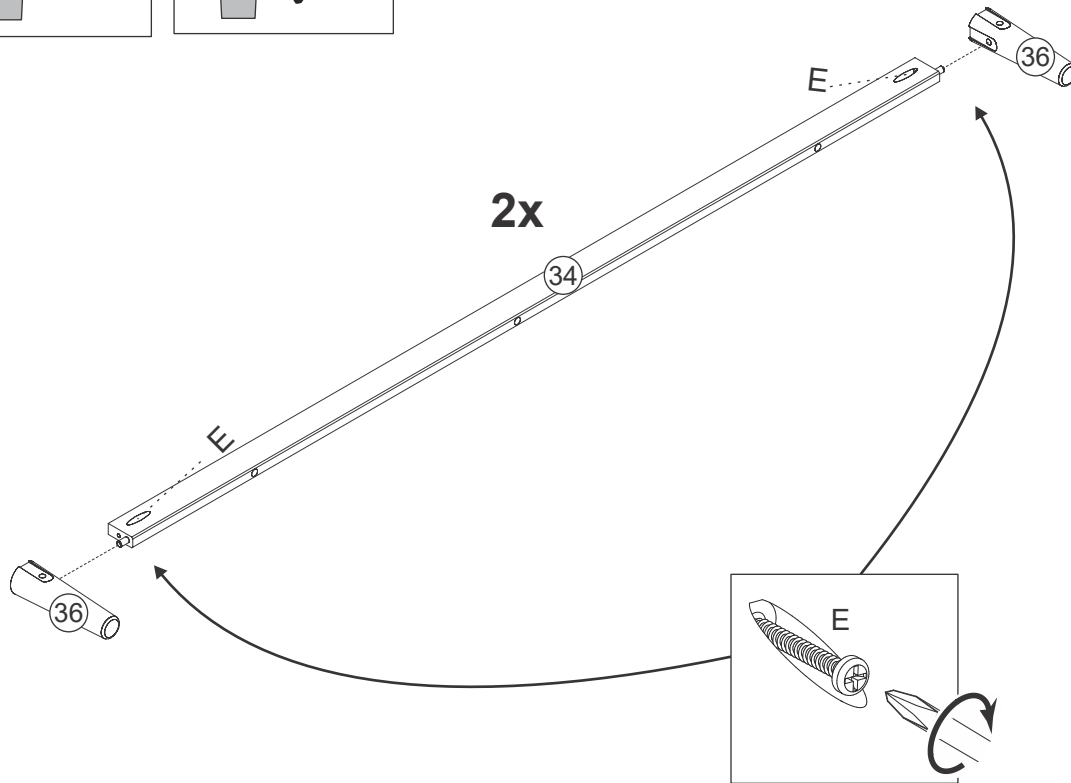
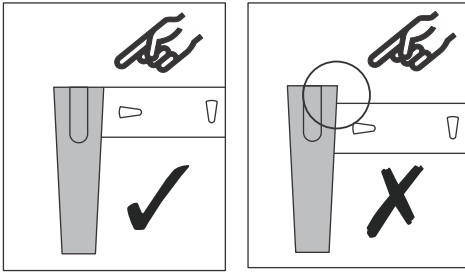
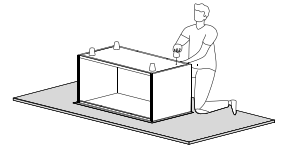

Once this step is completed, your product should look like this:

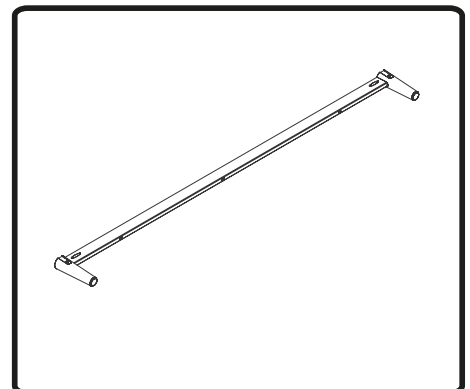

# Step 15

Secure Foot (36) to Bottom Side Rail (35), with Screw (E) and a Phillips head screwdriver.

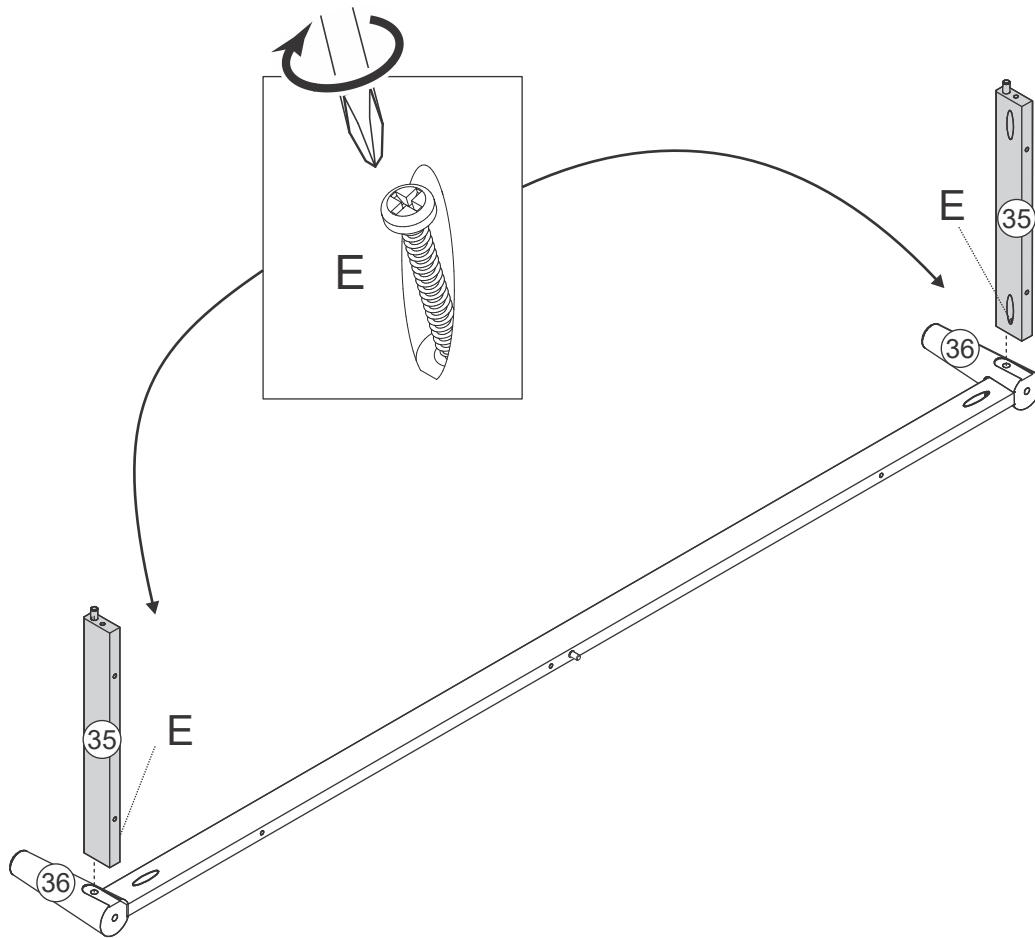
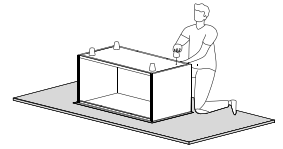

Once this step is completed, your product should look like this:

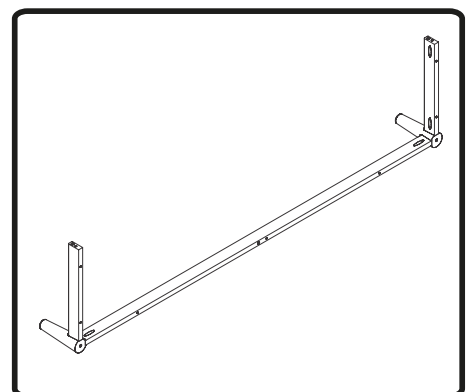

# Step 16

Secure the other Foot (36) to Bottom Side Panel (35) with Screw (E) and a Phillips head screwdriver.

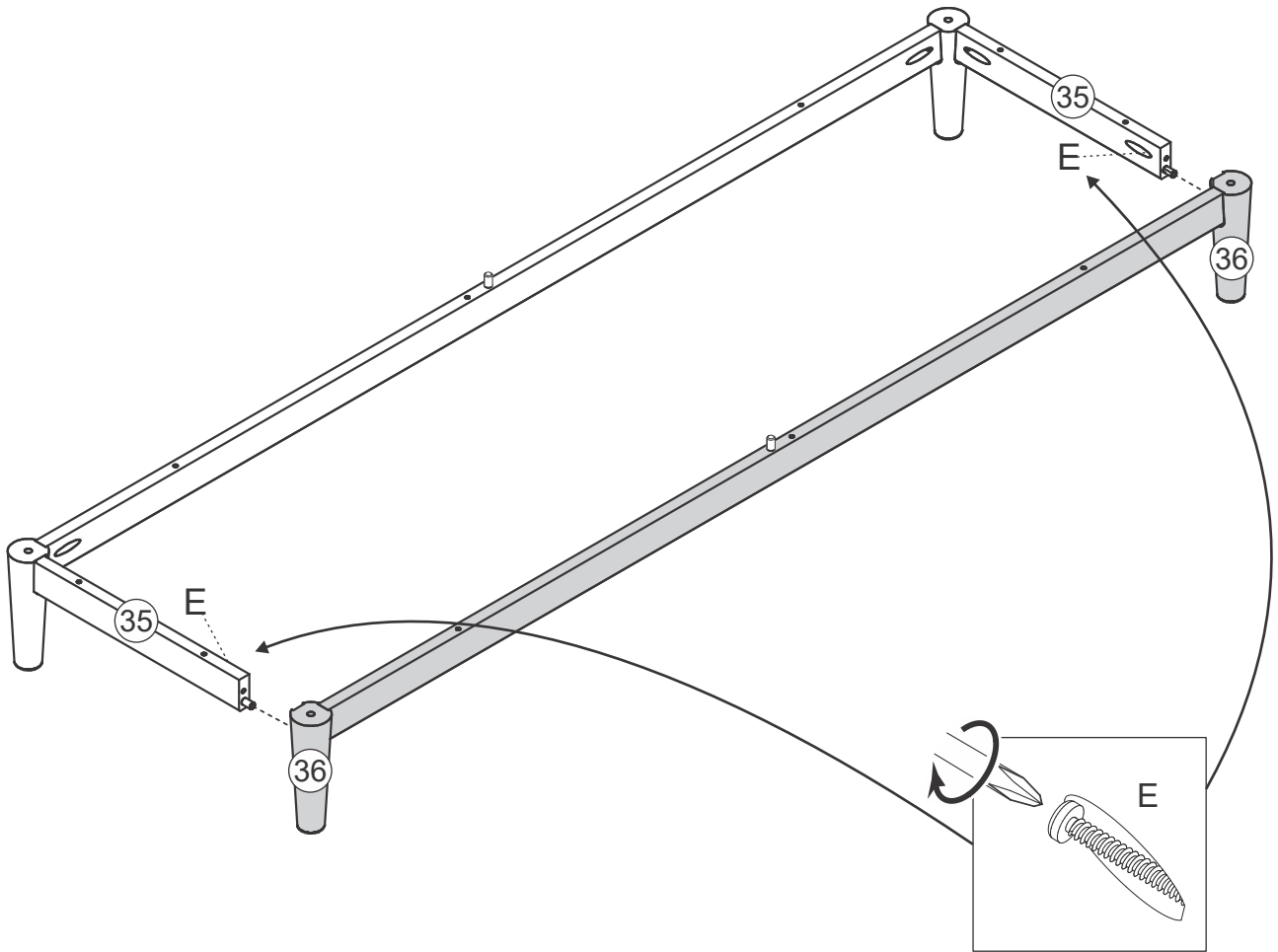
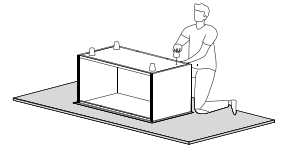

Once this step is completed, your product should look like this:

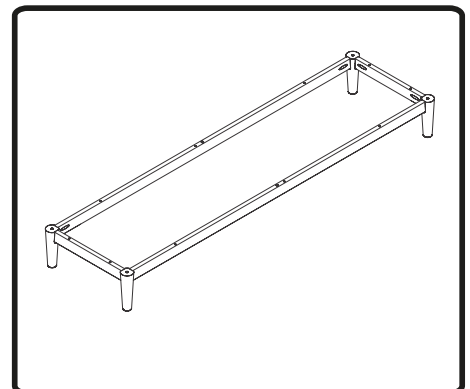

# Step 17

Secure Bottom Front Rail (34) and Bottom Side Rail (35) to Base (04) using Screw (E) and a Phillips head screwdriver.

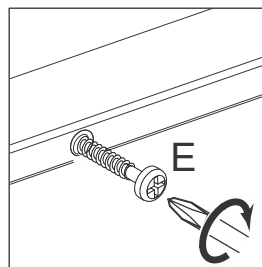
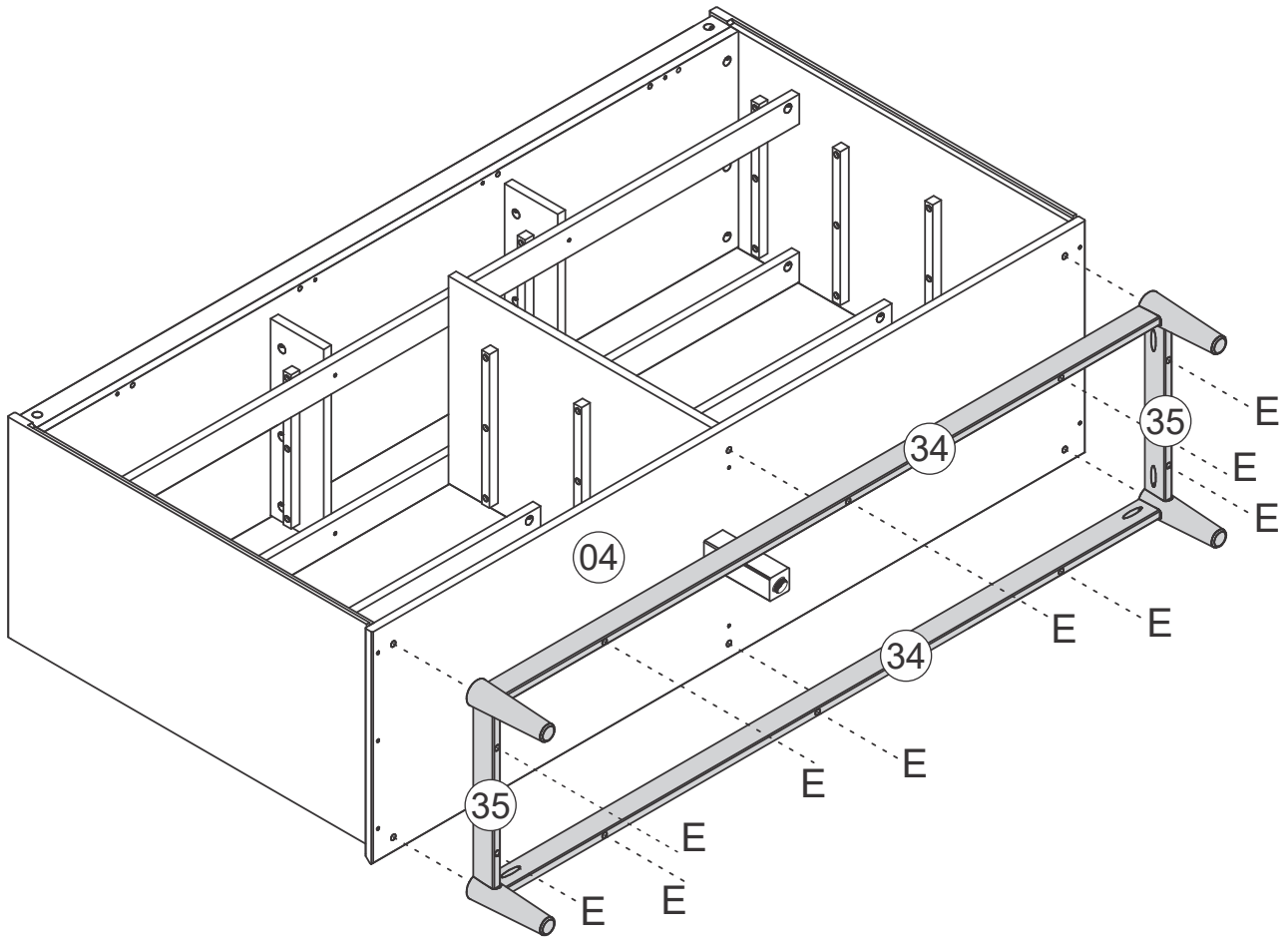
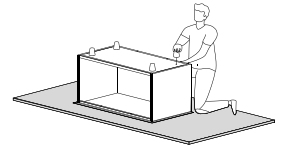

Once this step is completed, your product should look like this:

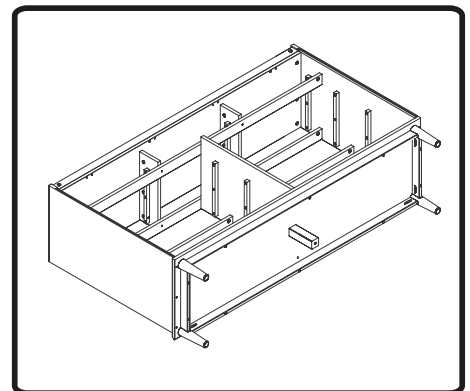

# Step 18

Attach the Bottom Back Panel (21) to Left Side Panel (02) and Right Side Panel (03) with Screw (D) and a Phillips screwdriver. Also attach to the Division (16) with Screw (I) and a Phillips head screwdriver.

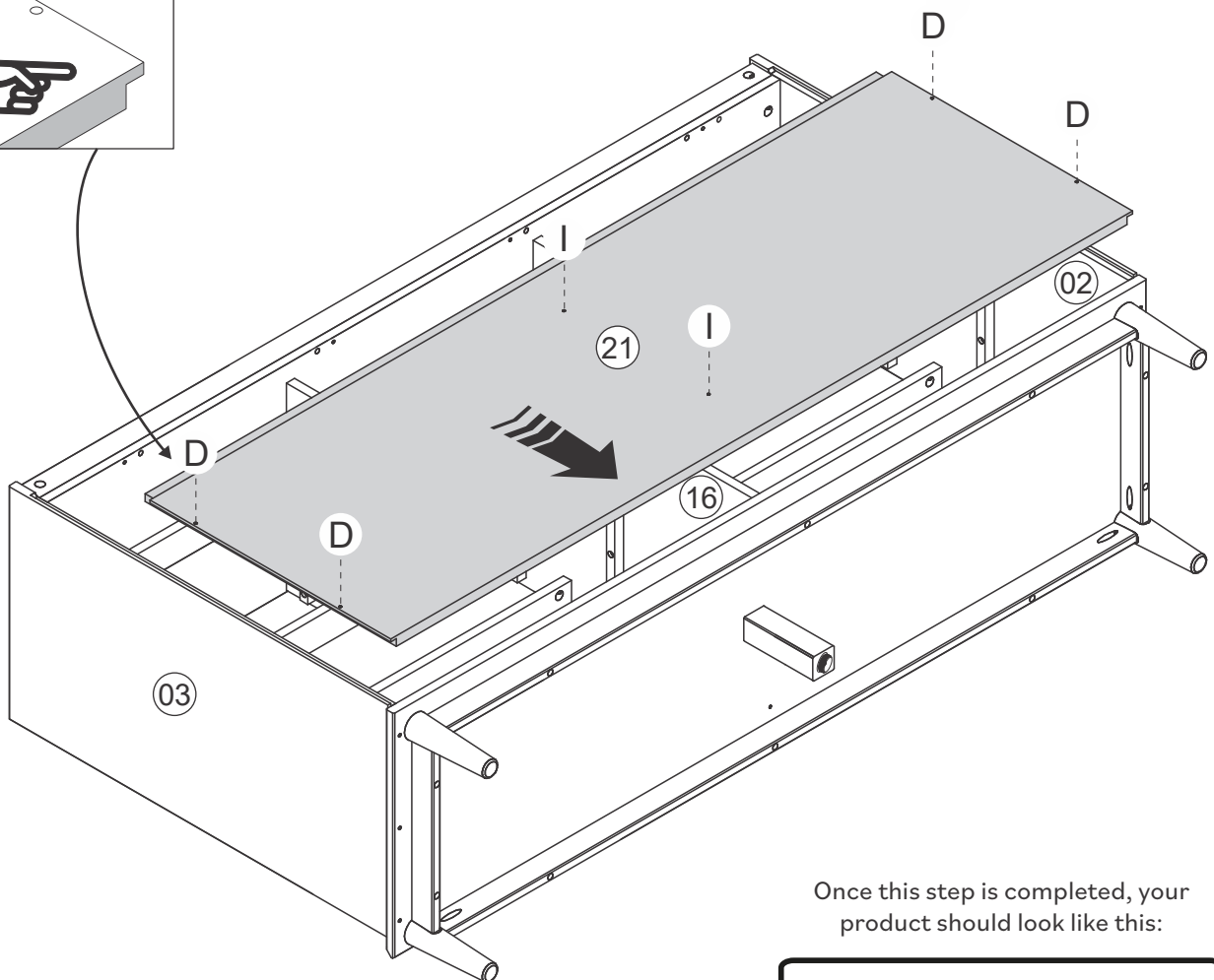
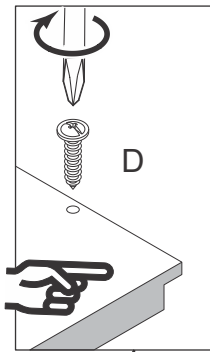
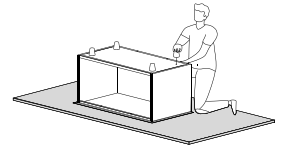

Once this step is completed, your product should look like this:

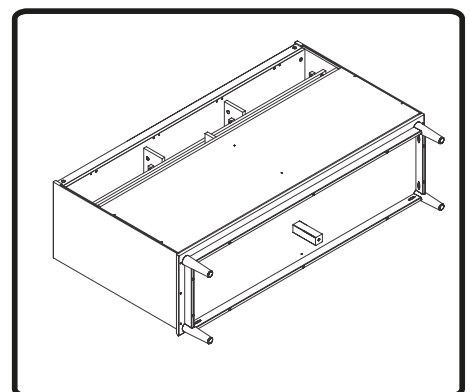

# Step 19

Secure Back Panel (20) using Nails (M) and a hammer.

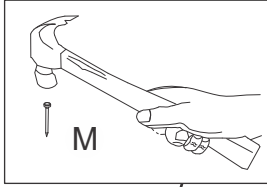
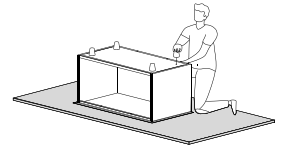

Name and address of the supplier and date of production

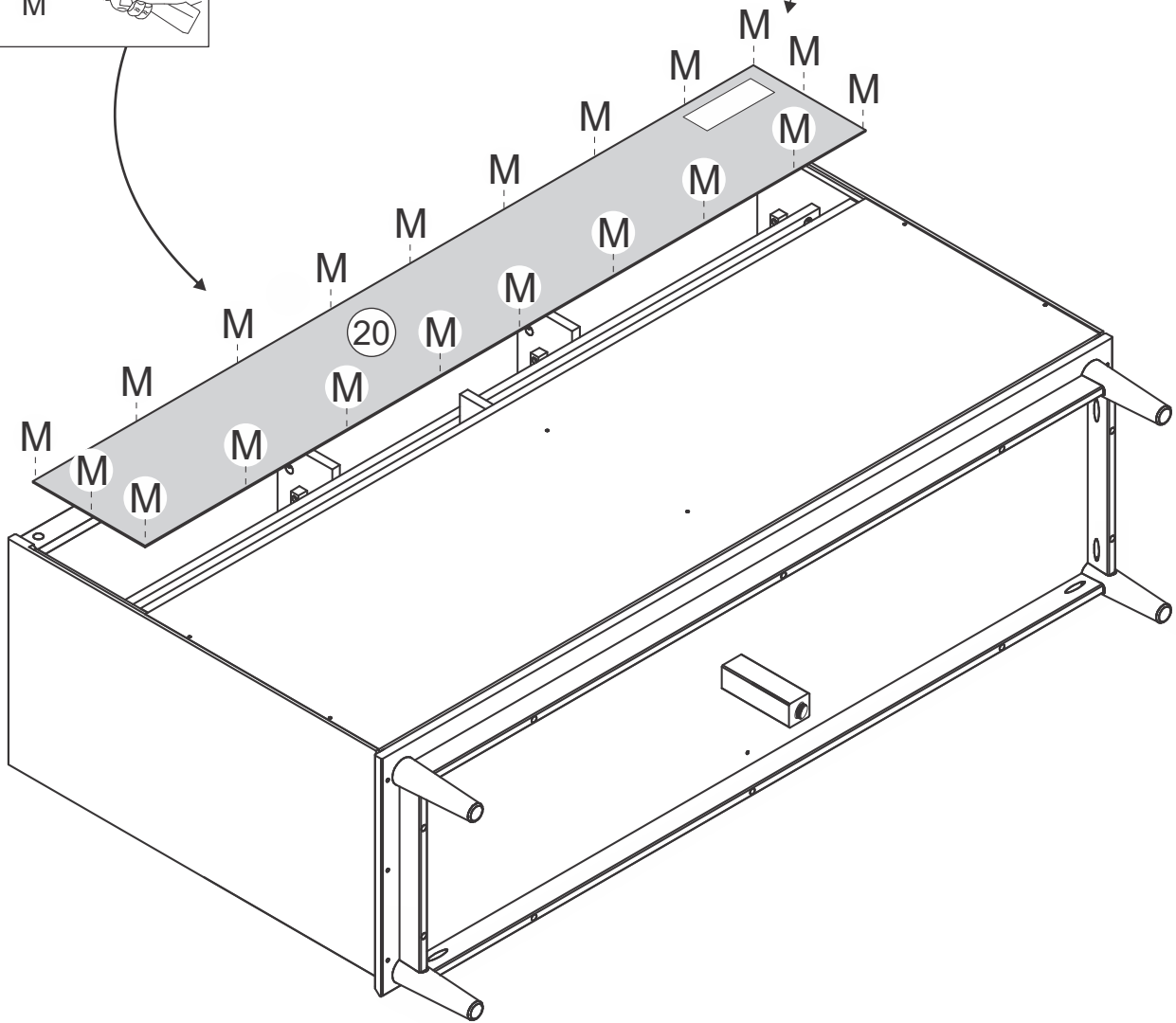

Once this step is completed, your product should look like this:

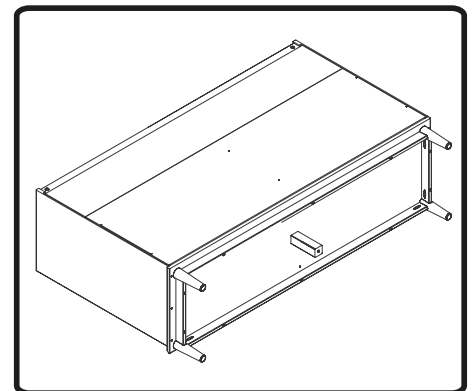

# Step 20

Secure Left Drawer Side (05) and Right Drawer Side (06) to Drawer Front (08) using Cam Bolts (K) and a Phillips head screwdriver.

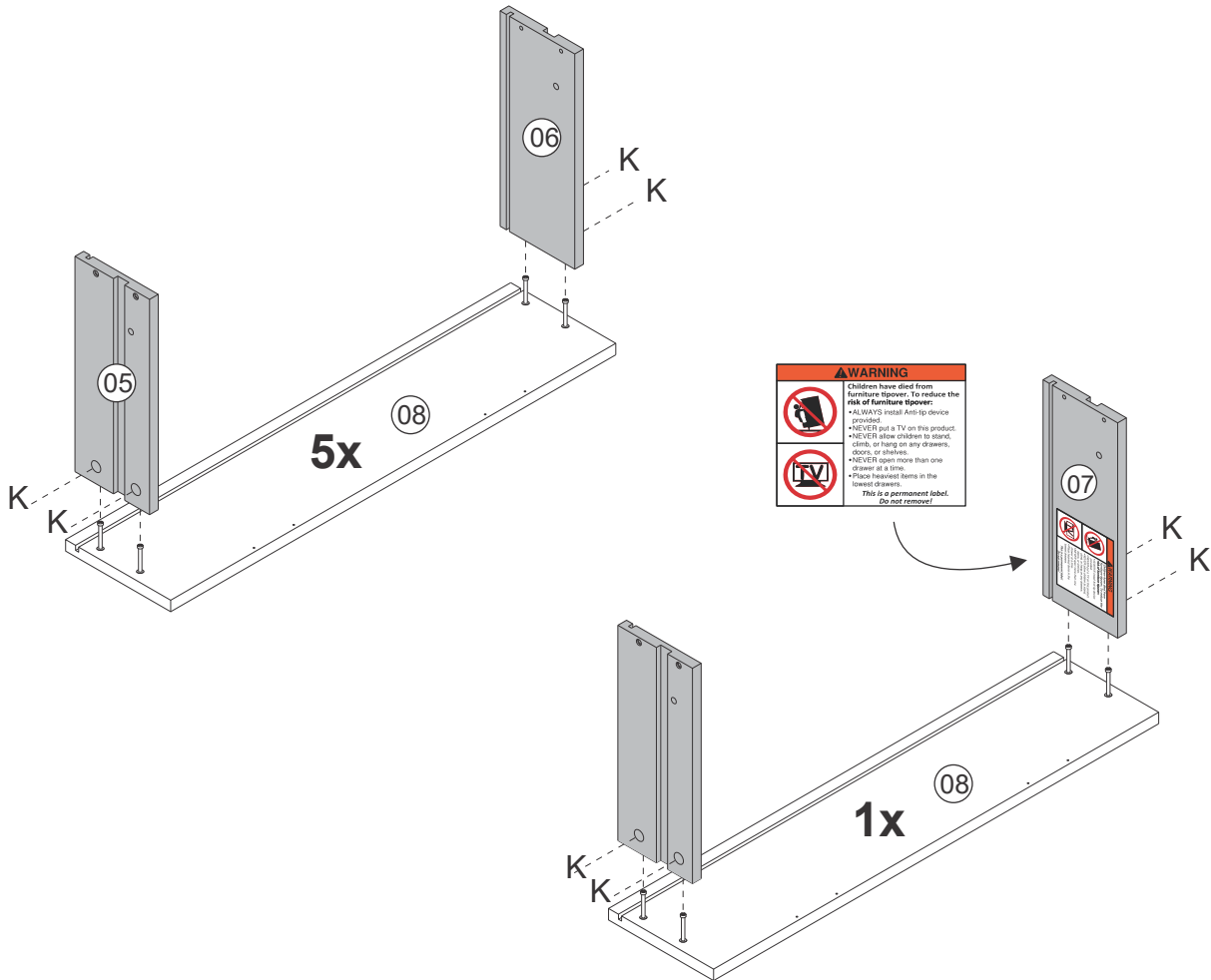
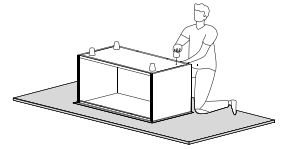

Once this step is completed, your product should look like this:

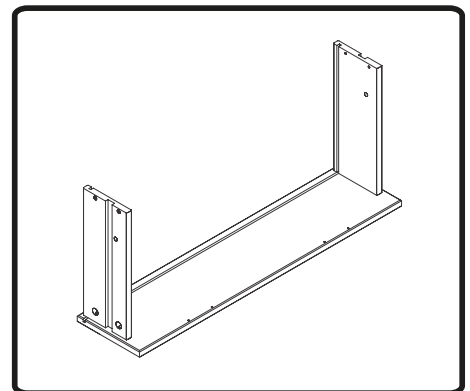



# Step 21

Slide Drawer Bottom (09) on the grooves on Left Drawer Side (05) and Right Drawer Side (06) fitting in Drawer Front (08).

Secure Drawer Back (10) with Screw (I) and a Phillips head screwdriver.

One drawer will use Right Side (Warning) (07), this should be the top right drawer.

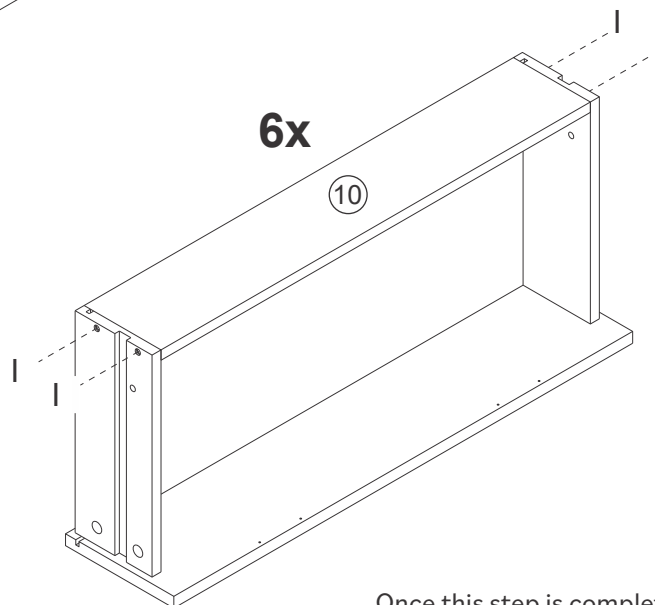
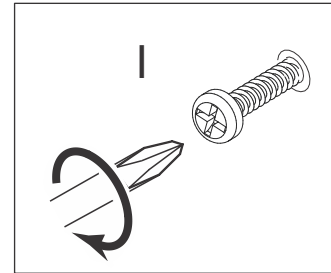
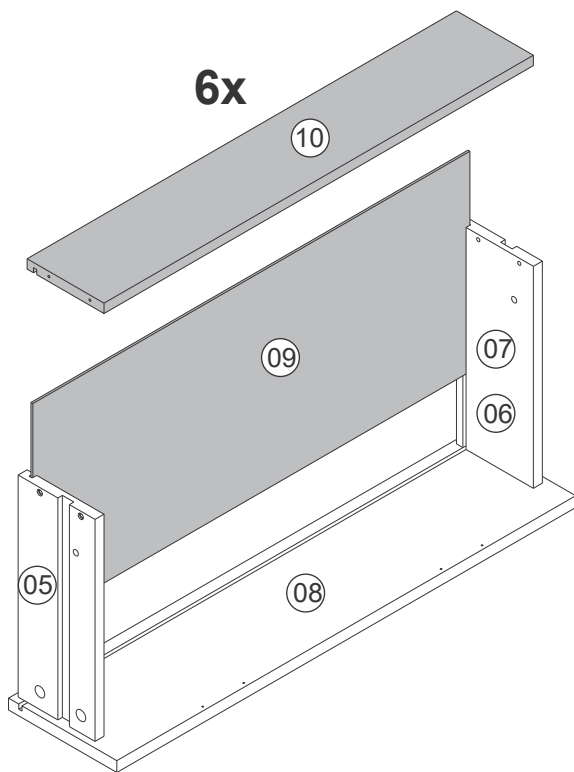
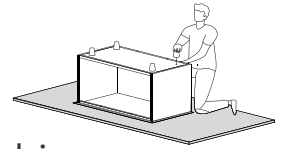

Once this step is completed, your product should look like this:

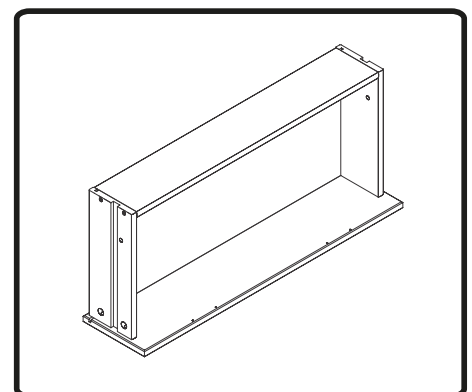

# Step 22

Secure Handle (Q) with Screw (C) and a Phillips head screwdriver in the pre-drilled holes on the Drawer Front (08).

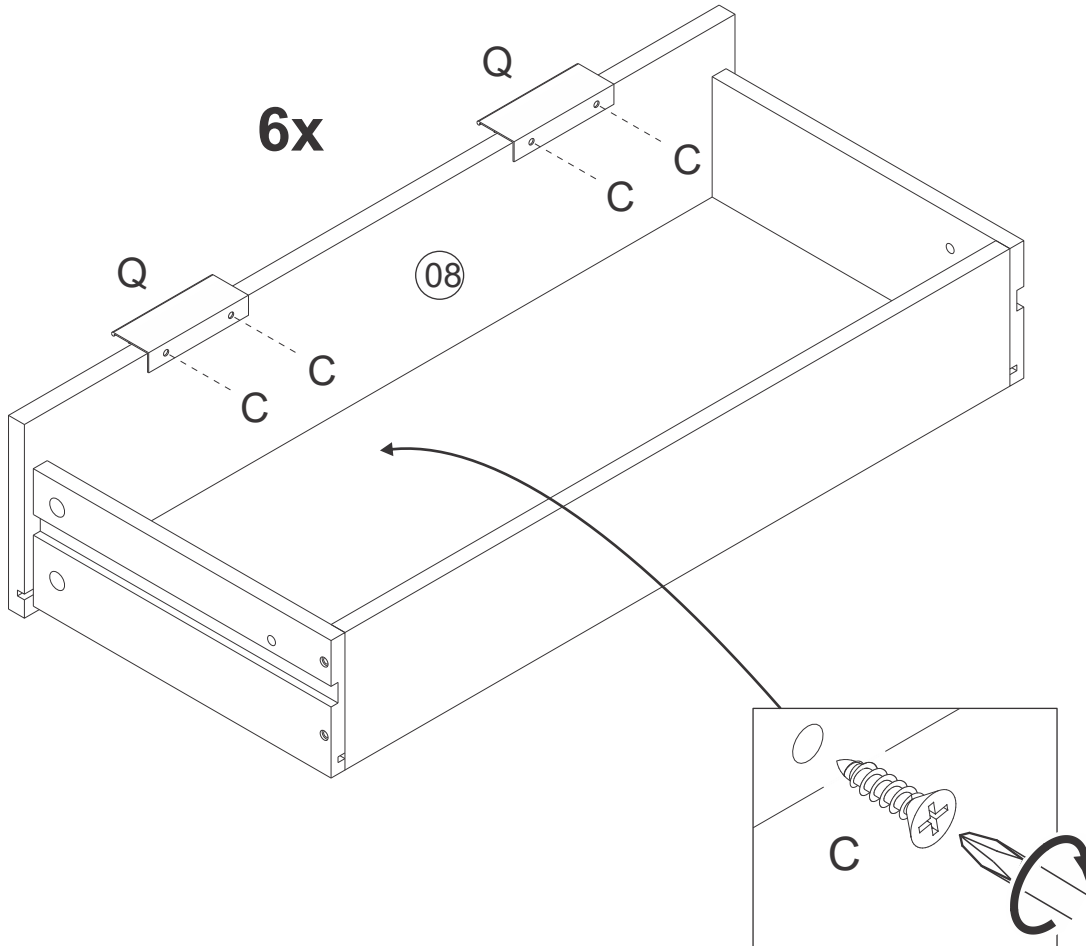
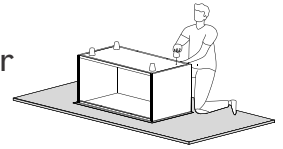

# Step 23

Assemble the small drawers as you did to the big ones, use Small Left Drawer Side (46), Small Right Drawer Side (47), Small Drawer Front (23), Small Drawer Bottom (48), Small Drawer Back (45) and Screw (I) with a Phillips head screwdriver.

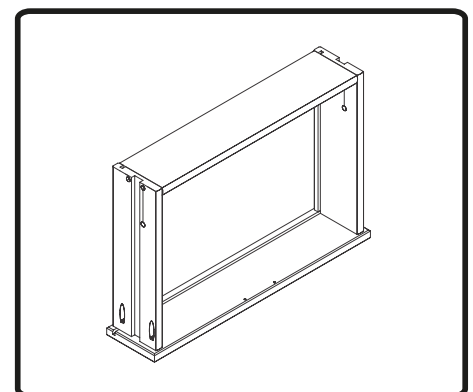
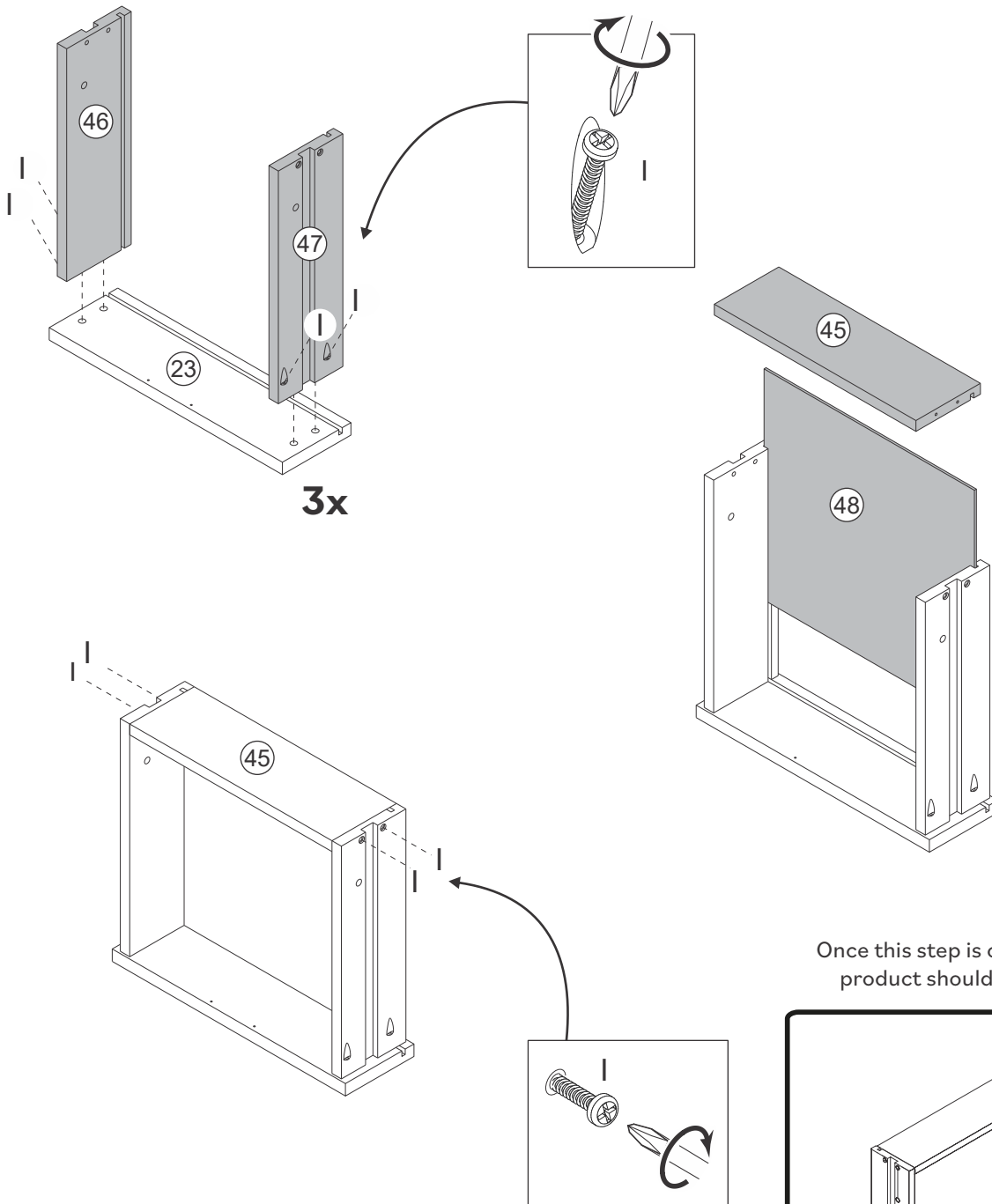
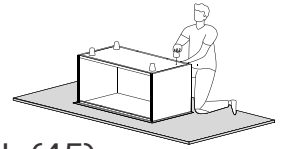

# Step 24

Secure Handle (Q) with Screw (C) and a Phillips head screwdriver in the pre-drilled holes on the Small Drawer Front (23).

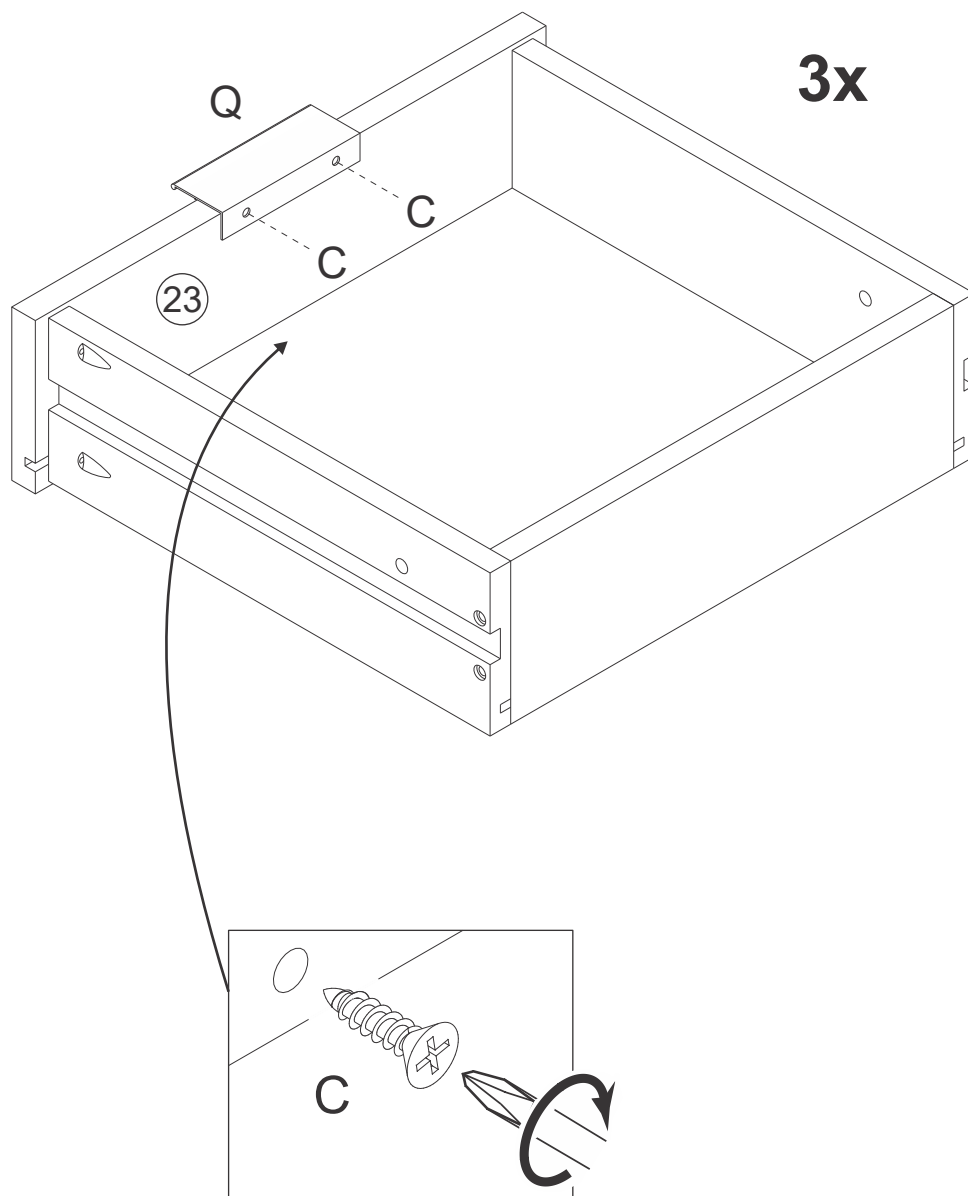
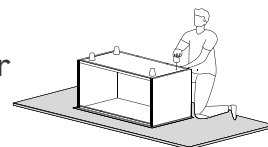

# Step 25

Insert Wooden dowel (A) into the Wood Slider (17), this will be the drawer stop.

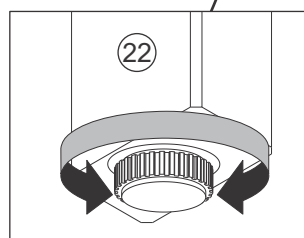
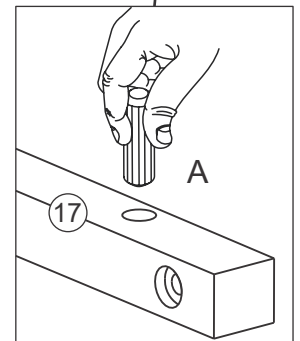
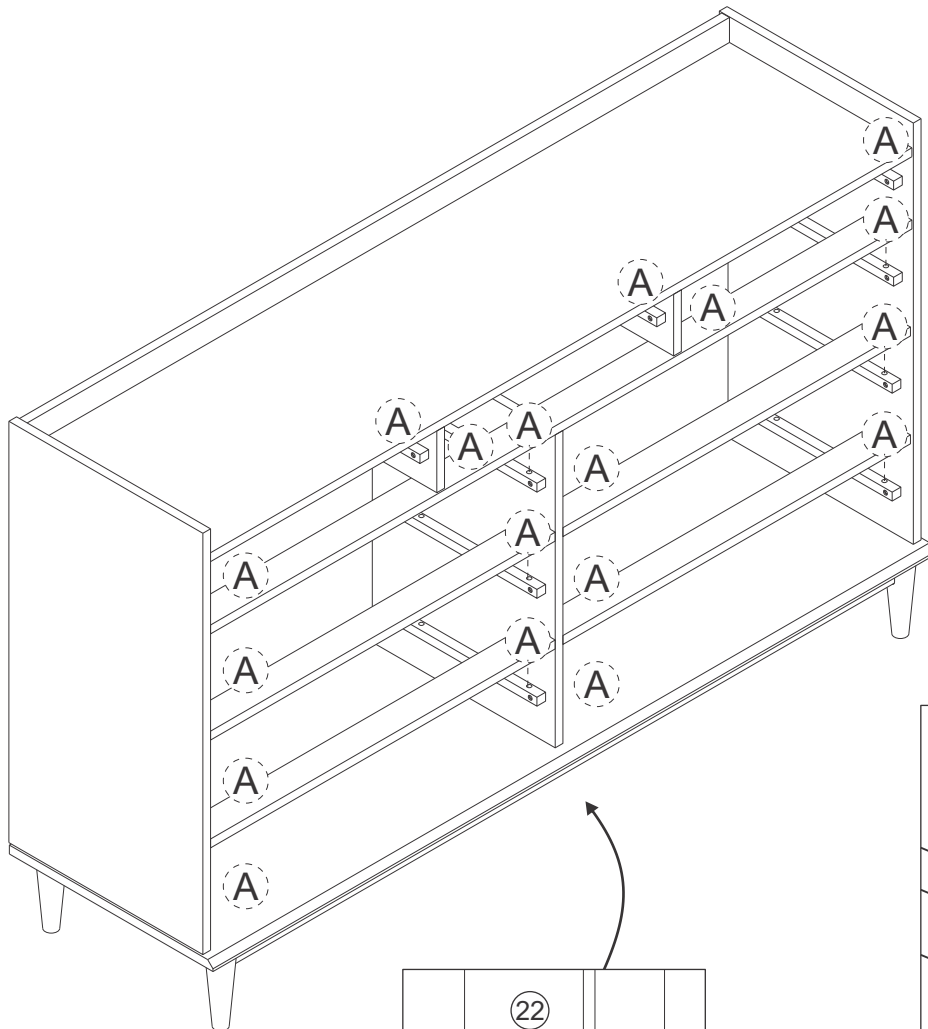
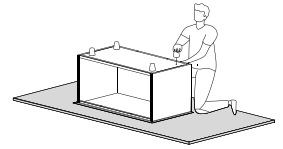

# Step 26

Insert drawers into the unit until you have passed the wooden dowel on the drawer slide. Then, insert Wooden Dowels (B) into the dowel holes inside of each drawer. Do not push dowels through all the way. Leave part of the dowel sticking out inside the drawer in case you need to remove the drawer.

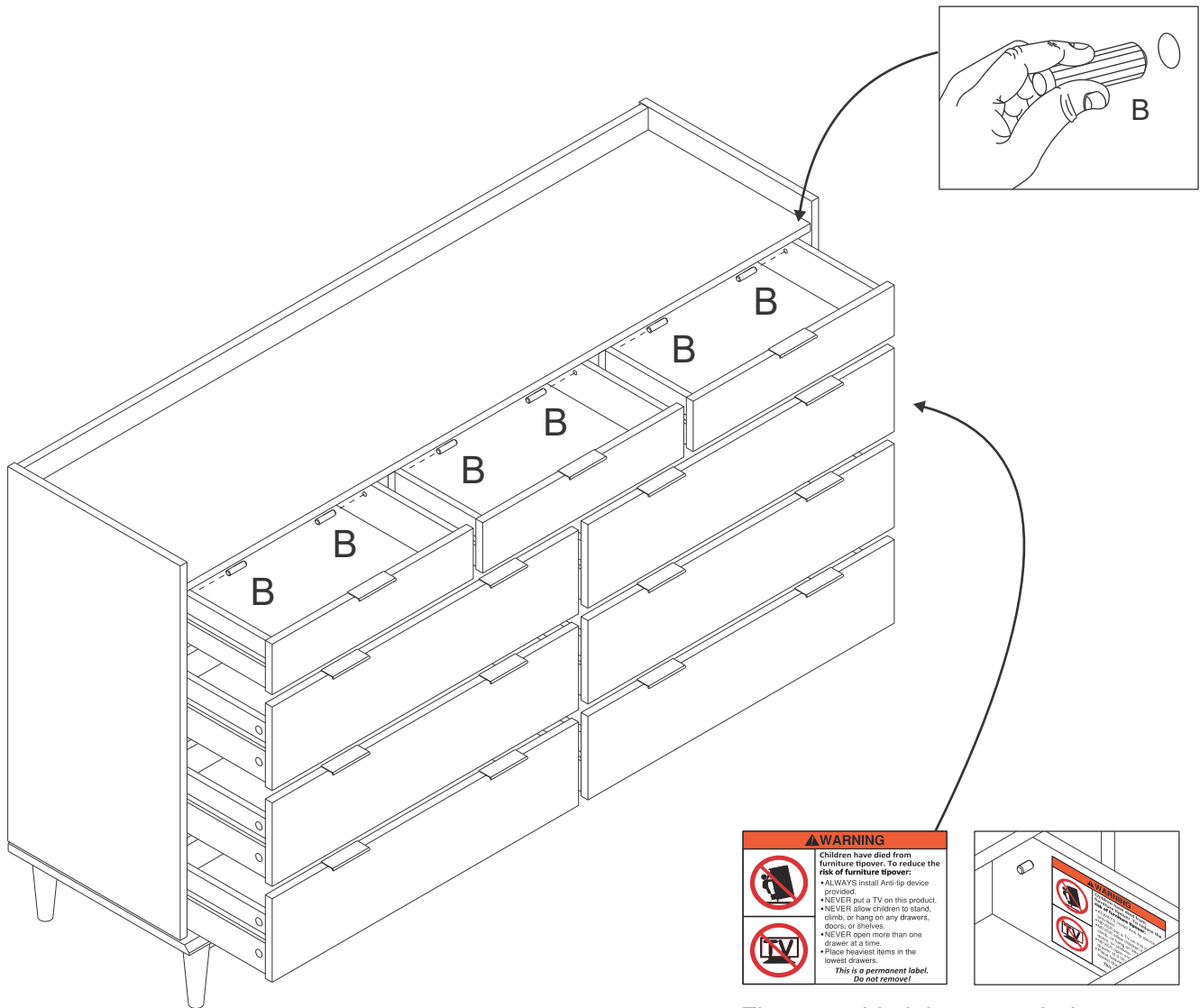
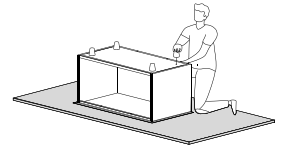

**WARNING**

Children have died from furniture tipover. To reduce the risk of furniture tipover:

- ALWAYS install Anti-tip device provided.
- NEVER put a TV on this product.
- NEVER allow children to stand, climb, or hang on any drawers, doors, or shelves.
- NEVER open more than one drawer at a time.
- Place heaviest items in the lowest drawers.

*This is a permanent label. Do not remove!*

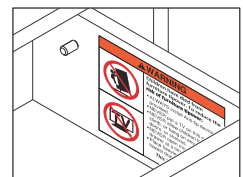

The assembled drawer with this warning must be placed on top of the unit.

# Step 27

To finish this up, let's secure your dresser to the wall!  
Attach the Wall anchor (P) to your dresser using Washer (O) and Screw (D).

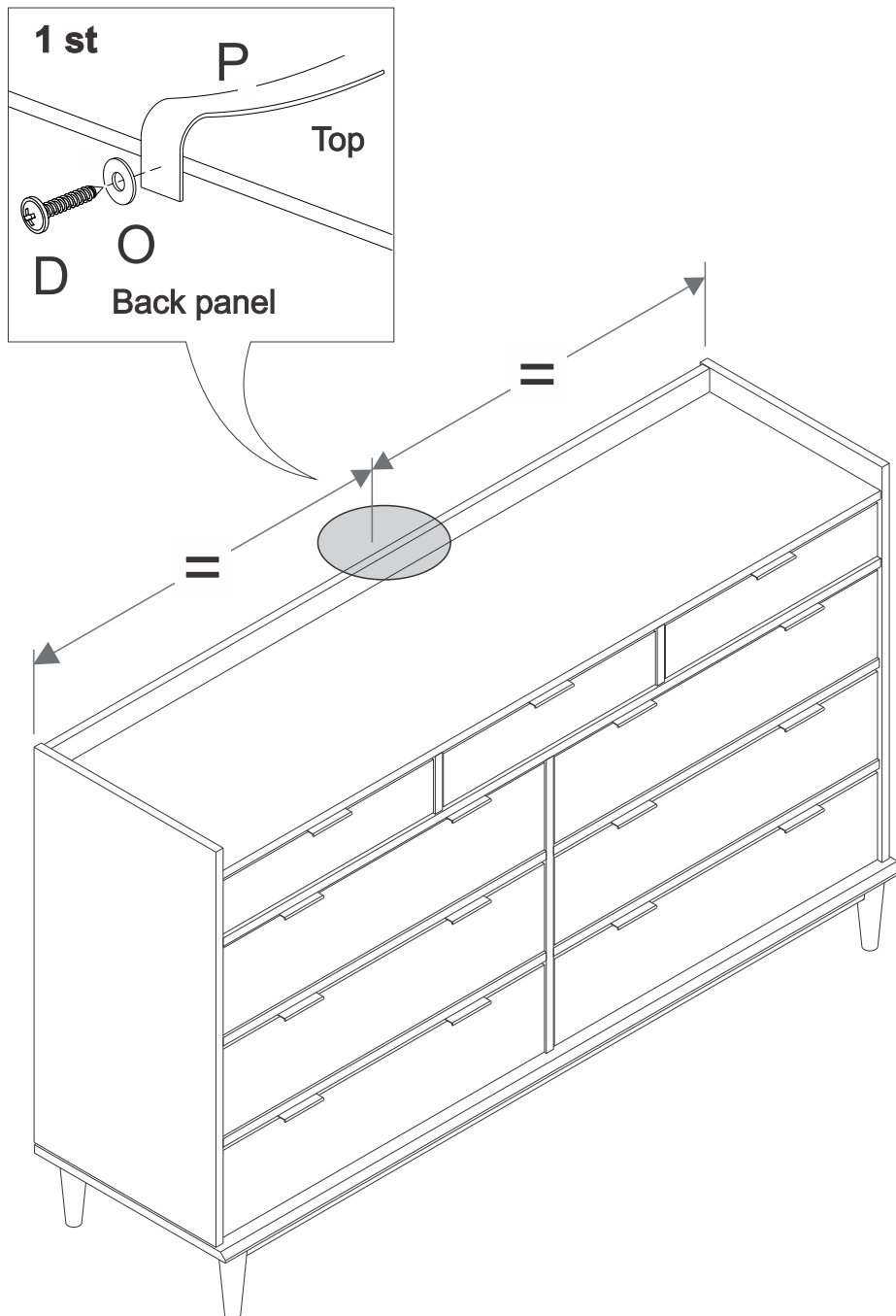

# Step 28

Insert the Plastic Bush (J) into the wall. Then, secure the Wall Anchor (P) to the wall using a Washer (O) and a Screw (I).

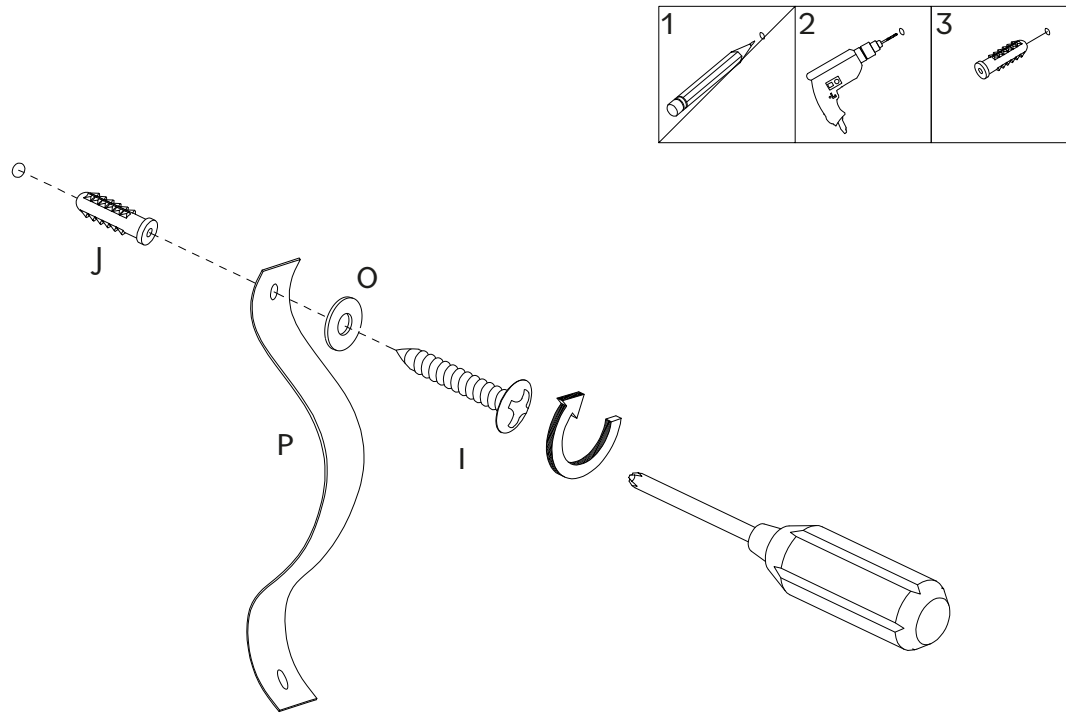

## WARNING

Serious or fatal injuries can occur from furniture tipping over. To prevent the furniture from tipping over we recommend that it is permanently fixed to the wall. Wall anchor and hardware are included with this product. Please make sure hardware is suitable for your walls before installing, as different wall materials may require different types of anchors.

Name and address information for the manufacturer responsible for the anti-tip hardware and date of production can be found on the label on the back of the furniture.



You did it! Enjoy your new Dresser!

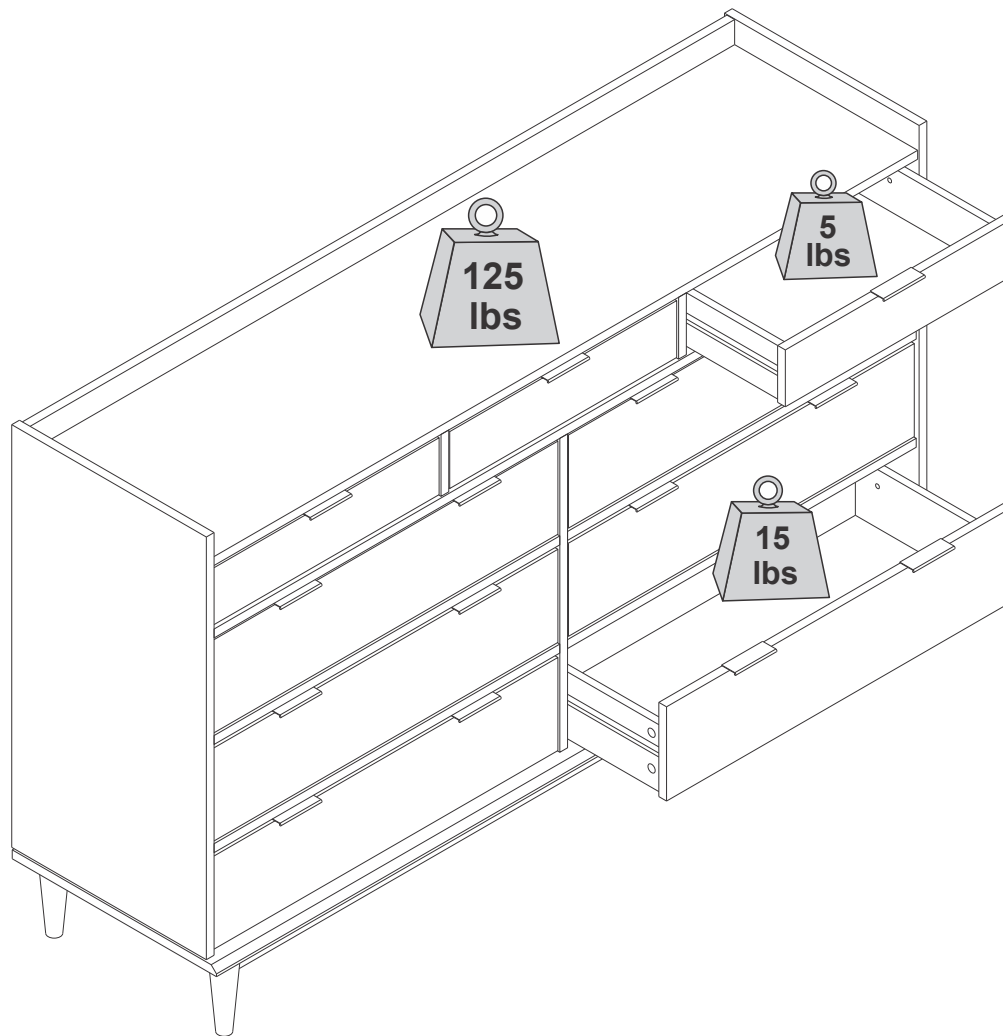

Congratulations on your new piece of furniture! We would love to hear about it and see it. Please leave us a review or post a picture with #mywalkerredisonhome

# Assembling furniture can be tricky sometimes.

Our customer service team, located in Utah, is here for product information, help assembling a product, or for any other customer support issue

Call us at **801-433-3008**

Email us at **[service@walkeredison.com](mailto:service@walkeredison.com)**

Visit our Customer Service website at **[walkeredison.com/pages/customer-service](http://walkeredison.com/pages/customer-service)**

We are available to help Monday-Thursday 8am-5pm, Friday 8am-3pm MST

For details on Assembly Videos, Assembly Instructions, Replacement Parts, and Customer service,

**SCAN HERE**

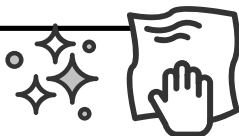

For cleaning, never use abrasives, use a soft cloth and water with neutral soap to clean the furniture.

# WALKER EDISON™

## Lee 9 Tiroir Commode en Bois Massif Lee C moda de Madera Maciza con 9 Cajones

SKU: BR9DRLEEDR-T



### *Pour usage r sidentiel seulement*

Visite notre site Web pour obtenir les instructions les plus r centes, des conseils d'assemblage, signaler des dommages ou commander des pi ces. [www.walkeredison.com](http://www.walkeredison.com)

### *S lo para uso residencial*

Visite nuestro sitio web para consultar las  ltimas instrucciones, consejos de montaje, notificar da os o solicitar piezas. [www.walkeredison.com](http://www.walkeredison.com)

# WE Il est temps de commencer / Hora de empezar

Prépare un lieu de travail propre et souple pour éviter tout dommage lors de l'assemblage. Tu peux utiliser la boîte et les protections internes comme base. Vérifie également que tu disposes de toutes les pièces et parties avant de te lancer dans l'assemblage.

Prepare un lugar de trabajo limpio y blando para evitar daños durante el montaje. Puede utilizar la caja y las protecciones internas como base. Comprueba también que tiene todas las piezas y partes antes de sumergirse en el montaje.

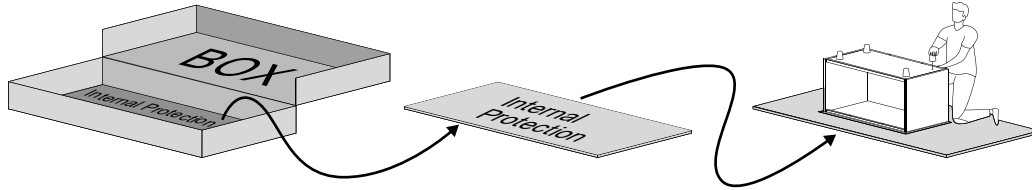

**Temps de montage  
estimé**  
**Tiempo estimado  
de montaje**

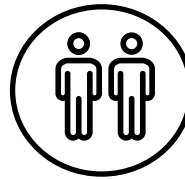

2 Person Build

**Personnes recommandées  
pour le montage.**

Fais-en un effort d'équipe ! Appelle un ami pour un assemblage plus rapide et plus facile.

**Personas recomendadas  
para el montaje.**

¡Hágalo en equipo! Llame a un amigo para que el montaje sea más rápido y sencillo.

## Outils nécessaires

Munis-toi d'un tournevis cruciforme et marteau pour réaliser cet assemblage

## Herramientas requeridas

Tome un destornillador Phillips y martillo para conquistar este conjunto.



## Utilise les outils électriques avec précaution

Ce meuble est réalisé en Bois Massif et Bois Composite, des matériaux souples. Si tu choisis d'utiliser des outils électriques, règle-les sur le mode le plus lent. Fais attention à toi !

Les outils électriques peuvent provoquer des fissures ou endommager les meubles, mais aussi les autres composants s'ils sont mal utilisés. Les dommages causés par un outil électrique ne sont pas couverts par la garantie Walker Edison.

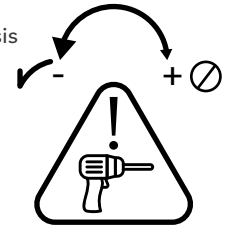

## Utilice las herramientas eléctricas con cuidado

Este mueble está fabricado con madera maciza y madera compuesta, materiales blandos. Si decide utilizar herramientas eléctricas, ajústelas al ajuste más lento. Tenga cuidado. Las herramientas eléctricas pueden causar grietas o daños en el mueble, pero también en los herrajes si se utilizan mal.

Los daños causados por una herramienta eléctrica no están cubiertos por la garantía de Walker Edison.

## Attention avec la glissière

Tes meubles possèdent des glissières en bois très résistantes. De temps en temps, nous recommandons d'appliquer de la paraffine ou de la cire de bougie standard pour améliorer la glisse des curseurs.

## Cuidado con las guías

Tus muebles cuentan con guías de madera de alta durabilidad. De vez en cuando, recomendamos la aplicación de parafina o cera estándar para mejorar el deslizamiento de los deslizadores.



**Scannez pour obtenir des conseils d'assemblage et de l'aide !**  
**Escanee para obtener consejos de montaje y ayuda!**

# WE Liste de pièces / Lista de piezas

Nombre de pièces Número de pieza	Description Descripción	Quantité Cantidad	Nombre de pièces Número de pieza	Description Descripción	Quantité Cantidad
01	Panneau Supérieur Panel Superior	01	17	Glissières en Bois Correderas	18
02	Panneau Gauche Panel Izquierdo	01	18	Petite Panneau Panel Pequeño	02
03	Panneau Droit Panel Derecho	01	19	Rail Supérieur Travesaño Superior	01
04	Panneau Inférieur Panel Inferior	01	20	Panneau Arrière Panel Trasero	01
05	Côté Droit du Tiroir Lado Izquierdo del Cajón	06	21	Panneau Arrière Inférieur Panel Trasero Inferior	01
06	Côté Droit du Tiroir Lado Derecho del Cajón	05	22	Pied Central Pie Central	01
07	Côté Droit du Tiroir (Avertissement) Lado Derecho del Cajón (Advertencia)	01	23	Petite Façade du Tiroir Frente del Cajón Pequeño	03
08	Façade du Tiroir Frente del Cajón	06	34	Rail Avant Inférieur Travesaño Frontal Inferior	02
09	Fond du Tiroir Fondo del Cajón	06	35	Travessa Lateral Inferior Travessa Lateral Inferior	02
10	Arrière du Tiroir Trasera del Cajón	06	36	Pied Pie	04
14	Rail Avant Travesaño Frontal	04	45	Petit Arrière du Tiroir Trasero del Cajón Pequeño	03
15	Grand Rail Avant Travesaño Frontal Grande	02	46	Petit Côté Gauche du Tiroir Lado Izquierdo del Cajón Pequeño	03
16	Panneau Central Panel Central	01	47	Petit Côté Droit du Tiroir Lado Derecho del Cajón Pequeño	03
			48	Petit Fond du Tiroir Parte Inferior del Cajón Pequeño	03

**WALKER EDISON**  
 Distribution and responsible for the anti-tip hardware.  
 Walker Edison Furniture Company  
 1553 W 9000 S, West Jordan, UT 84088 United States

**LEE**  
 Model: XXXXXXXXFF  
 LOT: AYYYWW-XXX  
 Date: MM/20YY  
 Rev: MM/20YY-VX

CAMBER compliant conforme al CAMBER.  
 TSCA Title VI compliant conforme al Título VI de la TSCA.  
 TSCA Title VI certified según el certificado del Título VI de la TSCA.  
 California 66100 Compliant for Prop 65.  
 Conforme a la norma California 66100 para la Prop 65.

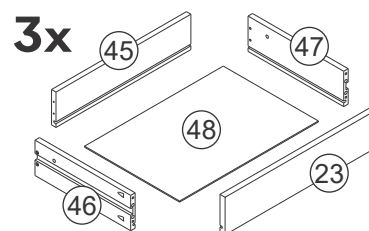
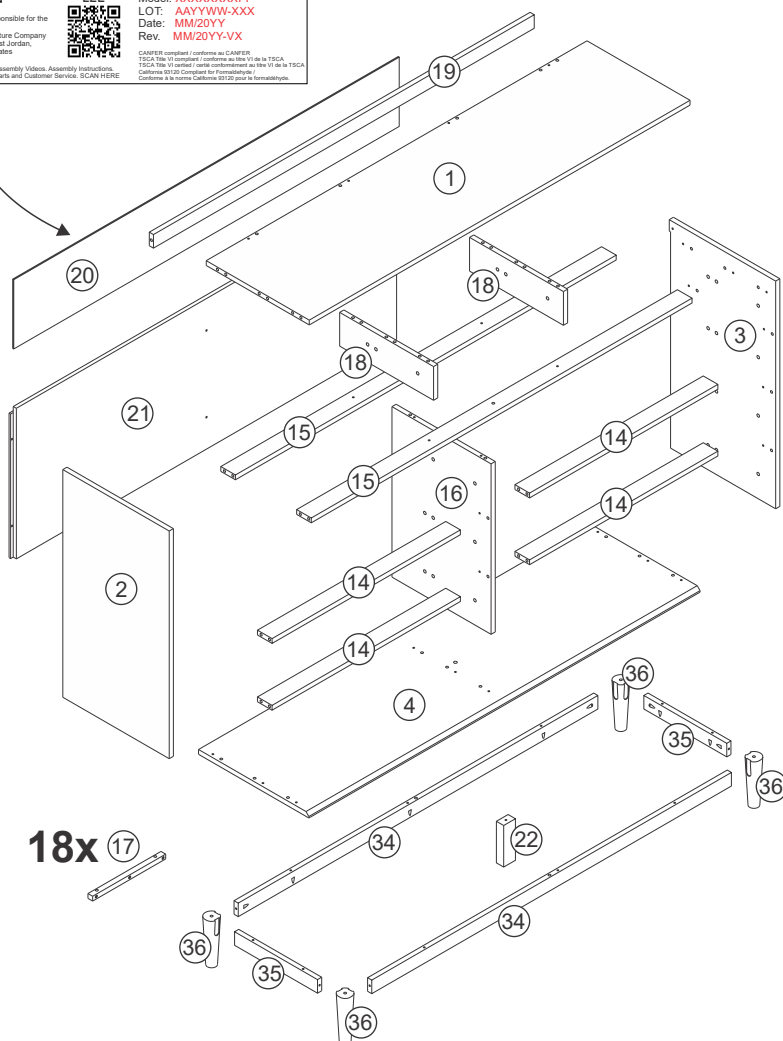

**WARNING**

Children have died from furniture tipover. To reduce the risk of furniture tipover:

- ALWAYS install Anti-tip device provided.
- NEVER put a TV on this product.
- NEVER allow children to stand, climb, or hang on any drawers, doors, or shelves.
- NEVER open more than one drawer at a time.
- Place heaviest items in the lowest drawers.







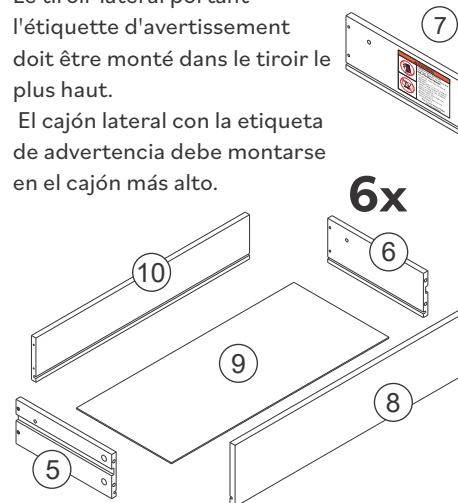



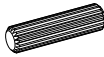

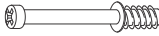

*This is a permanent label. Do not remove!*

Le tiroir latéral portant l'étiquette d'avertissement doit être monté dans le tiroir le plus haut.

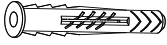
El cajón lateral con la etiqueta de advertencia debe montarse en el cajón más alto.

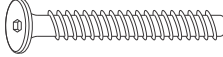
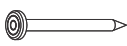
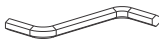

## WE Liste de composants / Lista de hardware

Partie Parte	Taille Tamaño	Nom Nombre	Quantité Cantidad
A 	8x30mm	Cheville en bois Espiga de madeira	84
B 	8x40mm	Cheville en bois Espiga de madeira	18
C 	3,0x12mm	Vis Tornillo	30
D 	3,5x20mm	Vis Tornillo	05
E 	4,0x40mm	Vis Tornillo	33
F 	5x24mm	Goujon de Assemblage Conector	50
G 	10x20mm	Cheville en bois Espiga de madeira	54
H 	4,0x25mm	Vis Tornillo	54
I 	4,0x30mm	Vis Tornillo	55
J 	6x35mm	Douille en plastique Buje de plástico	01
K 	15x12mm	Vis Mini Fix Tornillo Mini Fix	50
L 	7,0x50mm	Vis Tornillo	01
M 	8x8mm	Clou Clavo	20
N 		Clé hexagonale Llave Allen	01
O 		Rondelle Arandela	02
P 		Ruban Cinta	01
Q 		Poignée Manija	15

Les quantités de composants indiquées ci-dessus sont nécessaires pour un assemblage correct.  
Des pièces supplémentaires peuvent être incluses.

Las cantidades de tornillería indicadas anteriormente son necesarias para un montaje correcto.  
Se pueden incluir piezas de ferretería adicionales.

# Étape / Paso 1

(FR)

Commençons! Insère les Chevilles (G) dans le Glissières en Bois (17).

(ES)

¡Manos a la obra! Inserta las Espigas (G) em las Correderas (17).

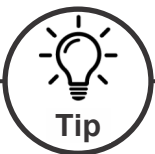
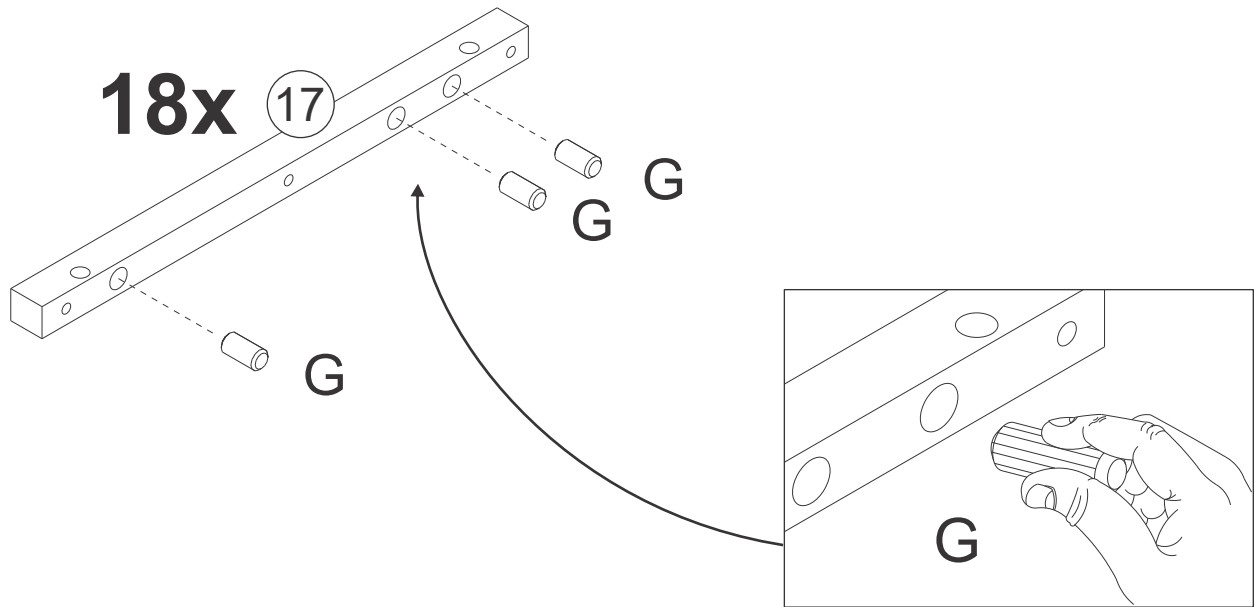
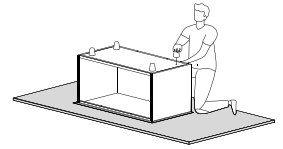

## Tip

Les chevilles sont essentielles lors de l'assemblage de meubles pour créer des connexions solides et précises. Elles garantissent l'intégrité structurelle, empêchent les déplacements et simplifient l'alignement, ce qui permet d'obtenir des meubles plus résistants et plus durables. Suis ces étapes:

Las espigas son esenciales en el montaje de muebles para crear uniones fuertes y precisas. Garantizan la integridad estructural, evitan el desplazamiento y simplifican la alineación, lo que se traduce en muebles más resistentes y duraderos. Sigue estos pasos:

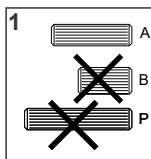

- 1: Sélectionne la taille de cheville appropriée en fonction de l'étape.
- 1: Seleccione el tamaño de espiga adecuado según el paso.

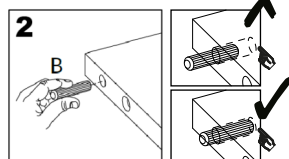

- 2: Insère dans le trou indiqué et appuie fermement pour assurer un positionnement correct.
- 2: Insértela en el orificio indicado y presione firmemente para asegurar su correcta colocación.

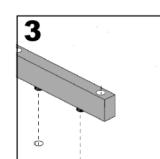

- 3: Aline la cheville avec la pièce correspondante et enfonce-la jusqu'à ce qu'elle soit ferme.
- 3: Alinee el pasador con la pieza correspondiente y presiónelo hasta que encaje

# Étape / Paso 2

(FR)

Insérez la Cheville (A) dans le Panneau Supérieur (01), Panneau Gauche (02), Panneau Droit (03), Rail Avant (14), Grand Rail Avant (15), Panneau Central (16), Petite Panneau (18), Rail Supérieur (19), Rail Avant Inférieur (34), Rail Inférieur (35), Pied (36), Petit Côté Gauche du Tiroir (46) et Petit Côté Droit du Tiroir (47).

(ES)

Inserte la Espiga (A) en el Panel Superior (01), Panel Izquierdo (02), Panel Derecho (03), Travesaño Frontal (14), Travesaño Frontal Grande (15), Panel Central (16) Panel Pequeño (18), Travesaño Superior (19), Travesaño Frontal Inferior (34), Travesaño Inferior (35), Pie (36), Lado Izquierdo del Cajón Pequeño (46) y Lado Derecho del Cajón Pequeño (47).

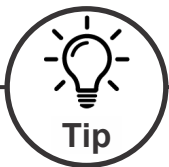
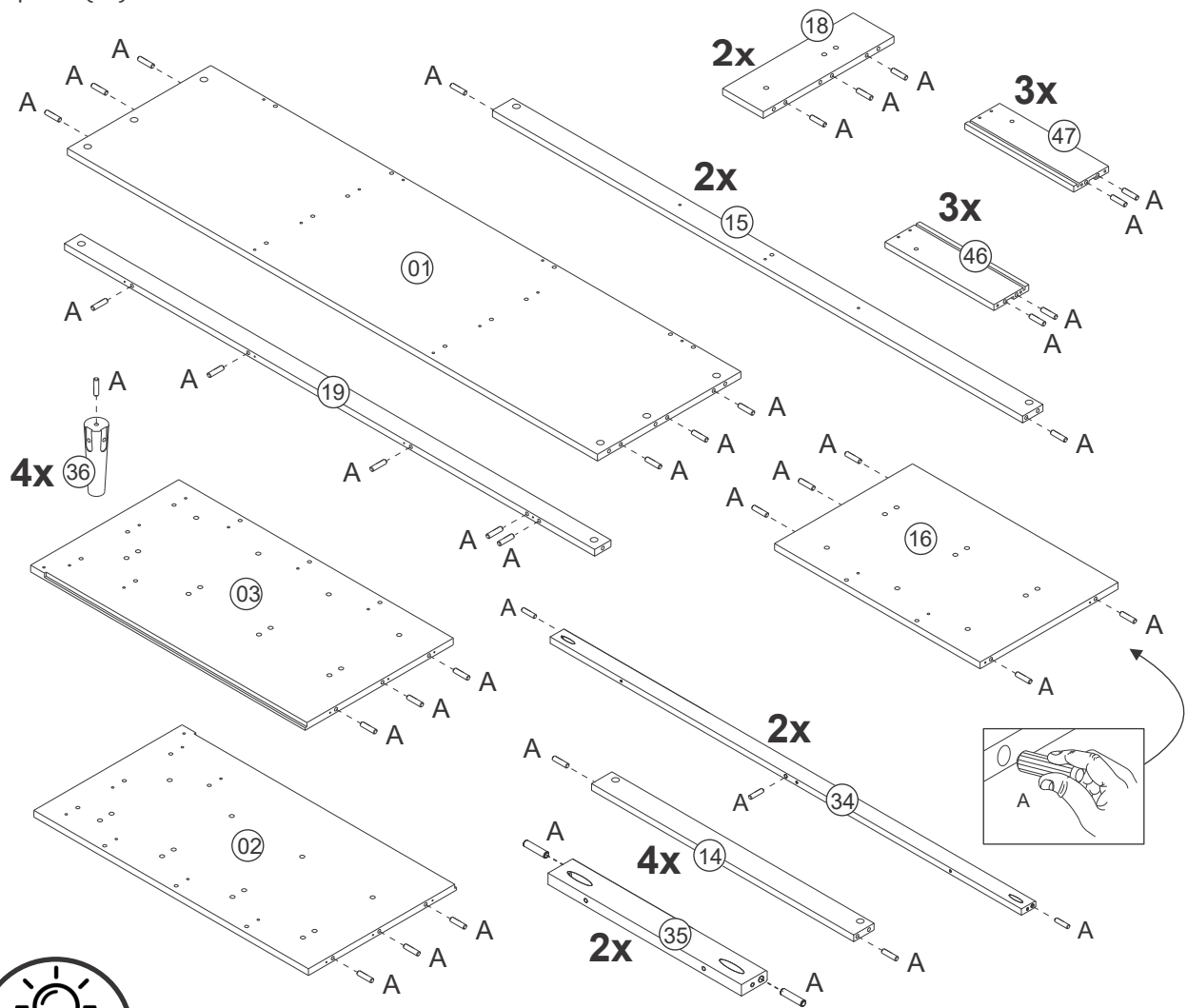

Pour que ton produit conserve son meilleur aspect et sans rayures, essaie de le monter sur une surface souple telle qu'un tapis ou une couverture. Cela permet d'éviter les rayures accidentelles et de garder tes meubles en bon état!

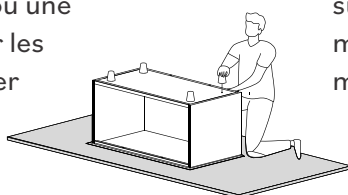

Para mantener su producto con el mejor aspecto y sin arañazos, pruebe a montarlo sobre una superficie blanda, como una alfombra o una manta. Así evitará arañazos accidentales y mantendrá sus muebles en perfecto estado.



# Étape / Paso 3

(FR)

Fixez la Glissière (17) au Panneau Gauche (02), Panneau Droit (03), Panneau Central (16) et Panneau Petite (18) avec la Vis (H) et un tournevis Phillips.

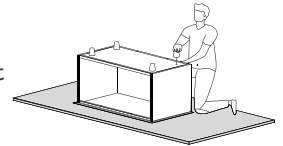

(ES)

Asegure la Corredera (17) al Panel Izquierdo (02), Panel Derecho (03), Panel Central (16) y a Panel Pequeño (18) con el Tornillo (H) y un destornillador Phillips.

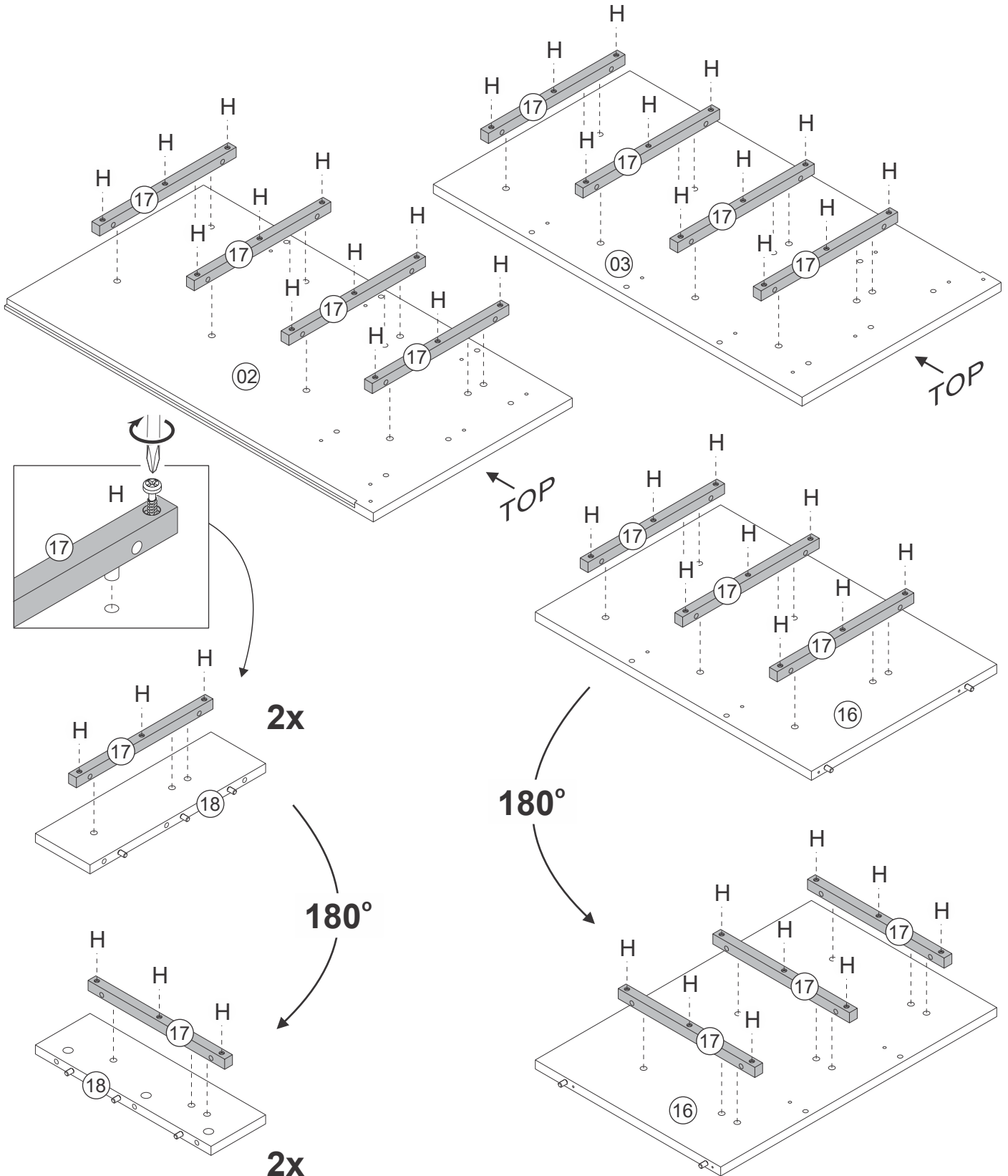

# Étape / Paso 4

(FR)

Fixez les Goujons de Assemblage (F) dans le Panneau Supérieur (01), Panneau Gauche (02), Panneau Droit (03), Façade du Tiroir (08) et Panneau Central (16) à l'aide d'un tournevis Phillips.

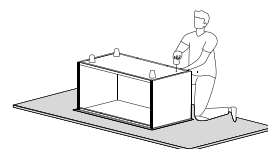

(ES)

Coloque los Conectores (F) en el Panel Superior (01), Panel Izquierdo (02), Panel Derecho (03), Frente del Cajón (08) y Panel Central (16) con un destornillador Phillips.

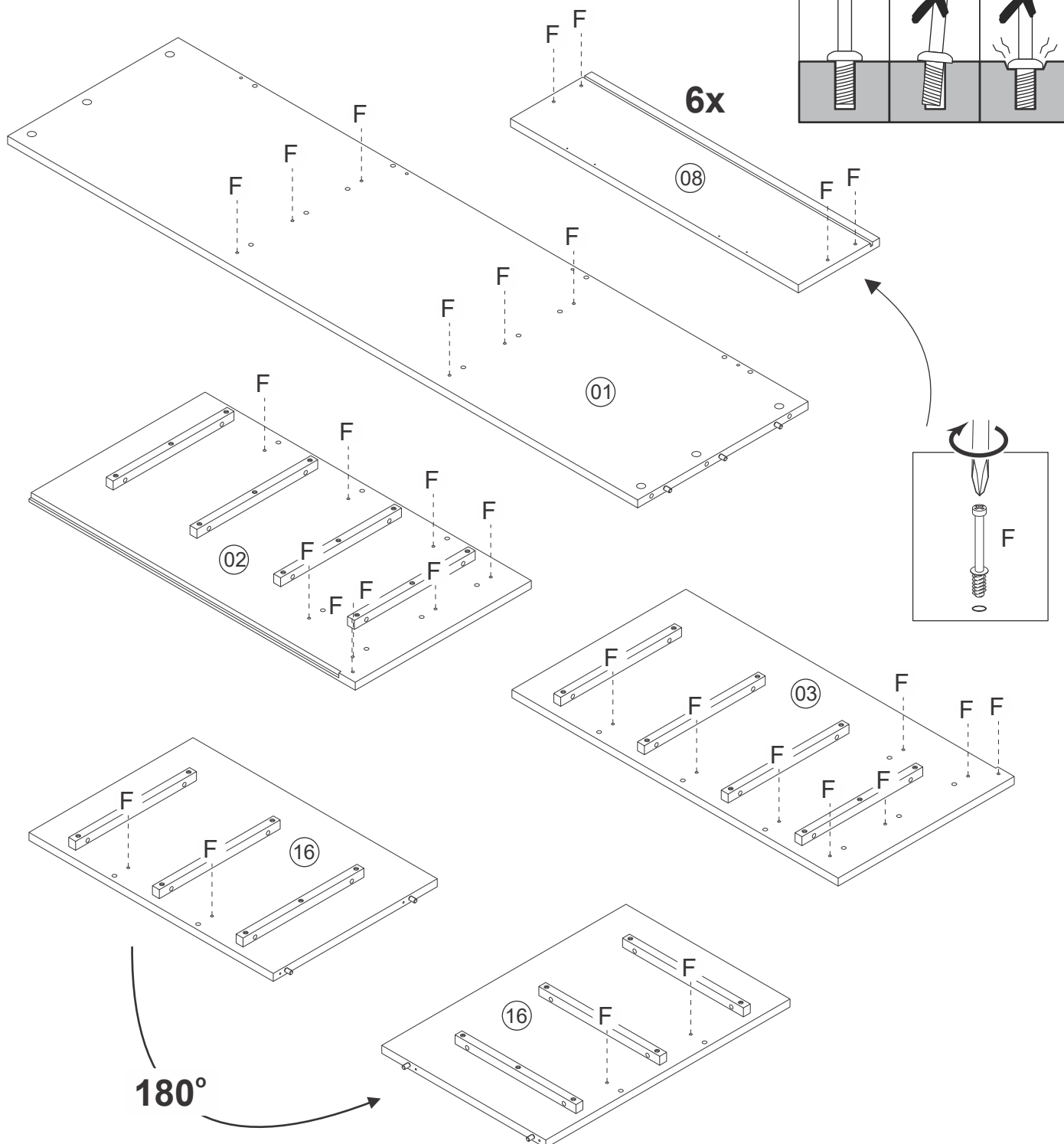

# Étape / Paso 5

(FR)

Fixez le Rail Supérieur (19) au Panneau Supérieur (01) à l'aide de la Vis (I) et d'un tournevis Phillips.

(ES)

Asegure el Travesaño Superior (19) Panel Superior (01) usando el Tornillo (I) y un destornillador Phillips.

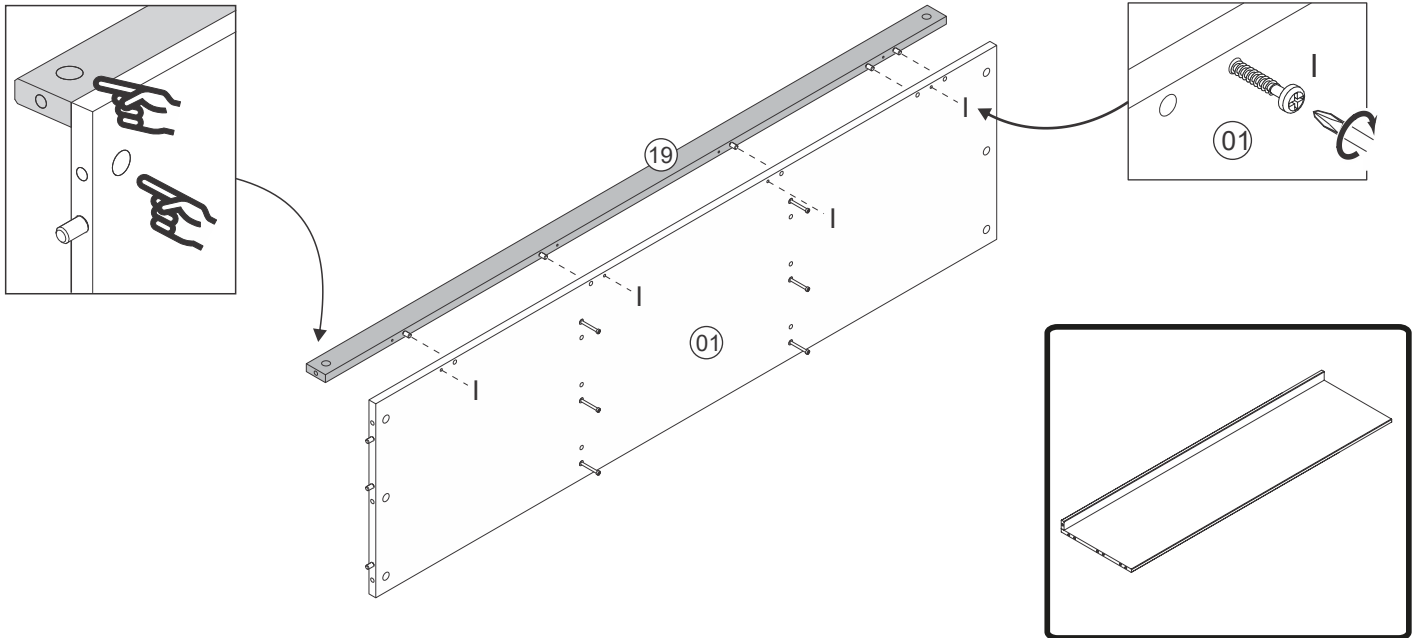
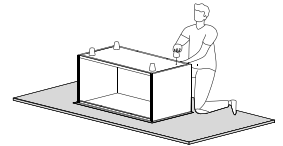

# Étape / Paso 6

(FR)

Fixez le Panneau Petite (18) au Panneau Supérieur (01). Insérez les Boitiers du Assemblage (K) dans la Panneau Petite (18) et serrez avec un tournevis Phillips.

(ES)

Asegure la División Pequeña (18) al Panel Superior (01). Inserte las Trabas del Conector (K) en la División Pequeña (18) y apriételes con un destornillador Phillips.

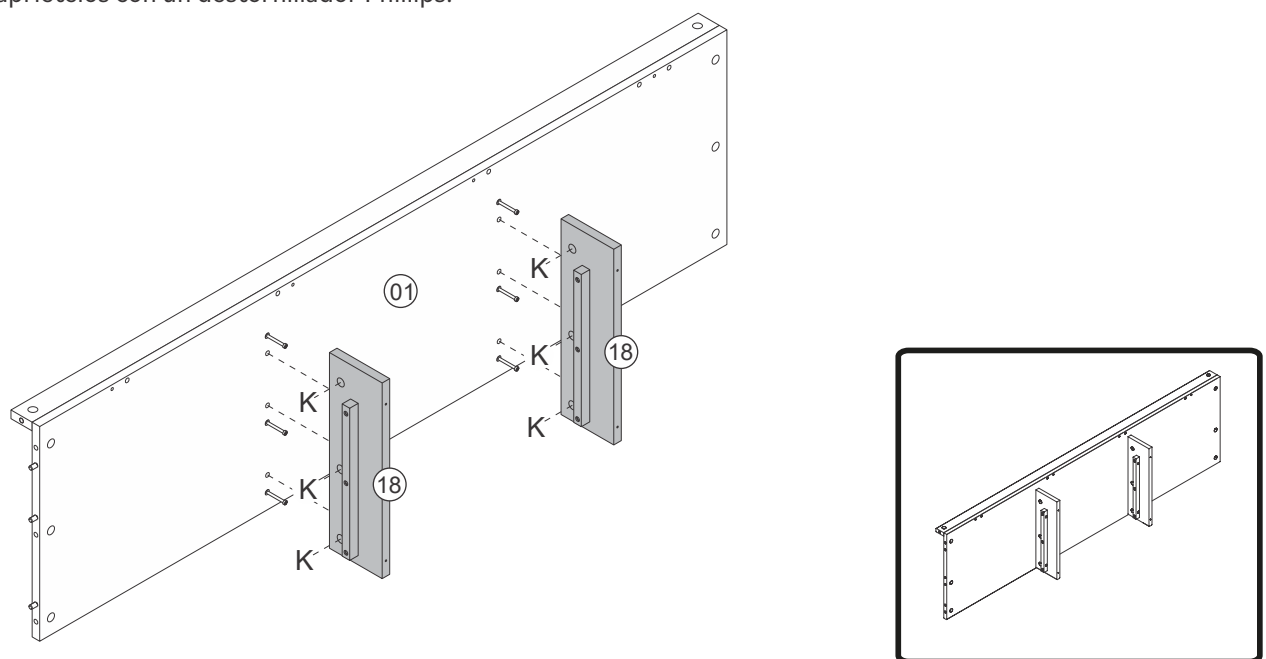

# Étape / Paso 7

(FR)

Fixez le Grand Rail Avant (15) à la Panneau Central (16) à l'aide de la Vis (E) et d'un tournevis Phillips.

(ES)

Asegure el Travesaño Frontal Grande (15) al Panel Central (16) usando el Tornillo (E) y un destornillador Phillips. Preste atención a los detalles para ensamblar usando el lado correcto.

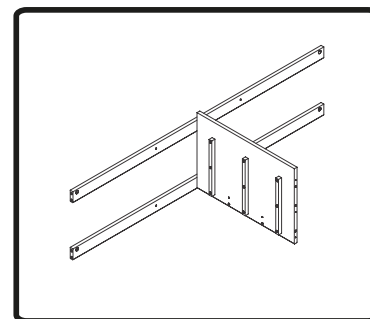
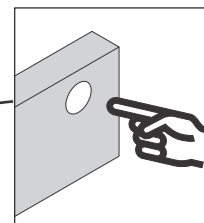
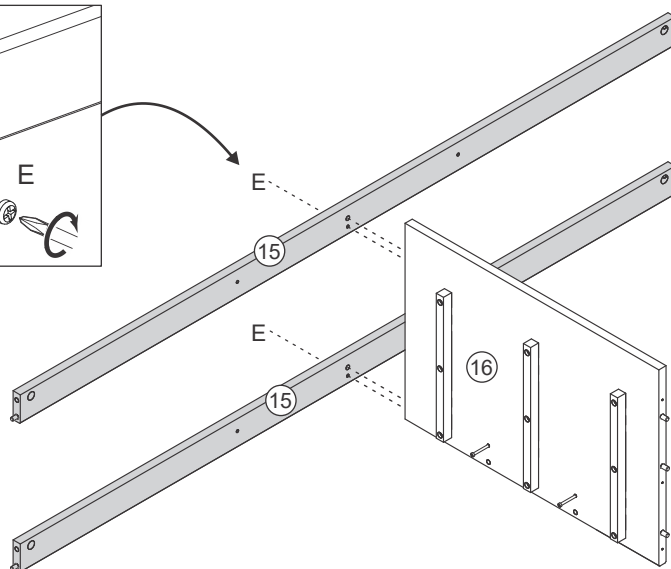
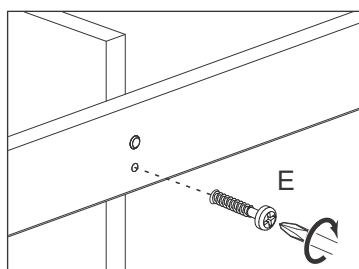
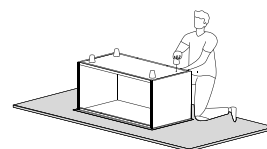

# Étape / Paso 8

(FR)

Fixez le Grand Rail Avant (15) à le Panneau Petite (18) avec la Vis (E) et un tournevis Phillips.

(ES)

Asegure el Travesaño Frontal Grande (15) al Panel Pequeño (18) con un Tornillo (E) y un destornillador Phillips.

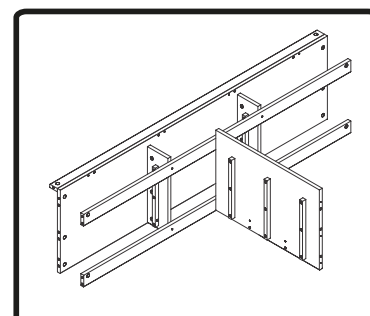
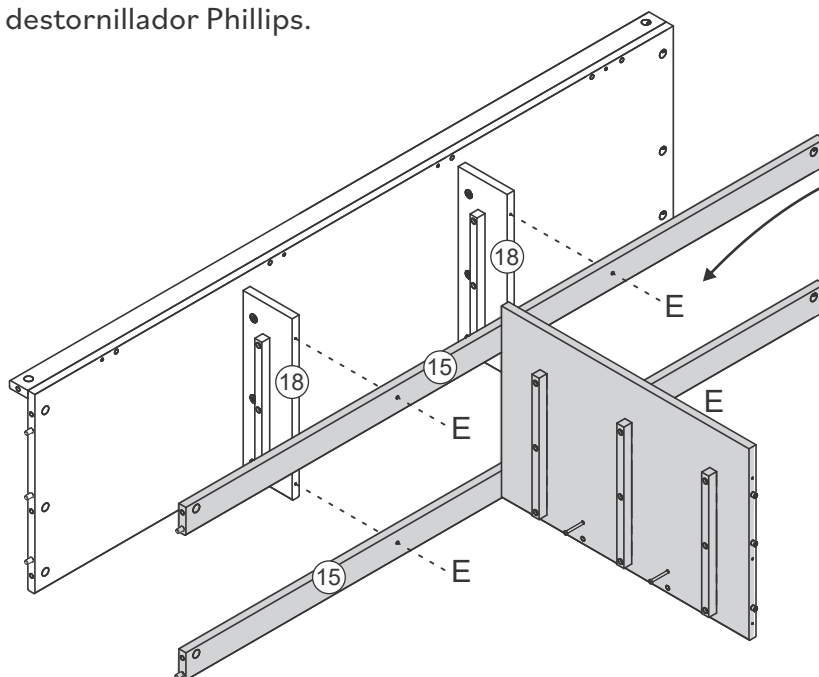
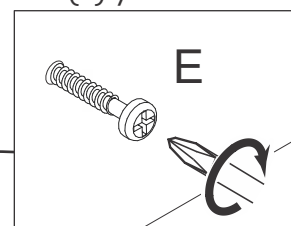

# Étape / Paso 9

(FR)

Fixez le Rail Avant (14) à la Panneau Central (16). Insérez les Boitier de Assemblage (K) dans le Rail Avant (14) et serrez avec un tournevis Phillips.

(ES)

Asegure el Travesaño Delantero (14) al Panel Central (16). Inserte las Trabas del Conector (K) en el Travesaño Frontal (14) y apriételes con un destornillador Phillips.

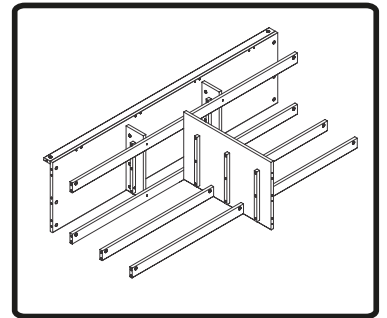
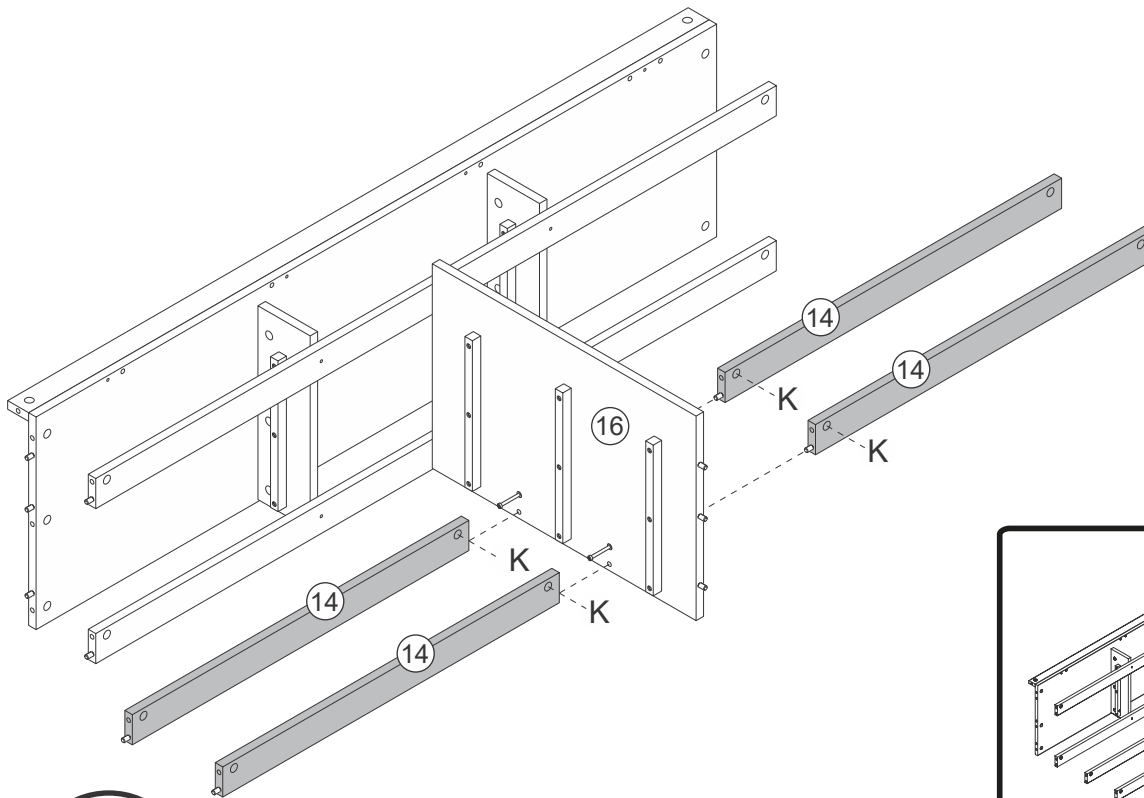
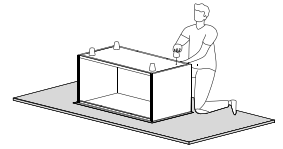

Dica

## Mini Fix

Mini Fix permet de joindre deux pièces en toute sécurité. Suis ces étapes simples.

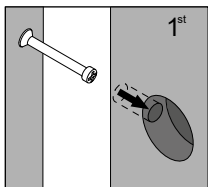

1<sup>st</sup>

1: Insère le Mini Fix dans les orifices du côté plat. Ne serre pas trop !

1: Coloca el tornillo Mini Fix en los orificios del lado plano. ¡No aprietes demasiado!

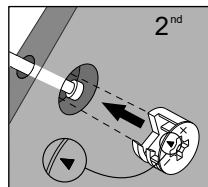

2<sup>nd</sup>

2: Joins les pièces en bois. Les vis Mini Fix entrent dans les orifices qui ont des trous sur les côtés, tu dois pouvoir voir les vis Mini Fix à travers ceux-ci. Après avoir installé les pièces, insère le tambour Mini Fix dans les orifices latéraux

2: Una las piezas de madera. Los tornillos Mini Fix entran en las piezas que tienen orificios en los lados, por lo que deberías poder ver los tornillos Mini Fix a través de ellos. Después de encajar las piezas, inserta el tambor del tornillo Mini Fix en los orificios laterales.

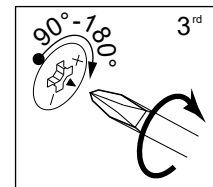

3<sup>rd</sup>

3: Sur la partie arrière du tambour, il aura la forme d'un « C ». Insère le tambour de manière à ce que l'ouverture « C » s'emboîte à la vis Mini Fix. Serre-la avec le tournevis.

3: La parte posterior del tambor tendrá la forma de "C". Inserta el tambor de modo que la abertura de la "C" encaje en el tornillo Mini Fix. Apriétalo con un destornillador.

# Étape / Paso 10

(FR)

Fixez le Panneau Supérieur (01), Rail Avant (14), Grand Rail Avant (15) et Rail Supérieur (19) au Panneau Gauche (02). Insérez ensuite les Boitier de Assemblage (K) dans le Panneau Supérieur (01), Rail Avant (14), Grand Rail Avant (15), Rail Supérieur (19) et serrez avec un tournevis Phillips.

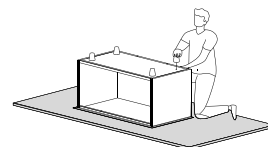

(ES)

Asegure el Panel Superior (01), Travesaño Frontal (14), Travesaño Frontal Grande (15) y el Travesaño Superior (19) al Panel Izquierdo (02). Luego inserte las Trabas del Conector (K) en el Panel Superior (01), Travesaño Frontal (14), Travesaño Frontal Grande (15), Travesaño Superior (19) y apriete con un destornillador Phillips

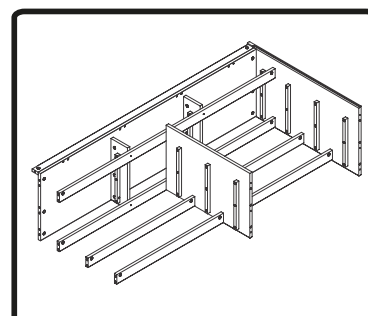
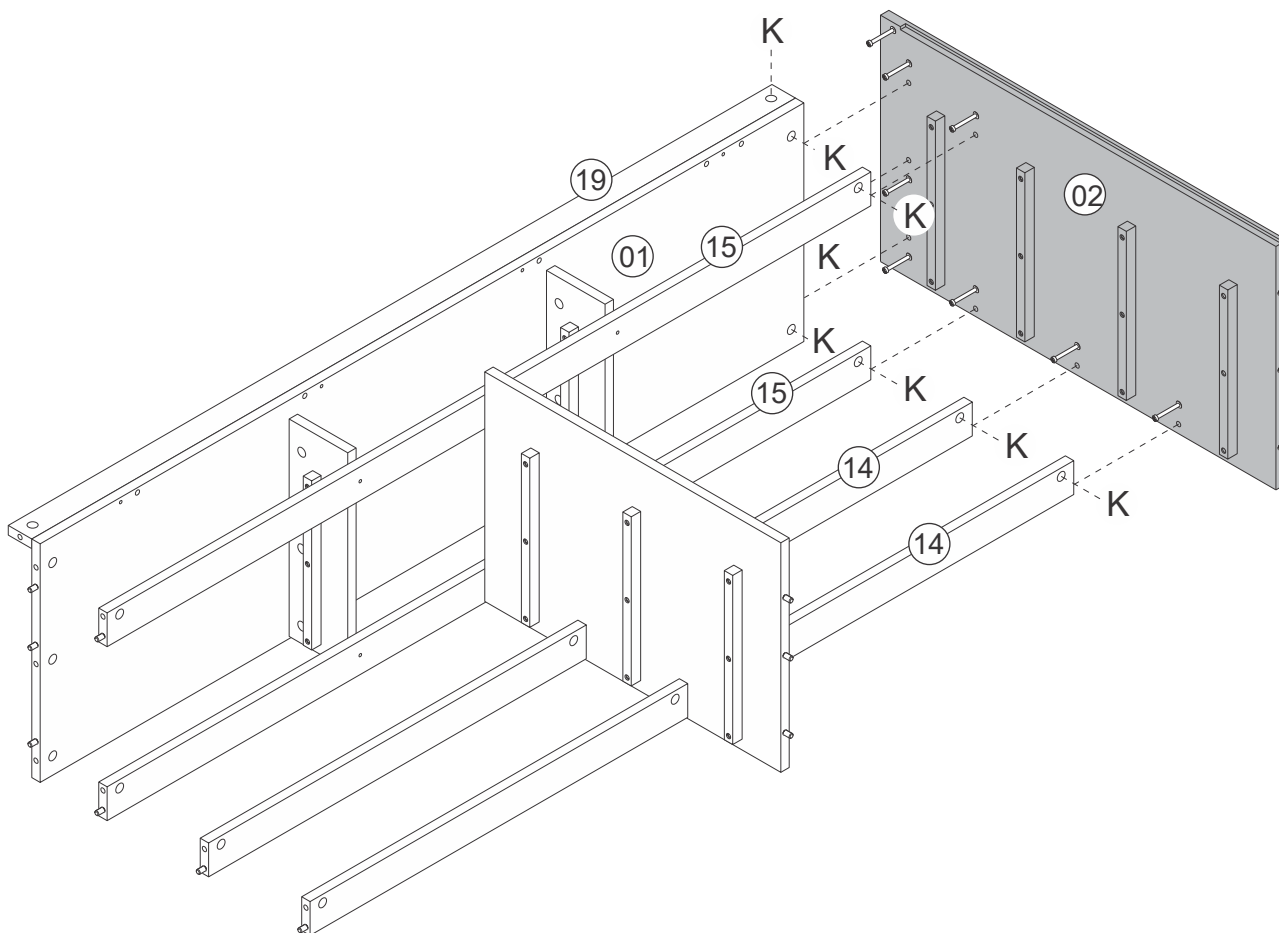

# Étape / Paso 11

(FR)  
Faites de même pour assembler le Panneau Droit (03)

(ES)  
Haga lo mismo para ensamblar el Panel Derecho (03)

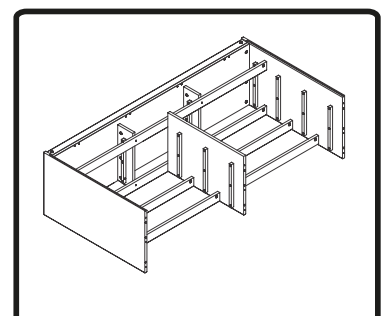
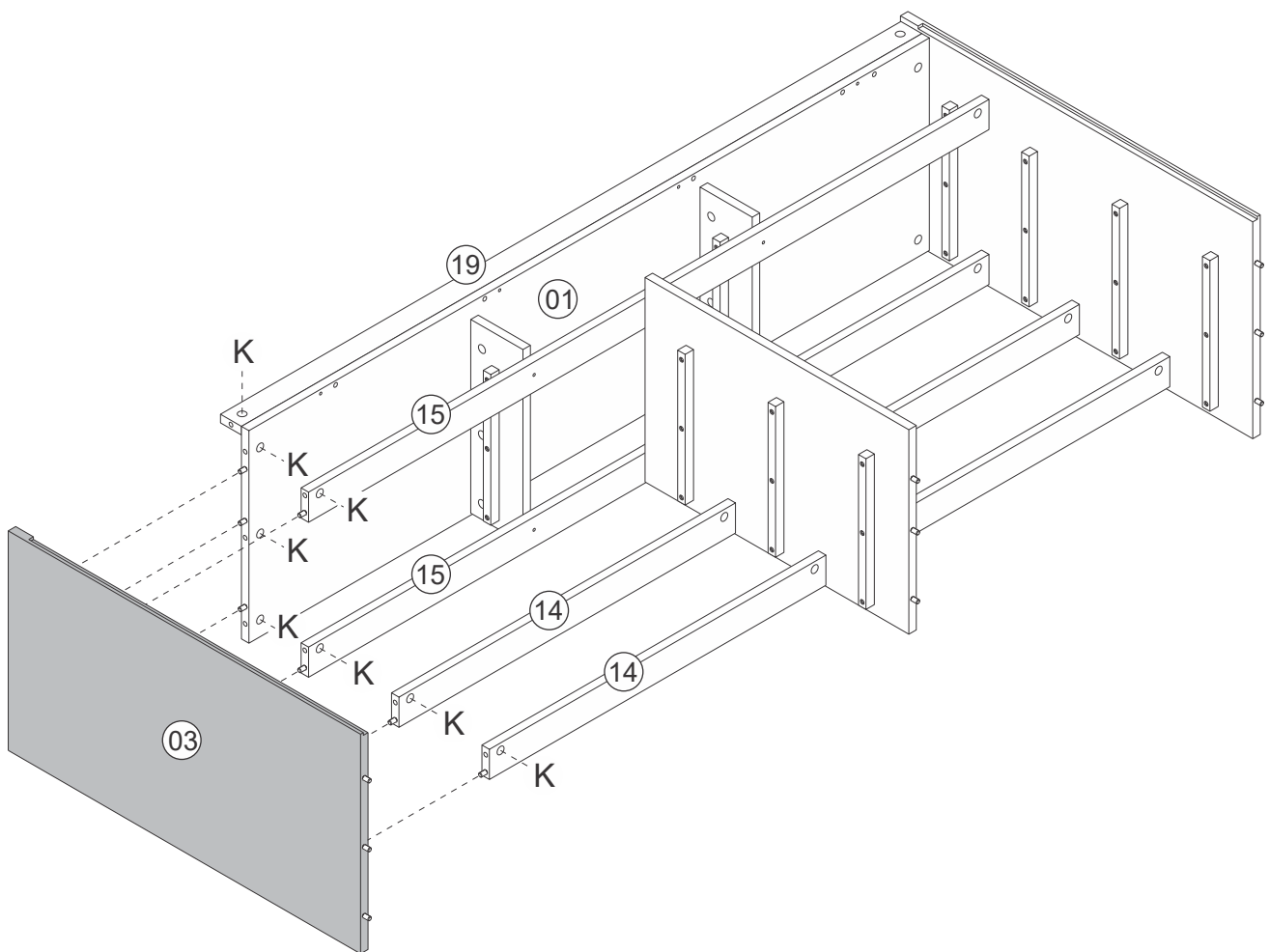
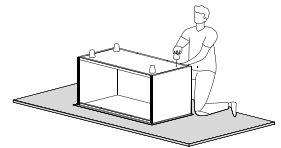

# Étape / Paso 12

(FR)

Pour assembler le bas, commencez par fixer le Pied Central (22) à le Panneau Inférieur (04) avec le Boulon (L) et la Clé hexagonale (N).

(ES)

Para ensamblar la parte inferior, comience fijando el Pie Central (22) al Panel Inferior (04) con el Perno (L) y la llave Allen (N)

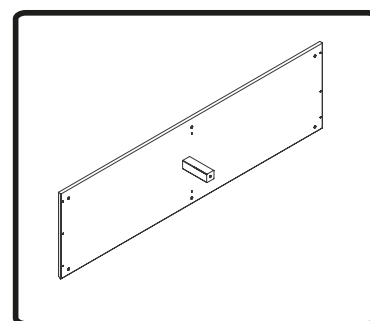
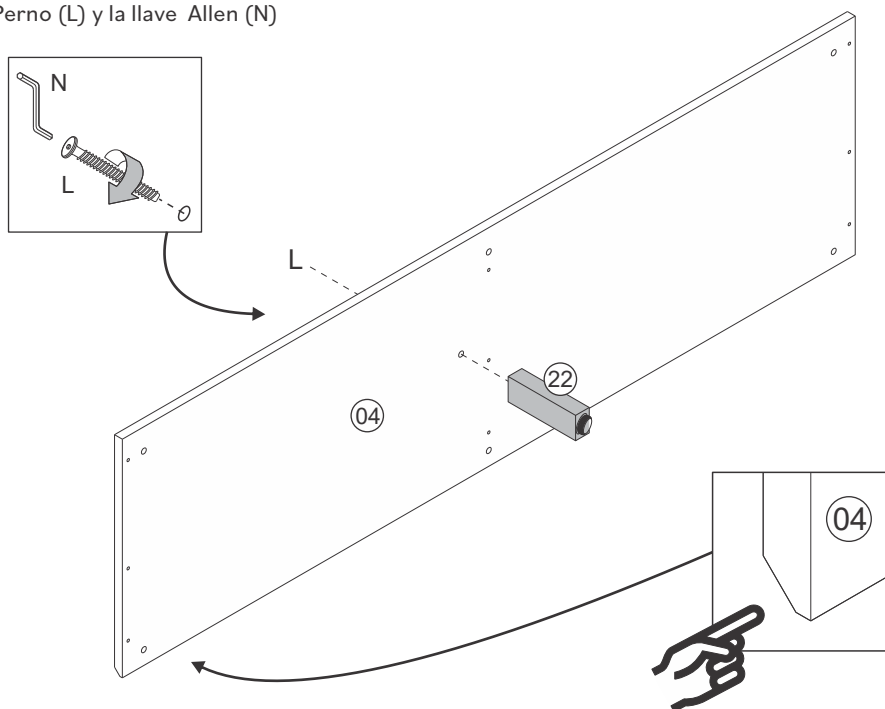
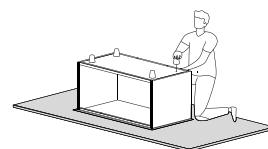

# Étape / Paso 13

(FR)

Fixez le Panneau Inférieur (04) au Panneau Gauche (02), Panneau Droit (03) et à le Panneau Central (16) à l'aide de la Vis (E) et d'un tournevis Phillips. Faites attention au côté auquel l'angle de l'avant de la base (04) doit faire face.

(ES)

Asegure el Panel Superior (04) al Panel Izquierdo (02), Panel Derecho (03) y el Panel Central (16) usando Tornillo (E) y un destornillador Phillips. Preste atención al lado hacia el que debe mirar el ángulo en el frente del Panel Inferior (04)

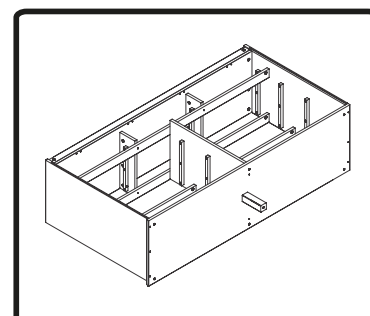
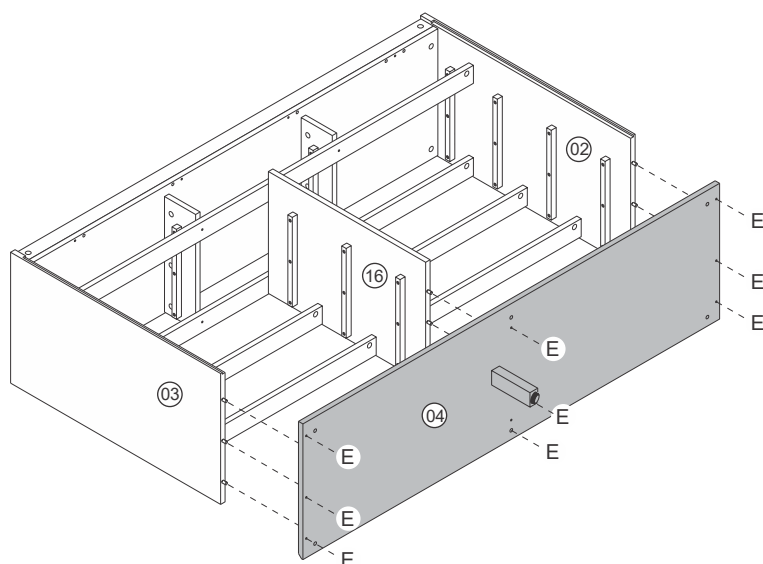



# Étape / Paso 14

(FR)

Fixez le Rail Avant Inférieur (34) au Pied (36) avec la Vis (E) et un tournevis Phillips.

(ES)

Asegure el Riel Frontal Inferior (34) al Pie (36) con un Tornillo (E) y un destornillador Phillips.

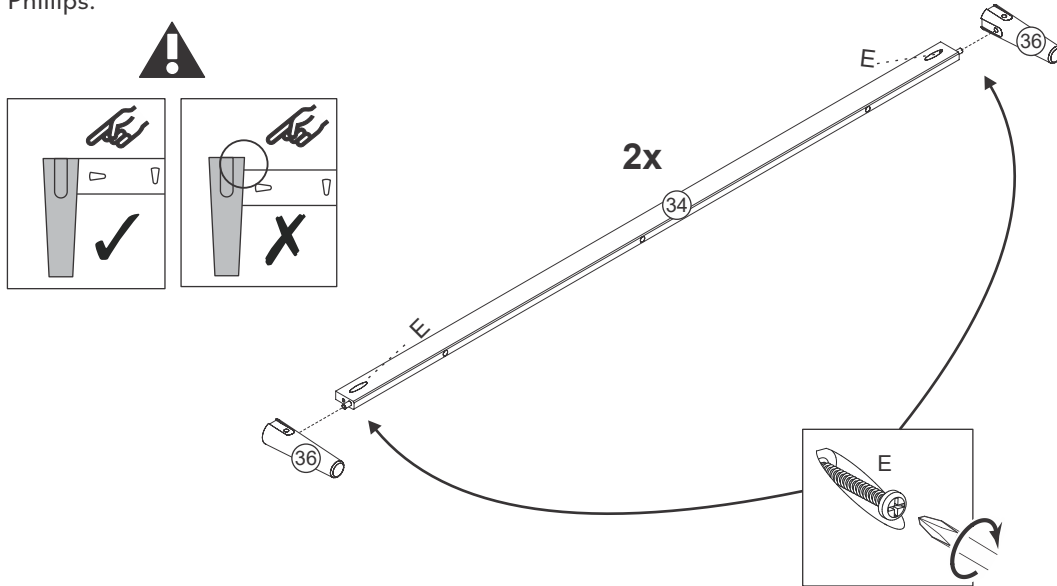
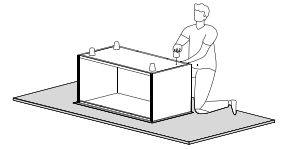

# Étape / Paso 15

(FR)

Fixez le Pied (36) au Rail Latéral Inférieur (35) à l'aide de la Vis (E) et d'un tournevis phillips.

(ES)

Asegure el Pie (36) al Travesaño Lateral Inferior (35), con un Tornillo (E) y un destornillador Phillips.

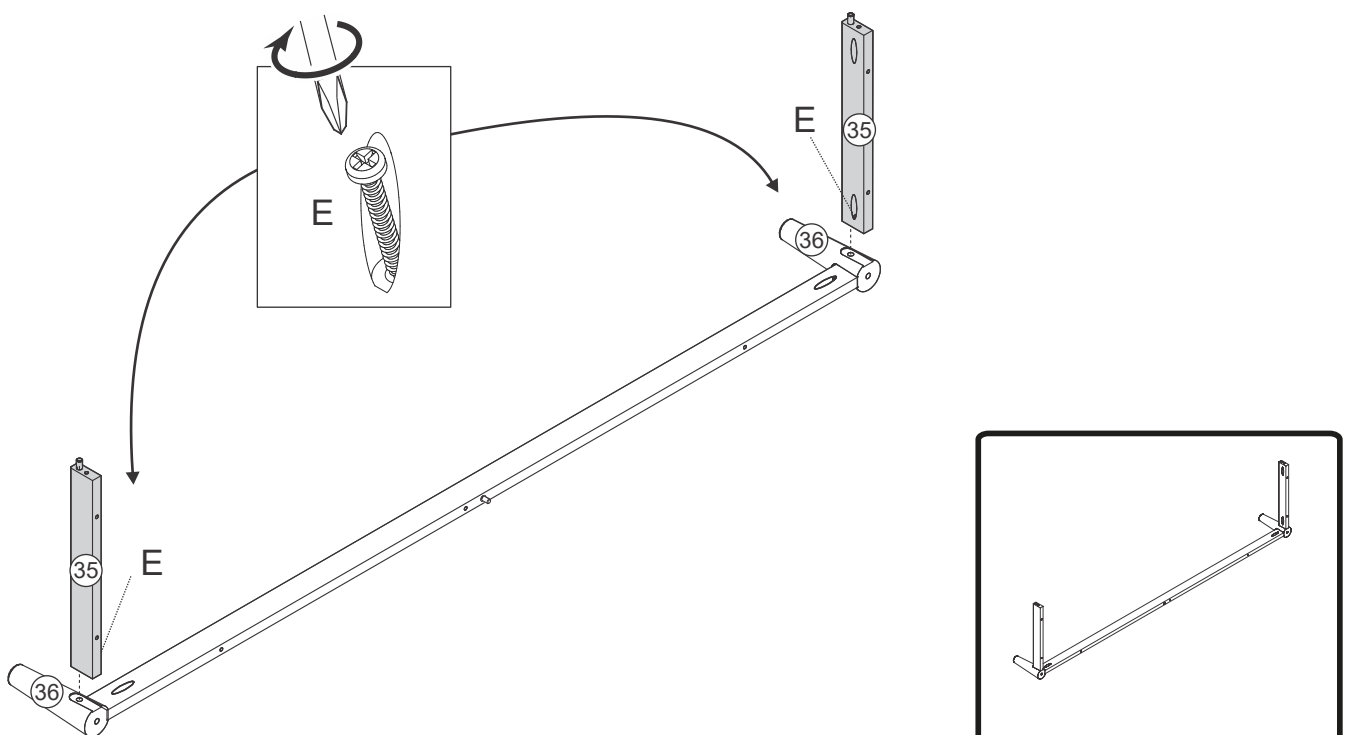

# Étape / Paso 16

(FR)

Fixez l'autre Pied (36) au Panneau Latéral Inférieur (35) à l'aide de la Vis (E) et d'un tournevis Philips.

(ES)

Asegure el otro Pie (36) al Panel Lateral Inferior (35) con un Tornillo (E) y un destornillador Phillips.

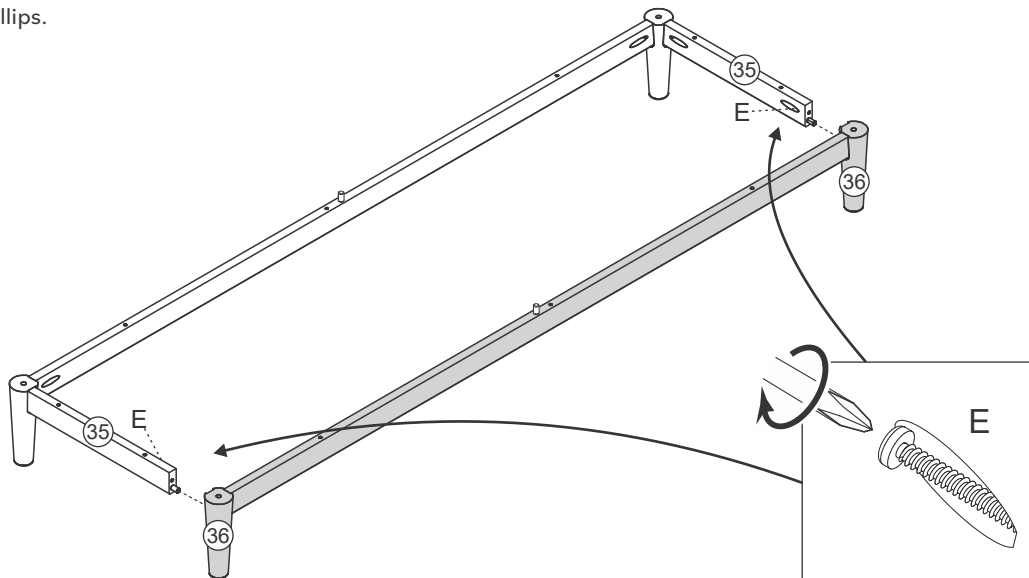
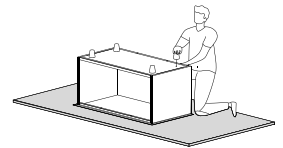

# Étape / Paso 17

(FR)

Fixez le Rail Avant Inférieur (34) et le Rail Latéral Inférieur (35) à le Panneau Inférieur (04) à l'aide de la Vis (E) et d'un tournevis Phillips

(ES)

Asegure el Travesaño Frontal Inferior (34) y el Travesaño Lateral Inferior (35) al Panel Inferior (04) usando el Tornillo (E) y un destornillador Phillips.

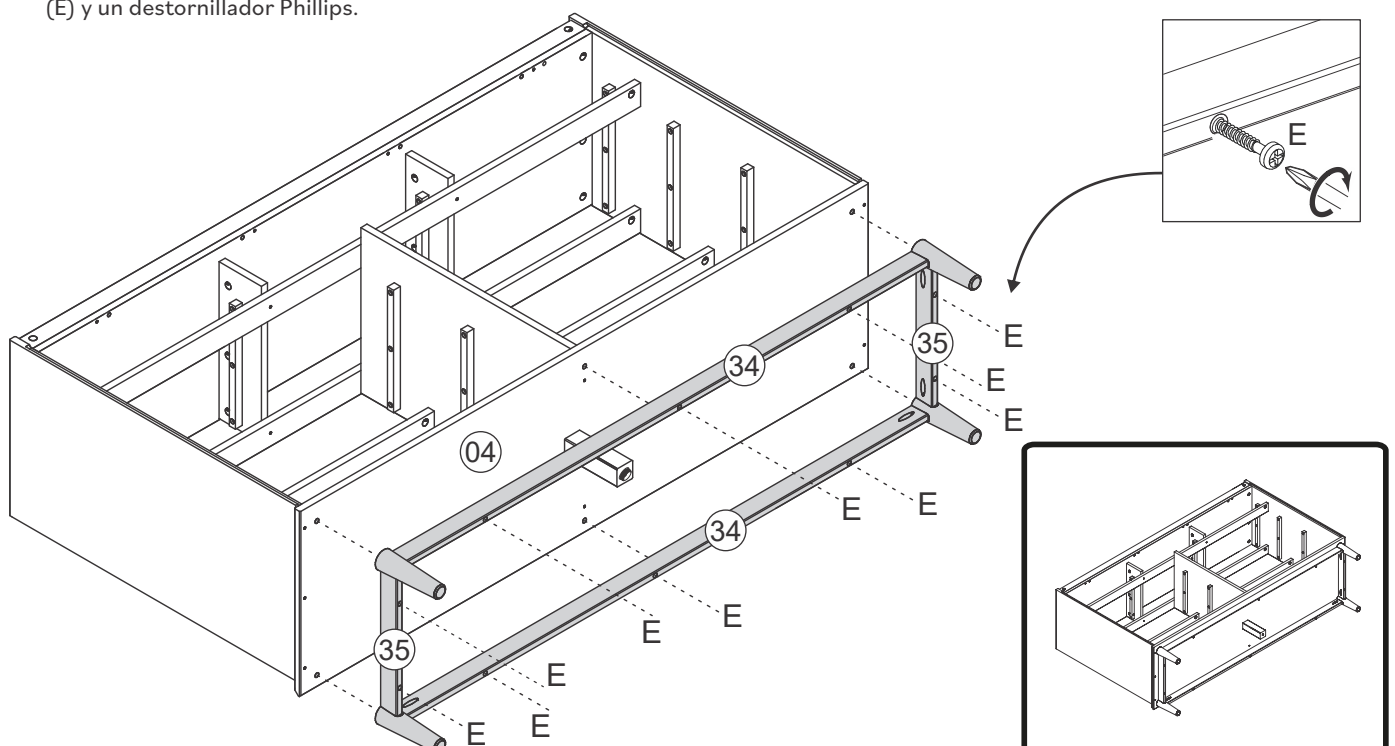

# Étape / Paso 18

(FR)

Fixez le Panneau Arrière Inférieur (21) au Panneau Gauche (02) et au Panneau Droit (03) avec la Vis (D) et un tournevis Phillips. Fixez également à le Panneau Central (16) avec la Vis (I) et un tournevis Phillips.

(ES)

Conecte el Panel Trasero Inferior (21) al Panel Izquierdo (02) y al Panel Derecho (03) con un Tornillo (D) y un destornillador Phillips. También fije el Panel Central (16) con el Tornillo (I) y un destornillador Phillips.

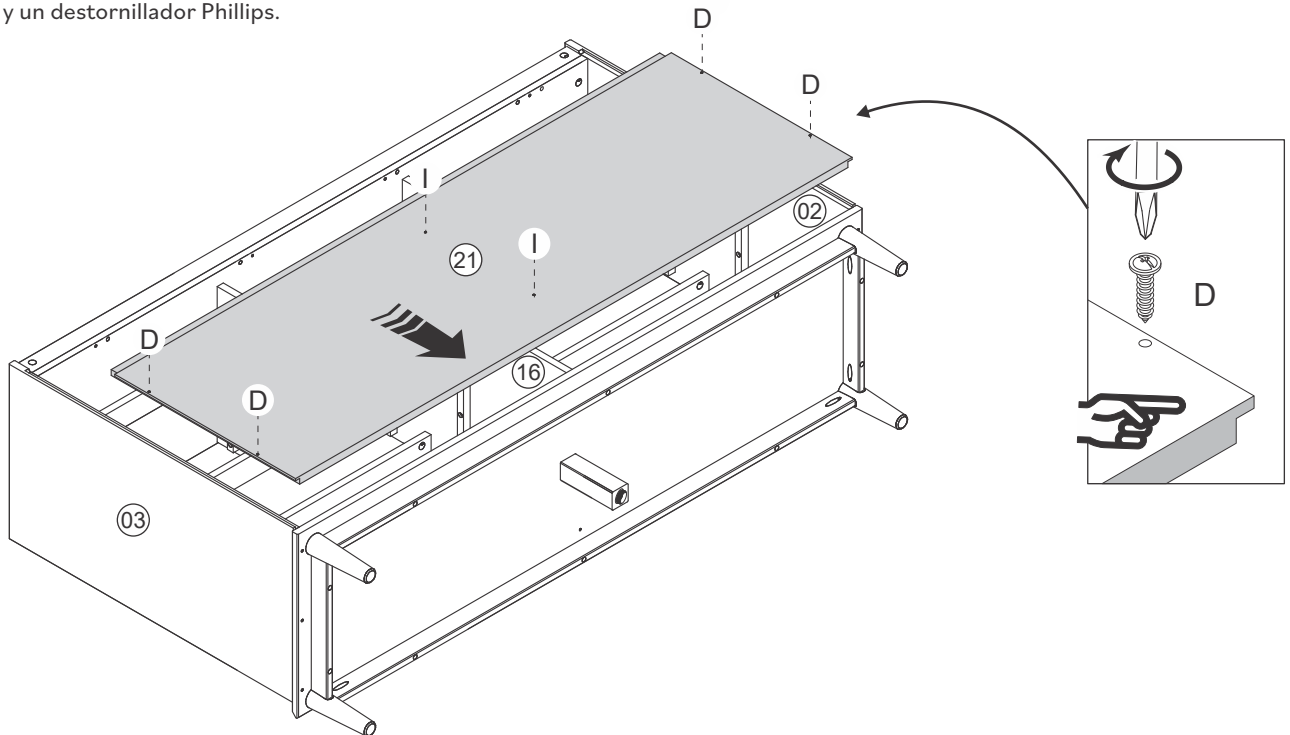
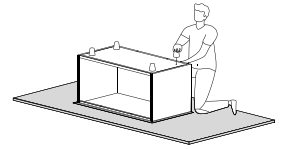

# Étape / Paso 19

(FR)

Fixez le Panneau Arrière (20) à l'aide de Clous (M) et d'un marteau.

(ES)

Asegure el Panel Trasero (20) usando Clavos (M) y un martillo

Nome e endereço do fabricante e data de produção

Nome e endereço do fabricante e data de produção

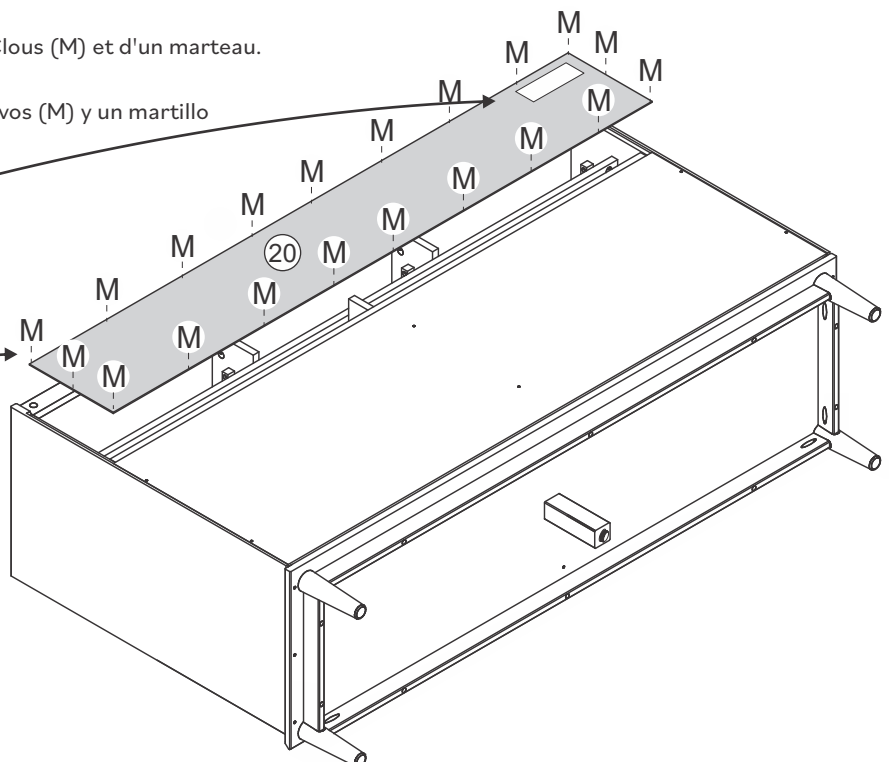
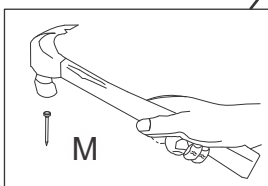

# Étape / Paso 20

(FR)

Fixez le Côté Gauche du Tiroir (05) et le Côté Droit du Tiroir (06) à l'Façade du Tiroir (08) à l'aide de Boitier de Assemblage (K) et d'un tournevis Phillips

(ES)

Asegure el Lado Izquierdo del Cajón (05) y el Lado Derecho del Cajón (06) al Frente del Cajón (08) usando Traba del Conector (K) y un destornillador Phillips.

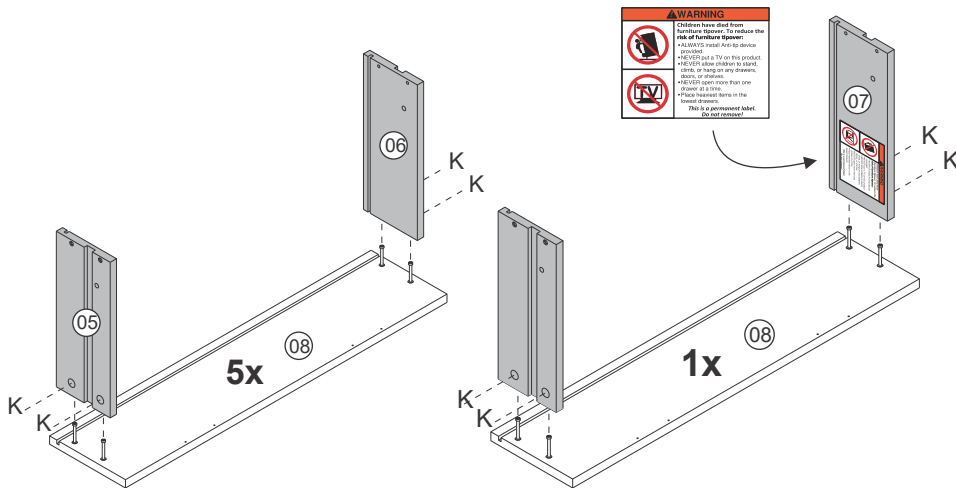
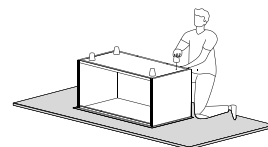

# Étape / Paso 21

(FR)

Faites glisser le Fond du Tiroir (09) sur les rainures du Côté Gauche du Tiroir (05) et du Côté Droit du Tiroir (06) en les plaçant dans la Façade du Tiroir (8). Fixez l'Arrière du Tiroir (10) avec la Vis (I) et un tournevis Phillips. Un tiroir utilisera le Côté Droit du Tiroir (Avertissement) (07), il devrait s'agir du tiroir supérieur droit.

(ES)

Deslice la Fondo del Cajón (09) en las ranuras del Lado Izquierdo del Cajón (05) y del Lado Derecho del Cajón (06), encajando en el Frente del Cajón (8). Asegure el Trasero del Cajón (10) con el Tornillo (I) y un destornillador Phillips. Un cajón usará el Lado Derecho del Cajón (Advertencia)(07), este debería ser el cajón superior derecho.

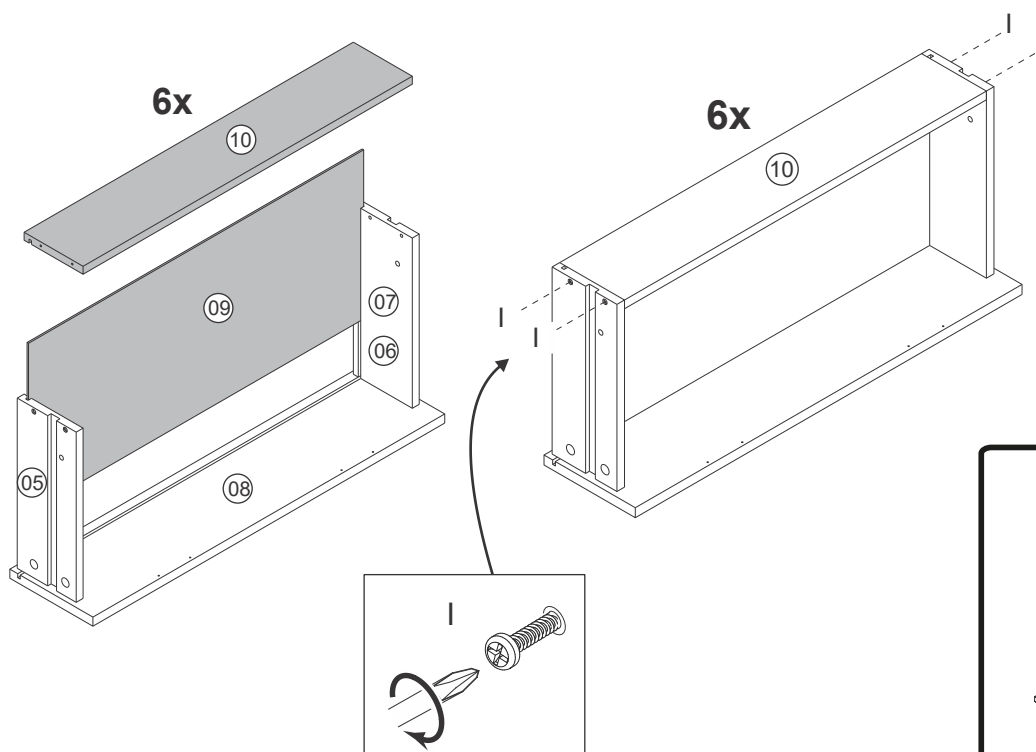

# Étape / Paso 22

(FR)

Fixez la Poignée (Q) à l'aide de la Vis (C) et d'un tournevis Phillips dans les trous prépercés sur la Façade du Tiroir (08).

(ES)

Asegure la Manija (Q) usando el Tornillo (C) y un destornillador Phillips en los agujeros previamente perforados en el Frente del Cajón (08).

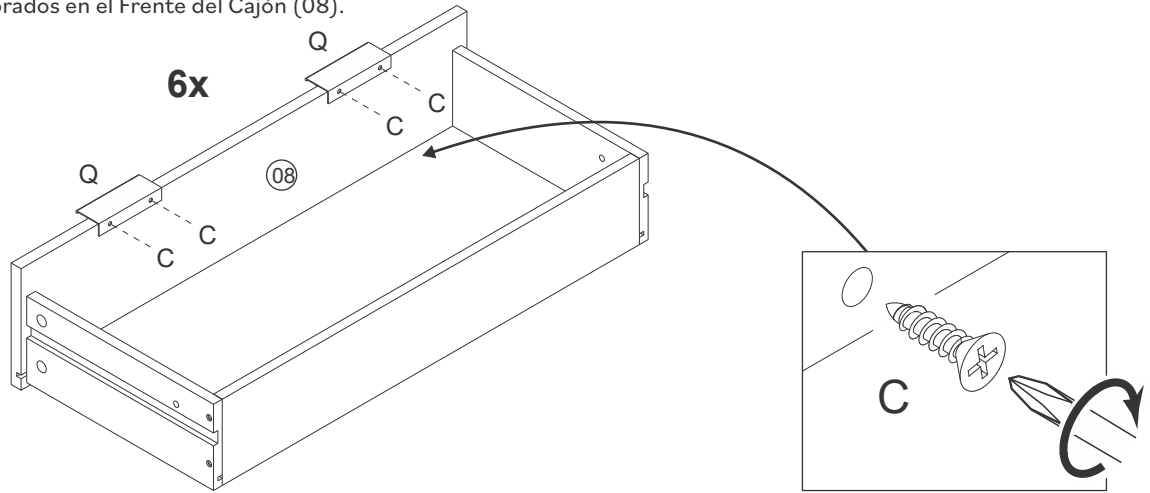
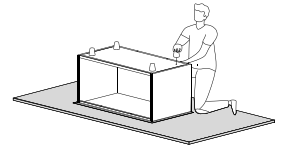

# Étape / Paso 23

(FR)

Assemblez les petits tiroirs comme vous l'avez fait pour les grands, utilisez le Petit Côté Gauche du Tiroir (46), le Petit Côté Droit du Tiroir (47), la Petite Façade du Tiroir (23), Petit Fond du Tiroir (48), Petit Arrière du Tiroir (45) et Vis (I) avec un tournevis Phillips.

(ES)

Ensamble los cajones pequeños como lo hizo con los grandes, use el Lado Izquierdo del Cajón Pequeño (46), el Lado Derecho del Cajón Pequeño (47), el Frente del Cajón Pequeño (23), la Parte Inferior del Cajón Pequeño (48), la Trasero del Cajón Pequeño (45) y el Tornillo (I) con un destornillador Phillips.

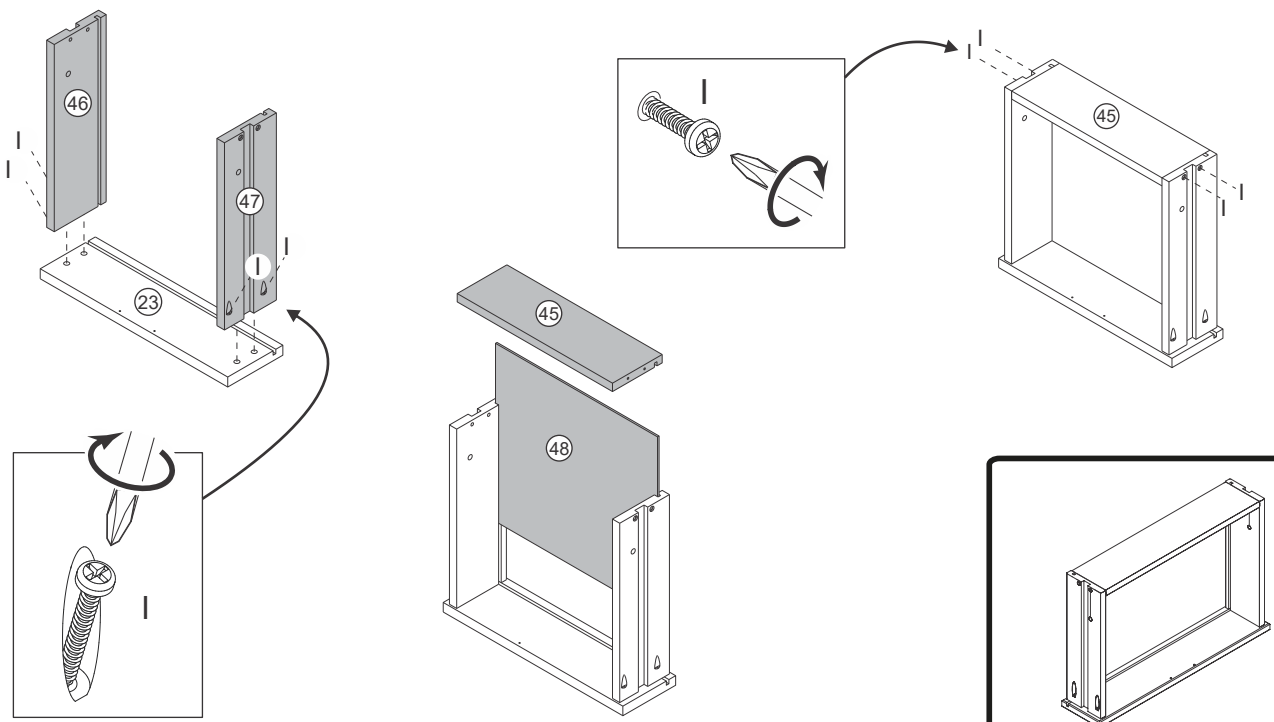

# Étape / Paso 24

(FR)

Fixez la Poignée (Q) avec la Vis (C) et un tournevis Phillips dans les trous pré-perçés sur la Façade du Petit Tiroir (23).

(ES)

Asegure la Manija (Q) con un Tornillo (C) y un destornillador Phillips en los agujeros pretaladrados en el Frente del Cajón Pequeño (23)

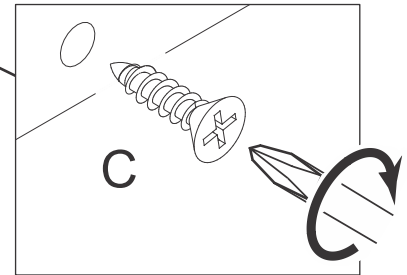
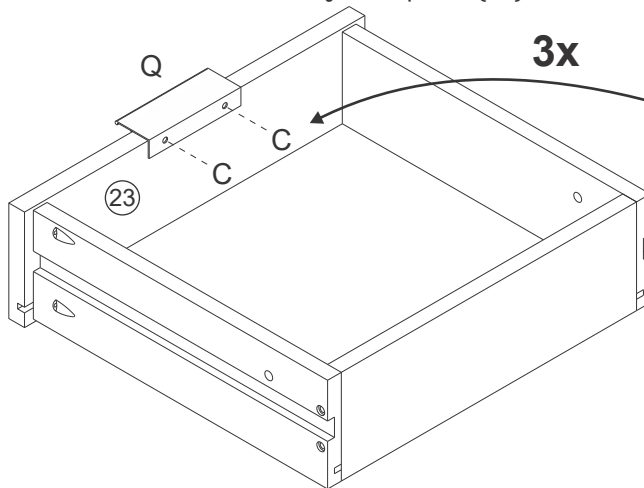
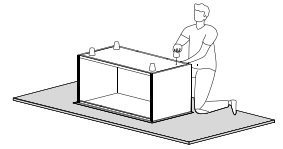

# Étape / Paso 25

(FR)

Insérez la Cheville (A) dans le Glissière (17), ce sera la butée du tiroir.

(ES)

Inserte la Espiga (A) en la Corredera (17), este será el tope del cajón.

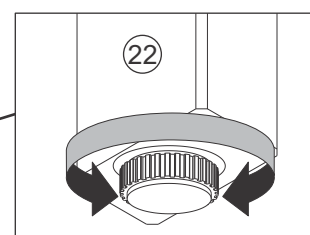
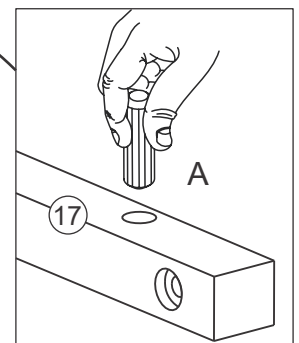
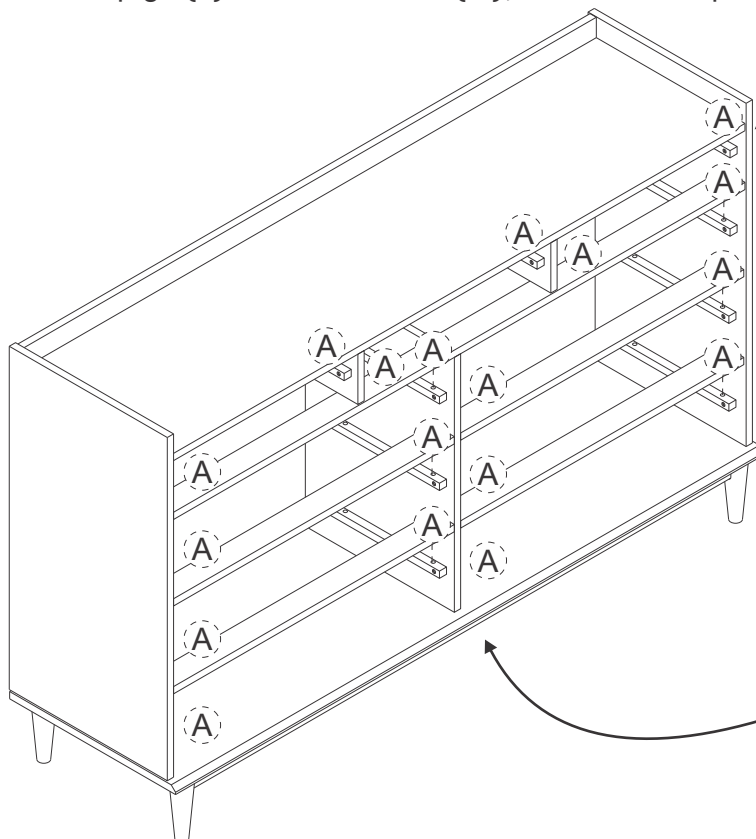

# Étape / Paso 26

(FR)

Insérez la Cheville (B) à l'intérieur de tous les tiroirs, avec le tiroir à l'intérieur du meuble, après avoir passé la cheville en bois qui se trouve dans la glissière du tiroir. La cheville n'est pas alignée avec le côté du tiroir, elle se trouve un peu à l'intérieur du tiroir pour vous aider lorsque vous devez retirer la cheville de verrouillage pour démonter le tiroir.

(ES)

Inserte la Espiga (B) en el interior de todos los cajones, con el cajón dentro de la unidad, después de haber pasado la Espiga que se encuentra en la corredera del cajón. La espiga no está alineada con el costado del cajón, está un poco dentro del cajón para ayudar cuando necesite quitar la espiga de bloqueo para desmontar el cajón.

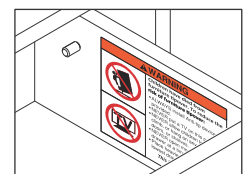
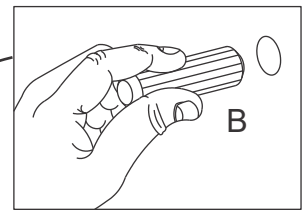
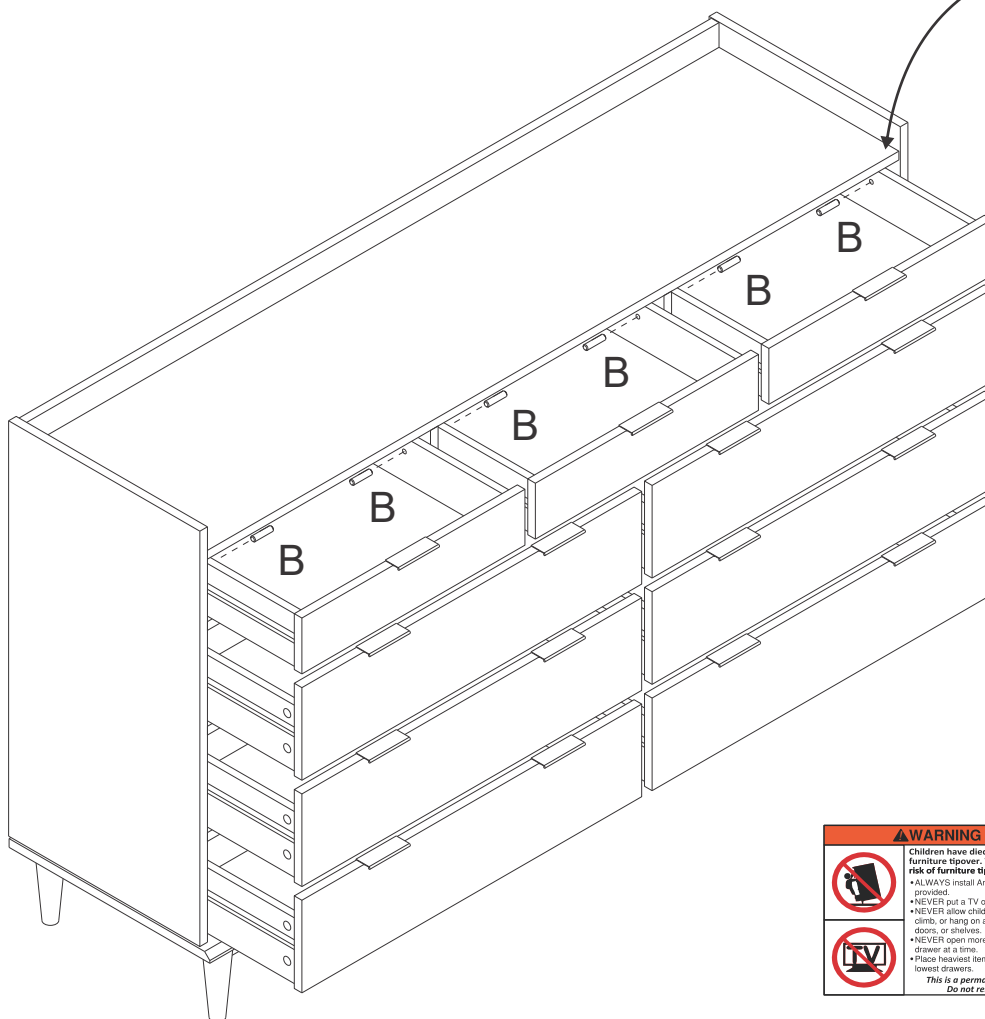
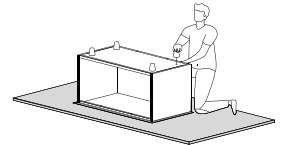

# Étape / Paso 27

(FR)

Enfin, fixons la commode au mur !

Fixez l'rubánl (P) à la commode à l'aide de la rondelle (O) et d'une vis (D).

(ES)

¡Por último, fijemos la cómoda a la pared!

Fije la cinta (P) a la cómoda usando la arandela (O) y un tornillo (D).

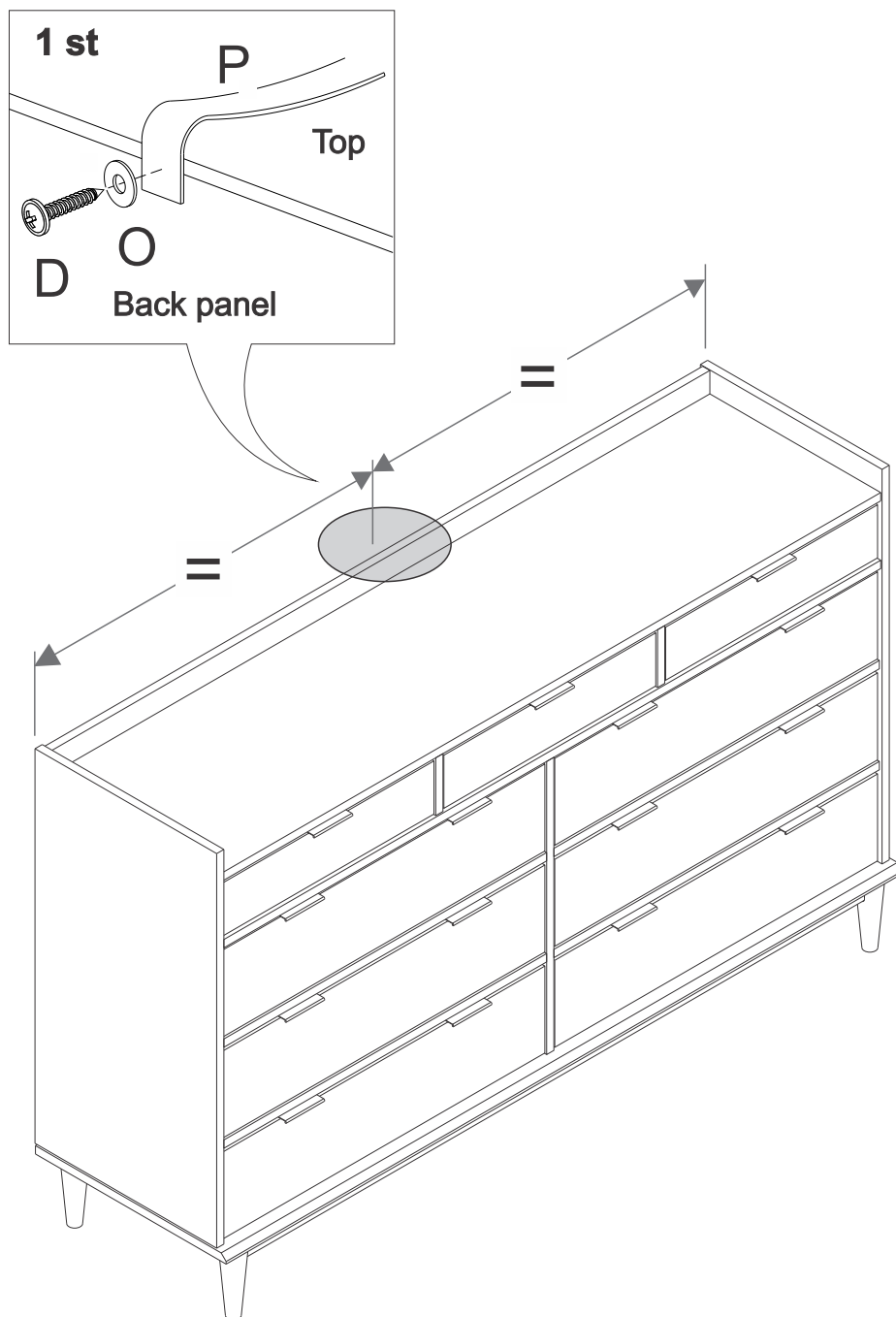



# Étape / Paso 28

(FR)

Insérez le Douille (J) dans le mur. Fixez ensuite l'rubán (P) au mur à l'aide d'une rondelle (O) et d'une vis (I).

(ES)

Inserte el Casquillo (J) en la pared. Luego fije el anclaje de pared (P) a la pared usando una arandela (O) y un tornillo (I).

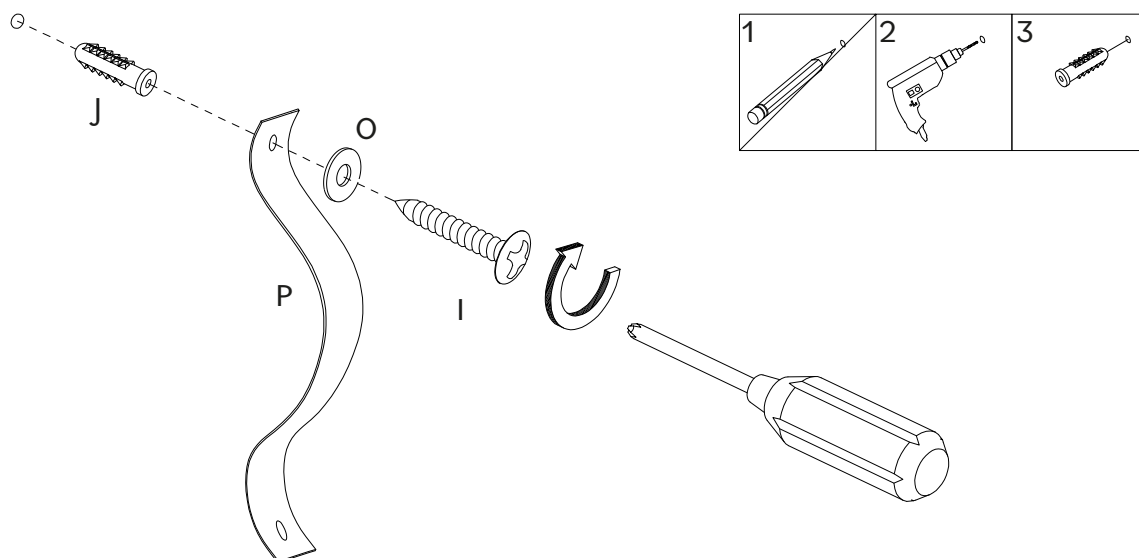

## AVERTISSEMENT

Des blessures graves, voire mortelles, peuvent survenir en cas de renversement de meubles. Pour éviter que le meuble ne bascule, nous recommandons de le fixer définitivement au mur. L'ancrage mural et les autres composants sont inclus dans ce produit. Assure-toi que les composants sont adaptés à tes murs avant l'installation, car différents matériaux de mur peuvent nécessiter différents types d'ancrages.

Le nom et l'adresse du fabricant responsable des composants anti-bascule ainsi que la date de production se trouvent sur l'étiquette au dos du meuble.

## ADVERTENCIA

Pueden ocurrir lesiones graves o fatales debido a la caída de muebles. Para evitar que os muebles se caigan, recomendamos que se fijen permanentemente a la pared. El anclaje de pared y los herrajes están incluidos en este producto. Asegúrate de que los herrajes sean adecuados para tus paredes antes de la instalación, ya que diferentes materiales de pared pueden requerir diferentes tipos de anclajes.

El nombre y la dirección del fabricante responsable de los herrajes antivuelco y la fecha de producción se pueden encontrar en la etiqueta de la parte trasera de los muebles.

**Vous avez réussi ! Profitez de votre nouvelle commode !  
Lo has conseguido! Disfruta de tu nueva cómoda !**

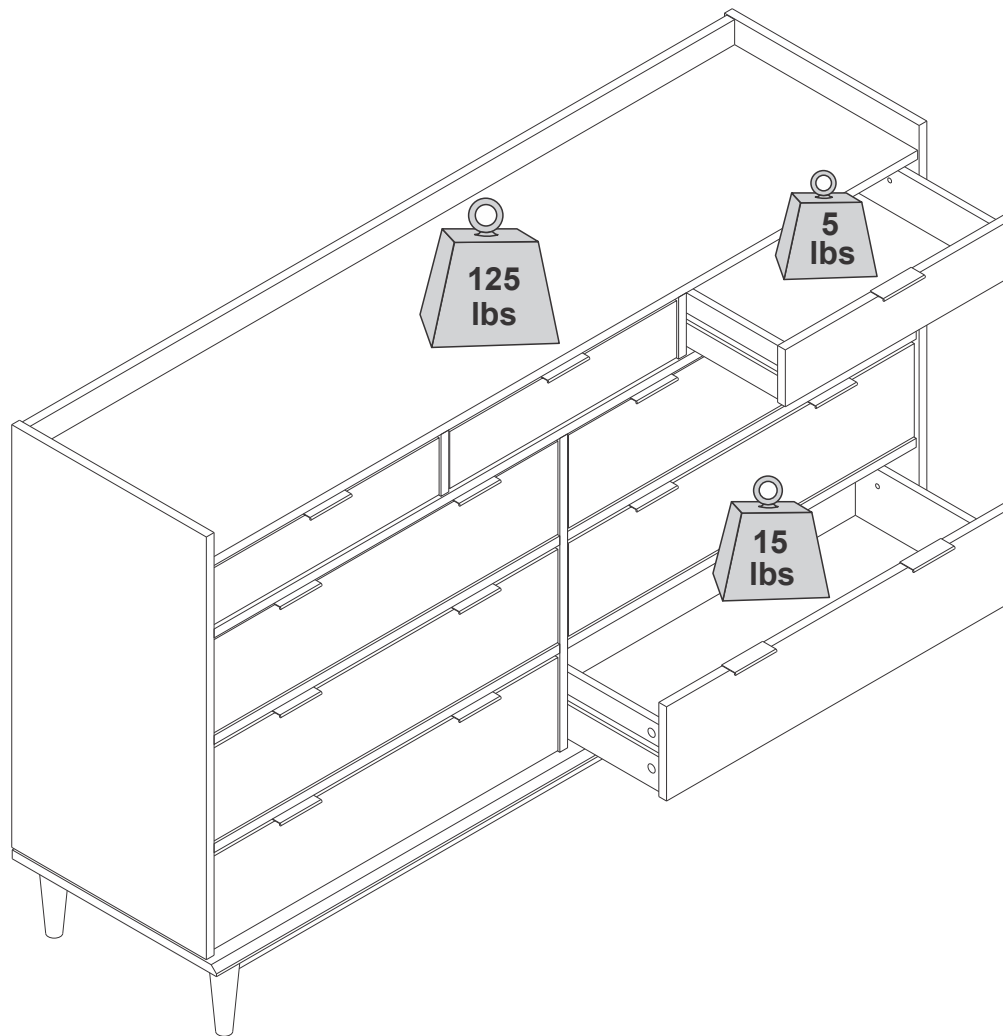

**Félicitations pour votre nouveau meuble!  
Nous serions ravis d'en entendre parler et de le voir.  
Laissez-nous un commentaire ou postez une photo  
avec le mot-clé #mywalkerredisonhome**

**Enhorabuena por su nuevo mueble!  
Nos encantaría conocerlo y verlo.  
Por favor, déjenos un comentario o  
publique una foto con #mywalkerredisonhome**

## Assembler des meubles peut parfois être compliqué.

Notre équipe de service client, située dans l'Utah, est là pour obtenir des informations sur les produits, aider pour l'assemblage d'un produit ou pour tout autre problème de support client.

Appelle-nous **801-433-3008**

Envoie-nous les e-mails à **[service@walkeredison.com](mailto:service@walkeredison.com)**

Visite notre site accueil au client à

**[walkeredison.com/pages/customer-service](https://walkeredison.com/pages/customer-service)**

Nous sommes disponibles pour t'aider du Lundi au Jeudi de 8 am - 5 pm, Vendredi de 8 am - 15 pm MST.

Pour plus de détails sur les vidéos d'assemblage, les instructions d'assemblage, les pièces de rechange et le service client.

**NUMÉRISER ICI.**



Pour le nettoyage, n'utilise jamais d'abrasifs, utilise un chiffon doux et de l'eau avec du savon neutre pour nettoyer les meubles

## Assembler des meubles peut parfois être compliqué.

Notre équipe de service client, située dans l'Utah, est là pour obtenir des informations sur les produits, aider pour l'assemblage d'un produit ou pour tout autre problème de support client.

Appelle-nous **801-433-3008**

Envoie-nous les e-mails à **[service@walkeredison.com](mailto:service@walkeredison.com)**

Visite notre site accueil au client à

**[walkeredison.com/pages/customer-service](https://walkeredison.com/pages/customer-service)**

Nous sommes disponibles pour t'aider du Lundi au Jeudi de 8 am - 5 pm, Vendredi de 8 am - 3 pm MST.

Pour plus de détails sur les vidéos d'assemblage, les instructions d'assemblage, les pièces de rechange et le service client.

**NUMÉRISER ICI.**



Pour le nettoyage, n'utilise jamais d'abrasifs, utilise un chiffon doux et de l'eau avec du savon neutre pour nettoyer les meubles