

Please go to www.quoizel.com for product cleaning tips. Go to the **Care + Maintenance** selection.

Tools Required: Flathead screwdriver, Phillips screwdriver, Shovel, Electrical tape, Wire cutter, Safety glasses, Wire strippers and proper length wires (not included).

Estimated Assembly Time: 30-45 minutes

Preparation: Identify and inspect all parts before beginning installation. Check package content list and diagrams below to be sure all parts are present. If any parts are missing or damaged, do not attempt to assemble, install, or operate the fixture. Contact customer service for replacement parts.

⚠ Warnings and Cautions

Turn off electricity at circuit breaker or main fuse box before installation. Consult a licensed electrician if in doubt.

These instructions are provided for your safety. It is very important you read them completely before installing the fixture. We strongly recommend that a licensed, professional electrician perform the installation.

Package Contents

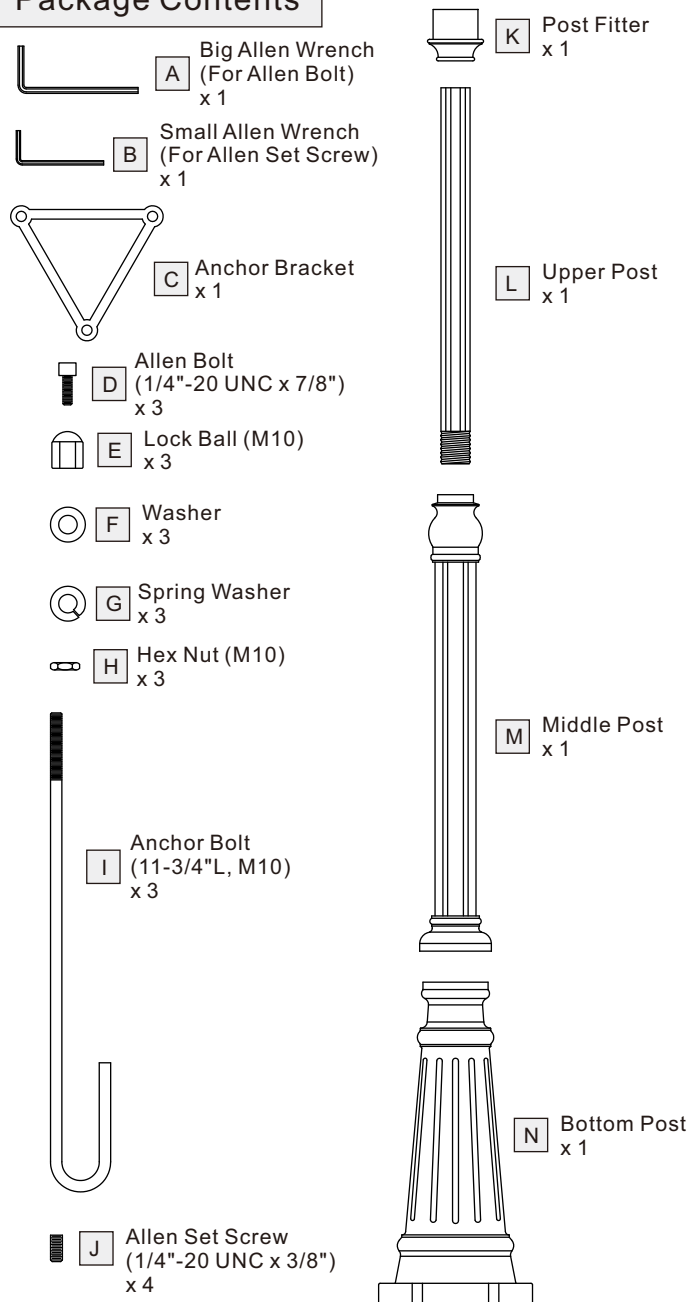

STEP 1 – Assemble Anchor Bolts to the Anchor Bracket

- A. Remove all Spring Washers (G), Hex Nuts (H) and Lock Balls (E) from the Anchor Bolts (I).
- B. Screw the threaded end of each Anchor Bolt (I) in the Mounting Bracket (C) making sure to that the Anchor Bolt (I) is 1.75" to 2" extended from the bottom of the Bracket (C).
- C. Place a Spring Washer (G) over the Anchor Bolt (I) and then thread the Hex Nut (H) onto each Anchor bolt (I). Securing the Bracket (C) in place maintaining the 1.75"-2" length of the Anchor Bolt (I).

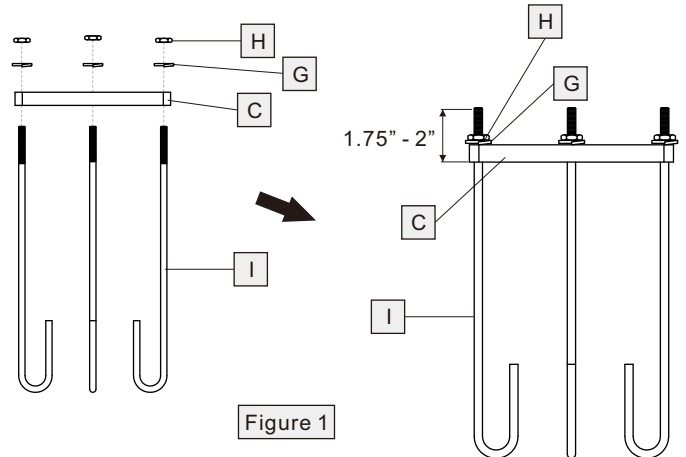

Figure 1

STEP 2 – Install Anchor Bolts in the ground

- A. At the desired location for the post a hole with a minimum depth of 15" is required for proper installation of the post mount. Please check with local building codes as local codes will always supersede these instructions.
- B. Use cement to secure the Anchor Bolts (I) into the ground making sure that the Bracket (C) is flush on top of the cement and level Anchor at the desired grade with the ground. This is the base for the Post Mount.

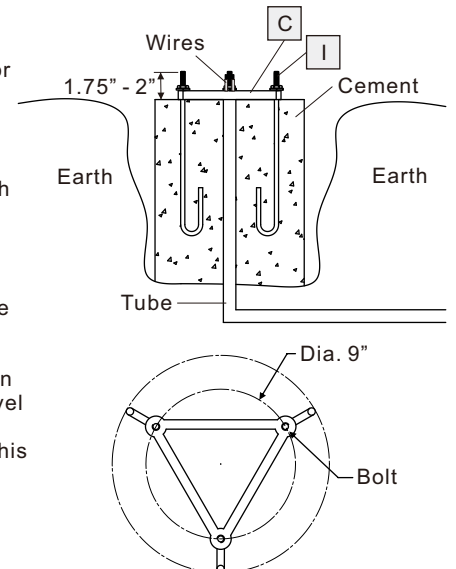

Figure 2

STEP 3 – Assemble Post Fitter and Posts together

- A. Place the Post Fitter (K) on the Upper Post (L) end without the threads. Secure the Post Fitter (K) with (2) Allen Set Screw (J) using the Small Allen Wrench (B) provided.
- B. Thread the Upper Post (L) assembly onto the Middle Post (M) until secure. Secure the Upper Post (L) assembly to the Middle post (M) using (2) Allen Set Screw (J) and the Small Allen Wrench (B) provided.
- C. Place the Middle Post (M) assembly onto the Bottom post (N) lining up the mounting holes in the Middle Post (M) assembly with the Bottom Post (N). Secure the Middle Post (M) assembly to the Bottom Post (N) using (2) Allen Bolt (D) and the provide Big Allen Wrench (A). Tighten until secure.

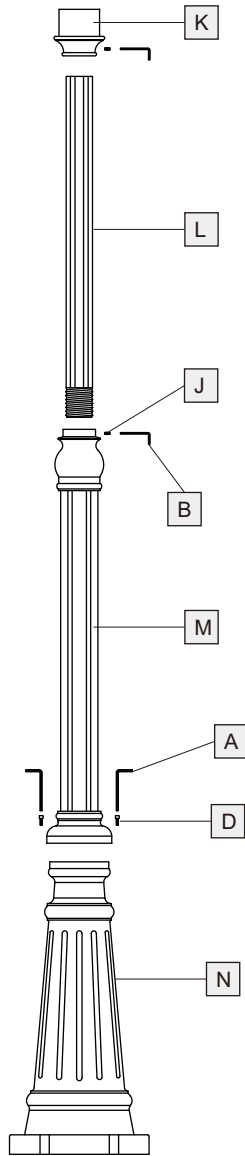

Figure 3

STEP 4 - Wire Connections

- A. Use standard wire connectors (not included) to make all wire connections. Twist connectors until wires are tightly joined together. Wrap each connection with approved electrical tape and carefully stuff all the connected wires into the Outlet Box.

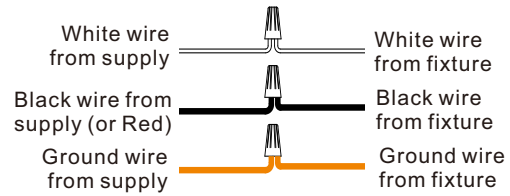

Figure 4

STEP 5 - Install Post Mount Assembly to Anchor Bolts

- A. Place the Post Mount assembly onto the Anchor Bolts (I). Place a Washer (F) over each Anchor Bolt (I) and secure each Anchor Bolt (I) with the Lock Ball (E) and tighten until secure.

Your installation is completed now. Restore electricity. Retain this sheet for future reference.

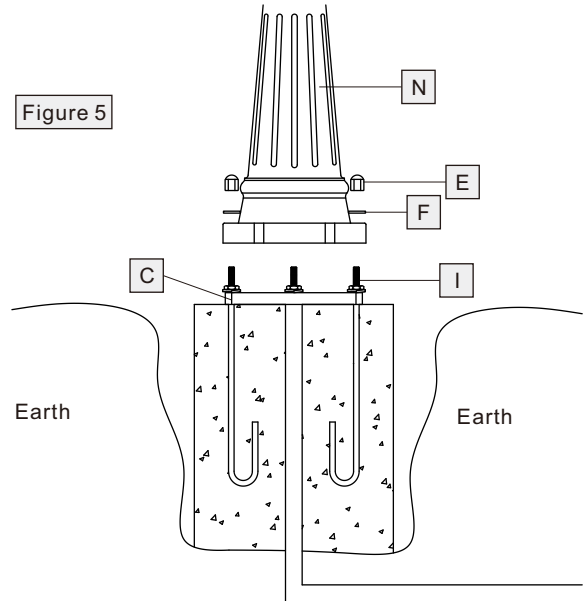

Figure 5

INSTALL POST LIGHTING TO POST MOUNT

Tools Required: marking pen, 5/32" drill bit, center punch, hammer, drill, #10 self-tapping screw, and wrench.

STEP 1 – Mark the Location of the 3 Mounting Holes

- A. Place the light fixture onto the post fitter and mark the location of the 3 mounting holes on the fixture fitter onto the post fitter with the marking pen.

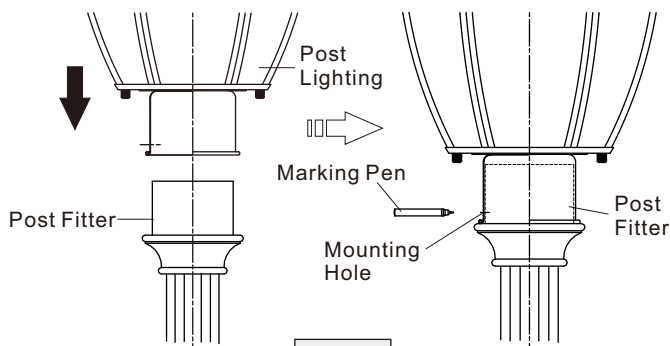

Figure 1

STEP 2 – Marking the Center of Each Mounting Hole

- A. Remove the light fixture. Using the center punch and hammer marking the center of each mounting hole location that is marked with the marking pen.

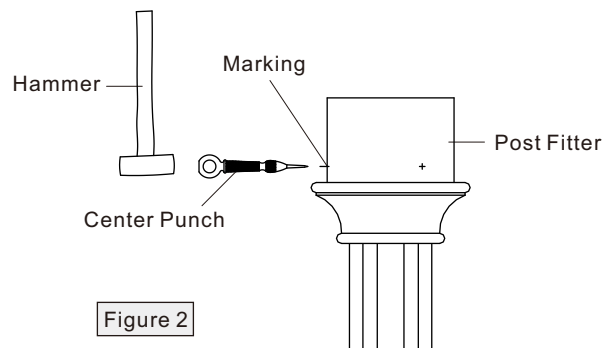
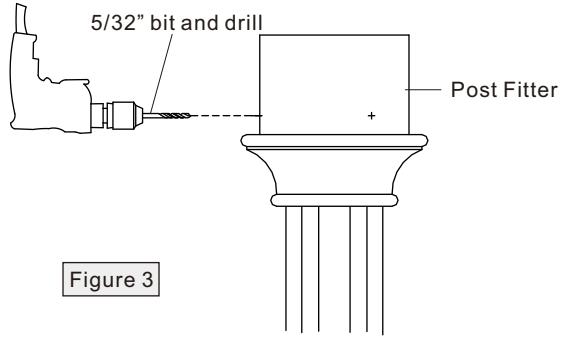

Figure 2

STEP 3 - Drill Holes

A. Using the 5/32" bit and drill, drill a hole completely through the post fitter at each (3) locations marked in step 2 above.



STEP 4 - Attach the fixture to the Pier Mount

A. Wire the fixture according to the instructions and place the fixture on the post fitter lining up the mounting holes on the fixture fitter with the holes on the post fitter.

B. Use the #10 Self-tapping Screws (not provided) to attach the fixture to the post fitter.

